

4150

TECHNICAL LIBRARY
REFERENCE COPY



SOCIETY OF AUTOMOTIVE ENGINEERS, INC.
485 Lexington Avenue, New York 17, N. Y.

The Universal Engineer Tractor: A High Speed Tracked Vehicle with Low Speed, High Drawbar

DISTRIBUTION STATEMENT A
Approved for Public Release
Distribution Unlimited

Performance

Rodney D. Hardy and Richard P. White
U. S. Army Engineer Research and Development Laboratories

SOCIETY OF AUTOMOTIVE ENGINEERS

Automotive Engineering Congress
Detroit, Mich.
Jan. 14-18, 1963

616C

Reproduced From
Best Available Copy

20011017 116

AN 35894

The Universal Engineer Tractor: A High Speed Tracked Vehicle with Low Speed, High Drawbar Performance

Rodney D. Hardy and Richard P. White

U. S. Army Engineer Research and Development Laboratories

AN UNUSUAL MILITARY TRACKED vehicle is under development by the U. S. Army Mobility Command. Called the Universal Engineer Tractor (UET), it is a lightweight, multipurpose construction machine, which is capable of transporting the combat engineer squad and its equipment. Its versatile configuration makes it suitable for use as a bulldozer, scraper, rough grader, prime mover, dump truck, cargo carrier, and armor-protected personnel carrier. It is capable of high speed convoy and cross-country operations as a transport vehicle, or of producing a high drawbar pull as a low speed tractor. The UET is light enough to float in the water and be air-dropped by parachute; yet it is designed and powered so it can load itself with earth or other material to provide the same work performance as a vehicle nearly twice its 28,000 lb weight. For example, it can be used to move men, materials, and equipment to a worksite, unload itself and perform a variety of construction tasks to complete a mission normally requiring several different single-purpose machines. It can then carry the men and equipment back to their unit, eliminating the need for any additional transportation.

To achieve the vehicle characteristics necessary for multipurpose use, without acquiring a complex design, required the introduction of several concepts new to construction vehicles. Some of these were the ballastable tractor concept, the hydropneumatic suspension, a high speed - high drawbar track, special broad range transmission packages, and the

use of lightweight materials. Development of these items has produced a practical and versatile vehicle concept. This paper describes the requirements, background, operations, and components of the UET.

REQUIREMENT

In the past, U. S. Army construction operations have been similar to those of civilian construction. Consequently, for many years engineer troops have relied on off-the-shelf modified commercial items to meet their construction equipment requirements. These items are usually procured on a competitive basis by a performance-type specification which, for a motorized scraper, for example, might state the maximum weight, the scraper bowl capacity, a minimum fuel capacity, and similar items. The manufacturer who can meet the requirements at the lowest price usually receives the contract. Consequently, the Army has acquired a tremendous variety of makes and models of equipment, and the correspondingly tremendous maintenance and supply problem of providing adequate spare parts support for them.

The logistical problem is further complicated by the fact that in order to fulfill their mission, even small tactical engineer units require several different items of equipment, for which spare parts support must be readily available. The use of multipurpose equipment would minimize this support requirement.

ABSTRACT

The U. S. Army is presently developing an unusual tracked vehicle--the Universal Engineer Tractor. It is suitable for use as a bulldozer, scraper, rough grader, prime mover, dump truck, cargo carrier, and armor-protected personnel carrier. Its design features a hydropneumatic suspension system, a

high speed-high drawbar track, a special broad range transmission system, the use of lightweight materials, a front scraper bowl with positive type ejection, and a flat track suspension with rear drive sprockets. This paper describes the requirement, background, operations, and components of the Universal Engineer Tractor.

Advancements in weapons and tactical vehicles by other countries has required drastic changes in our tactical operations. Engineer equipment for the future must have greatly improved mobility, provide greater work production, and be capable of aerial delivery. Contrary to these requirements, most present construction equipment is single purpose, too bulky, excessively heavy, and has too low a convoy speed for use in future military operations.

In order to provide the required construction capability and improved mobility with a minimum of supply and maintenance problems, the logical approach appeared to be the development of military-special construction equipment which would be air-droppable and suitable for multipurpose use. This would reduce the total number of items of equipment required by tactical engineer units and minimize the spare parts support through some degree of standardization.

BACKGROUND

In 1949, the U. S. Army began work on the development of a family of military-special air-transportable construction equipment to be used in assault type operations. This equipment, which was basically of modified commercial design, was not an adequate solution since it neither produced the required high work output nor simplified the logistical problem enough. The main limitation, as far as the work capability was concerned, was that the equipment weight at that time could not exceed 16,000 lb due to the air-drop requirement. At this time, the ballastable tractor concept was originated.

The principle of the ballastable concept is that the heavier a piece of equipment is, the greater is its work capability. This is true since traction with the ground limits the maximum work capability of this type of vehicle, and the traction available for a particular situation is directly proportional to vehicle weight. Consequently, if an air-droppable tractor could be loaded or ballasted to twice its weight once it was on the ground, the additional weight would double its work capacity if adequate power was provided.

This thinking was followed by tests on a LeTourneau four-wheel electric drive scraper (Fig. 1), and later on a rubber-tired tractor built by Fairchild and known as the Transair Tractor (Fig. 2). The Transair Tractor was ballasted with water and earth, most of which had to be manually loaded and unloaded. Testing, which continued through 1956, showed that only a very common material, such as earth should be used for ballast, and that the equipment should be able to self-load and unload the ballast in a minimum of time.

These tests were followed by drawing up requirements for a rubber-tired ballastable multipurpose tractor (Fig. 3), commonly known as the BAT. When bids were requested for design and fabrication of a prototype BAT, International Harvester Co. submitted a counterproposal for a crawler version capable of accomplishing the same tasks. This resulted in the award of a contract in 1958 to IHC, for the design and fabrication of a prototype vehicle (Fig. 4), which was called

the ABC Tractor (All-purpose Ballastable Crawler). As the concept of operation for this vehicle became better known, it gained enthusiastic acceptance. Consequently, it was decided to pursue a dual concept to assure that the best possible design approach was being taken. In 1960, a contract was awarded to Caterpillar Tractor Co. for the design and fabrication of a second concept of the multipurpose ballastable crawler tractor. This concept differed mainly in that

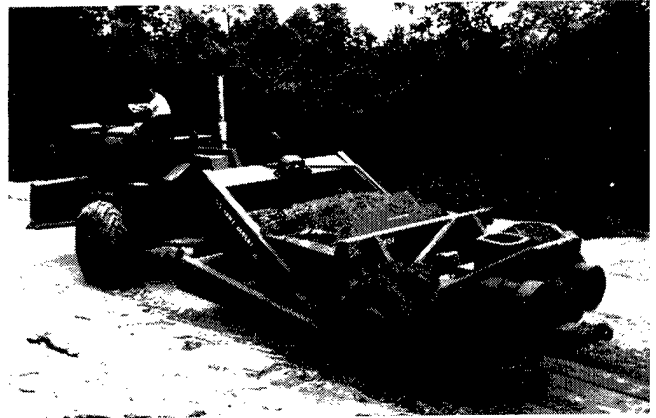

Fig. 1 - Four wheel electric drive scraper

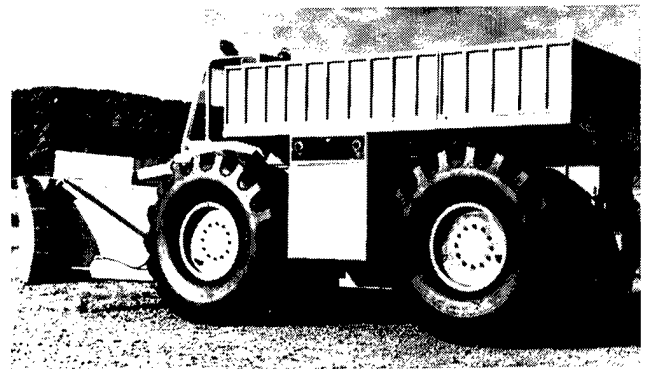

Fig. 2 - Transair tractor

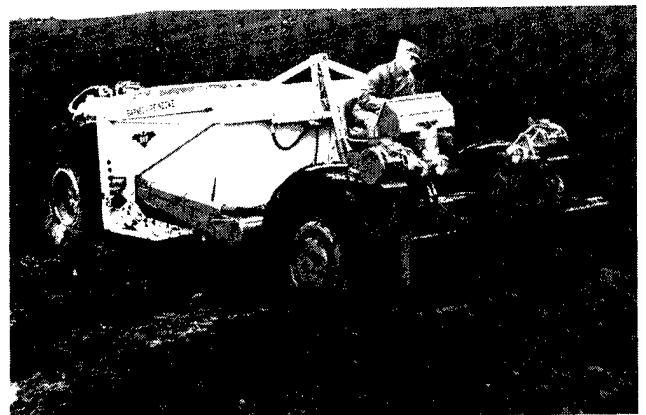

Fig. 3 - BAT, prototype ballastable all-purpose tractor

it used more conventional components and earthmoving techniques to accomplish the same tasks as the first concept.

In May 1960, the first prototype vehicle was completed by IHC. It went through two years of engineering design tests, during which the unique design features of the tractor were put through rigid tests and the ballastable concept was evaluated. The prototype vehicle was tested for 565 hr. Although a great amount of downtime was encountered due to component reliability, these tests proved that the principles were sound and the concept was feasible.

Concurrent with testing of the prototype, design was progressing on two second generation tractors at IHC. Tests of the ABC provided the information on changes made on the second generation vehicles. They were to include a hydrostatic-type transmission in place of the transmission-steer unit used in the prototype. This type of transmission was selected because the Army felt that it would best meet this vehicle's unusual transmission and steering requirements. The hydrostatic transmission was designed and built specifically for this vehicle, under a U. S. Army contract, by the Sundstrand Corp.

Originally, the vehicle was envisioned as being strictly an earthmoving machine for airborne units. During the course of development, its concept of application has undergone many changes. In April 1961, since its operational concept had now been expanded to include primary transportation for the engineer squad, the ultimate users of the vehicle decided that it should provide some form of armor protection. This requirement was given priority over the air-droppable characteristic but did not eliminate the need for it. Both concepts were subsequently modified to provide protection for the operator and personnel.

One of the second generation tractors being built by IHC was already being fabricated when the armor requirement arose. Since the need for an air-droppable version still existed, in order to minimize delay in the development program, it was completed as originally designed, without any armor. This version, called the Universal Engineer Tractor-Model E1 (UET-E1), was completed in December 1961 (Fig. 5) and incorporated the previously mentioned hydrostatic transmission. It weighed 22,500 lb, but since all components other than the hulls were interchangeable between the two vehicles, it was deadweighted during tests to simulate

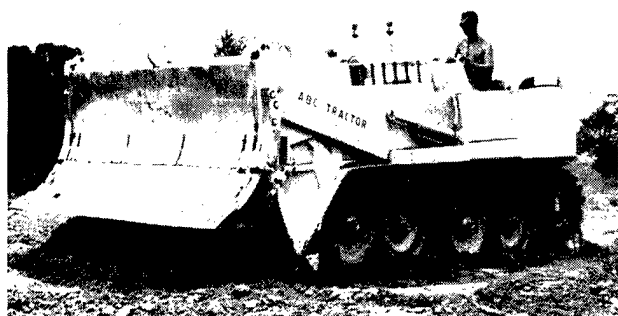

Fig. 4 - ABC, prototype of Universal Engineer Tractor

the weight of the armored version. Due to the inflexible development schedule for the vehicle and relative state of development of the hydrostatic transmission, in the armored version it was decided to return to the transmission system used in the prototype vehicle.

Fabrication of both armored versions was completed in July 1962. The armored version built by IHC (Fig. 6) was called the Universal Engineer Tractor-Model E2 (UET-E2), and the other armored concept, built by Caterpillar (Fig. 7), was called the Universal Engineer Tractor-Model A (UET-A). The main physical difference between the two armored versions was the UET-A's front mounted multiple segment bucket, used for dozing and scraping operations. After preliminary break-in tests were conducted, the vehicles were

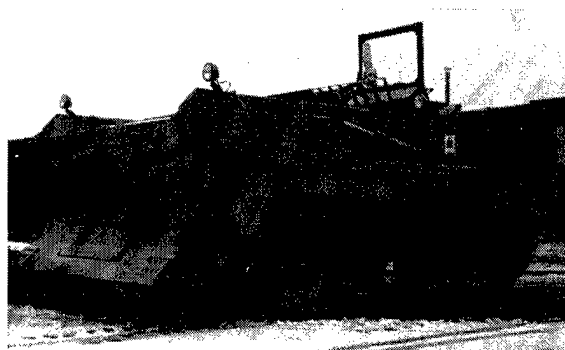

Fig. 5 - UET-E1, second generation UET

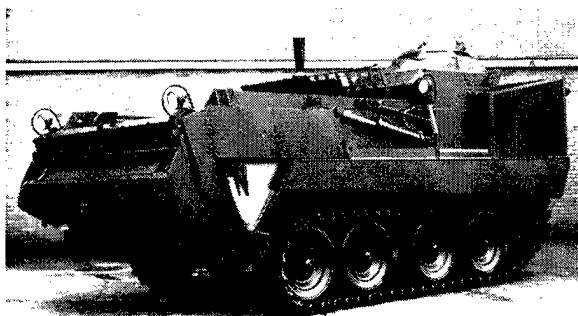

Fig. 6 - UET-E2, armored version of UET

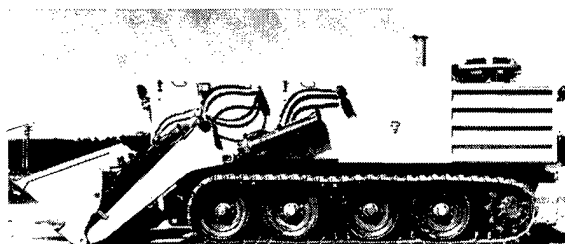

Fig. 7 - UET-A, dual concept of armored UET

sent to the Engineer Proving Ground at Fort Belvoir. All three models are presently undergoing expedited endurance tests to determine the best design from the standpoint of reliability and configuration.

OPERATIONS

Dozing - The UET-E1 and E2 bulldoze (Fig. 8) by raising and lowering the entire front end of the tractor with respect to the ground. This is accomplished with the suspension system, which raises and lowers the two front (No. 1 and 2) wheels and allows the tractor to pivot about a point midway between the two rear wheels. To start a dozing cut, the operator raises the front wheels, allowing the dozer blade which is solidly fastened to the hull, to drop down and penetrate the ground. Wheel travel permits the dozer blade to cut a depth of 14 in. The dozer blade is hinged in the middle, and, when not in use, can be folded up to increase the vehicle's angle of approach.

The UET-A dozes in the conventional way by raising and lowering the dozer blade with respect to the hull (Fig. 9). The dozer blade forms the rear section of the multiple segment bucket and is brought into use by raising the clam portion of the bucket. It is controlled by double-acting hydraulic cylinders and has a maximum depth of cut of 8 in.

All models of the UET are able to tilt doze by varying

the height of one side of the tractor with respect to the other (Fig. 10). Tilting is accomplished with the versatile suspension system. This position can be maintained during the dozing cut, which makes this vehicle acceptable for military use as a rough grader.

Another important use of the UET is in land clearing operations. The tilting feature enables the tractor to dig around the base of trees to loosen the earth and roots. The dozer blade can be raised to provide better leverage for tree felling, and then lowered to clear away the trees and brush.

Scraping - Both versions of the UET employ completely different and novel means of loading the bowl or ballast compartment. The UET-A performs the function of a scraper by filling its front mounted bucket, raising it, tilting it backwards, and dumping the contents into the bowl (Fig. 11). Four bucket loads are required to fill the six yard bowl (struck). The ballast is removed by opening the hydraulically actuated front doors and pushing the earth out with a hydraulically powered ejector (Fig. 12). The bucket also enables the tractor to perform bucket loader operations, such as loading trucks and stockpiling.

The E1 and E2 scrape (Fig. 13) by raising and lowering the front of the tractor with respect to the ground, similar to dozing. The scraper cutting edge is mounted behind the dozer blade, on the front edge of the eight yard bowl (struck).

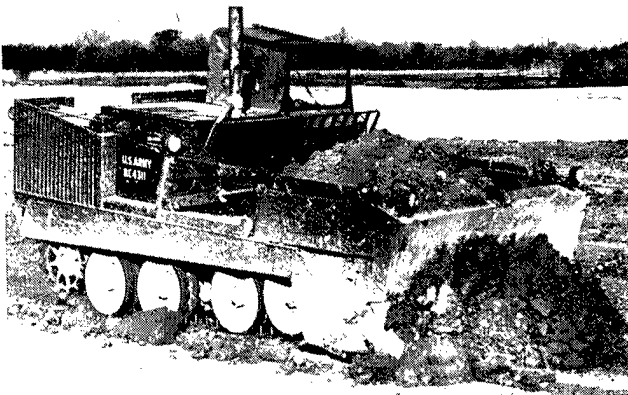

Fig. 8 - Bulldozing, UET-E2



Fig. 10 - Tilt dozing

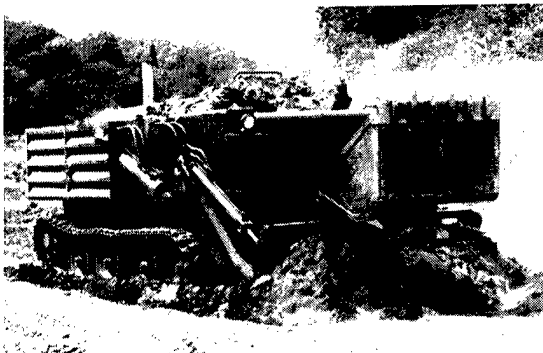

Fig. 9 - Bulldozing, UET-A

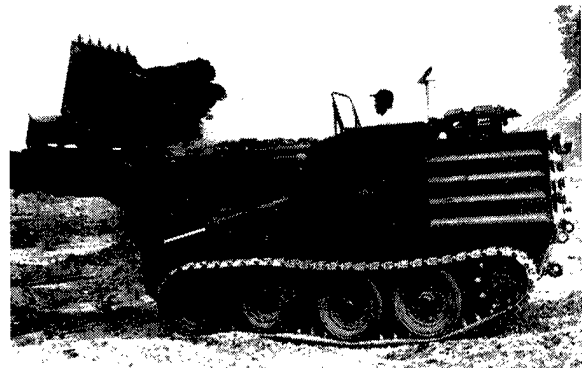

Fig. 11 - Self-loading earth, UET-A

It is brought into use by raising the apron, and lowering the front of the tractor by means of the suspension system until the scraper cutting edge penetrates the ground. The front loading scraper, which can cut to a depth of 8 in., then self-loads earth in the conventional manner. The earth is contained in the bowl by the hydraulically operated apron, and is removed by raising the apron and pushing the earth out with the hydraulic ejector. To increase scraper production, the E1 and E2 can be push loaded by another UET.

All models are able to tilt scrape by varying the height of one side of the tractor with respect to the other. Also, their front-located bowls give them the added advantage of being able to dump over embankments.

Prime Moving - The performance of a prime mover is basically a function of its traction and horsepower. Since the UET is a high speed tracked vehicle with a favorable weight to horsepower ratio, it is able to sustain continuous high speeds and has good gradability for towing loads on highways. In addition, for cross-country operations, it has the



Fig. 12 - Ejecting load

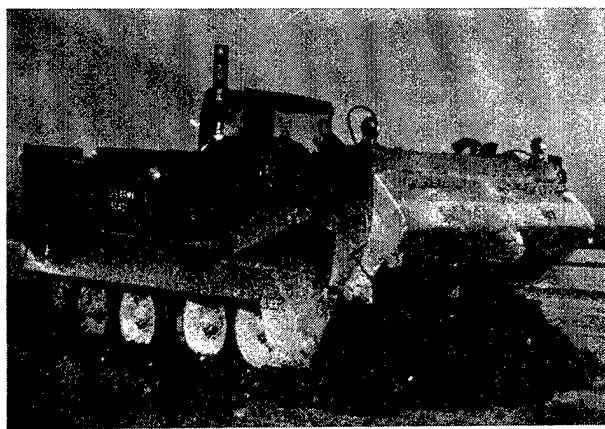

Fig. 13 - Scraping, UET-E2

traction and mobility to pull the same loads, even under adverse conditions. The vehicle is able to traverse 60% longitudinal slopes and 35% side slopes. Its ground pressure ranges from 7 psi for an empty vehicle to 13 psi for a fully ballasted armored tractor. The normal ground clearance of 18 in. can be increased by raising the vehicle with the suspension. Should traction become marginal, the UET can ballast itself as needed to increase its own weight and provide the required traction. The vehicle will provide a draw-bar pull of 20,000-45,000 lb, depending upon the amount of ballast it is carrying. It has an empty weight to horsepower ratio of approximately 100 lb/hp.

Personnel and Cargo Hauling - The same mobility features which make the UET a good prime mover make it a versatile personnel and cargo carrier. It is able to sustain speeds of 30 mph on improved surfaces and travel cross-country at much higher speeds than rubber-tired equipment. Its hydropneumatic suspension provides a smooth stable ride, even over quite rough terrain.

Envisioned as the basic squad vehicle in engineer combat battalions, the UET provides lateral armor protection against small arms fire and fragmentation for troops in the bowl, and all-around protection for the operator. It will transport the engineer squad and all of its weapons, tools, and equipment. The troops sit in the bowl (Fig. 14), either on canvas seats or on the squad tool boxes, and their equipment is carried in the bowl or in an amphibious trailer, which the vehicle will tow. The canvas seats can have an auxiliary function as litters; up to five of them can be easily secured and carried in the bowl. For cargo hauling, the bowl of the UET provides nearly 200 cu ft of usable space. The hydraulically actuated ejector at the rear of the bowl provides a means of self-loading (Fig. 15) and self-unloading the cargo. The ejector can exert a 14,000 lb pull to load heavy pallets, boxes, and crates or can exert a 37,000 lb push to unload them quickly and easily.

Amphibious and Fording Operations - The UET has the capability of crossing inland waterways by floating and propelling itself with its tracks (Fig. 16). No special prepara-



Fig. 14 - Engineer squad, weapons and tools in mock-up of UET

tion is required for this operation. A bilge pump is provided to remove water accumulation due to normal seepage, as well as that caused by a bullet-torn hull or a sudden wave coming over the top. Since the vehicle is only intended to be capable of crossing relatively calm waterways with ordinary stream velocities, its minimum freeboard of 14 in. with a 4000 lb load is considered adequate. For best speed while swimming, the hydraulic suspension is used to lift the tracks and roadwheels up close to the hull, where they are shrouded and cause less drag. Maximum speed of the vehicle in the water is 3-4 mph, depending upon the wear condition of the track grousers and the use of track pads. Steering of the vehicle is sluggish in the water with the transmission-steer unit powertrain, but is comparable to the armored personnel carriers. With the hydrostatic transmission, steering is considerably improved because of the ability to reverse the inside track, instead of just stopping it as with the conventional transmission.

The UET is also capable of fording to a depth of 6 ft without the use of a kit. An important feature is its ability to

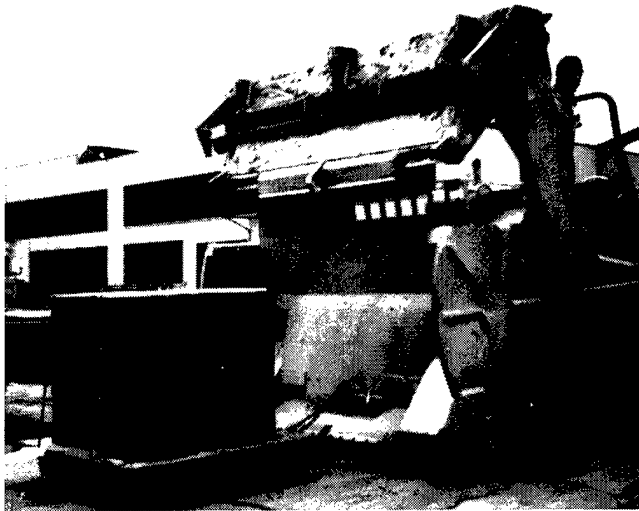

Fig. 15 - Self-loading cargo

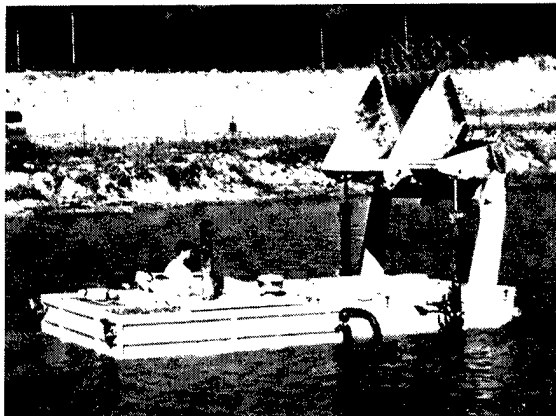

Fig. 16 - Inland amphibious capability

doze an exit for itself after reaching the far shore in a river crossing operation. This enables the UET to enter a river where it desires, not where the shore conditions dictate. To improve its dozing capability while fording, the vehicle can be ballasted with water by raising the apron.

COMPONENTS

Hull - Unnecessary weight is always an important consideration in design. It is doubly important when the design is for a vehicle which must be amphibious and meet an air-drop weight limitation. To make the UET light enough to achieve these goals required a radical departure from conventional construction equipment practices. As a result, the UET has a welded, aluminum, unit-type hull which provides the necessary structural strength for earthmoving tasks at the minimum practical weight. Aluminum alloys 5083 and 5456 are logical choices for this application because of their relative strength, toughness, weldability, and military use as armor. Steel is used for cutting edges and components where no appreciable weight savings can be achieved with aluminum.

The hulls of the E1 and E2 differ in that the latter provides approximately 4000 lb of strategically placed armor. All components, with the exception of the hulls are interchangeable, including the optional powertrains. A similar interchangeability feature could be provided with the UET-A if a lightweight hull were desired.

The aluminum armor on the UET-A and E2 provides lateral protection for troops in the bowl and full protection for the operator, equivalent to the M-113 armored personnel carrier. Operator protection in both versions is in the form of a convertible operator's compartment. The upper portion of it is hinged, swings back out of the way, and locks when not needed (Fig. 7). If armor protection is desired, the operator closes the compartment (Fig. 6) and views through vision blocks or periscopes similar to those in tanks and personnel carriers. When the compartment is closed, vision is adequate for transport operations but is limited for construction tasks. The approximate dimensions of the UET are 225 in. long, 110 in. wide, and 90 in. high, with the exception that the front bucket on the UET-A adds an additional 50 in. to its length.

Engine and Power Train - Both of the armored UET models use the same type of powertrain. The E1 differs only by the use of a hydrostatic transmission in place of the transmission-steer unit. Aluminum is used where practical to save weight in such components as housings, pans, and covers. The engine and powertrain are located in the rear half of the vehicle hull (Fig. 17). An approximately 300 gross horsepower diesel engine is located to the right of the operator and faces to the rear. It is cooled by a radiator and pusher fan at the front of the engine. The power end of the engine is connected to a transfer gear case, which drives a hydraulic pump and either the transmission-steer unit or the hydrostatic transmission. Either transmission package controls the speed range, and all steering and braking. From the trans-

mission, power is transmitted through the final drive gear reduction to the track sprockets. The sprockets turn at approximately 400 rpm for a vehicle speed of 30 mph.

Both armored versions use a manually controlled power-shift, planetary-type transmission with torque converter. A torque converter lock-out feature is available in all forward speeds. The lock-out arrangement is advantageous for this vehicle due to its broad range of work assignments. The converter is used for high drawbar tasks and lock-out is used for improved efficiency during transport type operations. Lock-out is manually selected in the UET-A, and it occurs automatically in E2 when the torque converter output shaft reaches a preset speed.

When the UET-A transmission is not locked-out, 60% of the engine torque is transmitted hydraulically through the converter, and 40% is transmitted mechanically. This split torque arrangement combines the converter's torque multiplication and antiengine stall features with the higher efficiency and improved "feel" of the direct drive.

The steer-unit portion of the transmission accomplishes all steering and braking, and supplies an additional transmission speed range. It provides both clutch-brake and geared steering, and is controlled by a steering wheel in the operator's compartment. For slow speed steering, a hydraulically actuated brake is applied to provide skid or pivot-type steering like that normally used in commercial earth-moving equipment. A geared steering arrangement is also provided since this harsh steering would not be satisfactory at higher vehicle speeds. With geared steering, hydraulically actuated planetary gear sets provide a 1.4 to 1.0 speed differential between the inner and outer tracks. This permits a more gradual turn and maintains power on the inside track, which is advantageous when traction is marginal. The geared steering permits turns from straight ahead down to a 30 ft radius. The service brakes are also actuated hydraulically.

The hydrostatic transmission used in the UET-E1 serves all of the same functions as the transmission-steer unit. It is a completely hydraulic transmission which operates on a fluid pressure rather than a fluid velocity principle, as do the torque converter and other hydrodynamic drives. Its de-

velopment was undertaken approximately two years after development of the basic vehicle, as the result of an investigation to find the type of transmission which would best provide the characteristics desired in the UET.

The power elements of the transmission consist of two variable displacement axial piston pumps with reversing wobblers, two variable displacement axial piston motors, and a two-speed gear box. The transmission is split so that one pump, one motor, and one gear box control each track. Mechanical linkages from two operator control levers to four servo controls vary the displacement of the pumps and motors on each track, to provide forward and reverse speed control and accomplish all steering and braking. Although the dynamic braking of the transmission is adequate for normal operations, disc brakes are provided for parking and emergency stops.

The main features of the hydrostatic transmission for this application are: an infinitely variable speed control from 0-30 mph; a 15 to 1 effective speed ratio, giving the capability of transmitting full horsepower from 2-30 mph; an infinitely variable turning radius from very gradual to pivot and spot turns; fully reversible speed control of each track, permitting speeds from 0-30 mph in either direction; dynamic braking; and smooth, precise control for all functions. It requires a minimum of parts and less maintenance skill than conventional transmissions, is 300 lb lighter, and its anticipated efficiency and production cost are comparable to the transmission-steer unit used in the UET.

Hydraulics - The majority of the movements and operations of the UET are accomplished through hydraulic power. On E1 and E2, the apron and ejector are operated by double acting hydraulic cylinders, the bilge pump is powered by a hydraulic motor, and any extra equipment which may be necessary could be powered hydraulically. The valves for these functions are slider-type, and are all grouped into one bank, which is manifolded to the hydraulic reservoir. This eliminates many lines and fittings, reducing possible sources of leaks as well as making unit replacement feasible. All hydraulic power is provided by a 25 gpm axial piston pump, with a maximum system pressure of 4000 psi.

On the UET-A, double acting hydraulic cylinders power the raise, lower, tilt, and clam movements of the bucket-dozer, as well as the front doors and ejector. All movements are controlled by spool valves. A hydraulic power take-off is provided at the rear of the tractor for operation of accessory equipment. The hydraulic power is supplied by two vane type pumps with flows of 12 and 53 gpm. The system has a relief valve setting of 2500 psi.

Track and Suspension - Each side of the UET has a track, four sets of roadwheels, and a rear drive sprocket. It uses a flat track design and the top portion of the track is supported and guided by large diameter roadwheels, thereby eliminating support rollers. The 28 in. diameter roadwheels are aluminum, with bonded rubber tires.

The track is a single pin, rubber bushed design (Fig. 18). For E1 and E2 it has an 18 in. wide cast steel shoe with aggressive grouser, center guide, bolt-on rubber track pad, steel

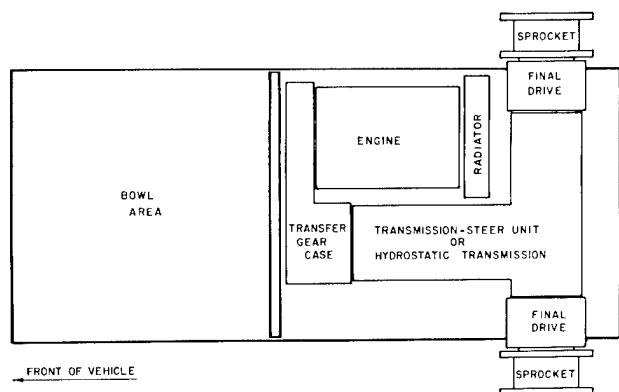

Fig. 17 - Engine and powertrain arrangement

track pins, and a weight of approximately 60 lb/ft. The UET-A track differs only in that it has a forged shoe with semi-aggressive grouser, integral pad, and aluminum track pins. The tracks are similar to those on Ordnance vehicles, except for the grouser configuration and aggressiveness. Several grouser configurations are being evaluated to determine which would be best for this vehicle.

The track pads are used to prevent damage to the roads. Both a bolt-on rubber pad and an integral steel pad, which is a permanent part of the shoe, are being evaluated (Fig. 19). The rubber pad provides a coefficient of traction of 0.65 off-road versus 0.90 for the same shoe without pads. The integral pad design has a ground pressure equal to the rubber pad and a traction coefficient of 0.65. This limits the maximum tractive ability of the machine somewhat, but offers the advantage of not having to install or remove track pads for different operations. Replacement of the bolt-on pads can be accomplished in 2 man-hr with hand tools when the tracks are clean, but cleaning them is sometimes very difficult.

Continuous high drawbar loads are a new application for rubber bushed tracks. One reason for their selection was to obtain satisfactory life during high speed operations. Another was the use of the potential stretch of the rubber bushings to keep the track tight without a compensating idler. Compensation is required since the geometry of the roadwheel travel changes the length of the track up to 4 in. when the wheels are raised and lowered. Use of the potential bushing deflection also eliminates the need for a recoil mechanism, which is normally required to prevent damage by rocks and timbers passing through the sprocket or between the track and roadwheels.

A track adjuster is provided to adjust the pre-tension in the track. This is accomplished in the UET-A model by a hydraulic grease adjuster in the front roadarm, and on E1 and E2 by rotating the final drive housing with an adjustment screw inside the hull.

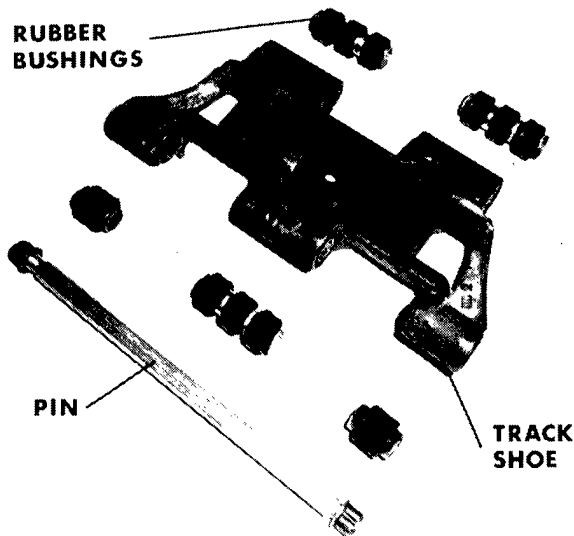

Fig. 18 - Components of single pin rubber bushed track

Both aluminum and steel track pins are being tested. The 7075 aluminum alloy pins offer a considerable weight savings over the steel pins but they bent excessively during tests, making them difficult to remove. The weight of the track shoe assemblies differ for each grouser configuration. Their weight varies from 27.5 to 33 lb each, to give a track weight between 55 and 66 lb/ft.

The drawbar capability of the vehicle with track pads is in excess of 32,000 lb on a firm clay-gravel soil. Without pads, it increases to 45,000 lb at a 50,000 lb gwv.

The key to the unusual versatility of the UET is its hydropneumatic suspension system. Designed specifically for this vehicle, it provides a compact, lightweight, and relatively simple means of fulfilling the UET's unusual suspension requirements. During transport-type operations, this system provides a resilient suspension for a smooth ride; has built in damping for control of vehicle pitching; permits load sharing between wheels to reduce the effects of shock loads; and provides automatic wheel positioning to keep the vehicle level regardless of load. For earthmoving operations, it provides the necessary rigid suspension and allows variable wheel positioning, including tilting from side-to-side. For improved mobility, the wheels can be lowered to increase the ground clearance, and for swimming they can be retracted for better propulsion.

Each vehicle uses eight nearly identical suspension units. Hydraulic power is supplied to them by a pump; a pressure regulating valve and accumulator maintain the suspension pressure without continuous pump operation. The primary difference between the suspension units of the three models is that E1 and E2 use a rotary actuator to control wheel movement, and the UET-A uses a hydraulic cylinder and radius arm arrangement. Either accomplishes the same function but in a different manner.

The suspension units of the E1 and E2 models consist of a roadarm, rotary actuator, leveling valve, wheel valve (which also houses the dampener and relief valve), and accumulator, arranged as shown in Fig. 20. In the "sprung" or resilient suspension, these units operate in the following manner to provide a comfortable ride even over rough terrain: when the roadwheel hits a bump or hole, the roadarm

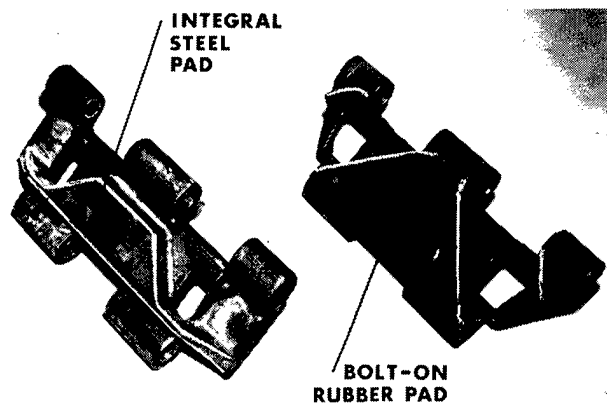

Fig. 19 - Two types of track pads

is raised or lowered; this rotates vanes in the rotary actuator, causing oil trapped between the rotating vanes and the stationary vanes to be displaced into the accumulator; the accumulator acts as a spring and absorbs the energy of the displaced oil by compressing its nitrogen gas; once the shock is absorbed, expansion of the gas forces the hydraulic oil back into the rotary actuator; this moves the roadwheel back to its original position. A hydraulic damping feature is built into the suspension system to control vehicle oscillation after striking a bump. It consists of a fixed orifice and check valve which allow damping only during the rebound portion of the bump cycle (when the roadarm is returning to its original position).

To keep the E1 or E2 level regardless of wheel loads or weight variation, three leveling valves automatically maintain the vehicle at a predetermined ground clearance. The leveling valves are actuated by a cam on the end of the roadarm shaft (Fig. 20), and supply oil to the proper side of the rotary actuator vanes when the roadarm raises or lowers from its preset position. A check valve in the system prevents a bump from opening the leveling valve.

When the E1 or E2 is loaded, its center of gravity moves forward considerably, causing a wide variation in the front wheel loadings. This requires the use of a low pressure and a high pressure accumulator on these wheels to obtain good riding qualities over the entire load range.

The suspension can be changed from sprung to rigid by actuating a valve, which blocks out all of the accumulators and the front wheel leveling valves to provide a stable platform for earthmoving operations. The operator can then independently raise or lower either or both front corners of the vehicle by actuating one set of valves. These movements are accomplished by the wheel valves which supply power to the proper side of the rotary actuator vanes to raise or lower the roadarm.

When the suspension of the E1 or E2 is in the sprung condition, front wheel travel is limited to ± 6 in. from the normal position. Retractable upstops prevent the cutting edges from penetrating the ground due to pitching caused by a violent bump.

The UET-A provides the same suspension characteristics

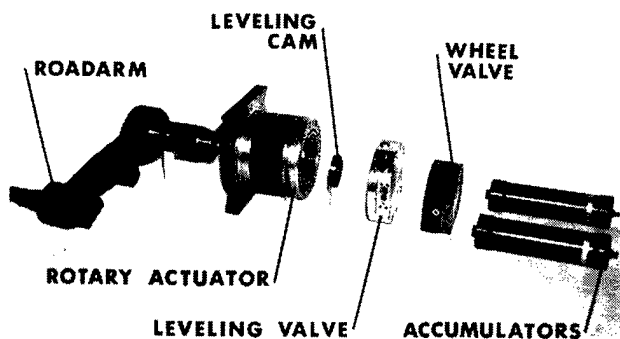

Fig. 20 - Exploded view of front suspension unit for models E1 and E2

as the E1 and E2 models. Its basic suspension unit consists of a roadarm, radius arm, suspension cylinder, leveling valve, and accumulator (Fig. 21). The accumulator is mounted "piggy-back" on the suspension cylinder and is hydraulically connected to it through a manifold, which also acts as a housing for the lock-out valve and dampener. When the suspension is sprung it operates in the following manner: the roadwheel hits a bump, raising the roadarm; this rotates the radius arm, which moves the cylinder rod and piston, displacing oil into the accumulator; once the accumulator absorbs the shock of the bump, the gas expands to its original volume and the roadwheel returns to its original position. Damping is accomplished in the UET-A suspension unit by a variable orifice between the suspension cylinder and accumulator. It provides damping in both directions of roadarm movement for normal operations. However, when a severe bump is encountered, damping occurs only during the return portion of the bump cycle.

Three leveling valves, two on the front wheels and one on the rear, automatically keep the vehicle level under any load condition during both sprung and rigid operation. The leveling valve senses the position of the roadarm by a mechanical connection to the radius arm, and either supplies oil to or releases it from the suspension cylinder to maintain a predetermined roadarm position. To prevent normal wheel movements from opening the leveling valve, a damping orifice and spring arrangement are built into the valve to delay its actuation.

Since the hull of the UET-A does not have to move in relation to the ground for dozing and scraping, none of the leveling valves are blocked out during normal operation. If desired, all leveling valves can be cut out and the vehicle can be raised or lowered parallel to the ground. The main uses for this are:

1. To raise the wheels for amphibious operation.
2. To lower the wheels for increased ground clearance.

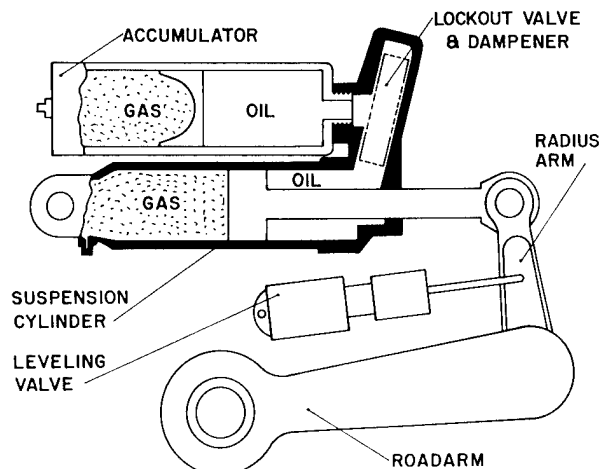

Fig. 21 - UET-A front suspension unit

3. To enable the tractor to be tilted to one side for tilting, tilt scraping, and rough grading.

The suspension is changed from sprung to rigid by actuation of the lock-out valves. This blocks out the accumulators to provide a rigid suspension for earthmoving operations.

One important feature of the UET-A suspension system is that the suspension cylinder has a gas precharge on the back side of the piston (Fig. 21). Its primary purpose is to obtain a more constant spring rate for the suspension over the entire operating weight of the tractor. It also enables the operator to raise the wheels of the vehicle (for amphibious operation) without the extra plumbing and valving which would be necessary for double acting hydraulic cylinders.

Associated Equipment - After development of the basic vehicle, several items such as a winch, crane boom, ditcher, and earth auger are planned as attachments. These, and any future accessory items which may be required will be either mounted on, or towed by the UET, and will be powered by a hydraulic or mechanical power take-off.

SUMMARY

The Universal Engineer Tractor is a lightweight, construction and transport vehicle whose major attribute is versatility. Its flexible configuration combined with creative engineering have achieved this versatility without excessive complexity, to make the UET a practical multipurpose vehicle. Intended as the primary work tool for the engineer squad, the UET will provide an increased construction and transport capability, greater mobility, and personnel protection as well as logistical simplification.

REFERENCES

1. T. G. Timberlake, R. G. Alexander, N. P. Oglesby, and W. H. Leathers, "Futurarmy Engineer Construction Equipment." Paper presented at SAE FCIM Meeting, September 1958.
2. R. Reynolds and E. Mayer, "High Pressure Hydropneumatic Suspension of the Universal Engineer Crawler Tractor." Paper presented at SAE Heavy Duty Vehicle Meeting, September 1961.