

30 January 1990

# Working Paper

---

WP FH90-1

MAXIMIZING MOBILE SUBSCRIBER EQUIPMENT SYSTEM EFFECTIVENESS THROUGH PERSONNEL  
SELECTION AND PERFORMANCE ASSESSMENT: AN INTERIM REPORT

Louis W. Buckalew

**Reproduced From  
Best Available Copy**

**DISTRIBUTION STATEMENT A**  
Approved for Public Release  
Distribution Unlimited

Reviewed by: Charles O. Nystrom  
CHARLES O. NYSTROM  
Leader, Weapons System  
Evaluation Team

Approved by: George M. Gividen  
GEORGE M. GIVIDEN  
Chief, Fort Hood Field Unit

Cleared by: Robin L. Keesee  
ROBIN L. KEESEE  
Director  
Systems Research Laboratory

20011018 079



**U.S. Army Research Institute  
for the Behavioral and Social Sciences  
5001 Eisenhower Avenue, Alexandria, VA 22333-5600**

---

This working paper is an unofficial document intended for limited distribution to obtain comments. The views, opinions, and findings contained in this document are those of the author(s) and should not be construed as the official position of the U.S. Army Research Institute or as an official Department of the Army position, policy, or decision.

MAXIMIZING MOBILE SUBSCRIBER EQUIPMENT SYSTEM EFFECTIVENESS  
THROUGH PERSONNEL SELECTION AND PERFORMANCE ASSESSMENT: AN INTERIM REPORT

CONTENTS

	Page
Summary . . . . .	1
Introduction. . . . .	1
Background . . . . .	1
System Description . . . . .	2
Purpose of Research. . . . .	5
Method. . . . .	5
Operators. . . . .	5
Instruments and Equipment. . . . .	7
Procedure. . . . .	7
Results . . . . .	8
Discussion. . . . .	15
Limitations. . . . .	15
Findings . . . . .	16
References. . . . .	18

List of Tables

1. Physical Components and Functions of MSE Assemblages. . . . .	3
2. Distribution of MSE Feeder MOSs within the Fort Gordon Sample . . .	6
3. Summary Personnel Characteristics of Fort Gordon Sample . . . . .	6
4. MSE Operator Performances for Sampled Tasks . . . . .	9
5. Significant Relationships ( $p < .10$ ): Personnel and Performance Variables . . . . .	10
6. Performance Variance Accountability (75%) Predictor Variables . . .	11
7. Performance Variance Accountability (75%) Predictor Variables for Selection . . . . .	12
8. Best Available Performance Prediction Equations . . . . .	13

CONTENTS (Continued)

---

	Page
9. Best Available Performance-Based Prediction Equations for Selection	14

List of Figures

1. Diagram of functional relationship of MSE and user-unit equipment .	4
--	---

MAXIMIZING MOBILE SUBSCRIBER EQUIPMENT SYSTEM EFFECTIVENESS  
THROUGH PERSONNEL SELECTION AND PERFORMANCE ASSESSMENT: AN INTERIM REPORT

Summary

The Mobile Subscriber Equipment (MSE) acquisition is one of the Army's largest current procurement programs and requires the formation of three new MOSs: MSE Transmission Systems Operator (31D), MSE Network Switching System Operator (31F), and MSE Communications Chief (31W). Due to the new and high technology equipment, the vastly enhanced communications capabilities, and the training demands of the MSE system, it is critical that operator personnel selection be efficient and that operator training be effective. This research supports two major goals: (a) to identify personnel variables which are predictive of MSE operator performance to support efficient personnel selection (31D and 31F), and (b) to develop quantitative operator performance criteria which can be used as standards for training outcomes and Skills Qualification Tests. A signal battalion trained and fielded with MSE constituted the sample. Personnel data analyzed included ASVAB scores (GT, EL, SC), educational level, computer experience, age, gender, time in service, handedness, wearing of glasses, MSE knowledge test score, and training evaluation rating. Time and error measures were collected on 31D tasks of initializing a Radio Access Unit (RAU), loading Digital Secure Voice Terminals (DSVTs), and affiliating Group Logic Units (GLUs); 31F tasks measured were sending and receiving an Over-the-Air Rekey (OTAR). Performance times and error rates are provided, a number of potential predictor variables are identified, and prediction equations for most tasks are offered. These findings will be exercised and a broader range of operator tasks sought during conduct of the MSE Follow-on Operational Evaluation (FOE) by OTEA.

Introduction

Background

The U.S. Army is increasingly integrating high technology systems as it upgrades and modernizes equipment. Owing to the rapid advancement of technology, new systems which replace older ones are placing greater demands upon the soldier, particularly of a cognitive nature, for the operation and maintenance of state-of-the-art equipment. These demands are major concerns within the Army relative to the selection and training of soldiers who are expected to effectively utilize increasingly complex systems. These concerns are aggravated by a dwindling proportion of service-age persons in the population, an increasing demand for persons with above average mental abilities, and competition from the private sector for workforce. The field of communications is a good example within the Army of personnel supply and demand constraints coupled with an increasingly complex technology. Prime examples of the Army's new and more demanding communications systems are the Single Channel Ground and Airborne Radio System (SINGARS) and the Mobile Subscriber Equipment (MSE).

In response to concerns for personnel availability and high technology equipment training requirements, the Commanding General of the Training and

Doctrine Command (TRADOC) in Nov 87 requested Army Research Institute (ARI) assistance in personnel selection and training related to the fielding and integration of MSE. MSE is a nondevelopmental acquisition program, and as such has not evolved through the rigorous research and development sequence typical of major new Army systems. In essence, MSE must be made operational with minimal changes to equipment (engineering) and force structure (personnel). This requirement places a significant demand on appropriate research organizations to provide information and guidance to decision makers on how to integrate and operationalize a major system under a scenario of appreciable personnel and training constraints. ARI, among others, is responding to this challenge.

### System Description

MSE is a new battlefield communications system slated to become the backbone of Army corps and division communications. The system is being procured through GTE and has been fielded at Fort Hood, Texas and Fort Gordon, Georgia. It is anticipated that approximately 18,000 soldiers will be MSE-trained, with fielding through FY93 to involve over 50 signal battalions. It is intended that this system will constitute the mainstay of Army battlefield communications into the 21st century. Accordingly, the research, engineering, and training communities must support and ensure the effective transition, deployment, and utilization of the MSE system.

MSE integrates the functions of transmission, switching, control, communications security, and both voice and data terminal equipment into one system. As a switched telecommunications system, MSE is extended by mobile radiotelephone and wire access. Table 1 summarizes the physical components of MSE and the major operational responsibilities of each.

The heart of the MSE system is node center switches (NCSs). These centers provide connections to large extension node switches (LENS), small extension node switches (SENS), and radio access units (RAUs) and are linked together by line-of-sight radio trunks (LOSs). Extension switches (LENS and SENS) allow wire line terminal subscribers (telephone, facsimile, and data) to enter the system. Radio access units (RAUs) provide mobile radiotelephone users an interface to MSE and the ability, through an NCS, to communicate with other mobile and wire telephone users. System control centers (SCCs) provide processing capability for data inputs to aid in network management. Figure 1 illustrates how MSE components interrelate.

MSE subscriber service, equipment of which is user-owned, is facilitated by digital nonsecure voice terminals (DNVTs) and mobile subscriber radiotelephone terminals (MSRTs). MSE is intended to be capable of interfacing with other communications systems, to include combat net radio (CNR) users (SINCGARS), NATO and allied military systems, and host nation commercial telephone systems. The major components of MSE (NCS, SCC, LENS, SENS, RAU, and LOS) are self-contained assemblages configured in wheeled vans (HMMWV). Major auxiliary equipment for MSE includes generators, 15 and 30 meter masts, and various antennas. Detailed information on MSE system components is available in FM 11-999E, "Mobile Subscriber Equipment (MSE) Architecture."

Table 1

## Physical Components and Functions of MSE Assemblages

Component	Function	Operator MOS
Radio Access Unit (RAU)	<ul style="list-style-type: none"> <li>- Connects system through NCSs when relocating</li> <li>- Provides mobile subscriber access</li> <li>- Can function as an MSRT</li> </ul>	31D
Line-of-Sight (LOS) Radio	<ul style="list-style-type: none"> <li>- Connects SENS and LENS to NCS</li> <li>- Connects node center switches</li> <li>- Allows remoting of SENS, LENS, and RAU</li> <li>- Can connect RAUs to NCSs</li> <li>- Provides UHF functions required at SENS, LENS, and NCS</li> </ul>	31D
Small Extension Node Switch (SENS)	<ul style="list-style-type: none"> <li>- Interface with combat net radios</li> <li>- Commercial interface</li> <li>- Serves unit command posts</li> <li>- Provides access to wire subscribers</li> </ul>	31F
Large Extension Node Switch (LENS)	<ul style="list-style-type: none"> <li>- Interface with combat net radios</li> <li>- Commercial interface</li> <li>- Supports larger concentrations of users</li> </ul>	31F
Node Center Switch (NCS)	<ul style="list-style-type: none"> <li>- Maintains list of local subscribers</li> <li>- Hub of a commo node</li> <li>- Directly services signal command and control elements</li> <li>- Provides network switching</li> </ul>	31F/W
System Control Center (SCC)	<ul style="list-style-type: none"> <li>- Network management</li> <li>- Connected to NCS</li> </ul>	31W

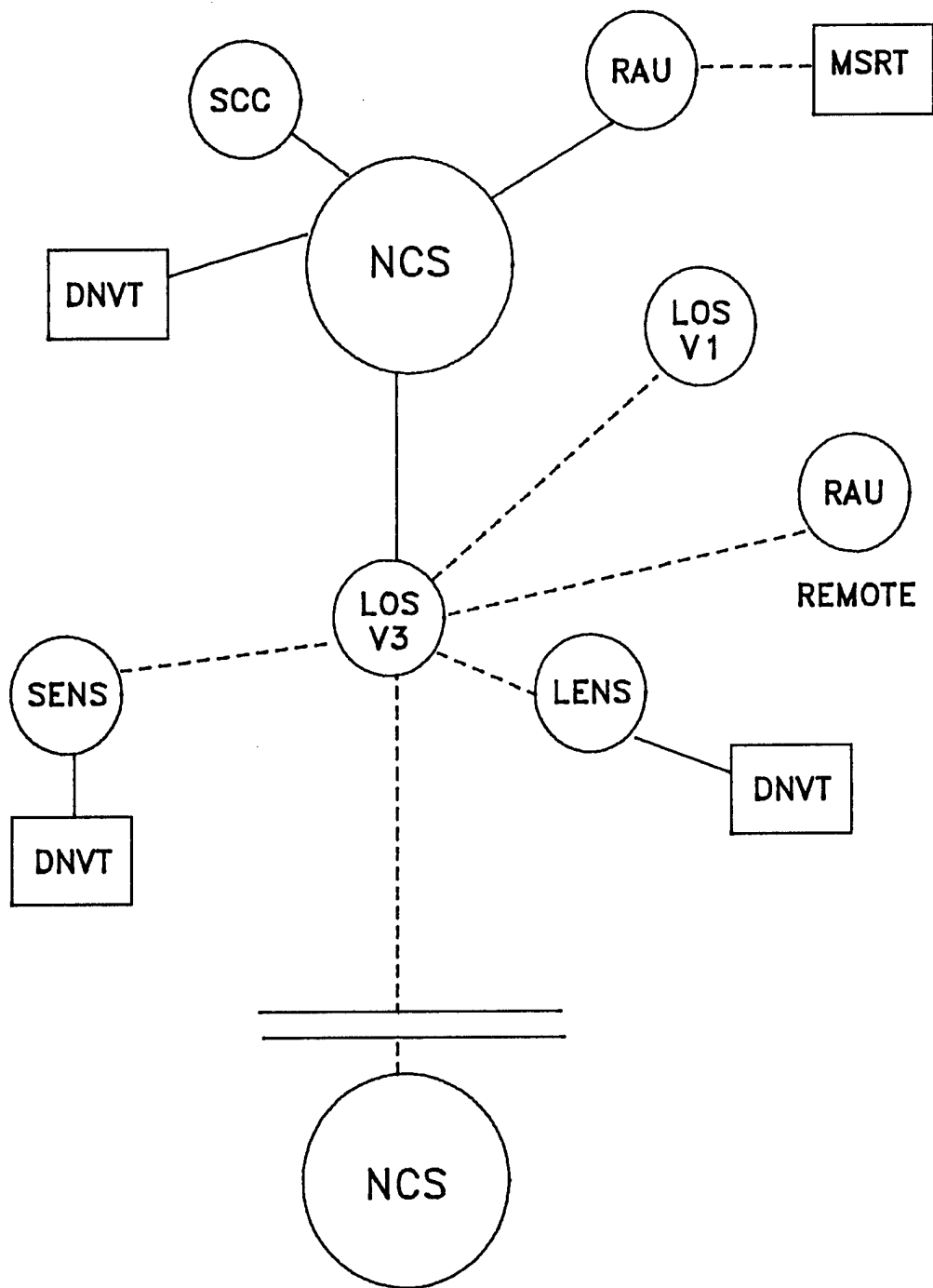

Figure 1. Diagram of functional relationship of MSE and user-unit equipment. A typical node consists of an NCS, 5 SENS, 2 RAUs and several LOS radios, is operated by a platoon, and is capable of handling 130 wire and 40 mobile subscribers.

## Purpose of Research

The purpose of this research effort was to contribute towards Army needs for information and guidance relative to MSE operator personnel selection strategies, operator performance standards, and training requirements. It deals specifically with July 1989 ARI research on MSE operator performance and training decay utilizing personnel from an MSE-fielded signal battalion at Fort Gordon, Georgia. This research expands on preliminary findings of the MSE Follow-on Operational Test and Evaluation (FOTE) conducted at Fort Hood, Texas during the summer and fall of 1988.

Exploratory personnel and performance data collected under the auspices of the MSE FOTE and contributed by the Army Operational Test and Evaluation Agency (OTEA) were reported by Buckalew, Smootz, Glaze, and Sanders (1989). Data collected at Fort Gordon and reported herein are based on directions suggested by the earlier FOTE data analysis. It is cautioned that the findings of this report are interim. However, these findings suggest specific data collection efforts intended for the MSE Follow-on Operational Evaluation (FOE) scheduled for the 2nd QTR 90. Specific attention is directed at 31D and 31F MOSSs. Incorporating viable findings from the MSE FOE, composite results can be translated into suggested MSE personnel selection strategies, to include reslotting of current communications MOS soldiers, suggested performance standards (end of training and SQT) for MSE MOS soldiers, and integration into the Electronic Proving Ground's (EPG) computer simulated model of MSE system performance. Primary responsibility for personnel classification strategy input resides with the ARI Fort Gordon Field Unit, and responsibility for deriving operator performance algorithms for integration into the EPG MSE model resides with the ARI Fort Hood Field Unit. Suggestions for MSE operator performance standards are shared responsibilities of these two ARI Field Units.

## Method

### Operators

Personnel and performance data were provided through OTEA for 280 soldiers transitioned into 31D, 31F, and 31W MOSSs during the conduct of the earlier MSE FOTE. Related data were obtained from 44 soldiers transitioned into 31D and 31F MOSSs at Fort Gordon. The FOTE group had 159 transitioned into 31D and 88 transitioned into 31F, 86% of whom were men. The Fort Gordon group (FG) involved 22 transitioned into the 31D and 22 transitioned into the 31F MOSSs, 71% of whom were men. Feeder MOSSs for the FOTE group were: 25B, 31C, 31G, 31K, 31L, 31M, 31N, 31Q, 31V, 31Y, 31Z, 36C, 36L, 36M, and 72E. For the FG group, feeder MOSSs included 31C, 31K, 31L, 31M, 31N, and 36M.

Table 2 shows the distribution of feeder MOSSs for the FG group. In both FOTE and FG groups, the largest proportion of soldiers (49% and 60%) came from the 31M feeder MOS. For the FOTE group, ages ranged from 19 to 45 years, time in service ranged from 1 to 20 years, and education ranged from 9 to 17 years. For the FG group, ages ranged from 19 to 37 years, time in service ranged from 1 to 17 years, and education ranged from 11 to 16 years.

Table 2

## Distribution of MSE Feeder MOSs within the Fort Gordon Sample

Prior MOS	31D (N=22)	31F (N=22)
31C	9.5%	9.1%
31K	14.3%	4.5%
31L	9.5%	13.6%
31M	66.7%	54.5%
31N	---	4.5%
36M	---	13.6%

ASVAB standardized test scores ranged from 59 to 155 on the GT scale and 76 to 141 on the EL scale for FOTE soldiers and 90 to 133 on both scales for the FG group. The FG group ranged from 79 to 128 on the SC scale (data not available for FOTE group). For the FOTE group, 90% and for the FG group, 86% were right-handed. In the FG group, 28% wore glasses (data not available for the FOTE group). These data suggest, allowing for a reduced FG sample size, similar sample characteristics in terms of personnel variables. Table 3 summarizes the personnel characteristics of the 31D and 31F soldiers who constituted the Fort Gordon sample. Similar data for the earlier FOTE group is available (Buckalew et al., 1989).

Table 3

## Summary Personnel Characteristics of Fort Gordon Sample

Variable	31D MOS (N=22)	31F MOS (N=22)
Gender	59% men	82% men
Mean Age	22.6 (19.9-31.0)	26.5 (19.7-36.6)
Time in Service	4.1 (1.1-8.8)	6.9 (1.3-16.5)
Education	12.1 (12-14)	12.5 (11-16)
Handedness	86% right	86% right
Glasses	27% yes	29% yes
ASVAB GT Mean	108.2 (90-130)	115.5 (98-133)
ASVAB EL Mean	106.0 (90-124)	111.4 (95-133)
ASVAB SC Mean	105.7 (89-125)	110.3 (79-128)
MSE Test Mean	40.9% (23-59)	53.4% (27-73)
Training Rating	2.3 (1.4-3.3)	2.5 (1.6-3.8)
Computer Experience	59% (little or no)	45% (little or no)
Feeder MOSs	31C, 31K, 31L, 31M	31C, 31K, 31L, 31M, 31N, 36M

## Instruments and Equipment

A single RAU and two NCSs were used to support operator task performance testing. Ancillary equipment included two diesel-powered generators and necessary cabling between assemblages. An operator personnel data collection form was administered to soldiers to obtain information on individual backgrounds excepting ASVAB scores. These standard scores were obtained from unit personnel records. The MSE Knowledge Test, an objective paper-and-pencil test developed by ARI, was administered in a monitored classroom environment and emphasized the integration of 31D and 31F collective knowledge. A manpower, personnel, and training evaluation questionnaire developed by ARI involving 17 training items using a 5-point "adequacy" rating scale (strongly agree = 1 through strongly disagree = 5) was also administered in a monitored classroom environment. Clipboards were provided to each soldier. Stopwatches were used to obtain time measurements on operator tasks and structured data collection forms were used for recording time and error data. Operators were allowed to consult MSE technical manuals and any available unit SOPs.

## Procedure

The FOTE data analyses constituted Phase 1 (FOTE) of this research project and were intended to provide suggested directions for further research. Data collection at Fort Gordon (Phase 2) was intended to generate hypotheses for which data would be collected later. Phase 3 (FOE) of this project will involve the collection and analysis of operator personnel and performance data suggested (Phase 1 and 2) as relevant to personnel selection and performance concerns. Phase 1 data suggested potentially rewarding areas of personnel and performance data collection, Phase 2 data were intended to generate hypotheses as to personnel and performance interrelationships, and Phase 3 data are intended to empirically expand and confirm or disconfirm hypotheses on personnel characteristics and performance. Respecting directions suggested by Phase 2 data, Phase 3 (FOE) data collection and analyses should provide valid personnel (31D, 31F) selection strategies and performance algorithms in terms of task completion times and errors.

Personnel and performance data obtained from the MSE FOTE were provided by a contractor and without controls for, in the case of performance, the number or identity of soldiers participating in a given task. As a result, interpretation of FOTE operator performance data was limited by collection techniques. Data collection at Fort Gordon was accomplished by ARI research psychologists and was dedicated to specific concerns with designated MSE tasks and operator personnel variables. While the Fort Gordon operator and MSE task samples were definitively smaller than those of the MSE FOTE, the Fort Gordon data are more valid.

MSE FOTE operator performance data were, as discussed by Buckalew et al. (1989), limited by assignment of task performance times collectively to all soldiers involved. This practice precluded meaningful identification of specific personnel variables associated with a MSE task performance. The Fort Gordon research effort delineated specific MSE task performances with specific soldiers. This allowed for meaningful associations between soldier personnel characteristics and selected MSE performances (31D and 31F tasks). Soldier

performances on selected tasks were measured in a motorpool under controlled conditions (scenarios). Data were collected and recorded by ARI research psychologists aided by senior NCO Subject Matter Experts (SMEs) who provided information on errors committed and the adequacy of task performance. Testing followed MSE training and a unit FTX. Prior to performance testing, personnel data, training evaluation ratings, and MSE Knowledge Test data were obtained in a controlled environment (battalion classroom). Soldiers were informed of the purpose of the research.

Operator Tasks. Because of constraints imposed by the small number of data collectors and SMEs and the availability of trained operators and equipment, only a narrow range of operator tasks could be assessed within each MSE MOS (31D and 31F). The 31D task measured for completion time and error was to initialize a Radio Access Unit (RAU). Subtasks for which discrete time and error measures were obtained were: load RT-1539s (8), load and affiliate the Digital Secure Voice Terminal (DSVT), and affiliate the Group Logic Unit (GLU) to include loading frequency plans. For the 31F MOS, the tasks of sending an Over-the-Air Rekey (OTAR) and receiving an OTAR were measured for completion time and error.

Scoring. For performance testing, timing began when the operator acknowledged understanding the assigned task and ended when the task was: (a) successfully completed according to an SME, (b) terminated due to an uncorrected error based on SME feedback, or (c) terminated due to an equipment problem. The "Go/No-Go" evaluations of SMEs are not reported in this paper or used in computing error rates, as operators often had errors corrected by other soldiers or an SME and were allowed to proceed with a task ultimately rated "Go" by an SME. Some task times were lengthened by operators correcting an error and having to redo one or more subtasks. Errors on a task were coded "1" = No and "2" = Yes. The MSE Knowledge Test was administered and scored by ARI (Training Research Lab) personnel and the composite percent correct was entered into the data base. The Training Evaluation section (17 items) of a larger Manpower, Personnel, and Training (MPT) questionnaire yielded coded responses from 1 (strongly agree) through 5 (strongly disagree). A composite mean rating was computed and entered in the data base. The Operator Personnel Information form completed by soldiers allowed most data to be directly entered into the data base. The wearing of glasses was coded "1" (Yes) or "2" (No), gender was coded "1" (male) or "2" (female), hand preference was coded "1" (left) or "2" (right), and computer experience was coded from "1" (extensive) through "5" (none).

## Results

The intent of this exploratory study, based on guidance provided by exploratory FOTE data analyses, was to identify meaningful relationships between selected personnel variables, as listed in Table 3, and a sample of 31D and 31F operator task performances. In addition, data were collected by interview of MSE SMEs and administration of an ARI-designed MSE Knowledge Test to allow modeling and evaluation of MSE operator skill decay. Findings of the skill decay research effort are published separately (Sabol, Chapell, & Meiers, in preparation). Personnel and performance relationships

identified are intended for more detailed evaluation and validation during the MSE FOE planned for 2QTR FY90

Table 4 describes MSE operator (31D and 31F) performances on measured tasks in terms of completion time and proportion of operators who committed an error. It must be noted that, while the personnel data base in this study was  $n = 22$  for each (31D and 31F) MOS, sample sizes for any specific task performance ranged from  $n = 8$  to  $n = 13$ .

Table 4

MSE Operator Performances for Sampled Tasks

Task	<u>N</u>	Completion Time Mean and (SD)	Operators Making Error
Initialize RAU*	13	18.7 min (6.8)	39%
Load RT-1539s	12	2.0 min (1.5)	25%
Load DSVT	9	1.3 min (.9)	10%
Affiliate GIU	11	2.8 min (1.7)	25%
Send OTAR*	9	8.0 min (3.4)	56%
Receive OTAR*	8	7.1 min (4.7)	38%

\*RAU tasks performed by MOS 31D; OTAR tasks performed by MOS 31F.

Statistically significant ( $p < .10$ ) Pearson product-moment correlations between personnel variables and performances are listed in Table 5. Given this level of probability, the matrix of 31F personnel and performance variables (12 and 4 respectively) would be expected to produce 4.8 significant correlations, and 5 were realized. For the 31D matrix of 96 personnel and performance variable combinations, 9.6 significant correlations were expected and 11 were realized. Actual correlation significance levels ranged from .085 to .001 in both matrices, and a majority (81%) of correlation coefficients were significant if a .06 level of significance was applied.

Table 5

Significant Relationships ( $p < .10$ ): Personnel and Performance Variables

Task	<u>N</u>	Performance Variables ( $r$ )
Initialize RAU Time	13	Age (.61), Time in Service (.70)
Load RT-1539s	12	None
Load DSVT	9	MSE Knowledge Test (.78)
Affiliate GIU	11	Age (.62), Time in Service (.57)
Error Initializing RAU*	13	Age (.50), Time in Service (.55), ASVAB EL (-.58), ASVAB SC (-.69), Glasses (-.84)
Error Loading RT-1539s*	12	ASVAB SC (-.64)
Error Loading DSVT*	10	None
Error Affiliating GIU*	11	None
Send OTAR Time	9	None
Error Sending OTAR*	9	ASVAB EL (.77)
Receive OTAR Time	8	Age (-.69), Time in Service (-.70), Hand (-.74)
Error Receiving OTAR*	8	Glasses (-.75)

\* Errors were coded "1" = No and "2" = Yes

Acknowledging the goal of this research and that prediction is an attempt to account for the variability in one variable based on knowledge of another, it was of interest to determine what combination of predictors (personnel variables) could account for a specified proportion of MSE task performance variability. A criterion of 75% of variance accountability was arbitrarily assigned and a SAS regression model (R square) was applied to all predictors (personnel variables) for each operator task performance (time and error). Table 6 shows the outcome of this analysis considering all available personnel variables, and Table 7 shows results of this analysis considering only those measures available prior to MOS slotting (excludes MSE Knowledge Test score and training rating), i.e., a personnel selection perspective. While the data of Table 5 suggest a number of discrete variables, and those of Tables 6 and 7 suggest criterion-referenced combinations of variables, for prediction of selected MSE operator performance, it was acknowledged that these predictor variables are interrelated.

Table 6

## Performance Variance Accountability (75%) Predictor Variables

Task	Measure	Predictor Combination	*Variance Accounted for
Initialize RAU	Time	Time in Service + ASVAB EL + MSE Knowledge Test + Education	76%
	Error	Glasses + ASVAB SC	80%
Load RT-1539s	Time	Glasses + Time in Service + Age + ASVAB EL + ASVAB GT	91%
	Error	ASVAB SC + Education + Time in Service	76%
Load DSVT	Time	MSE Knowledge Test + Age	89%
	Error	N/A	
Affiliate GIU	Time	Training Rating + Age + ASVAB GT	88%
	Error	ASVAB EL + Hand + Time in Service + Age	82%
Send OTAR	Time	MSE Knowledge Test + ASVAB GT + Computer Experience	95%
	Error	ASVAB EL + ASVAB GT	97%
Receive OTAR	Time	Glasses	81%
	Error	Glasses	100%

\* The SAS multiple regression program treatment of missing values for a subject on any variable causes that subject's data on all variables to be disregarded. Hence, Ns for Table 6 data may be less than Ns for Table 5 data. Thus, the variance accounted for as listed for a predictor in Table 6 or 7 may not be equal to the square of the correlation for that variable as listed in Table 5.

Table 7

## Performance Variance Accountability (75%) Predictor Variables for Selection

Task	Measure	Predictor Combination	Variance Accounted for
Initialize RAU	Time	None	N/A
	Error	ASVAB SC + Glasses	79%
Load RT-1539s	Time	Age + Time in Service + ASVAB EL + ASVAB GT + Glasses	87%
	Error	Age + Education + ASVAB EL + ASVAB SC	86%
Load DSVT	Time	ASVAB EL + ASVAB GT	84%
	Error	Age + Time in Service + ASVAB SC	79%
Affiliate GIU	Time	Gender + Age + Time in Service + Education + ASVAB EL	78%
	Error	Age + Time in Service + Hand + ASVAB EL + ASVAB GT	90%
Send OTAR	Time	Gender + Time in Service + ASVAB GT + ASVAB SC	92%
	Error	ASVAB EL + ASVAB GT	97%
Receive OTAR	Time	Glasses	81%
	Error	Glasses	100%

The goal of this exploratory research, beyond identifying individual and combination MSE performance predictor variables, was to provide insight for MSE operator personnel selection strategies and performance algorithms. The desirable outcome was tentative operator performance prediction equations for those tasks selected for study. To satisfy this requirement, stepwise multiple correlation techniques were applied to obtain the most effective combination of personnel variables in predicting task time and error performance within this sample. The criteria that a predictor variable must have a significance level of  $p < .50$  for entry into the model and an independent probability level of  $p < .15$  to be retained in the model were applied through a multiple regression program (SAS stepwise regression procedure). Table 8 summarizes the outcome of this statistical procedure in terms of prediction equations for specific MSE task performance (time and error) using weighted predictor variables. Table 9 provides similar products though considering only those measures available prior to MOS slotting to support a personnel selection perspective.

Table 8

## Best Available Performance Prediction Equations\*

Task	Measure	Variables and Weights	$R^2$	F	p
Initialize RAU	Time	12.26 + 1.93 Time in Service	.46	8.7	.015
	Error	4.39 - .02 ASVAB SC - .66 Glasses	.80	17.9	<.001
Load RT-1539s	Time	-2.57 + .32 Time in Service + 2.13 Glasses	.38	2.4	.153
	Error	3.81 + .11 Time in Service - .45 Education + .04 ASVAB GT - .05 ASVAB SC	.88	10.9	.007
Load DSVT	Time	-.62 + .05 Age + .03 MSE Knowledge Test - .29 Training Rating	.96	32.2	.003
	Error	N/A	—	—	—
Affiliate GLJ	Time	-13.42 - .88 Gender + .31 Age - .04 MSE Knowledge Test + .17 ASVAB GT - 2.84 Training Rating	.97	31.1	.003
	Error	-.33 + .39 Education	.26	2.8	.133
Send OTAR	Time	1.38 + .11 MSE Knowledge Test	.25	1.7	.254
	Error	-1.46 + .08 ASVAB EL - .05 ASVAB GT + .17 Glasses	.99	85.3	.002
Receive OTAR	Time	24.02 - .02 Time in Service - 2.57 Education - .03 Training Rating - 7.89 Glasses + 2.47 Computer Experience	1.00	>999	<.001
	Error	3.00 - 1.00 Glasses	1.00	>999	<.001

\* Variables must meet .50 significance level for entry and .15 significance level for retention in model.

Table 9

## Best Available Performance-Based Prediction Equations for Selection\*

Task	Measure	Variables and Weights	R <sup>2</sup>	F	p
Initialize RAU	Time	11.80 + 2.00 Time in Service	.48	10.3	.008
	Error	4.30 - .02 ASVAB SC - .70 Glasses	.79	19.2	<.001
Load RT-1539s	Time	10.00 - .63 Age + 1.12 Time in Service + 1.53 Glasses	.59	3.9	.056
	Error	6.12 + .13 Time in Service - .63 Education + .02 ASVAB GT - .04 ASVAB SC - .18 Computer Experience	.91	11.6	.005
Load DSVT	Time	4.11 + .34 Age - .61 Time in Service + .25 ASVAB EL - .30 ASVAB GT - 1.51 Glasses	.99	62.3	.003
	Error	2.28 - .01 ASVAB SC	.11	1.0	.342
Affiliate GIU	Time	- 3.56 + .27 Age	.39	5.8	.040
	Error	- .40 + .40 Education	.27	3.3	.104
Send OTAR	Time	1.67 + .23 Age	.17	1.1	.351
	Error	N/A	---	---	---
Receive OTAR	Time	22.63 - .03 Time in Service - 2.44 Education - 7.73 Glasses + 2.63 Computer Experience	1.00	>999	.001
	Error	3.00 - 1.00 Glasses	1.00	>999	<.001

\* Variables must meet .50 significance level for entry and .15 significance level for retention in model.

Information was available on an additional potential predictor variable of prior (feeder) MOS. As a major concern in reslotting considerations, prior MOS was explored through regression analysis techniques (SAS general linear models procedure) to determine its impact on MSE operator performances. Given any significant ( $p < .05$ )  $F$  value for the effect of prior MOS on MSE performance (time and error),  $t$  tests were applied to compare prior (feeder) MOS groups on MSE task performances (means). For 31F MOS tasks (time and error measures of send and receive OTARs), there were no differences among prior MOS groups. For 31D tasks (time and error measures of initializing a RAU and subtasks of loading RT-1539s, affiliating the GIU, and loading DSVT), only loading RT-1539s showed any differences among feeder MOSs. Persons with a 31K prior MOS

were significantly ( $p < .05$ ) faster than 31C, 31L, and 31M prior MOS groups, though they made more errors ( $p < .05$ ) than 31L and 31M MOS groups.

### Discussion

MSE FOTE data, as presented by Garretson (1988), were explored by Buckalew et al. (1989) to suggest potentially profitable directions for personnel selection strategy research efforts. Based on guidance from these sources, the present research effort was conducted to provide hypotheses for personnel selection, training standards, and operator performance algorithms to be more fully explored during the conduct of the MSE FOE. It is anticipated that data collection efforts associated with the FOE will explore the personnel variables identified herein as "predictors" and will expand the task performance data base for 31D and 31F MOS soldiers to include additional "critical" tasks such as orienting antennas, initializing the LOS, NCS, LENS, and SENS, and performing selected operational subtasks on each assemblage.

Based on reported findings, there appears to be valuable information available for consideration by decision makers involved in personnel selection and setting training standards. Respecting limitations of small samples of both 31D and 31F MOSs and a restricted range of operator performance tasks, present findings suggest the efficacy of an expanded research effort to be accomplished during the MSE FOE to broaden the operator task performance data base. Within the small data base of this research effort, certain personnel characteristics were identified as potentially viable predictors of selected MSE task performances and may deserve attention in reslotting personnel to accommodate MSE system requirements. Prior to consideration of present specific findings, limitations on these findings must be clearly stated and it must be reiterated that this study was conducted as an exploratory effort to identify variables and relationships of interest for future (FOE) and expanded study.

### Limitations

The operator personnel data base for each MOS (31D and 31F) contained information on only 22 soldiers. No soldier was included in any task-specific performance data base unless personnel data were available. Because of time restrictions on personnel and equipment availability, not all the 22 soldiers in each MOS were tested for task performance; sample sizes for each major task (initialize RAU, send OTAR, and receive OTAR) ranged from 8 to 13. Interpretation of some data (relationships) must carefully attend to how data were scored or coded for computer entry, as identified in the Scoring subsection of the Method portion of this report. Also, the influence of SME evaluators' and other soldiers' prompts on tested operators' time and error performances is not fully known. It must be stated that, while all 31D operators were trained on the RAU, an undetermined number had operated only the LOS since training. Beyond consequences for measured performances on the RAU, this fact has appreciable implications for unit sustainment training needs and operator skill decay.

## Findings

The following are offered as tentative findings and conclusions based on the small samples of operators and tasks assessed. All findings are subject to verification in future planned testing (FOE).

- o The 5th and 95th percentile times for accomplishing a send OTAR task (31F) are 2.4 minutes and 13.5 minutes, respectively;
- o The probability of error in sending an OTAR is approximately 55%;
- o The 5th and 95th percentile times for accomplishing a receive OTAR task (31F) are <1 minute and 14.8 minutes, respectively;
- o The probability of error in receiving an OTAR is approximately 38%;
- o The 5th and 95th percentile times for initializing a RAU (31D) are 7.5 minutes and 30 minutes, respectively;
- o The probability of error in initializing a RAU is approximately 39%;
- o The 5th and 95th percentile times for loading RT-1539s (31D) are <1 minute and 3.7 minutes, respectively;
- o The probability of error in loading RT-1539s is approximately 25%;
- o The 5th and 95th percentile times for loading a DSVT (31D) are <1 minute and 2.8 minutes, respectively;
- o The probability of error in loading a DSVT is 10%;
- o The 5th and 95th percentile times for affiliating the GIU (31D) are <1 minute and 5.5 minutes, respectively;
- o The probability of error in affiliating a GIU is 25%;
- o Time in service, ASVAB SC, wearing of glasses, ASVAB EL, education, age, MSE Knowledge Test score, training evaluation rating, ASVAB GT, and handedness appear as potentially viable predictors for sampled 31D task performances;
- o Wearing of glasses, ASVAB GT, MSE Knowledge Test score, ASVAB EL, and computer experience appear as potentially viable predictors for sampled 31F tasks;
- o Significant (variance accountability) prediction equations exist for time or error performance in initializing a RAU (31D) and subtasks of loading RT-1539s, loading DSVTs, and affiliating GIUs;

- o Significant (variance accountability) prediction equations exist for time and error performances in sending or receiving an OTAR (31F);
- o ASVAB scores, particularly EL and SC, appear to be more viable predictors of performance error than for performance time.

Present findings need to be validated and supplemented by the expanded operator task base (31D and 31F) data collection opportunity available through conduct of the MSE FOE. OTEA, as the testing agency, has expressed strong support of such an effort and is supporting the collection of appropriate data. Final MSE operator performance data analyses will be provided to OTEA, EPG (for integration of performance algorithms in its MSE hardware model), and the Signal School and Center (for consideration in initial operator training standards, SQT score requirements, and operator MOS selection strategies).

## References

- Buckalew, L. W., Smootz, E., Glaze, J. D., & Sanders, M. G. (1989). Exploratory analysis of personnel and performance: Mobile subscriber equipment follow-on operational test and evaluation. Working Paper FH 89-01, U.S. Army Research Institute, Fort Hood, TX.
- Garretson, J. F. (1988). Independent evaluation report (interim) of the mobile subscriber equipment (MSE) follow-on operational test and evaluation (FOT&E). IER-FO-1148, U.S. Army Operational Test and Evaluation Agency, Arlington, VA.
- FM 11-999E, Mobile subscriber equipment (MSE) architecture. (1987).
- Sabol, M., Chapell, L., & Meiers, C. (in preparation). Predicted decay of mobile subscriber equipment (MSE) operator skills. Research Report, U.S. Army Research Institute, Alexandria, VA.