



NRL/MR/6180--01-8581

Initial Evaluation of a Water Spray Cooling System in Flammable Liquid Storage Room Fires

J. B. HOOVER
R. S. SHEINSON

*Navy Technology Center for Safety and Survivability
Chemistry Division*

A. MARANGHIDES
B. H. BLACK

*GEO CENTERS, INC.
Lanham, MD*

September 28, 2001

Approved for public release; distribution is unlimited.

20011026 026

REPORT DOCUMENTATION PAGE

Form Approved
OMB No. 0704-0188

Public reporting burden for this collection of information is estimated to average 1 hour per response, including the time for reviewing instructions, searching existing data sources, gathering and maintaining the data needed, and completing and reviewing the collection of information. Send comments regarding this burden estimate or any other aspect of this collection of information, including suggestions for reducing this burden, to Washington Headquarters Services, Directorate for Information Operations and Reports, 1215 Jefferson Davis Highway, Suite 1204, Arlington, VA 22202-4302, and to the Office of Management and Budget, Paperwork Reduction Project (0704-0188), Washington, DC 20503.

1. AGENCY USE ONLY (<i>Leave Blank</i>)	2. REPORT DATE September 28, 2001	3. REPORT TYPE AND DATES COVERED Final report 1996-1998	
4. TITLE AND SUBTITLE Initial Evaluation of a Water Spray Cooling System in Flammable Liquid Storage Room Fires		5. FUNDING NUMBERS	
6. AUTHOR(S) J.B. Hoover, R.S. Sheinson, A. Maranghides,* and B.H. Black*			
7. PERFORMING ORGANIZATION NAME(S) AND ADDRESS(ES) Naval Research Laboratory Washington, DC 20375-5320		8. PERFORMING ORGANIZATION REPORT NUMBER NRL/MR/6180--01-8581	
9. SPONSORING/MONITORING AGENCY NAME(S) AND ADDRESS(ES) Naval Sea Systems Command 1333 Isaac Hull, Ave. SE, Washington Navy Yard Washington, DC 20376		10. SPONSORING/MONITORING AGENCY REPORT NUMBER	
11. SUPPLEMENTARY NOTES *Geo Centers, Inc., Lanham, MD 20706			
12a. DISTRIBUTION/AVAILABILITY STATEMENT Approved for public release; distribution is unlimited.		12b. DISTRIBUTION CODE	
13. ABSTRACT (<i>Maximum 200 words</i>) The US Navy has been evaluating Halon replacement agents and technologies for use onboard new construction platforms. After extensive research and development, the Navy selected HFP (heptafluoropropane, HFC-227ea, C ₃ F ₇ H) as the clean Halon replacement agent of choice. HFP, as do all other hydrofluorocarbons, provides limited compartment cooling and generates very large quantities of toxic and corrosive hydrogen fluoride (HF). The Water Spray Cooling System (WSCS), invented and patented by NRL, was designed to enhance the performance of gaseous total flooding fire suppression agents. The WSCS is a low-pressure overhead water spray system designed to operate at firemain pressure, e.g., 10.2 bar (150 psi). When used in conjunction with HFP, the WSCS expedites compartment reclamation by providing compartment cooling and significantly reducing HF. The WSCS concept was first explored on the ex-USS <i>Shadwell</i> . An evaluation of the WSCS concept was conducted as part of the Flammable Liquid Storeroom (FLSR) Halon Replacement Test Program. This report describes the initial work conducted in the 28 m ³ (1,000 ft ³) FLSR 1 test compartment. Although the number of tests WSCS conducted was limited, the results clearly demonstrated the advantages provided by the WSCS.			
14. SUBJECT TERMS Halon replacement Halon substitute Water spray cooling system WSCS		15. NUMBER OF PAGES 75	
		16. PRICE CODE	
17. SECURITY CLASSIFICATION OF REPORT UNCLASSIFIED		18. SECURITY CLASSIFICATION OF THIS PAGE UNCLASSIFIED	19. SECURITY CLASSIFICATION OF ABSTRACT UNCLASSIFIED
		20. LIMITATION OF ABSTRACT UL	

CONTENTS

1.0	INTRODUCTION.....	1
2.0	EXPERIMENT.....	2
2.1	FLSR 1 Test Compartment.....	2
2.1.1	Internal configuration.....	8
2.1.2	Ventilation system configuration.....	9
2.1.3	Fuel system configuration	12
2.1.4	Suppression system configuration.....	13
2.1.5	WSCS configuration	13
2.2	Experiment Control and Data Acquisition.....	18
2.2.1	Thermocouple trees.....	20
2.2.2	Continuous acid analyzers.....	20
2.3	Halon Replacement Test Procedures	22
2.3.1	Reignition procedures.....	24
2.4	WSCS Test Procedures.....	24
3.0	DATA ANALYSIS	25
3.1	Selection of Tests	25
3.2	Data Analysis Procedures.....	32
4.0	RESULTS	36
4.1	Group 1 - No Suppression	37
4.2	Groups 2 and 5 - Combined Suppression and WSCS.....	41
4.2.1	Effects on temperature	41
4.2.2	Effects on HF concentration.....	42
5.0	SUMMARY	42

6.0	RECOMMENDATIONS.....	47
6.1	Operational Considerations for the WSCS	47
6.2	Investigation of WSCS Thermal Effects.....	52
6.3	Investigation of WSCS HF Reduction Effects.....	53
7.0	ACKNOWLEDGMENTS.....	53
8.0	REFERENCES.....	54
APPENDIX A	Temperature Comparisons for Group 1 Tests	
APPENDIX B	Temperature and HF Comparisons for Group 2 Tests	
APPENDIX C	Temperature and HF Comparisons for Group 5 Tests	

INITIAL EVALUATION OF A WATER SPRAY COOLING SYSTEM IN FLAMMABLE LIQUID STORAGE ROOM FIRES

1.0 INTRODUCTION

The phase-out of ozone depleting chlorofluorocarbons (CFCs) and Halons has significantly restricted US Navy options for shipboard fire protection. The most obvious issue is the question of machinery space protection, which historically has been addressed with total flooding Halon 1301 systems. Due to the Montreal Protocol, those systems must be replaced, on new-design ships, with alternative systems having low, or zero, ozone depletion potential (ODP).

For several years, the Naval Research Laboratory (NRL) has been investigating possible solutions to these problems, including evaluation of new, low-ODP gaseous fire suppression agents and research into zero-ODP agents such as water mist. As part of this work, NRL has conducted extensive intermediate [1] and full-scale [2,3] tests of possible Halon 1301 replacements for shipboard machinery spaces. In those scenarios, the primary threat was a spray fire from a pressurized flammable liquid, such as diesel fuel, hydraulic fluid or lubricating oil.

In addition to machinery spaces, there are other compartments aboard Navy ships that have significant fire threats and have traditionally been protected by Halon 1301 total flooding fire suppression systems. These compartments include Flammable Liquid Storerooms (FLSRs), paint mixing and issue rooms and fuel bladder storage rooms. FLSRs have been identified as especially hazardous. This is due to the types and amounts of fuels stored and to the tight quarters and restricted accesses that are typical of these storage compartments.

FLSRs often contain a wide variety of flammable liquids, and materials which have been impregnated with such liquids, including paints, paint thinners, alcohols, solvents, various Class A materials, drop cloths, oils, paint brushes, and various acids. These materials vary widely in flammability and extinction requirements, with some being much easier to extinguish than machinery space fuels while others are significantly more difficult. Combustion of many of these materials, either alone or in conjunction with other materials, poses toxic hazards beyond those associated with ordinary Class B fires.

The shelves, fuel containers and other obstructions within FLSRs interfere with the distribution of gaseous agents and greatly exacerbate the extinguishment problem. In addition, FLSRs are normally unoccupied spaces, allowing time for smoldering fires to progress to flaming fires before detection.

Shipboard FLSRs vary in size from less than 28 m³ (1,000 ft³) on smaller ships to over 1,100 m³ (40,000 ft³) on aircraft carriers. Fuel containers range from quart size to 55 gal drums and the varieties of containers can be as diverse as the fuels. It is not unusual to find military specification fuel containers adjacent to commercial off-the-shelf containers, even including glass containers. Some of the more flammable fuels (such as alcohols) are isolated in designated flammable liquid cabinets within the FLSRs.

The NRL Halon replacement test program has included investigation of fixed fire extinguishing systems for future use against the non-pressurized liquid fuel fires typically found outside of the machinery spaces. FLSRs were chosen as the target environments for the NRL tests largely because they pose an especially difficult problem for fixed suppression systems in which the primary threat is a highly obstructed, cascading, three-dimensional flammable liquid spill fire.

To support the FLSR Halon 1301 replacement tests, two new facilities, FLSR 1 and FLSR 2, have been constructed at the NRL Chesapeake Bay Detachment (CBD). FLSR 1 has a volume of

28 m³ (1,000 ft³) and is similar to the small flammable liquid lockers found on many Navy ships. FLSR 2 has an internal volume of 297 m³ (10,500 ft³), which is representative of the storerooms on some larger ships.

At present, the US Navy's preferred gaseous replacement for Halon 1301 is heptafluoropropane (HFP). This compound, also known as C₃HF₇ or HFC-227ea, is marketed by the Great Lakes Chemical Corporation as FM-200™ and by DuPont as FE-227™. To date, the main focus of the FLSR tests has been the characterization of HFP performance in order to provide system design guidance to the Naval Sea Systems Command.

The use of gaseous agents, including Halon and HFP, is known to present several operational difficulties. Due to their low heats of vaporization and gas phase heat capacities, these agents have essentially no cooling capability. In addition, most produce high concentrations of highly toxic hydrogen fluoride (HF) gas during extinguishment. Finally, they provide limited protection against reignition during post-extinguishment ventilation. In the course of the HFP investigations, NRL developed a concept for a water-spray cooling system (WSCS) which, when used as an adjunct to an installed gaseous agent fire suppression system [4], may address these issues. Recently, a United States patent [5] has been granted for this concept.

The WSCS may contribute to suppression or extinguishment, but its primary purposes are to limit damage caused by the fire and to expedite reentry and post-fire recovery. In principle, the WSCS can cool the fire compartment, reduce the production of HF, increase the rate of removal of soot and toxic gases and increase reignition protection during the ventilation period.

Only a small amount of the work conducted during the HFP research program addressed the WSCS concept itself. However, even that limited testing was sufficient to validate the basic concept and to identify the critical parameters that must be investigated as part of a future full-scale development program. This report is intended to document these proof-of-concept tests and to outline the engineering work which remains to be done to support design of an actual shipboard WSCS. We will discuss the effects of WSCS on temperature reduction and HF mitigation. The experiments described were conducted between March 1997 and October 1997 in the FLSR 1 facility.

2.0 EXPERIMENT

FLSR 1 was designed to simulate a small, shipboard flammable liquid storeroom. To that end, it was built with materials and fittings typical of those actually found on Navy ships and then equipped with the special capabilities needed to safely conduct full-scale fire tests.

Three categories of tests were conducted as part of this program. The baseline tests involved either a cascade or a combined cascade and pan fire with no suppression and no water spray cooling. In the suppression tests, an extinguishing agent (either Halon 1301 or HFP) was added to the baseline scenario. Finally, some tests involved the use of a prototype WSCS to mitigate the effects of the fire. WSCS tests were carried out both with and without the use of an extinguishing agent.

2.1 FLSR 1 Test Compartment

For orientation, Figures 1 - 4 show exterior views of FLSR 1 from aft, port, forward and starboard, respectively. The compartment is 3.03 m (9.94 ft) x 3.03 m (9.94 ft) x 2.95 m (9.68 ft) high. The standard Navy watertight door in the center of the aft bulkhead provides the only access to the compartment. Part of the ventilation system is shown to the left of center in Figure 2, with a manifold for gas sampling to the right of the vent duct. Various power and data lines

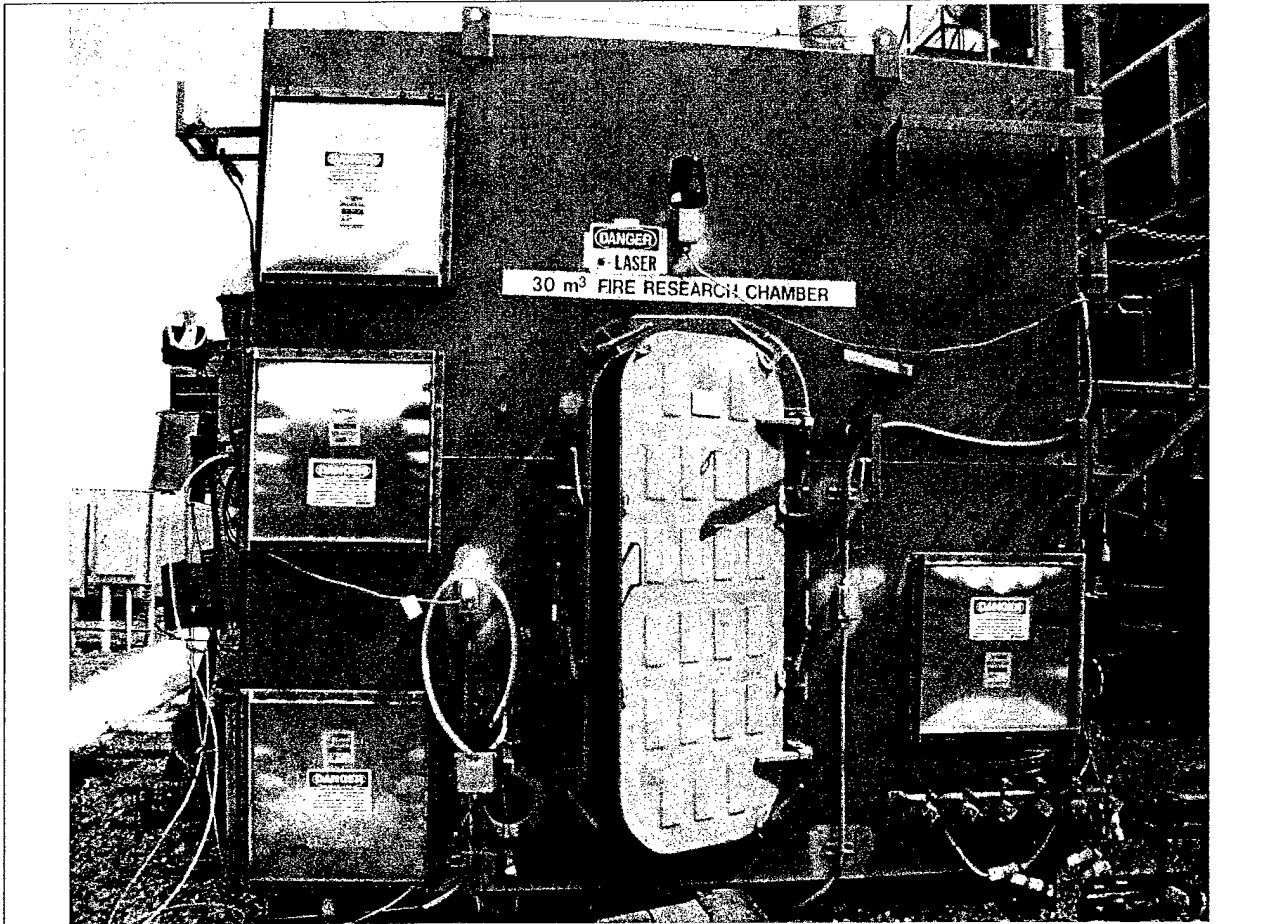

Figure 1. Aft View of FLSR 1

This watertight door in the center of the aft bulkhead provides the only access to FLSR 1. The silver squares with the warning labels are pressure relief panels that prevent dangerous over pressurization of the chamber.

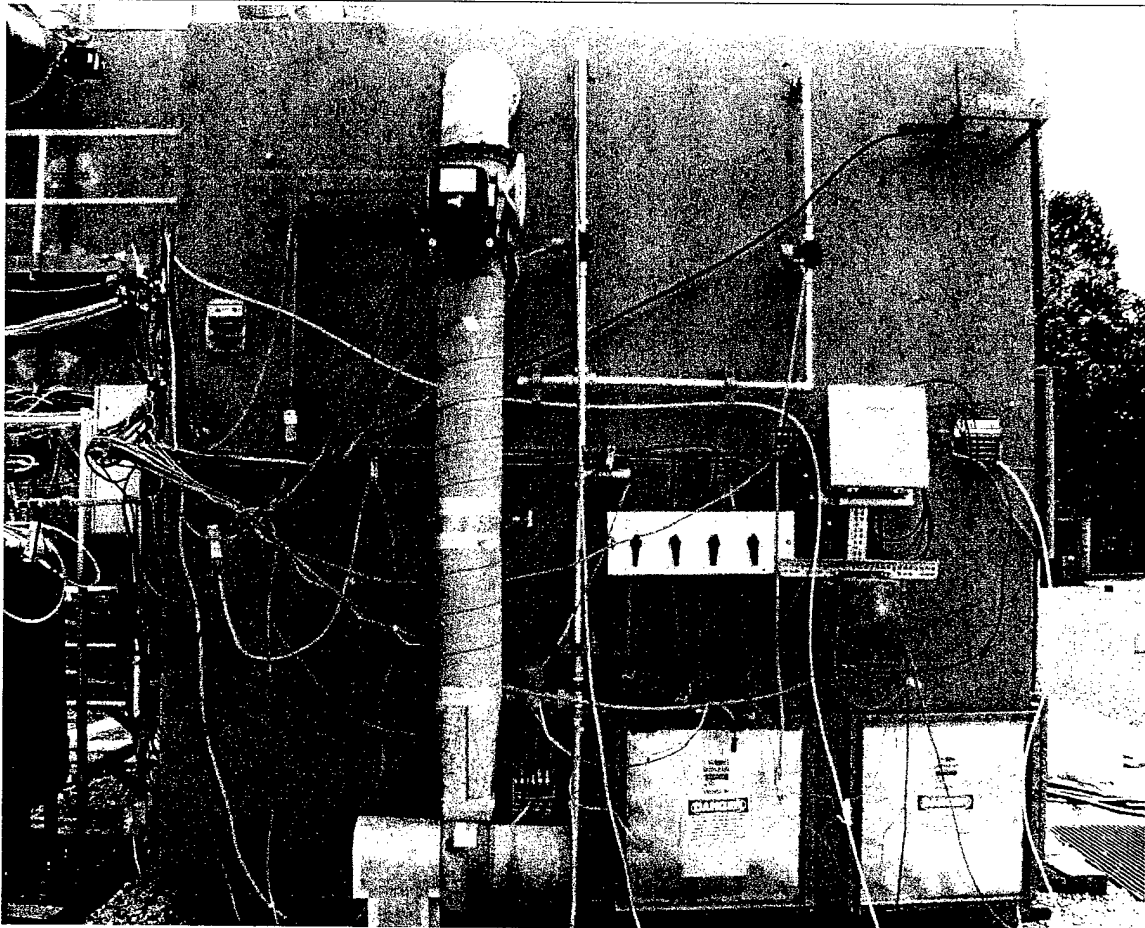

Figure 2. Port View of FLSR 1

The vertical duct to the left of center is part of the ventilation supply system, with the blower and motor at the bottom. The panel to the right at mid-height is a gas sampling manifold. The silver squares with the warning labels are pressure relief panels, which prevent dangerous over pressurization of the chamber.

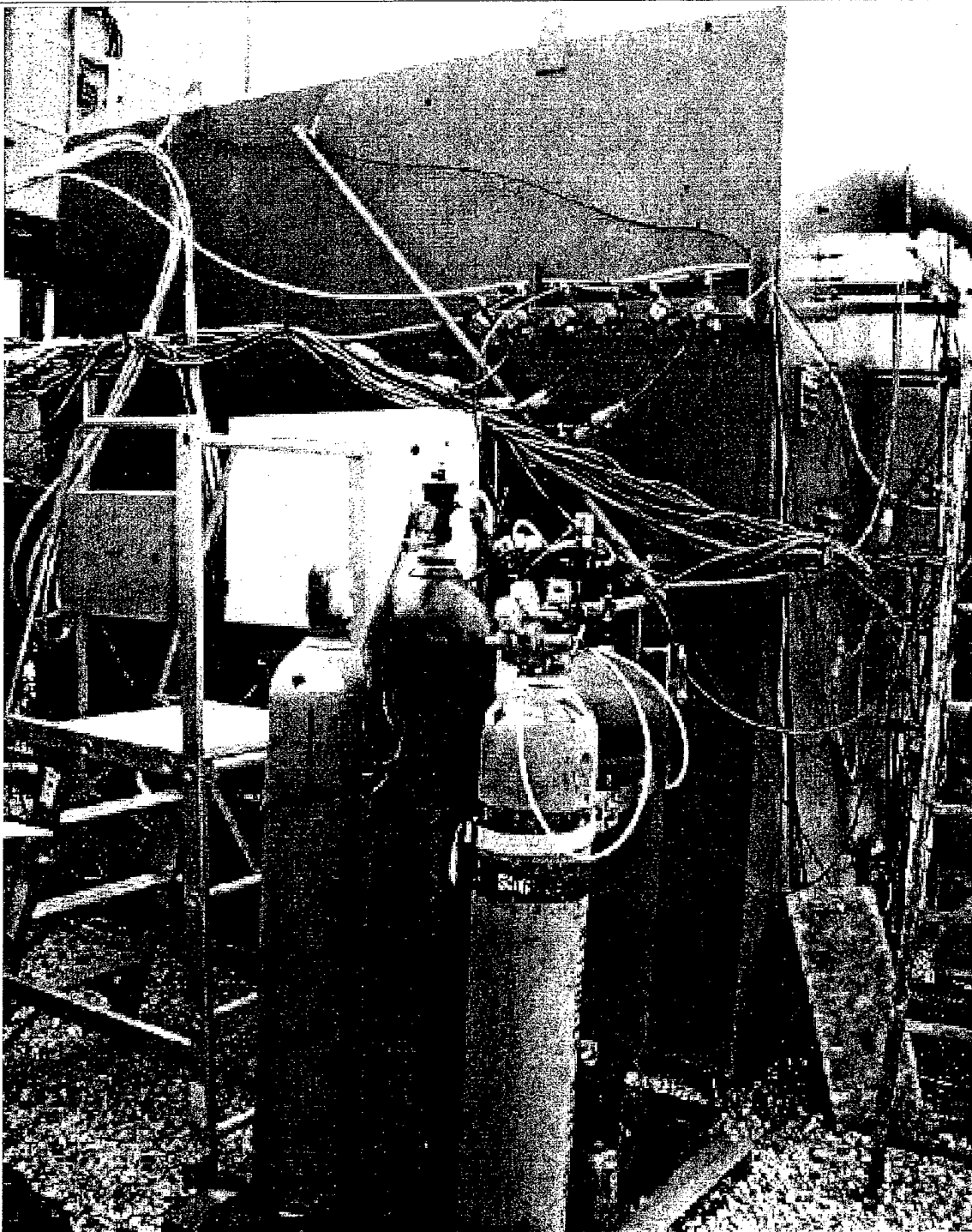

Figure 3. Forward View of FLSR 1

The cable bundles on the left and running diagonally to the right include power for various instruments and control relays and signal lines back to the data acquisition and experiment control system. The cylinders in the foreground were not used in these Halon Replacement test series.

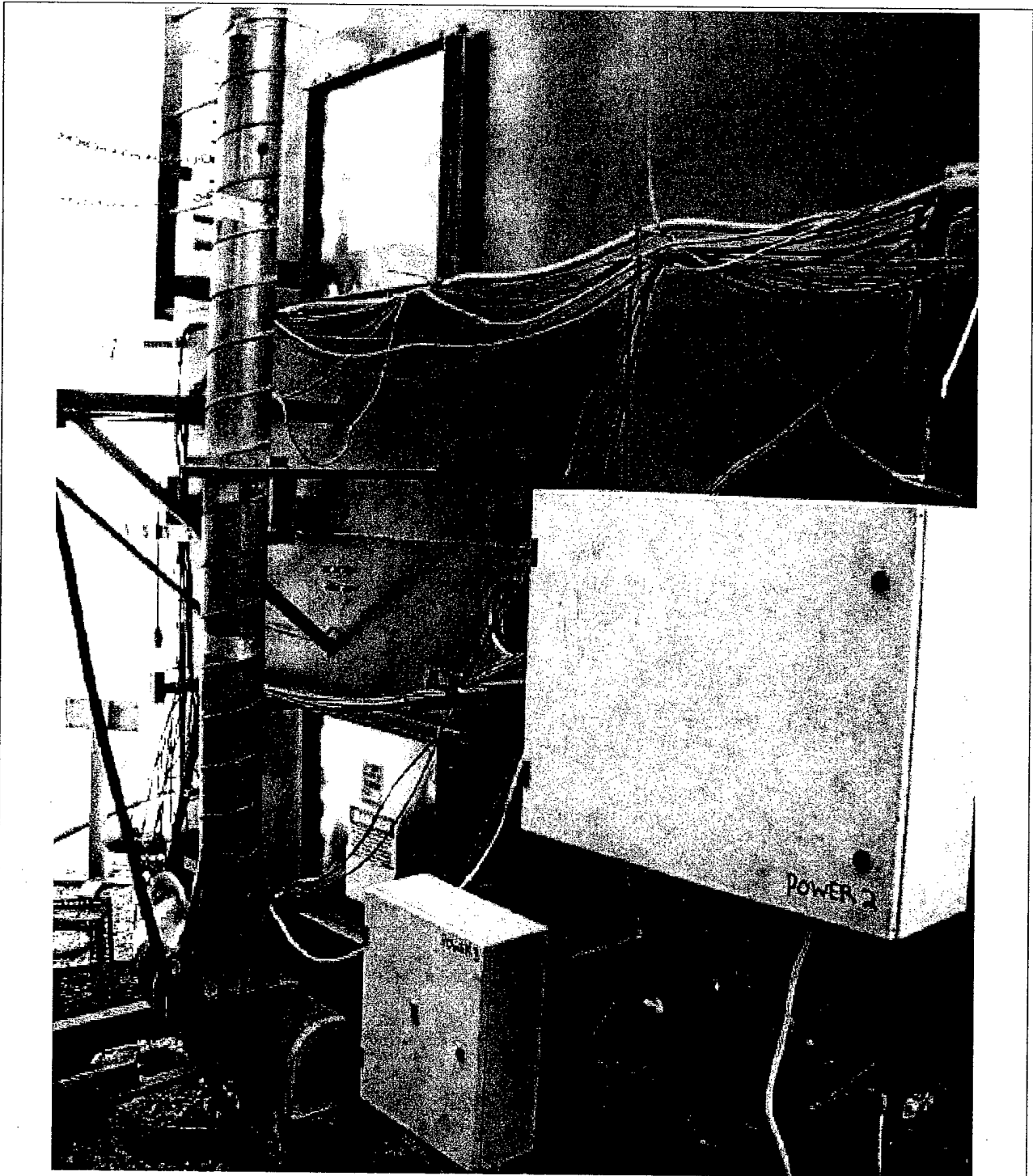

Figure 4. Starboard View of FLSR 1

The ventilation exhaust blower and motor are in the lower left portion of this photograph, with the vent duct extending vertically out of the picture. The silver squares behind the exhaust stack are pressure relief panels.

are visible in the forward view. The silver squares in Figures 1, 2 and 4 are pressure relief panels that rupture in the event of compartment over-pressurization to limit compartment damage. They are designed to deploy at two-psi overpressure.

Figure 5 is a mechanical drawing that illustrates the construction of FLSR 1. The internal stiffeners (frames) shown in that drawing are "T" beams, 13 cm (5.25 in.) wide, providing a 10 cm (4 in.) standoff from the bulkhead and having a nominal spacing of 0.75 m (2.46 ft). These frames are important because they enforce the standoff distance between the bulkheads and internal fittings, such as shelves, providing a path for vertical flame and smoke spread within the compartment. For clarity, the stiffeners are not shown in subsequent drawings.

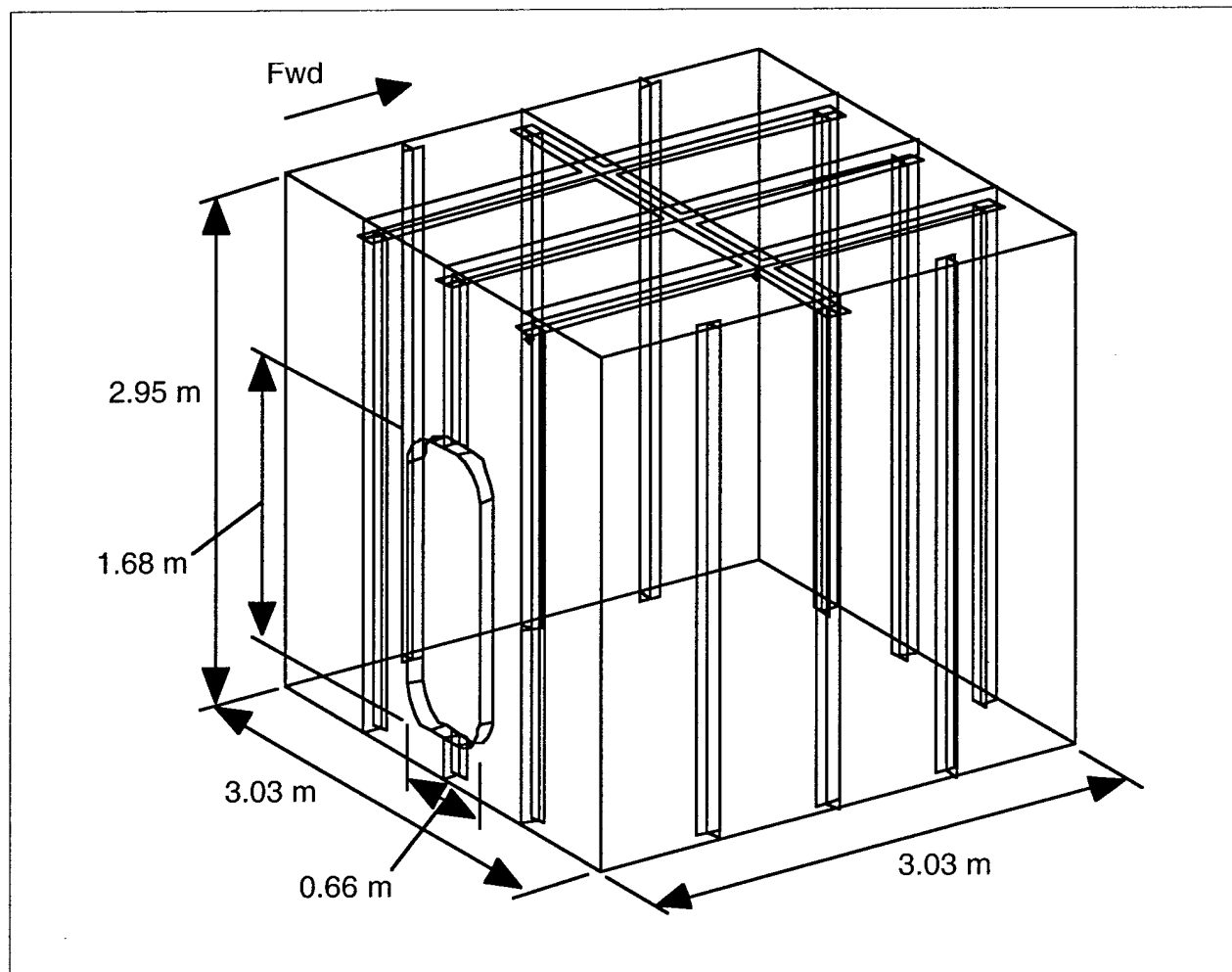

Figure 5. FLSR 1 Compartment Structure

CAD drawing of the FLSR 1 structure, including frame members. The compartment is nearly cubic, with dimensions of 2.95 m (9.67 ft) H x 3.03 m (9.94 ft) W x 3.03 m (9.94 ft) D. The watertight hatch is 1.68 m (5.50 ft) x 0.66 m (2.17 ft). The frames are steel "T" girders and are 10.2 cm (4 in.) deep with a 0.76 m (2.48 ft.) nominal spacing.

In the following two sections, we discuss the FLSR 1 as it was configured for the Halon replacement test program. This includes details about the compartment itself and the installed suppression and ventilation systems and concludes with a description of the modifications made to support the WSCS demonstration.

2.1.1 Internal configuration

Details of the storage shelves are shown in Figure 6. There are two banks, along the forward and port bulkheads, with four shelves per bank. Each shelf was constructed with a 2.15 m (7.05 ft) long x 0.65 m (2.15 ft) wide x 4 cm (1.6 in.) deep frame that held a steel plate. The vertical spacing between frames was 0.61 m (2.0 ft).

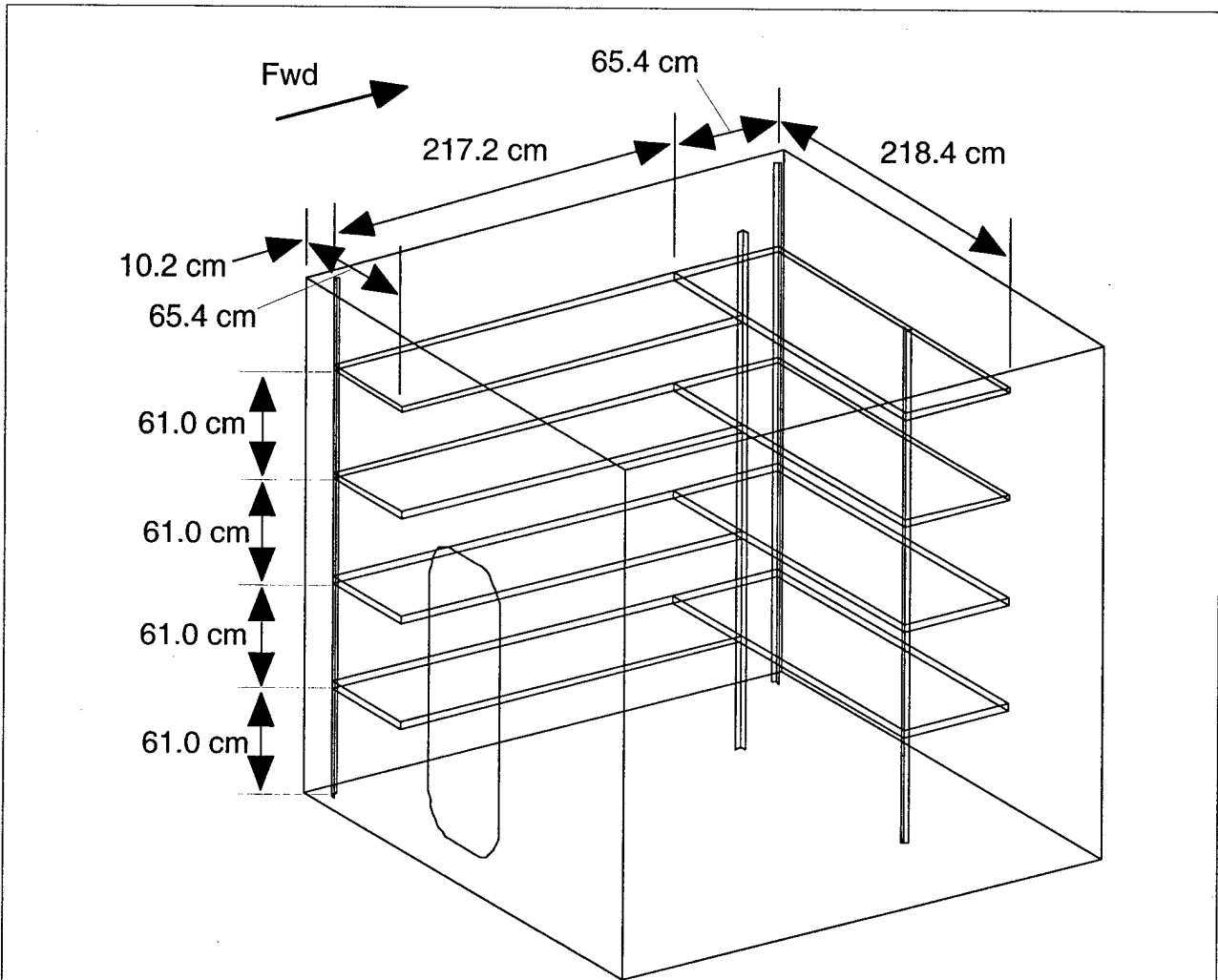

Figure 6. FLSR 1 Storage Shelves

This CAD drawing shows the location of the installed shelves. For clarity, the internal stiffeners have not been shown. The shelves are nominally 218 cm (86 in.) long by 65.4 cm (25.75 in.) deep and are offset from the forward, port and aft bulkheads by 10.2 cm (4.0 in.), due to the presence of the frames. The shelf-to-shelf spacing is 61 cm (24.0 in.).

Both solid and perforated plates were available to simulate the different kinds of shelving found aboard ships but the vast majority (92%) of the tests, including all those discussed in this report, used the perforated type. These plates had a 10 x 12 array of 1.90 cm (0.75 in.) holes on 6.35 cm (2.5 in.) centers. An example of this material is shown in Figure 7. 19 l (five gallon) containers,

similar to those used for many flammable liquids aboard ships, are also visible in this photograph.

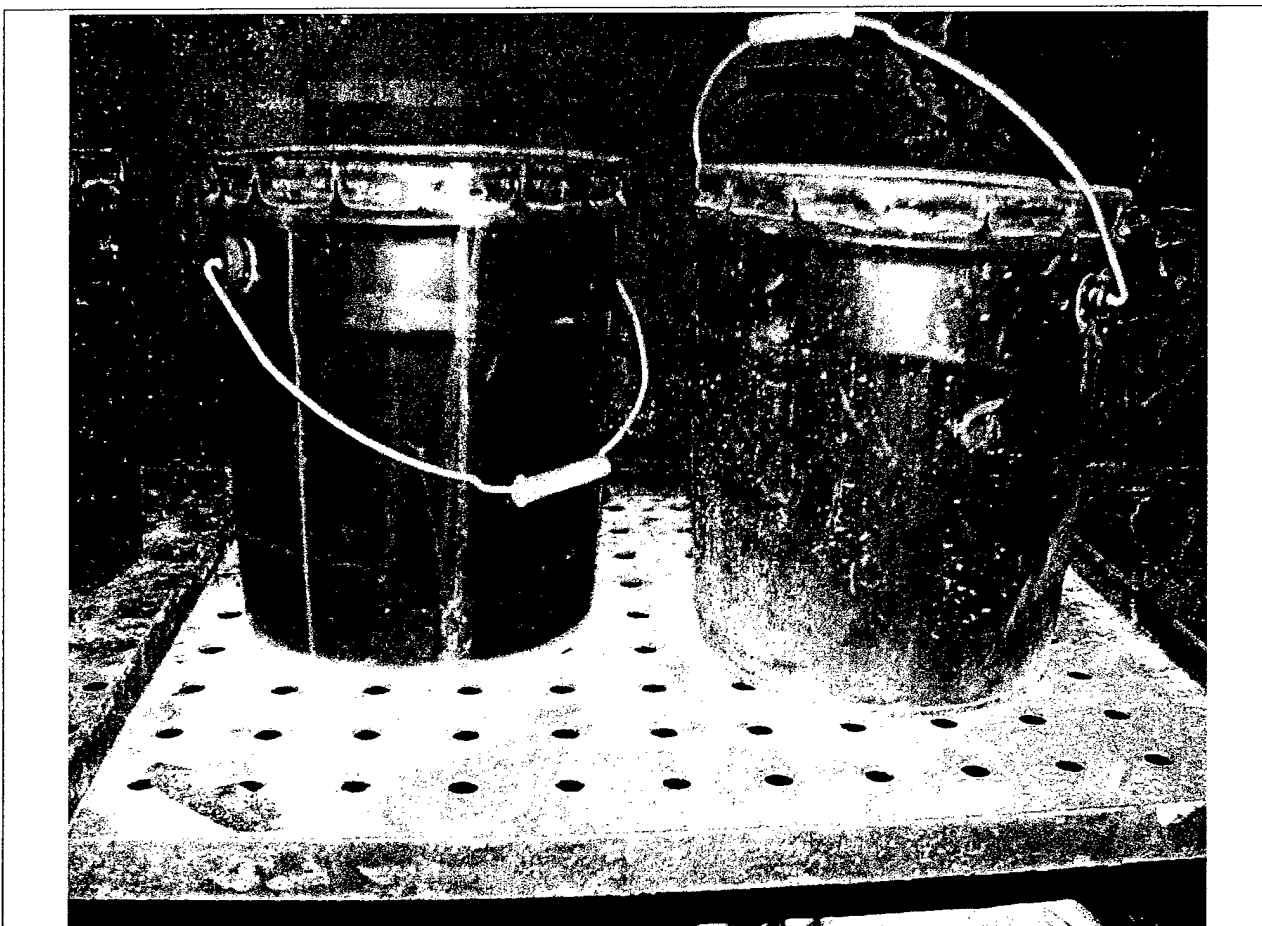

Figure 7. FLSR 1 Storage Shelves

Perforated shelves in FLSR 1, with typical obstructions [19 l (five-gallon containers)].

The ventilation system was configured to provide one complete air exchange every four minutes using a balanced $7 \text{ m}^3/\text{min}$ (247 cfm) supply and exhaust.

2.1.2 Ventilation system configuration

The ventilation system consisted of two primary components, a supply manifold and an exhaust manifold. With the exception of the inlet vent and a short stub of ductwork, the entire supply system was located outside the compartment and is visible in Figure 2. The exhaust system included two vents inside the compartment with the blower and exhaust stack outside the compartment on the starboard side (see Figure 4).

The inlet duct was high on the port bulkhead, slightly forward of the compartment midline. One of the outlet vents was at a comparable height, on the starboard side aft of the midline while the second was low in the starboard, aft corner. The exhaust duct penetrated the bulkhead directly behind the second vent. Figure 8 is a schematic of the interior components of the ventilation system while Figure 9 shows the arrangement of the exhaust system.

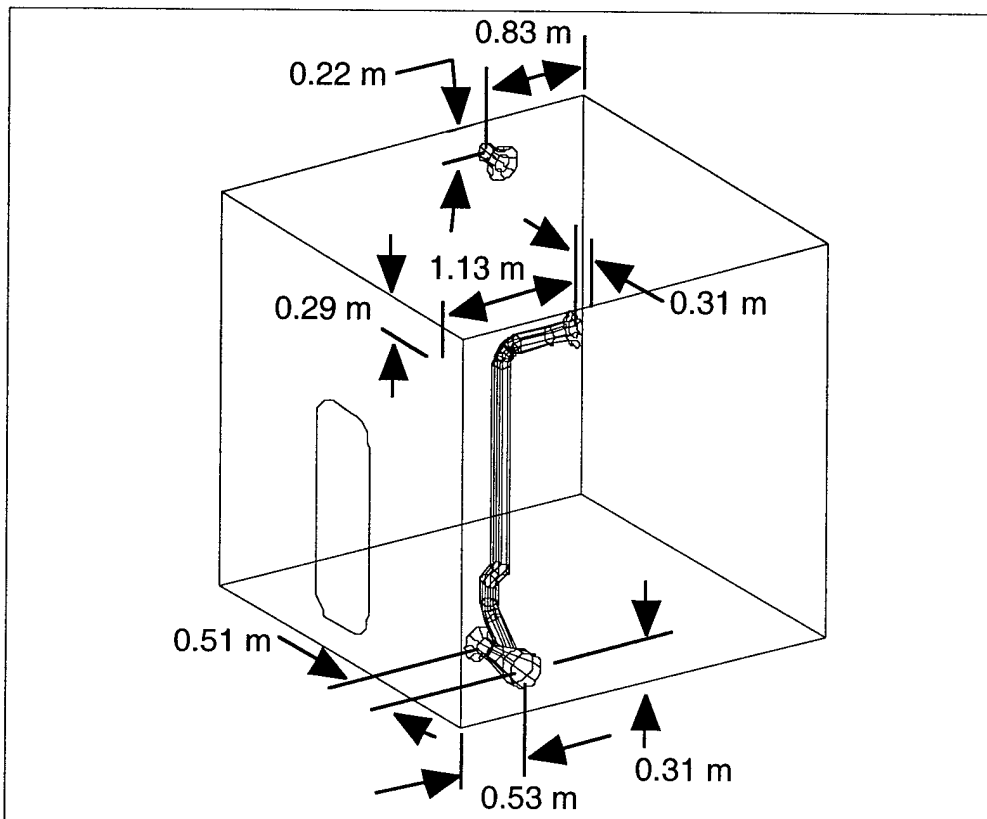

Figure 8. Ventilation System Schematic

As shown in this CAD drawing, the FLSR 1 ventilation system has two components: a supply duct high on the port bulkhead and an exhaust manifold on the starboard side. The latter includes one inlet near the deck and a second close to the overhead, as is typical of shipboard FLSRs of this size. For clarity, the internal stiffeners have not been shown.

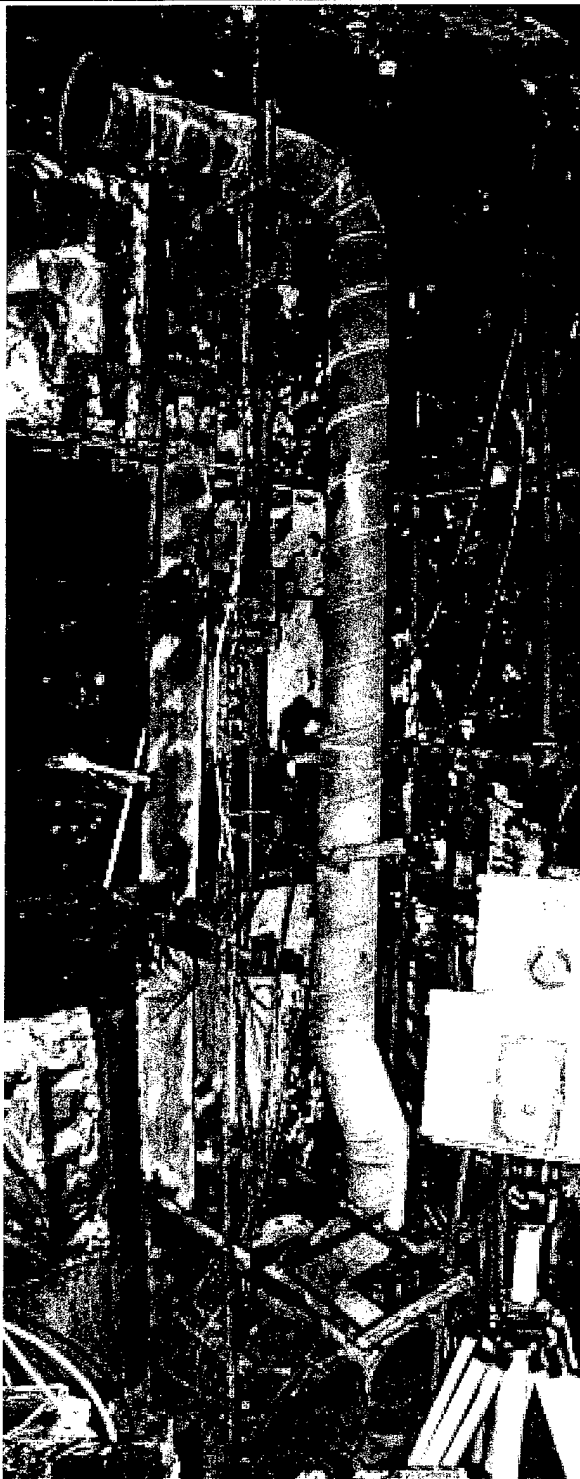

Figure 9. Interior Ventilation Exhaust Manifold

The exhaust vents were located on the starboard side of the compartment. One vent was near the deck in the aft corner and the second was high and somewhat further forward.

The nominal ventilation activation time for the tests discussed in this report was 900 seconds after agent discharge. However, the actual blower startup was delayed by 30 seconds to permit the dampers to fully open. An interlock switch enforced this delay.

2.1.3 Fuel system configuration

Initial FLSR 1 tests were conducted with only a cascading fire, which was fed, via a copper pipe, from a 19 l (five gallon) reservoir located outside of the compartment. The fuel used was 80% methanol (MeOH), sweetened with 20% n-heptane to enhance flame visibility and to simulate a multicomponent fuel spill, as might occur in an actual FLSR. Methanol was selected because the high HFP concentration required for extinguishment makes it a worst-case test for possible Halon replacements.

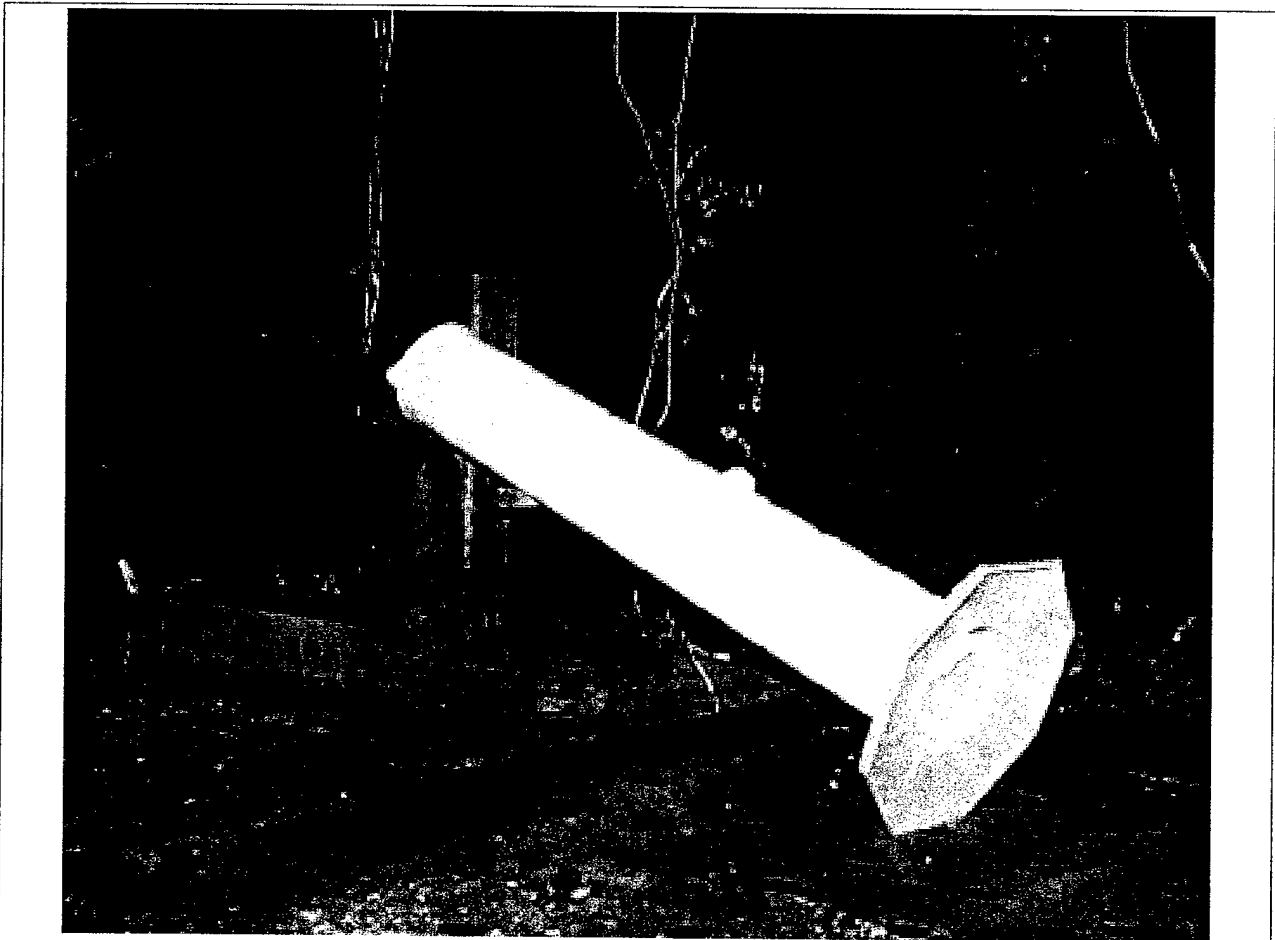

Figure 10. FLSR 1 Fuel Feed Calibration

The cascade fuel feed was calibrated by capturing fuel in a graduated cylinder over a measured time period. Fuel entered [from a 19-l (5-gallon) reservoir located outside of the compartment] via the metal tube visible on the left. During the tests, the fuel dripped onto the shelf, cascaded to lower shelves and, eventually, to the deck. This fuel feed was located at the 1.2-m (3.9-ft) level; there was a similar inlet at 2.4 m (7.9 ft).

The fuel flow rates were controlled by a metering valve and a solenoid valve in series. The metering valve was preset to the desired flow rate prior to each experiment and the flow was then

turned on and off with the solenoid valve which was triggered by the test control computer. For the tests considered in this report, the nominal fuel flow rate was either 0.012 l/sec (0.2 gpm) or 0.025 l/sec (0.4 gpm).

The fuel outlet pipe was located within the shelving at the forward port corner of the compartment at either 2.4 m (8 ft) or 1.2 m (4 ft) above the deck (Figure 10). Those locations were chosen in order to simulate leaking fuel containers in the midst of other containers on the shelves.

Several different pre-burn periods¹, ranging from 60 to 300 seconds, were used during these tests, but all of the tests considered in this study had a 120-second pre-burn. Agent discharge occurred at the end of this period and the fuel cascade was shut off automatically, usually 30 seconds after the gaseous agent discharge. The relative timing was the same in those baseline cases in which no agent was actually used.

Since the extinction characteristics of pool fires differ from those of cascade fires, it was desirable to ensure that pool fires were included in the test series. For the larger of the two flow rates, enough fuel reached the deck to produce a natural pool fire but, for the smaller flow rate, this was not always the case. Therefore, in order to ensure that there would be a pool fire, a 0.093 m² (1 ft²) pan was placed on the deck below the cascade in some tests. The pan was loaded with the same MeOH/heptane mixture that supplied the cascade and the volume of fuel in the pan was sufficient to guarantee that fuel remained after the cascade source had been shut off. This pool fire continued to burn until extinguished.

2.1.4 Suppression system configuration

The gaseous agent suppression system, illustrated in Figure 11, included agent cylinders connected via check valves to a single nozzle located in the center of the compartment overhead. A close-up of the nozzle used in these tests is shown in Figure 12. In all of the tests discussed in this report, the extinguishing agent was HFP.

2.1.5 WSCS configuration

Two WSCS configurations were designed, one with a single application nozzle and one having a dual-nozzle manifold. However, we will only discuss the single-nozzle system because it was the only one used in these tests.

As shown in Figure 13, the WSCS nozzle was located almost in the center of the compartment, 25.4 cm (10 in.) below the overhead. This placed it 15 cm (6 in.) below than the supporting frame members. Plumbing for the WSCS was 2.54 cm (1 in.) OD steel pipe. Based on prior testing aboard ex-USS SHADWELL [3], Bete TF10FC series nozzles were chosen for the experiments discussed in this report. This nozzle, shown in Figure 14, produces a 120-degree solid conical spray pattern.

The WSCS water supply was a 75 l (20 gallon) tank, located adjacent to FLSR 1 (see Figure 3), which was pressurized with nitrogen. Flow rates were controlled by adjusting the pressurization of the water supply. For most of these tests, the flow rate was nominally 0.29 l/sec (4.6 gpm); in one, the rate was 0.18 l/sec (2.9 gpm).

¹ The pre-burn period refers to the time that the fire was permitted to burn before any extinguishment attempt was made. This simulated the time that a fire might burn prior to detection plus the time required to evacuate and secure the space before the total flooding system could be discharged.

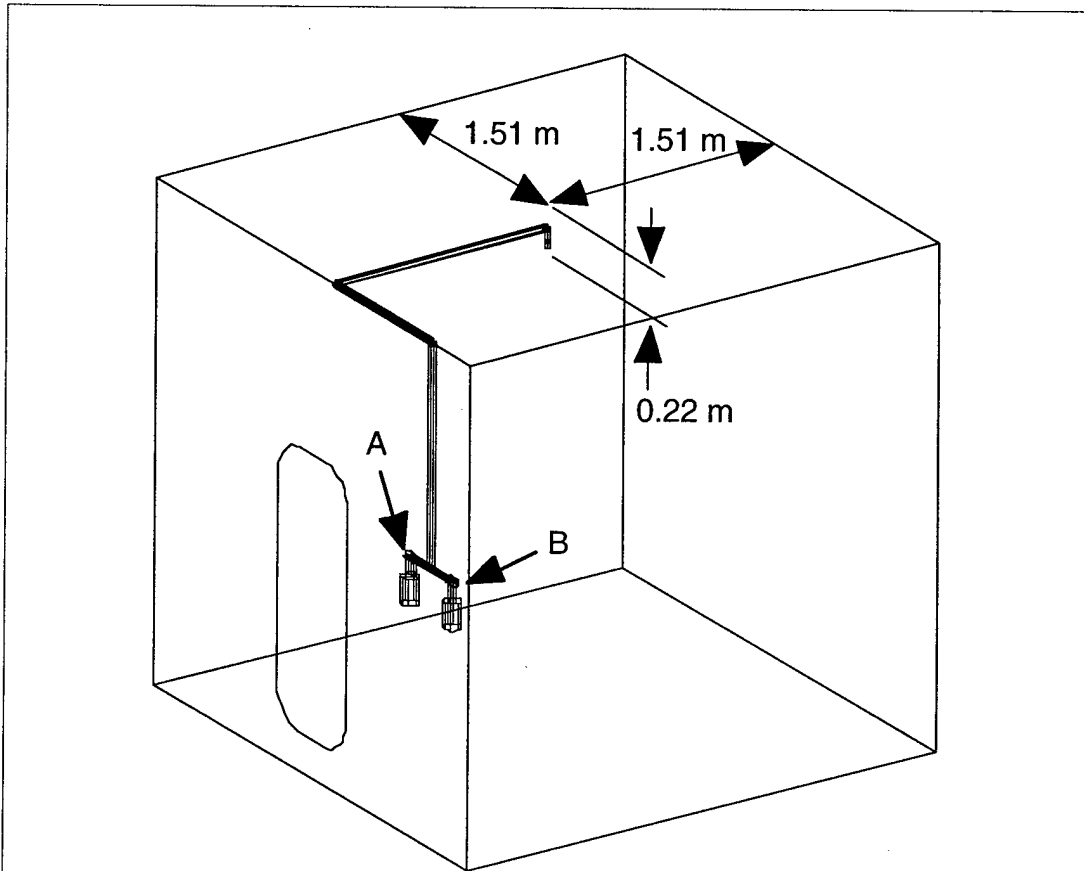

Figure 11. FLSR 1 Gaseous Suppression Agent Distribution System Schematic

CAD drawing of the agent distribution system used during these tests. The nozzle was located 22 cm (8.7 in.) below the center of the overhead. The manifold (lower center) permitted connection of either one or two agent cylinders and included check valves to prevent back flow when only one cylinder was used. Two additional branches of the system (connected at A and B) were not used for the work reported here and are not shown. For clarity, the internal stiffeners have not been shown.

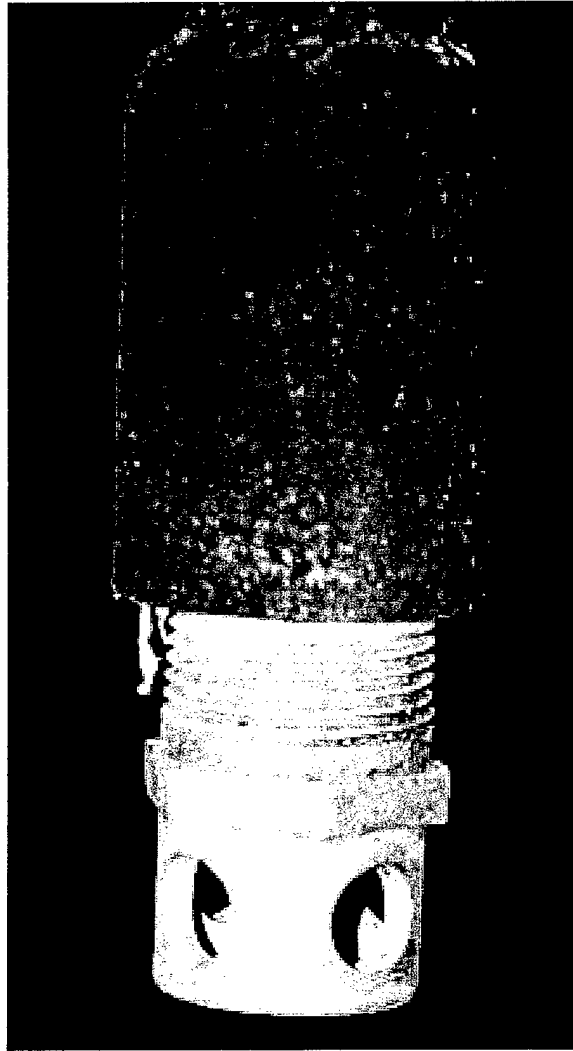

Figure 12. Agent Discharge Nozzle

Photograph of a typical Navy HFP/Halon 1301 discharge nozzle, showing the horizontal, four-hole design. The tests discussed in this report used 1.27 cm (0.5 in.) holes.

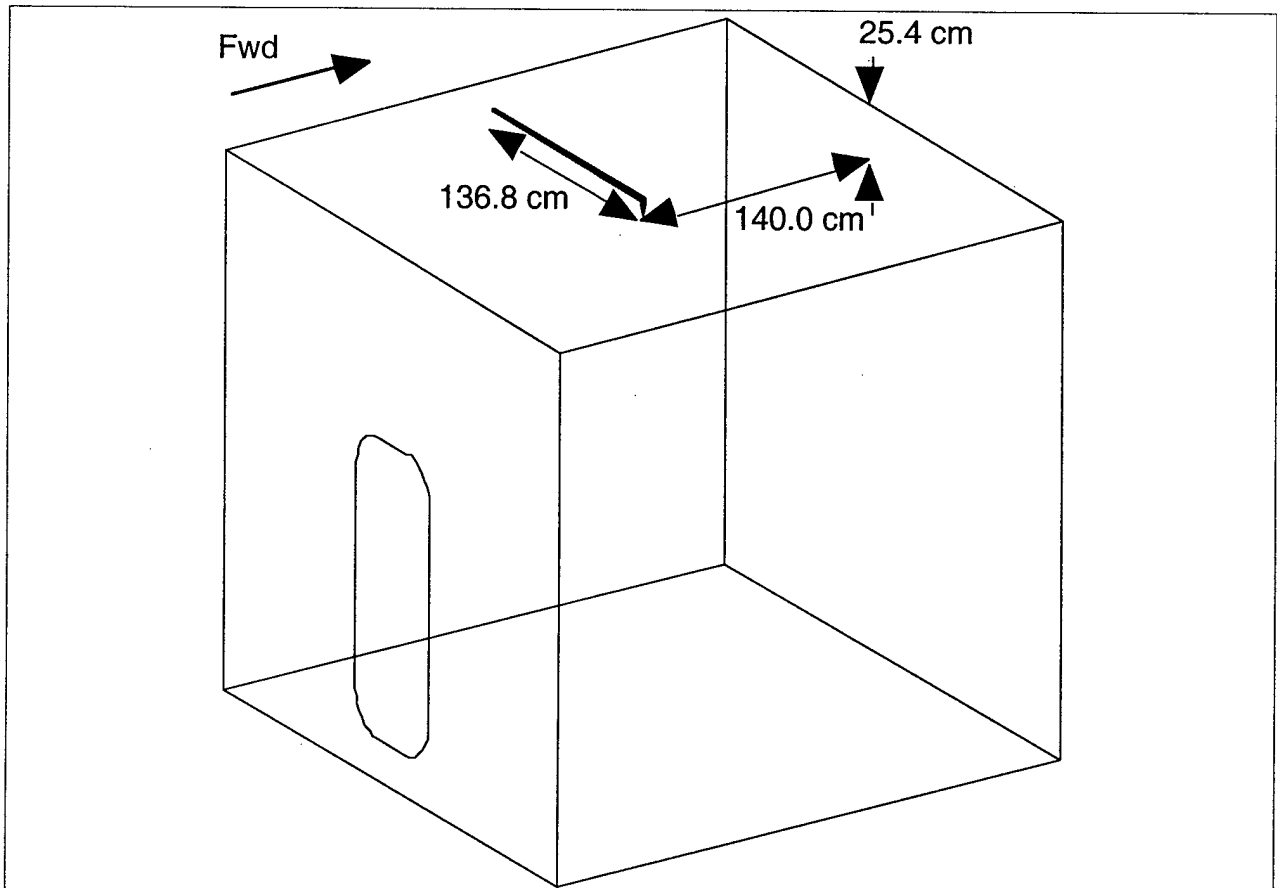

Figure 13. FLSR 1 Water Spray Cooling System Schematic

The single-nozzle water spray system is shown in this CAD drawing. The pipe [nominal 2.54 cm (1 in.) OD] penetrated the port bulkhead just below the stiffeners. The nozzle, attached via a 90° elbow, was 25.4 cm (10 in.) below the overhead. For clarity, the internal stiffeners have not been shown.

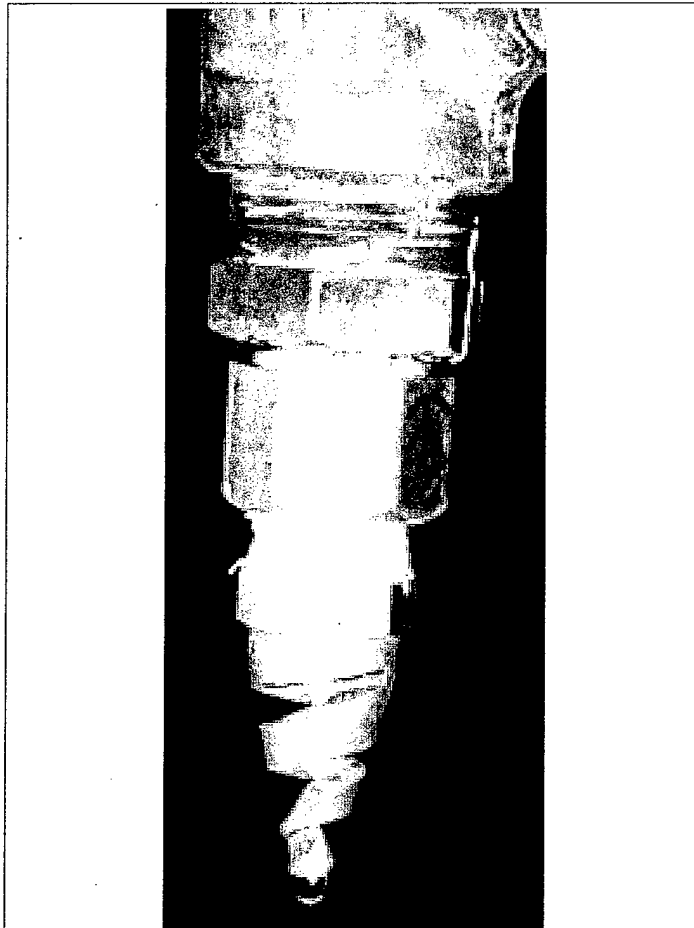

Figure 14. Water Spray Cooling System Discharge
Nozzle

Photo of the Betz TF10FC nozzle used for the WSCS. This nozzle produces a 120° solid cone spray pattern.

2.2 Experiment Control and Data Acquisition

The experiment control and data acquisition systems were housed in the Mobile Control Room (MCR), shown in Figure 15, which was located adjacent to the test chamber. Cables carrying low voltage signals ran from the MCR to a power shed where they controlled relays that provided high voltage switching for pumps, blowers and other equipment. This indirect arrangement helped to isolate the sensitive data systems in the MCR from noisy control circuits.

The fuel flow rates were controlled by a metering valve and a solenoid valve in series. The metering valve was preset to the desired flow rate prior to each experiment and the flow was then turned on and off with the solenoid valve which was triggered by the test control computer. For the tests considered in this report, the nominal fuel flow rate was either 0.012 l/sec (0.2 gpm) or 0.025 l/sec (0.4 gpm).

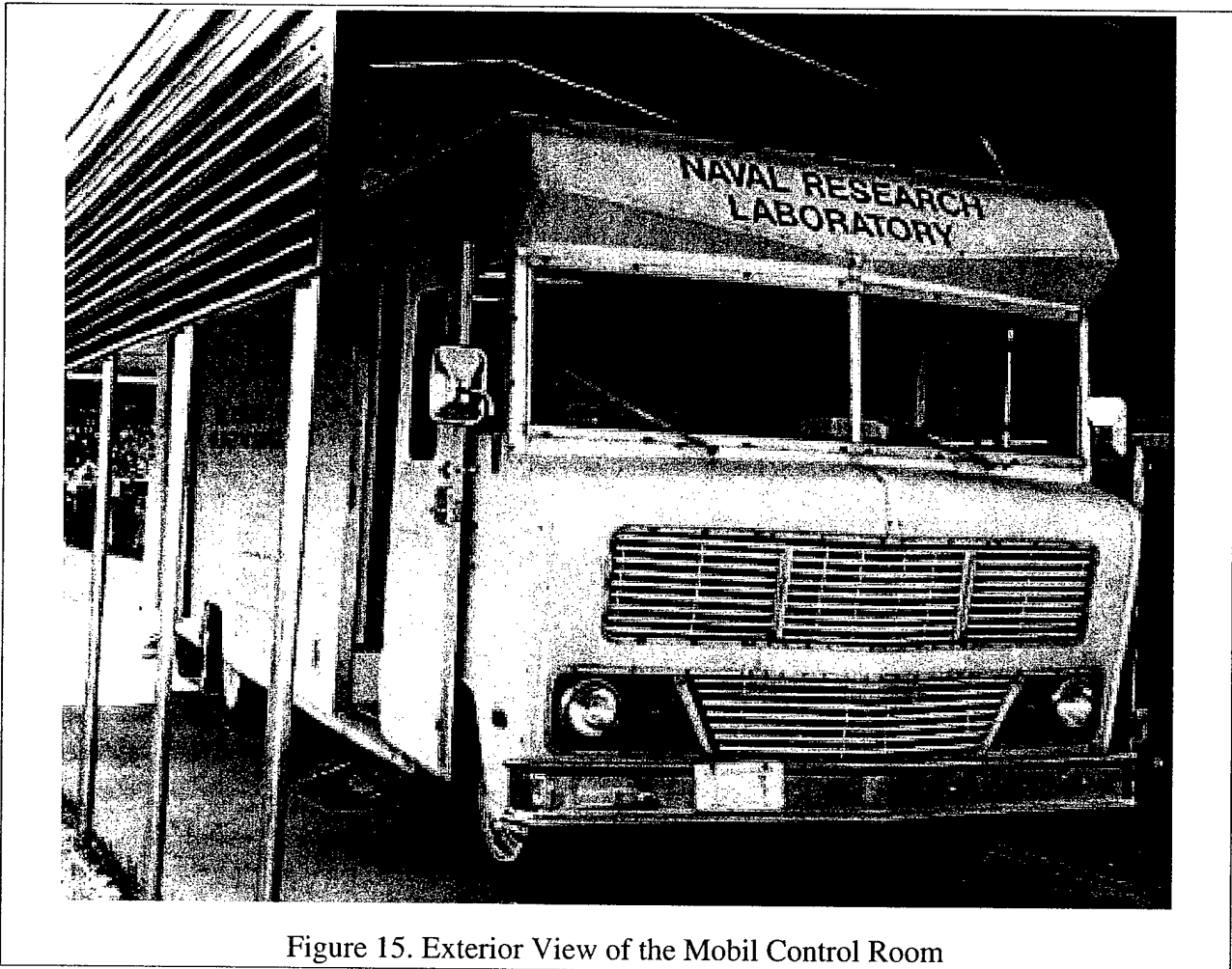

Figure 15. Exterior View of the Mobil Control Room

For some instruments, such as thermocouples, signal cables ran directly from the sensors in FLSR 1 to the data acquisition system in the MCR. For other systems [the continuous acid analyzers (CAAs), for example], the instrument was located close to, or even within, FLSR 1 and only the amplified output signal was transmitted back to the data acquisition system.

Experiment control and data acquisition for FLSR 1 was provided by the Experiment Running Personal Computer (ERPC), shown in Figure 16. ERPC was a Windows-based, 150 MHz

Pentium system running custom control and data acquisition software. This software was developed for the National Instruments LabVIEW environment and the interface to the control and acquisition hardware was via National Instruments input/output modules.

The ERPC provided timing control for all major experiment events, including initiating and securing the fuel flow, fire ignition, ventilation control and triggering of the agent and water cooling systems. It also collected over 350 channels of test data at rates of 1 Hz to 100 Hz, depending on the capabilities of the sensor.

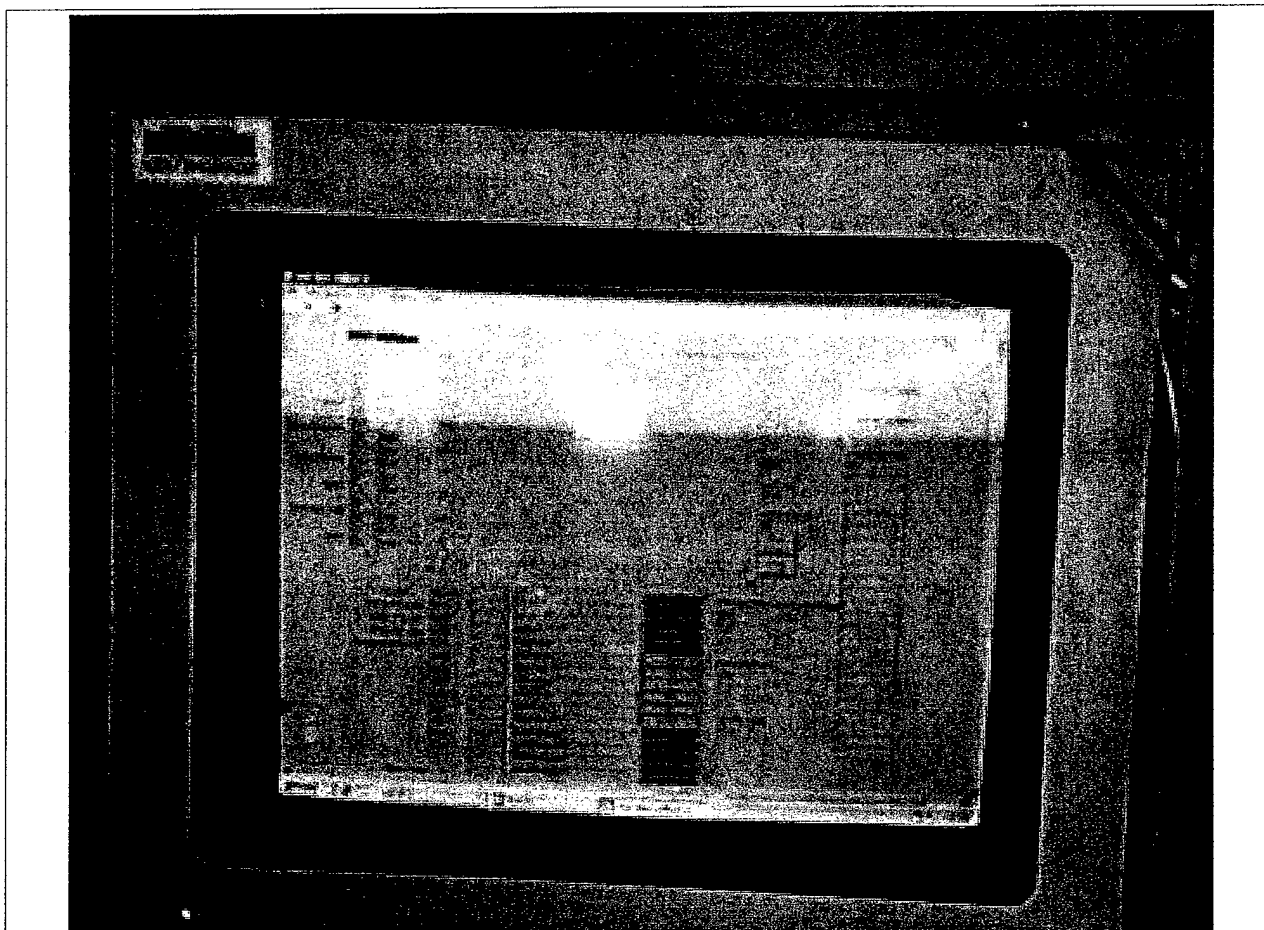

Figure 16. Experiment Running Personal Computer

The Experiment Running Personal Computer (ERPC) used this LabVIEW screen for experiment configuration. Once the test was started, the computer controlled the event sequence and collected data from the various instruments.

Test instrumentation included:

- a. thermocouples to measure air and surface temperatures within FLSR 1;
- b. CAAs to obtain continuous readings of halide acid gas production;
- c. continuous infrared (CO_2 and CO) and paramagnetic (O_2) analyzers to determine concentration at four locations;

- d. grab sample bottles at nine locations to collect agent and acid gas samples for post-test analysis;
- e. thermocouples to measure temperature at agent and acid gas grab locations at the time the sample was taken;
- f. Fourier Transform Infrared (FTIR) analyzers;
- g. compartment pressure transducers;
- h. pressure and temperature probes to monitor the agent discharge system;
- i. zirconium oxide oxygen mole fraction analyzer;
- j. compartment relative humidity probe;
- k. optical density meters to measure soot concentration at four levels; and
- l. four video cameras (two visible, two infrared) to monitor and record the fire, fire suppression, agent discharge, and fire reignition.

For the purposes of the current work, the instruments of primary interest were the four thermocouple trees and the CAAs, which are described in more detail below. These instruments were sampled at a 2 Hz rate.

2.2.1 Thermocouple trees

As shown in Figure 17, there were four thermocouple trees, each including seven type K thermocouples, located near the four corners of FLSR 1. The trees were made of steel chains, weighted to hang vertically from the overhead, with thermocouple wire laced through the chain links. This configuration keeps the individual thermocouples in relatively reproducible locations while allowing the trees to be easily pushed aside during pre-test setup and post-test cleanup.

In each tree, the thermocouples were spaced at 38-cm (15-in.) intervals, with the lowest 38 cm (15 in.) above the deck. This placed the uppermost thermocouple at an elevation of 2.7 m (8.75 ft), or 28 cm (11 in.) below the overhead.

Tree 1, near the forward, port corner, was located adjacent to the fire and behind the shelves. Because of this location, it was considered to be characteristic of the fire plume conditions, but not of the overall compartment air temperatures. Trees 2 and 4 were adjacent to the shelves and, therefore, may have been influenced by flow disturbances caused by the presence of the shelves. Accordingly, tree 3 was probably the most representative of "typical" conditions within the compartment. However, there were large spatial and temporal inhomogeneities in these experiments so the accuracy of the absolute temperatures should not be overestimated.

2.2.2 Continuous acid analyzers

In the CAAs, an air stream from the sample location is directed against a continuous impinger that extracts gaseous and aerosol halogen acids (HF, HCl and HBr) into an aqueous solution. Acid concentrations are then measured using ion specific electrodes. In these experiments, the only source of acid byproducts was the extinguishing agent, HFP, so the only acid species produced was HF.

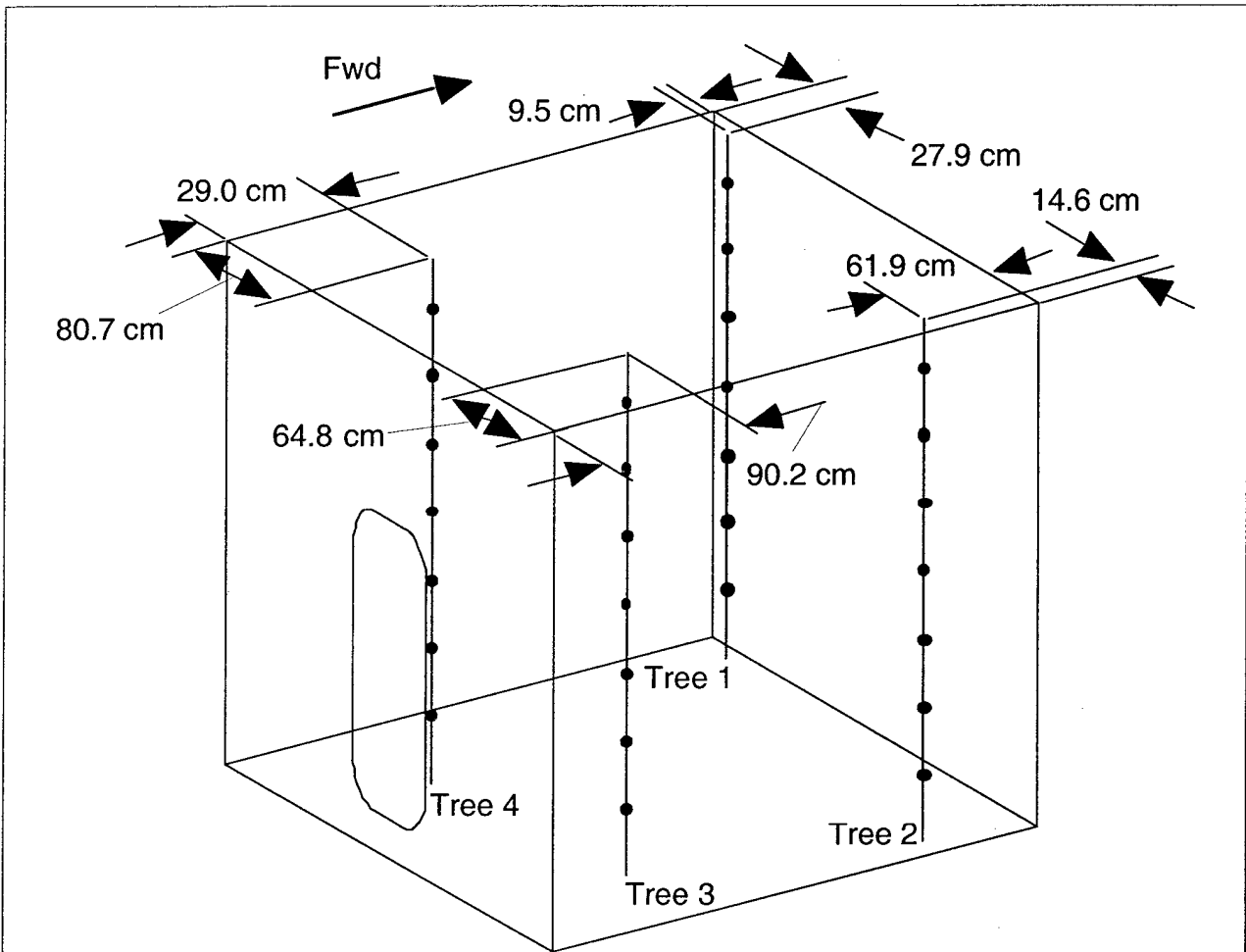

Figure 17. Thermocouple Tree Locations

Locations of the four thermocouple trees are shown, with circles indicating the position of each thermocouple. For all four trees, thermocouples were spaced at intervals of 38 cm (15 in.), starting 38 cm (15 in.) above the deck. For clarity, the internal stiffeners have not been shown.

Six CAA systems were used, as shown in Figure 18. One of these was actually within FLSR 1 and the inlet was adjacent to the FTIR to provide a crosscheck between these two types of instruments. Four CAA units were installed outside of the chamber and had short sample probes which penetrated the bulkheads. The sixth sampled the external exhaust stack (see Figure 5).

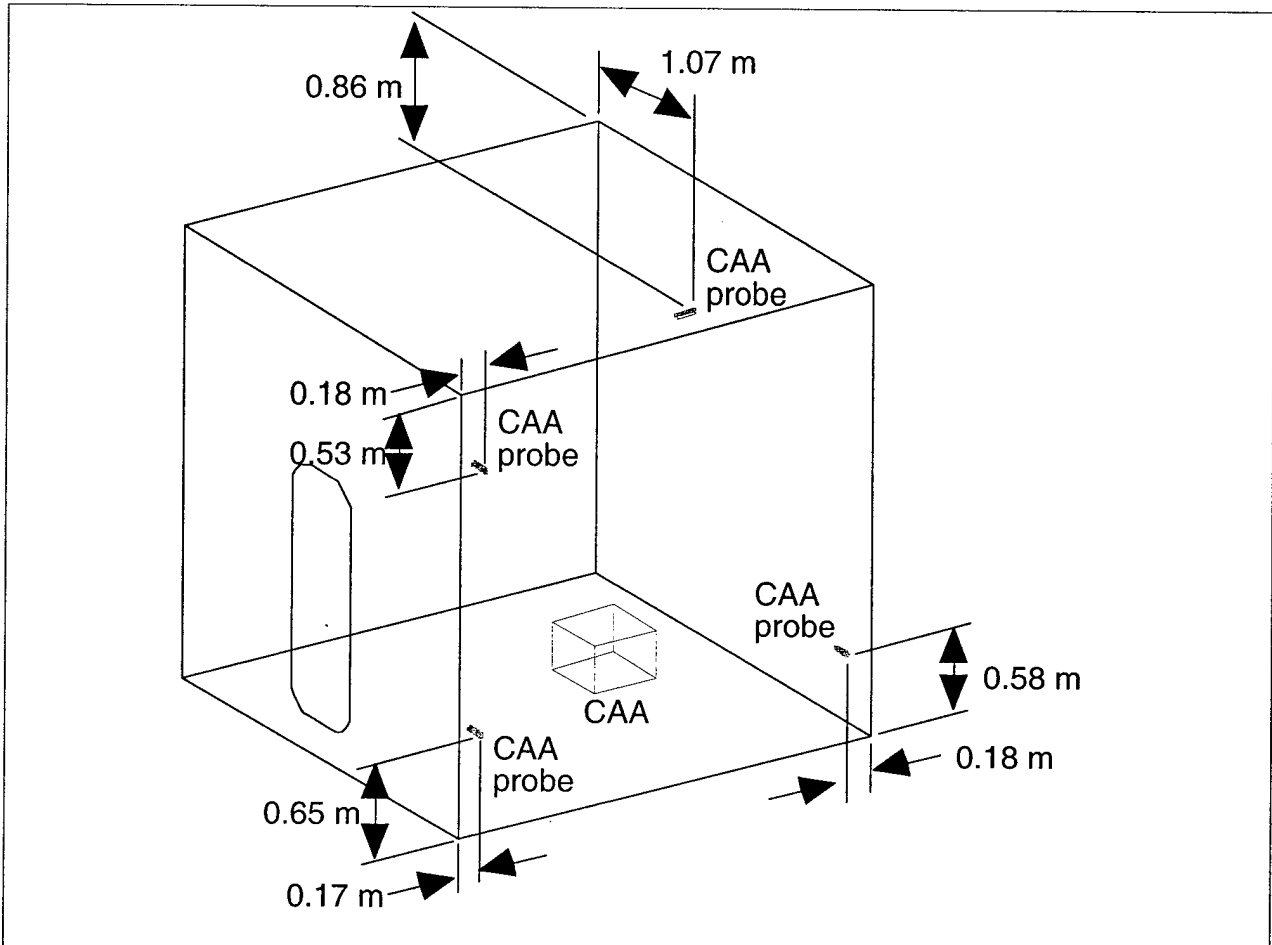

Figure 18. Continuous Acid Analyzer Locations

Locations of the four CAA sample probes within FLSR 1 are indicated. One additional CAA was placed on the deck inside the compartment. The only CAA that was consistently available during all tests discussed in this report was located externally (in the exhaust stack) and is not shown. For clarity, the internal stiffeners have not been shown.

2.3 Halon Replacement Test Procedures

The procedures used during the Halon Replacement Test Program were intended to replicate actual shipboard total flooding procedures as closely as possible. For discussion purposes, Figure 19 illustrates a standard shipboard event sequence. Note that the triangles indicate discrete events while the bars represent activities that require some time to complete. The length of the bars is not intended to be indicative of the actual time that each action may require. Fire growth is a special case in that it could continue for an indeterminate period before the detection event. Once the fire has been detected, the remaining events are, at least in principle, under the control of the crew.

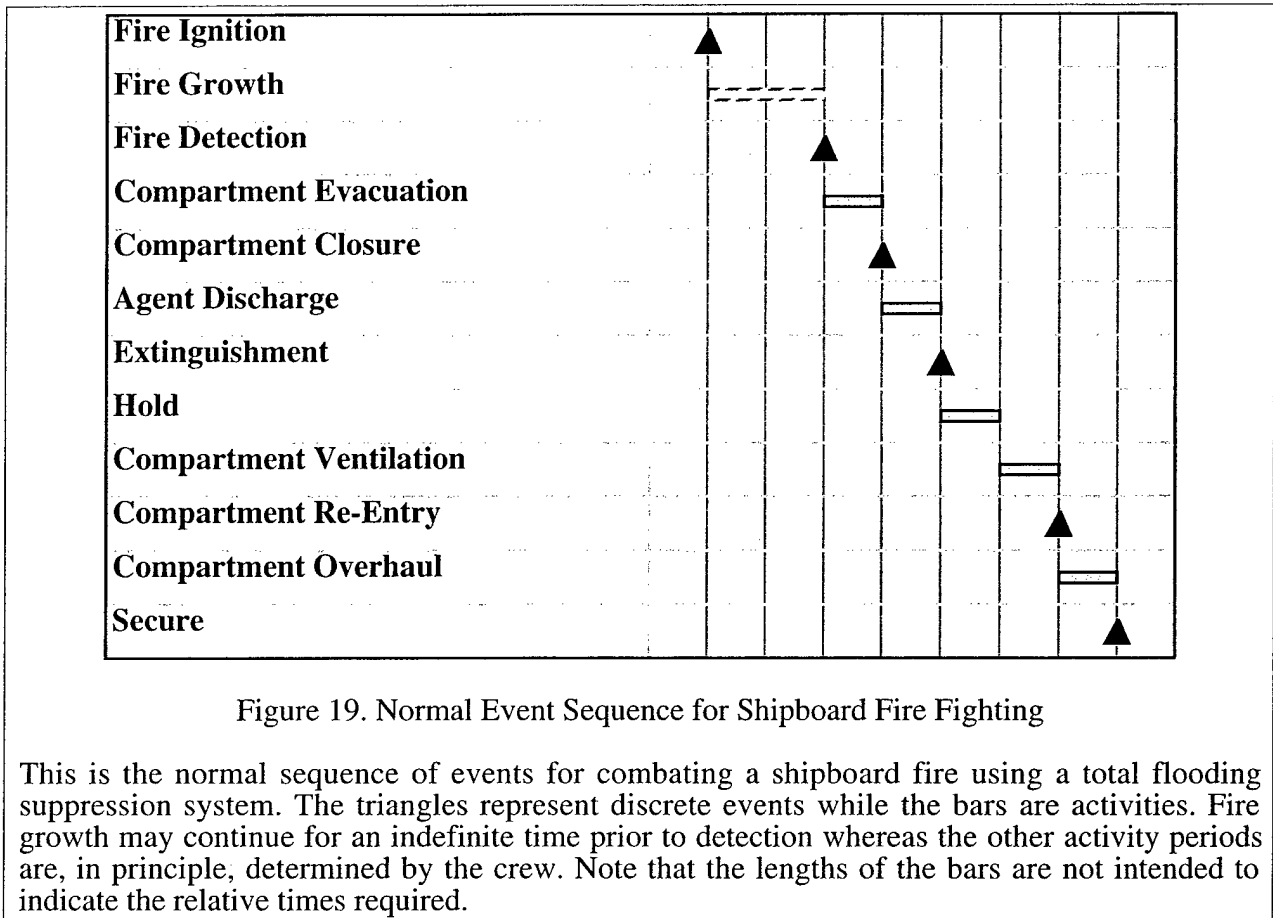

Figure 19. Normal Event Sequence for Shipboard Fire Fighting

This is the normal sequence of events for combating a shipboard fire using a total flooding suppression system. The triangles represent discrete events while the bars are activities. Fire growth may continue for an indefinite time prior to detection whereas the other activity periods are, in principle, determined by the crew. Note that the lengths of the bars are not intended to indicate the relative times required.

Because gaseous agents produce toxic byproducts during extinguishment, it is necessary to evacuate the compartment before activating the suppression system. Also, the space must be closed prior to discharge because these agents are only effective above a critical concentration. This includes securing the ventilation system, as well as the hatches and watertight doors.

Once the threshold agent concentration is reached, the fire is almost instantaneously extinguished so the period indicated as "Agent Discharge" in the figure includes the time required to distribute the agent throughout the protected space. Following extinguishment, there is a hold time to allow the compartment to cool before it is ventilated. If venting occurs too early, the agent will be flushed out, and oxygen replenished, while there is still a reignition hazard.

Once the danger of reignition is past, the ventilation system² is reactivated to remove the toxic combustion products and restore the oxygen concentration to normal levels. At that point, it is safe for personnel to re-enter and begin the process of overhauling the compartment.

For the Halon Replacement Program tests discussed in this report, the 120 second pre-burn period was intended to mimic both the undetected fire growth phase and the time that would be required to evacuate and secure the compartment. For these tests, zero time was defined as the time at which the suppression system was (or, in case of baseline tests, would have been) activated.

² In the event that the installed ventilation system is inoperable after the fire, ventilation is accomplished using portable blowers connected to flexible ducting.

2.3.1 Reignition procedures

The reignition tests were exceptions to the rule that test procedures mimicked shipboard procedures — clearly, in an actual fire, there would be no attempted reignition after extinguishment was completed. However, there is always the danger of an accidental reignition triggered by hot metal, an electrical short circuit or some other ignition source. The reignition procedure was designed to provide such a source in order to evaluate the reflash potential under various circumstances.

The heat source for these tests was an electrically heated glow rod. Different procedures were used for the cascade-plus-pan and for the cascade-only scenarios. For the former, a glow rod was placed directly above the pan and maintained at a temperature above the fuel vapor flash point for the duration of the test. With this configuration, ignition was potentially possible at any time. For the cascade-only cases, the glow rod was placed in the fuel cascade and was continuously heated. However, this procedure alone was insufficient because it did not guarantee that fuel would always be present. Therefore, the cascade was switched on for five-second intervals at various times during the test. As a result, reignition events were unlikely except during these discrete test periods.

No reignitions were expected prior to ventilation of the compartment, but reignition attempts were made several times (typically, at 5, 10 and 15 minutes after agent discharge) during the hold period in order to confirm this expectation³. In addition, attempts were made at one-minute intervals during ventilation to determine the point at which protection failed under various operating conditions.

2.4 WSCS Test Procedures

Conceptually, the WSCS could profitably be used during either the pre- or post-extinguishment periods, as illustrated in Figure 20. Because it is not toxic, WSCS could be activated immediately upon fire detection, unlike the gaseous agent suppression system. In this mode, it would be expected to cool the fire and surroundings, with two primary benefits: 1) partial suppression of the fire and 2) reduction of the amount of agent required to complete extinguishment, resulting in reduced HF production. As a result, it is likely that there would be less heat damage to the compartment, less HF to be removed and that re-entry could be accomplished more quickly. When used during the hold and ventilation periods, the WSCS could expedite compartment cooling and acid gas removal via scrubbing, again improving re-entry times. The compartment cooling effect would also reduce the probability of reignition by reducing fuel evaporation and cooling potential ignition sources.

In order to evaluate these operating modes, the WSCS tests involved activation of the water spray at different times, relative to discharge of the extinguishing system, and for different durations. In some cases, multiple WSCS activations were used during a single test. Several different water flow rates were tried in different tests.

The primary WSCS activation events occurred during the compartment evacuation and agent discharge periods. In some cases, additional activations were scheduled immediately prior to reignition attempts in order to investigate WSCS effects on reignition. In other cases, the WSCS was manually activated after reignition occurred in an attempt to reduce HF generation and increase HF scrubbing.

³ The specification for gaseous Halon 1301 replacement agents requires that no reignitions occur during the hold period. Thus, reignitions during this period would have constituted a serious fire protection failure.

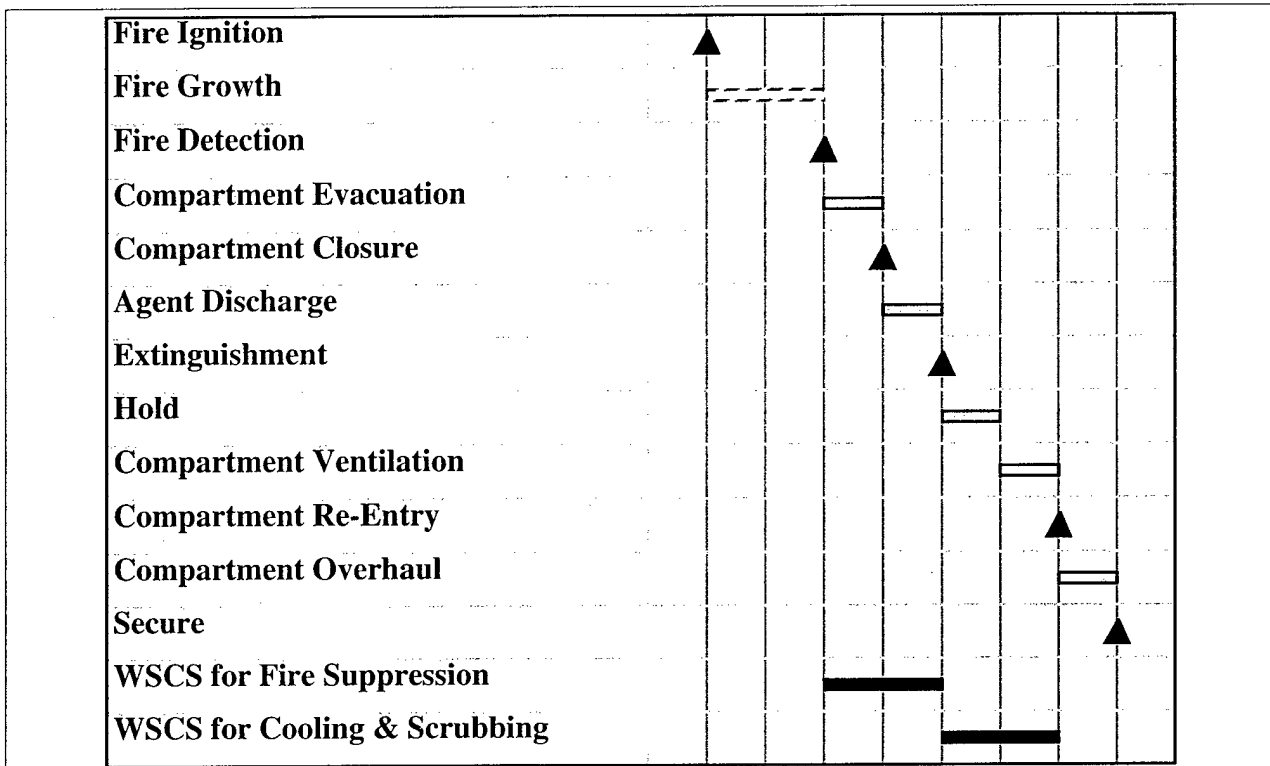

Figure 20. Possible Modified Event Sequence for Shipboard Fire Fighting with WSCS

The WSCS could be applied during either, or both, of two periods. First, it could be used for suppression starting at fire detection and continuing until extinguishment. Second, it could contribute to compartment cooling and scrubbing of toxic products during the hold and ventilation periods.

3.0 DATA ANALYSIS

These preliminary tests were intended to demonstrate the WSCS concept and provide scoping data to guide future test programs. Accordingly, they were designed to cover a broad range of operating parameters, including WSCS initiation time, application duration, number of applications and application rate. It was not feasible to meet these goals and simultaneously conduct replicate tests to determine reproducibility. Therefore, the results reported below are considered to be representative of the qualitative behavior that may be expected from WSCS, but may not be quantitatively accurate.

3.1 Selection of Tests

There were a total of 108 FLSR 1 tests conducted under the auspices of the FLSR 1 Halon Replacement Program. Figures 21A – 21E show a tree diagram illustrating the relationships among the various tests. All tests have been categorized according to the values of each of the major parameters. These parameters (for example, status of the WSCS, type of fuel and presence of a pan fire in addition to the cascade) appear in a column on the left of each figure. Each box in the figure displays the value of the specified parameter and, in parentheses, the number of tests that meet the cumulative criteria. For example, there were 31 tests in which WSCS was not used, the fuel was MeOH and there was no pan fire (Figure 21A).

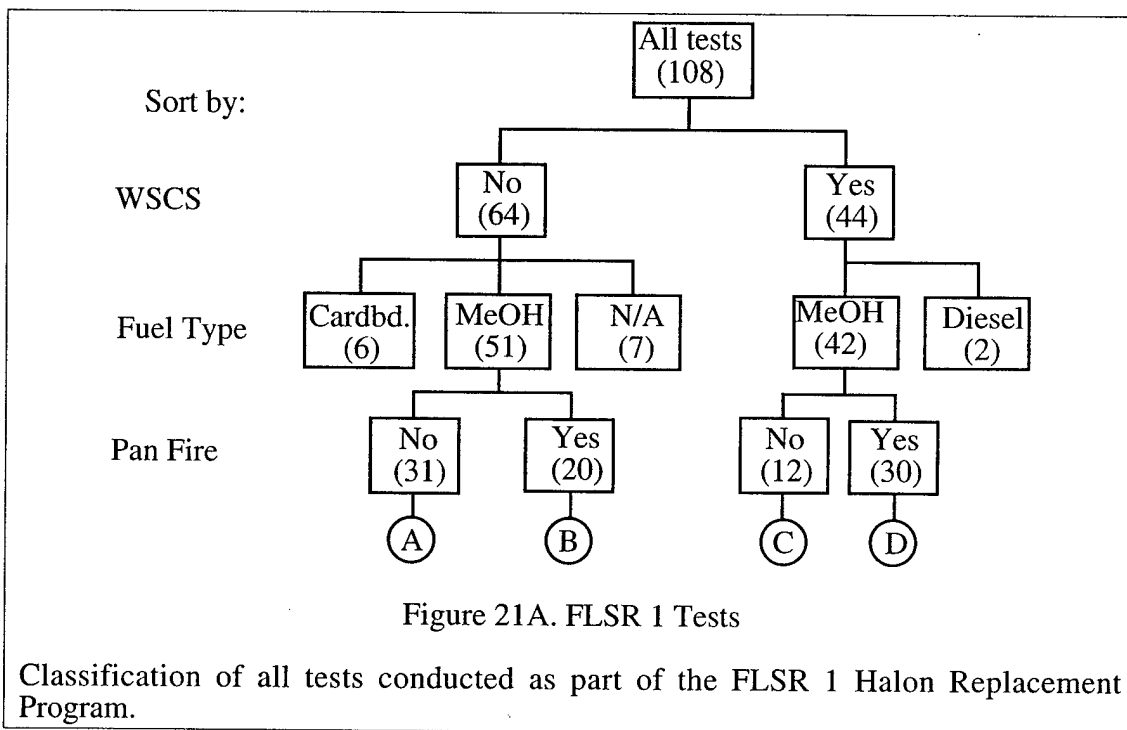

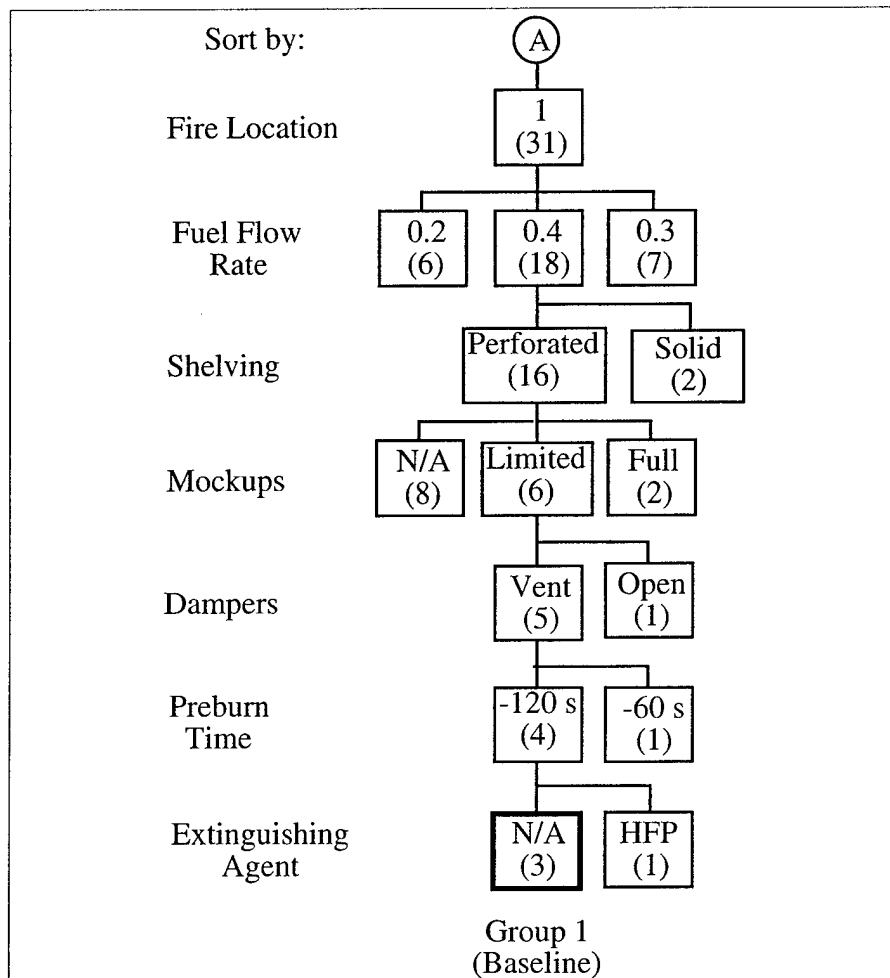

Figure 21B. FLSR 1 Tests

Group 1 Baseline tests involved neither extinguishment nor use of the WSCS. The "Vent" notation indicates the standard ventilation sequence in which dampers were closed just prior to agent discharge and reopened at +1200 seconds, at the end of the hold period; "Open" indicates that the dampers were never closed.

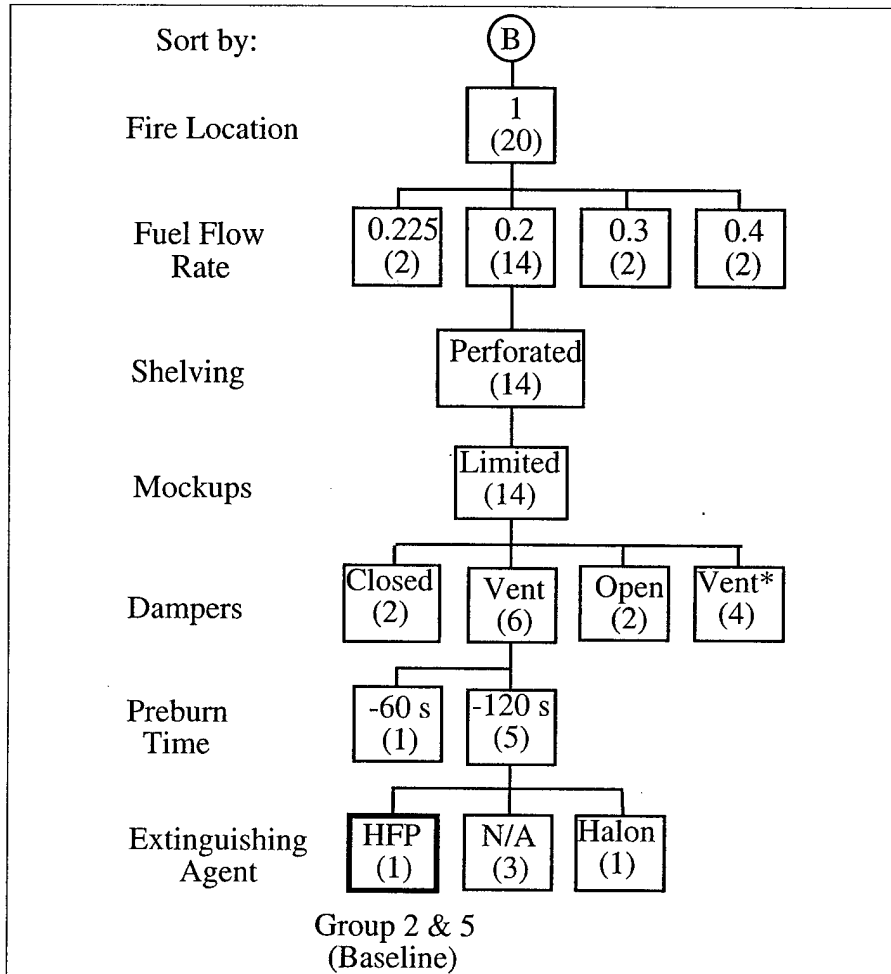

Figure 21C. FLSR 1 Tests

Group 2 and Group 5 Baseline tests involved extinguishment without the use of the WSCS. The "Vent" notation indicates the standard ventilation sequence in which dampers were closed just prior to agent discharge and reopened at +1200 seconds, at the end of the hold period; "Open" indicates that the dampers were never closed; "Closed" indicates that they were not reopened and "Vent*" indicates that they were reopened at a time other than +1200 seconds.

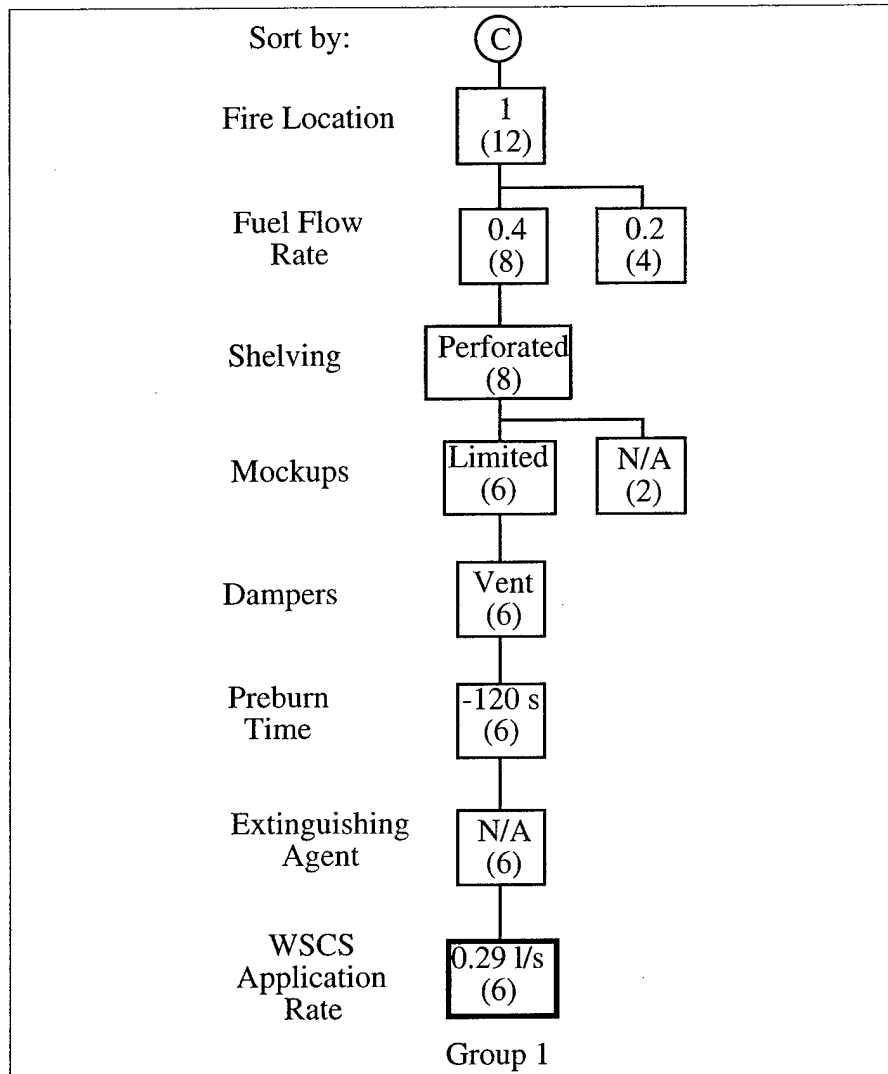

Figure 21D. FLSR 1 Tests

Group 1 tests involved use of the WSCS but no extinguishment. The "Vent" notation indicates the standard ventilation sequence in which dampers were closed just prior to agent discharge and reopened at +1200 seconds.

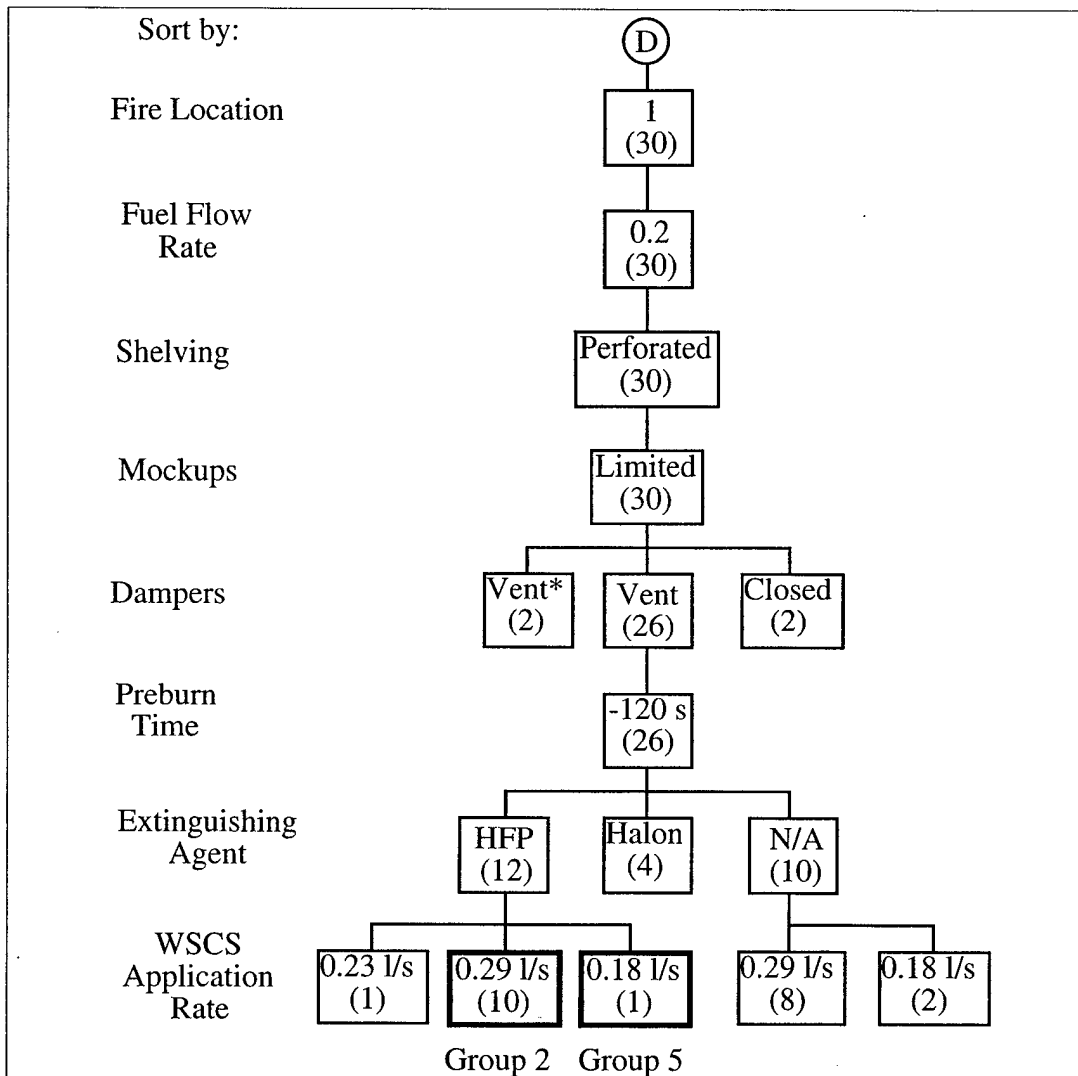

Figure 21E. FLSR 1 Tests

Group 2 and Group 5 tests involved both extinguishment and use of the WSCS. The "Vent" notation indicates the standard ventilation sequence in which dampers were closed just prior to agent discharge and reopened at +1200 seconds, at the end of the hold period; "Closed" indicates that they were not reopened and "Vent*" indicates that they were reopened at a time other than +1200 seconds.

Some of the parameters shown in Figure 21 require additional explanation. The original FLSR 1 Halon Replacement Program test plan specified three fire locations but only one of these, Fire Location 1⁴, was actually within the shelving area. Since that was the region of most concern, all but eight tests used that location.

As was previously mentioned, all of the tests considered in this report made use of the perforated, rather than solid, shelf plates. Various containers, including the 19 l (five gallon) pails shown in Figure 7, were placed on the shelves to simulate the obstructions that are normally present in actual shipboard flammable liquid storage rooms. These partially loaded shelving configurations were referred to as "limited" mockups.

There were also a few tests in which mockups were not used and some in which "full" mockups were used. For the latter cases, 208 l (55 gallon) drums and additional 19 l (five gallon) pails occupied much of the free deck area in the center of FLSR 1 and along the starboard bulkhead in order to reduce the free volume of the compartment. Only tests with "limited" mockups are considered in this report.

Group	Test	Fuel Flow		WSCS Rate (l/s)	WSCS Flow	
		Start*	Stop*		Start*	Stop*
1 Base	3.5_LM	-120	10	NA	NA	NA
1 Base	3.5_LM_DO	-120	10	NA	NA	NA
1 Base	3.6	-120	10	NA	NA	NA
1 (A)	6.1P	-120	10	0.29	-60	60
1 (A)	6.2P	-120	10	0.29	-90	30
1 (A)	6.3P	-120	10	0.29	-120	0
1 (B)	6.4P	-120	30	0.29	-45	30
1 (B)	6.6P	-120	30	0.29	-30	30
1 (B)	6.8P	-120	30	0.29	-15	30
2 Base	5.4	-120	30	NA	NA	NA
2	6.1	-120	30	0.29	-60	60
2	6.2_LF	-120	30	0.29	-30	60
2	9.1	-120	30	0.29	0	90
5 Base	Same as Group 2 Baseline					
5	7.1	-120	30	0.18	-30	60

Table 1. Summary of WSCS Test Parameters

All tests that were analyzed for this report are included in this table. The group numbers are defined in Figure 21. For each group, the baseline tests differed only in that the WSCS was not activated. WSCS start and stop times apply only to the first application (in some tests, there were subsequent applications, typically at about 1000 seconds).

* Time (in seconds) after gaseous agent discharge.

In accordance with standard practice, the FLSR 1 ventilation system was secured and the dampers were closed prior to discharge of the suppression agent. In most tests, 1200 seconds was allowed for the cooling and hold periods after which ventilation was restarted. In a few cases, the dampers were left open (to simulate a damper actuator failure), were kept closed for the entire

⁴ Fire location 1 was a few centimeters aft of thermocouple tree 1 (see Figure 17).

test or (as indicated by the Vent* notation in Figures 21C and 21E) the ventilation was reactivated at a non-standard time.

The tests meeting certain criteria were placed into five categories, indicated by the boxes shown in bold in Figures 21B - 21E. For reference, each of these subsets was given a group number (Group 1 - 5) which appears below the appropriate box. For each group, there is a baseline configuration that did not involve use of the WSCS and a test configuration that did.

We first chose WSCS tests, then identified the corresponding non-WSCS (baseline) cases. Group 1 tests were the simplest case because no gaseous extinguishing agent was involved. This allowed us to concentrate on "pure" WSCS effects. Group 2 tests were similar to Group 1, except that HFP was used to extinguish the fires and the fuel flow rate was lower. Groups 3 and 4 are not discussed here — Group 3 essentially duplicated Group 1 (albeit, at a lower fuel flow rate) and there were no baseline tests corresponding to Group 4. Group 5 was subsequently added in order to investigate the effects of a reduced WSCS flow rate.

Table 1 provides a list of all the tests used in this work, organized according to group number. Not all of the Group 2 tests were included in this analysis. One involved a special ventilation configuration for which no baseline was available and one used a non-standard HFP concentration. In five of the cases, the first application of the WSCS occurred very late in the test (typically, 900 - 1200 seconds after extinguishment) and therefore had no effect on the fire or its immediate aftermath. Accordingly, those seven tests are not discussed in this report.

For each test, the fuel flow start and stop times are given and, for the WSCS tests, the water flow start and stop times and the flow rate are included. All times are in seconds relative to the gaseous agent discharge time.

3.2 Data Analysis Procedures

A preliminary inspection of thermocouple data from several tests revealed that there was considerable noise on many channels. Typical data, from Tree 1 of baseline test 6.1P, are shown in Figure 22. Expansion of the time axis revealed that the noise consisted of several different frequency components, as seen in Figure 23. There appears to be a low frequency signal (near 0.06 Hz) superimposed on the high frequency noise. In some test, there was an even lower frequency signal, in the 0.01 Hz range.

These apparently systematic low frequency variations are believed to be due to interference from several military communications systems that are located near the CBD test site. In order to remove this noise, the data were smoothed using a boxcar filter algorithm having a 35 point (17.5 second) window. This filter was specifically targeted at the approximately 0.06 Hz component. No attempt was made to remove the 0.01 Hz signal, primarily because it appeared only on a few channels in a small number of tests.

For comparison, the results of the smoothing process are shown, for a typical case, in Figure 24. Although not all data were this noisy, this smoothing procedure was adopted as a standard in order to maintain consistency across all data channels.

As expected, we also found that the temperatures recorded, at the same elevations, were significantly higher for Tree 1 than for the other three trees. Trees 3 and 4 were consistently the lowest temperatures and were in very good agreement with each other while the Tree 2 temperatures were intermediate. The thermocouples below the 1.52-m (5.0-ft) level showed almost no response, indicating that stratification occurred somewhere between 1.14 m (3.7 ft) and 1.52 m (5.0 ft).

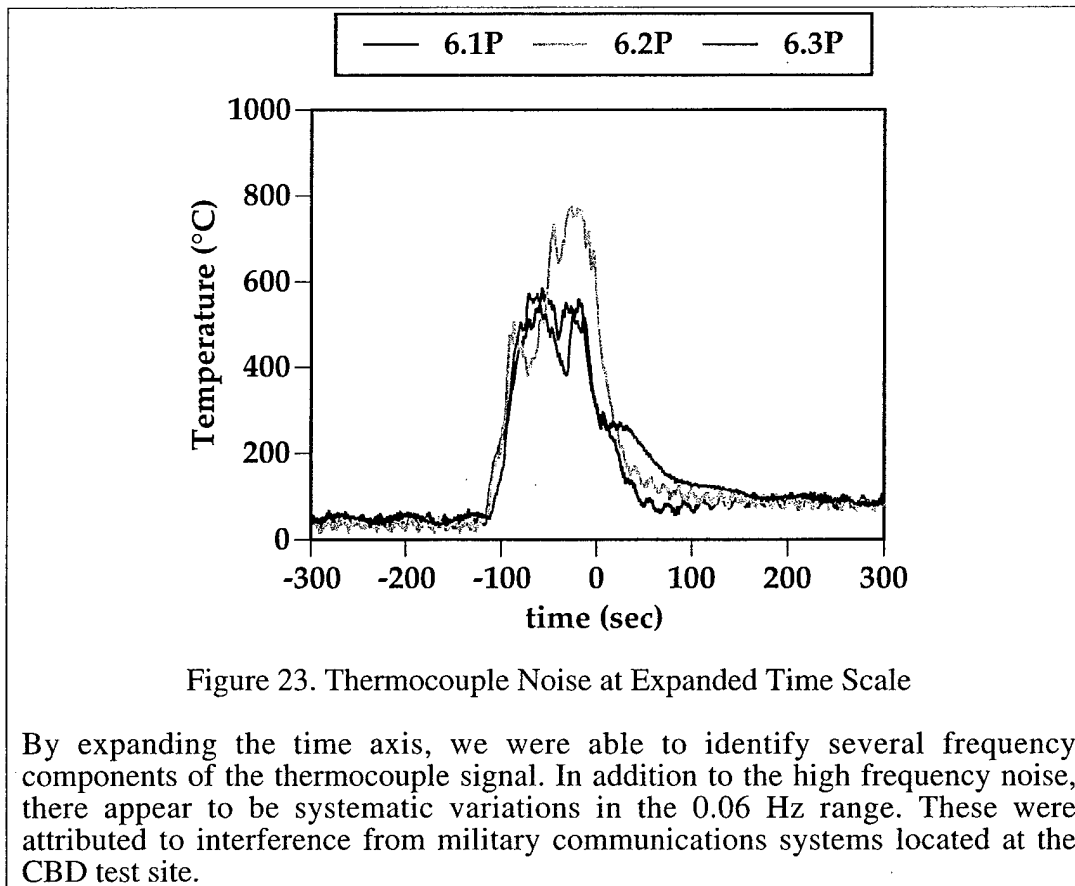
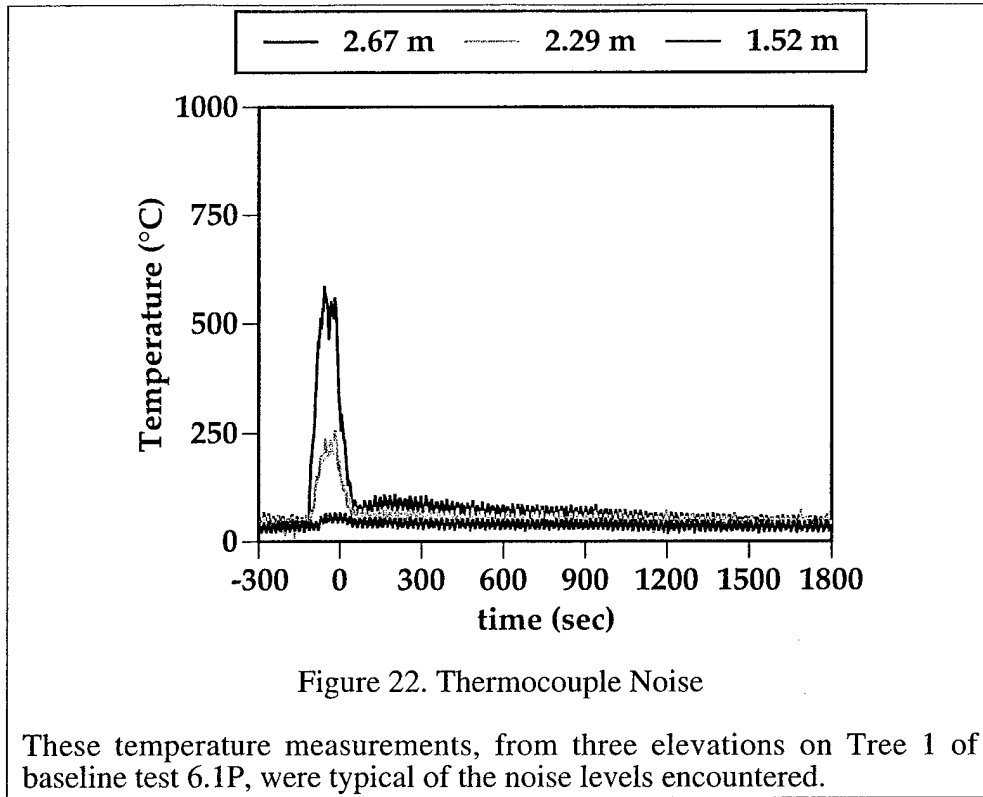

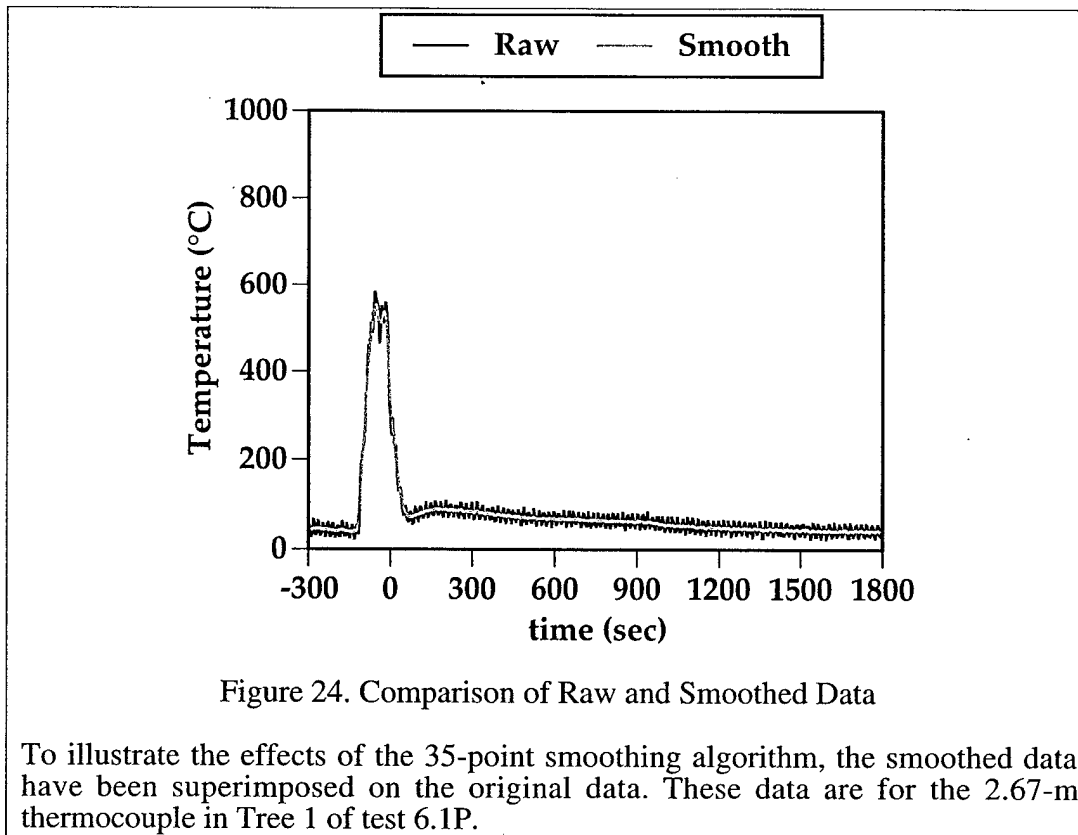

Based on these observations, we chose to focus on the behavior of the topmost thermocouples on Tree 1 and Tree 3. The former is considered to be representative of the conditions near the fire while the latter is more characteristic of the general thermal environment within the compartment. Using the thermocouples at the highest elevations provides information regarding what is likely to be the worst case for both the fire and the overall compartment temperatures.

Although there was not enough data to perform meaningful statistics for most cases, there were several replicates of the Group 1 Baseline tests. We took advantage of this fact to investigate the reproducibility of those tests. As may be seen from the error bars (one standard deviation), repeatability was very good for both Tree 1 (Figure 25A) and Tree 3 (Figure 25B).

Of course, good reproducibility among these tests is no guarantee that agreement would be equally good for other tests but, in the absence of evidence that these tests were in any way unique, we take this to be an estimate of the typical experimental reproducibility.

The CAA units were somewhat delicate and prone to failure in the harsh environment of FLSR 1. As a result, although six CAA units were used in each test, typically only two or three (sometimes, only one) produced useful data. Only the CAA that was located in the exhaust stack outside the compartment consistently provided HF concentration data for all tests. Consequently, we relied on that device for all comparisons between experiment.

Like the temperature data discussed above, data from the CAAs were also very noisy. Unlike the temperature data, the CAAs did not show any clear signs of interference from external sources, possibly because the signals were processed and amplified before being transmitted back to the data acquisition system. We found the filtering process devised for the thermocouples to be advantageous for the CAAs so they were also smoothed with a 17.5-second window.

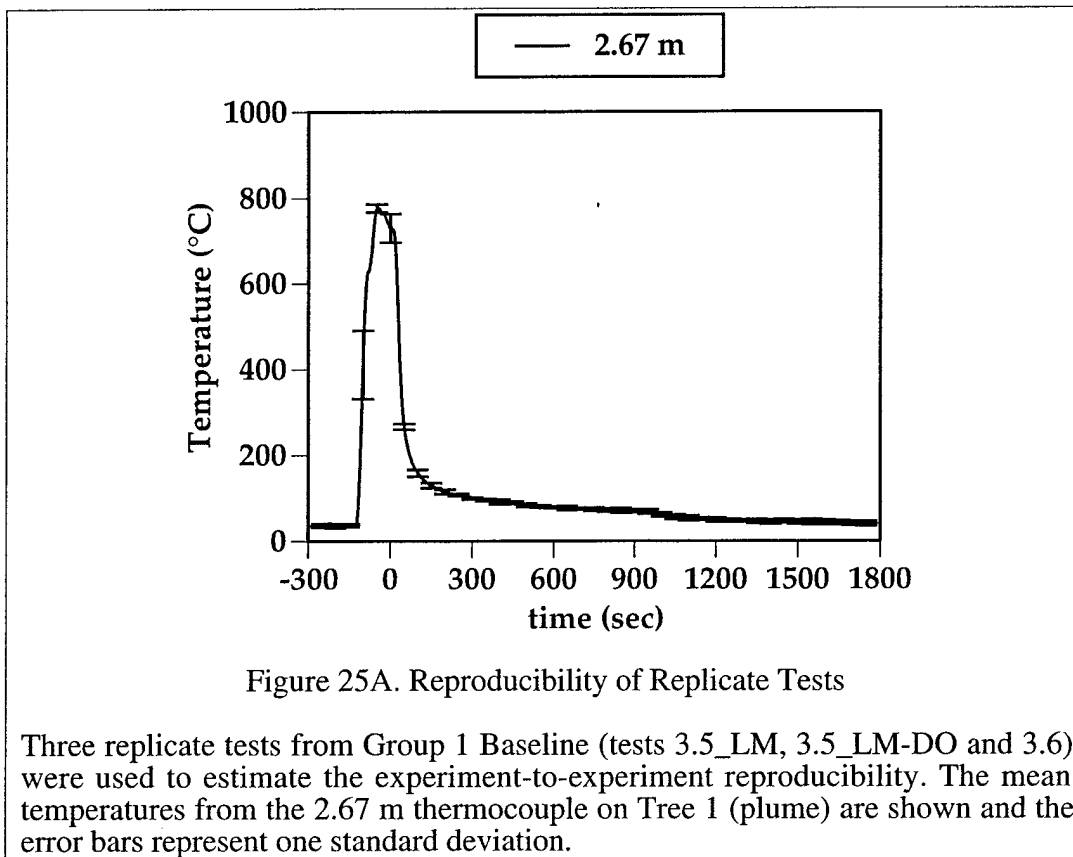

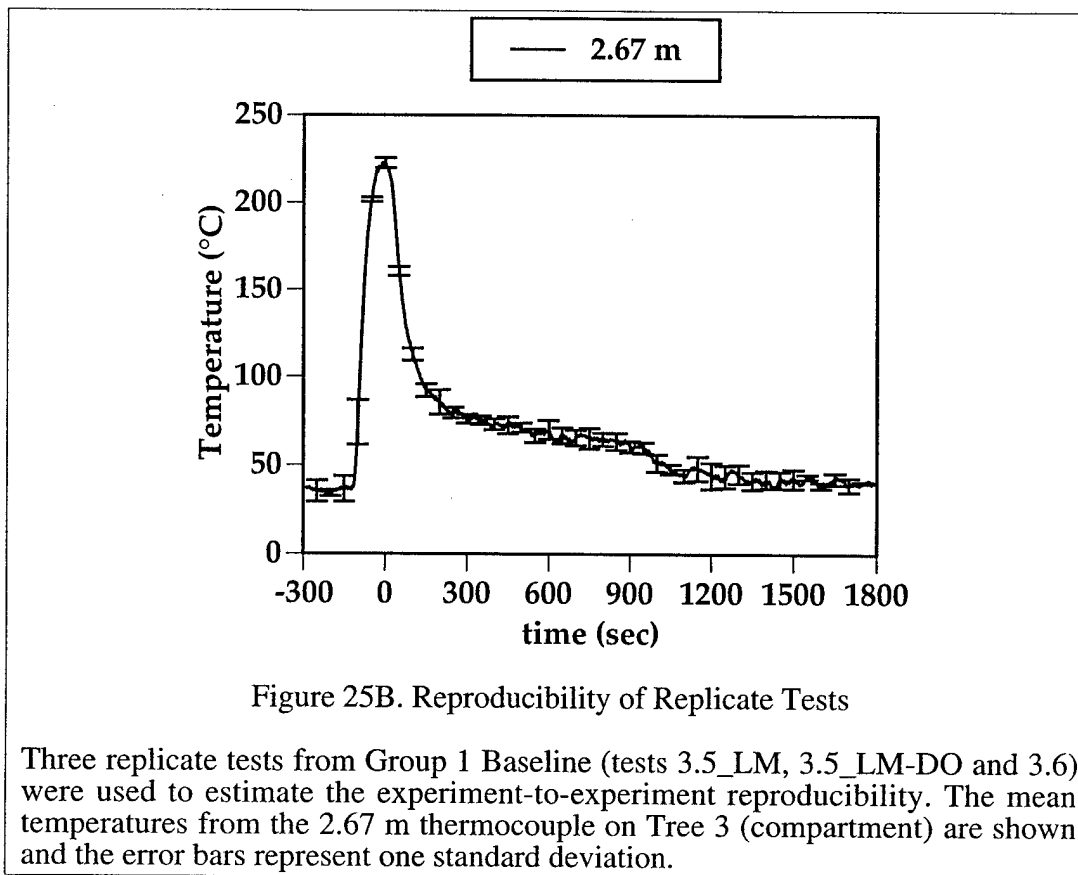

4.0 RESULTS

The general characteristics of the various test groups are presented in Table 2. As may be readily seen, comparison of Group 1 tests with the Group 1 Baseline test provides information regarding the effects of the WSCS in the absence of extinguishing agent. Likewise, Groups 2 and 5 illustrate the combined effects of the WSCS and HFP at two different water application rates.

Group	Agent	WSCS (l/s)
Group 1	N/A	0.29
Group 1 Baseline	N/A	N/A
Group 2	HFP	0.29
Group 2 Baseline	HFP	N/A
Group 5	HFP	0.18
Group 5 Baseline	Same as Group 2 Baseline	

Table 2. Characteristics of Group 1, 2 and 5 Tests
The fire suppression and WSCS flow rate characteristics of Groups 1, 2 and 5, and the corresponding baselines, are shown.

Because the ambient temperatures differed from test to test, each test started from a different initial temperature. Although the ambient HF concentrations should have been zero for all tests, the CAA outputs actually showed apparently random offsets which were attributed to differences

in the instrument calibrations. In order to make test-to-test comparisons easier, we chose to plot temperature and concentration differences, rather than absolute values.

These corrections were made by subtracting the mean pre-ignition value of each instrument from all readings produced by that sensor. The pre-ignition mean was calculated over the period between starting the data acquisition system and beginning of the pre-burn. For the experiments considered here, this period was always 180 seconds. Note also that the zero time for all tests was defined to be the time at which the gaseous agent suppression system was, or would have been, activated. By this definition, data acquisition began at -300 seconds.

Temperature and HF concentration plots are given in Appendices A - C for Groups 1, 2 and 5, respectively, except, of course, that there was no HF produced in Group 1 tests because they did not involve gaseous agent fire suppression. Some of these graphs have also been included in the body of this report in order to illustrate specific points. Graphs for all tests shown in Table 1 are included in the appendices.

For each graph, we compare a single test with the corresponding baseline test(s). The black horizontal bar represents the period during which fuel was flowing and the gray bars indicate the times that the WSCS was active. All tests have at least one such WSCS interval and some have as many as three. In addition, for the tests in which HFP was applied, there are inverted triangles showing when reignitions occurred. The black and gray triangles apply to the baseline and WSCS cases, respectively.

4.1 Group 1 — No Suppression

Group 1 tests involved MeOH cascade fires with a fuel flow rate of 0.4 l/s. Perforated shelves were used with "limited" mockups. Dampers were closed and ventilation secured just prior to time zero (the nominal agent discharge time). Ventilation was resumed at the end of the hold period. The preburn time was 120 seconds and the WSCS application rate (for non-baseline tests) was 0.29 l/s.

Within Group 1, there were two distinct subgroups, which we have designated A and B. In A, comprising tests 6.1P, 6.2P and 6.3P, the WSCS was activated for 120 seconds but the time of activation varied. For subgroup B (test 6.4P, 6.6P and 6.8P), both activation time and WSCS duration were varied so that the WSCS deactivation time was always at +30 seconds. Activation and deactivation times for all tests were given in Table 1.

All of the WSCS procedures tried resulted in some decrease in fire plume temperature, but the amount of the decrease varied from negligible (test 6.2P, shown in Figure 26) to about 250 °C (test 6.3P; Figure 27).

Differences between the two subgroups were more dramatic for the general compartment temperatures (thermocouple Tree 3). Here, subgroup A showed large relative decreases in peak temperatures, although the absolute temperature drops were smaller (in the range of 50 - 150°C) because the baseline compartment temperatures were lower. A typical case (test 6.1P) is shown in Figure 28. In contrast, subgroup B produced no decrease in peak temperatures — in fact, they were very slightly increased, as seen in Figure 29 (test 6.4P). Both groups showed a significant decrease in the total thermal insult (time - temperature product), but this effect appears to be somewhat greater for experiments in subgroup A. In actual shipboard use, this would produce a lower integrated heat flux and, therefore, would be expected to reduce the amount of fire damage.

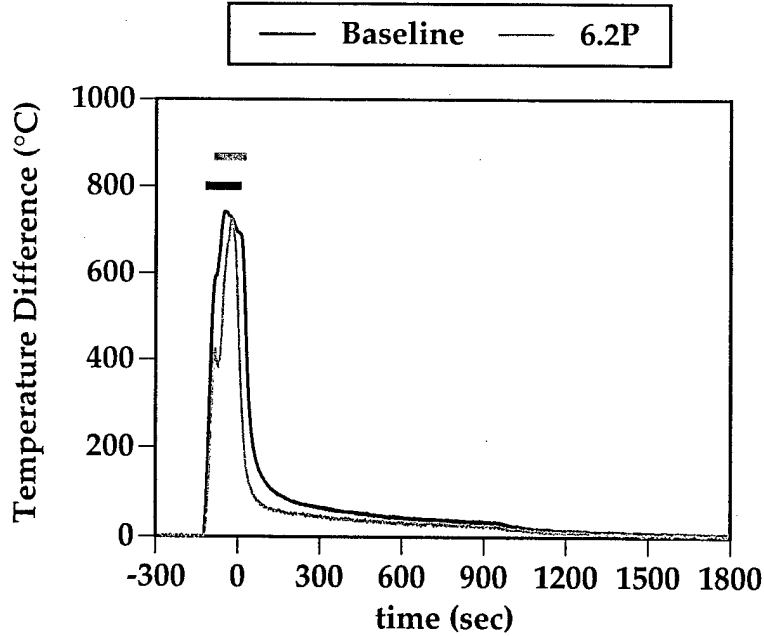

Figure 26. Negligible WSCS Effect on Fire Plume Temperatures

In test 6.2P, the WSCS produced very little cooling of the fire plume.

Key: Black bar – fuel flow period; Gray bar – WSCS activation period

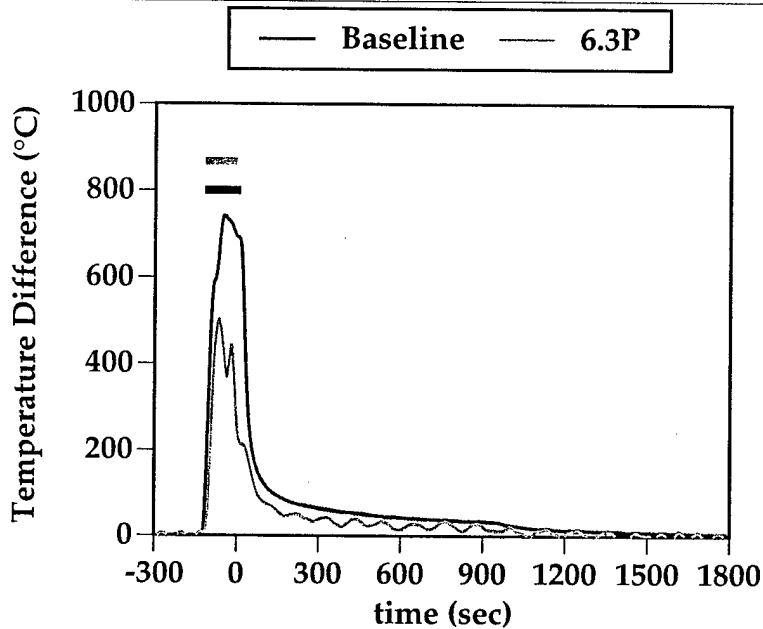

Figure 27. Significant WSCS Effect on Fire Plume Temperatures

In test 6.3P, the WSCS reduced the peak fire plume temperature by about 250°C.

Key: Black bar – fuel flow period; Gray bar – WSCS activation period

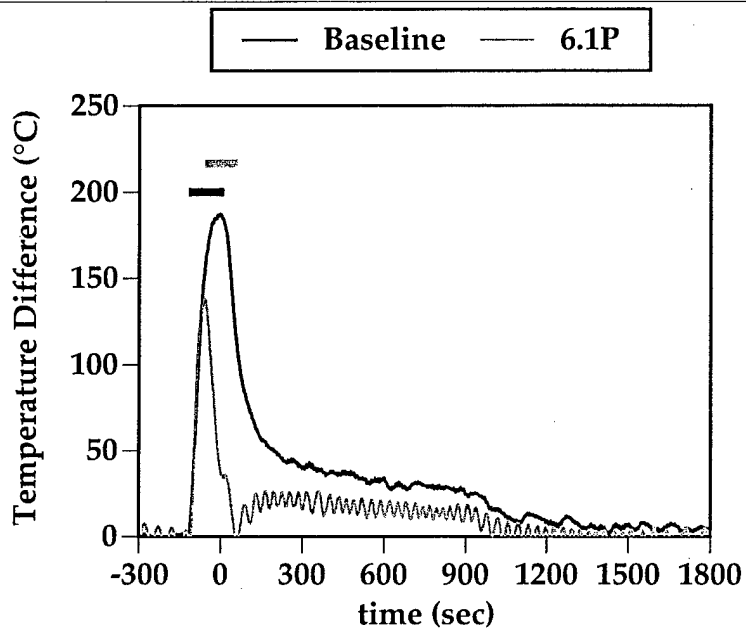

Figure 28. Effect of Rapid WSCS Activation on Compartment Temperatures

When applied early (-60 sec) and for an extended period (120 sec), the WSCS reduced peak compartment temperatures by 50 - 150°C. Test 6.1P was typical.

Key: Black bar – fuel flow period; Gray bar – WSCS activation period

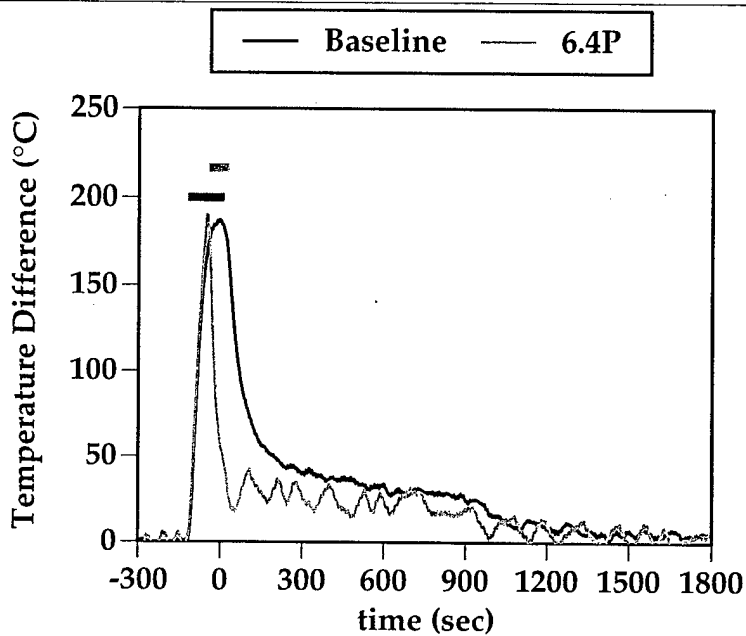

Figure 29. Effect of Delayed WSCS Activation on Compartment Temperatures

When application was delayed (-45 sec) and of shorter duration (75 sec), the WSCS had little effect on the peak compartment temperature but did significantly reduce the total thermal insult. Test 6.4P was typical.

Key: Black bar – fuel flow period
 Gray bar – WSCS activation period

Since the effect of the WSCS on compartment ambient conditions was virtually instantaneous (note the coincidence between WSCS activation and temperature drop in Figures 28 and 29), the reduced effect on peak temperatures in Group B tests was attributed to the delayed activation of the system. Essentially, the compartment had already reached its peak temperature before the WSCS came into play.

4.2 Groups 2 and 5 — Combined Suppression and WSCS

The tests in Groups 2 and 5 were combined cascade and pan fires with MeOH flowing at 0.2 l/s. "Limited" mockups were used with perforated shelves. With the exception of one test in which the compartment door was left open, the ventilation was similar to Group 1. A 120-second preburn time was used. WSCS application rates were 0.29 l/s for Group 2 and 0.18 l/s for Group 5.

As we noted previously, seven of the Group 2 tests were not included in this analysis. Two were left out because they involved non-standard configurations and five because the first WSCS application was delayed until very late in the test. In the next sections, we discuss the results of the remaining tests, considering first the WSCS effects on temperature and then the effects on the HF concentration.

4.2.1 Effects on temperature

In comparison with the no-suppression (Group 1) cases, the WSCS system typically had almost no effect on temperature when used in conjunction with HFP (Groups 2 and 5), as illustrated in Figures 30 and 31 (fire plume and compartment ambient temperatures, respectively). However, Figure 32 shows that a significant effect on the compartment temperature is possible, even when the WSCS and suppression systems are both used.

Figure 33 shows the effects of reducing the WSCS flow rate from 0.29 l/s (test 6.1) to 0.18 l/s (test 7.1). Contrary to what might have been expected, the lower flow rate produced a somewhat greater temperature drop.

The primary reason for the small temperature differences between use of WSCS plus HFP versus use of HFP alone is believed to be that fire suppression occurred almost instantaneously at the time that the extinguishing agent was discharged. In the best case (test 6.1), the WSCS was activated only 60 seconds prior to that; in the worst case (test 9.1) WSCS activation was simultaneous with suppression. Thus, there was insufficient time for WSCS to act before extinguishment. In addition, the WSCS was secured almost immediately following extinguishment so it had no effects during the hold phase.

In several cases, reignitions occurred after ventilation was initiated, typically on the order of 1000 seconds after the fire had been extinguished, due to the loss of protection as the agent concentration dropped below the critical threshold. The temperature effects of these reignitions were clearly visible in the fire plume readings (see Figure 30) but were typically at or below the noise level for the compartment temperature (Figure 32) because the resulting fires were small and ventilation was on-going.

In some of these cases, such as tests 6.2_LF (Figure 30) and 7.1 (Figure 33), the WSCS was activated a second, or even a third, time. The latter is a particularly interesting case, because there are three separate ignition events (one for the baseline and two in the WSCS data) and each is accompanied by a temperature pulse. These secondary activations occurred at about the same time as the reignitions, but there is insufficient data to determine whether use of the WSCS had any effects on the reignitions.

4.2.2 Effects on HF concentration

Hydrogen fluoride concentrations were extremely variable, both from one experiment to another and also over time within a single experiment. In the absence of WSCS activation, the maximum HF concentrations were associated with reignition events, rather than with the initial fire. Typically, the latter produced peak HF values of about 2000 ppm while subsequent fires caused HF spikes on the order of 8000 ppm. This behavior was attributed to the fact that HFP suppressed the initial fire nearly instantly, allowing little time for sustained HF production. In contrast, reignitions occurred only after the HFP concentration was below the extinguishment threshold. As a result, there was a significant amount of HFP available for reaction but not enough to immediately quench the fire. Thus, these fires continued to burn for an extended time, producing HF all the while. During this period, HF production was limited only by the amount of residual fuel, which controlled the duration of the fire, and the amount of HFP available to be decomposed.

Because the damage control party must be protected from exposure to HF, compartment reclamation can not begin until HF concentrations have been reduced to acceptable levels. Ventilation procedures must also ensure that other personnel are not exposed to hazardous HF concentrations during the ventilation process. To put this in perspective, we note that the IDLH (immediate danger to life and health) value for HF is 30 ppm. Therefore, even the smaller amounts produced during the initial extinguishment present an immediate hazard to personnel. It follows that reducing HF levels by two or three orders of magnitude is an important goal. Reclamation procedures for HFP-protected compartments are currently under investigation.

Figures 34 - 37 show the HF values measured at the exhaust duct CAA (recall that, due to the hostile environment, that was the only analyzer which was consistently functional) for tests 6.1, 6.2_LF, 9.1 and 7.1, respectively. We see that peak HF concentrations during the extinguishment phase were reduced, in all cases, when the WSCS was employed. Except for test 9.1, the reduction was on the order of 50 - 75%. During the hold period, HF concentrations fluctuated in the baseline case but were consistently close to zero for the WSCS cases. This suggests that there was a significant scrubbing effect, in addition to a reduction in the amount initially generated.

The production of HF is a complex function of many variables, including fire size, fuel availability, HFP concentration and oxygen concentration. Because these tests were not designed to control those parameters during reignition, wide variations in HF production were observed. In three of these four WSCS tests (6.1, 6.2_LF and 7.1) the peak HF concentrations were again reduced but, in test 9.1, peak HF levels approximately doubled relative to the baseline. Also, in test 6.1, although the peak was lower, the integrated amount of HF was similar because production was spread over a longer time.

5.0 SUMMARY

This study constitutes a proof-of-principle of the WSCS concept. It has been shown that the WSCS can:

- a. significantly lower compartment temperatures;
- b. significantly reduce atmospheric HF concentrations; and
- c. reduce the fire intensity.

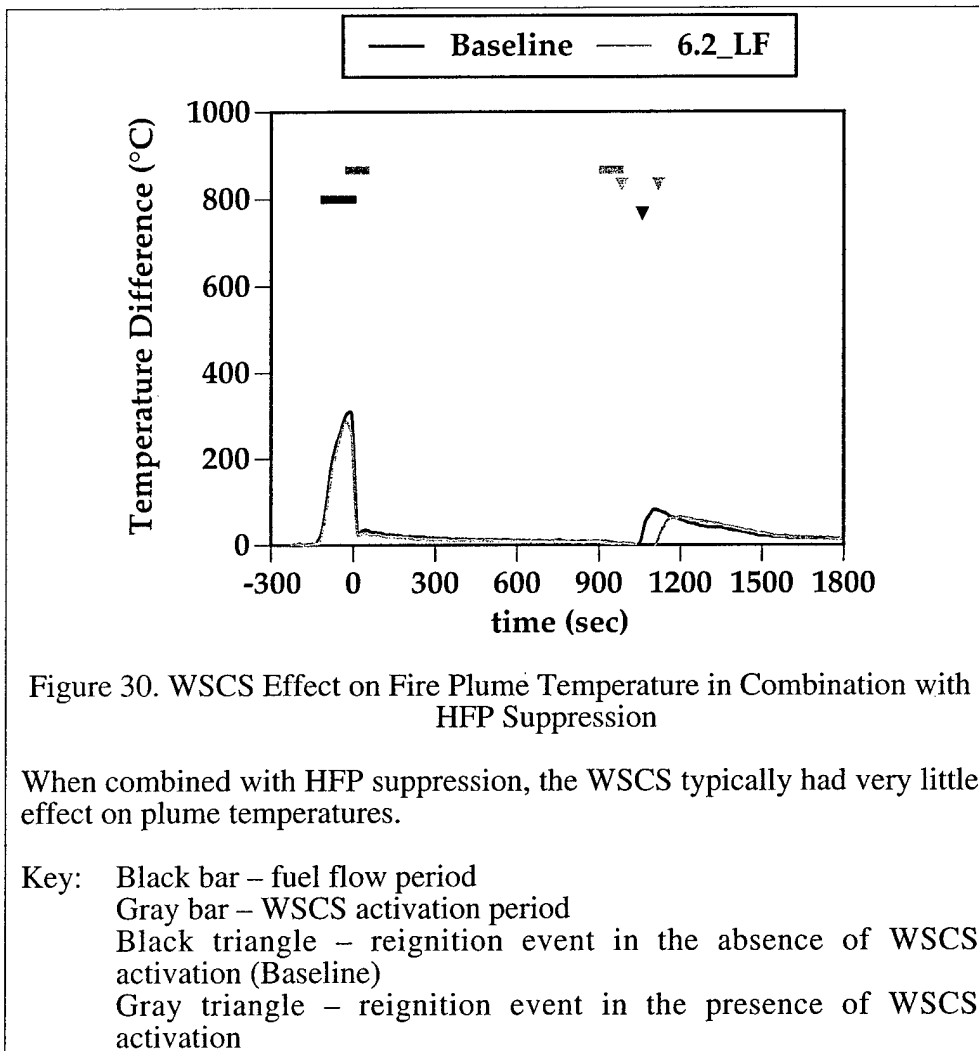

Figure 30. WSCS Effect on Fire Plume Temperature in Combination with HFP Suppression

When combined with HFP suppression, the WSCS typically had very little effect on plume temperatures.

- Key:
- Black bar – fuel flow period
 - Gray bar – WSCS activation period
 - Black triangle – reignition event in the absence of WSCS activation (Baseline)
 - Gray triangle – reignition event in the presence of WSCS activation

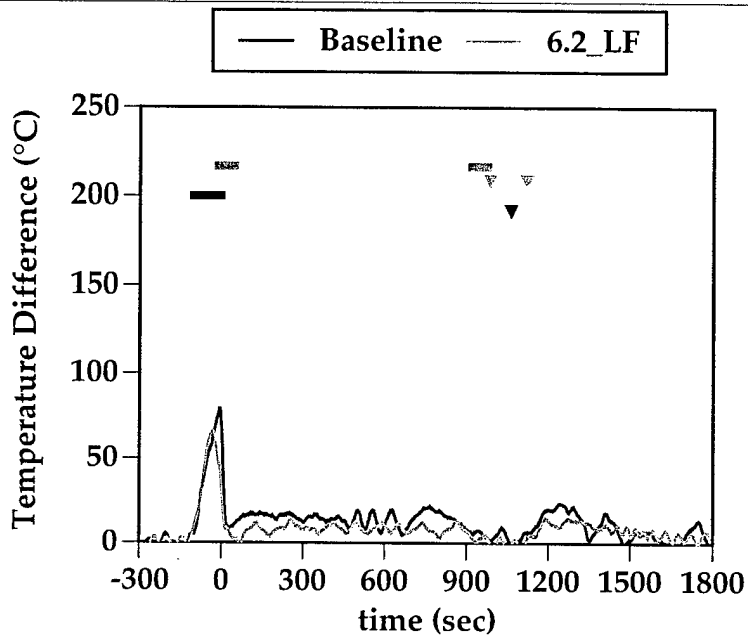

Figure 31. WSCS Effect on Compartment Temperature in Combination with HFP Suppression

When combined with HFP suppression, the WSCS usually had minimal effect on the compartment temperatures.

Key: Black bar – fuel flow period
 Gray bar – WSCS activation period
 Black triangle – reignition event in the absence of WSCS activation (Baseline)
 Gray triangle – reignition event in the presence of WSCS activation

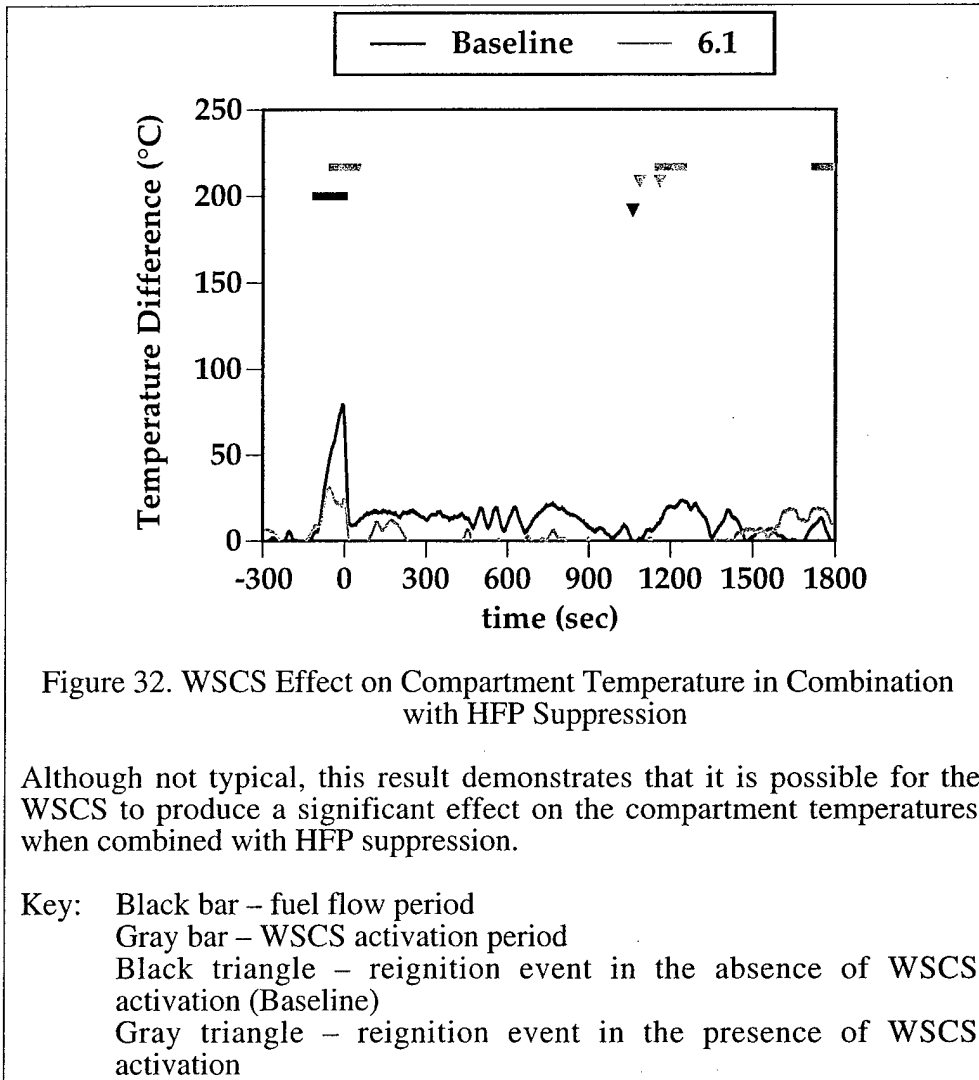

Figure 32. WSCS Effect on Compartment Temperature in Combination with HFP Suppression

Although not typical, this result demonstrates that it is possible for the WSCS to produce a significant effect on the compartment temperatures when combined with HFP suppression.

- Key:
- Black bar – fuel flow period
 - Gray bar – WSCS activation period
 - Black triangle – re-ignition event in the absence of WSCS activation (Baseline)
 - Gray triangle – re-ignition event in the presence of WSCS activation

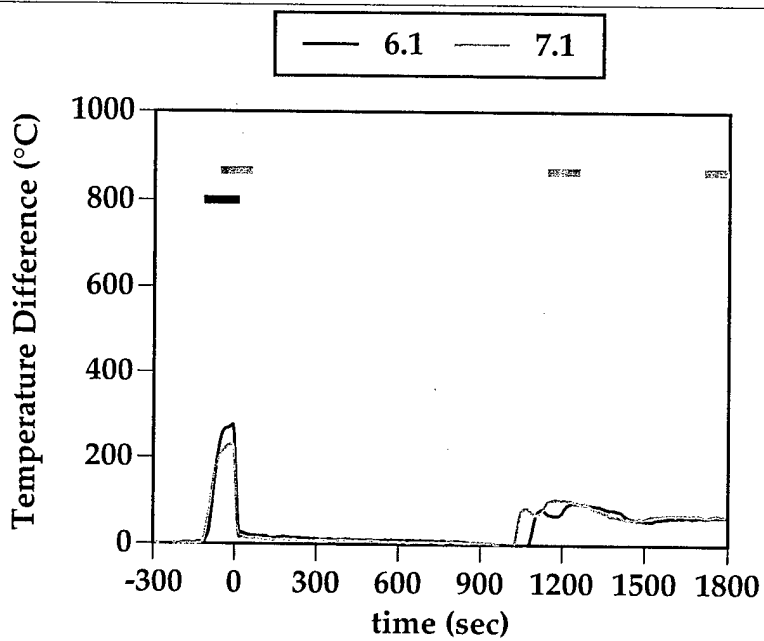

Figure 33. Effects of Reduced WSCS Flow Rate on Plume Temperature

Test 7.1 was identical to 6.1, except that the WSCS flow rate was reduced from 0.29 l/s to 0.18 l/s.

Key: Black bar – fuel flow period
 Gray bar – WSCS activation period

These preliminary results have shown that the effectiveness of the WSCS is dependent on, at least, the following parameters:

- a. the size of the fire at the time that the WSCS is activated;
- b. the duration of the WSCS application;
- c. the WSCS flow rate and droplet size distribution; and
- d. whether the WSCS application overlaps the HFP discharge.

Although some trends have been observed, the relative importance of the above factors is poorly understood, at present. In order to obtain the information needed for design of actual systems, it is important that each of the above factors be investigated systematically. Any such research program must provide sufficient replicate tests to permit valid statistical analyses to be conducted.

6.0 RECOMMENDATIONS

It is important to reiterate that the tests discussed in this report were not intended to produce specific recommendations regarding WSCS design parameters or operational doctrine but rather to explore the novel WSCS approach. However, the data obtained do provide insights useful for designing a definitive test program that will produce engineering and operational guidance.

Probably the greatest limitation of the work described in this report is the limited scope of the tests. For the next phase of the WSCS program, it is necessary to design a test program with sufficient replicate experiments to permit statistical analysis. It will then be possible to state with certainty how much of an effect the WSCS has under any given circumstances.

6.1 Operational Considerations for the WSCS

The WSCS can provide benefits via three mechanisms:

- a. cooling;
- b. weakening of the fire (less HF generated); and
- c. scrubbing of the HF produced.

In addition to its obvious effect on habitability, compartment cooling is an important factor in lowering the probability of reignition and may significantly reduce the production of toxic gases, especially HF. Scrubbing further improves habitability by removing soot, HF and other toxins. It is suggested that future engineering studies of the WSCS concept be directed toward improved understanding of the ways in which WSCS affects each of these two mechanisms.

Reignition is a particularly important phenomenon because it negates the previous progress in extinguishment, cooling and scrubbing. It is useful to consider reignitions that occur during the hold period separately from those that occur during ventilation. Although the mechanisms involved are the same, the operational impacts can be very different.

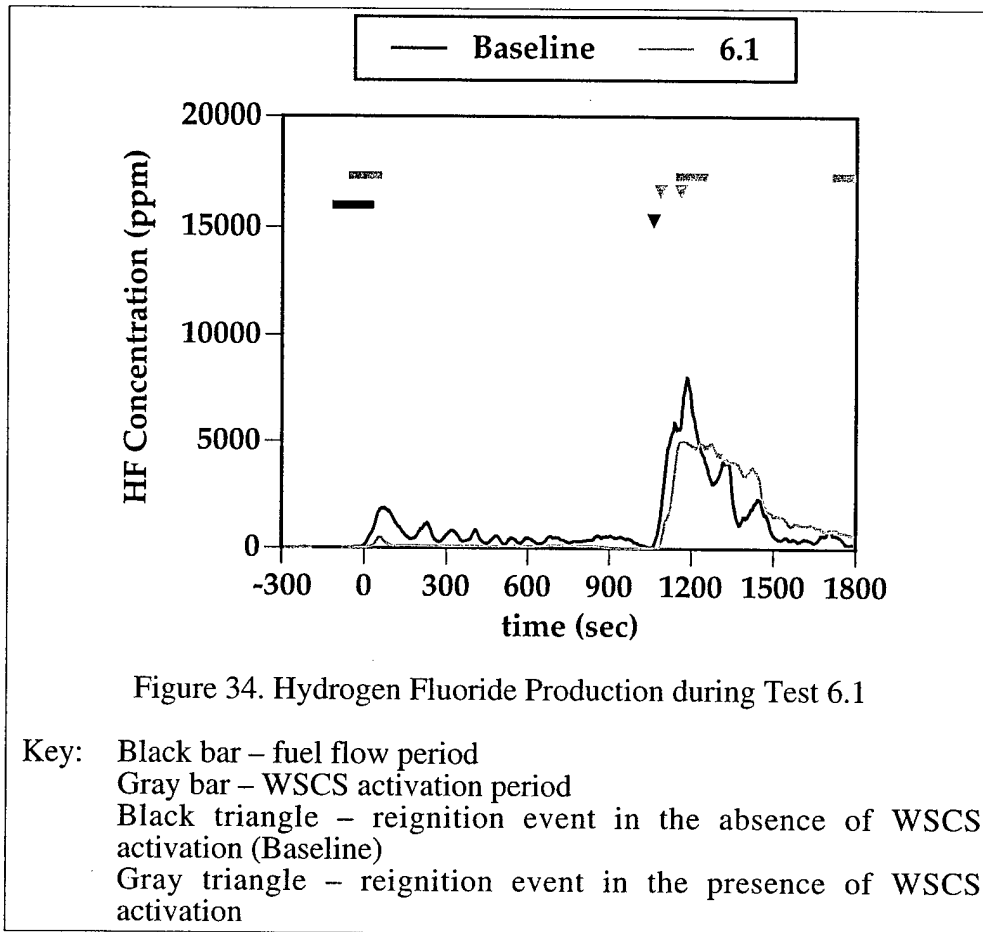

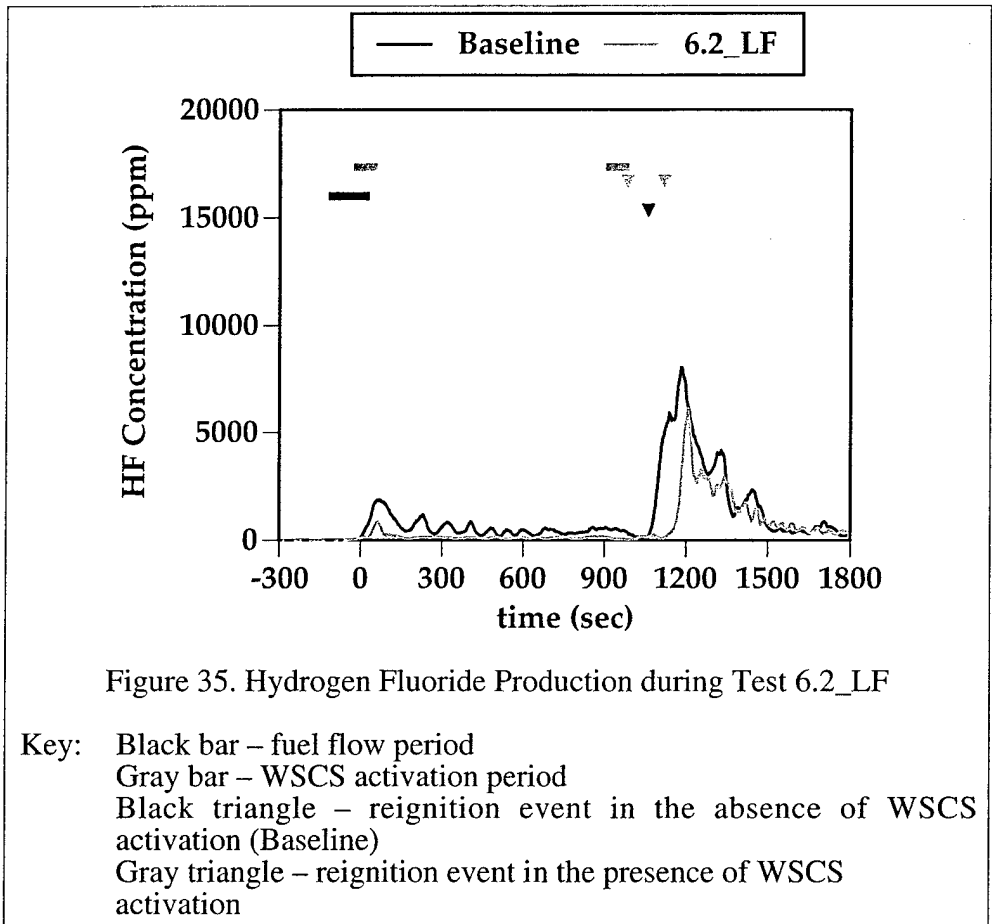

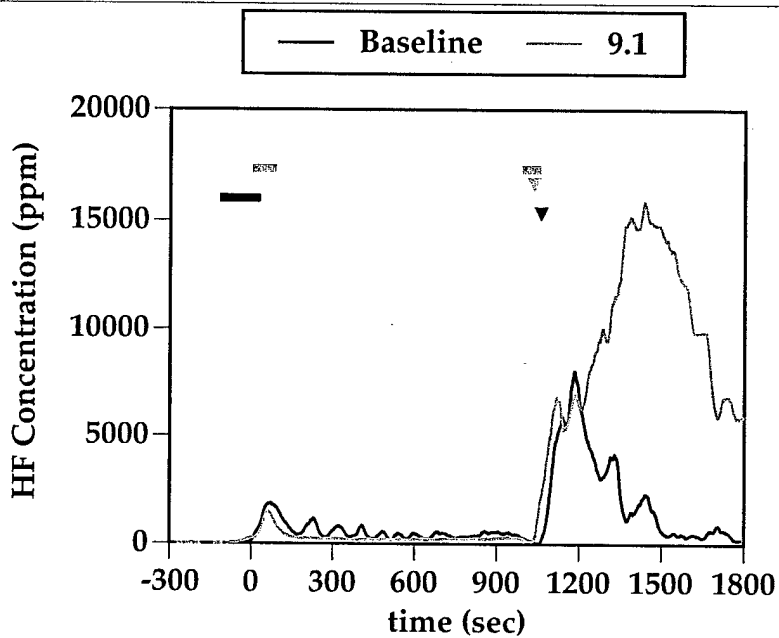
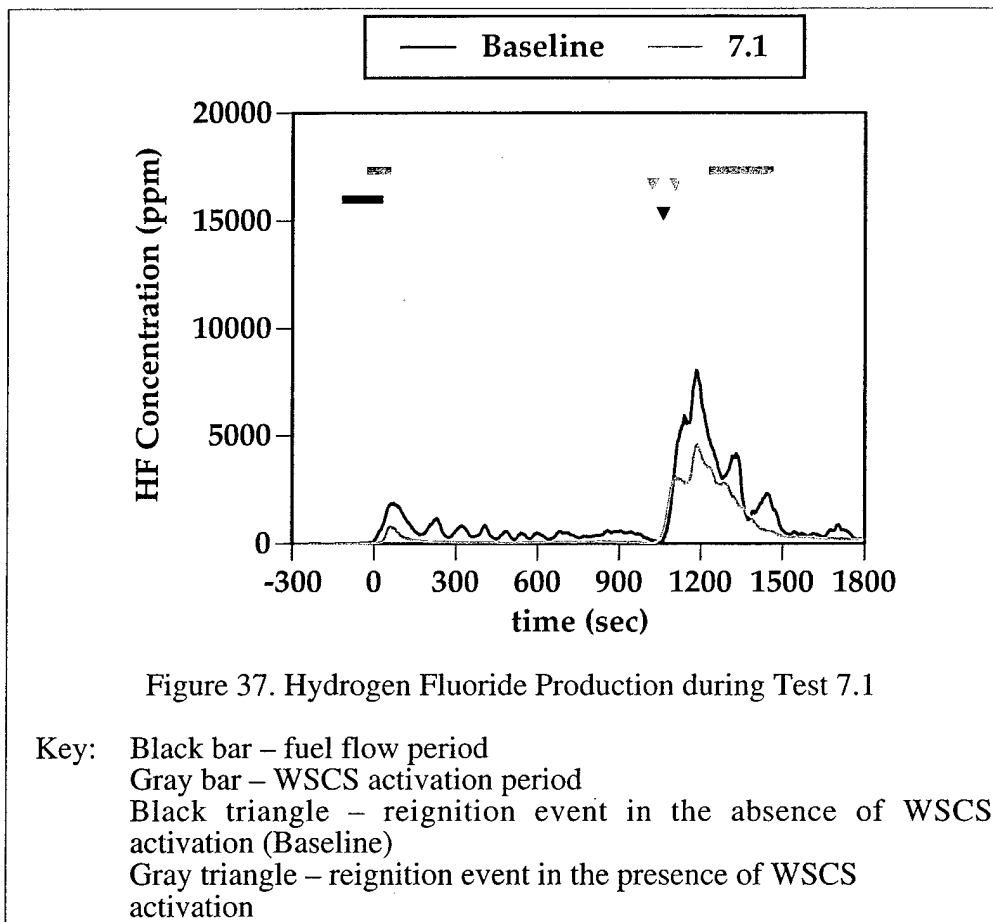

Figure 36. Hydrogen Fluoride Production during Test 9.1

Key: Black bar – fuel flow period
 Gray bar – WSCS activation period
 Black triangle – reignition event in the absence of WSCS activation (Baseline)
 Gray triangle – reignition event in the presence of WSCS activation



The hold period is, by definition, that interval in which the agent concentration is continuously maintained above the critical level required for extinguishment. During this period, there may be regions where the agent concentration is below the threshold and reignitions can occur, but any such reflashes will be localized events. Also, when a reignition does occur, the induced flows typically mix additional agent into the low concentration region and extinguish the fire. Thus, hold-period reflashes tend to be small and self-limiting and, consequently, they have negligible effects on compartment temperatures or HF concentrations.

During the ventilation period the agent is systematically being diluted and, at some point, the mean agent concentration will fall below the critical level. Compartment-wide reignition events then become possible and they will not be self-extinguishing. The impact on compartment temperature can be very significant. Further, since the agent concentration may still be significant (although below that needed for effective suppression), there may be copious HF production (see Figures 34 - 37).

In order to optimize the design of the WSCS, the effects of the system, when used during both the hold and venting periods, must be explored in more detail.

6.2 Investigation of WSCS Thermal Effects

As mentioned above, compartment cooling is itself a significant benefit of the WSCS; it is also one of the keys to preventing reflashes and to reducing further production of toxic gases. After the compartment has been cooled below the ignition temperature for the available fuels, the reflash potential will be near zero⁵.

The evidence at hand suggests, as we would intuitively expect, that rapid activation of the WSCS provides the greatest cooling effect. In particular, the WSCS is very effective in limiting thermal insult when used against an unsuppressed fire. Thus, it is reasonable to hypothesize that, for cooling, the best use of the WSCS may be in the period prior to activation of the suppression system — in other words, during the evacuation interval between detection and suppression (Figure 20). To investigate this further, we suggest that the test protocols explicitly recognize the fire detection event and that realistic evacuation times be specified.

Tests would then involve a pre-burn period, simulating the growth of an undetected fire, followed by an alarm that marks the earliest time at which the WSCS could be activated. Various pre-burn times could be used to provide different threats for the WSCS. Of course, the length of pre-burn must be consistent with realistic shipboard circumstances. For example, a long pre-burn could reasonably occur in an unmanned space but is not likely in a manned space.

The WSCS was intended to operate from the ship's fire main and, in principle, could continue to run indefinitely. However, in practice, the duration of the WSCS activation may be constrained by concerns over flooding. Accordingly, for operational reasons, one Naval Sea Systems Command goal for a WSCS design would be to minimize the total volume of water required. We have seen that the WSCS is less effective in controlling temperature when it is used simultaneously with the fire extinguishing system. This suggests that future investigations of WSCS cooling effects should focus on the period between alarm and activation of the gaseous suppression system⁶.

The effects of WSCS cooling during the hold and ventilation phases are also important for reflash control and for expediting reclamation. It seems reasonable to expect that continued application of water spray subsequent to extinguishment (*i.e.*, after the agent discharge has been

⁵ But not completely eliminated. Electrical reignition would still be possible.

⁶ However, for HF reduction, application of the WSCS after the gaseous agent discharge may be important.

secured), but before ventilation is resumed, might lower the compartment temperatures enough to reduce the potential for reignition. Therefore, a systematic study of the effects of the WSCS at different times during the hold phase should be undertaken.

Limiting the total volume of water used by the WSCS can be accomplished by reducing either the application rate or the application duration, or both. The test program should compare the effects of intense, short-term applications with those of lower flow rates over an extended time, perhaps for the entire duration between alarm and agent discharge or between extinguishment and ventilation. In addition, the use of multiple WSCS bursts, spaced at relatively long intervals, should also be considered as an option.

The limited testing to date has shown slightly greater temperature reductions with a lower WSCS application rate (tests 6.1 and 7.1). This suggests that flow rate may be a less important parameter than activation time and activation duration, at least for flows in the limited range used to date. However, we should note that, in these tests, the water droplet size distribution also varied with the application rate so the effects of droplet size and flow rate could not be separated. Both parameters need to be investigated more systematically and over wider ranges.

6.3 Investigation of WSCS HF Reduction Effects

There is clear evidence that extinguishment phase HF concentrations are lower when the WSCS is used than when it is not used. This is due to a combination of reduction in the production of HF and scrubbing of that which is produced. In order to investigate these effects, it will be necessary to systematically study the interaction of the WSCS and gaseous agent suppression systems. Furthermore, the WSCS reduces the risk and intensity of reignitions, therefore, limiting or eliminating HF production during reflashes.

There are two concerns with the currently available HF data. First, due to instrumentation difficulties, there was not as much data as planned for comparisons between tests. This could be addressed either by improving the reliability of the existing CAAs, adding more CAAs to provide redundancy or by switching to different, more reliable, analyzers.

Secondly, the HF concentrations were not well controlled during these experiments. In order to obtain reproducible measurements of the WSCS scrubbing effects, it will be important to control the production of the HF in a reproducible manner.

By inhibiting the growth of the fire during the evacuation phase, the WSCS may reduce the size of the fire that must be suppressed during the extinguishment phase, leading to reduced production of HF. However, based on our observations, it appears that the greatest effect of HF inhibition will be seen during the ventilation phase, when the potential for reflash is highest. Therefore, it is important to design tests to investigate the interactions between the WSCS system and the reignition events.

In addition to studies of the effects of WSCS on HF production, systematic tests should be conducted, under conditions simulating the hold period, to investigate HF scrubbing as a function of WSCS operating conditions. The primary parameters to be considered are the WSCS application rates, application times and droplet size distributions. The use of intermittent WSCS applications should also be investigated.

7.0 ACKNOWLEDGMENTS

We wish to thank the many people who participated in the FLSR 1 Halon Replacement Program tests conducted at CBD. Special thanks go to Howard Burchell, Roger Brown and Clarence

Whitehurst (NRL), to Philip Gunning and Scott Duffy (both of whom were WPI graduate students at the time this work was performed) and to Ron Wilson (MPR Associates).

8.0 REFERENCES

1. "Halon 1301 Replacement Total Flooding Fire Testing, Intermediate Scale," R. S. Sheinson, H. G. Eaton, B. H Black. R. Brown, H. Burchell, A. Maranghides, C. Mitchell, G. Salmon, and W. D. Smith, Proceedings of the Halon Options Technical Working Conference, Albuquerque, NM, pp. 43-53, May 3-5, 1994.
2. "Large Scale (840 m³) HFC Total Flooding Fire Extinguishment Results," R. S. Sheinson, A. Maranghides, H. G. Eaton, D. Baryliski, B. H Black. R. Brown, H. Burchell, P. Byrne, T. Friderichs, C. Mitchell, M. Peatross, G. Salmon, W. D. Smith and F. W. Williams, Proceedings of the Halon Options Technical Working Conference, Albuquerque, NM, pp. 637-648, May 9-11, 1995.
3. "Intermediate (56 m³) and Full Scale (840 m³) HFC Total Flooding Fire Extinguishment Results," R. S. Sheinson, A. Maranghides, D. Baryliski, B. H Black. R. Brown, H. Burchell, P. Byrne, H. G. Eaton, T. Friderichs, C. Mitchell, M. Peatross, G. Salmon, W. D. Smith and F. W. Williams, INTERFLAM '96, St. John's College, Cambridge, England, pp. 901-906, March 26-28, 1996.
4. "Water Spray Cooling System — A Gaseous Suppression System," A. Maranghides, R. S. Sheinson, B. A. Williams and B. H Black. INTERFLAM '96, Edinburgh, Scotland, pp. 627 - 637, June 19 - July 1, 1999.
5. "Water Spray Cooling System for Extinguishment and Post Fire Suppression of Compartment Fires," R. S. Sheinson and A. Maranghides, United States Patent 5918680, July 6, 1999.

Appendix A
Temperature Comparisons for Group 1 Tests

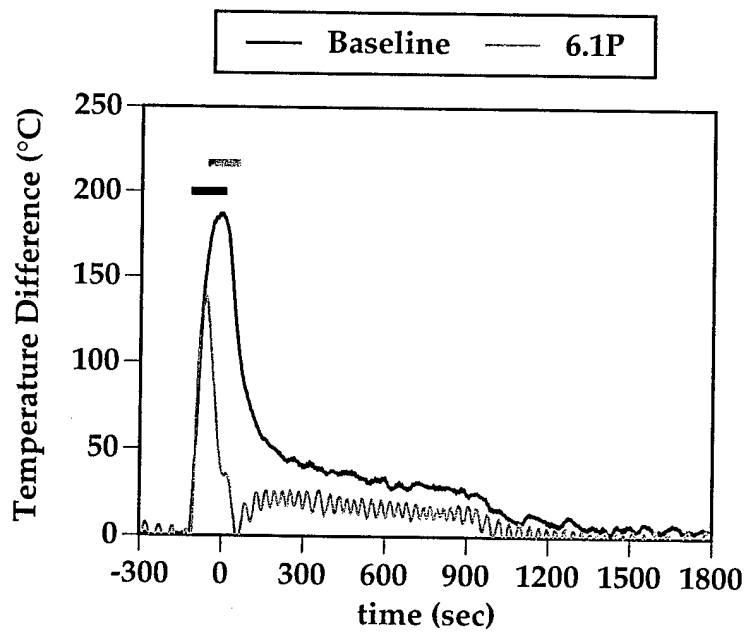
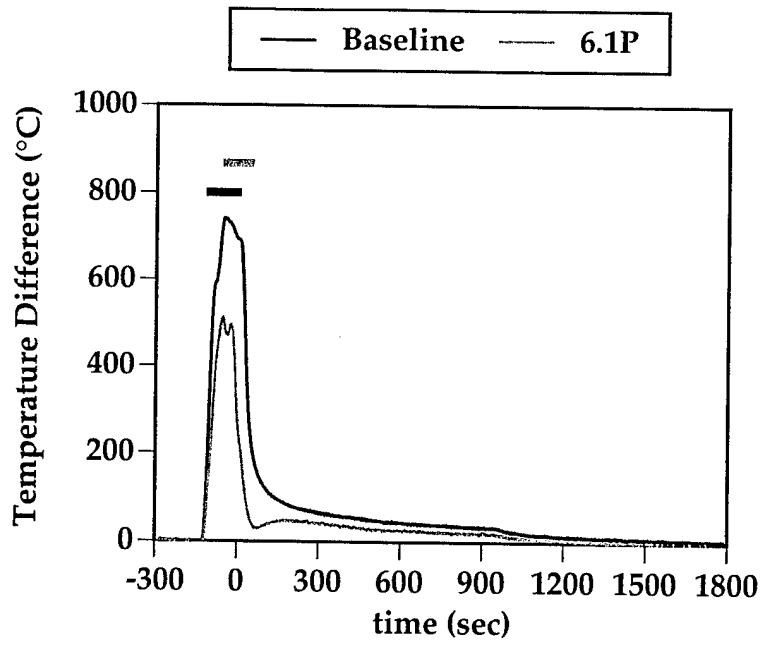

Figure A-1. Fire Plume and Compartment Temperatures vs. Baseline for Test 6.1P (Subgroup A)

Temperatures are from the 2.67 m thermocouples of Tree 1 (upper) and Tree 3 (lower).

Key: Black bar – fuel flow period
 Gray bar – WSCS activation period

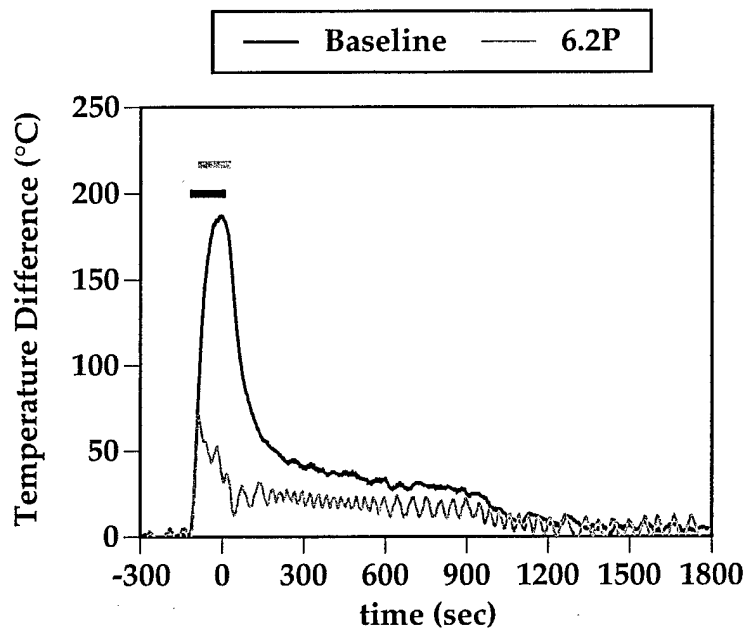
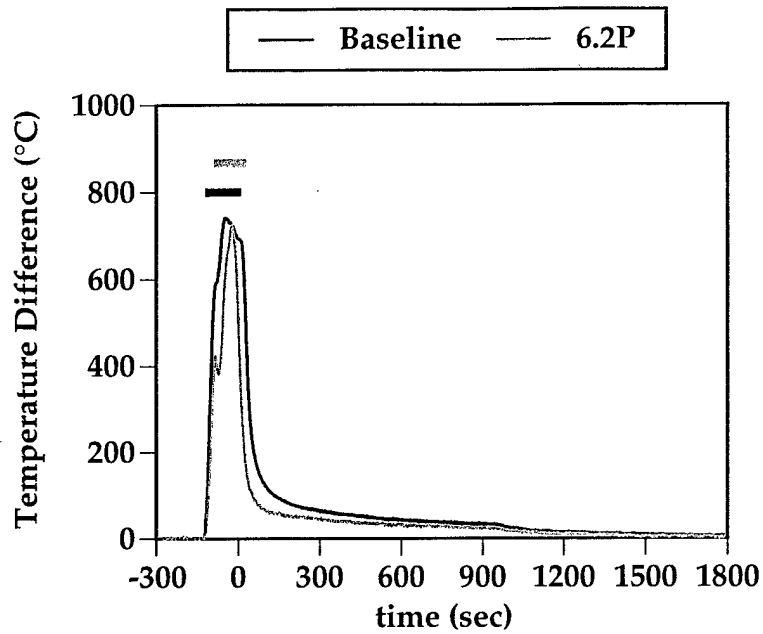

Figure A-2. Fire Plume and Compartment Temperatures for Test 6.2P vs. Baseline (Subgroup A)

Temperatures are from the 2.67 m thermocouples of Tree 1 (upper) and Tree 3 (lower).

Key: Black bar – fuel flow period
 Gray bar – WSCS activation period

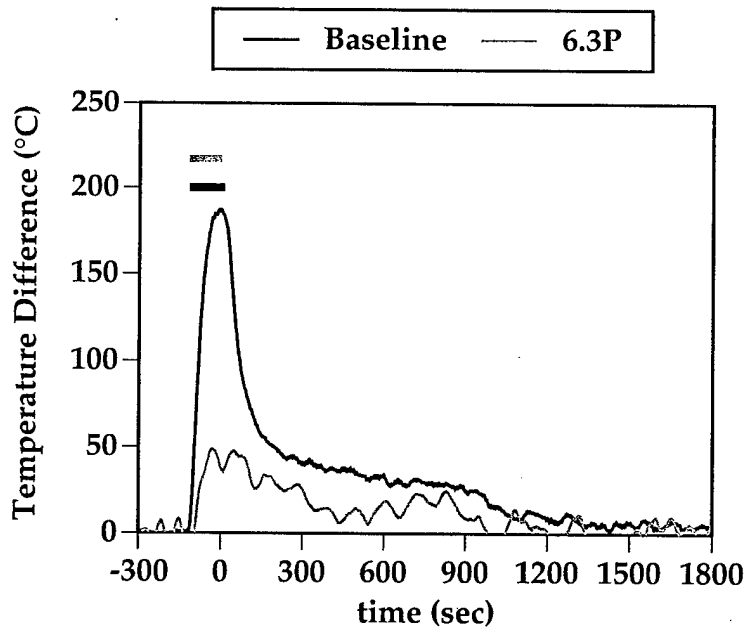
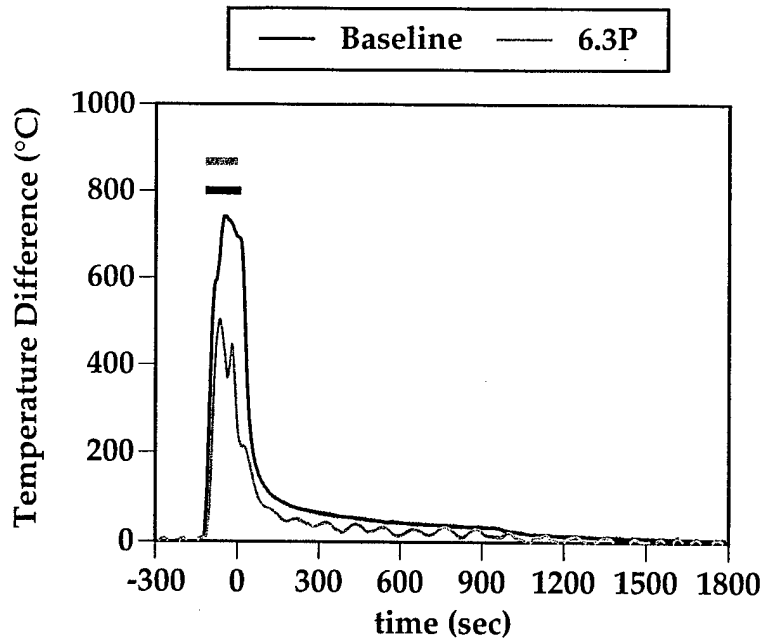

Figure A-3. Fire Plume and Compartment Temperatures for Test 6.3P vs. Baseline (Subgroup A)

Temperatures are from the 2.67 m thermocouples of Tree 1 (upper) and Tree 3 (lower).

Key: Black bar – fuel flow period
 Gray bar – WSCS activation period

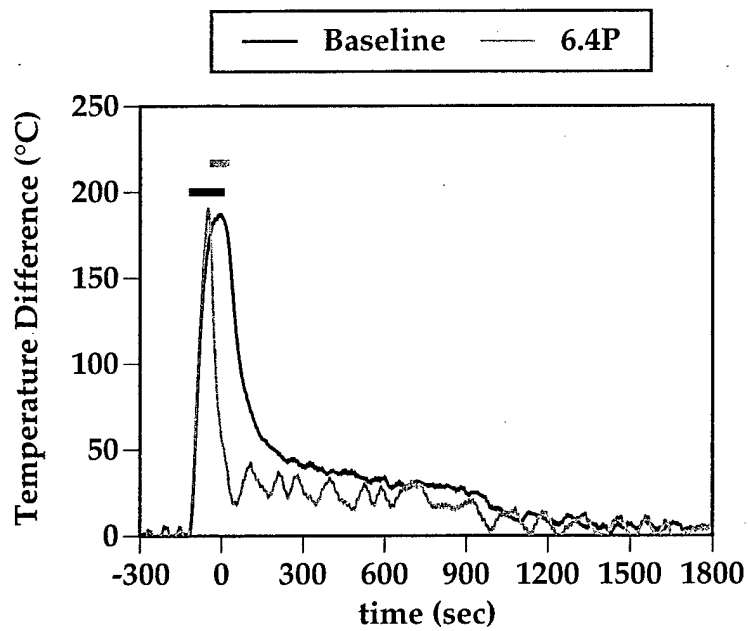
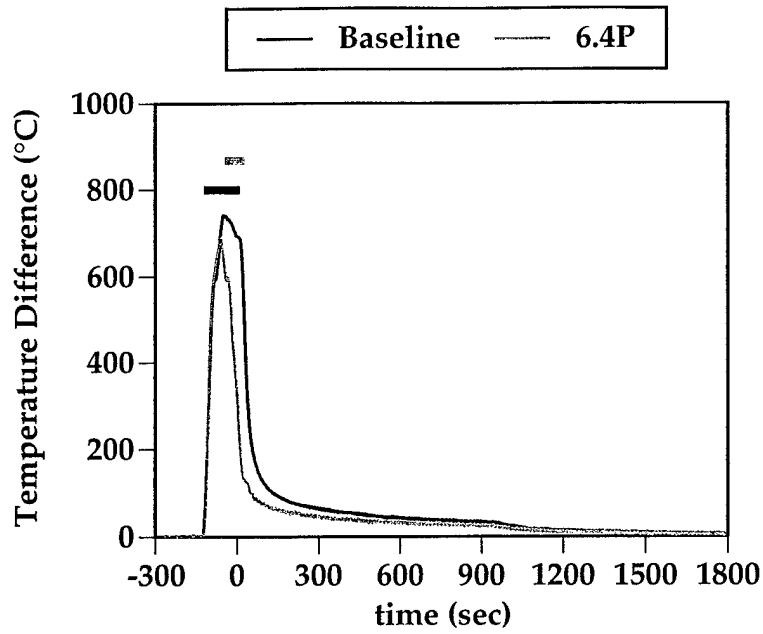

Figure A-4. Fire Plume and Compartment Temperatures for Test 6.4P vs. Baseline (Subgroup B)

Temperatures are from the 2.67 m thermocouples of Tree 1 (upper) and Tree 3 (lower).

Key: Black bar – fuel flow period
 Gray bar – WSCS activation period

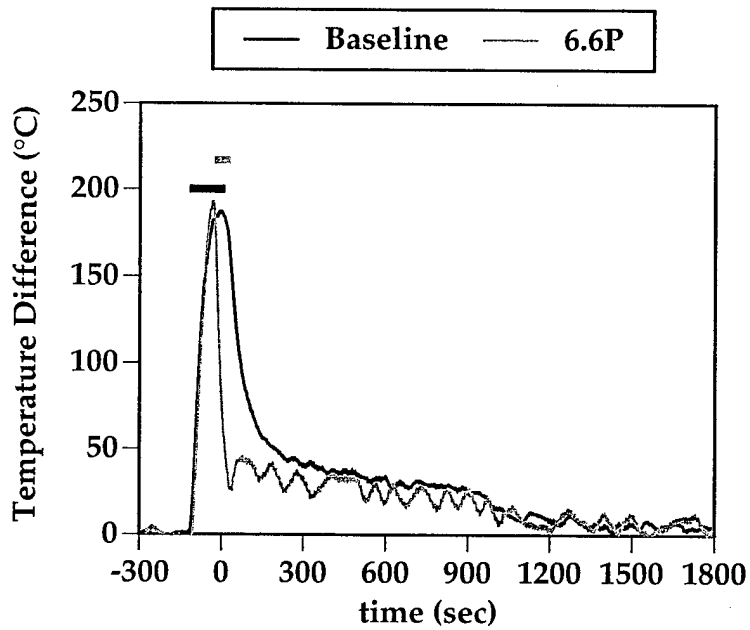
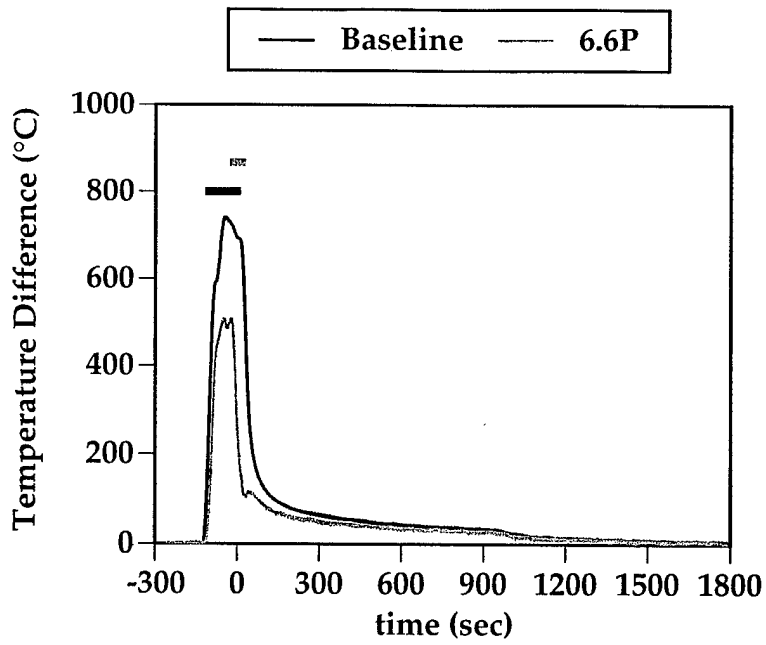

Figure A-5. Fire Plume and Compartment Temperatures for Test 6.6P vs. Baseline (Subgroup B)

Temperatures are from the 2.67 m thermocouples of Tree 1 (upper) and Tree 3 (lower).

Key: Black bar – fuel flow period
 Gray bar – WSCS activation period

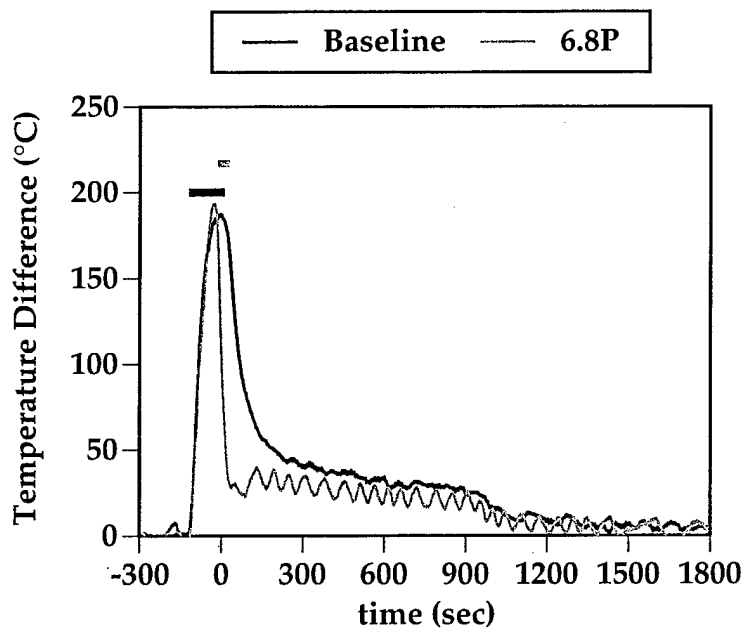
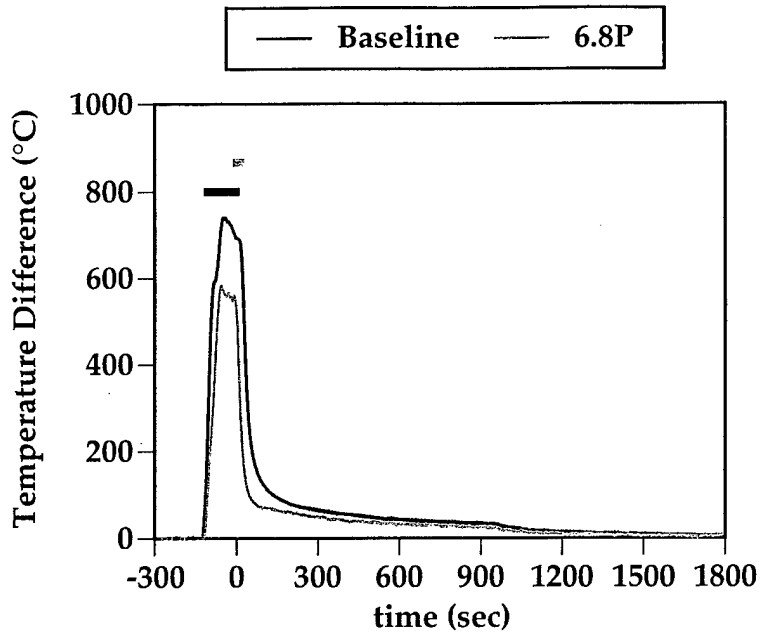

Figure A-6. Fire Plume and Compartment Temperatures for Test 6.8P vs. Baseline (Subgroup B)

Temperatures are from the 2.67 m thermocouples of Tree 1 (upper) and Tree 3 (lower).

Key: Black bar – fuel flow period
 Gray bar – WSCS activation period

Appendix B

Temperature and HF Comparisons for Group 2 Tests

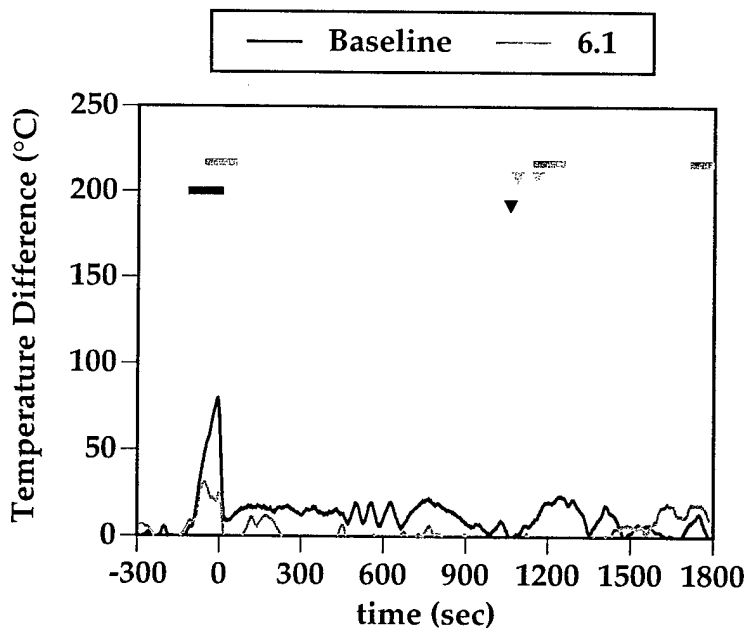
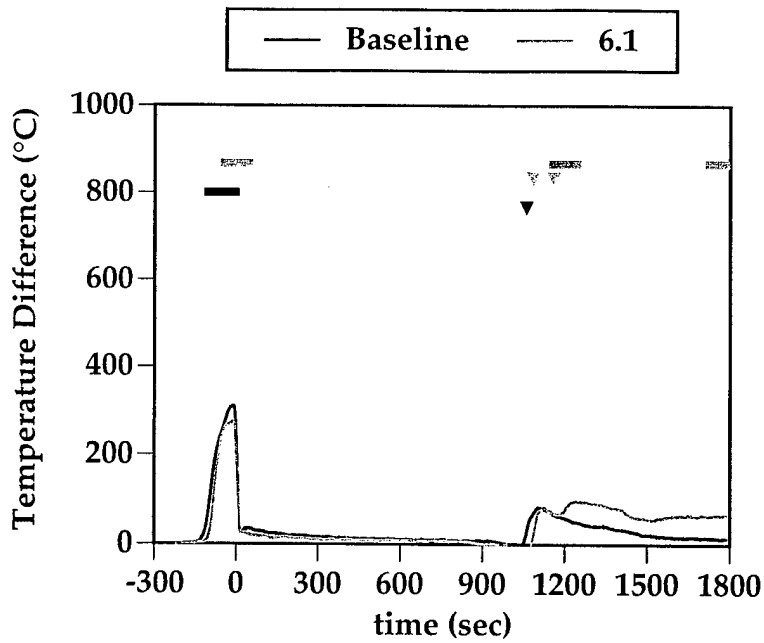

Figure B-1. Fire Plume and Compartment Temperatures vs. Baseline for Test 6.1

Temperatures are from the 2.67 m thermocouples of Tree 1 (upper) and Tree 3 (lower).

- Key:
- Black bar – fuel flow period
 - Gray bar – WSCS activation period
 - Black triangle – reignition event in the absence of WSCS activation (Baseline)
 - Gray triangle – reignition event in the presence of WSCS activation

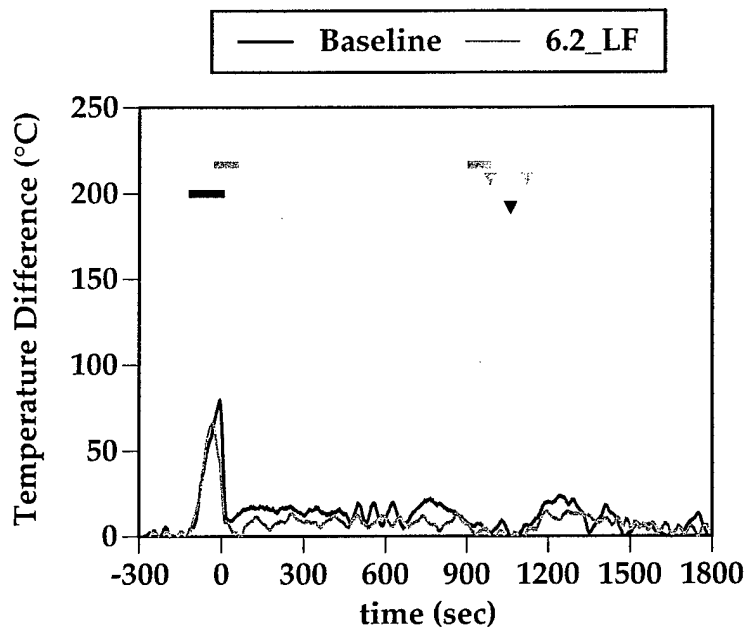
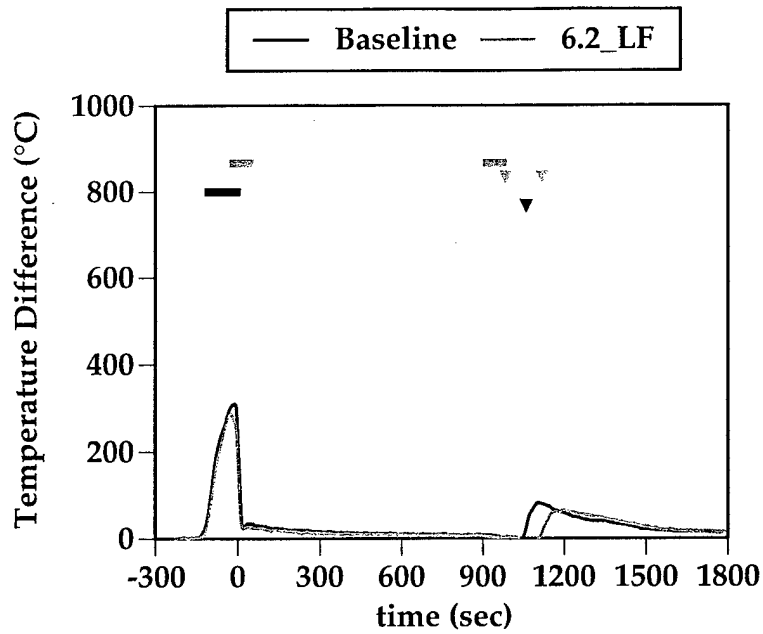

Figure B-2. Fire Plume and Compartment Temperatures vs. Baseline for Test 6.2_LF

Temperatures are from the 2.67 m thermocouples of Tree 1 (upper) and Tree 3 (lower).

- Key:
- Black bar – fuel flow period
 - Gray bar – WSCS activation period
 - Black triangle – reignition event in the absence of WSCS activation (Baseline)
 - Gray triangle – reignition event in the presence of WSCS activation

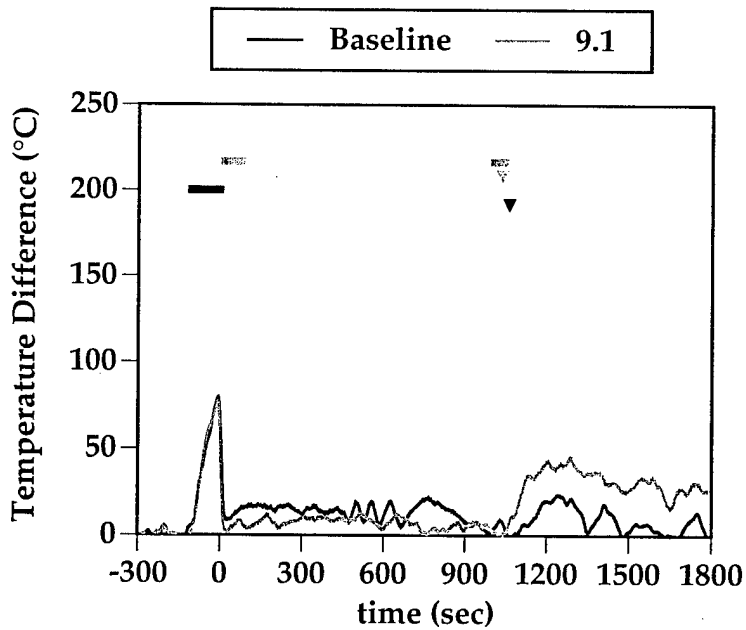
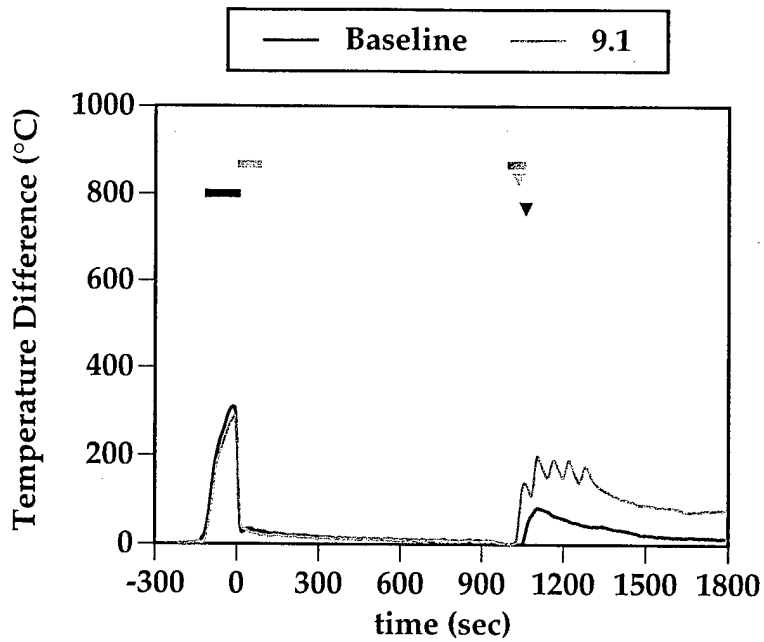

Figure B-3. Fire Plume and Compartment Temperatures vs. Baseline for Test 9.1

Temperatures are from the 2.67 m thermocouples of Tree 1 (upper) and Tree 3 (lower).

- Key:
- Black bar – fuel flow period
 - Gray bar – WSCS activation period
 - Black triangle – reignition event in the absence of WSCS activation (Baseline)
 - Gray triangle – reignition event in the presence of WSCS activation

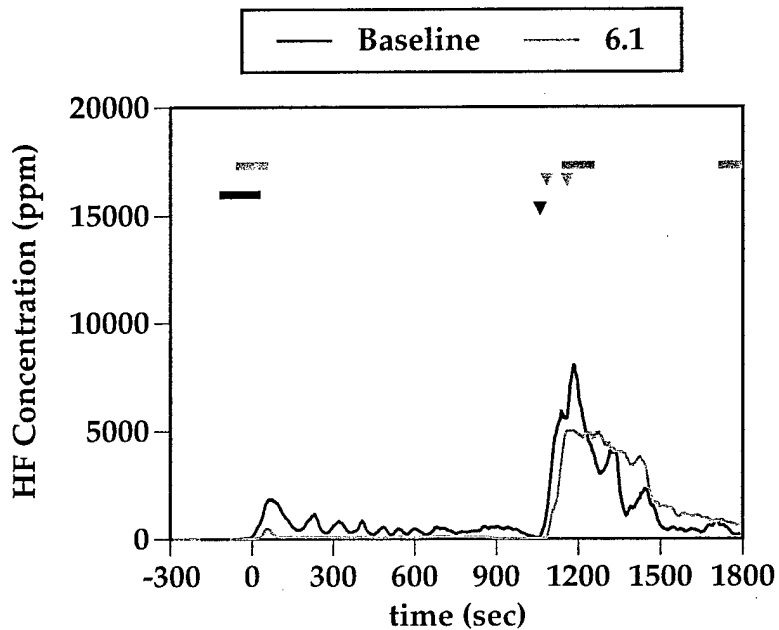

Figure B-4. Hydrogen Fluoride Concentrations vs. Baseline for Test 6.1

Concentrations are from CAA 5, which was located in the exhaust stack.

- Key:
- Black bar – fuel flow period
 - Gray bar – WSCS activation period
 - Black triangle – reignition event in the absence of WSCS activation (Baseline)
 - Gray triangle – reignition event in the presence of WSCS activation

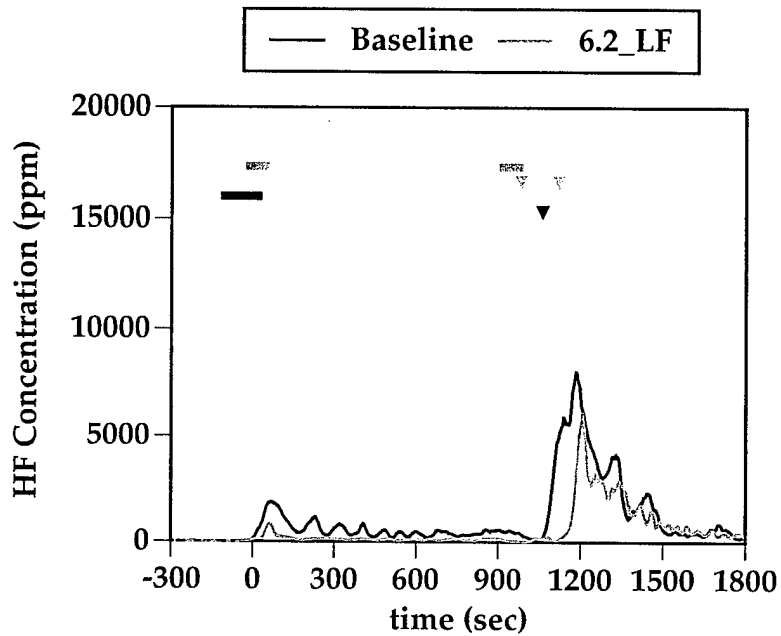

Figure B-5. Hydrogen Fluoride Concentrations vs. Baseline for Test 6.2_LF

Concentrations are from CAA 5, which was located in the exhaust stack.

- Key:
- Black bar – fuel flow period
 - Gray bar – WSCS activation period
 - Black triangle – reignition event in the absence of WSCS activation (Baseline)
 - Gray triangle – reignition event in the presence of WSCS activation

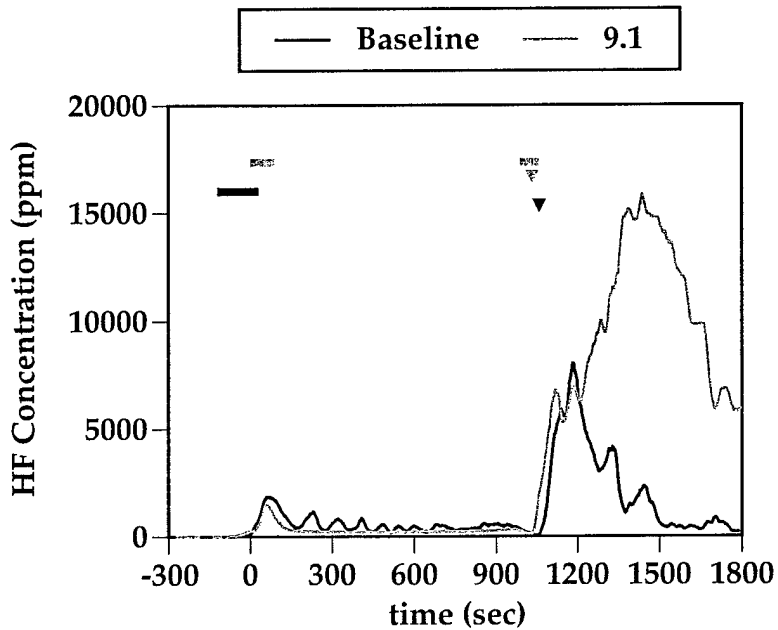

Figure B-6. Hydrogen Fluoride Concentrations vs. Baseline for Test 9.1

Concentrations are from CAA 5, which was located in the exhaust stack.

- Key:
- Black bar – fuel flow period
 - Gray bar – WSCS activation period
 - Black triangle – reignition event in the absence of WSCS activation (Baseline)
 - Gray triangle – reignition event in the presence of WSCS activation

Appendix C

Temperature and HF Comparisons for Group 5 Tests

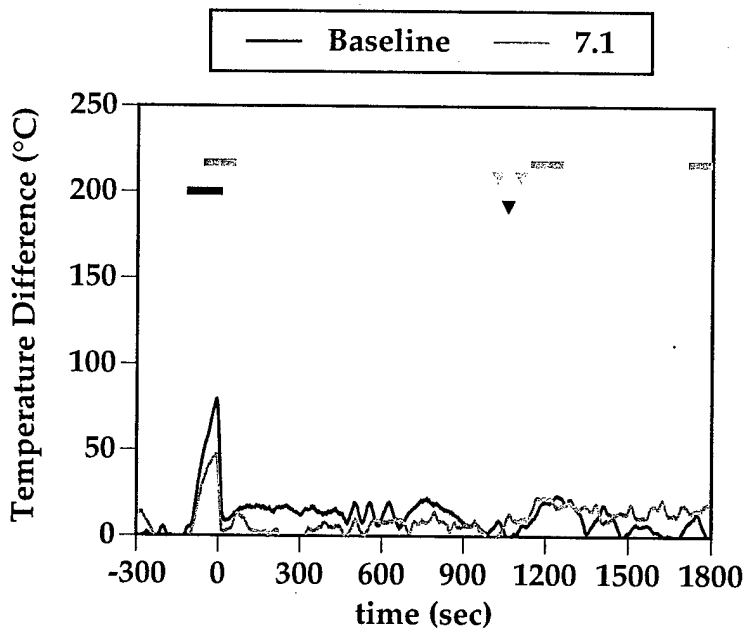
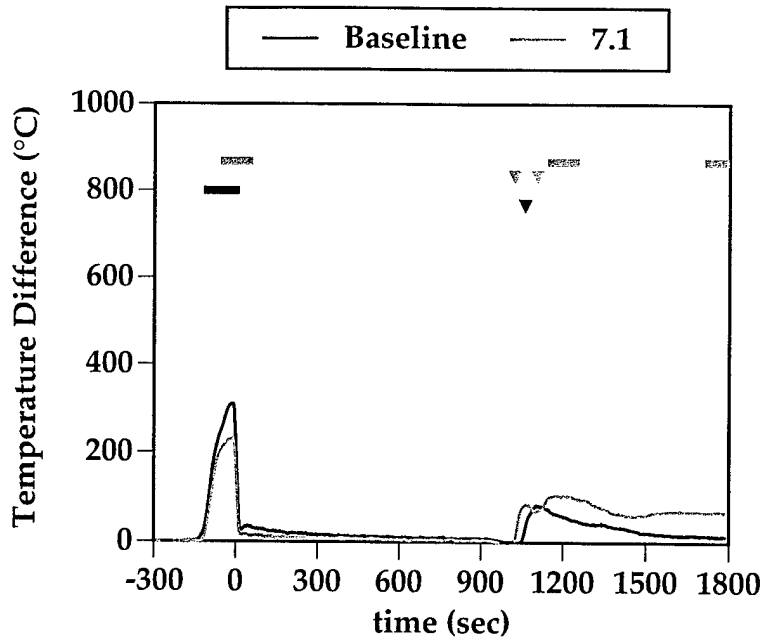

Figure C-1. Fire Plume and Compartment Temperatures for Test 7.1 vs. Baseline

Temperatures are from the 2.67 m thermocouples of Tree 1 (upper) and Tree 3 (lower).

- Key:
- Black bar – fuel flow period
 - Gray bar – WSCS activation period
 - Black triangle – reignition event in the absence of WSCS activation (Baseline)
 - Gray triangle – reignition event in the presence of WSCS activation

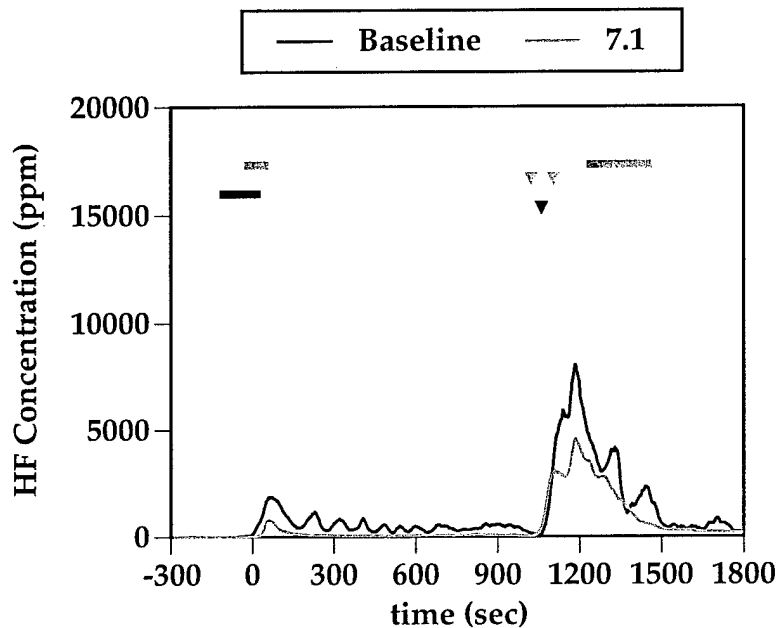

Figure C-2. Hydrogen Fluoride Concentrations for Test 7.1 vs. Baseline

Concentrations are from CAA 5, which was located in the exhaust stack.

- Key:
- Black bar – fuel flow period
 - Gray bar – WSCS activation period
 - Black triangle – reignition event in the absence of WSCS activation (Baseline)
 - Gray triangle – reignition event in the presence of WSCS activation