

NASA-TT-F-405 (Rev.)

D 2

NASA TECHNICAL
TRANSLATION

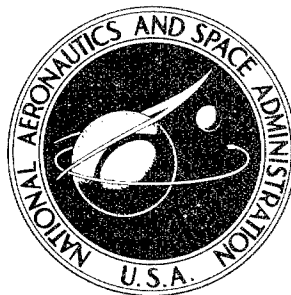

NASA TT F-405
REVISED

NASA TT F-405
REVISED

Corrected Copy

DISTRIBUTION STATEMENT A
Approved for Public Release
Distribution Unlimited

STREAMLINES IN A STEADY FLOW

by Robert Legendre

Reproduced From
Best Available Copy

From *La Recherche Aerospatiale*,
No. 105, 1965

20011011 101

NATIONAL AERONAUTICS AND SPACE ADMINISTRATION • WASHINGTON, D. C. • JULY 1966

LOVELACE FOUNDATION
DOCUMENT LIBRARY

307 1 1966

NASA TT F-405
(Revised)

STREAMLINES IN A STEADY FLOW

By Robert Legendre

Translation of "Lignes de courant d'un écoulement continu."
La Recherche Aéronautique,
No. 105, pp. 3-9, 1965

NATIONAL AERONAUTICS AND SPACE ADMINISTRATION

For sale by the Clearinghouse for Federal Scientific and Technical Information
Springfield, Virginia 22151 - Price \$1.00

STREAMLINES IN A STEADY FLOW

Robert Legendre

ABSTRACT

The author states some tentative principles in the absence of an existence theorem of sufficiently general solutions of viscous fluid equations which could be applied by engineers.

These principles are used for the characterization of the singular points of flow, which can be determined and identified by experimental engineers to solve a problem of fluid mechanics by a model.

Introduction

Theorems concerning the existence and uniqueness of solutions for the 3* three-dimensional flow problems of fluid mechanics are few in number, especially for viscous fluids. The conditions that must be satisfied within the fluid and with obstacles, so that there is a chance of insuring the existence and uniqueness of a solution with physical significance, are not even universally accepted, and serious mathematicians adopt rules for analyzing the local behavior which appear highly questionable to this author.

An existence and uniqueness theorem is not sufficient in any case. If there are no other methods for finding the solution, experimental results can be profitably used by engineers.

Unfortunately, observation of flows is not always easy and accurate. The effects caused by unavoidable turbulence, by vibrations at the obstacle, by roughness, are certain to modify the processes. The engineer tries to draw from the random variables, which are not useful in any way, a corresponding schematic approach equivalent to a well-formulated mathematical problem, with initial and boundary conditions simplified by eliminating the random variables.

*Numbers given in the margin indicate the pagination in the original foreign text.

I. Preliminary Principles

Since rigorous proofs are not yet available, reasonable principles are usually postulated, which are heuristically justified by the effectiveness of the predictions they establish.

A first principle, apparently universally admitted, is the following one:

The solution to the problem of viscous fluid flow, whose existence is experimentally proved, satisfies the Navier-Stokes equation. It is analytic inside the fluid, even if the initial and boundary conditions are not analytic. This means that components u , v , w , of the velocity, pressure p , specific mass ρ and temperature T are all analytic functions of coordinates x , y , z and time t .

The model sought by engineers can destroy this analytic quality at certain points or even on certain lines of surfaces, but it continues to exist almost everywhere. Singularities are nearly always sources of streamlines and, in many practical problems, the streamline source is a single one, located at infinity. The solution is then analytic at any point at a finite distance inside the fluid.

A second principle, apparently less universally admitted, concerns fluid behavior near obstacles. The author prefers to restrict his statement by considering only obstacles which have an analytic definition almost everywhere.

The solution to viscous fluid flow is analytic in the neighborhood of any analytic obstacle region (ref. 1).

The principle excludes the possibility of having velocity vary as a non-integral power of the distance to the obstacles. This is, however, sometimes used in certain local analyses and does not raise any contradiction. According to this author's intuition it has, however, no application to the physical problems of interest to engineers. It seems that in all cases where an existence and uniqueness theorem was established, the condition that the solution satisfy these two statements was imposed.

These two principles are not applied to perfect fluid flow; they are accessible, however, as limits to viscous fluid flows, when viscosity and conductivity go to zero. The analytic quality exists in general inside the fluid, except on a few lines such as vortex axes of the ideal incompressible fluids, or on a few surfaces such as vortex sheets and shock waves. The removal of the adherence condition, which is implicitly assumed for viscous fluids in the preceding sentences, upsets the conditions on the obstacles. The second principle remains valid here at the limit by a sort of substitution of the analytic quality at the boundary layer edge by the analytic quality at the wall. It is more difficult and unnecessary here to study the cases in which the special surfaces inside the perfect fluid are analytic. /4

The consequences to the two postulated principles will be developed only for steady flows. The engineer, for lack of better information, can apply the results to the description of the average streamline of a turbulent flow.

If the analytic quality of the solution to the viscous fluid equations is questioned, we note that the character of equivalence to a linear representation is the only one used.

II. Singular Flow Points

The streamlines of a flow are defined by the following differential equations

$$\frac{dx}{\rho u} = \frac{dy}{\rho v} = \frac{dz}{\rho w}$$

These equations are well determined from the above principles, except at the following locations

- the points where the velocity V , or rather ρV , is infinite; these points are considered streamline sources;
- at infinity, if there exists a streamline source at infinity;
- at the boundaries of the obstacle analytic domains;
- at the special points where ρu , ρv and ρw are simultaneously zero.

Only the neighborhood of these latter points will be considered, because the principles cannot be used near other points. Although there is no need here to have a complete discussion, which is the classic one of differential equations, it is useful to recall the essential conclusions of such a discussion.

As soon as the analytic quality is found around a singular point, taken as the origin, the streamlines are defined to within the second order by

$$\frac{dx}{a_{11}x + a_{12}y + a_{13}z} = \frac{dy}{a_{21}x + a_{22}y + a_{23}z} = \frac{dz}{a_{31}x + a_{32}y + a_{33}z}$$

where the denominators represent the principal parts of the flux vector $\rho \vec{V}$ components.

Degeneracy, which would bring the velocity to the second order, is not generally considered, because it can be studied as a consequence of merging of the singular points in practical problems, which depend almost always on parameters such as obstacle encounter. The adherence condition necessitates degeneracy around a singular obstacle point. In order to avoid a special study, the ratio of the velocity on the distance to the obstacle will be substituted for the velocity, and this ratio is of the first order, except when there is a new degeneracy.

The streamlines converging to a singular point are defined by

$$\frac{x}{a_{11}x + a_{12}y + a_{13}z} = \frac{y}{a_{21}x + a_{22}y + a_{23}z} = \frac{z}{a_{31}x + a_{32}y + a_{33}z} = \frac{1}{S}$$

where S is a solution of the equation

$$\begin{vmatrix} a_{11} - S & a_{12} & a_{13} \\ a_{21} & a_{22} - S & a_{23} \\ a_{31} & a_{32} & a_{33} - S \end{vmatrix} = 0.$$

The system can put in the form, provided the three roots S_1, S_2, S_3 are real

$$\frac{dX}{S_1 X} = \frac{dY}{S_2 Y} = \frac{dZ}{S_3 Z}$$

where X, Y, Z are linear forms in x, y, z, whose coefficients are minors of the determinant equation in S.

It is not possible to have all three roots of the same sign, because otherwise all streamlines would go through the singular point and ρV would be infinite at this point (according to the law of continuity). This does not necessarily mean that the existence of such a point in the flow must be eliminated; instead, we have a singular point which is considered a streamline source.

It is possible to narrow this result by using the continuity equation of fluid mechanics. We have, to within the second order

$$\text{div}(\rho \vec{V}) = a_{11} + a_{22} + a_{33} = S_1 + S_2 + S_3.$$

If there are no streamline sources, $\text{div} \rho \vec{V} = 0$ and the sum of the roots of the S equation is zero.

For a singular point on an obstacle we have

$$\text{div}(\rho \vec{V}) = (a_{11} + a_{22} + a_{33}) d + \rho \vec{V} \cdot \vec{D}d = 0$$

where d is the distance to the obstacle. Since $\rho \vec{V}$ tends to be orthogonal to $\vec{D}d$ the last term is of the second order, and the sum of the roots of the S equation remains zero.

One of the three roots, S_3 for example, is therefore of different sign from the other two. The streamlines form a node in the $Z = 0$ plane and saddle points in the planes $X = 0$ and $Y = 0$. The streamlines are more generally defined by

$$A X^{1/S_3} = B Y^{1/S_3} = C Z^{1/S_3}.$$

The projection of any streamline on the $X = 0$ plane, made parallel to the $Y = Z = 0$ line, is a streamline of the $X = 0$ plane to within the second order.

If only one root S_3 is real, the other two S_1 and S_2 are mutually conjugate, and so are the forms X and Y . The differential equations then are

$$\frac{d \ln Z}{S_3} = \frac{d \ln P^2}{2 S_1'} = \frac{d \theta}{S_1''}$$

for $X = P e^{i\theta}$ and $S_1 = S_1' + i S_1''$.

The streamlines are defined parametrically, always within the second order, by

$$Z = Z_1 e^{S_3 \theta / S_3'}, \quad P^2 = P_1^2 e^{2 S_1' \theta / S_1''}$$

where $\tan \theta$ is the ratio of the two linear forms in x, y, z and P^2 is a quadratic form of these variables.

In the $Z = 0$ plane corresponding to $Z_1 = 0$ the streamlines form a /5
focus. The projection of any streamline on the $Z = 0$ plane, made parallel to the real straight line $X = Y = 0$ is, to within the second order, a streamline of the $Z = 0$ plane. In space this line winds into a spiral around the streamline surface in the shape of a tulip.

It is not necessary here to discuss the numerous cases of secondary degeneracy when the components of ρV remain of the first order, possibly after dividing by the distance to an obstacle where the singular point is located. It is important, however, to note that

-- S_3, S_1' cannot be of the same sign because all streamlines would converge to the singular point where ρV would be infinite. The continuity equation entails that $S_3 + 2 S_1' = 0$;

-- if the two roots merge for special values of the problem parameters, an isotropic node, or isotropic focus, appears in the $Z = 0$ plane as a common degeneracy of the node and focus.

On the other hand, all regular streamline surfaces which go through the singular point are tangent to one of the planes $X = 0$, $Y = 0$ or $Z = 0$, and where the S equation has a single real root, they are tangent to $Z = 0$.

III. Flow Around a Slender Ogive

The preceding conclusions permit us to interpret the experimental result of Werlé (ref. 2), who used the same conclusions (ref. 3) regarding the flow behavior around a slender ogive.

The surface of the obstacle is regular and, if there is a singular point on it, the surface is tangent to one of the planes $X = 0$, $Y = 0$ or $Z = 0$ defined in the preceding section. The existence of a singular point on this obstacle is excluded if the scheme does not provide for a streamline source on it. The wall streamlines connect singular points which are nodes or foci. It is useful to consider here that the two streamlines which go through a saddle point do not terminate on this saddle point, but rather split and continue beyond. There are therefore at least two singular points of the node or focus type, and the existence of saddle points augments the number of these points.

There is no need to attempt to clarify this discussion, for example, by evoking the degeneracy of foci into centers, because it is generally impossible to deduce a complete description of the wall streamlines from the experimental results. The flow is a sufficiently unstable effect, downstream of the obstacle, for the singular points in this region to be easily found and identified.

It is, however, important to give a good description of the streamlines upstream of the obstacle.

There exists a streamline inside the fluid which ends at the upstream stagnation point and which continues on the obstacle into an infinite number of lines, which form a node, and cover the whole obstacle region in the vicinity of the stagnation point.

This last remark requires some comments, because there are several publications which state that the wall streamlines continue inside the fluid on a surface. This error arises from an extrapolation of the facts observed in a few simple cases provoking a degeneracy. In planar flows the streamline surface made up by the cylindrical obstacle is, indeed, extended inside the fluid by a surface. However, such degeneracies must be considered exceptional, and it is practically impossible to have a resultant planar flow. A close examination shows that the line along which the obstacle cuts the streamline surface, which should continue the same line into the fluid, is in reality a wall streamline connecting the singular points distributed more or less at random, because here we have an imperfect planar flow. There are then several lines--and not a surface--extending the obstacle inside the fluid. We shall prove later that the obstacle is extended by a sheet in the vicinity of a saddle point.

Following this digression it is necessary to analyze in more details the flow around the stagnation point of a slender ogive located in an incoming flow.

The plane $Z = 0$ is tangent to the obstacle at the stagnation point, plane $Y = 0$ is the plane of symmetry of the flow and plane $X = 0$ is perpendicular to plane $Y = 0$, but is not generally perpendicular to plane $Z = 0$.

The streamlines form a saddle point in plane $Y = 0$ and in plane $Z = 0$, and this is fairly clearly shown by experiments, because the stagnation point is sufficiently stable and the boundary layer in its vicinity is thin.

The wall streamlines starting from the stagnation point A divide into three regions on either side of the symmetry plane $Y = 0$ (fig. 1). A first region supplies a focus C, and is bounded by two special streamlines II and III. The other two regions, on either side of the preceding one, contain streamlines which go toward singular points downstream, which the experiments of Werlé, mentioned above, could not locate or identify. They are bound by lines II or III and lines I or IV of the plane of symmetry $Y = 0$.

The vicinity of focus C is not easy to study, because the flow is not perfectly stable and the boundary layer is thick. It is, however, perfectly clear that the streamlines wind up in spirals around a special line inside the liquid which may be called the axis of viscous eddies, or, more commonly, by extrapolation from the term belonging to the perfect fluid, the axis of vortex. Its tangent in C corresponds to the real straight line made by the intersection of the two complex conjugates $X = Y = 0$ of the preceding section. This linearization by a limited expansion produced a straight line as the special line. This special curved line going through C extends the obstacle inside the fluid and has properties which generalize those belonging to the straight line of the preceding section.

The boundary wall lines II and III meet at a saddle point B and extend 6 into two lines V and VI, one ending at C and the other one extending downstream.

The vicinity of saddle point B is particularly difficult to observe because not only is the saddle point imperfectly fixed and imbedded in a thick boundary layer, but the velocity is of the second order in its vicinity. In

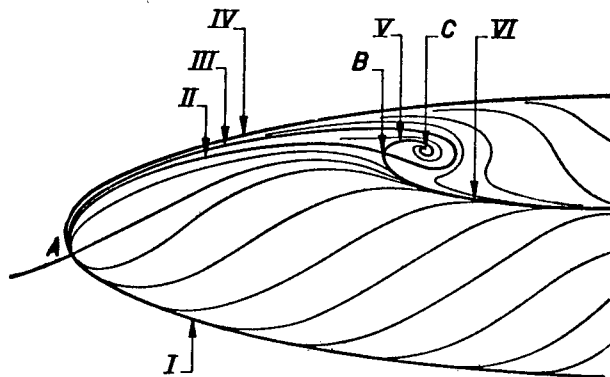

Figure 1. Wall flow on slender ogive.

addition, saddle point B is not very far from focus C. The following comments are based more on the considerations of the preceding section than they are deduced from the experiments. They could lead to more extended research which could either prove or disprove them.

Since a saddle point is observed in B, in the plane $Z = 0$ tangent to the obstacle, there must exist a saddle point and a node in the two planes $X = 0$ and $Y = 0$, tangent respectively to lines II and III and lines V and VI. It seems therefore that the node lies in this latter plane.

The streamlines inside the fluid go through the node and form a surface, which contains in particular lines V and VI, and consequently the vortex axis which goes through C. This surface was called the horn-type vortex sheet by Maurice Roy, in spite of the fact that it becomes a vortex sheet only for vanishing viscosities. It is a streamline surface extending the obstacle inside the fluid (fig. 2), or more exactly, extending the wall streamlines going through the saddle point into the fluid.

We still have to describe the behavior of the flow downstream. The streamlines originating from stagnation point A and directed downstream are deviated from lines I and IV of the plane of symmetry and come close to wall line VI. The behavior is as if lines I and IV were directed toward a saddle point and line VI toward a node. The Werlé experiments cited here were performed, however, on fairly short truncated ogives. Previously, experiments performed to verify the calculations of three-dimensional boundary layers by Eichelbrenner indicated the shape described above for flows around ellipsoids, in spite of the fact that the angle of attack was kept low in order not to have a focus.

The streamlines depart from, or come close to, the boundary lines very rapidly, and it is generally impossible to distinguish them from these boundaries all the way to the singular points. This has given rise to a minor error, which consists of taking the envelope of the wall streamlines as a boundary line. Another error, which is rather semantic, is to take the boundary as an asymptotic line to the wall streamlines. When a singular point is thrown to infinity, for example, on an infinite cylinder which is yawed, a generatrix is effectively an asymptote to the wall streamlines.

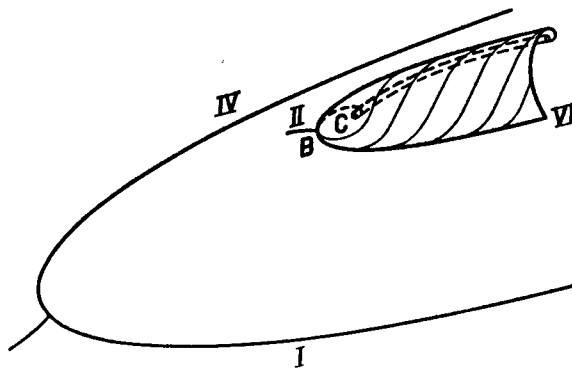

Figure 2. Horn-type of vortex sheet.

The shape of wall streamlines near a node permits us to estimate the ratio between the two roots of the equation in S dealing with the plane tangent to the obstacle. This observation shows that this ratio is generally very different from 1.

One last remark concerns the lack of correspondence between the boundary lines and the streamlines isolated into nodes. The boundary wall streamlines are those which go through the saddle points. When these lines come to nodes, they generally have no relationship to the streamline isolated at this node-- which has a local property. In the case of the slender ogive studied here, boundary lines II and III are distinct from the isolated line, whose tangent is perpendicular to the plane of symmetry and is osculating in the $X = 0$ plane. Boundary lines I and IV which go through downstream saddle points are planar by symmetry, in the special case, but this does not basically distinguish them, for local analysis, from the neighboring lines.

This interpretation goes beyond the conclusions of Werlé, who is an objective and careful experimenter, but who refused to recognize formally the model he was invited to prove or to disprove. We hope, however, that the observation will be geared to ideas based on logical reasoning, starting from preliminary but reasonable principles and going to usable empirical laws.

IV. Delta Wings

The effects present in the vicinity of delta wings, at angles of attack of from 10 to 20° , are analogous to those described concerning the flow around an ogive, provided that the leading edges and the apex are rounded.

Our interpretation is based on some unpublished results of Werlé concerning the flow around a delta wing with elliptical cross sections. The model was constructed for tests at low or zero angle of attack, to verify a pressure calculation by Guiraud and a calculation of three-dimensional boundary layers by Eichelbrenner. Some high angles of attack tests can be used for the subject of the present report, but bear on the leeward behavior (fig. 3).

Since the wing is relatively thick, focus C is very far downstream from saddle point B. The flow on the vortex sheet (left of fig. 3) is, however, difficult to distinguish. The flow near the trailing edge and in the downstream part of the leading edge is fuzzy and the lines shown in figure 3, which lead to a node at the wing extremity, are hypothetical, broadly speaking, since this extremity is singular. It is impossible to draw streamlines on the vortex sheet downstream of the trailing edge.

When the radius of curvature of the leading edge and the rounding of the apex are reduced, focus C, as is well known, and consequently saddle point B, will come toward the apex and merge with it. At the same time the stagnation point, located windward and not shown in figure 3, goes up toward the apex, even in the case of subsonic flow, and practically merges with the apex.

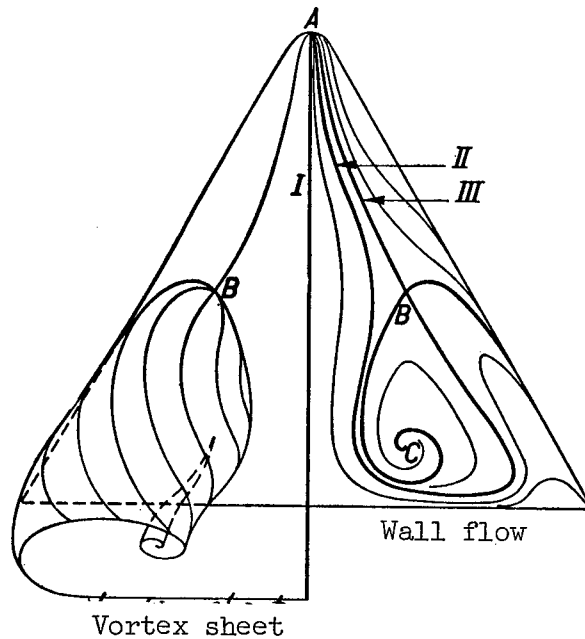

Figure 3. Flow around a delta wing of elliptical cross sections.

At the limit, for a plane delta wing (of negligible thickness) the flow is almost conical near the apex (ref. 4), as proved experimentally by Werlé upon request by the author (ref. 5). The streamline inside the fluid arrives at the stagnation point and merges, even in subsonic flow, with a semi-infinite straight line, whose inclination with the wing determines the angle of attack. This line is extended by the wing and the vortex surfaces.

It should be noted that the vortex surfaces become complicated. As the wing thickness diminishes, a second focus shows up among the wall streamlines, far downstream from the first focus. It also tends toward the apex when the thickness tends to zero. Experimental results for a precise description of intermediate phenomena are lacking, but the existence of secondary vortex sheets for the thin wing is well known. The study of this behavior does not follow directly the considerations of section II, since the limiting case considered corresponds to a systematic degeneracy of the flow, which becomes two-dimensional, and since the leading and trailing edges are sharp edges which are singular on the surface. It is, however, easy (but will not be done here) to deduce the properties of two-dimensional flows from the properties of three-dimensional flows, or, more simply, to understand the limit behavior of the flows studied above.

The outer wall streamlines (fig. 4) are distributed into four regions /8 on either side of the plane of symmetry. The boundary lines are semi-infinite straight lines originating from the apex. Lines I, III connect the saddle points at the apex, generalized to obstacles having singular lines, to nodes downstream. On the contrary, intermediate lines II and IV connect nodes at the

apex to saddle points downstream. Line V is crossed by streamlines which extend onto the principal vortex sheet.

The inner wall lines, not shown in figure 4, are divided only into two regions. Line VII connects a saddle point at the apex to a node downstream. Line VI connects a node at the apex to a saddle point downstream.

Every boundary line belongs to a stream surface which extends the obstacle inside the fluid.

In order to display the behavior of these surfaces better, we must use the two-dimensional property of the flow by studying the traces drawn by the conical stream surfaces on a sphere centered on the apex. We must project the sphere onto a plane tangent at a certain point, from the opposite point, which can be chosen to be situated on the extension of the bisector inside the wing, so that the trace drawn by the latter is a straight line.

For the case of subsonic flow--which alone is studied here--around the wing at an angle of attack but with no yaw, all projections thus obtained (fig. 5) originate from a node J, image of the upstream streamline inside the fluid going through the apex. They divide into four regions on either side of the plane of symmetry. These regions are bounded by five boundary lines, two of these regions being cut by the vortex surface projections.

The lines from the first region terminate at a node, trace of the wing bisector, on the extrados side. The lines from the second region terminate at a focus, trace of the secondary vortex axis. The lines from the third region terminate at a focus, trace of the principal vortex axis. The lines from the fourth region terminate at a node, trace of the wing bisector on the intrados side.

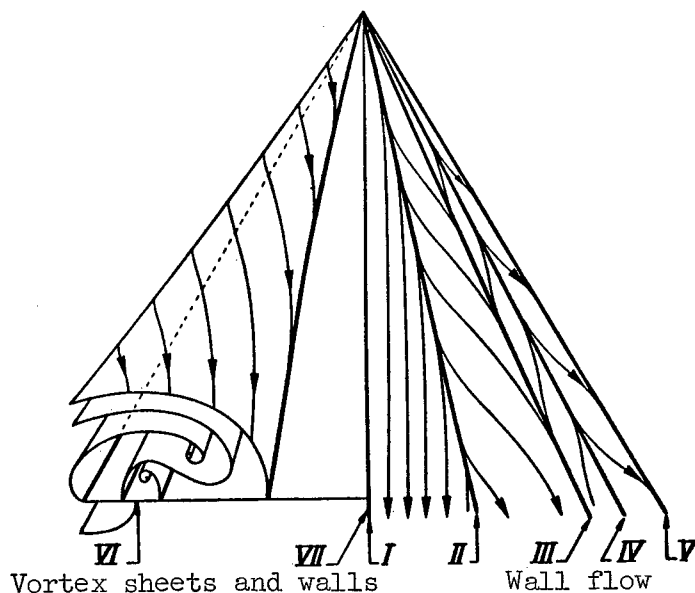

Figure 4. Flow around thin delta wing.

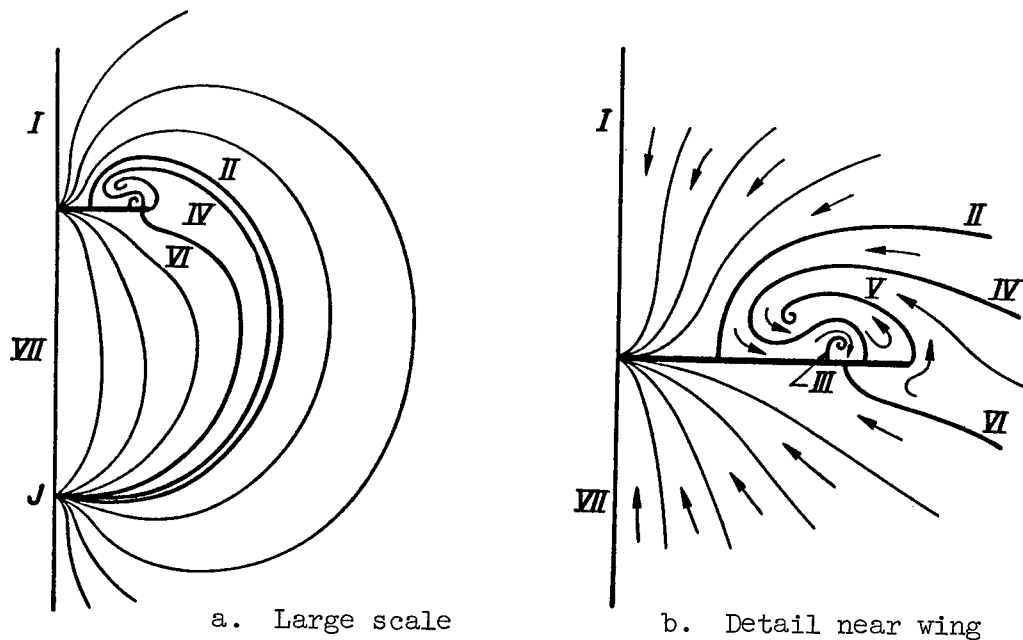

Figure 5. Traces of the conical stream surfaces of the flow around the delta wing.

Lines I and VII, traces of the plane of symmetry, are really not boundary lines, because they do not go through a saddle point. They correspond to isolated lines at nodes which, because of the symmetry, happen to have only local significance. Lines II, IV, VI are boundary lines going through saddle points. Lines III and V are traces of the horn-type vortex surfaces.

V. Blunt Ogives

The flow around blunt ogives of revolution already separates under zero angle of attack. A separation bubble is formed, without having a streamline coming from infinity entering it.

Werlé (ref. 2) has studied the flow around such ogives placed at a certain angle of attack. The bubble is swept by windward streamlines at the ogive. It is cut there and takes the form of a horseshoe whose two sides are directed downstream. On the other hand, the bubble moves slightly forward (leeward), while thickening.

The phenomena depend greatly on the shape of the ogive and are very complicated. The observation is made most difficult by the relatively small thickness of the separated domain, and interpretation is also difficult.

For the Rankine type of ogive (not too blunt, however), the author doubts that the vortex line actually crosses the plane of symmetry, as the interpretation of Werlé suggested. It seems more probable to the author that the vortex axis is almost immediately broken when the angle of attack increases,

either windward or leeward, and that the two separated extremities come to stick to the ogive at the foci. Two horn-type vortex sheets are formed, analogous to those observed on slender ogives, but enclosed inside the separation bubble. /9

The effects interpreted above are sketched in figure 6, without further comment.

When the ogive is still less slender, for example, the hemispherocylindrical ogive, a secondary vortex shows up. In this case, the observations of Werlé can be interpreted by means of a more complicated diagram (fig. 7) (which is rather hypothetical), which yields no additional information and will not be discussed here. The wall leeward lines are the only ones shown on one side only of the plane of symmetry. They follow the arrows indicated by Werlé. However, the discipline chosen to draw the lines completely and to the singular points obliges us to extrapolate the results by induction. Even if this process is imperfect, experiments guided by it can be undertaken. It is improbable that a more accurate description helps the mathematician to choose

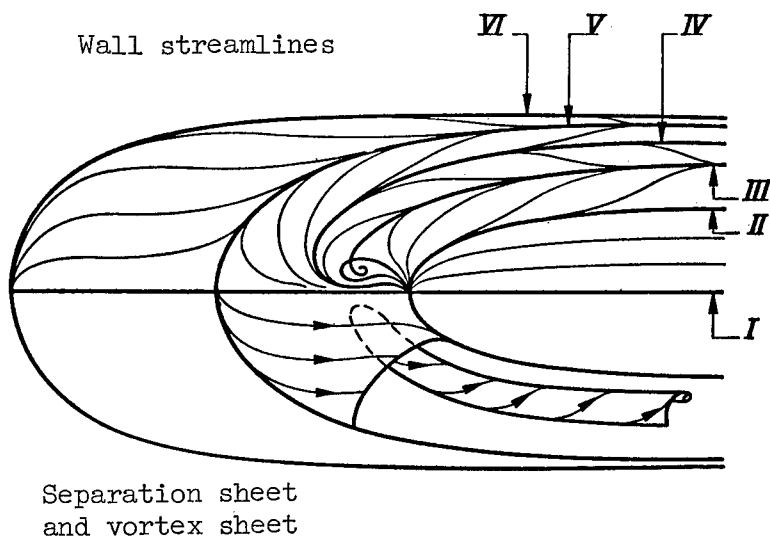

Figure 6. Flow around Rankine ogive.

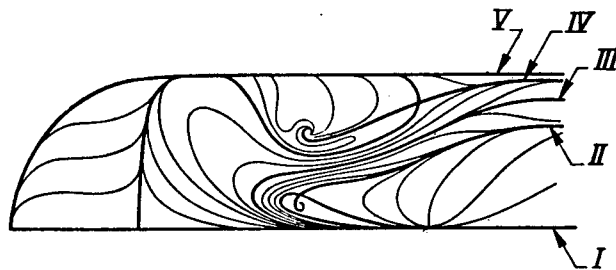

Figure 7. Wall flow on hemispherocylindrical ogive.

a set of starting assumptions that will enable him to attack the calculation of the very complicated flow, briefly described here. There have been cases, however, for example, the theoretical work of Eichelbrenner on the three-dimensional boundary layer, where the interpretation of the experiment, followed by complete drawing of the streamlines, has furnished bases for a complete calculation, fashioned on these results, and have permitted us to predict the results of experiments not yet undertaken.

VI. General Remarks

The comments of the preceding paragraphs have a fairly fragile mathematical basis. They are based only on considerations of continuity and regularity of the solutions of the viscous fluid mechanics equations, which were impractical for use.

The incidental use of the continuity equation was not even indispensable. It only narrowed down the relation between the roots of the equation in s and was only slightly helpful in the identification of the flow.

The author considers, however, that the few results obtained can be of use in efficient collaboration between experimentalists and theoreticians.

These results do not use complicated systems of equations. Nevertheless, they are far from being obvious, as proved by the inaccuracies and errors contained in a great number of published experimental and theoretical papers. These inaccuracies and errors would not have occurred, had there been a complete and coherent description of the flow.

In the complicated practical problems of interest to engineers it is useless to regret that it is impossible to solve, and even to discuss, all of the equations. Indeed, any useful information, even very fragmentary, is worth noting.

It is now necessary to see whether it is possible to proceed further with these equations.

As soon as the streamlines are established, product ρV on a surface going through the streamline determines product ρV on any other surface going through the same streamlines. Nothing more should, therefore, be expected from the continuity equation for the description of the streamlines than these consequences of the convergence of all streamlines to a point. This entails an infinity of ρV , and consequently, by definition, the existence of a source of streamlines.

The flow is practically defined when the streamlines are established and ρV is determined to within an arbitrary function of two variables, which depends on the values it takes on a surface cutting the streamlines. If it is an observed flow, the equations of fluid mechanics are automatically satisfied. This proves, however, that the data on the streamlines and on ρV on the cross-sectioning stream surface, cannot take any arbitrary value. Certain

conditions must be imposed, for example, on the streamlines, which were not considered in the preceding analysis. It is useless to regret this neglect. On the contrary, since we do not understand the whole process we should be pleased that we are able to eliminate unacceptable conditions.

Since some authors cannot discuss the solutions to the equations and simultaneously consider the boundary conditions, they perform a deeper local analysis than the one we sketched, taking into account all equations. This procedure is not very useful and is even dubious, unless principles analogous to those proposed are taken into account in order to replace an acceptable existence and uniqueness theorem.

Let us examine in particular what can be added to the study in the vicinity of a singular point for an incompressible fluid flow. The two equations that must be satisfied are

$$\operatorname{div} V = 0 \quad \operatorname{curl} [V \wedge \operatorname{curl} V - \nu \Delta V] = 0.$$

In the second equation, which is a vectorial one, ΔV is finite at the singular point and is written as a function of the coefficients of the second order terms in the expansion of ρV , taken here as V . This second equation does not add any new information on the coefficients of the first order terms of the ρV expansion, except that, considered as functions of the dynamic viscosity ν , they must be such that $\operatorname{curl} [V \wedge \operatorname{curl} V]$ tends to zero with ν .

At the limit, when $\nu = 0$, the two equations express the fact that either $\operatorname{curl} V = 0$ at the singular point or there exists a line going from the singular point in the direction of $\operatorname{curl} V$, on which the velocity is of the second order.

VII. Conclusions

The study of the vicinity to singular points where the velocity is zero inside the fluid or on obstacles can be carried out starting from preliminary principles in lieu of a precise existence and uniqueness theorem, not actually available.

It leads to useful results, which are far from obvious and which permit us to distinguish, to within degeneracies, two types of singular points: those in the vicinity of which there exist three sets of approximately planar streamlines, which form one node and two saddle points, and those in the vicinity of which there exists only one set of approximately planar streamlines, which form a focus.

These results enable us to interpret the widely varied observations performed on complicated flows.

REFERENCES

1. Legendre, R. Regular Laminar Separation (Décollement laminaire régulier). C. r. Acad. Sc., Vol. 241, p. 732, 1955.
2. Werlé, H. Separation on Bodies of Revolution at Low Velocities (Le décollement sur les corps de révolution à basse vitesse). Rech. Aéron., No. 90, September, 1962.
3. Legendre, R. From Ship-Accompanying Waves to Shock Waves of Supersonic Airplanes. J. Royal Aeronaut. Soc., Vol. 66, March, 1962.
4. --- Horn-Type Sheets at the Leading Edges of Delta Wings (Nappes en cornets aux bords d'attaque des ailes delta). Rech. Aéron., No. 70, May, 1959.
5. Werlé, H. An Attempt to Verify the Conicalness of the Flow Around a Delta Wing (Essai de vérification de la conicité de l'écoulement autour d'une aile delta). Rech. Aéron., No. 63, March, 1958.

Translated for the National Aeronautics and Space Administration
by John F. Holman and Co. Inc.