

Integration of Control Systems with Condition-Based Maintenance (CBM) Systems

**SBIR No. 1-037:
Technology for Shipboard Affordability**

Submitted to:

Mr. John Carney, Code 361
Office of Naval Research
Ballston Tower One
800 North Quincy Street
Arlington, VA 22217-5660

Submitted by:

Lewis Watt
RLW, Inc.
1346 South Atherton Street
State College, PA 16801
(814) 867-5122
lwatt@rlwinc.com

20 October 2001

20011102 013

TABLE OF CONTENTS

1.0 EXECUTIVE SUMMARY	1
2.0 PRELIMINARY DESIGN	2
2.1 Measurement Requirements	2
2.2 Optional Measurements.....	3
2.3 Control System Integration.....	3
2.4 System Configuration.....	5
2.5 Monitoring and Recording Compressor Disc Health.....	6
2.6 Recording Counts.....	7
2.7 Wireless Hand Held Device.....	7
2.8 Small, Smart, Wireless Sensor Development	9
2.8.1 <i>Hardening</i>	9
2.8.2 <i>Miniaturizing</i>	10
2.8.3 <i>Power Supply</i>	10
2.9 Health Processor.....	10
2.10 Software.....	11
2.11 Diagnosis and Prognosis.....	11
3.0 ADDITIONAL BACKGROUND AND RESEARCH.....	12
3.1 Resources.....	13
4.0 WORK PLAN.....	13
APPENDIX A. S-N CURVES AND MINER'S RULE	15
APPENDIX B. CONTROL SYSTEM BLOCK DIAGRAMS	17
APPENDIX C. COUNTS.....	19
APPENDIX D. ACRONYM LIST	20
ATTACHMENT 1. ALLAN LEES' ARTICLE	21
ATTACHMENT 2. NEWPORT NEWS SHIPBUILDING LETTER	42
ATTACHMENT 3. GOVERNOR'S ACTION TEAM LETTER	43

TABLE OF FIGURES

Figure 1. Approximate Sensor Locations.....	3
Figure 2. PC-104 Health Processor.....	5
Figure 3. Sensor Readings.....	8
Figure 4. Correlation Plot.....	8
Figure 5. The ICHM [®] 20/20.....	9
Figure 6: Gantt-Chart Showing Phase I and Phase I Option Tasks and Schedule	13
Figure 7. Production Intent Basic Engine Block Diagram.....	17
Figure 8. Production Intent Application Block Diagram.....	18

1.0 Executive Summary

The project has progressed as planned in the proposal and has arrived at a design for a diesel turbo compressor condition-based maintenance (CBM) system which combines inputs from existing control systems; adds a limited number of small, smart, wireless sensors; and uses control system hardware and software to provide the useable health information to operators and maintainers. The system is designed to be affordable and to provide maintenance savings to both commercial and Navy users.

The initial task of the project included meetings and interviews with personnel from Caterpillar, Newport News Shipbuilding, Electric Boat, and Fleet Technical Support Center, Atlantic (FTSCLANT), to discuss diesel generator set failure modes, frequency, and seriousness. These meetings and the SBIR kick-off meeting directed the focus to the turbo compressor components. Although consensus regarding priorities was not reached with all participants, much valuable information was gathered to support future CBM designs for other diesel generator set components.

The CBM system designed in this effort will monitor the health of the turbo compressor (TC) by sensing at several locations on the TC, reducing the data collected at the sensors, and executing comparisons and trending at the node known as the System Health Monitor (SHM[®]). The hardware that constitutes the SHM[®] will vary among engine models and configurations to take best advantage of the marriage with the control system. The CBM system will measure performance of the TC using pressure and temperature data collected across both the turbine and the compressor. Various oil parameters will be monitored and trended. Vibration will be measured at locations that offer access to the bearings and at the mounts between the TC and the engine.

The highest pay-off and most challenging development addresses the combination of steps needed to determine and record the remaining useful life (RUL) of the compressor disc. The life of the disc is limited primarily by exceedences in RPM that drive low-cycle fatigue of the disc. Two approaches were chosen: RPM will be measured and used in a system of "counts," wherein time spent above design RPM will be weighted using traditional S-N curves and Miner's Rule (see Appendix A) to predict the effect on disc life; concurrently, the vibration measurements will be analyzed for features that will provide indications of the health of the disc, thereby applying conventional CBM methodology. Each of these approaches will provide measures of the other, increasing the validity of both as experience is gained.

Recording counts falls into the broad category of tracking life-limited items through repair. Anyone who has been involved in overhauling costly machinery will appreciate both the value and difficulty of monitoring life-limited components. In the follow-on effort, RLW will identify the best method of tagging and updating compressor discs with their RULs. RLW recognizes the advantage of supporting disassembly, repair, and reassembly of TCs that involves mixing and matching components. The ideal for the TC is a device that is regularly and automatically updated with the counts score, which is exhibited such that it can easily be read on both the workbench and the installed disc. The 30,000-RPM, heat-sink environment of the disc does not suggest simple solutions.

RLW is working to align testing resources for Phase II. Newport News Shipbuilding has identified a small diesel engine that will be used for testing sensors and ICHMs[®]. In addition, Allan Lees of DSA International is arranging for the availability of several large Caterpillar engines for full-scale testing and demonstration. Both NNS and DSA have found strong support for the project, including indications that commercialization will be well received. Caterpillar will continue to support the project with man-hours and with matching funds. The State of Pennsylvania will also provide matching funds for Phase II.

2.0 PRELIMINARY DESIGN

2.1 Measurement Requirements

The preliminary design called for the measurement of the following variables:

- ***Vibration at the bearings:*** Turbo compressor manufacturers use various types of bearings to support the turbine and compressor discs. Regardless of bearing type, vibration at the bearing is an essential and basic measure of system health.
- ***Temperature at the bearings:*** Applying the philosophy that decisions will not be made on the basis of one indication, bearing temperature is the best variable for confirming a trend indicated by bearing vibration.
- ***Oil temperature and pressure inside and outside of the bearings:*** Data collected early in phase I indicated that many turbo compressor failures were preceded by some lubrication event. In fact, one Navy diesel inspector stated that all failures he had seen were caused by lube failures. Although these measurements may fall on the line between CBM and warning systems, they cannot be ignored in this design.
- ***Performance measures:*** This set includes temperature and pressure into and out of both the turbine and compressor. Basic to establishing health vectors of the system, these measures will support trend analysis to be used as a primary indicator of health or as backup for other indicators.
- ***Vibrations at the mounts:*** This measure will define the vibration environment the turbo compressor is subjected to as a result of the mounting location, mounting hardware, and engine vibration. The information collected will be useful in separating the cause and effect of health trends. Data collected earlier in Phase I strongly supported the need for this information.
- ***Compressor disc/blade condition:*** Two approaches will be used for compressor disc health monitoring. The first will "count" weighted RPM exceedences, requiring a tachometer on the TC; the second will rely on the vibration measurements taken at or near the front bearing. A thorough discussion follows in Section 2.5, Monitoring and Recording Compressor Disc Health.

Figure 1 shows the approximate locations of the sensor on the turbo compressor.

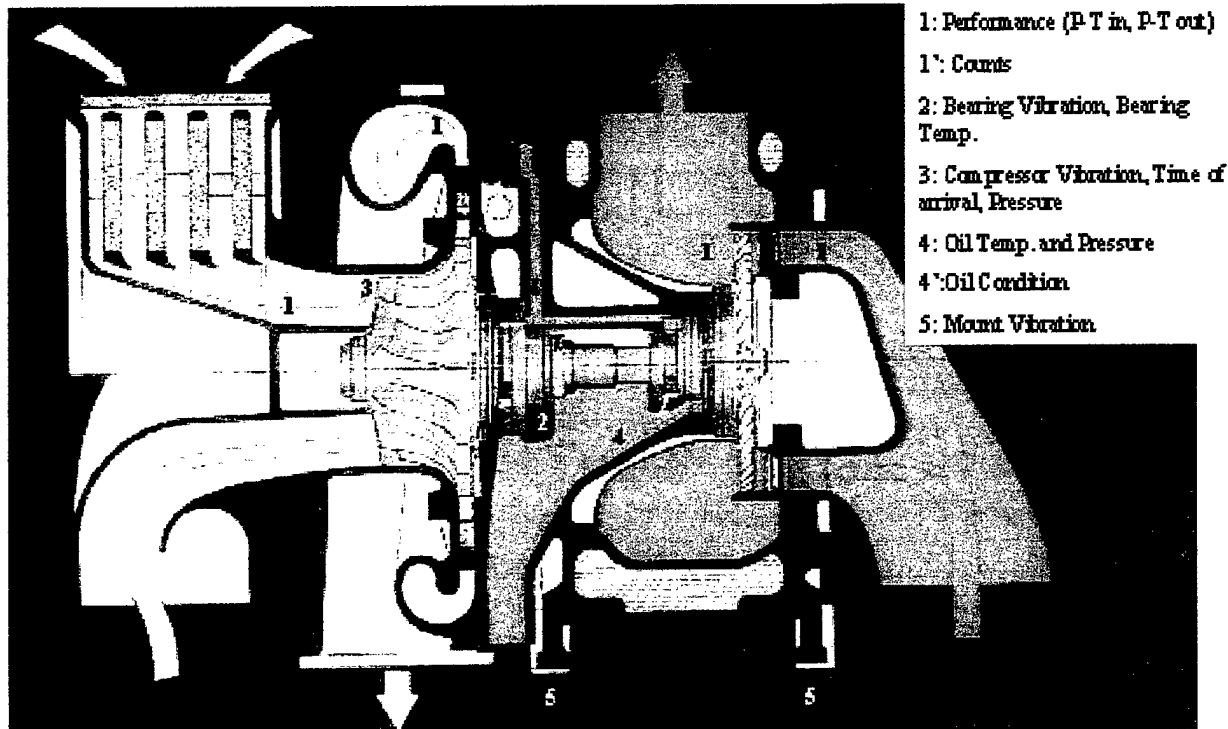

Figure 1. Approximate Sensor Locations

2.2 Optional Measurements

Oil condition and oil analysis: Navy-funded systems, which are in the prototype stage of development, will provide online, near-real-time indications of lube condition and analysis. Lube condition indicates the health of the lube (e.g., content of water and other impurities, and levels of anti-oxidant and other additives), and oil analysis provides excellent indications of component health based on the content of metals and other impurities in the lube, which result from system wear. If affordable, these systems may move to the required list.

2.3 Control System Integration

The intent of the project is to achieve designs that can be readily and affordably modified to enhance any large diesel generator set, or diesel used in any of a wide variety of stationary applications. For demonstrative purposes, the effort focuses on Caterpillar 3600 and 3500 series diesels for shipboard applications. The 3600 series is currently sold with a manual control system, while the 3500 series has been available with digital electronic control (DEC) systems for several years. Selection of these two diesels provides the project with access to a DEC with which to integrate, while offering both Caterpillar and the project growth opportunities related to the development of a DEC for the 3600 series. In other words, the project has a starting point with which to determine how best to integrate, and the opportunity to affect the near-term designs of Caterpillar's control system team.

The 3500 series typically is equipped with the Model 130-7481 Engine Controller. This DEC manages the electronic fuel injectors and senses approximately 24 parameters on and related to the engine's environment, performance, and subsystem behavior. Block diagrams are shown in Appendix B. The DEC includes several warning capabilities and some (optional) fundamental diagnostic systems, such as oil and fuel differential pressures. The DEC offers both service tool and service probe access to data and information, and communicates with the Vehicle Information Management System (VIMS), an optional Caterpillar feature.

The project will integrate at three levels:

1. Simply by using the signals from sensors that are already are part of the 130-7481 DEC
2. By using the processing capacity of the DEC in lieu of, or supplemental to, adding additional processors
3. By communication with existing or future, on- and off-engine systems for human interface (e.g., VIMS for commercial vehicle applications and ships' local area networks and systems, such as the Integrated Condition Assessment System [ICAS], which the Navy primarily applies to standby and service generator sets)

Each of these three levels of integration offers opportunities to replace wires or introduce wireless communication, substantially reducing the likelihood of increasing wiring maintenance, while attempting to reduce overall maintenance through CBM practices.

The first of these levels will use the data streams from four sensors installed in 130-7481 systems: Right and left turbo inlet pressure, turbo outlet pressure, and atmospheric pressure. These signals are fundamental to the measurement and tracking of turbo compressor performance. When combined with similar data that will be collected using wireless sensors on the compressor, performance can be normalized to atmospheric pressure and temperature, and trended to detect degradation in TC performance. Other sensors in the array will be useful when the CBM system expands beyond the TC; the speed and timing sensors and the crankcase pressure offer the potential for future integration.

The second level of integration will result in substantial savings and will offer CATERPILLAR the opportunity to provide CBM options best suited for various uses of their diesels. The 130-7481 has some spare processing capacity, enabling CBM functions to be added without requiring an additional processor. Unlike control, CBM seldom requires real-time processing and response (i.e., a few seconds are not critical), so CBM data can be saved briefly before being processed, to accommodate peaks and valleys in the control function usage. An approach that will be explored more thoroughly in the Phase I option involves processing TC performance data in the 130-7481, while processing other CBM data on the various small, wireless sensors that will be added to complete the system. The project will test this and similar approaches during Phase II by including in the prototype CBM system a PC-104 module that runs the same operating systems and language as the 130-7481, to ensure that control will not be compromised by adding the additional workload to the 130-7481 processor. The project will take advantage of data access afforded by the service probe and/or service tool in the DEC system to route data to the PC-104.

A typical PC-104 processor is shown below in Figure 2. This unit of hardware and software will be known as the *health processor* throughout this report.

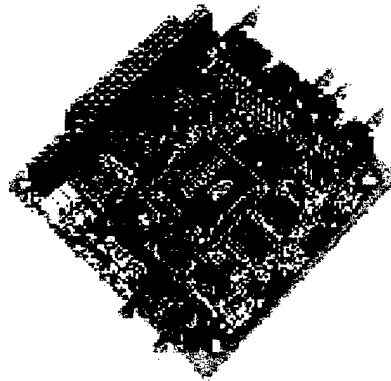

Figure 2. PC-104 Health Processor

The third level of integration will ensure that the output of CBM information from the integrated system conforms to the requirements of the emerging Open Systems Architecture for Condition-Based Maintenance (OSA-CBM) program, which details the formats and structures required for CBM systems. The Navy plans to accommodate the requirements of OSA-CBM in its ICAS and other systems. RLW has played a significant role in OSA-CBM development and will ensure system compliance in this project.

2.4 System Configuration

The basic system will include three small, smart, wireless sensors, such as the Intelligent Component Health Monitor (ICHM[®]), which is in development by Oceana Sensor Technologies, Inc. (OST), and a health processor (the System Health Monitor [SHM[®]] by OST) to collect, compare, trend, and otherwise process data to ensure that useful information, not data, is presented to the user. Options may increase the number of smart sensors as additional variables, such as oil analysis, are added to the system. Most smart sensors are delivered with a basic package of embedded software, including application software. Wherever practical, this software will be employed. As discussed above, the health processor could ultimately reside in the signal processing hardware of the engine control system, but the prototype will use a PC-104-based processor that is currently in design.

The smart, wireless, sensors will be employed as follows:

- Smart Sensor #1
 - Bearing/compressor vibrations – two axes
 - Oil temperature in and out of bearing lube area
 - Oil pressure in and out of bearing lube area

- Smart Sensor #2
 - Vibration at the mounts

- Compressor pressure in and out
- Compressor temperature in and out

- Smart Sensor #3
 - Bearing/turbine disc vibration – two axes
 - Turbine temperature in and out
 - Turbine RPM, if not installed in control system

(Note: Turbine pressures will be monitored by control system sensors.)

The health processor will perform the following functions:

- **Performance Tracking:** The health processor will contain the application software to normalize and trend performance data to show performance as an indicator of system health. Included will be performance of the turbine, the compressor, and the system.

- **Vibration Comparisons:** While the small, smart sensors will process vibration data into useful information about the individual mount, bearing, or disc, effective health monitoring dictates that comparisons be made between the various elements of the system.

- **Compressor Counts:** The health monitor will manage this program, which will develop on the fly as data is gathered. The concept is essentially to weight minutes spent at higher RPMs more heavily than at some norm when determining the remaining life of a component. Appendix C is offered as an example of a Counts program applied to the F-402 engine.

- **Various Comparisons:** The health monitor will compare performance trends with counts, counts with disc vibration trends, and bearing vibration trends with oil analysis trends. Many other combinations may become tools for determining RUL of system components. These pairs of trends will be further developed during the remainder of Phase I, throughout Phase II, and well into the commercialization of the health monitoring system.

2.5 Monitoring and Recording Compressor Disc Health

Compressor disc life is limited primarily by low-cycle fatigue, which is driven by the centrifugal forces encountered during normal usage and, to a greater extent, by periods of use when RPM exceeds the limit for which the disc was designed. Early in this project, RLW assumed that temperature deviations were the issue; however, despite the fact that we changed our approach based on our findings, we did not have to change the monitoring concepts appreciably. RPM will be tracked using sensors that exist in the control system suite, where available, or will be collected on the #3 smart sensor.

The technical challenge involves developing a method capable of predicting the RUL of the disc, using both traditional engineering methods and sensed changes in the behavior of the impeller. RLW, Inc. intends to monitor RPM and, using S-N curve and Miner's rule approaches, establish

a "count" system similar to those used to address temperature considerations on jet engines installed in vertical take off and landing (VT/OL) aircraft. Simplistically, a minute at 110 percent of design RPM uses compressor life at a rate greater than a minute at design RPM. RLW will, as a part of Phase II, execute the engineering necessary to define these relationships. While far better than no monitoring or prediction, this approach is not CBM, in that it deals with assumptions about a population of compressor discs, rather than the single disc being monitored. Therefore, RLW will collect vibration data and will develop the relationships between the counts, the features extracted from vibration data, and RUL of the disc. This approach should generalize to other components in a wide variety of applications.

2.6 Recording Counts

An additional, very challenging need relates to the counts approach. Considerable benefit could be gained from having repair facilities that are capable of recording and automatically updating (on the compressor disc) the RUL, as determined by the counts method discussed in the previous section. Ideally, a device would be added to each disc that could be updated wirelessly by a smart sensor or the health processor as counts are accumulated. The device need not be capable of signal processing; it need only accept and record updates from the smart sensor such that RUL can be determined should a removal occur. The device must be able to withstand the RPM and heat-soak that are inherent in the environment. The counts should be readable in some rapid, affordable manner, both on an installed disc and on the workbench. Such a system will accommodate the frequent swap of parts among turbo compressors without losing the benefits of the CBM system. A decision will be made as to whether to include this need in Phase II scope as priorities are matched with budget.

2.7 Wireless Hand Held Device

RLW has determined, on several projects, and confirmed during the first task of this project, that operators and maintainers want to have access to information about the health of their machinery while standing in the machinery space. This access will be accomplished via the use of wireless hand held devices (HHD), such as the Palm V show in Figure 3.

Using HHDs does not affect the functioning or the importance of the system's linkage to the ship or facility local area network and/or the Internet. Adding wireless HHDs allows the human in the loop to employ all of his senses and intelligence on site, while simultaneously accessing the individual wireless sensors and the health processor.

This project will borrow from the HHD and HHD display formats and human interface techniques that have been developed by RLW using SBIR project funds, as well as work performed for Electric Boat on an IR&D-funded commercial application. The software allows the operator to use the HHD to query and monitor selected sensor channels and then display the data in various modes, such as a listing of temperatures, a plot of temperatures from a single sensor, or a correlation of data from multiple sensors.

RLW will, during Phase II, determine the HHD information and formats that will be most useful to diesel operators and maintainers and tailor existing programs accordingly. RLW is in discussions with various HHD manufacturers, has access to a variety of commercial HHD

designs, and is confident that the needs of the project can be met by one of the COTS HHD devices that are available. For example, Symbol Technologies, which manufactures rugged portable data terminals for warehouse and loading dock use and Bluetooth radio components, is capable of providing a variety of fully satisfactory HHDs.

Examples of HHD displays are shown in Figure 3 and Figure 4. The two PDA screens illustrate how wireless device display formats can be used to provide information to maintainers during an engine operation.

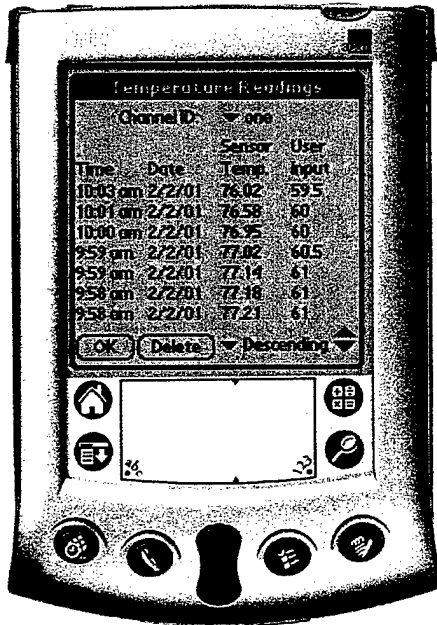

Figure 3. Sensor Readings

This screen is accessed via the pull-down menu from any of the major screens, and displays a table listing all of the sensor records currently stored on the Palm V. Any channel can be selected from the “Channel ID” pull-down. The screen will then populate with the data from that channel. The channels can be sorted by either “ascending” time or “descending” time.

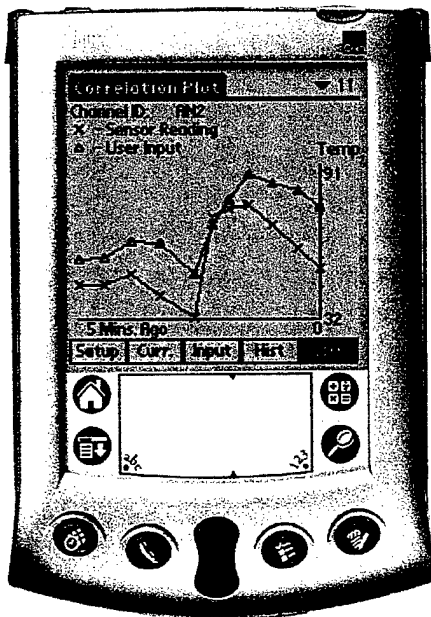

Figure 4. Correlation Plot

Selecting the “Corr” button at the bottom right of the display accesses this screen. The graph displays the last 11 reading for the selected channel from the previous screen and the corresponding predicted sensor readings.

2.8 Small, Smart, Wireless Sensor Development

Fundamental to the design of the system is the development of small, smart, wireless sensors, which is progressing very rapidly. The ICHM[®] 20/20, which is shown in Figure 5 and is commercially available, is an example of one such sensor. The dimensions of this device are approximately 3x3x4 inches. The ICHM[®] offers two channels for high-speed data collection (e.g., vibration) and four channels for low speed data collection (e.g., temperature, pressure, and most other variables). The ICHM[®] contains a powerful processing capability. Data received from the array of attached sensors is processed in the ICHM[®], so that information, not data, is transmitted to the health processor for further processing.

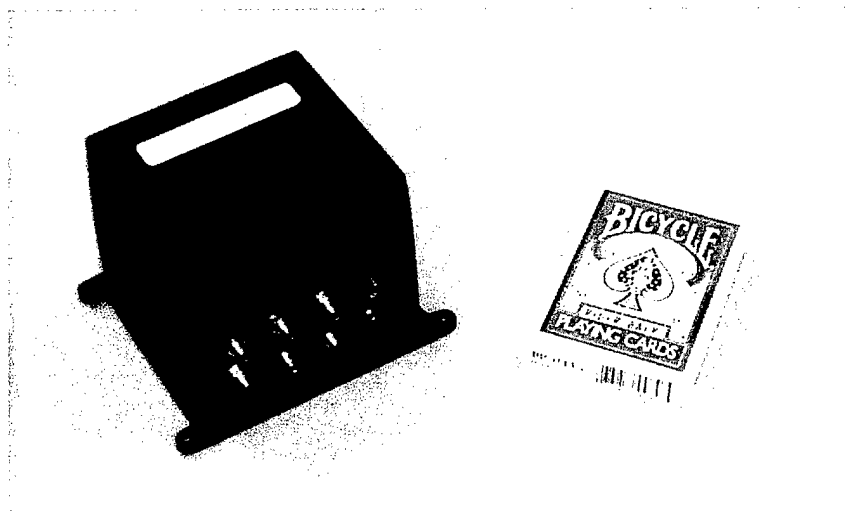

Figure 5. The ICHM[®] 20/20

The ICHM[®] incorporates a Bluetooth[™] wireless technology transmitter/receiver for wireless transmission of the information and reception of reprogramming instructions as required. Several other radios, such as 802.11(a or b) or Home RF, can be employed in this role. Each ICHM[®] is capable of transmitting within a range of approximately ten meters with Bluetooth or a range of 100 meters with 802.11b. The information transmitted will be collected by the health processor, and will be available for collection by other devices that have matching radios and are correctly programmed for the communication. For example, several ongoing prototype applications include the use of personal data assistants (PDAs) as walk-around monitoring aides.

Smart sensor development is progressing in several areas, including hardening, miniaturizing, and power supply issues.

2.8.1 Hardening

RLW and OST are working to harden the ICHM[®] for this and several other projects. One system is now installed aboard a DDG, funded by an ACI program. The system requirements include the ability to withstand salt-water wash-down and other shipboard machinery space environmental issues. Two aviation programs are ongoing: the DARPA-funded ICHM Dual Use Application

Program (DUAP) and a NASA-funded flight-test program during which ICHM[®] will be exposed to the temperature, altitude, and vibration environments of the C-17 engine fan casing. OST and RLW efforts in the realm of hardening include board design, fasteners, and packaging. RLW believes that the diesel environment, both aboard ship and in commercial installations, is less than or equally demanding as the C-17 installation environment.

2.8.2 Miniaturizing

The rapid growth in commercial electronics is driving down the size of the components used in ICHM[®] and other system electronics at a pace which makes freezing of designs a serious management and engineering challenge. The ICHM[®] pictured in Figure 5 is just arriving in the marketplace; it is comprised of three linked circuit cards that each perform a distinct set of functions: communications, signal processing and conditioning, and power management. Each card in the current stack is approximately 2x4 inches. Communication cards are now available that are less than half that size, and significantly smaller signal processing hardware is emerging for commercial applications. In the proposal which led to this SBIR project, RLW suggested that an ICHM[®] housed in a one inch cube would become available in future years. We can now safely predict that a 2x2-inch ICHM[®] will be available for testing early in Phase II, and the one-inch cube will be a reality before the end of that phase.

2.8.3 Power Supply

Power supply can be treated as a hardening issue because, while replacing data wire with RF transmitters is fundamental to a rugged, modern CBM system, eliminating wires that provide power will also enhance system durability and reduce lifecycle cost. Power scavenging technologies are moving out of the laboratories and into commercial availability. RLW and OST have recently contracted to demonstrate, aboard Navy YPs, sensors powered by batteries recharged in situ by thermo-electric devices. RLW predicts that this technology will mature sufficiently to be demonstrated during Phase II of this program. RLW and OST are committed to bringing this and other power scavenging technologies to the CBM marketplace as quickly as their maturity permits.

2.9 Health Processor

RLW will use PC-104 technology for the health processor, first as an interim solution on the prototype system (pending transfer of the health processor functions to the DEC), and indefinitely on engines without DECs. PC-104 is an excellent choice for this application because of the size, weight, and power attributes of the PC-104 components, and the multiple sources of PC-104 cards. PC-104 technology was developed for commercial use in embedded or industrial applications. PC-104 cards with an extended operating temperature range of -45° to 85° C are commonly available and will be used for this project. The PC-104 technology eliminates the fixed backplane necessary in a PC, VME, or compact PCI format. Additionally, RLW engineers have in-depth of experience with PC-104 systems design and are confident of this choice.

2.10 Software

The heart of this, and any smart, wireless CBM system is its software. Accordingly, the bulk of the work performed has been in the development of software systems, and in writing the documented, quality, efficient, code necessary to enable a CBM system to run. Wherever possible, RLW had leveraged our experience from other projects in performing the work necessary to position this project for a successful Phase II. The goal is to develop CBM software that will run unattended for long periods of time, preventing any unnecessary maintenance burden. Software in several categories has been completed; other software is in advanced development. All software, however, requires maintenance and upgrades.

RLW has developed the firmware or operating system for OST's ICHM[®] and has developed the toolkit with which to write and load the application software necessary for the wide variety of monitoring applications. Using this toolkit, RLW has adapted several algorithms that existed in the public domain, reducing these hardware/firmware/software/algorithm combinations to practice.

RLW has found an array of opportunities in which to test and demonstrate these efforts. A combination of temperature and vibration sensing has been in operation for two months on an industrial shaker at United Technologies Research Center (UTRC). This UTRC project simulates various helicopter applications, primarily bearing and gearbox monitoring. A similar system is running at a paper mill in Virginia.

More challenging demonstrations are in progress. On 25 September, RLW demonstrated a wireless sensor system, running only RLW software, for monitoring a large pump/valve system, sending information wirelessly to the company's LAN and rendering it available for Internet transmission. The system reports trends in temperature, pressure, and vibration. Close behind is the system designed for Pratt & Whitney and NASA, which uses a wireless sensor to report engine information about the same three parameters. Both of these applications use algorithms that are in the public domain.

Preschutti Associates, a State College engineering company, is using RLW's toolkit and firmware to write application software for the proprietary algorithm developed by Dr. Joseph Cusumano, co-PI of this project. This combination holds promise for the compressor disc application discussed elsewhere in this report.

In summary, the software development during Phase I has been substantial.

2.11 Diagnosis and Prognosis

A review of the current state of practice, performed by Dr. Joseph Cusumano, a member of the project team, showed that little research had been performed prior to this effort that addressed turbo compressors as systems or components. While this fact confirms that the current project does not duplicate earlier efforts, it also indicates that substantial ground must be covered to develop a sound CBM system for the first time.

Dr. Cusumano led a review of the current state of the art in turbo compressor diagnostics and prognostics, focusing on a review of available academic literature in the form of journal and proceedings articles. The aim was not to summarize general diagnostic/prognostic and condition monitoring approaches, but to look for methods *specifically targeted* at turbo compressors. Despite the team's efforts in this area, we have not yet found papers that address this specific subject, although in the process of performing this work we have added some 15 papers to a general bibliography dealing with condition monitoring algorithms. Note, however, that there is a reasonable amount of published work dealing with diagnostics/prognostics for bearings, gears, and rotating machinery, all of which have some relevance to turbo compressors. We are continuing to search the literature, and recommend that we broaden our search to include manufacturers of turbo compressors, to better identify any current or planned diagnostic/prognostic programs and approaches originating in industrial research labs.

Despite the apparent lack of research on turbo compressor prognostics, the preliminary evaluation of performance and maintenance issues clearly indicated that condition monitoring, including online health monitoring and failure prognostics, should be possible for turbo compressors, based on existing work applied to other machinery. As a result, RLW defined the following key performance/health variables for turbo compressors.

There are two distinct (but interrelated) categories of health state variables: thermodynamic variables, which mostly are related to the performance and efficiency of the turbo compressor, and mechanical dynamic variables, mostly related to the physical condition and reliability of the turbo compressor. The thermodynamic variables include the inlet and outlet pressure and temperature, and mass flow rates through the impellers. The main mechanical variables include vibrations, as measured at the casing, over the bearings, or directly from the rotating shafts, and shaft rotation speed. Variables that fall somewhat in the middle of these two categories include measurements of lubrication oil temperature and flow rate, and bearing temperatures. These variables are all interrelated and ideally would all be measured in an initial test program.

At this stage, we can reasonably assume that mechanical vibration signals will be the variable that most directly relates to the development of outright failures. Thus, a minimum set of observables should include vibration data, together with temperature, pressure, and shaft speed (the latter three items are required for load-determination and context-based modeling). Ideally, vibration data would consist of acceleration or strain measurements near the bearings for bearing failures, and x - y displacement of shafts for impeller/shaft failures. In reality, though, these items are strongly coupled, and can be monitored with case-mounted accelerometers (as has been demonstrated previously). Because the lubrication system is so critical to turbo compressor performance, at least some oil supply information will likely be a critical part of condition monitoring—if not for model-based diagnostics and prognostics, then at least for fail-safe alarms and context modeling.

3.0 Additional Background and Research

Allan J. Lees of Dynamic Signal Analysis International Corp. has consulted with RLW, Inc. on several occasions regarding diesel CBM and related topics. Mr. Lees provided the document entitled "Condition Monitoring and Vibration Analysis of Diesel Generators with an Emphasis

on Turbochargers” which is shown in Attachment 1. The document will assist the reader in visualizing and understanding CBM of diesel turbo compressors.

3.1 Resources

Electric Boat and Newport News Shipbuilding continue to show an active interest in this project. NNS has agreed to ensure the availability of a turbo compressor-equipped diesel for Phase II trials. Andy Pool of NNS has located a small engine that will be ideally suited for the work envisioned and he is procuring the diesel for installations at Virginia Advanced Shipbuilding and Carrier Integration Center (VASCIC). VASCIC has assured RLW of continuing cooperation throughout the project, as described in the attached NNS letter. (See Attachment 2.) Additional support will be provided by the Governor’s Action Team of the Commonwealth of Pennsylvania. The team has received several briefings on the project and is committed to providing the support necessary to ensure a Fast Track status if the project is selected for Phase II. (See Attachment 3.)

4.0 Work Plan

To complete the basic Phase I effort, RLW will design the health processor for the demonstration system and will review every other aspect of the work to date. Considerable detail will be accomplished at the analog sensor level of the smart sensors.

The Phase I Option has been exercised. Per the Gantt chart (shown in Figure 6), RLW will complete the design of the demonstration system, and within the limits of the budget, begin procurement of parts and fabrication of subsystems. The intention is to be fully prepared to launch a Phase II effort at the conclusion of the Phase I Option. As a result, RLW will be prepared to install and test elements and systems rapidly, to commence software development immediately, and to move to installation of a full demonstration system within four months.

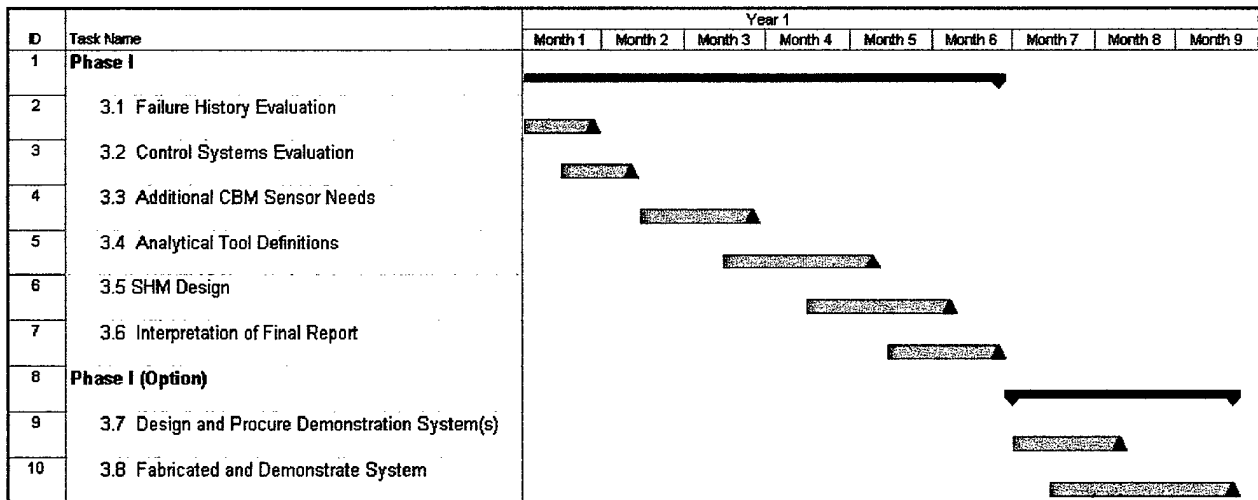
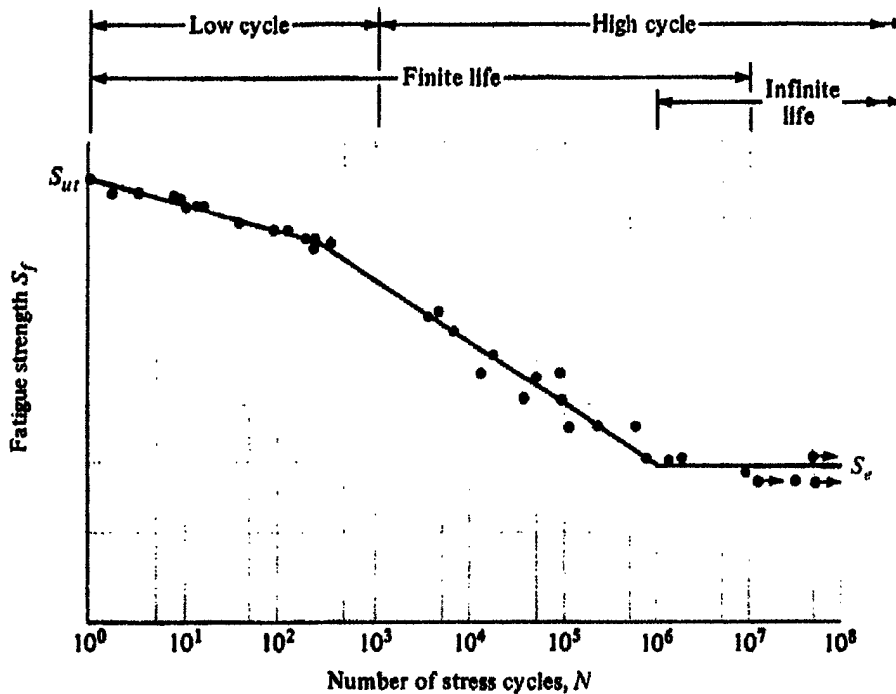

Figure 6: Gantt-Chart Showing Phase I and Phase I Option Tasks and Schedule

Briefing Cancellation: As a result of the attacks on the Pentagon and the World Trade Center, the NSRP briefing described in the last progress report was rescheduled for December 2001.

Appendix A. S-N Curves and Miner's Rule

S-N Diagram:



- One cycle consists of a loading in one direction, removal, then loading in the opposite direction
- Each dot represents the breaking point of the material
- S_{ut} , ultimate tensile strength – material will break after one cycle at this stress, hence 10^0
- S_e , endurance limit/fatigue limit – at this level of stress, the material can be cycled indefinitely (in theory) and the S_e only exists for not-ferrous materials. (For ferrous materials, the Infinite lifeline will not be horizontal, as shown above.)
- S_f are the various stress levels at which the material is cycled. During the test, the stress level does not change.

Miner's Rule:

- Allows the estimation of useful life based on varying stress loads
- Used in conjunction with S-N curve

$$\frac{n_1}{N_1} + \frac{n_2}{N_2} + \dots + \frac{n_i}{N_i} = C$$

where

n=number of cycles at a given stress load

N=number of cycles until failure at given stress load (from S-N curve)

C usually lies at: $0.7 \leq C \leq 2.2$; however, many use $C = 1$

- A new endurance limit can be found for overstressed material based on Miner's rule.

Appendix B. Control System Block Diagrams

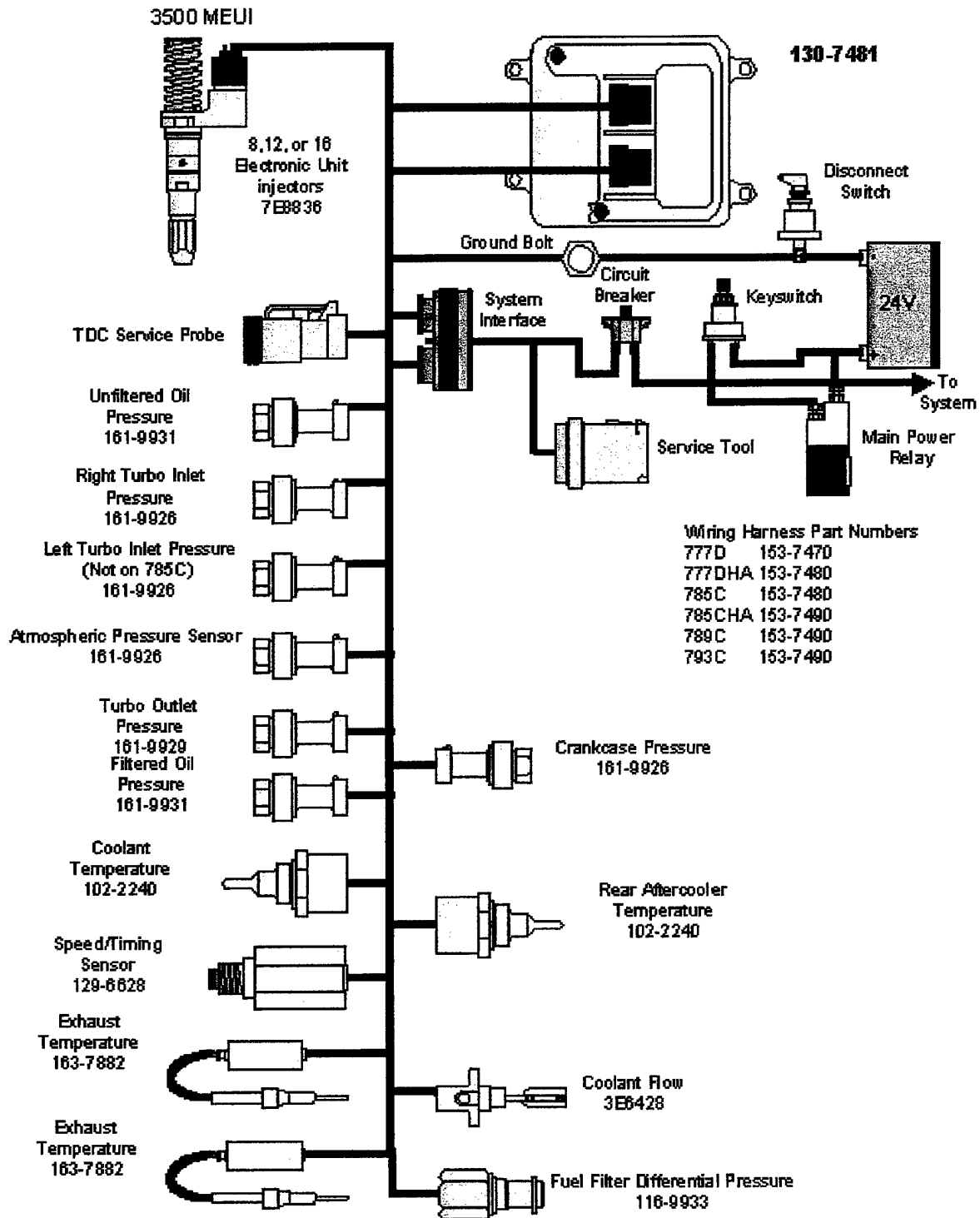

Figure 7. Production Intent Basic Engine Block Diagram

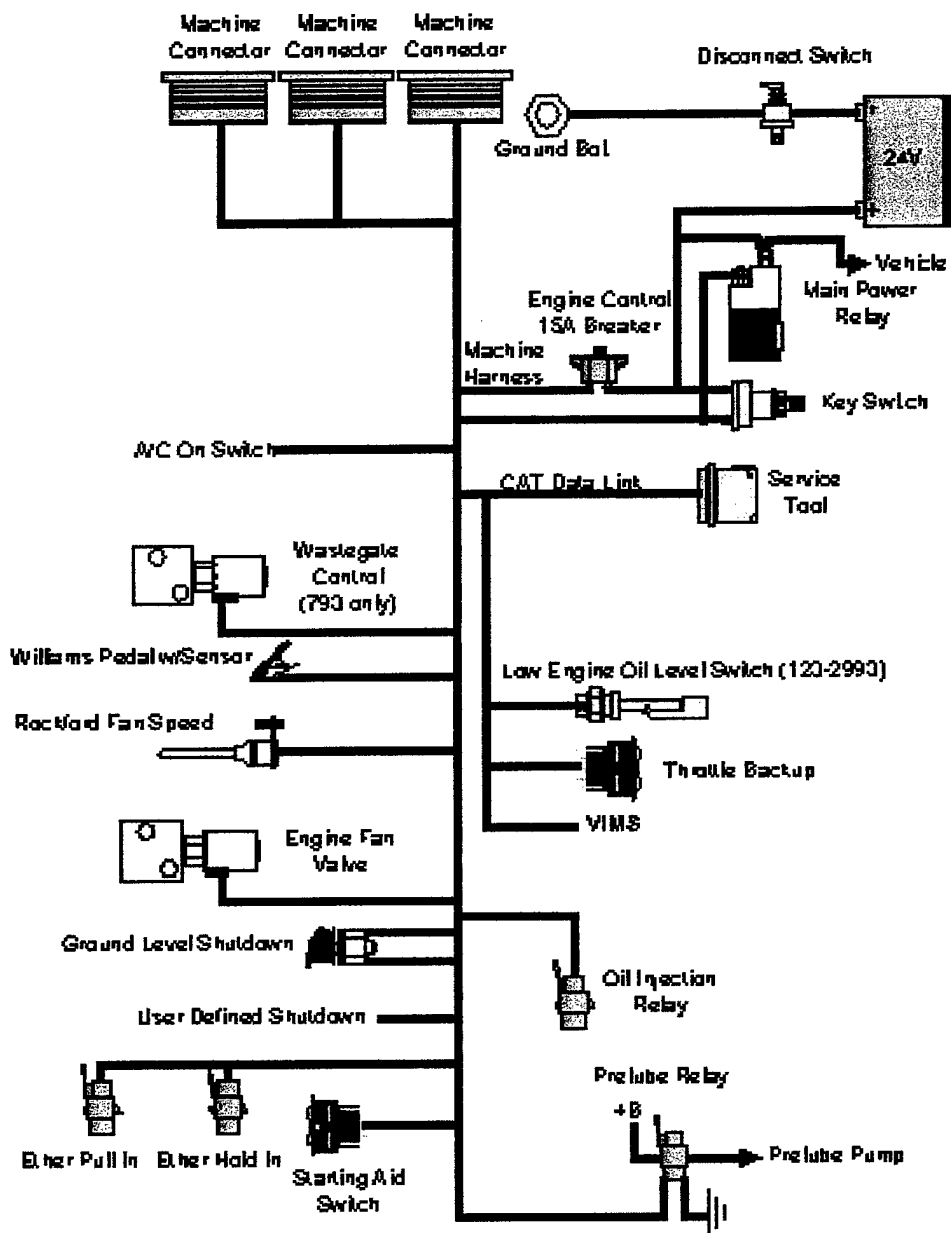
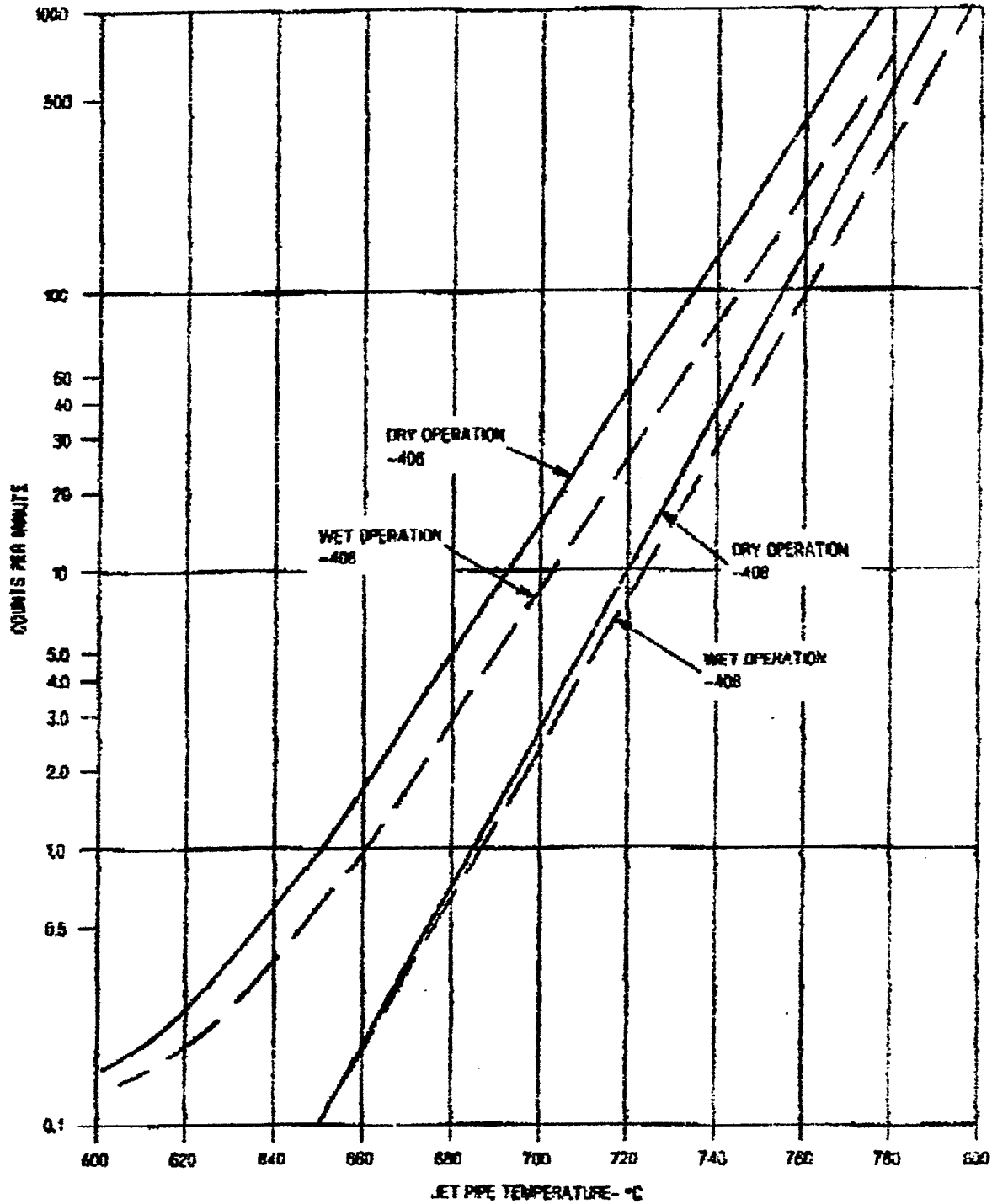

Figure 8. Production Intent Application Block Diagram

Appendix C. Counts



Appendix D. Acronym List

Acronym	Definition
CBM	Condition-Based Maintenance
DEC	Digital Electronic Control
EB	Electric Boat
FTSCLANT	Fleet Technical Support Center, Atlantic
HHD	Hand Held Devices
ICAS	Integrated Condition Assessment System
NNS	Newport News Shipbuilding
OST	Oceana Sensor Technologies
RUL	Remaining Useful Life
SBIR	Small Business Innovative Research
SHM [®]	System Health Monitor
TC	Turbo Compressor
VASCIC	Virginia Advanced Shipbuilding and Carrier Integration Center
VIMS	Vehicle Information Management System
VT/OL	Vertical Take Off and Landing

Attachment 1. Allan Lees' Article

(begins on following page)



Caterpillar Inc.

Technical Services Division
P. O. Box 1875
Peoria, Illinois 61656-1875

October 12, 2001

Mr. Lewis Watt
President
RLW Inc.
1346 South Atherton Street
State College, PA. 16801

Ref: SBIR NO1-037 - Integration of Control Systems with CBM Systems

Dear Mr. Watt:

Caterpillar is pleased with the work RLW Inc. has accomplished during Phase I of the referenced SBIR, for diesel engine turbocharger condition-based maintenance and supports the proposal for Phase II of the project.

Caterpillar will continue to provide technical support to RLW with man-hours in both our Technical Center in Peoria, IL and our Large Engine Center in Lafayette, IN for Phase II of this turbocharger CBM project. Caterpillar's Large Engine Center and Systems & Controls – R&D departments will also provide RLW Inc. with \$35,000 of matching funds upon award of the Phase II SBIR to RLW Inc. We are hopeful this funding will help assure selection of this valued project.

Please keep me informed of the progress of the project selection process, and advise me if communication directly with the Office of Naval Research will be useful. Caterpillar looks forward to continuing our work with RLW Inc. Please feel to contact me regarding this project or Paul Moots at 309-578-3712.

A handwritten signature in cursive script that reads "Michael E. Moncelle".

Michael E. Moncelle
Technology Manager
New Technology Introduction
LEC-KEC Product Development
Tech Center Bldg. F
Voice/FAX: 309-578-9913
Internet Mail Address: moncelle_michael_e@cat.com



COMMONWEALTH OF PENNSYLVANIA
OFFICE OF THE GOVERNOR
HARRISBURG

GOVERNOR'S ACTION TEAM
100 PINE STREET, SUITE 100
HARRISBURG, PENNSYLVANIA 17101
Tel: (717) 787-8199
Fax: (717) 772-5419

September 18, 2001

Mr. Lewis Watt
President
RLW Inc.
1346 South Atherton Street
State College, PA 16801

Dear Mr. Watt:

The purpose of this letter is to confirm that the Pennsylvania Department of Community and Economic Development (DCED) has made available to RLW Inc. an Opportunity Grant in the amount of \$50,000. The Opportunity Grant program has the flexibility to allow Pennsylvania to customize its assistance to the specific needs of your project. The matching component required in the Opportunity Grant program is typically compatible with other funding sources including federal programs. I believe the phase II SBIR is in consonance with the spirit and intent of the Opportunity Grant Program.

Governor Ridge has made economic development and improving Pennsylvania's business climate his highest priority. The Governor's Action Team and the DCED are vitally interested in the growth of technology-based companies in Centre County. We realize that RLW Inc's success in winning and executing the Phase II SBIR will contribute substantially to the growth of the company.

Please keep our office apprised of your progress in this endeavor.

Sincerely,

A handwritten signature in cursive script that reads "Brian R. Ross".

Brian R. Ross
Regional Director
Governor's Action Team



**NEWPORT NEWS
SHIPBUILDING**

4101 Washington Avenue
Newport News, Virginia 23607-2770
Phone: 757-380-2000
<http://www.nns.com>

September 13, 2001

RLW, Inc.
1346 S. Atherton Street
State College, PA 16801

Attention: Mr. Lewis Watt

Subject: SBIR N01-037; Integration of Control Systems with CBM Systems

Reference:

(a) Visit by RLW, Inc. to NNS on 7/20/01.

During the Reference (a) discussions, RLW, Inc. identified the need for a diesel engine to support the Phase II proposal for your subject SBIR Program. Newport News Shipbuilding (NNS) supports continuation of your SBIR project from Phase I into Phase II and proposes to utilize a NNS-owned diesel engine to support the Phase II testing program. The engine is a Volkswagen turbo-compressed diesel engine that NNS procured under Independent Research and Development and tested as a possible small submersible energy source. NNS proposes to set the engine up and test it in our recently opened Virginia Advanced Shipbuilding and Carrier Integration Center (VASCIC) laboratory.

This proposed support is contingent upon negotiation of mutually acceptable terms and conditions.

NNS looks forward to working with RLW, Inc. Please contact Scott Cummings at 757-380-3933 to initiate contractual negotiations.

Sincerely,

W. Floyd, Jr.
Manager, Submarine Technology

CONDITION MONITORING AND VIBRATION ANALYSIS OF DIESEL GENERATORS WITH AN EMPHASIS ON TURBOCHARGERS

July 26, 2001

Prepared for:

**Lewis Watt
RLW Inc.
State College PA**

Prepared by:

Allan J. Lees, P. Eng.

DYNAMIC SIGNAL ANALYSIS INTERNATIONAL CORP.



**BC Research Building
3650 Wesbrook Mall
Vancouver BC Canada V6S 2L2
Phone: 604-221-5300 Fax: 604-221-1022 Email: alees@direct.ca**

TABLE OF CONTENTS

1.0 INTRODUCTION.....	1
2.0 GENERAL DESCRIPTION OF TURBOCHARGER ROTOR DYNAMICS AND DESIGN.....	5
3.0 TURBOCHARGER OPERATING EXPERIENCE.....	7
4.0 DIAGNOSTIC AND TROUBLE SHOOTING METHODS.....	11
5.0 CONDITION ASSESSMENT PROCEDURE--VIBRATION ANALYSIS	12
6.0 ASSESSING THE SEVERITY OF VIBRATION	14
6.1 COMPARISON AMONG SIMILAR UNITS.....	14
6.2 COMPARISON AMONG VIBRATION SEVERITY STANDARDS	14
6.3 OTHER VIBRATION SEVERITY STANDARDS AND SOME EXAMPLES OF STANDARD INDUSTRY PRACTICE.....	15
6.4 VIBRATION STANDARDS SURVEY—CONDUCTED BY THE NATIONAL RESEARCH COUNCIL OF CANADA.....	17
3.5 US COAST GUARD AND OTHER SHIPBOARD VIBRATION SEVERITY STANDARDS	17
6.6 LLOYDS REGISTER GUIDELINES	19



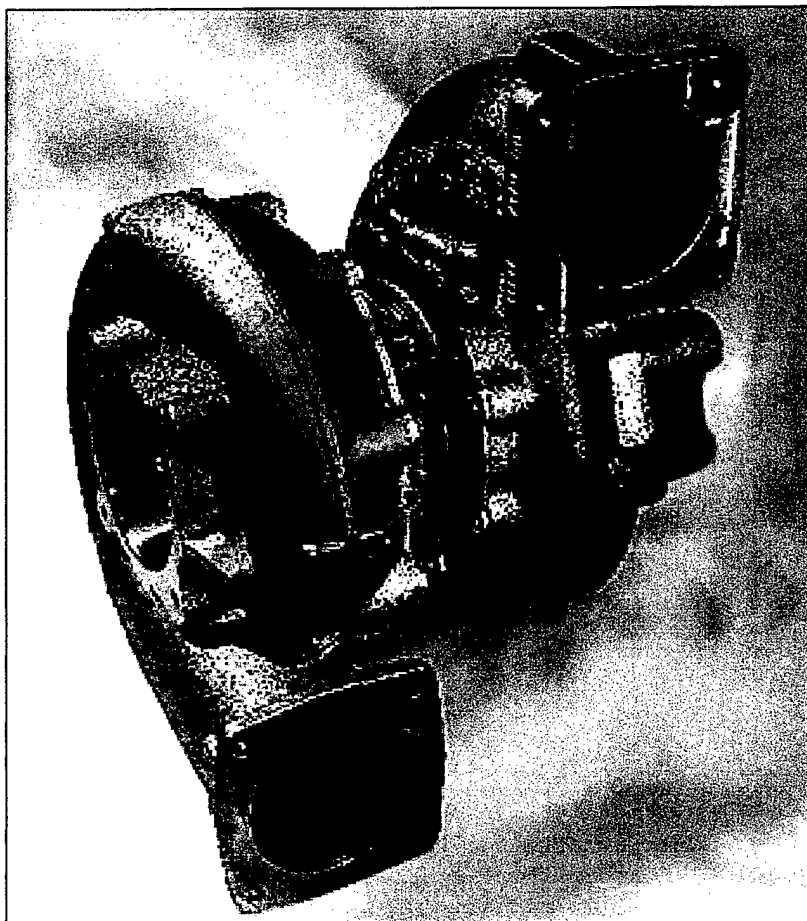

Figure 1.2 Photograph of ABB Type RR Turbocharger

1.0 INTRODUCTION

DSA International engineers working in conjunction with personnel from RLW Inc. of State College PA were asked to outline an instrumentation system to monitor the health of the turbochargers on various Caterpillar diesel generation systems operating on US Navy vessels. The three classes of generators include models 3512, 3608 and 3616. The 3500 series engine commonly use an ABB type RR151 turbocharger whereas the 3600 series engines use an ABB type VTC254.

Both the RR and VTC series turbochargers are fitted with internal bearings meaning that the turbine and compressor wheels are mounted outboard of the two support bearings. The RR series has a radial turbine and the VTC has an axial turbine. Figures 1.1 and 1.2 show the RR turbocharger and Figures 1.3 and following show drawings and photographs of the type VTC turbocharger.

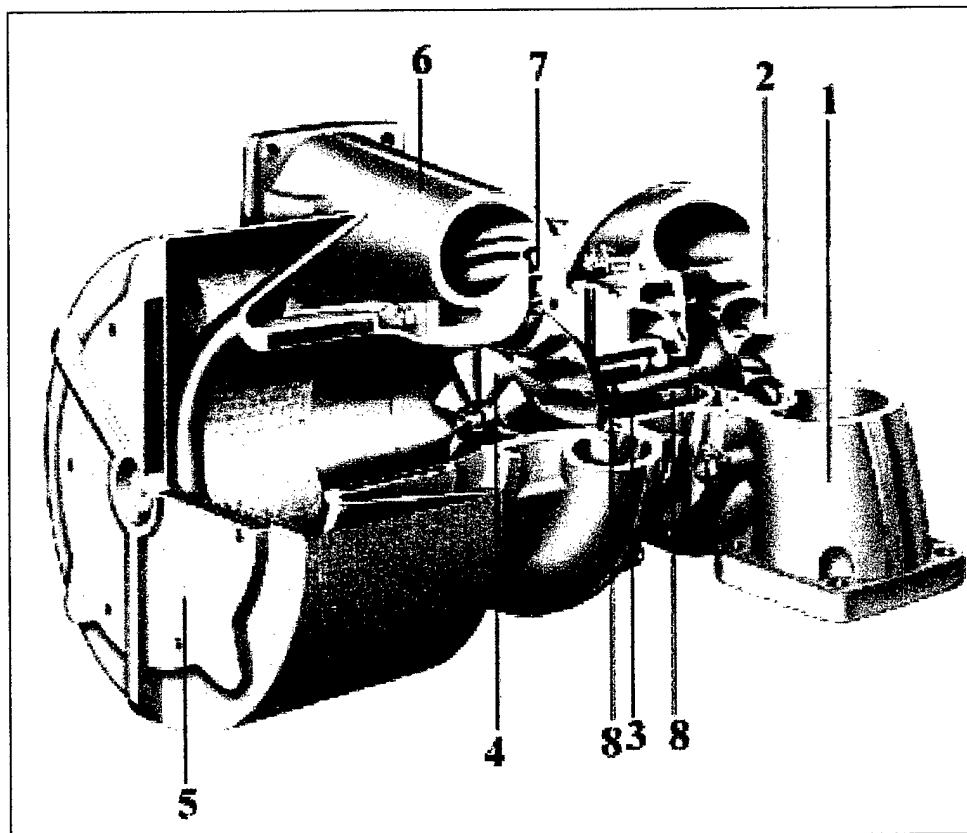

Figure 1.1 Cutaway of ABB Type RR Turbocharger



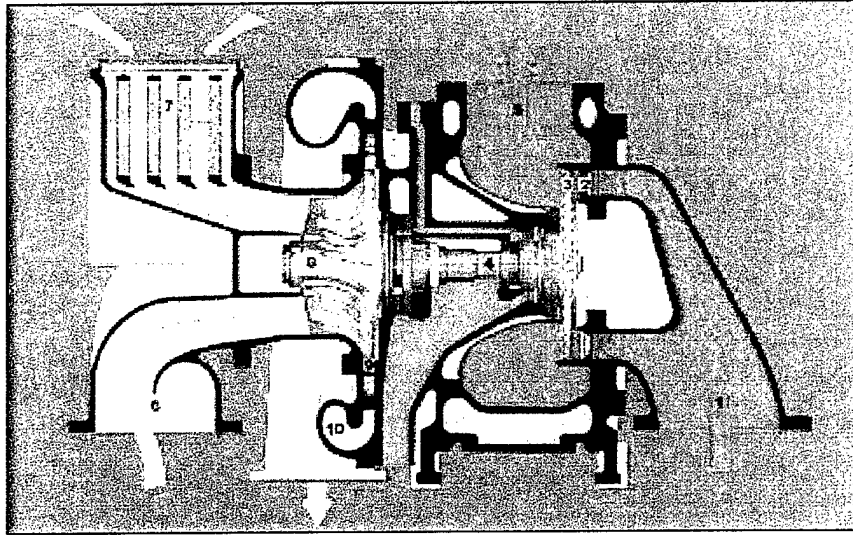

Figure 1.3 Cutaway of an ABB Type VTC Turbocharger

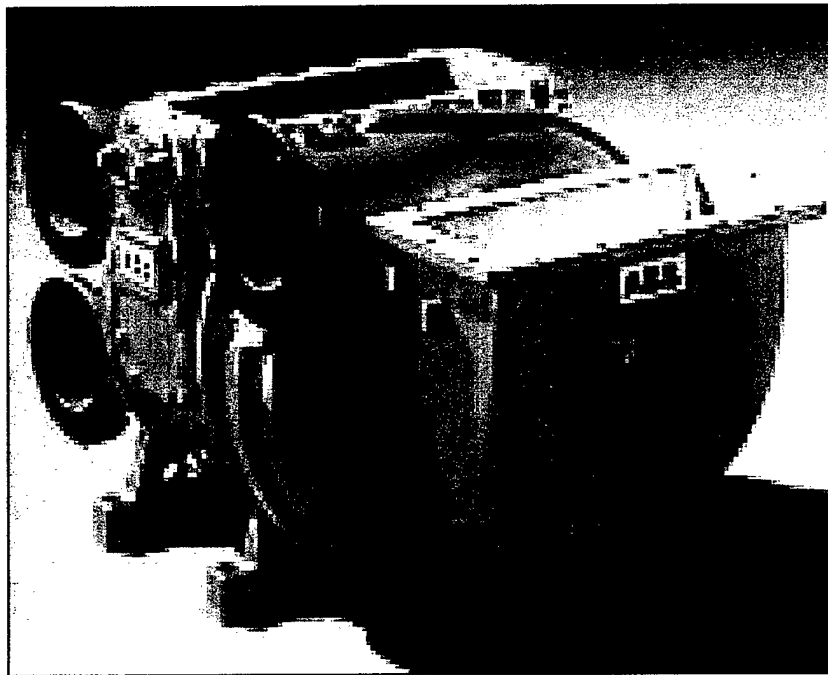

Figure 1.4 Photograph of an ABB Type VTC Turbocharger



Figure 1.5 ABB Type VTC Turbine Wheel



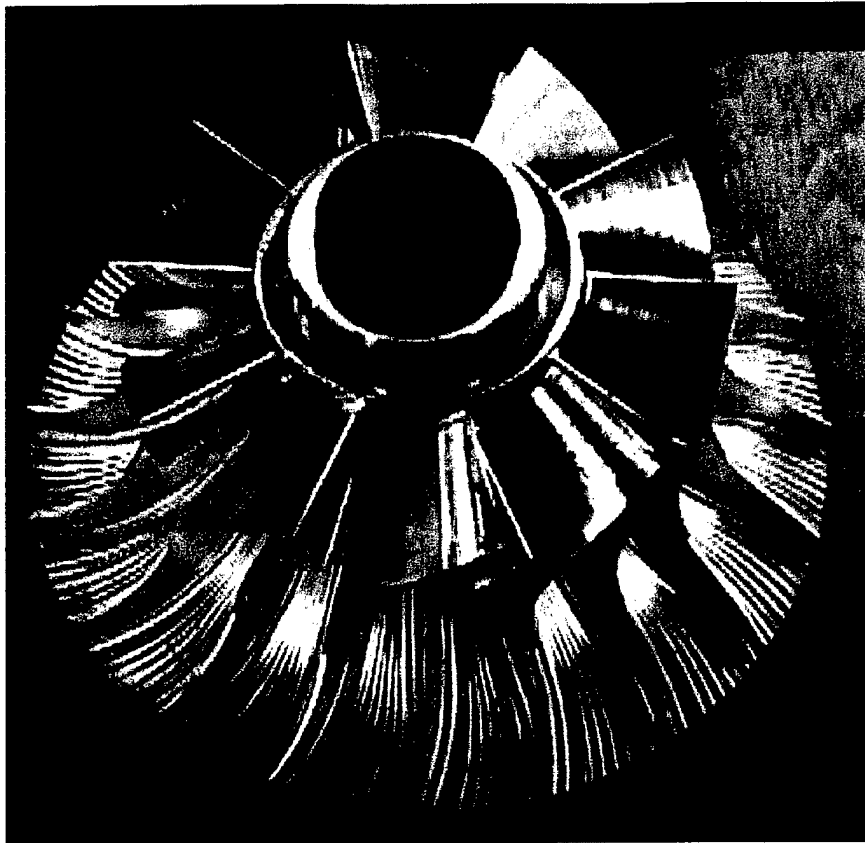

Figure 1.6 ABB Type VTC Compressor Wheel

2.0 GENERAL DESCRIPTION OF TURBOCHARGER ROTOR DYNAMICS AND DESIGN

In order to keep the frictional losses low turbochargers are designed with as small a shaft as possible. For internal bearing arrangements (as in the RR and VTC turbochargers) journal bearings are generally used. These have a floating bush and fixed mounting of the bearing body.

In larger engines the VTR series of turbochargers are used. These have external rolling element bearings since the ends of the shaft can be kept small. They are four lobe bearings with damping springs. Figure 2.1 below shows a drawing of the type VTR turbocharger.

With any of these designs the dynamic behaviour of the rotor is extremely complex. The rotor is excited by both plain bearing vibration as well as vibration from the engine. This can lead to sub-harmonic oscillations. To reduce this effect the bearings are resiliently mounted in a spring pack, however even a small amount of unbalance can lead to considerable shaft deflection and significant bearing forces.



In fixed shore based diesel generator applications running at constant speed the turbochargers are generally very reliable. However, in shipboard application the situation quite different since the turbine rotor which is spinning at high speed will generate substantial gyroscopic forces when the ship rolls (or pitches depending upon turbocharger shaft orientation). This can lead to large shaft deflections and high bearing forces. These forces are particularly large in internal bearing turbochargers owing to the short distance between support bearing centerlines. Add to these forces are others such as asymmetric gas pulsation. The need for large bearing clearances becomes apparent since all the forces acting on the bearing are cumulative. Unfortunately large clearances to accommodate the cumulative forces leads to higher losses. A trade off is generally arrived at wherein the bearing clearances are reduced to the point where the losses are acceptable with the bearing having sufficient clearance to accommodate most shore based operating situations. On a vessel doing high speed maneuvering the situation is much more complex.

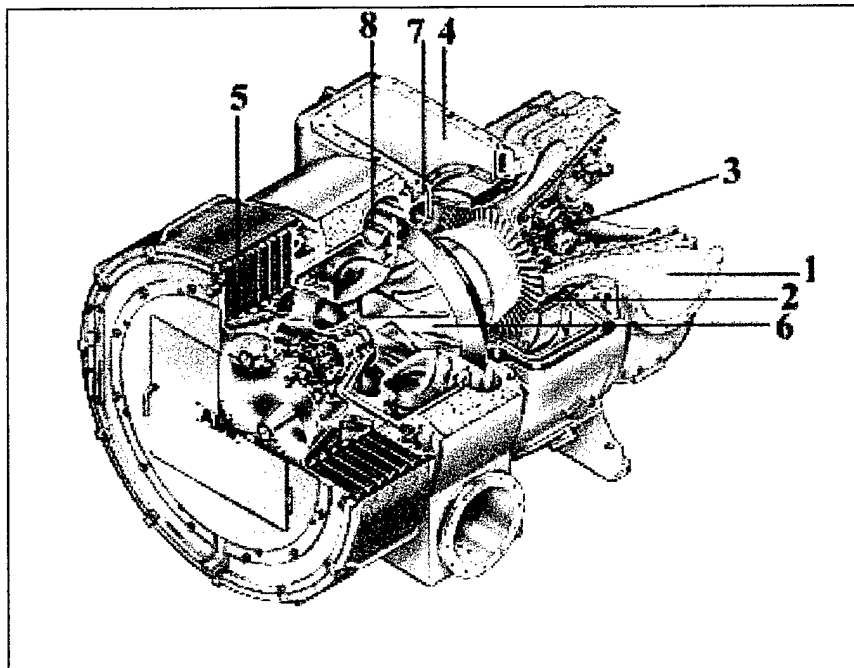

Figure 2.1 ABB Type VTR Turbocharger



3.0 TURBOCHARGER OPERATING EXPERIENCE

Turbochargers are designed to last approximately 8,000 to 16,000 hours. In our experience turbochargers that are used in shipboard diesel generator applications may, for many different reasons, last substantially less than that period of time. For a VTR series turbocharger mounted on a 9 cylinder Bergen diesel generator used in a passenger and car carrying ferry the turbochargers began failing in a few hundred hours. The "normal" life was expected to be 8,000 hours. Our engineers pinpointed the source of the problem as casing distortion caused by high engine and exhaust bellows vibration. Adding a more flexible bellows, improving the exhaust hangers, stiffening the turbocharger mounting system and switching to a steel housing from the original aluminum alloy housing improved the turbocharger life substantially.



Figure 3.1 Type VTR Turbocharger Mounted on a 9 Cylinder Bergen Diesel Generator Set on Board a Passenger and Car Carrying Ferry



Figures 3.2 and following show the modal testing (using an impact hammer) and the turbocharger operating deflection shapes mode shapes.. Photographs of failed bearings are also shown..

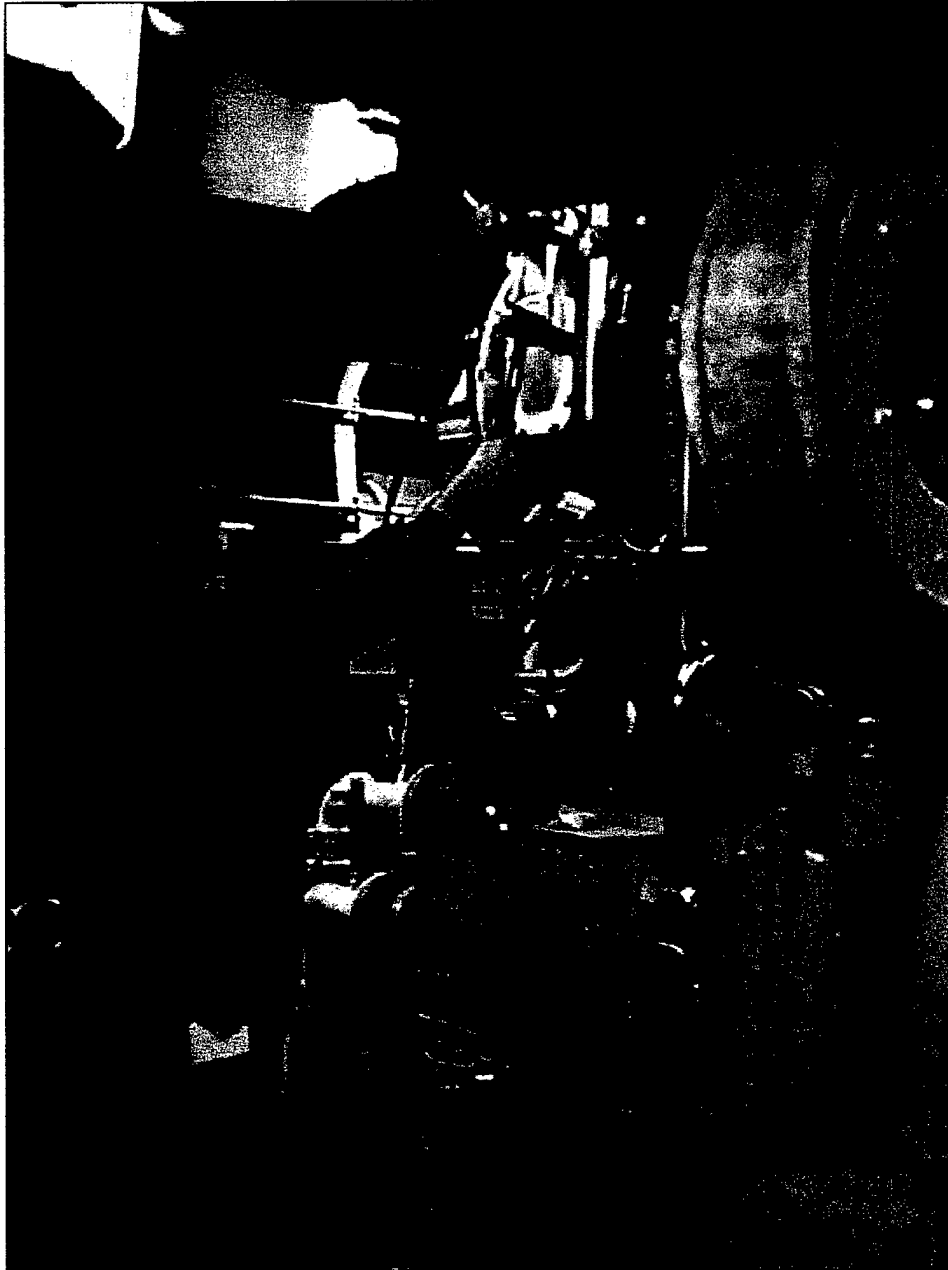

Figure 3.2 Modal Analysis Testing With Force Hammer



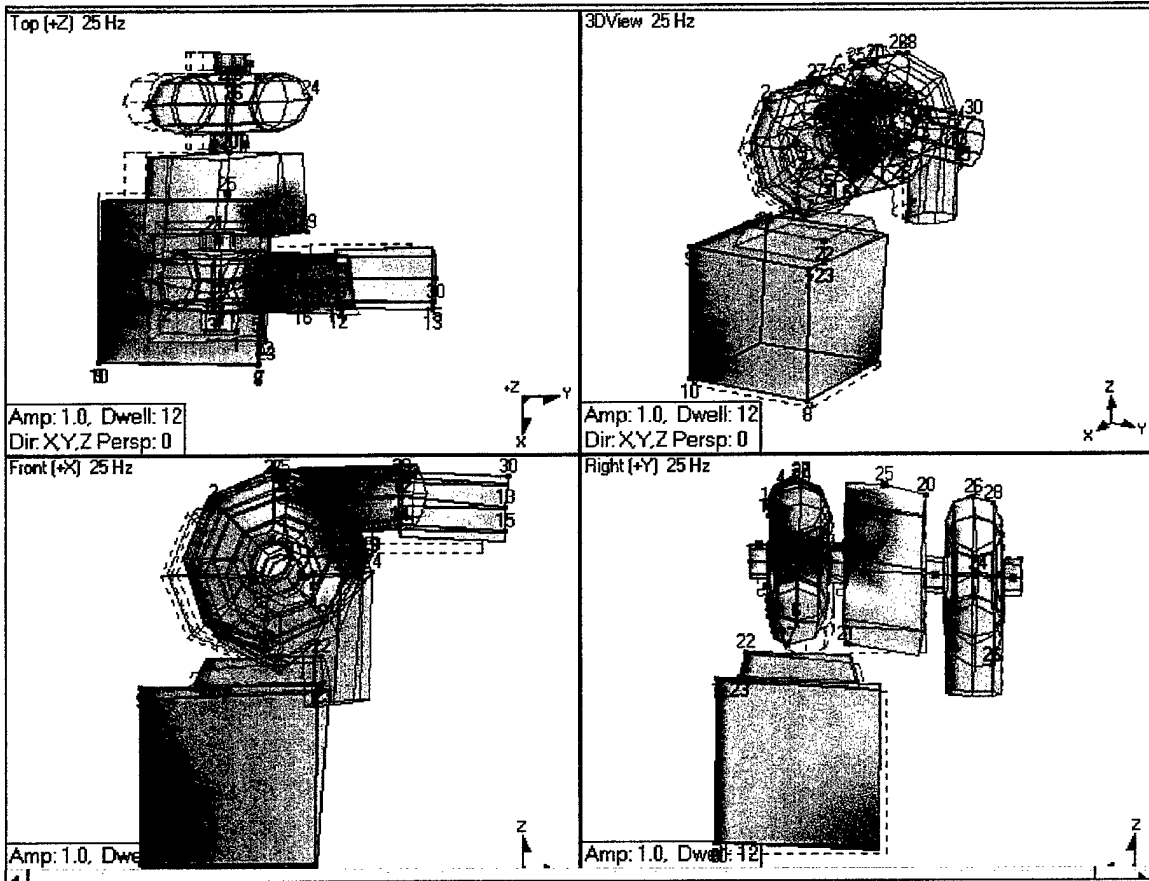

Figure 3.3 Typical Modal Analysis Results Showing the Top, Side, Front and 3D Views of the Turbocharger and Mounting Structure (Simplified)



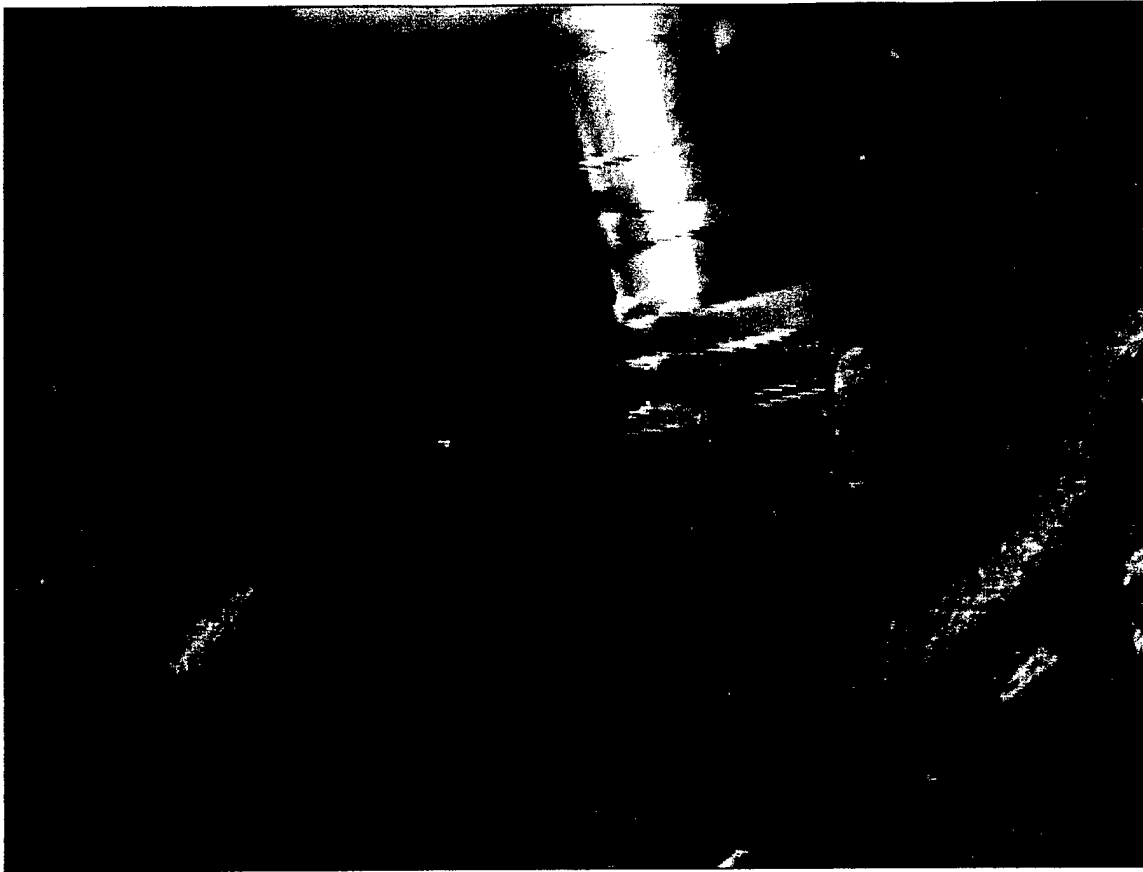

Figure 3.4 Failed Turbocharger Roller Bearing



In a sewage plant cogeneration facility the turbochargers on Caterpillar 3516 diesels have operated reliably for 7,000 to 10,000 hours. Experience varies from one user to the next. Figure 3.5 shows a Caterpillar 3516 diesel generator set powered by methane and natural gas.

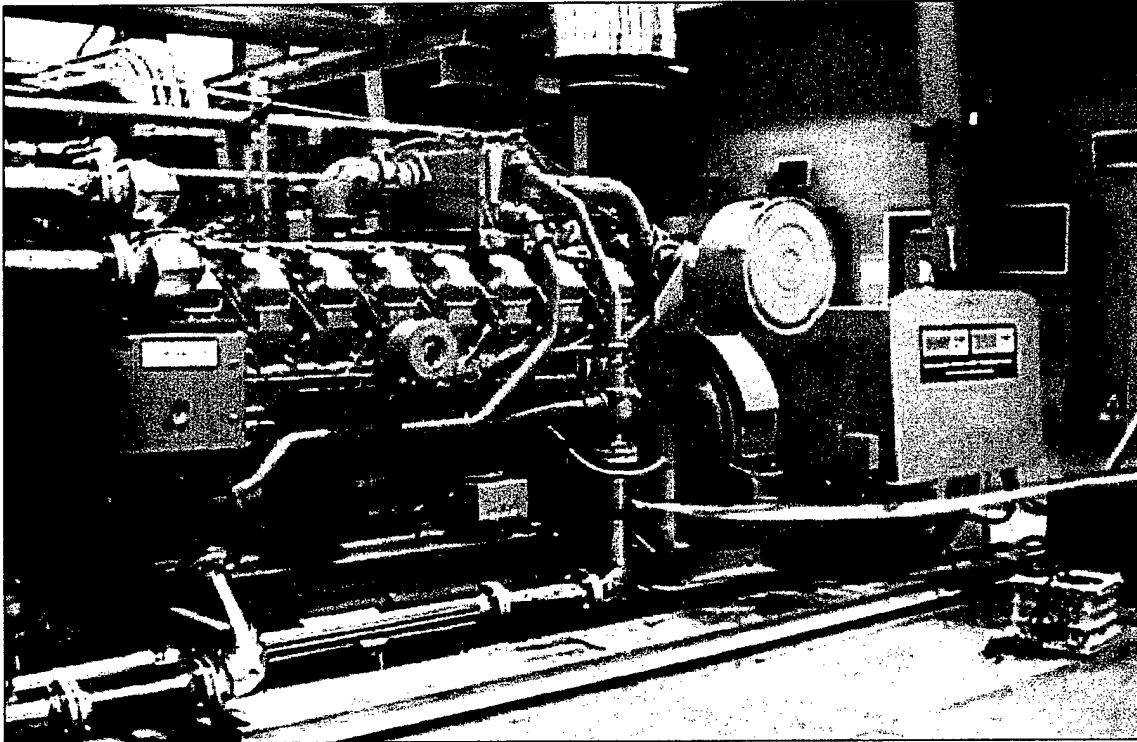

Figure 3.5 Caterpillar 3516 Co-generation Set in Sewage Plant

4.0 DIAGNOSTIC AND TROUBLE SHOOTING METHODS

Although performance based analysis using inlet and outlet temperatures, pressures speeds etc are useful in assessing the overall efficiency of the turbocharger, these parameters do little to provide advance warning of impending turbocharger failure. In our experience vibration analysis combined with periodic oil analysis is a powerful tool for assessing the current health of the turbocharger and for other parts of the diesel generator set. However, simple overall vibration velocity does not give much useful information. Broad band time domain signals and frequency spectra are the principal tools needed to determine if there is any deterioration of machine condition.



5.0 CONDITION ASSESSMENT PROCEDURE--VIBRATION ANALYSIS

Analysis of the frequency spectrum of vibration has proven to be a reliable method of assessing the mechanical health of a piece of machinery. The vibration data was collected with a Hewlett Packard 3560A Dynamic Signal Analyzer using an accelerometer (vibration sensor) attached to the machine at each measurement location with a strong magnet. These are the same measurement locations as were used when we had collected data in previous years. The measurement locations were chosen to be as close to the bearing points on the machine components as possible. Namely on either end of the generator, at several locations on the gearbox, as well as the engine base plate, camshaft gear case, lube oil pump and turbocharger. Vibration data was collected on the cogeneration units at various conditions from no load up to full load. Figure 5.1 below shows the measurement locations and figure 5.2 shows typical vibration spectra and trended vibration data.

Once the vibration data has been collected it is analyzed using DSA International Corporation's Check-Mate expert system software. Information such as the bearing numbers, the number of teeth on each of the gears, the engine rotation speed, turbocharger rotation speed etc. have been added to the knowledge base of Check-Mate. When this information is entered into Check-Mate, it can then used as an aid in finding impending mechanical problems in the engine, gearbox, or generator.

Since vibration data has previously been collected on these cogeneration units, our engineers were able to compare the current vibration patterns with those taken previously and with factory bench tests.



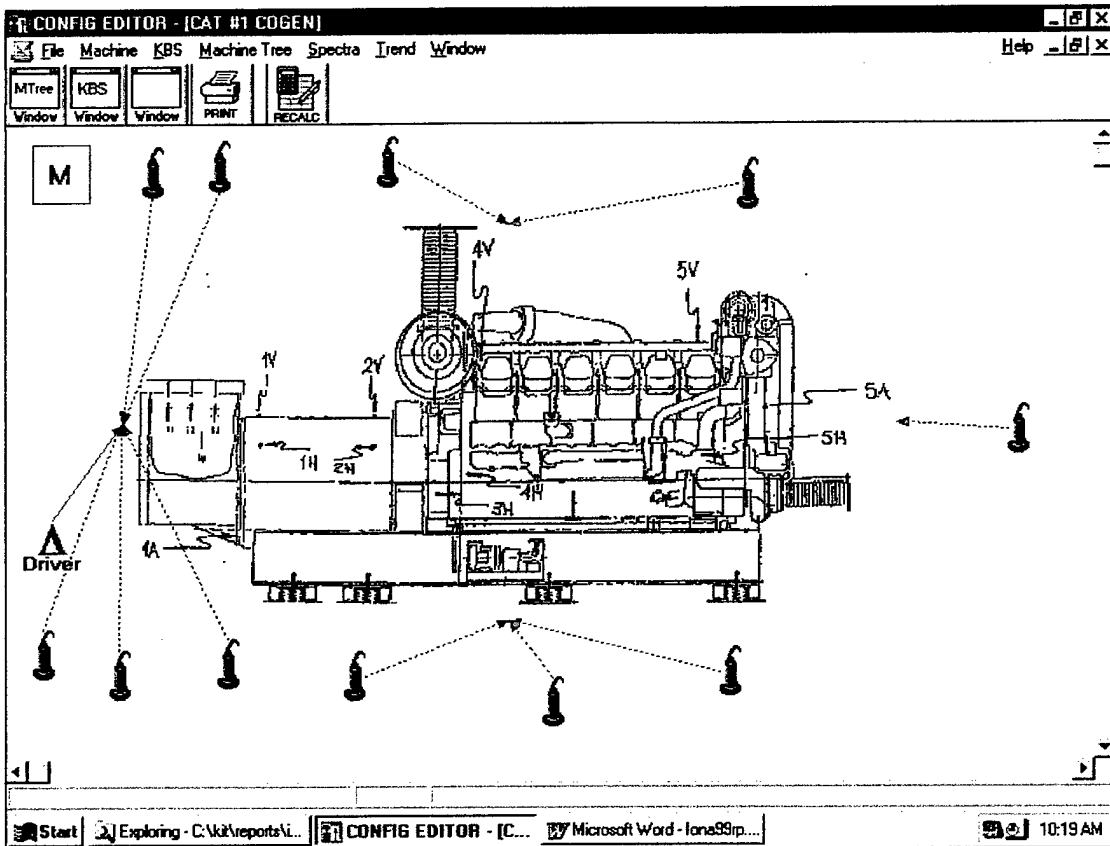
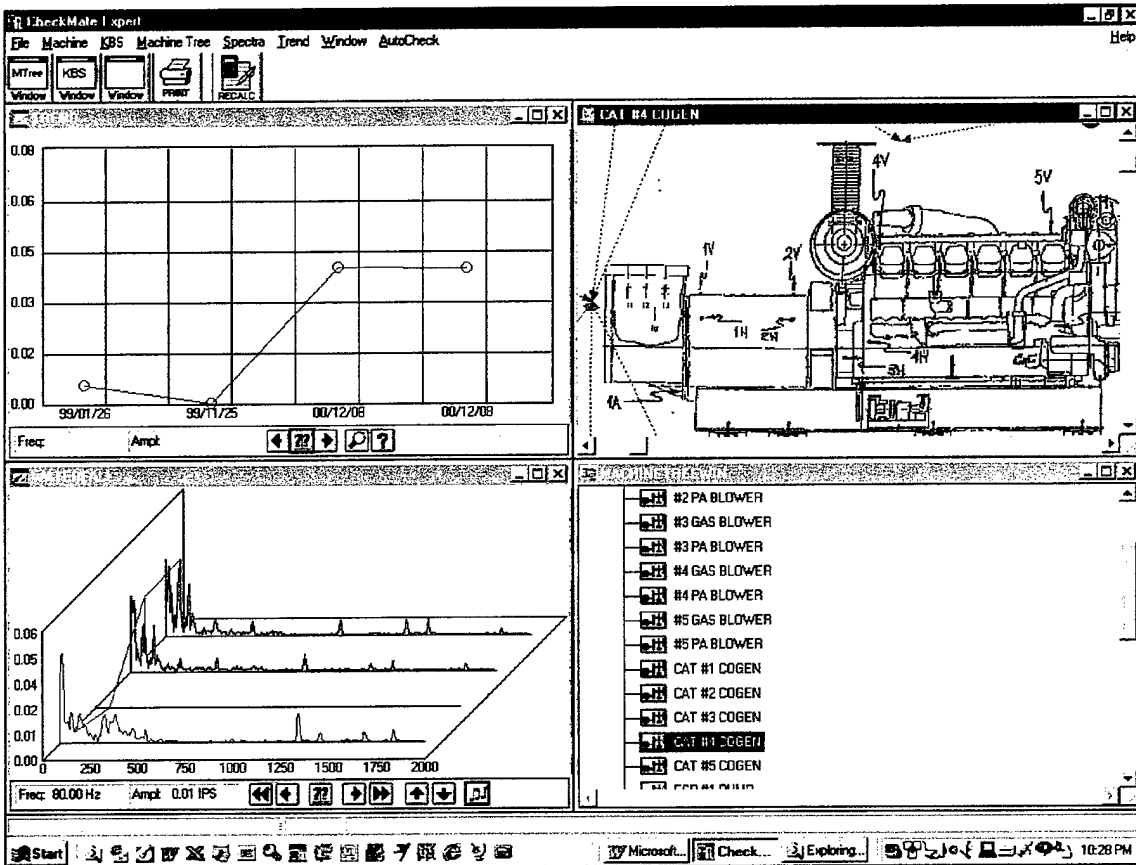

Figure 5.1 Measurement Locations for the Cogeneration Units





5.2 Typical Vibration Spectra and Trend Taken in the Vertical Direction on the Front End of the Engine

6.0 ASSESSING THE SEVERITY OF VIBRATION

This can be done in several ways as listed below:

6.1 COMPARISON AMONG SIMILAR UNITS

One of the most effective methods of assessing the health of equipment is to compare each unit's vibration patterns with those of other identical units. Any significant difference in the vibration pattern between any of the units would be an indication of possible mechanical problems.

6.2 COMPARISON AMONG VIBRATION SEVERITY STANDARDS

One of the more common is the ISO 8528-9 Standard entitled "Reciprocating internal combustion engine driven alternating current generating sets--- Part 9 Measurement and Evaluation of Mechanical Vibrations".



We have summarized the relevant portions of the standard from Table C.1. Our purpose in doing so was to enable us to contrast this with standard industry practice and other international standards in common use in industry. Table 6.2.1 summarizes Table C.1 of ISO standard 8528-9.

Table 6.2.1 ISO 8528-9 "Reciprocating internal combustion engine driven alternating current generating sets--- Part 9 Measurement and evaluation of mechanical vibrations".

Engine Speed in RPM	Power in kW	Engine Vibration Velocity in RMS mm/sec	Generator Vibration Velocity in RMS mm/sec	Generator Vibration Velocity in RMS mm/sec
			Value 1 Notes 1 and 2	Value Notes 2 and 3
>2000 but <3600	>40		40 Note 4	50 Note 4
>1300 but <2000	>100 but <200	45	25	30
	>200		20	28
>720 but <1300	>200 but <1000	45	20	24
	>1000	45	18	22
<720	>1000	45	15	20

Notes:

1. If vibration is below Value 1 damage not expected
2. Vibration between Value 1 and Value 2 assessment of generator set components may be required along with an agreement between the generating set manufacturer and the component supplier in order to ensure reliable operation.
3. Vibration levels can be above value 2 but only if individual specific designs of generating set structure and components are applied.
4. These levels are subject to agreement between the manufacturer and the customer.

6.3 OTHER VIBRATION SEVERITY STANDARDS AND SOME EXAMPLES OF STANDARD INDUSTRY PRACTICE

Other international standards (notably ISO 3945 and 2372 as well as VDI 2056 and BS 4675) can be used for assessing the severity of the rotating machinery. Since these standards have been specifically developed for rotating machinery operating between 10 and 200 revs per second they could only be used for assessing the health of the



generator. Table 3.3.1 below shows the vibration severity permissible under the ISO 3945 for large machinery above 400 HP. Since the generator and the gearbox are rigidly supported the center column is applicable.

Table 6.3.1 Vibration Severity Allowable Limits Per ISO Standards 3945 and 2372

Severity	Vibration Limits (in IPS)	Vibration Limits (in IPS)
	Rigidly Supported	Softly Supported
Good	0 to 0.071	0 to 0.11
Satisfactory	.071 to 0.18	0.11 to 0.28
Unsatisfactory	0.18 to 0.44	0.28 to 0.71
Unacceptable	above 0.44	above 0.71

Some examples of current industry practice are referred shown in Table 6.3.2 below:

Table 6.3.2 Industry Practice for Reciprocating Engine Powered Generators

	Northern Canada Power Commission Diesel Generators	BC Hydro Diesel Generators Based on Recommendations From the Electro Motive Division Of General Motors	Canadian Government Specification CDA/MS/ NVSH107
(Vibration Velocity in Inches per Second)			
Generator Bearings	0.33 peak 0.23 RMS	0.33 peak desirable 0.23 RMS desirable	
Reciprocating Engine Block		0.50 peak max. 0.36 RMS max.	
Gears	0.44 peak	0.5 peak desirable	
Coolant pump	0.33 RMS	0.36 RMS desirable	
Turbocharger		1.0 peak maximum 0.71 RMS maximum	
Instrument Panels	0.09 peak 0.06 RMS		
Skid and Sub-Base	0.77 peak horiz. 0.55 RMS horiz. 0.55 peak vert. 0.40 RMS vert..	0.33 peak horiz. Desirable 0.23 RMS horiz desirable 0.50 peak horiz maximum 0.36 RMS horiz. Maximum 0.25 peak vert. Desirable 0.18 RMS vert desirable 0.40 peak vert. Maximum 0.28 RMS vert maximum	
Piping, heat Exchangers,	0.77 peak 0.55 RMS		
Floor Slab	0.11 peak 0.08 RMS		



Complete Diesel Generator			0.055 for long life 0.39 for short life 0.71 recondition 1.26 after recond.
---------------------------	--	--	--

6.4 VIBRATION STANDARDS SURVEY—CONDUCTED BY THE NATIONAL RESEARCH COUNCIL OF CANADA

In 1994 the National Research Council of Canada conducted a fairly extensive survey of vibration standards with 62 organizations participating. This survey included small, medium and large diesel generators. It did not specifically include spark ignition engines. The results for diesel generators are excerpted below:

Table 6.4.1 NRC Vibration Guidelines Survey for Diesel Engines and Gearboxes

Size	KW	Speed in RPM	Normal Vibration	Alarm Vibration Level	Shut Down Vibration Limit
Large Diesel Generators		1200 to 1800	20 mm/sec absolute	30 mm/sec absolute	40 mm/sec absolute
Medium Diesel Generators	5200	300		8 mm/sec peak rel	13 mm/sec peak rel
		1200 to 1800	20 mm/sec absolute	30 mm/sec absolute	40 mm/sec absolute
Small Diesel Generators	373	1750	25-38 μ meter		76 μ meter
Large gearboxes			2mm/sec RMS	5mm/sec RMS	
Medium gearboxes	200	1800	4mm/sec peak	8mm/sec peak	16mm/sec peak
	37	30	3mm/sec RMS	6mm/sec RMS	
Small Gearboxes	7	150	4mm/sec RMS	7mm/sec RMS	

3.5 US COAST GUARD AND OTHER SHIPBOARD VIBRATION SEVERITY STANDARDS



There are a number of torsional and longitudinal vibration severity standards that are applied to vessels around the world.

- MIL-STD-167-2 (SHIPS) "Mechanical Vibrations of Shipboard Equipment"
- SNAME T&R Code C-5 "Acceptable Vibration of Marine Steam and Heavy Duty Gas Turbine Main and Auxiliary Plants"
- ISO 10816 / 6-1995 "Mechanical Vibration – Evaluation of machine vibration by measurements on non-rotating parts-Part 6: Reciprocating machines with power ratings above 100kW"
- MIL-STD-2048 (SH) "Mechanical Vibration of Naval Diesel Generator Sets"

Other organizations and classification societies such as Det Norske Veritas, Lloyds Register of Shipping, Germanischer Lloyd, Nippon Kanji Kyokai have issued a variety of guidelines, criteria and rules for shipboard vibration.

There are a broad variety of standards and guidelines that could be used to assess the severity of vibration on conventional and non-conventional drives . Faced with the task of assessing the severity of vibration on numerous vessels, the US Coast Guard has attempted to rationalize some of the classification society guidelines with both MIL-STD-167 and the SNAME guidelines. The result of their efforts has been their proposed draft vibration severity standard for conventional and non-conventional ships Their recommendations for longitudinal vibration are as follows:

Table 6.5.1 US Coast Guard Draft Vibration Severity Limits

Part	Vibration Velocity in mm/sec Broadband RMS	Vibration Velocity in inches per second Broadband RMS
Shaft Bearing	7	0.3
Bull Gear Hub	5	0.2
Other Parts	13	0.5
Diesel <1000 HP Cylinder Head	13	0.5
Diesel >1000 HP Cylinder Head	18	0.7
Diesel Bearings all sizes	13	0.5
Thrusters Intermittent	18	0.7
Thruster Continuous	10	0.4
Waterjets	10	0.4
Separate Gearboxes	10	0.4



6.6 LLOYDS REGISTER GUIDELINES

The guidelines used by Lloyds Technical Investigation Department to assess the severity of shipboard vibration for reciprocating machines are shown below. They give the maximum peak overall vibration amplitudes in the 2-100 Hertz band.

Table 6.6.1 Lloyd's Register Overall Peak Vibration Guidelines

Displacement	+/- 0.4mm
Velocity	+/- 25 mm/sec
Acceleration	+/- 40 m/sec

The Lloyds Technical Investigation Team also use some more specific guidelines that recognize the importance of the frequency at which the vibration occurs.

Table 6.6.2 Lloyds Register Peak Vibration Severity Levels for Frequency Range 1 to 10 Hertz and 10 to 100 Hertz

Severity	Allowable Vibration Levels Over Frequency Range 1-10 Hertz	Allowable Vibration Level Over Frequency Range 10-100 Hertz	Comments
Recommended	Below 0.4 mm	Below 25 mm/sec	Below 10 Hertz use displacement limits and above 10 Hertz use velocity limits
Caution Zone	0.4 mm to 1mm	25 to 70 mm/sec	"
Damage Probable	Above 1mm	Above 70 mm/sec	"



REPORT DOCUMENTATION PAGE

Form Approved
OMB No. 0704-0188

Public reporting burden for this collection of information is estimated to average 1 hour per response, including the time for reviewing instructions, searching data sources, gathering and maintaining the data needed, and completing and reviewing the collection of information. Send comments regarding this burden estimate or any other aspect of this collection of information, including suggestions for reducing this burden to Washington Headquarters Service, Directorate for Information Operations and Reports, 1215 Jefferson Davis Highway, Suite 1204, Arlington, VA 22202-4302, and to the Office of Management and Budget, Paperwork Reduction Project (0704-0188) Washington, DC 20503.

PLEASE DO NOT RETURN YOUR FORM TO THE ABOVE ADDRESS.

1. REPORT DATE (DD-MM-YYYY) 31-10-2001		2. REPORT DATE Report Type: Final		3. DATES COVERED (From - To) May 2001 to October 2001	
4. TITLE AND SUBTITLE SBIR N01-037: Technology for Shipboard Affordability. "Integration of Control Systems with CBM (Condition Based Maintenance) Systems" (UNCLAS)				5a. CONTRACT NUMBER N00014-01-M-0151	
				5b. GRANT NUMBER	
				5c. PROGRAM ELEMENT NUMBER	
6. AUTHOR(S) Lewis Watt				5d. PROJECT NUMBER	
				5e. TASK NUMBER	
				5f. WORK UNIT NUMBER	
7. PERFORMING ORGANIZATION NAME(S) AND ADDRESS(ES) RLW, Inc. 1346 South Atherton Street State College, PA 16801				8. PERFORMING ORGANIZATION REPORT NUMBER 0001 AD Final Report	
9. SPONSORING/MONITORING AGENCY NAME(S) AND ADDRESS(ES) Office of Naval Research, Code 361 Ballston Tower One 800 North Quincey Street Arlington, VA 22217-5660				10. SPONSOR/MONITOR'S ACRONYM(S) ONR	
				11. SPONSORING/MONITORING AGENCY REPORT NUMBER	
12. DISTRIBUTION AVAILABILITY STATEMENT Approved for Public Release; SBIR report, distribution unlimited.					
13. SUPPLEMENTARY NOTES Report developed under SBIR contract for Topic N01-037: "Technology for Shipboard Affordability"					
14. ABSTRACT The goal of this SBIR Phase I was to develop a design for a condition based maintenance (CBM) system applicable to some components of large diesel generator sets such as those powered by Caterpillar series 3500 and 3600 engines. The SBIR effort was to integrate the CBM system with current or planned digital engine control (DEC) systems in the manner that would have the most positive effect on life cycle cost. Early in the project, the turbo compressor (TC) components were selected as most appropriate for the application based on several reviews of failure frequency and seriousness and of commercialization potential. The resulting design will extract data from the DEC as well as employing... (continued on next page)					
15. SUBJECT TERMS Condition Based Maintenance; Life Cycle Cost; Wireless; Smart Sensor; Turbo Compressor; Diesel Generator; Sensors; Maintenance					
16. SECURITY CLASSIFICATION OF:			17. LIMITATION OF ABSTRACT	18. NUMBER OF PAGES	19a. NAME OF RESPONSIBLE PERSON
a. REPORT	b. ABSTRACT	c. THIS PAGE			Lewis Watt
U	U	U	UU	48	19b. TELEPHONE NUMBER (include area code) 814-867-5122

(abstract continued from previous page)...three or four small, smart, wireless sensors to supplement the DEC data. The wireless sensors will perform substantial data reduction at the sensor, sending the resulting information to a next level processor (the health processor) for additional processing and/or comparison with other inputs. Where the DEC offers sufficient processing capacity, it will serve as the health processor; if no DEC is installed, or insufficient capacity is available, a PC/104 based processor will be installed. The wireless sensors and the health processor will be capable of sending TC health information wirelessly to hand-held devices and to the ship's or facility's local area network.

The resulting design will be prototyped in Phase II. Excellent commercial acceptance is anticipated.