

ARMY RESEARCH LABORATORY

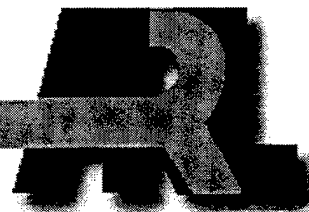

# Experimental Validation of Elliptical Fin Opening Behavior

James M. Garner  
Paul Weinacht  
Robert P. Kaste

ARL-TR-2527

SEPTEMBER 2001

20011102 069

The findings in this report are not to be construed as an official Department of the Army position unless so designated by other authorized documents.

Citation of manufacturer's or trade names does not constitute an official endorsement or approval of the use thereof.

Destroy this report when it is no longer needed. Do not return it to the originator.

**Army Research Laboratory**  
Aberdeen Proving Ground, MD 21005-5066

---

ARL-TR-2527

September 2001

---

## Experimental Validation of Elliptical Fin Opening Behavior

James M. Garner  
Paul Weinacht  
Robert P. Kaste  
Weapons & Materials Research Directorate

---

Approved for public release; distribution is unlimited.

---

---

## Abstract

---

An effort to improve the performance of ordnance has led to the consideration of the use of folding elliptical fins for projectile stabilization. A second order differential equation was used to model elliptical fin deployment history and accounts for deployment with respect to the geometric properties of the fin, the variation in fin aerodynamics during deployment, the initial yaw effect on fin opening, and the variation in deployment speed based on changes in projectile spin. This model supports tests conducted at the Transonic Experimental Facility, Aberdeen Proving Ground, Maryland, which examined the opening behavior of these uniquely shaped fins. A companion boat tail configuration is created by sectioning the projectile base and joining with the fin. The configuration is both space efficient and aerodynamic. Reduced drag coefficients have been documented for this configuration and it is employable on a variety of projectiles. The fins use the centrifugal force from the projectile spin to deploy. During the deployment, the fin aerodynamic forces vary with angle-of-attack changes in the free stream. Model results indicate that projectile spin dominates the initial opening rates and that aerodynamics dominate near the fully open state. Vibratory fin motions after elastic and inelastic collisions with the fin stop are also examined. The aerodynamics and initial state conditions correspond to a zone 7w artillery firing (roughly Mach 2.25) that uses a slip band obturator and with muzzle exit yaws of 0 and 5 degrees. The model results are examined to explain the observed behavior and to suggest improvements for later designs.

## ACKNOWLEDGMENTS

The origination of this design is an adaptation of a fin design by Lyle Kayser, of the former Ballistic Research Laboratory. It is an extension of the principles developed under the high capacity artillery projectile program. James Bender, U.S. Army Research Laboratory (ARL) 75-pound shell program originator, sponsored the experiments, provided guidance, and assisted in the analysis. The ARL machine shop (specifically, Gary Sprenkle) did a masterful job in fabricating the projectiles and offering constructive suggestions. Finally, the personnel at the Transonic Experimental Facility were able to evaluate the design in a timely manner, and their efforts are appreciated.

INTENTIONALLY LEFT BLANK

---

## Contents

---

1.	Introduction .....	1
2.	Design Aspects .....	2
3.	Results and Discussion .....	9
4.	Conclusions .....	17
	References .....	19
	Distribution List .....	21
	Report Documentation Page .....	23
<b>Figures</b>		
1.	Isometric and Rear View of the 75-pound Projectile .....	1
2.	Components of the 75-pound Projectile .....	3
3.	Schematic of Fin Opening .....	4
4.	View of the Compound Angle of the Hinge Line .....	6
5.	Effective Fin Cant Angle as a Function of Fin Opening Angle .....	7
6.	Effective Fin Cant Angle as a Function of Fin Opening Angle, Zero Yaw and Zero Spin .....	8
7.	Schematic Showing Orientation of Fins A Through D Relative to Pitch Plane .....	8
8.	Schematic Showing Orientation of Experimental Setup .....	10
9.	Seventy-five-pound Projectile at 16.77 m From the Muzzle .....	10
10.	Fin Opening Motion Over a 120-foot Trajectory .....	11
11.	Fin Opening Angle as a Function of Time, Zero Yaw, 15.6-Hz Spin Rate .....	12
12.	Fin Opening Angle as a Function of Time, 5 Degrees of Yaw, 15.6-Hz Spin Rate .....	12
13.	Fin Opening Angle as a Function of Time, 5 Degrees of Yaw, 30-Hz Spin Rate .....	14
14.	Fin Opening Angle as a Function of Time, No Locking Mechanism, Zero Yaw, 15.6-Hz Spin Rate .....	15
15.	Fin Opening Angle as a Function of Time, No Locking Mechanism, 5 Degrees of Yaw, 15.6-Hz Spin Rate .....	16
16.	Fin Angle Response to Impact With Fin Stop as a Function of Time for No Locking Mechanism, 5 Degrees of Yaw, 15.6-Hz Spin Rate ..	16
<b>Table</b>		
1.	Hinge and Boat Tail Angles .....	7

INTENTIONALLY LEFT BLANK

# EXPERIMENTAL VALIDATION OF ELLIPTICAL FIN-OPENING BEHAVIOR

---

## 1. Introduction

---

Proposals to create a composite artillery projectile have arisen recently. A prime benefit of such a round would be a roughly 25% reduction in projectile weight. The weight reduction has significant benefits in terms of transportation and loading/handling of the projectiles. A proposed composite artillery projectile offered by the U.S. Army Research Laboratory employs fins as a stabilization method. Spin stabilization (the present standard for artillery projectiles) would require extensive engineering and specialized fabrication to withstand the torque loads applied in bore. Additionally, the mass distribution for efficient spin stabilization in a lightweight projectile would be unfavorable for use with the current projectile payloads.

An alternative to conventional fins (fixed, folding, or wrap around) is offered with the use of elliptical, deployable fins. These fins (dubbed "Kayser" fins in honor of their creator, Lyle Kayser), combined with their inherent boat tail, reduce the increase in drag associated with the addition of fins to a previously un-finned body. The typical Kayser four-fin configuration is shown in Figure 1. The fins are stowed in bore and are designed to fully deploy to 135 degrees (2.36 radians) upon muzzle exit.

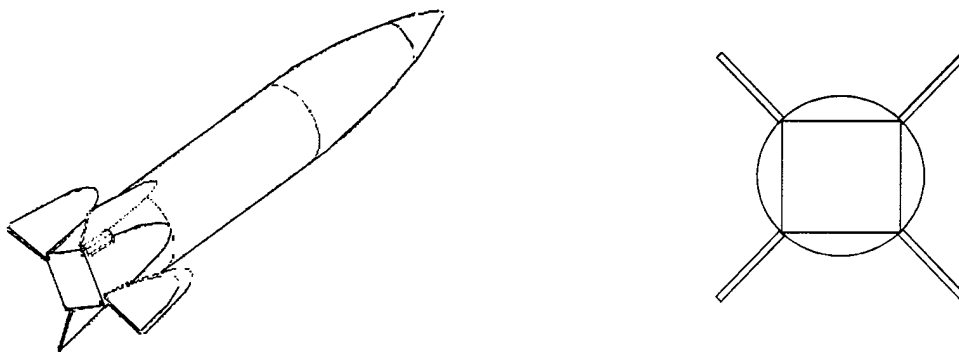

Figure 1. Isometric and Rear View of the 75-pound Projectile.

When stowed, the fins are folded against the boat tail, and this configuration allows more efficient use of the boat tail volume. For example, the boat tail

volume may now be configured to house a rocket motor similar to that of the M549. Typically stowed, folding fins intrude into the body/boat tail and clearly would not allow such an option. The deployment properties of Kayser fins have been the described previously [1]. These previous descriptions have relied on controlled static experiments since the fin design has only recently been ballistically evaluated. The fin opening behavior is primarily governed by controllable factors such as fin mass properties, fin cant angles, and projectile spin. Less controllable factors such as yaw states at muzzle exit also affect the fin deployment. The effect of yaw is generally to inhibit the deployment of fins on the wind side and to enhance deployment on the lee side. This report offers insight about the effect of aerodynamic loads encountered at launch on fin opening via the use of the experimental data coupled with the solution of equations given in previous analytical models.

---

## 2. Design Aspects

---

Fin-stabilized artillery projectiles with fixed fin designs would be very inefficient. They would require large sabot volumes and would mandate large cannons. Deployable fins are clearly necessary for artillery shells if they are going to retain their same basic geometry and be fired from existing 155-mm cannons. For the Kayser fin configuration, the fin area and boat tail design are integrated so that they provide an adequate fin area for stabilization as well as a boat tail that reduces base drag in addition to being deployable. A 7° boat tail angle was selected on the basis of a previous Ballistic Research Laboratory report, which indicated that it was nearly optimal from an aerodynamic drag standpoint [2]. This boat tail in the aforementioned report was axisymmetrical, but it offers confirmation to some extent that this same angle is suitable for the Kayser fin boat tail. This angle provides sufficient fin area to stabilize the projectile. Another criterion to be met is the deployment performance of the fin once it exits the gun.

Figure 2 shows the components of a projectile for ballistic experimentation. This complemented the modeling efforts.

Knowledge of the range of motion for the fin is critical if the fin is expected to sweep through a 2.36-radian (135°) angle and lock into position. Fortunately, there is some latitude in the design parameters of the fin since stability requirements do not impose a unique design. The appropriate amount of over-design to mitigate random launch conditions and assure consistent fin deployment is not well determined. Random launch conditions such as muzzle exit yaw and pitch angles affect the aerodynamic force,  $F_{aero}$ , on the fins. An estimate of this behavior is obtained from actual firings and is offered here.

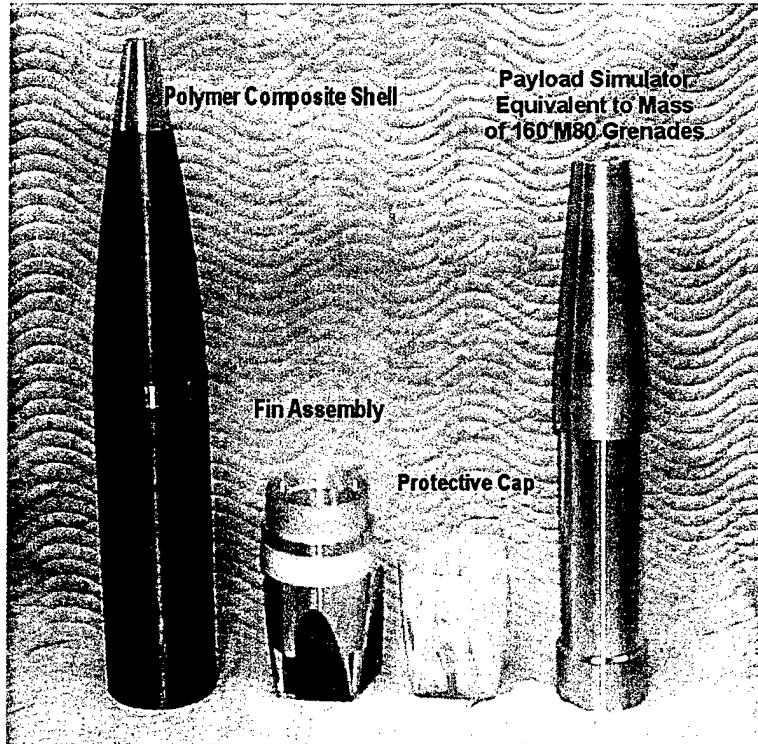

Figure 2. Components of a 75-pound Projectile.

In a previous effort, Kayser and Brown developed a simplified model of the fin opening event [1]. Their analysis resulted in the following equation of motion for the fin blade:

$$\ddot{\theta} + \frac{0.8b\omega^2}{a} \sin\theta = \frac{0.8F_{aero}}{ma} \quad (1)$$

with

a	Fin half-height
b	Distance from the projectile axis to the fin pivot point
m	Fin mass
$F_{aero}$	Aerodynamic force attributable to fin cant angle (tends to close the fully opened fin)
$\theta$	Angle between projectile body and fin face
$\omega$	Projectile rotational rate

This ordinary differential equation (1) describes the fin opening angle,  $\theta$ , in terms of the geometric, mass and aerodynamic properties of the fin illustrated in Figure 3. The equation is a close analog to the equation of a pendulum (2) with the exception that the equation of motion for the fin opening includes a forcing

function on the right-hand side. The forcing function is produced by the applied (aerodynamic) forces acting on the fin blade:

$$\ddot{\theta} + \frac{g}{l} \sin \theta = 0. \quad (2)$$

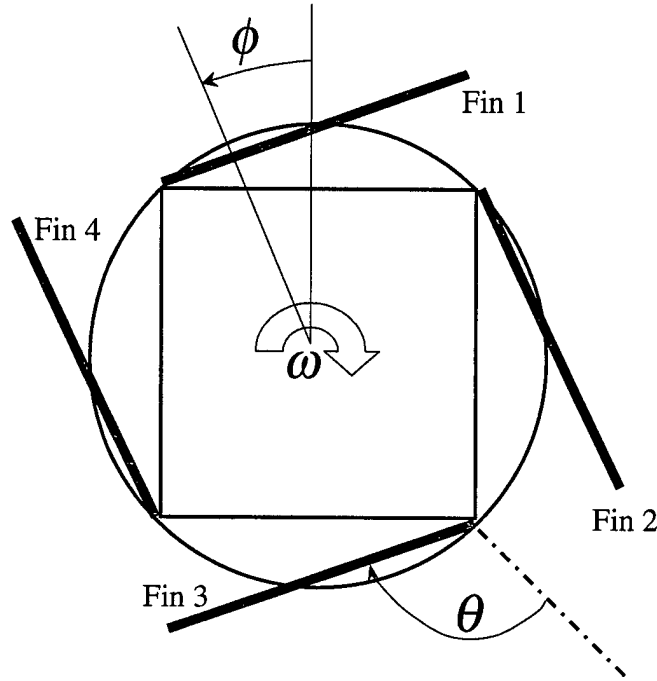

Figure 3. Schematic of Fin Opening.

The aerodynamic forces acting on the fin blade during the fin opening event can be complicated because of the three-dimensional flow field produced by the interaction of the fins and the projectile body during launch and flight. To make the problem manageable, Kayser and Brown made the following assumptions: (1) the aerodynamic force acting on the fin blade was proportional to the local cant angle of the fin relative to the free stream flow, and (2) the aerodynamic force was related to the roll-producing moment produced by the fin cant. Kayser and Brown related the aerodynamic force in the following manner:

$$F_{aero} = \frac{F_{max}}{\delta_f} \delta_r \quad (3)$$

in which  $\delta_r$  is the instantaneous effective cant angle of the fin blade and  $F_{max}$  is the aerodynamic lift force produced by the fin when it is fully deployed to the final cant angle  $\delta_f$ .

Kayser and Brown found that for their fin geometry, the effective fin cant angle could be approximated by a simple cosine function. In the current effort, a formal derivation of the fin cant angle in terms of two hinge angles, the projectile boat tail angle, the free stream angle of attack, and the fin opening angle is presented. From this analysis, it is found that the approximated form of the fin cant angle used by Kayser and Brown is not universally valid. Furthermore, by the inclusion of two angles to describe the hinge line for the fin blade, additional control of the aerodynamic properties of the fin (including the fin cant angle when the fin is fully open) is possible. In addition, free stream angle of attack appears to significantly affect the fin opening event.

The local fin cant angle is defined as the enclosed angle between the free stream velocity vector and the vector normal to the fin surface and is related as follows:

$$|\vec{U}| \sin \delta_r = \vec{U} \cdot \vec{n} \quad (4)$$

To compute the fin cant angle, both the fin normal vector  $\vec{n}$  and the fin stream velocity vector  $\vec{U}$  must be determined.

The fin normal vector is purely a function of the geometric properties of the fin. The current derivation assumes that the boat tail and fins are cut symmetrically. The hinge line for the fin blade is described by two compound angles shown in Figure 4. Note also that the first compound angle for the hinge is not required to have the same angle as the projectile boat tail. This allows for additional control of the fin aerodynamic to enhance the fin opening. The fin normal vector has the following form:

$$\begin{aligned} \vec{n} = & \tilde{i} (\cos\gamma_1 \cos\gamma'_2 \cos\gamma_4 \sin\gamma_5 + \cos\gamma_1 \sin\gamma'_2 \cos(3\pi/4 - \theta) \sin\gamma_4 \sin\gamma_5 \\ & + \sin\gamma_1 \sin(3\pi/4 - \theta) \sin\gamma_4 \sin\gamma_5 - \cos\gamma_1 \sin\gamma'_2 \sin(3\pi/4 - \theta) \cos\gamma_5 \\ & + \sin\gamma_1 \cos(3\pi/4 - \theta) \cos\gamma_5) \\ & + \tilde{j} (-\sin\gamma'_2 \cos\gamma_4 \sin\gamma_5 + \cos\gamma'_2 \cos(3\pi/4 - \theta) \sin\gamma_4 \sin\gamma_5 - \cos\gamma'_2 \sin(3\pi/4 - \theta) \sin\gamma_5) \\ & + \tilde{k} (\sin\gamma_1 \cos\gamma'_2 \cos\gamma_4 \sin\gamma_5 - \sin\gamma_1 \sin\gamma'_2 \cos(3\pi/4 - \theta) \sin\gamma_4 \sin\gamma_5 \\ & + \cos\gamma_1 \sin(3\pi/4 - \theta) \sin\gamma_4 \sin\gamma_5 - \sin\gamma_1 \sin\gamma'_2 \sin(3\pi/4 - \theta) \cos\gamma_5 \\ & + \cos\gamma_1 \cos(3\pi/4 - \theta) \cos\gamma_5) \end{aligned} \quad (5)$$

$$\tan\gamma'_2 = \cos\gamma_1 \tan\gamma_2$$

$$\gamma_4 = \gamma'_2$$

$$\gamma_5 = \gamma_{BT} - \gamma_1$$

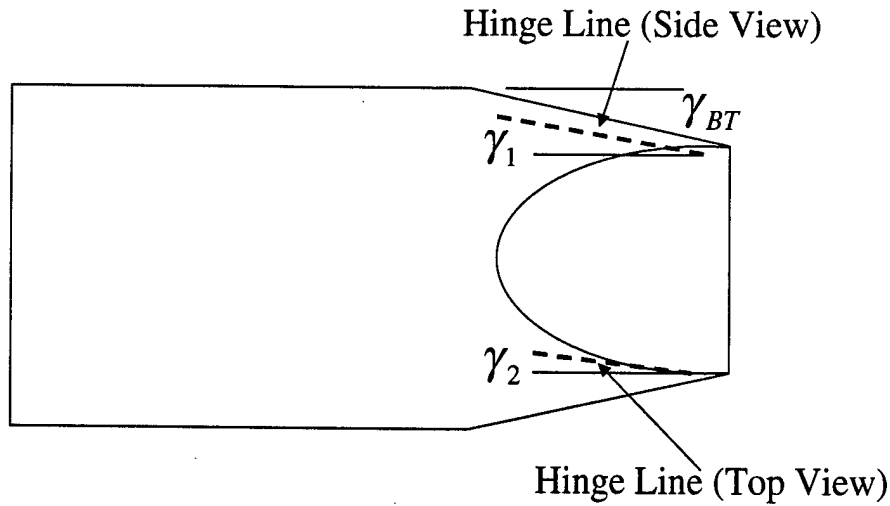

Figure 4. View of the Compound Angle of the Hinge Line.

The free stream velocity vector has the following form:

$$\bar{U} = U_{\infty} \{ \tilde{i} (\cos \alpha) + \tilde{j} (\sin \alpha \sin \phi) + \tilde{k} (\sin \alpha \cos \phi) \} \quad (6)$$

in which  $U_{\infty}$  is the magnitude of the free stream velocity,  $\alpha$  is the angle of attack, and  $\phi$  is the orientation angle of the pitch plane (shown in Figure 3).

Figure 5 shows the fin cant angle as a function of the fin opening angle for the conceptual design of Kayser and Brown versus the design recently fired for zero pitch and yaw angles. Geometric parameters for each design are shown in Table 1. (Kayser and Brown provide limited details of the geometric configuration of their design, particularly the hinge line. The details of this design used in the current analysis have been reconstructed from some of the results published originally by Kayser and Brown.) Also shown is the simple cosine approximation form of the fin cant angle proposed by Kayser and Brown. Clearly, the effective cant angle for the current design would be poorly approximated by the simple cosine function. The variation in free stream angle induced by the fin angular velocity is not included in Figure 5 because its effect is minimal (less than a degree) and varies over the fin span.

Figure 5 also shows that early in the opening event, the fin cant angle is negative, which results in an aerodynamic force that tends to open the fin. At larger fin opening angles, the fin cant angle changes sign and the aerodynamic force resists the fin opening. Compared to the design of Kayser and Brown, the present fin geometry investigated has a negative cant angle for a greater range of fin opening angles. However, the final fully deployed cant angle is significantly smaller.

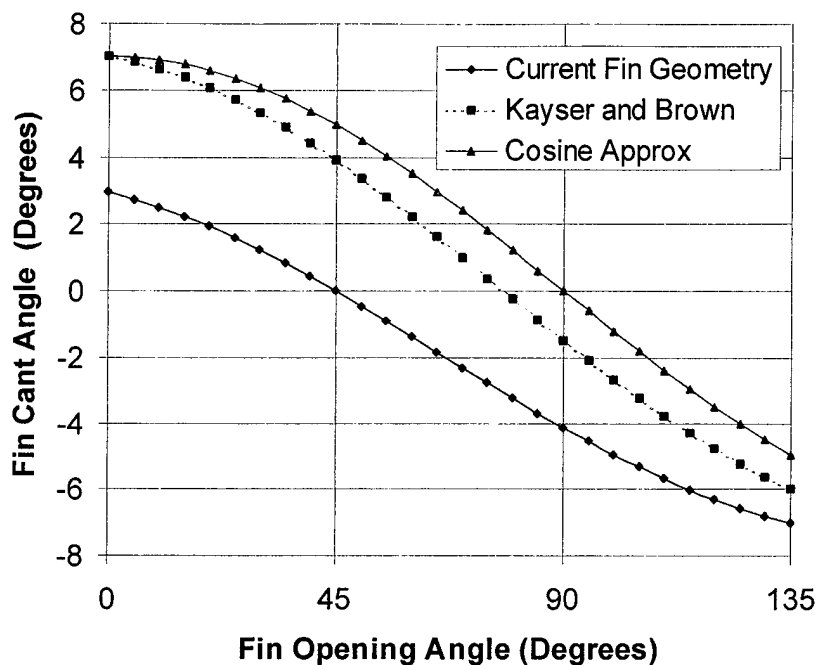

Figure 5. Effective Fin Cant Angle as a Function of Fin Opening Angle.

Table 1. Hinge and Boat Tail Angles

	Current Design	Kayser and Brown
$\gamma_1$ (degrees)	5.	6.
$\gamma_2$ (degrees)	2.	4.
$\gamma_{BT1}$ (degrees)	7.	6.

In the current analysis, the effect of projectile yaw is included in the effective cant angle. Figure 6 shows the effective cant angle as a function of fin opening angle for 5 degrees of yaw. For reference, the effective cant angle for zero yaw is also shown. Since the effect of yaw depends on the orientation of the pitch plane relative to the fins, four different fin orientations relative to the pitch plane are shown. These four orientations are shown schematically in Figure 7. Fins A and C are located on the lee and wind sides of the body, respectively. As noted previously, a negative cant angle results in an aerodynamic force that tends to open the fin. In the fully closed position, the effective cant angle of Fin A (lee side) is essentially the sum of the boat tail angle and the yaw angles ( $7^\circ + 5^\circ = 12^\circ$ ), while the effective cant angle of Fin C (wind side) is the difference between the boat tail angle and the yaw angles ( $7^\circ - 5^\circ = 2^\circ$ ). Fins B and D have

the same cant angle as for the zero yaw case when fully closed. Although the fin cant angle produces a favorable aerodynamic force on the lee side when the fin is in the closed position, the fin cant angle is positive when the fin is fully deployed. Fin D has a positive fin cant angle through nearly the last 90 degrees of the fin opening angle, while Fin B has a negative fin cant angle for all fin opening angles. It is interesting to note that the average cant angle for all four fins is equal to the zero yaw cant angle for all fin opening angles.

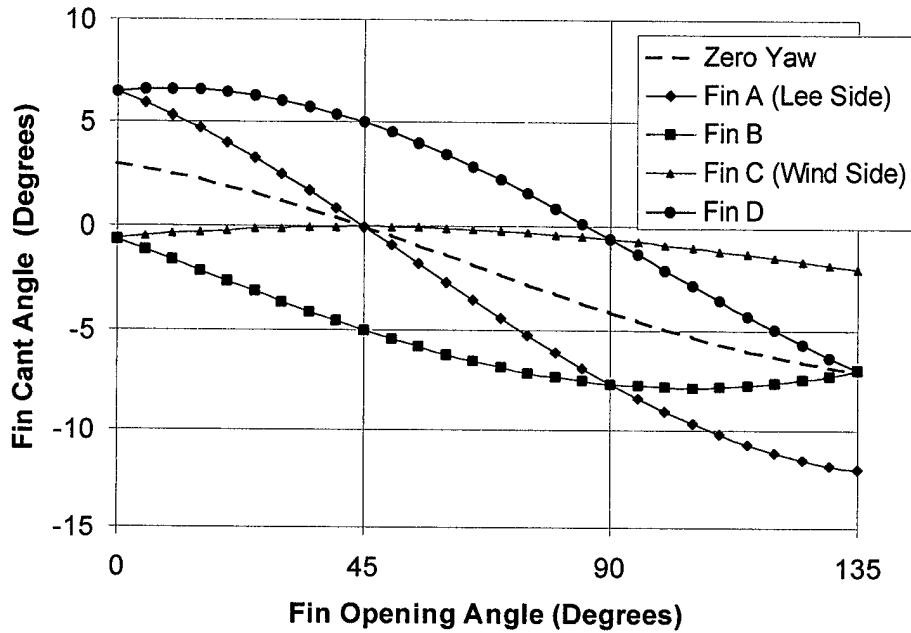

Figure 6. Effective Fin Cant Angle as a Function of Fin Opening Angle, Zero Yaw and Zero Spin.

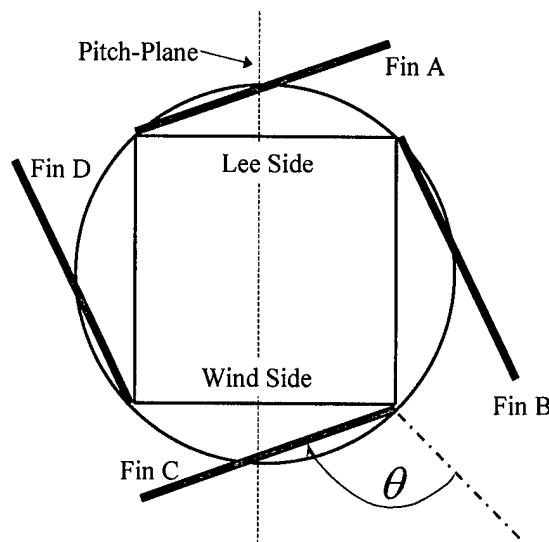

Figure 7. Schematic Showing Orientation of Fins A Through D Relative to Pitch Plane.

The fin blades for the Kayser design typically do not have a symmetrical cross section since part of the exposed surface (when the fins are fully closed) is cut to conform to the cylindrical geometry of the projectile. This results in a leading edge bevel on the fin that produces an aerodynamic force that opposes the opening of the fin. This aerodynamic effect is also included in the present aerodynamic model. With this addition to the model, the aerodynamic force can be written in the following form:

$$F_{aero} = F_{\delta} \delta_r + F_{bevel} \quad (7)$$

The leading edge bevel is effectively oriented at the boat tail angle of the projectile. Using the wedge pressure from compressible flow theory and computing the bevel area, we can determine the aerodynamic force attributable to the bevel.

The fin force attributable to fin cant  $F_{\delta}$  was determined by a simple two-dimensional compressible flow theory for the lift of a flat plate.

$$F_{\delta} = \frac{8\rho_{\infty} V_{\infty}^2 A_{fin}}{\sqrt{M_{\infty}^2 - 1}} \quad (8)$$

This approach yields values of the fin force that are similar to those used by Kayser and Brown in their analysis. In the current configuration,  $F_{\delta} = 9985 \text{ N/rad}$  and  $F_{bevel} = 193 \text{ N}$ .

---

### 3. Results and Discussion

---

Two 75-pound composite projectiles with Kayser fins were fabricated and fired at the Transonic Experimental Facility of Aberdeen Proving Ground. These projectiles used an aluminum boat tail portion coupled with a composite body and ogive. They also carried a payload that matched the payload mass of the M483. The purpose of these firings was twofold. The first was to verify that the composite body was structurally sound for M119A2 (zone 7Red) charge loads and their corresponding accelerations. The second purpose was to assure that the fins would deploy and the round would fly as expected over the short trajectory of the range. The projectile firings used the following instrumentation: two cameras, a high speed digital camera, and a yaw card, as well as pressure gauges and wide angle video coverage. A Weibel radar was used to monitor the velocity. The zone 7R charge produced a muzzle velocity of 740 m/s for the 75-pound shell. The projectiles were fired from an M199 cannon. A sketch of the experimental setup is shown in Figure 8.

The firings produced mixed results. The composite bodies demonstrated structural integrity. The fin opening behavior produced less satisfactory results. When the film and yaw card data were reviewed, it appeared that only one of the four fins deployed and locked.

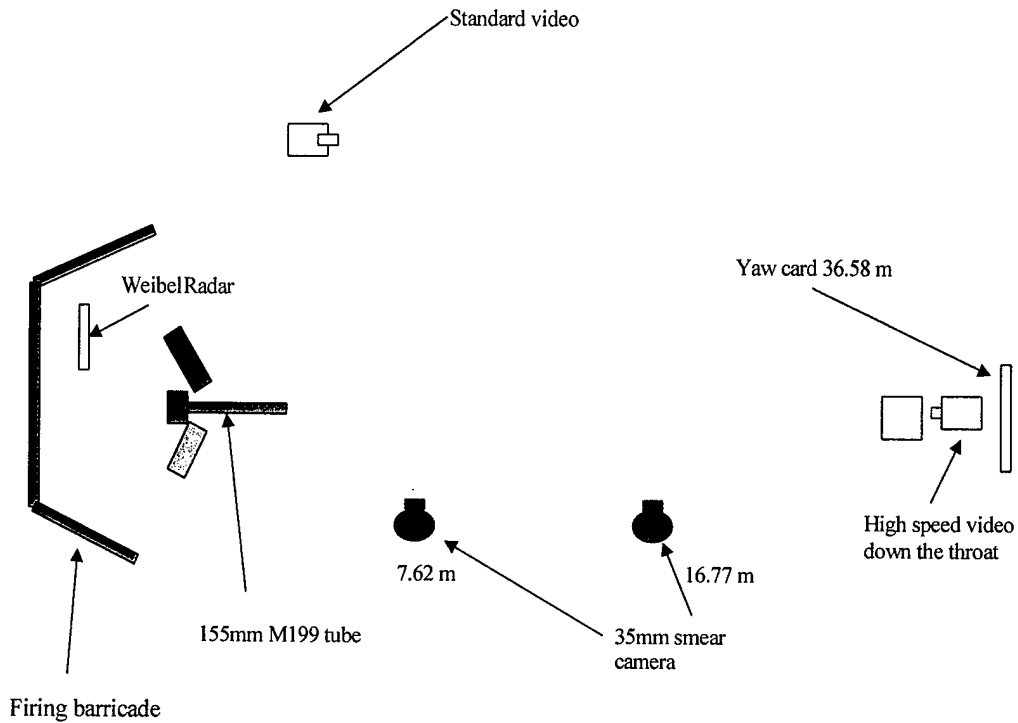

Figure 8. Schematic Showing Orientation of Experimental Setup.

Figure 9 is a smear photograph at 16.77 m and shows what appear to be two fins almost fully open. The fins look undamaged, although their angular position is difficult to determine simply from a normal view. The measured yaw angle is approximately 5 degrees.

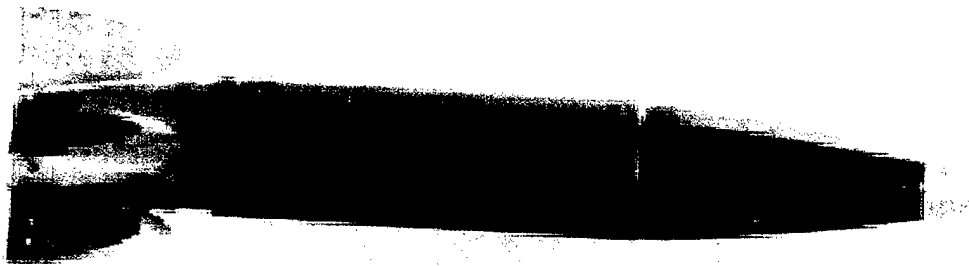

Figure 9. Seventy-five-pound Projectile at 16.77 m From the Muzzle.

The video looking down the gun tube offers the best information about fin behavior. Frames taken from the video and shown in Figure 10 illustrate the oscillation of the fin. There are no trajectory location markers to which to relate the images. The upper left frame shows the projectile nearest the muzzle, and the lower right shows the fin state nearest the camera (roughly 120 feet from the muzzle). The frames lack sufficient resolution to make accurate angular measurements of the fins' angles relative to the projectile body.

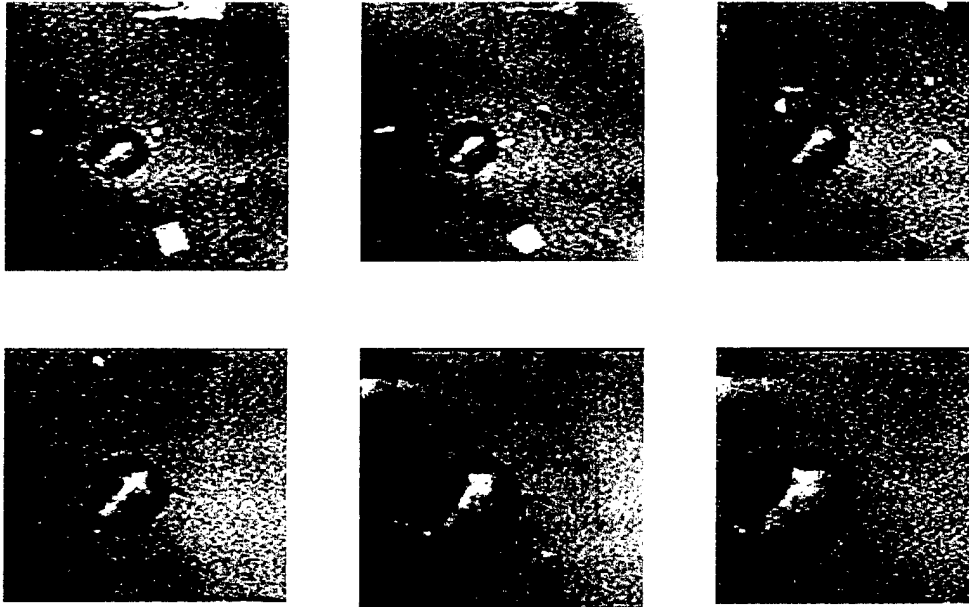

Figure 10. Fin Opening Motion Over a 120-foot Trajectory.

The fin opening model, developed from the previous equations, was used to interpret the firings. Figure 11 shows the results from the application of this model for a projectile spin rate of 15.6 Hz and zero yaw. For the conditions examined here, the model predicts that the fin blades open to their fully deployed position within 10 ms. This corresponds to about 7.5 m of flight or 60 degrees of rotation of the projectile. The fin opening angle is given as the angular difference between the fully deployed position and the instantaneous angle of the fin (as shown in Figure 2).

A review of the smear photographs shows that the projectile was noticeably yawed shortly after launch. The model was applied to determine whether the effect of yaw retarded the fins from opening. The analysis assumes constant yaw amplitude over the period of interest (about 40 ms), but the projectile rotates relative to the pitch plane at 15.6 Hz (the measured spin rate). Figure 12 shows the results of the analysis for a yaw angle of 5 degrees. Initially, Fin 1 is located on the lee side of the body and Fin 3 is located on the wind side of the body. Fins 2 and 4 are oriented initially 90 degrees from the pitch plane so that Fin 2

will be located on the wind side of the body and Fin 4 will be located on the lee side of the body after the projectile initiates 90 degrees of roll because of its spin rate, as seen in Figure 3.

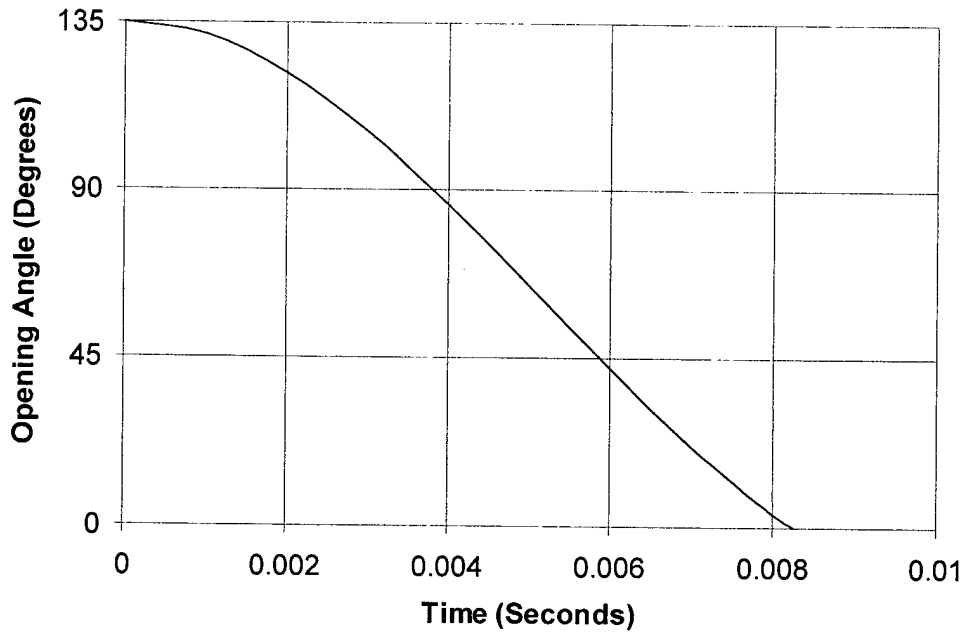

Figure 11. Fin Opening Angle as a Function of Time, Zero Yaw, 15.6-Hz Spin Rate.

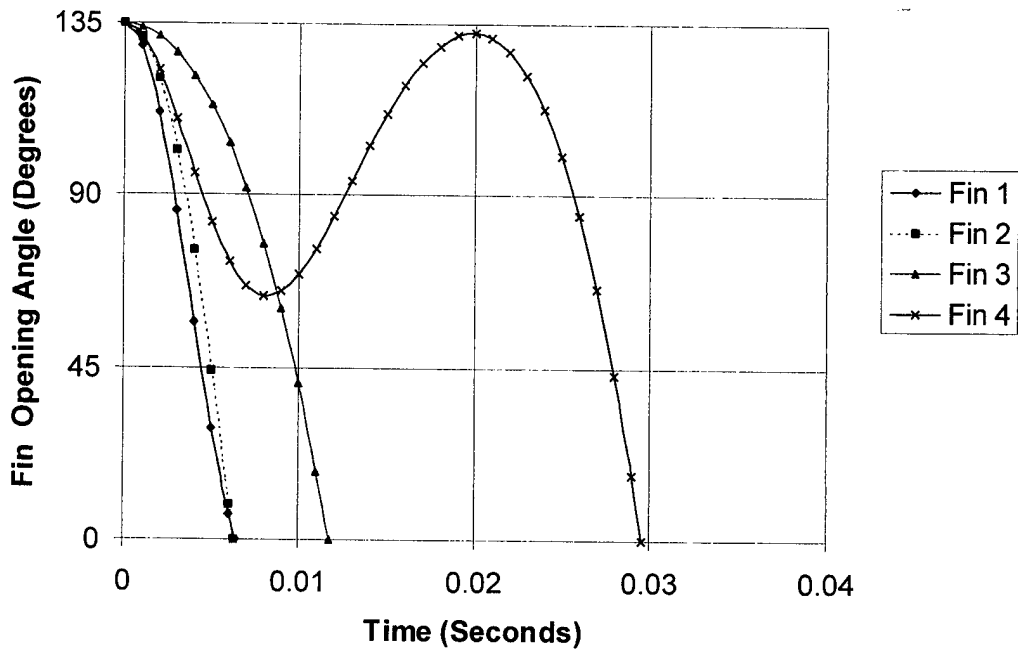

Figure 12. Fin Opening Angle as a Function of Time, 5 Degrees of Yaw, 15.6-Hz Spin Rate.

The model results indicate that Fins 1 and 2 deploy rapidly and Fin 3 is slightly delayed. The opening of Fin 4 is significantly longer than the other three fins. Only as Fin 4 rotates through the lee plane does the fin fully deploy. Despite the slow opening of Fin 4, the model shows that all the fins fully deploy after the body spins through a half rotation. These results demonstrate that the free stream angle of attack is an important factor when one is considering fin deployment.

The presence of yaw can either accelerate or retard the opening of the fin blades. In this case, Fins 1 and 2 open more quickly because of the presence of yaw, since the effective cant angle of the fin is increased by the yaw. For Fin 1, which is initially located on the lee side of the body, the initial cant angle of the fin is nearly 12 degrees, since the yaw adds an additional 5 degrees to the existing cant angle of the fin. However, for Fin 3, the initial effective cant angle of the fin is reduced to only 2 degrees because of the yaw. Fin 4 shows the most significant effect of yaw. In this case, the yaw initially has no effect on the effective fin cant angle since the fin blade is aligned with the pitch plane when it is fully closed. As the fin begins to open because of the centrifugal force, the effective fin cant angle quickly becomes positive and the fin opening is retarded. Complete opening of Fin 4 is not possible until the projectile rotates 90 degrees and Fin 4 is on the lee side of the body.

The deployment of the fins is also accelerated when the projectile spin rate increases. Figure 13 shows the fin opening angle as a function of time for a projectile spin rate of 30 Hz. For this increased spin rate, the fin opening angle shows a monotonic decrease in the fin opening angle until the fin is fully deployed. The effect of increasing the spin rate is twofold. First, the larger spin rate increases the centrifugal force that accelerates the fin opening. A secondary effect of the increased spin rate is that the fins are rotating more quickly with respect to the pitch plane. Fins 3 and 4, whose deployment is delayed because of the yaw, rotate more quickly into a position where the aerodynamic forces attributable to the yaw have a more beneficial effect. Although the actual time for deployment of Fin 4 is decreased for a spin rate of 30 Hz, it still takes approximately one-third of a rotation to deploy the fin as compared to nearly half of a rotation for a spin rate of 15.6 Hz.

The level of difficulty in increasing the projectile spin rate is uncertain. The melting temperature and the frictional coefficient between the slip band obturator and the polyethylene band seat were taken into account in the choice of the obturator material and geometry. Changes such as removing the polyethylene band seat and increasing the projectile surface roughness in the obturator slot should increase the starting torque and the resultant spin, but these solutions are unproven and they bear research and validation.

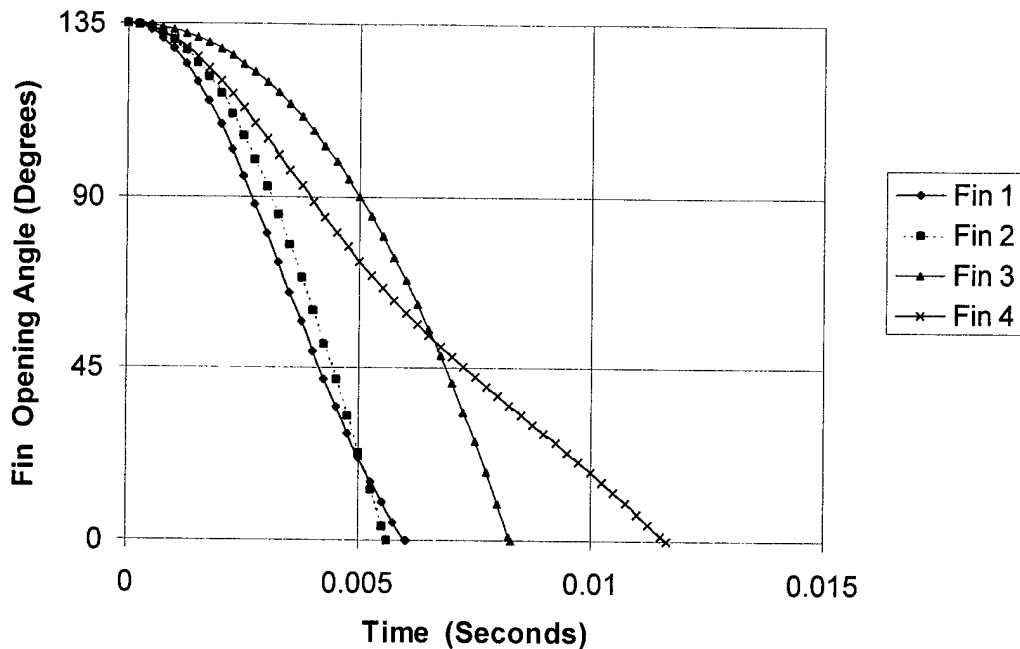

Figure 13. Fin Opening Angle as a Function of Time, 5 degrees of Yaw, 30-Hz Spin Rate.

One explanation for the failure of the fins to fully deploy and lock is that the fin detent pins were not adequate to lock or lock securely enough to hold the fins fully open. This explanation does not account for the fact that the images of the fin larger opening angles ( $> 1.9$  radians) were not detected in a film review. A review of the down-bore photographs should show opening angles greater than 1.9 radians for most of the fins over the course of the trajectory monitored. The non-locking or non-securing detent pin explanation is somewhat consistent with the fin motions that were observed. Three of the four fins can be seen closing from semi-open position. Of course, one fin for each firing was verified to have deployed and locked at  $135^\circ$ . Whether the three semi-open fins ever reached the fully open state remains unanswered. The round had not completed a full revolution along its trajectory by the last camera location, and not all the fins had been exposed to the lee flow. This flow is conducive to fin opening.

Though the analysis shows the retarded opening of one of the fins, the analysis does not appear to fully corroborate the fin behavior observed in the video. The fin opening model with yaw was applied to examine the behavior of the fins if no locking mechanism had been present. Two conditions for the fin were considered that represented extremes: 1) The fin has a perfectly elastic collision with the fin stop, or 2) the fin collision is totally inelastic and the fin comes to a complete slow stop (while not locking) at the fin stop. Figure 14 shows the two oscillatory behaviors. It is difficult to imagine that the fin would stop and the

locking pins would not engage (situation 2), but it is possible that these pins were damaged by the high pressure chamber environment.

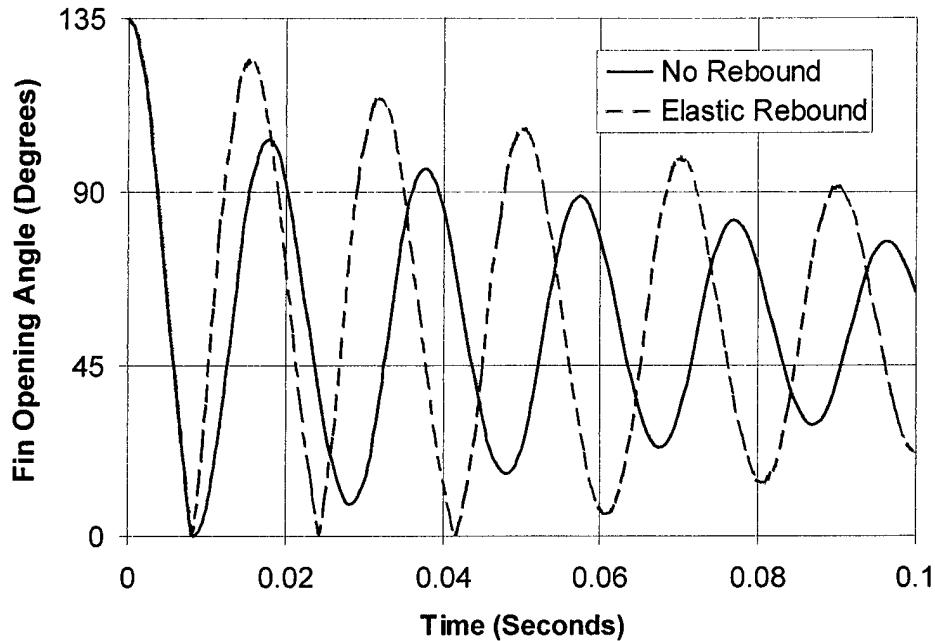

Figure 14. Fin Opening Angle as a Function of Time, No Locking Mechanism, Zero Yaw, 15.6-Hz Spin Rate.

As mentioned previously, the video indicated that the projectile was yawed during the fin opening event. Figure 15 shows the response of each of the four fins in the presence of 5 degrees of yaw when no locking mechanism is present. Early in the event, before the fin reached the fully opened position, the fin motion is identical to the locking case (see Figure 6). After reaching the fully opened position, the fins oscillate between the fully open and partially opened positions. After approximately one projectile body rotation, the motion becomes periodic and a phase shift is predicted for the fin motions. In contrast to the zero yaw case, the presence of yaw enhances the fins' opportunity to reach their fully open and locked position once during each rotation of the projectile.

The results in Figure 15 were obtained by assuming an inelastic rebound of the fin against the stop. When an elastic rebound is considered, the motion of the fin is somewhat more complicated than the inelastic rebound. Figure 16 shows the motion of Fin 2 for both elastic and inelastic rebound. Although the oscillations of the fin are larger for the elastic rebound case, the general behavior of the fin is similar for both cases. In particular, the fin will only reach the fully deployed position when the fin is close to the lee side. For the inelastic rebound case, the fin reaches the fully deployed position only once during each rotation of the

projectile. For the elastic rebound case, there are two to three instances when the fin reaches the fully deployed position for each rotation of the projectile.

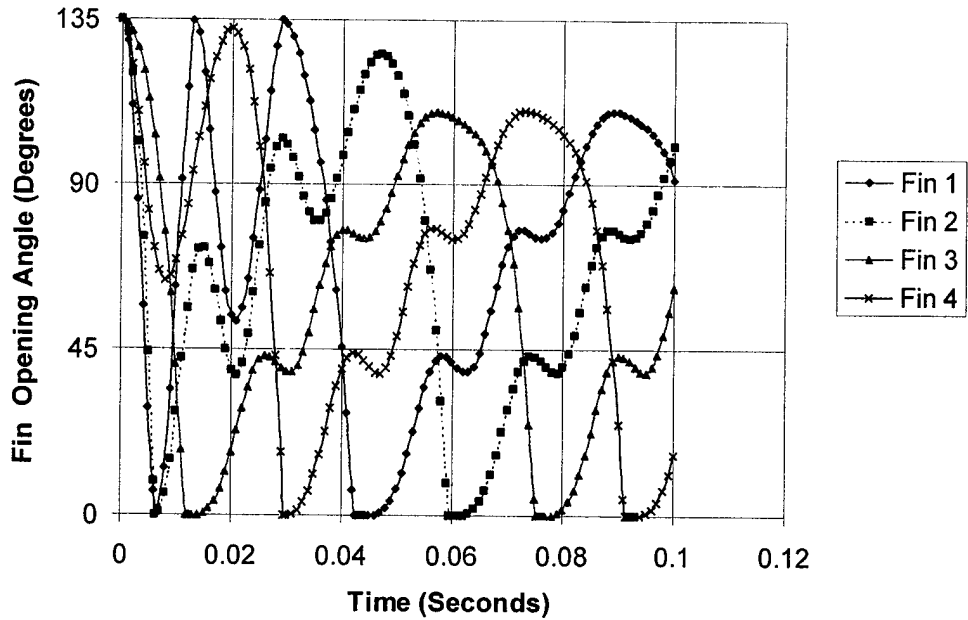

Figure 15. Fin Opening Angle as a Function of Time, No Locking Mechanism, 5 Degrees of Yaw, 15.6-Hz Spin Rate.

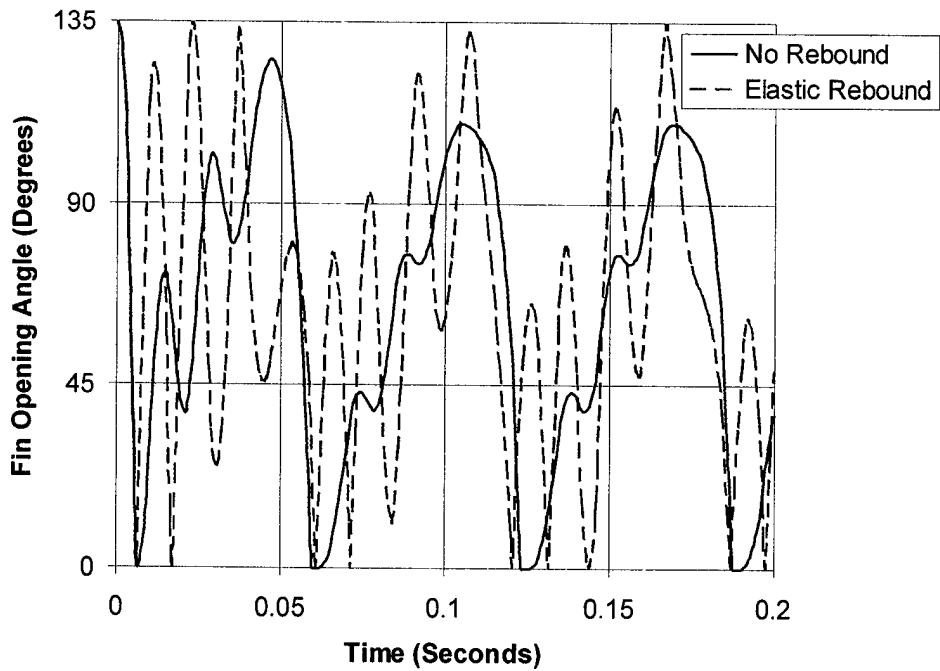

Figure 16. Fin Angle Response to Impact With Fin Stop as a Function of Time for No Locking Mechanism, 5 Degrees of Yaw, 15.6-Hz Spin Rate.

---

## 4. Conclusions

---

The analysis of the fin opening event has been used to provide some interpretation of the results of the experimental firings. In the absence of yaw, the analysis indicates that the fins should open and lock soon after launch. The presence of yaw can slightly delay the opening of individual fins. However, as the projectile rotates relative to the pitch plane, the effect of yaw will eventually provide sufficient aerodynamic force to cause all the fins to fully deploy within a projectile rotation. Since the observed motion from the video of the experiment indicates that the fins open but do not lock, it appears that the locking mechanism either failed or did not engage for at least some of the fins. Oscillations of the fins between the fully deployed and partially open positions are possible when the fins do not lock.

Based on the modeling results as well as review of the range film and engineering judgment, some modifications have been incorporated for future firings. Locking pins with an increased spring tension have been selected and are scheduled for use. Additionally, a higher projectile spin rate, perhaps near 30 Hz, is also planned. An increased firing elevation has also been suggested to ensure that each of the fins will have an increased opportunity to rotate through the lee flow environment, which is conducive to fin opening.

INTENTIONALLY LEFT BLANK

---

## References

---

1. Kayser, L., and T. Brown, "Fin Motion After Projectile Exit From Gun Tube," BRL-TR-3375, U.S. Army Ballistics Research Laboratory, Aberdeen Proving Ground, MD, July 1992.
2. Dickinson, E., "The Effect of Boattailing on the Drag Coefficient of Cone Cylinder Projectiles at Supersonic Velocities," Memorandum Report 842, Ballistic Research Laboratory, Aberdeen Proving Ground, MD, November 1954.

INTENTIONALLY LEFT BLANK

NO. OF  
COPIES ORGANIZATION

1 ADMINISTRATOR  
DEFENSE TECHNICAL INFO CTR  
ATTN DTIC OCA  
8725 JOHN J KINGMAN RD STE 0944  
FT BELVOIR VA 22060-6218

1 DIRECTOR  
US ARMY RSCH LABORATORY  
ATTN AMSRL CI AI R REC MGMT  
2800 POWDER MILL RD  
ADELPHI MD 20783-1197

1 DIRECTOR  
US ARMY RSCH LABORATORY  
ATTN AMSRL CI LL TECH LIB  
2800 POWDER MILL RD  
ADELPHI MD 20783-1197

1 DIRECTOR  
US ARMY RSCH LABORATORY  
ATTN AMSRL D D SMITH  
2800 POWDER MILL RD  
ADELPHI MD 20783-1197

2 COMMANDER DAHLGREN DIV  
ATTN CODE G33 J FRAYSSE  
CODE G61 M KELLY  
NAVAL SURFACE WARFARE CTR  
17320 DAHLGREN ROAD  
DAHLGREN VA 22448-5100

1 DTI ASSOCIATES  
ATTN JEFF SURKOSKY  
17119 DAHLGREN RD  
KING GEORGE VA 22485

ABERDEEN PROVING GROUND

2 DIRECTOR  
US ARMY RSCH LABORATORY  
ATTN AMSRL CI LP (TECH LIB)  
BLDG 305 APG AA

1 CDR USATECOM  
ATTN AMSTE TE F L TELETSKI  
RYAN BLDG

1 COMMANDER  
US ARMY ABERDEEN TEST CTR  
ATTN STEC LI  
BLDG 400

NO. OF  
COPIES ORGANIZATION

1 COMMANDER  
US ARMY TACOM ARDEC  
ATTN AMSTA AR FSF T J MATTS  
BLDG 120

1 DIR US AMSAA  
ATTN AMXSY CA  
BLDG 392

1 DIRECTOR  
US ARMY RSCH LABORATORY  
ATTN AMSRL WM B A HORST  
BLDG 4600

1 DIRECTOR  
US ARMY RSCH LABORATORY  
ATTN AMSRL WM BA T G BROWN  
BLDG 4600

9 DIRECTOR  
US ARMY RSCH LABORATORY  
ATTN AMSRL WM BC B GUIDOS  
D LYON J NEWILL  
J GARNER (2CYS)  
P WEINACHT (2 CYS)  
V OSKAY A ZIELINSKI  
BLDG 390

3 DIRECTOR  
US ARMY RSCH LABORATORY  
ATTN AMSRL WM MB J BENDER  
R KASTE (2 CYS)  
BLDG 4600

INTENTIONALLY LEFT BLANK

# REPORT DOCUMENTATION PAGE

*Form Approved*  
OMB No. 0704-0188

Public reporting burden for this collection of information is estimated to average 1 hour per response, including the time for reviewing instructions, searching existing data sources, gathering and maintaining the data needed, and completing and reviewing the collection of information. Send comments regarding this burden estimate or any other aspect of this collection of information, including suggestions for reducing this burden, to Washington Headquarters Services, Directorate for Information Operations and Reports, 1215 Jefferson Davis Highway, Suite 1204, Arlington, VA 22202-4302, and to the Office of Management and Budget, Paperwork Reduction Project (0704-0188), Washington, DC 20503.

1. AGENCY USE ONLY (Leave blank)		2. REPORT DATE September 2001	3. REPORT TYPE AND DATES COVERED Final	
4. TITLE AND SUBTITLE Experimental Validation of Elliptical Fin Opening Behavior			5. FUNDING NUMBERS PR: AH80	
6. AUTHOR(S) Garner, J.M.; Weinacht, P.; Kaste, R.P. (all of ARL)				
7. PERFORMING ORGANIZATION NAME(S) AND ADDRESS(ES) U.S. Army Research Laboratory Weapons & Materials Research Directorate Aberdeen Proving Ground, MD 21005-5066			8. PERFORMING ORGANIZATION REPORT NUMBER	
9. SPONSORING/MONITORING AGENCY NAME(S) AND ADDRESS(ES) U.S. Army Research Laboratory Weapons & Materials Research Directorate Aberdeen Proving Ground, MD 21005-5066			10. SPONSORING/MONITORING AGENCY REPORT NUMBER ARL-TR-2527	
11. SUPPLEMENTARY NOTES				
12a. DISTRIBUTION/AVAILABILITY STATEMENT Approved for public release; distribution is unlimited.			12b. DISTRIBUTION CODE	
13. ABSTRACT (Maximum 200 words)  An effort to improve the performance of ordnance has led to the consideration of the use of folding elliptical fins for projectile stabilization. A second order differential equation was used to model elliptical fin deployment history and accounts for deployment with respect to the geometric properties of the fin, the variation in fin aerodynamics during deployment, the initial yaw effect on fin opening, and the variation in deployment speed based on changes in projectile spin. This model supports tests conducted at the Transonic Experimental Facility, Aberdeen Proving Ground, Maryland, which examined the opening behavior of these uniquely shaped fins. A companion boat tail configuration is created by sectioning the projectile base and joining with the fin. The configuration is both space efficient and aerodynamic. Reduced drag coefficients have been documented for this configuration and it is employable on a variety of projectiles. The fins use the centrifugal force from the projectile spin to deploy. During the deployment, the fin aerodynamic forces vary with angle-of-attack changes in the free stream. Model results indicate that projectile spin dominates the initial opening rates and that aerodynamics dominate near the fully open state. Vibratory fin motions after elastic and inelastic collisions with the fin stop are also examined. The aerodynamics and initial state conditions correspond to a zone 7w artillery firing (roughly Mach 2.25) that uses a slip band obturator and with muzzle exit yaws of 0 and 5 degrees. The model results are examined to explain the observed behavior and to suggest improvements for later designs.				
14. SUBJECT TERMS elliptical fin fin opening			15. NUMBER OF PAGES 30	
			16. PRICE CODE	
17. SECURITY CLASSIFICATION OF REPORT Unclassified	18. SECURITY CLASSIFICATION OF THIS PAGE Unclassified	19. SECURITY CLASSIFICATION OF ABSTRACT Unclassified	20. LIMITATION OF ABSTRACT	