

*ER Fletcher*

POR-6742

(WT-6742)

**MIDDLE NORTH SERIES  
DIAL PACK AND PRAIRIE FLAT EVENTS**

**PROJECT OFFICERS REPORT**

PROJECTS LN-109 AND LN-116

**BLAST VALVE TESTS**

**HEADQUARTERS**

**DEFENSE NUCLEAR AGENCY**

**WASHINGTON, D.C. 20305**

Reproduced From  
Best Available Copy

Issuance date: 8 December 1972

20011024 092

APPROVED FOR PUBLIC RELEASE  
DISTRIBUTION UNLIMITED

Destroy this report when it is no longer needed.  
Do not return to sender.

POR-6742  
(WT-6742)

MIDDLE NORTH SERIES

DIAL PACK AND PRAIRIE FLAT EVENTS

PROJECT OFFICERS REPORT--PROJECTS LN-109 AND LN-116

BLAST VALVE TESTS

HEADQUARTERS  
DEFENSE NUCLEAR AGENCY  
WASHINGTON, D.C. 20305

George Nevrincean, Project Officer

Eugene F. Witt

Bell Telephone Laboratories Inc.  
Whippany, New Jersey 07981

APPROVED FOR PUBLIC RELEASE

DISTRIBUTION UNLIMITED

THIS PAGE IS INTENTIONALLY LEFT BLANK.

## ABSTRACT

A modified section of an underground communication building was constructed at the Defence Research Establishment, Suffield, and experiments were conducted to determine blast-valve performance, overpressures in the air shaft and downstream plenums, and overpressure damage to air ducts. The air ducts were installed in order to give an indication of the expected damage to air-conditioning equipment which would be caused by overpressure pulses. The experiments were conducted in the PRAIRIE FLAT and DIAL PACK Events. Both experiments employed 500 tons of TNT to produce the blast effects. In the PRAIRIE FLAT Event, the test structure was engulfed by a peak free-field blast overpressure of 34 psi. Two louver blast valves were mounted in the structure. One was closed directly by the blast forces and suffered no damage. That was not the case for the air ducts located in the downstream plenum. The other blast valve was properly controlled to close before blast arrival. In the DIAL PACK Event, the test structure was engulfed by a 12-psi blast overpressure. A louver blast valve and a lighter weight blast shutter were both blast closed. Air ducts behind the louver valve were only slightly indented, and those behind the blast shutter were undamaged.

THIS PAGE IS INTENTIONALLY LEFT BLANK.

## TABLE OF CONTENTS

<u>Chapter</u>		<u>Page</u>
	Abstract - - - - -	iii
1	Introduction - - - - -	1
	1.1. PRAIRIE FLAT objectives - - - - -	1
	1.2. DIAL PACK objectives - - - - -	5
	1.3. Background - - - - -	5
	1.3.1 Need for data - - - - -	5
	1.3.2 Blast valves and controls - - - - -	8
	1.3.3 Importance of test results - - - - -	13
	1.3.4 Previous and related work - - - - -	17
	1.4. Prediction models - - - - -	18
	1.4.1 Plenum pressures - - - - -	18
	1.4.2 Duct indentation - - - - -	23
2	Procedure - - - - -	26
	2.1. Test structure - - - - -	26
	2.2. Instrumentation - - - - -	27
	2.2.1 Location and types - - - - -	27
	2.2.2 Calibration - - - - -	27
	2.2.3 Transducer mounting - - - - -	27
	2.2.4 Recording package - - - - -	27
	2.3. Equipment for test - - - - -	33
	2.3.1 Blast valves and controls - - - - -	33
	2.3.2 Sheet metal ducts - - - - -	35
	2.4. Final field operations - - - - -	37
3	Results and discussion - - - - -	38
	3.1. Free-field overpressures - - - - -	38
	3.2. Air-shaft overpressures - - - - -	38
	3.2.1 PRAIRIE FLAT results - - - - -	38
	3.2.2 DIAL PACK results - - - - -	42
	3.2.3 Comparison with shock-tube results - - - - -	44
	3.3. Valve performance - - - - -	44
	3.3.1 Louver valve - - - - -	44
	3.3.2 Blast shutter - - - - -	52
	3.4. Plenum pressures - - - - -	52
	3.4.1 Wave forms - - - - -	55
	3.4.2 Predictions - - - - -	55
	3.5. Duct deformation and damage - - - - -	62
	3.6. Other data - - - - -	65

TABLE OF CONTENTS (Continued)

<u>Chapter</u>	<u>Page</u>
4	
Conclusions and recommendations -----	68
4.1. Air-shaft overpressures -----	68
4.2. Valve performance -----	68
4.2.1 Louver valve subjected to maximum pressure -	68
4.2.2 Louver valve for free-field overpressure of	
12 psi -----	71
4.2.3 Blast shutter -----	71
4.3. Plenum pressures -----	71
4.4. Blast protection afforded by the blast valves -----	71
4.4.1 Buildings designed to withstand a free-field	
overpressure of 50 psi -----	71
4.4.2 Stations designed to withstand a free-field	
overpressure of 10 psi -----	72
References -----	73
 <u>Appendix</u>	
Indentation of air ducts by pressure pulses -----	75
A.1. Static deformation of duct walls -----	75
A.2. Natural frequency of duct walls -----	76
A.3. Dynamic response of duct walls to short duration	
pulses -----	76
A.4. Experimental determination of duct indentation -----	79
A.5. Volume change and pressure rise resulting from	
duct indentation -----	79
A.6. Combined effects of internal pressure and dynamic	
response of duct walls -----	80
Distribution list -----	85

## LIST OF ILLUSTRATIONS

<u>Figure</u>		<u>Page</u>
1.1	Louver blast valve -----	2
1.1	(Continued) -----	3
1.2	Test structure -----	4
1.3	Blast shutter -----	6
1.3	(Continued) -----	7
1.4	Louver operation -----	9
1.5	Blast valve control units -----	11
1.6	Blast valve control schematic -----	12
1.7	Pressure switch components -----	14
1.8	Pressure switch support -----	15
1.9	Interior details of pressure switch support -----	16
1.10	Shock-tube test of blast shutter (Chester, New Jersey Laboratories) -----	19
1.11	Schematic of 1/30-scale air shaft -----	20
1.12	One-dimensional pressure pulse in plenum downstream of air shaft -----	21
1.13	Two-dimensional shock propagation into plenum -----	22
1.14	Elastic-plastic plate deformation -----	24
2.1	Transducer locations -----	28
2.2	Pressure-gage mount and testing fixture -----	30
2.3	Accelerometer on mount -----	31
2.4	Recording package. -----	32
2.5	Installed louver blast valve as viewed from air shaft, PRAIRIE FLAT Event -----	34
2.6	Duct construction and test locations -----	36
3.1	Free-field overpressures as measured at location P1 -----	39
3.2	Air-shaft overpressures, PRAIRIE FLAT Event -----	40
3.3	Shock patterns in air shaft, constructed from PRAIRIE FLAT Event results -----	41
3.4	Air-shaft overpressures, DIAL PACK Event -----	43
3.5	Comparison of shock-tube data and the PRAIRIE FLAT Event data -----	45
3.6	Comparison of shock-tube data and the DIAL PACK Event data -----	46
3.7	Valve position versus time data for the PRAIRIE FLAT Event -----	47
3.8	Valve closing times, DIAL PACK Event -----	49
3.9	Rib strains in louver valve and air-shaft overpressures at valve locations, PRAIRIE FLAT Event -----	50
3.10	Comparison of peak rib strains in louver valves -----	51
3.11	Blast shutter viewed from plenum chamber, postshot, DIAL PACK Event -----	54

LIST OF ILLUSTRATIONS (Continued)

<u>Figure</u>	<u>Page</u>
3.12 Plenum overpressures -----	56
3.13 Simplified shock-wave diagram for upper plenum, PRAIRIE FLAT Event -----	57
3.14 Simplified shock-wave diagram for upper plenum, DIAL PACK Event -----	58
3.15 Simplified shock-wave diagram for lower plenum, DIAL PACK Event -----	60
3.16 Comparison of measured- and calculated-incident overpressures in plenums -----	61
3.17 Duct damage in PRAIRIE FLAT and DIAL PACK Events ----	63
3.18 Duct deformation as a function of external overpressure ----	64
3.19 Accelerations near valves, PRAIRIE FLAT Event -----	66
3.20 Soil pressures on air-shaft wall, PRAIRIE FLAT Event ----	67
4.1 Overpressure and closing time comparisons -----	70
A.1 Elastic-plastic duct wall deformation, considering internal pressure buildup -----	82

## LIST OF TABLES

<u>Table</u>		<u>Page</u>
2.1	Transducer data -----	29
3.1	Comparison of shock-tube tests and field tests on blast shutter -----	53
A.1	Pressures and deformations at yield stages -----	77
A.2	$p_e$ and $y_e$ for various gage plates -----	77
A.3	Elastic-plastic deformations of 2-foot by 6-foot duct wall ---	78
A.4	Duct deformation -----	81
A.5	Area, volume, and pressure changes -----	81

THIS PAGE IS INTENTIONALLY LEFT BLANK.

## CHAPTER 1

### INTRODUCTION

This is a combined report for two experiments, one conducted in 1968 in the PRAIRIE FLAT Event and the other conducted in 1970 in the DIAL PACK Event. The two experiments were conducted in the same test structure and employed similar test equipment.

#### 1.1. PRAIRIE FLAT OBJECTIVES.

This experiment was conducted primarily to evaluate the performance of the louver blast valve (shown in figure 1.1) in actual blast conditions. Two valves were mounted in the test structure (see figure 1.2), which simulated a portion of a full-size underground communication building. The test structure was located 560 feet from ground zero, and the expected peak free-field overpressure was 50 psi, the maximum that the louver valve was designed to withstand.

The valve, situated in the upper location in the test structure, was blast closed--a failsafe feature of the valve. Two results were determined: (1) whether or not the valve functioned properly without any mechanical damage, and (2) the overpressure levels transmitted through the valve and the damage to sheet-metal ducts placed in the plenum.

Another louver valve, situated in the lower location, was closed before blast arrival. Closure was initiated by a signal from a pressure switch located in front of the test structure, which is the normal method for closing the valves. The survival of the valve and the operation of its entire control system were checked under conditions of maximum overpressure with the valve closed.

Other data was also obtained in this experiment. Shaft overpressures were obtained in order to determine the actual pressures acting on the valves. Accelerometers were placed near the valve to measure the ground-shock-induced motions of the structure, which may affect the mechanical survival of the valve. In addition, two soil-pressure gages were placed along the outside wall of the air shaft which faced ground zero, in order to obtain some basic information on soil loading on the air-shaft wall due to air blast.

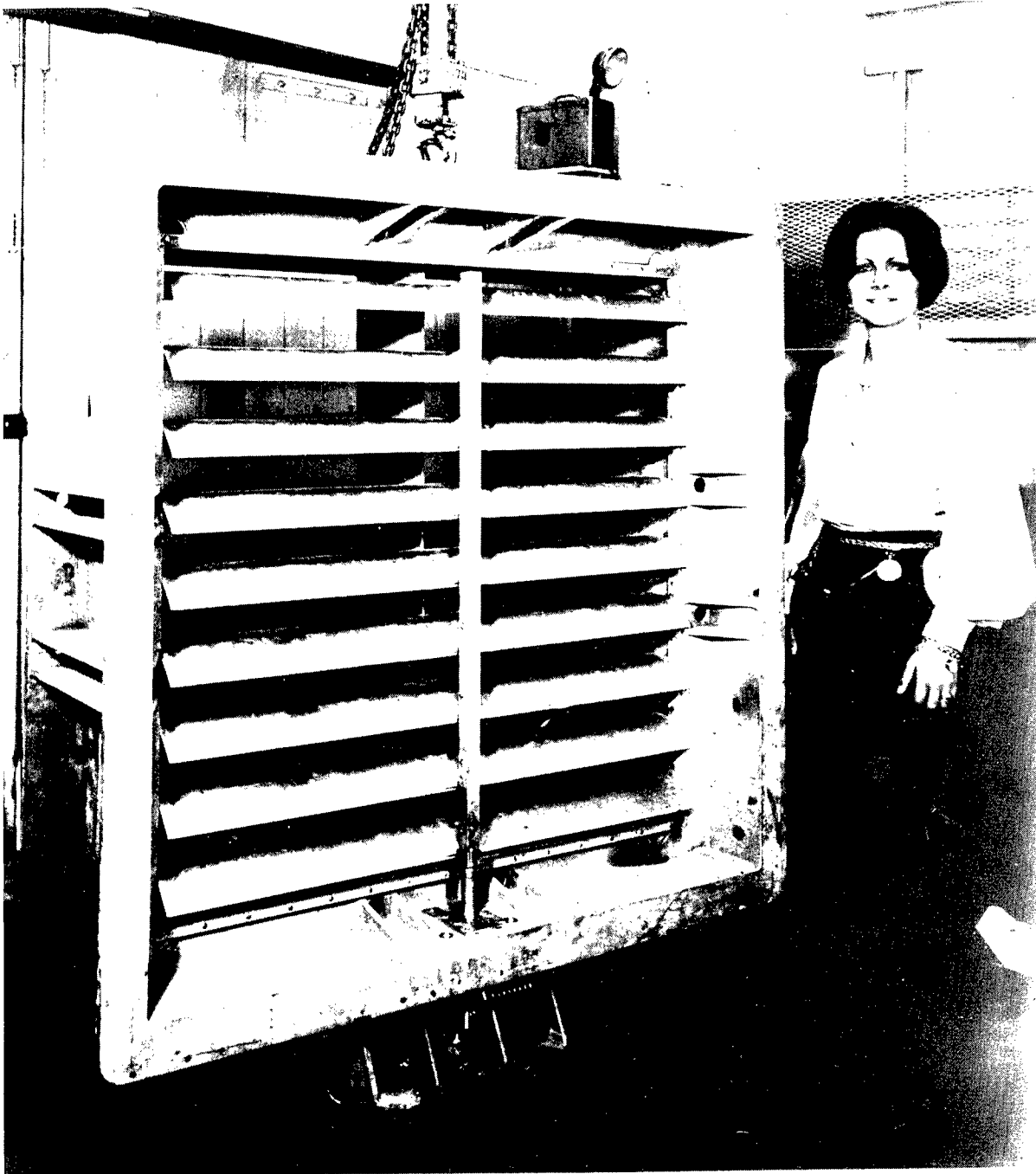

Figure 1.1. --Louver blast valve.

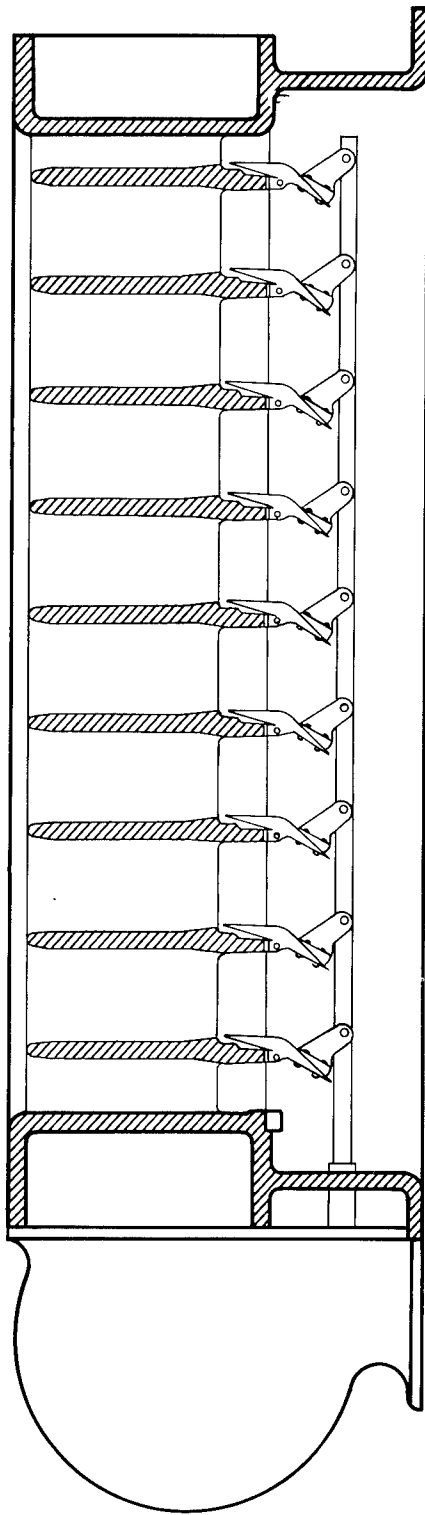

Figure 1.1. --(Continued).



Figure 1.2. --Test structure.

## 1.2. DIAL PACK OBJECTIVES.

The principal objective of the DIAL PACK experiment was to obtain the characteristics of the pressure pulses that are transmitted through blast valves which close while the blast is acting upon them.

Two different blast valves were used in this experiment in order to obtain pressure pulses of different durations. A louver valve similar to the one shown in figure 1.1 was installed in the upper location. The valve used in DIAL PACK was an earlier model which was used in a 1968 shock-tube test at the Defence Research Establishment, Suffield. (Tests on this valve are reported in reference 1.) The primary differences between the earlier and later models are in the valve actuators, but these differences did not affect the characteristics of the valves as far as blast closing was concerned. The valve used at the lower location was a blast shutter (shown in figure 1.3), a light-weight blast-closing valve for use in 2-psi buildings. It provided a shorter duration pressure pulse than did the louver valve.

The pressure pulses transmitted through these valves were measured in two ways: (1) by recording the actual pressure-time histories in the plenum, and (2) by observation of the damage that the pressure pulse did to 26-gage sheet-metal ducts which were placed in the plenums. These ducts could be considered passive instrumentation.

Other data was also obtained in the test: shaft overpressures were measured, and the performance of the valves in this blast overpressure was determined. These measurements are of particular value because the test structure in the DIAL PACK Event was located 970 feet from ground zero, and a 12-psi peak overpressure was anticipated. The results obtained in this test are directly applicable to many of the Bell System Communication Buildings, which are designed to withstand a peak free-field overpressure of 10 psi.

## 1.3. BACKGROUND.

### 1.3.1 Need for Data.

Much of the Bell System's long-distance communication network is designed to withstand some level of effects from the explosion of nuclear bombs, so that in the event of an attack upon the United States, basic communication routes would remain open for vital messages. That network requires many buildings



Figure 1.3. -- Blast shutter.

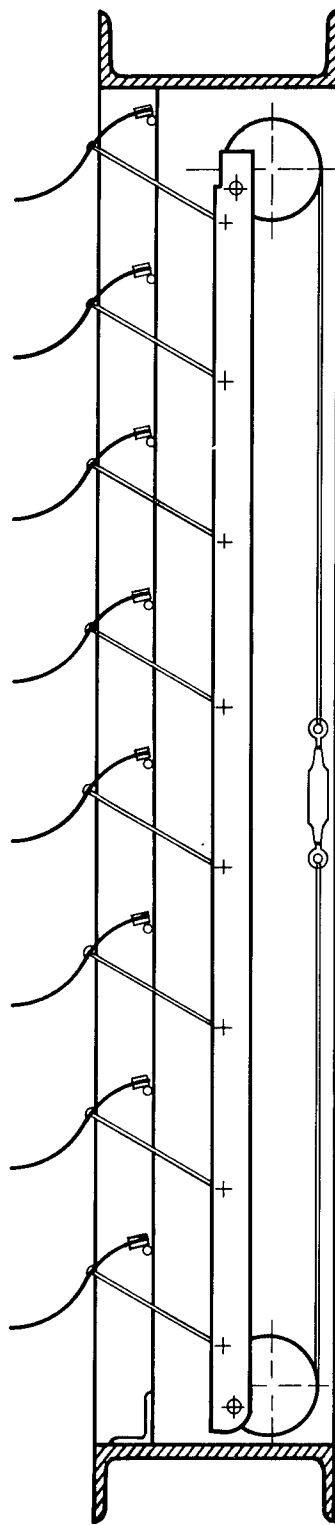

Figure 1.3. --(Continued).

for switching, power, control, and amplification; and those buildings are designed for peak free-field overpressures ranging from 2 psi to 50 psi. Many of the buildings were designed for a 10-psi peak free-field overpressure, and the DIAL PACK results were particularly applicable to those buildings.

Many of those blast-resistant buildings require blast valves on ports for ventilation, cooling, and engine-combustion air, and for engine-exhaust stacks. The engines are used to generate emergency power in the event that commercial power fails. Older buildings, generally built before 1964, had poppet valves; newer buildings have butterfly blast valves; and the newest buildings now going into service will be equipped with louver blast valves, which were tested in the 1968 PRAIRIE FLAT experiments. These three types of valves have basically similar characteristics. They are all designed to be closed on command from a sensor which detects the blast arrival. The sensors are of two types--actuated either by gamma radiation or by actual overpressure. Of course, the pressure switches must be located some distance from the station to allow sufficient time for the blast valves to close. This arrangement does not provide protection from overhead bursts. All valves are designed with a failsafe blast-closing feature, which is not considered a normal operating mode, since a potentially damaging pressure pulse could still be transmitted into the station.

### 1.3.2 Blast Valves and Controls.

The louver blast valve\* is employed in communication buildings designed to withstand a peak free-field overpressure of 50 psi or less. The valve has been designed for mounting in vertical air shafts.

The louver valve consists of a large, ribbed, aluminum casting with a square opening 44- by 44-inches. Each of the nine horizontal ribs has a center-hinged louver pinned to it. These center-hinged louvers are controlled together by the actuating rod, shown vertically in the center of the valve in figure 1.1. The valve aperture is either open or shut, depending upon the position of the louvers, as is shown in figure 1.4. The positions of the actuating rod and, of course, all the louvers are controlled by the actuator mechanism at the bottom of the valve.

---

\*A similar unit is manufactured for the Western Electric Company, under specification number KS20368.

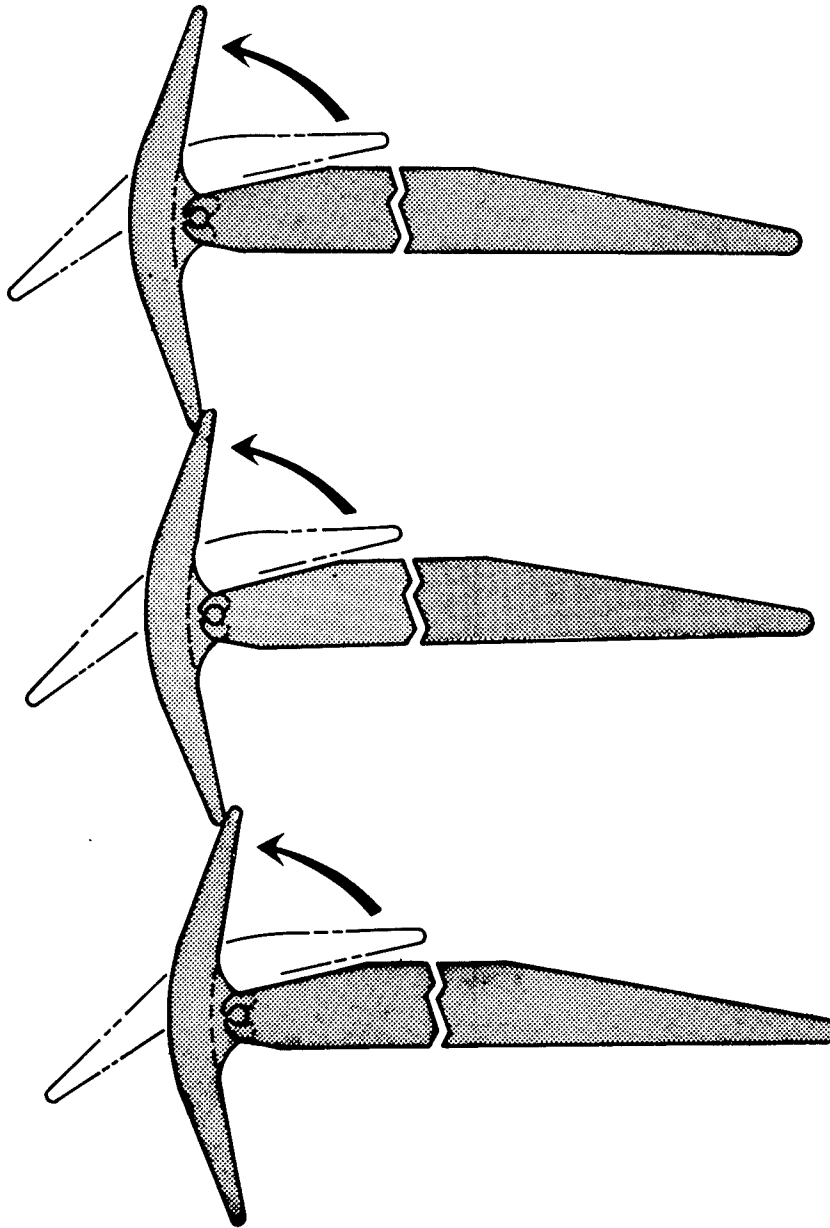

Figure 1.4. --Louver operation.

The valve is held open by a trigger mechanism positioned against a loaded spring. The trigger is held engaged by a solenoid. When the solenoid current is interrupted by the blast-valve controls, the trigger is released and the valve is slammed shut by the spring in about 50 milliseconds. Upon command, the valve is reopened by an electric motor.

The valve can also be closed directly by blast forces. When the blast wave and its resulting flow hits the louver blades, an unbalanced torque is generated and transmitted through the actuating rod into the actuator. Here a mechanical linkage is used to overpower the holding solenoid and trip the valve. Subsequently the valve closes with a combination of spring- and aerodynamically-induced forces on the blades.

The louver valve has electronic units\* which control all valve functions. The two basic units required--the detector unit and the actuator unit--were mounted in the low plenum in the PRAIRIE FLAT Event, as is shown in figure 1.5. The detector unit takes an open-circuit signal from a pressure switch or gamma sensor and converts it to a pulse, as is shown in figure 1.6. The pulse is fed in parallel to the actuator units, one for each valve.

In the PRAIRIE FLAT Event, only one valve was controlled electrically, requiring only one-half of the actuator-unit chassis, which has the components to control two separate valves.

The pulse from the detector unit is amplified in the actuator unit and is used to switch a solid-state device which cuts the current to the actuator solenoid in the blast valve. Within a few milliseconds the valve is tripped and starts to close. The actuator unit also has manual switches which can be used to command the valve to close and to reopen; and there are indicator lamps which show the position of the valve.

A pressure switch\*\* was used to initiate blast-valve closure in the PRAIRIE FLAT Event. The switch functions by providing an open circuit when engulfed by an overpressure greater than 1 psi.

---

\*Similar units are manufactured for the Western Electric Company under specification number KS20267.

\*\*A similar unit is manufactured for the Western Electric Company under specification number KS20485.

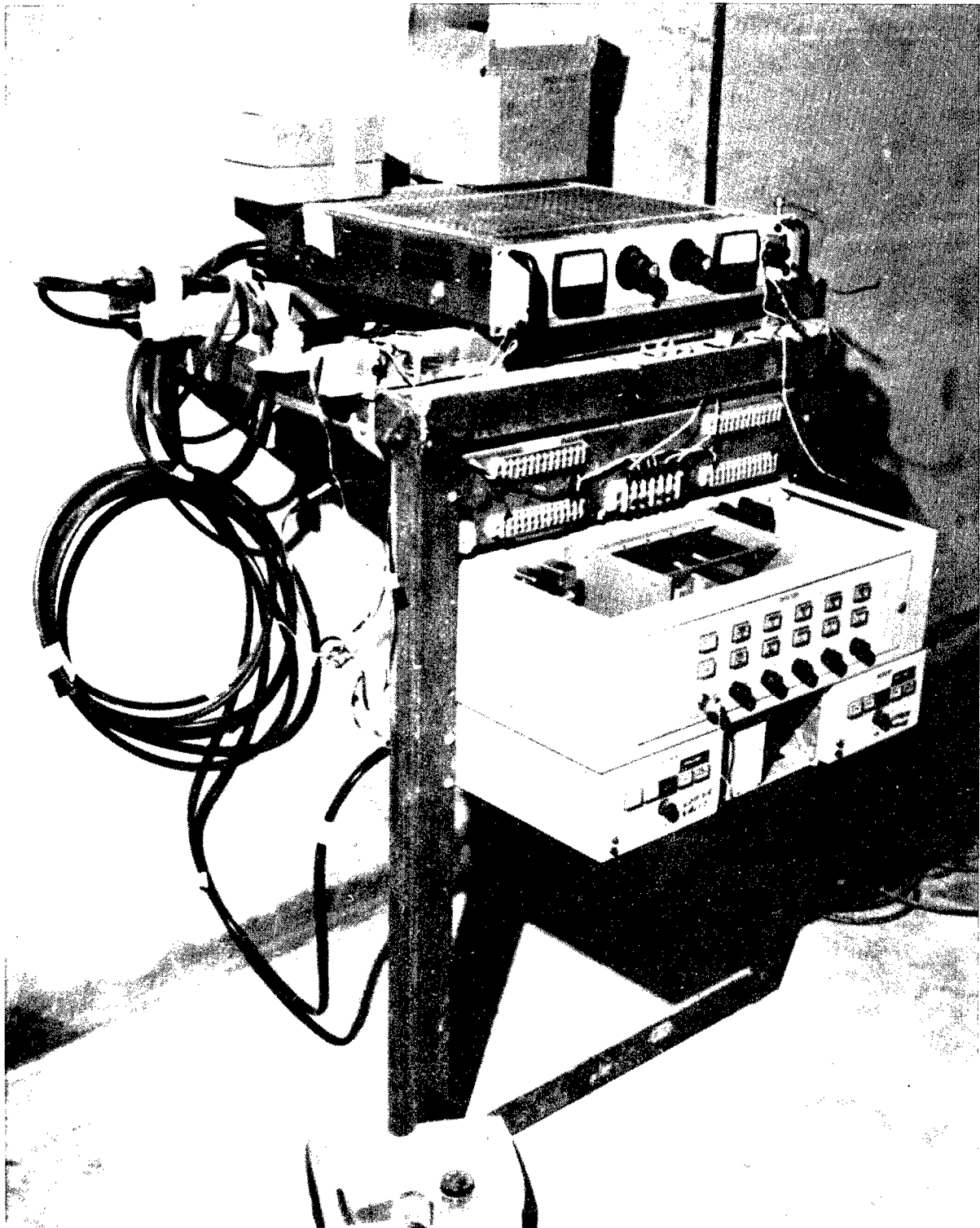

Figure 1. 5. --Blast valve control units.

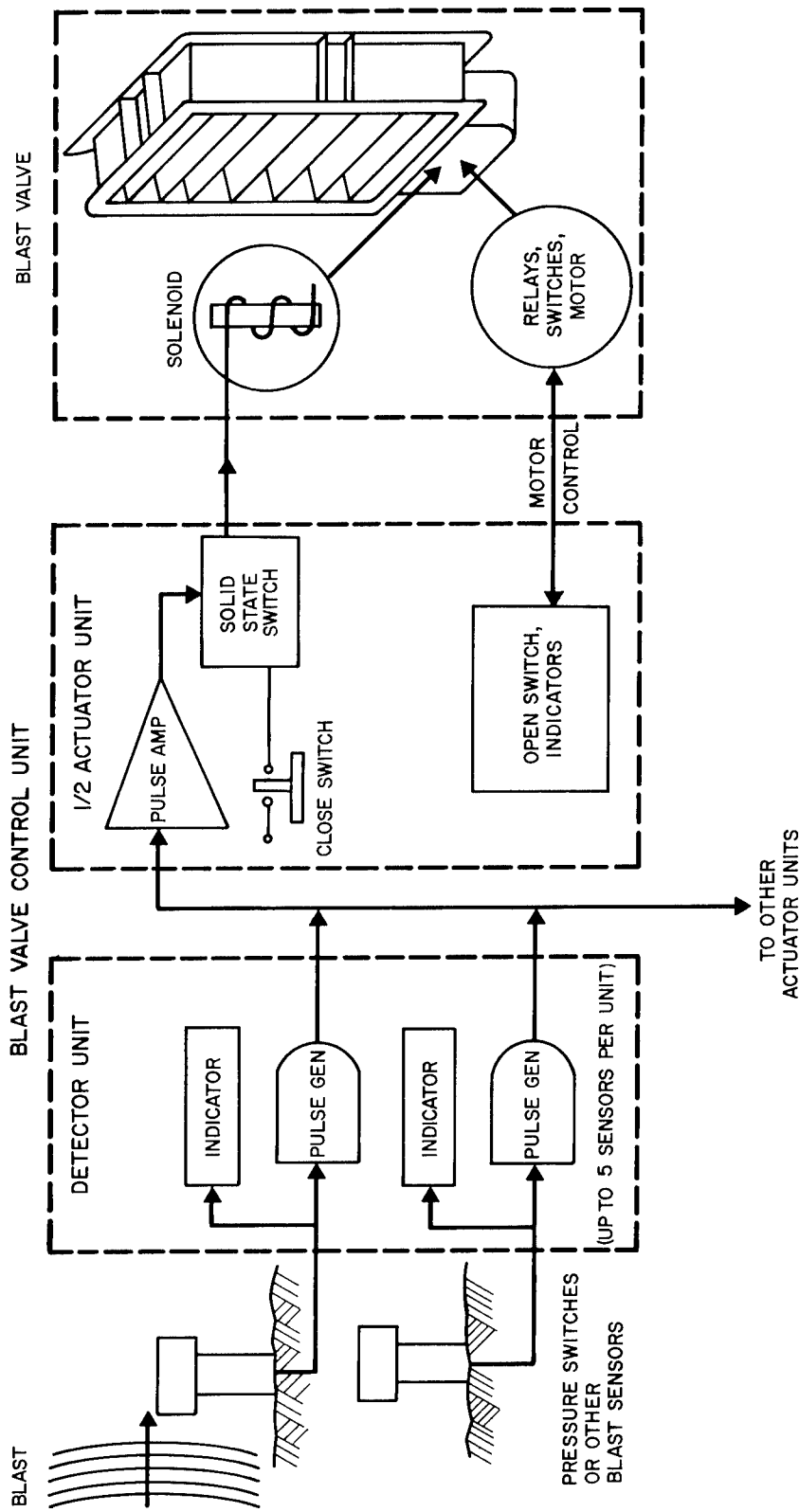

Figure 1.6. --Blast valve control schematic.

The diaphragm, shown in figure 1.7, is free to move between the cover and the backing plate. The latter protects the diaphragm from excessive deflection caused by the pressure which enters through the holes in the cover. When the diaphragm is forced against the backing plate, the actuating pin causes the contacts in the internal microswitch to open.

The pressure-switch support, shown in figures 1.8 and 1.9, allowed the blast to reach the switch, while providing protection against rain, snow, animals, insects, and exploring children.

Unlike the louver valve, the blast shutter (figure 1.3) has no controls; it is simply a blast-closing valve for use in aboveground communication buildings and is designed to withstand the effects of a peak incident free-field overpressure of 2 psi. The blast shutter used in the DIAL PACK Event was reinforced so that it could survive the higher blast pressures involved in the test.

The frame of the blast shutter is made from 6-inch 8.2-pound steel channel, forming an opening 31 inches wide and 34 inches high. Two formed steel ribs are welded across the opening to support the eight shutter blades. The blades are of 2024 ST aluminum, 0.062-inch thick, formed into an S-shape to reduce flow loss and add strength. The edges of the shutters are hinged at four locations to the frame and ribs. The hinged shutter edges were sandwiched between two 1/8-inch by 1-inch steel bars which were riveted together--this was to reinforce the valve for the higher blast pressure in DIAL PACK.

A motor control on the blast shutter had no relation to blast operation. The motor drove a set of cranks which drove two vertical bars. The shutters were linked by pins to these bars, thus enabling the motor to open or close the shutter. When open, the shutters were held in position by light coil springs on the pins. A blast loading would cause the shutters to compress the springs, slide down the pins, and slam closed. The springs would force the louver open after the decay of the blast pressure.

### 1.3.3 Importance of Test Results.

In the PRAIRIE FLAT Event, the louver valve and its controls were tested in actual blast conditions. The valve was mounted in a full-size structure, shown in figure 1.2, with an air shaft and valve openings very similar to those employed in actual underground buildings. The top and bottom valve locations were chosen

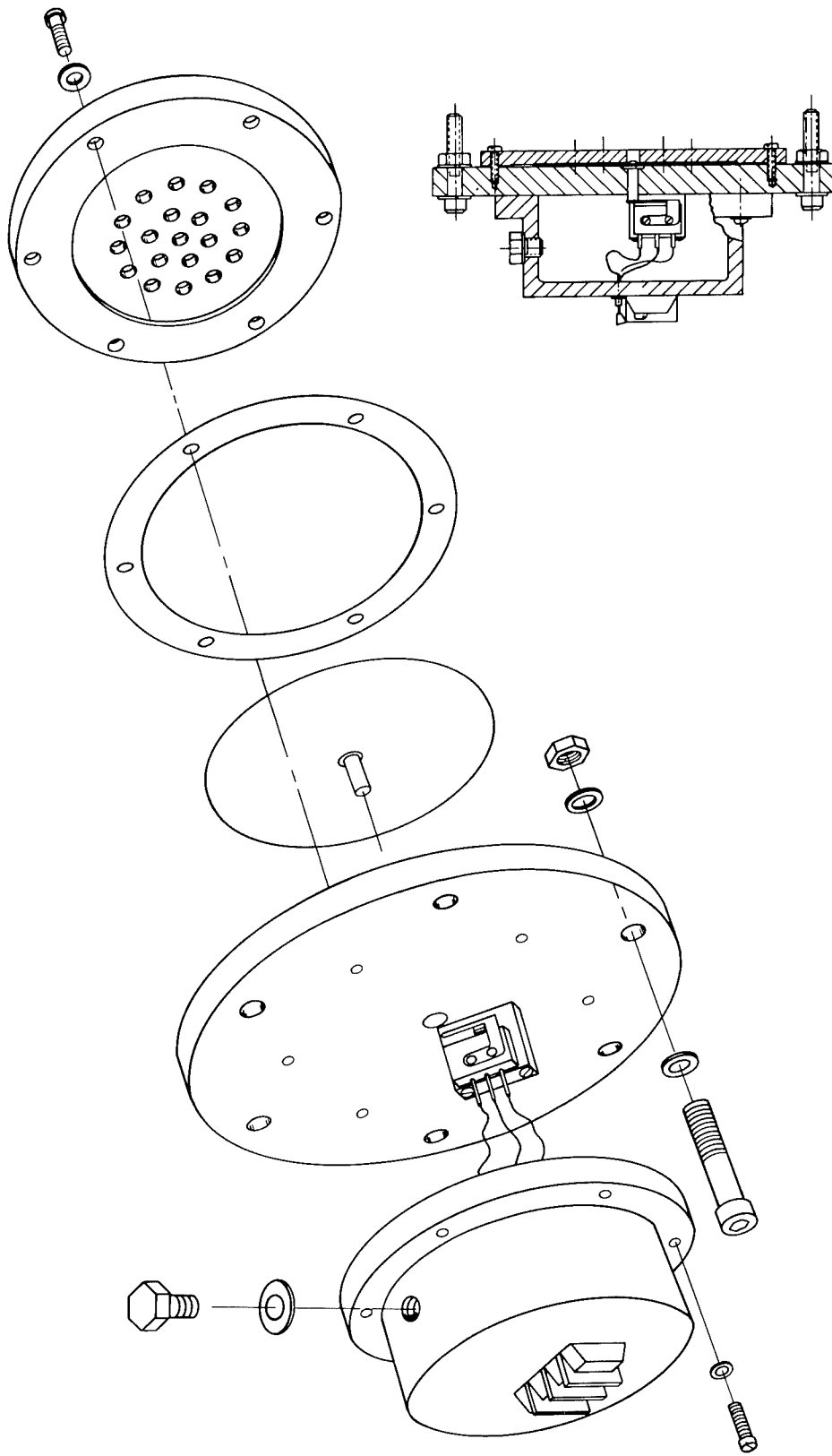

Figure 1.7. --Pressure switch components.

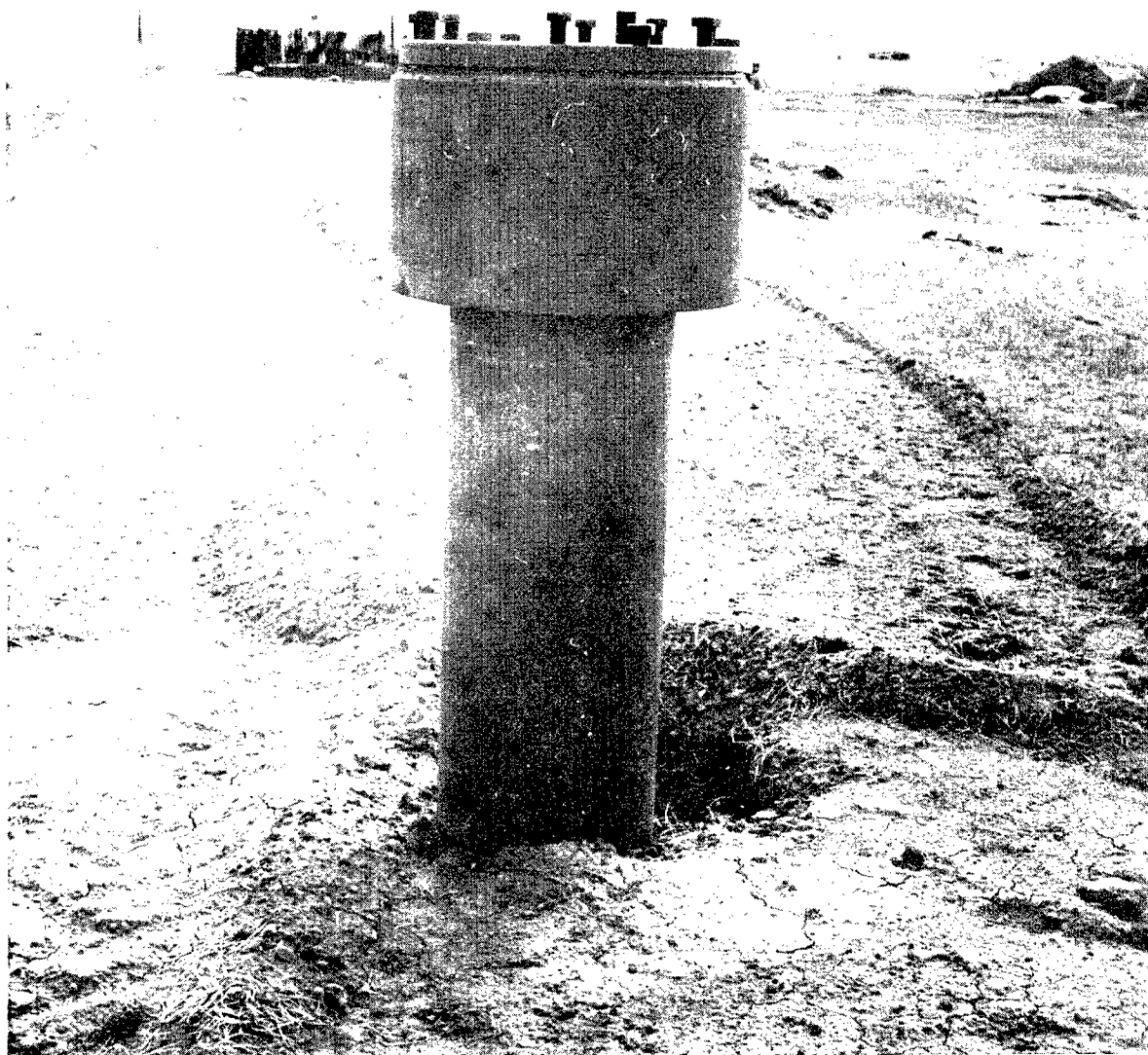

Figure 1.8. --Pressure switch support.

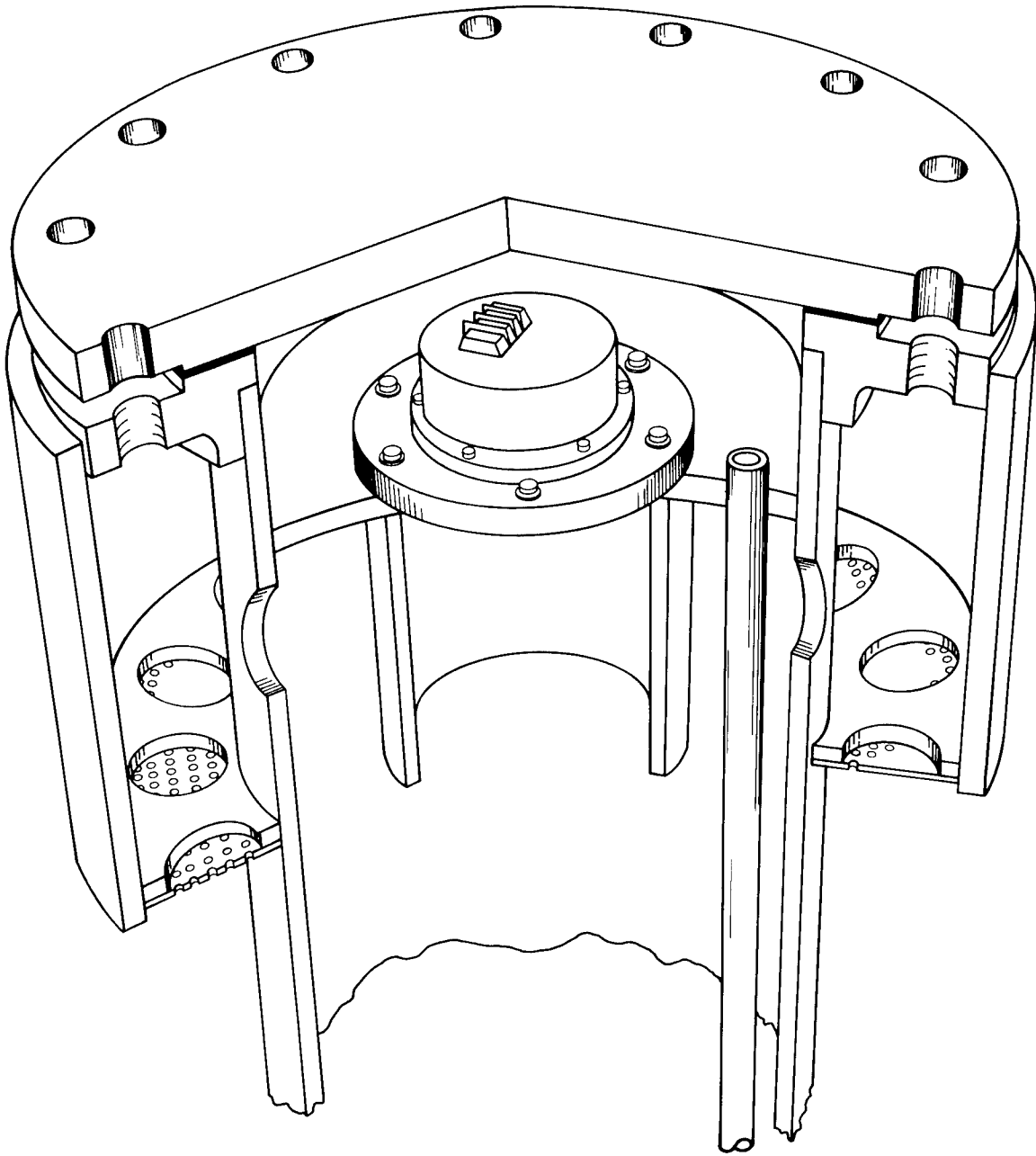

Figure 1.9. --Interior details of pressure switch support.

as typical locations for those found in underground buildings. Also, the plenums behind the valves simulated to some extent the downstream geometry found in many buildings. There, the plenums are not closed as in the test but have filter banks upstream from the large mechanical equipment room. Tests also allowed the simultaneous effects of ground shock to be imposed upon the valve. The only effects not simulated from a nuclear detonation were those of thermal radiation in EMP. Because the valves were mounted in an air shaft, thermal radiation was not expected to have any great impact. EMP might have some effect on the control system, but the control system is basically failsafe, and any malfunction should result in the valves closing.

This free-field test allowed the testing of a valve with all its controls: the pressure switch in its protective mounting, and the control unit which transforms the open circuit from the switch to a valve-closing signal.

The DIAL PACK Event provided basic design information on blast-closing valves, as well as information directly applicable to the 10-psi communication buildings. It was found that blast-closing valves could offer adequate protection for 10-psi buildings and that the failsafe blast closing of the louver valve resulted in only minimal downstream damage.

#### 1.3.4 Previous and Related Work.

The 1968 PRAIRIE FLAT Event was preceded by a series of tests on the louver blast valve. The first tests were conducted using a one-quarter-scale model. The tests, reported in reference 2, were conducted to determine the feasibility of this valve concept; to determine the mechanical performance of the valve, its closing time and maximum stresses; and to determine in a preliminary way whether or not a shock absorber was needed to arrest the slamming of the valve when driven by blast forces. Then full-size tests were conducted using the 6-foot shock tube at the Defence Research Establishment, Suffield, as reported in reference 1. These tests were used to check the one-quarter-scale results and also to obtain information on the lowest overpressures that would cause the valve to blast-close automatically. (That data was not obtained in the one-quarter-scale test.) Generally it was found that one-quarter-scale shock-tube results and the full-scale tests correlated. Reference 2 emphasizes the value of scale tests in this blast valve development.

The blast shutter is a proposed design for 2-psi blast-resistant stations. This design concept was tested using the Bell Laboratories Chester Shock Tube, as shown in figure 1.10. The tests demonstrated that the valve would survive 2-psi blast conditions with some moderate deformations. The shutter was reinforced and tested again. This time it was subjected to the effects that would be expected in a 10-psi free-field blast environment with the valve mounted in an air shaft. This would result in approximately a 6-psi incident pressure being propagated down into the shaft. When the shutter was blast-closed, the blades were indented where they hit the vertical ribs in the frame and were bowed between the ribs, but the damage did not prevent the shutter from closing successfully for one operation. It should be emphasized again that this blast shutter was not designed for 10-psi service--it was only used in this test to provide a much shorter duration pressure pulse which could be compared with the longer duration pulse that would escape through the louver valve.

Overpressures were obtained in shock-tube tests on a 1/30-scale model of the air shaft in the test structure. This scaled air shaft is shown in figure 1.11. At first, these tests were conducted to find out whether the results obtained in the PRAIRIE FLAT Event could be duplicated. Since the results were duplicated, data was then obtained for 50-psi shocks sweeping over the 1/30-scale air shaft. In PRAIRIE FLAT, because of a blast anomaly, only a 34-psi shock traversed the test structure rather than the predicted 50 psi. When these tests were being run, additional data was obtained on the pressures in this shaft for an approximately 10-psi wave sweeping across the air shaft. The results were compared with results obtained in the DIAL PACK Event.

1.4. PREDICTION MODELS. Some simple models discussed here explain the trend of the results observed in these tests.

#### 1.4.1 Plenum Pressures.

Figure 1.12 shows a simplified model of the pressure pulse that sweeps into the plenum behind the blast valve. Initially, a shock or a compression wave passes through the open valve as a consequence of the overpressure in the air shaft. Actual pressure records indicate a compression wave or a series of shocks, rather than a clean shock, propagating into the air shaft. As the valve closes, a rarefaction wave has to be generated to bring about the condition of



Figure 1.10. -- Shock-tube test of blast shutter (Chester, New Jersey Laboratories).

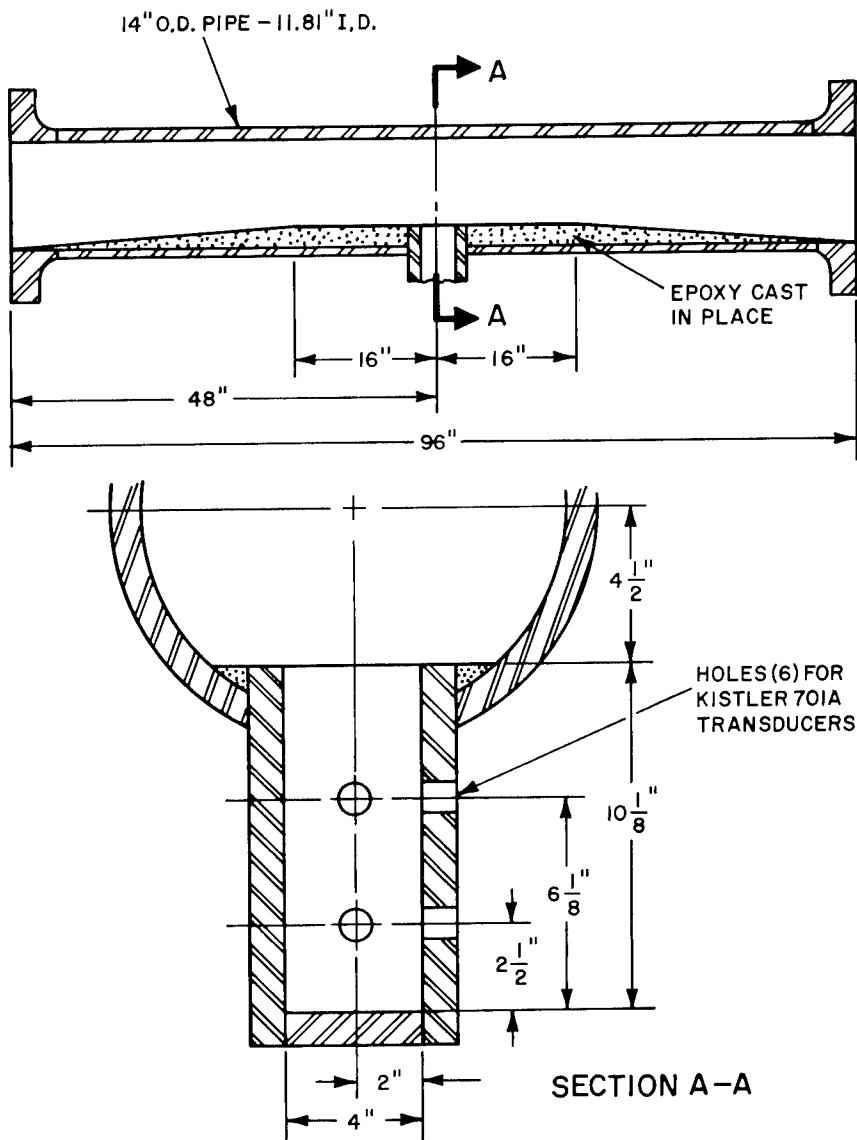

Figure 1. 11. --Schematic of 1/30-scale air shaft.

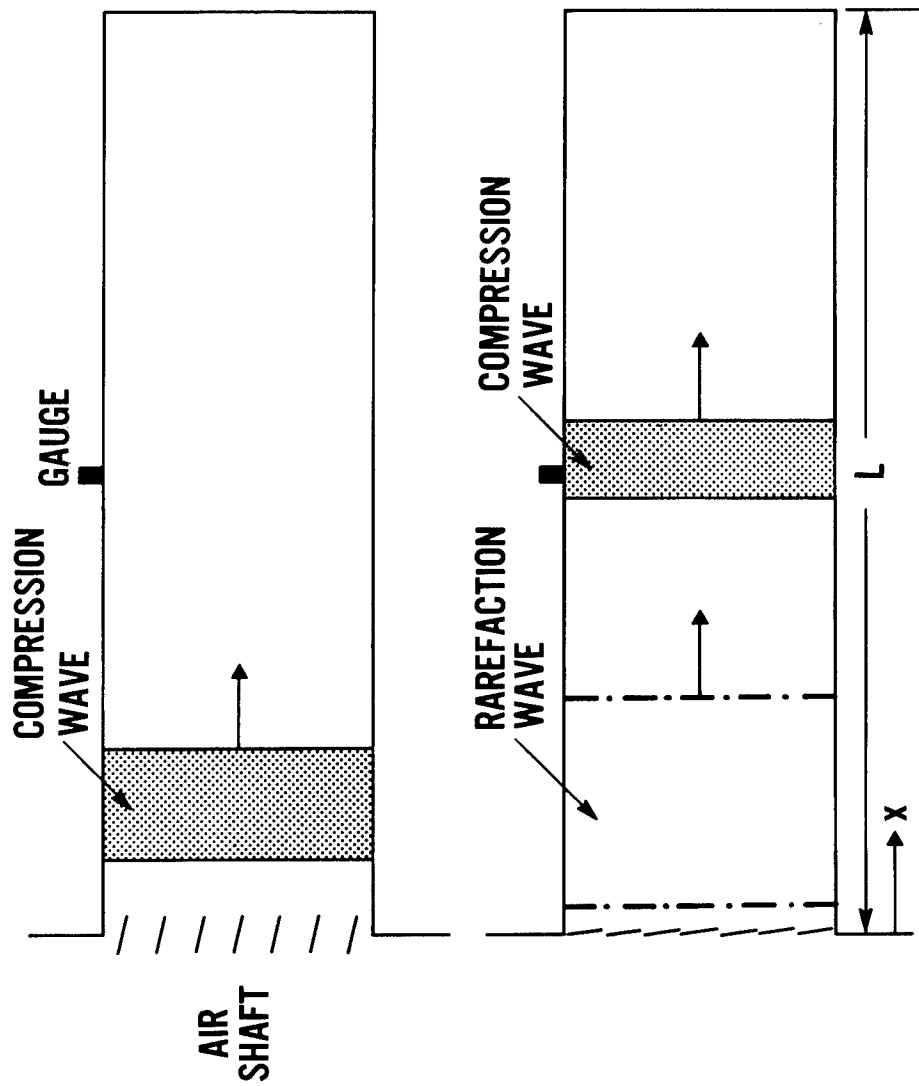

Figure 1. 12. --One-dimensional pressure pulse in plenum downstream of air shaft.

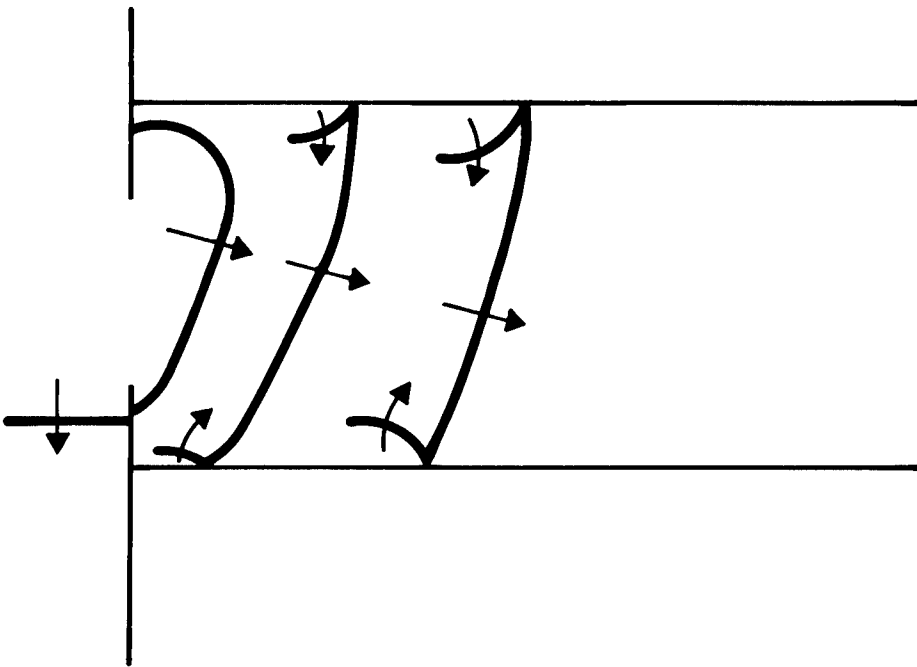

Figure 1.13. --Two-dimensional shock propagation into plenum.

no-particle-flow at the blast valve. If the valve had closed instantaneously, a centered rarefaction wave would have been generated. Since the valve closes in a finite period of time, the rarefaction wave must be generated over some period of time. Thus, two sets of waves--compression and rarefaction--will reflect and interact within the plenum, giving rise to a waveform-time-history. The details of this interaction are covered in chapter 3.

The magnitude of the incident overpressure in the plenum can be predicted using two steps, as shown in figure 1.13. The shaft overpressure forces a shock to be formed in the valve opening, the magnitude of which is predicted by one-dimensional shock-tube theory. This shock then enters the plenum and expands because the valve opening is smaller than the plenum cross section. Finally the expanding wave reaches the sides of the plenum and propagates into the plenum itself. The predicted reduction in overpressure from the blast-valve opening to the plenum is taken from reference 3.

#### 1.4.2 Duct Indentation.

In the previous model that was described in a preliminary report on the DIAL PACK Event, the overpressure impulse on the duct was used as a damage criterion. That model assumed the limits for duct survival to be the point at which the sheet-metal walls--assumed to be simply supported plates--reached their yield strength. This is overly conservative. Figure 1.14 presents similar information but considers deformations of plates occur well into the plastic region.

The following comparisons are made between the data in figure 1.14 and deformations just to the elastic limit. For an 18-gage steel plate, 2 feet wide,\* 0.5-psi static loading produces stresses to the elastic limit. A 1.2-psi peak-pressure pulse with a duration of 0.02 second will cause a 5-inch deformation; and a 0.7-psi pulse will cause a 2-inch deformation--a significant increase in duct resistance to blast. For 26-gage steel, a static load of 0.07 psi will produce stresses to the elastic limit. A 0.2 peak-overpressure pulse with a duration of 0.02 second will cause a 5-inch deflection.

---

\*Edges assumed to be built-in.

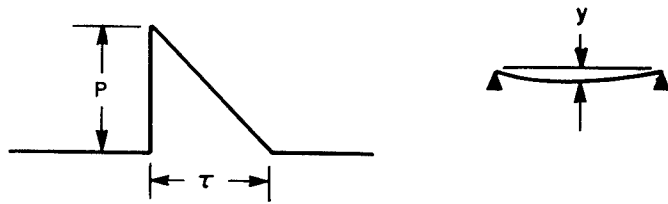
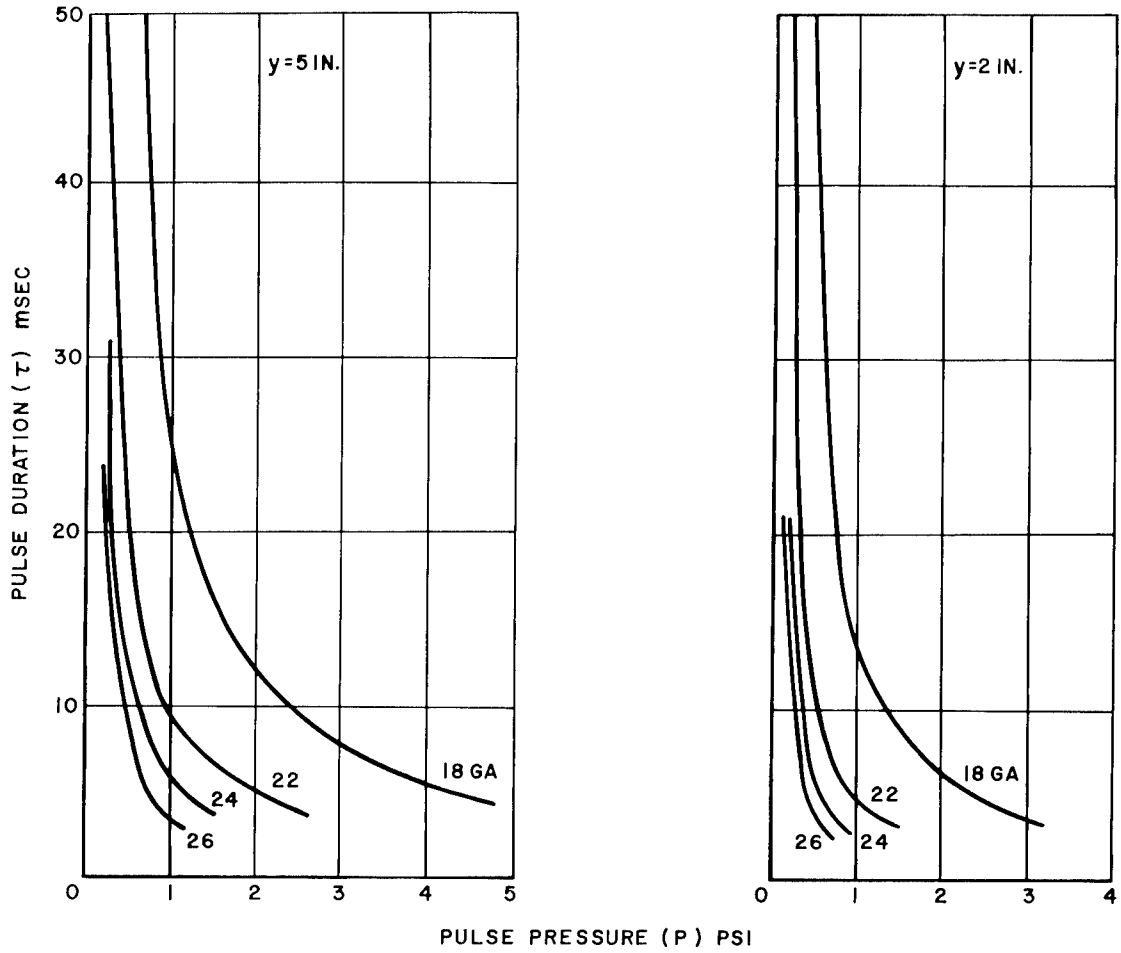

Figure 1. 14. --Elastic-plastic plate deformation.

Even such plastic behavior is not sufficient to explain the resistance of the 26-gage ducts, as is evident in these experiments. This simple model is therefore postulated: resistance of the duct is a combination of both the structural resistance of the metal and the internal pressure of the duct, which is generated as the duct deflects and partially collapses. The internal pressure buildup in the duct is assumed to be caused by isentropic compression of the air. The metal sheet adds little to the strength of a 26-gage duct. Strength is supplied almost entirely by the internal pressure of the duct. As the duct-wall thickness increases, more of the strength of the duct is transferred to the sheet metal. This model is developed in the appendix.

## CHAPTER 2

### PROCEDURE

#### 2.1. TEST STRUCTURE.

The test structure shown in figure 1.2 simulated part of a full-size underground building in which the blast valves would be located. The air-shaft opening was 10 feet by 10 feet, which is about half the area of a typical air shaft for a full-size underground building. This air-shaft opening area was of a reasonable size, since the test air shaft had two blast valves, while the full-size buildings usually have four blast valves for every air shaft.

The upper valve was approximately the same distance from the top of the shaft as would be the topmost valve in those underground buildings with two stories. Likewise, the lower valve was the same distance from the bottom of the shaft in the test structure as that for two-story underground buildings. The valves were mounted in 50-inch-diameter openings. The same type of openings exist in present buildings which were designed originally for poppet valves. (Use of the poppet valves was discontinued after the adverse test results, described in reference 4, which obtained in the SNOWBALL Event in 1964.) The plenums behind the valves are not exact simulations of those found in underground buildings because the actual geometry of the buildings includes baffle walls, filter banks, and large mechanical equipment rooms. Sufficient plenum space was provided, however, so that the overpressures acting on the filter banks could be measured.

The test structure in the PRAIRIE FLAT Event was located 560 feet from the charge. Fifty psi was predicted at this location, while only 34 psi was actually measured, because of a blast anomaly. The azimuth bearing was 240 degrees. In the DIAL PACK Event, the same structure was located 970 feet from the charge. A 12-psi peak free-field pressure was expected and measured. The azimuth bearing for this location was 142 degrees. The actual blast direction was rotated approximately 90 degrees between these two events. In PRAIRIE FLAT, the blast direction was perpendicular to the wall on which the valves were mounted. In DIAL PACK the blast direction was parallel to that wall.

## 2.2. INSTRUMENTATION.

2.2.1 Location and Types. The locations of the instruments used in the DIAL PACK and PRAIRIE FLAT Events are shown in figure 2.1. Pressure gage locations are indicated by P, accelerometer locations by A, and soil-stress gage locations by SS. In the PRAIRIE FLAT Event there was a strain gage at the center of the middle rib of each louver valve (located as shown in figure 3.9). The characteristics of the transducers are summarized in table 2.1.

2.2.2 Calibration. Pressure-, acceleration-, and strain-gages were all calibrated 30 seconds before the blast by means of calibration circuit in the recording package. The calibration signal was generated by placing an unbalancing resistor in the bridge circuit. The values of the resistors in the pressure gage bridges were determined by applying air pressure to the mounted pressure gages. Air was supplied from a portable tank fitted with a regulator, a solenoid valve, and a 200-psi Heise bourdon-tube gage. The air pressure was regulated to the calibration level, and the calibrating resistor was adjusted so that it produced the same bridge unbalance as the loaded pressure gage. The value of the strain gage and accelerometer calibration resistors was obtained using gage factors. Accelerometers were checked at the Whippany Laboratory just before the test. They were checked in the range of 50 to 300 hertz and were accurate to within  $\pm 2$  percent at 100 Hz.

2.2.3 Transducer Mounting. The pressure transducers were flush-mounted as shown in figure 2.2. The front plate, holding the screw-type pressure transducer, was secured by three screws to a receptacle cast in the concrete. These flat-head screws were removed one at a time and replaced with studs when the pressure calibration test was performed. These studs were used to hold the adapter (also shown in figure 2.2), which applied pressure to the face of the pressure gage. The air seal was provided by an O-ring gasket which was held between the adapter and the face of the gage mounting plate. Accelerometers were mounted to the concrete surfaces as shown in figure 2.3.

### 2.2.4 Recording Package.

All data from the experiment was recorded in nearby recording packages, like the one shown in figure 2.4. Two such packages were used in the PRAIRIE

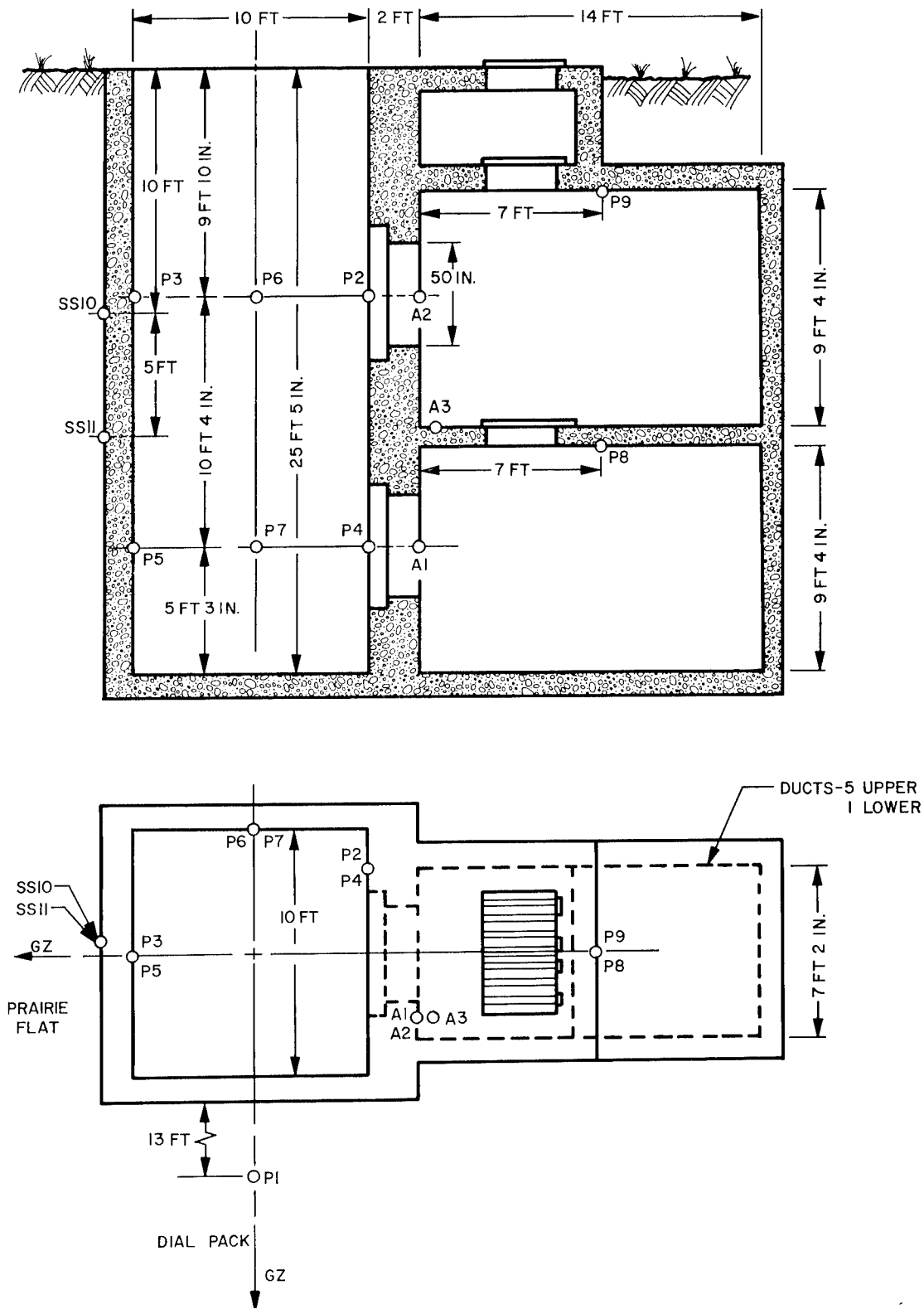

Figure 2.1. --Transducer locations.

Type	Location Code	Prairie Flat	Dial Pack	Model	Range	Natural Frequency	Calibration Level
Pressure	P1	X		BYTREX HFH100 ↓	(psi) 0-100	(kHz) 30	50 psi
	P2	X					50 psi
	P3	X					50 psi
	P4	X					50 psi
	P5	X					50 psi
	P6	X					50 psi
	P7	X					50 psi
	P8	X					50 psi
	P9	X					50 psi
				BYTREX HFH50	0-50	30	5 psi
				BYTREX HFH50	0-50	30	15 psi
				↓ BYTREX HFH50* ↓			25 psi
							25 psi
							25 psi
							25 psi
							25 psi
							25 psi
							10 psi
			10 psi				
Strain	V1	X					1000 μ in/in
	V2	X					1000 μ in/in
Valve Position	V1	X		Lin. Pot. Pal. Scientific RPO4-0101-1	(in) 0-4	-	-
	V2	X					-
	V1		X	Microswitches	-	-	-
	V2		X				-
Acceleration	A1	X		STATHAM A3-25-350 ↓	±25G	225 Hz	10g
	A2	X					10g
	A3	X					25g
Soil Pressure	SS10	X		Supplied by WES*			50 psi
	SS11	X					50 psi
Camera		X		HYCAM			

\*Inoperative.

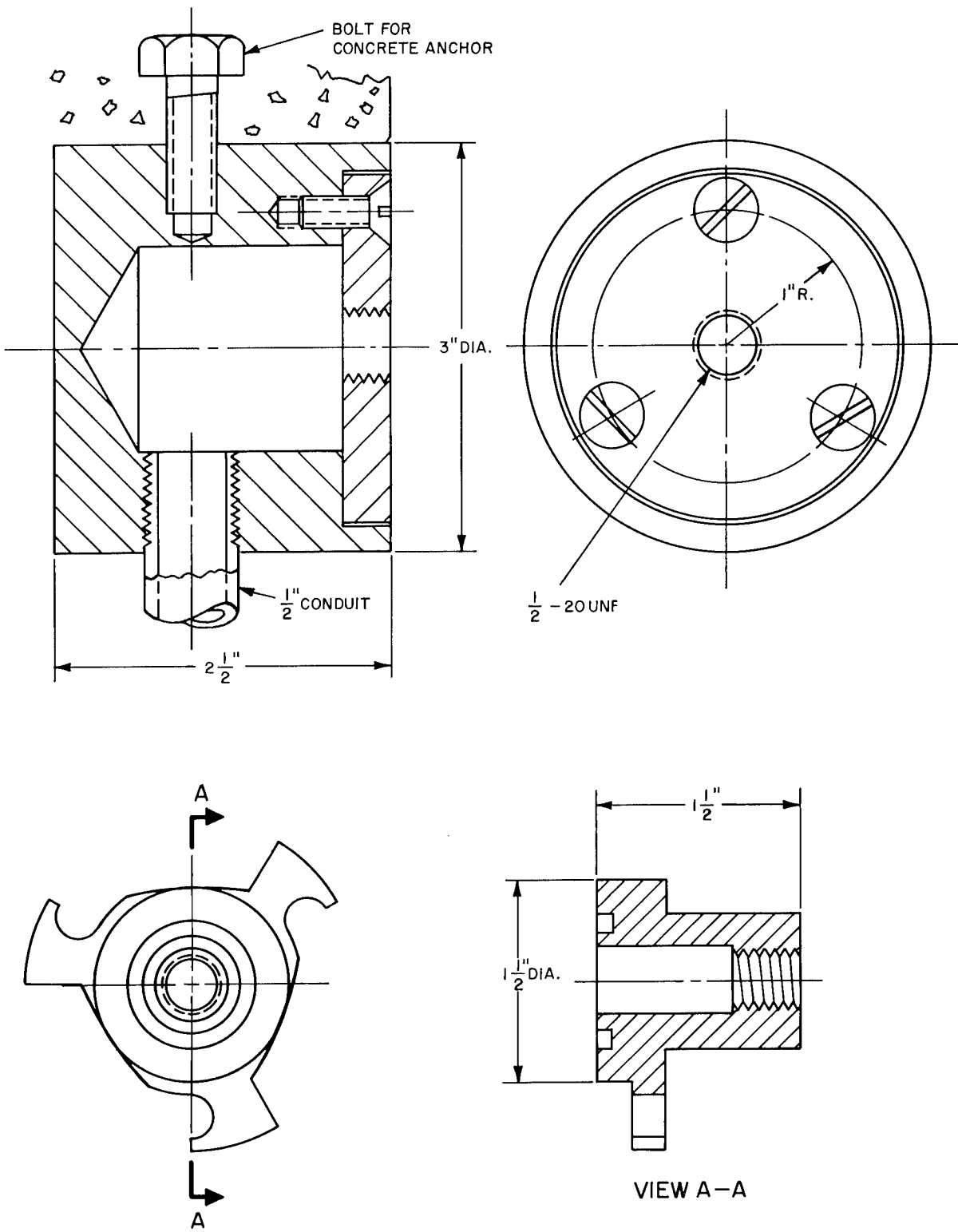

Figure 2.2. -- Pressure-gage mount and testing fixture.

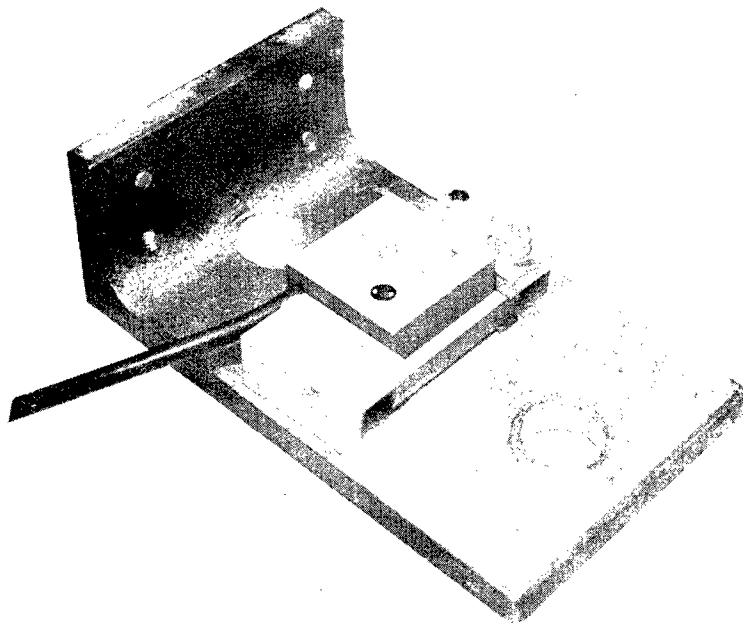

Figure 2.3. --Accelerometer on mount.

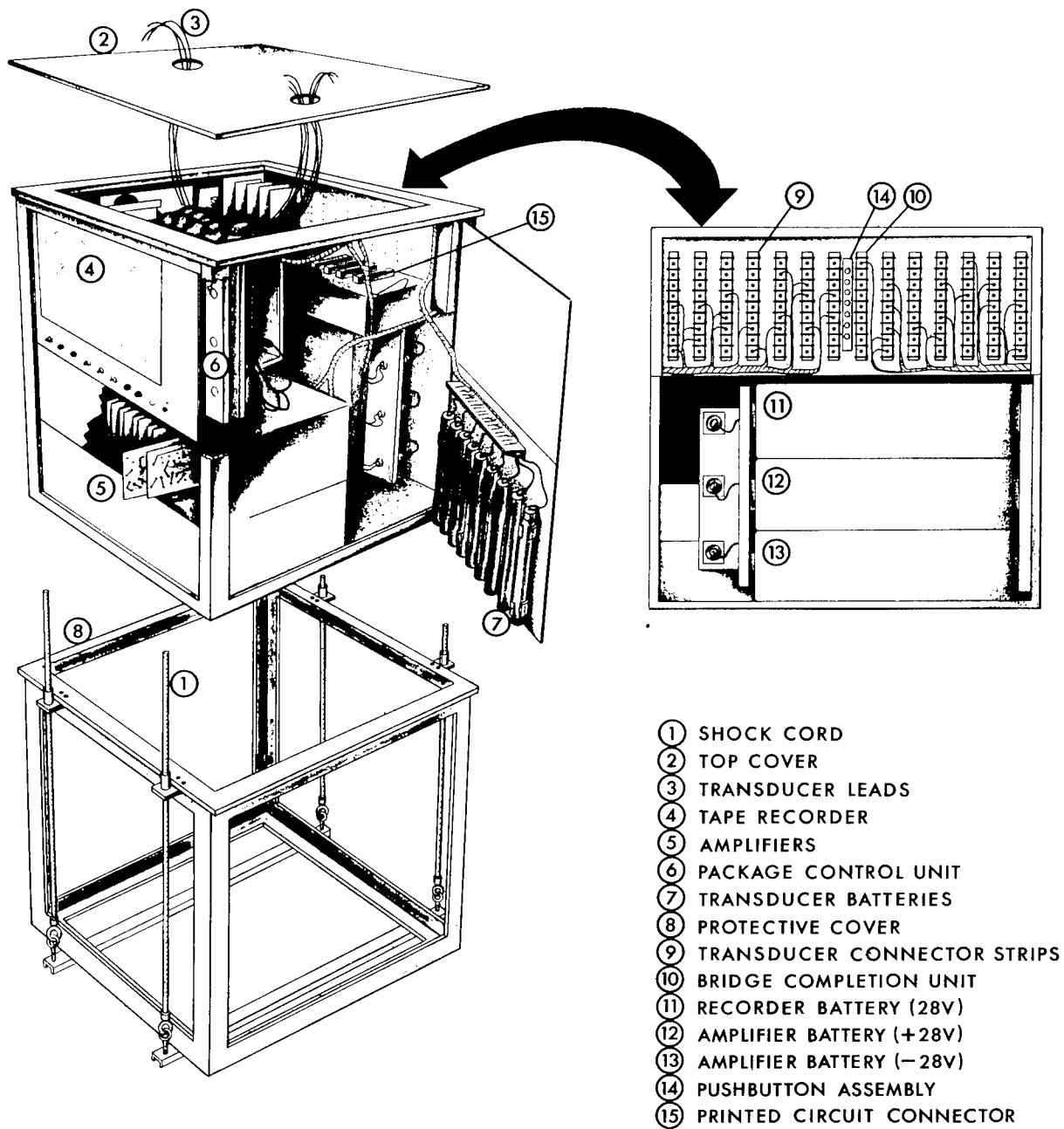

Figure 2. 4. --Recording package.

FLAT Event, and one in the DIAL PACK Event. The package described in detail in reference 5 consists of a Pemco Model 110, 14-Track Recorder; 14 Model-115 Astrodata preamplifiers, and bridge-completion and -calibration circuits for the 14 channels. It also contains a timing generator. Power for all this equipment is supplied by three 28-volt nickel-cadmium batteries.

The recording packages were designed to satisfy three requirements: they were to be placed close to the experiment in order to eliminate long transducer leads; they had to survive the blast effects without damage; and they had to be remotely operated. Survival was guaranteed by suspending the packages from shock cords, within a steel bunker. The packages--approximately 22-inch cubes weighing about 215 pounds--were each suspended on four 1/2-inch-diameter shock cords with a free length of 28- to 30-inches. The shock cords held the packages approximately in the center of the steel bunkers, which were about 4 feet in diameter and 7 feet deep.

The recording packages were remotely operated from the range control console. At minus five minutes, the signal was sent to turn on the power. At minus one minute, the tape transport was started. At minus thirty seconds, a calibrate signal was recorded. That signal automatically dropped off, and in DIAL PACK only a time-zero signal was recorded for reference. The unit automatically shut off at 1 minute after time zero. The recording packages had a bandwidth of 0 to 10 kHz and a total running time of 5 minutes, with a tape speed of 30 inches per second.

## 2.3. EQUIPMENT FOR TEST.

### 2.3.1 Blast Valves and Controls.

The hatches in the test structure (shown in figure 1.2) were wide enough to accommodate the louver blast valve. Each valve was lowered by crane through the hatches into its appropriate test structure. There, the valve was set on the floor. The lifting cable was then taken off and placed through openings in the structure, allowing the blast valve to be lifted next to the inside of the air-shaft wall. The blast valve was lifted into position and bolted firmly to the wall with 1-1/8-inch-diameter threaded rods, 39-1/4 inches long. Eight rods were used to hold the blast valves in the PRAIRIE FLAT Event (as shown in figure 2.5), and four rods were used in the DIAL PACK Event because of the different



Figure 2.5. --Installed louver blast valve as viewed from  
air shaft, PRAIRIE FLAT Event.

configuration of the valve-frame housing. Four adapter plates were required for each valve in order to provide an anchor for the rods. Nuts on the rods were tightened to about 300 foot-pounds to preload the valves to the wall.

A large adapter plate was needed to mount the blast shutter to the existing blast-valve opening in the test structure. This plate was bolted fast by four rods to the inside surface of the air-shaft wall on the plenum side, just as was done to hold the louver valve in position. The adapter plate had a 30-inch-square opening cut into it, and the blast shutter was bolted to this plate. In addition, a brace was placed across the center of the blast shutter to give additional support to the cross ribs. An installed blast shutter, viewed from the plenum chamber, is shown in figure 3.11. That is a postshot photograph, and some of the damage caused by the blast is evident.

The lower louver valve in the PRAIRIE FLAT experiment was closed before the blast arrived at the air shaft. The signal to start closing the valve was originally generated by a pressure switch placed 400 feet from ground zero in the mount shown in figures 1.8 and 1.9. The expected peak overpressure at that location was 150 psi. The supporting pipe for the structure was 8 inches in diameter, had a 1-inch-thick wall, and the entire assembly stood out of the ground approximately 4 feet. The pipe extended approximately 4 feet into the ground. The control cables were buried in a trench leading right up to the pressure switch pedestal. The control units were rigidly mounted in the lower plenum, as shown in figure 1.5.

### 2.3.2 Sheet-Metal Ducts.

Sheet-metal ducts can be considered passive instrumentation because they were placed in the plenums so that blast inflicted damage could be observed. All ducts had the same outside dimensions and construction, as shown in figure 2.6. After the PRAIRIE FLAT Event, it was found that at least one duct had a plain slip joint instead of a drive slip joint across one of the long sides, which resulted in the seam parting where subjected to blast forces.

The various ducts tested are also shown in figure 2.6. The 6-foot edges were always vertical. The ducts in the upper plenum were strapped to the walls, while those in the lower plenum were free standing.

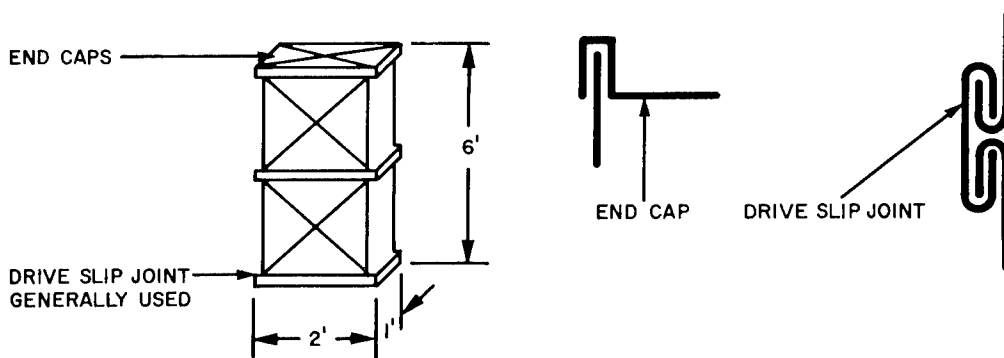
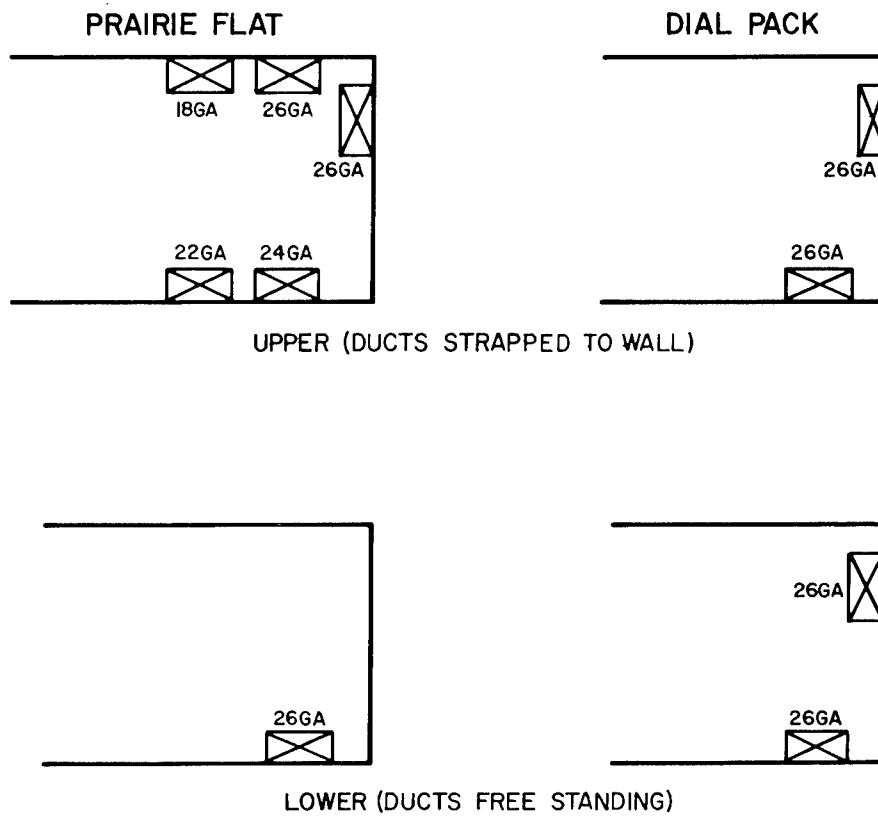

DETAILS

Figure 2.6. --Duct construction and test locations.

2.4. FINAL FIELD OPERATIONS. The day before the PRAIRIE FLAT shot, all recording equipment was lowered into bunkers. However, the shock cord was not lowered because wires were used to take the load of the equipment. It was suspected that the shock cord could creep sufficiently to allow the equipment to settle to the bottom of the steel bunkers. Lifting up the packages and removing these temporary supports was an extensive operation on shot day, and it consumed the activity of several people for several hours. In the DIAL PACK Event, a different technique was used. It was found that the shock cord would not creep during a 1 or 2 day period, and all equipment was lowered on its shock cords and made completely ready for the shot a day before the event. Essentially no field operations were required on shot day in DIAL PACK.

## CHAPTER 3

### RESULTS AND DISCUSSION

#### 3.1. FREE-FIELD OVERPRESSURES.

Free-field overpressures are shown in figure 3.1. The PRAIRIE FLAT data certainly exhibits a nonclassical type of waveform as a result of a blast anomaly which occurred near the test structure and which was observed in photographs. The peak overpressure predicted at the location of the test structure was 50 psi; however, as seen in figure 3.2, only a 34-psi peak pressure was measured. There was an advantage in this blast anomaly; the wave was almost flat-top for about 30 milliseconds. That meant that, during the period of time when the shock was traversing the depth of the air shaft, the test structure was actually being subjected to the effects of a long duration blast such as would result from a nuclear bomb explosion.

The data from the DIAL PACK Event is much closer to ideal predictions, and it compares very favorably with two measurements recorded at the Ballistics Research Laboratory at two other azimuth locations near the same ground range.

#### 3.2. AIR-SHAFT OVERPRESSURES.

##### 3.2.1 PRAIRIE FLAT Results.

Measurements of air-shaft overpressures resulting from the 34-psi free-field overpressure are shown in figure 3.2. A small inset provides a ready reference to locate the positions of the gages whose records are reproduced here.

There was an immediate reflection at P2, the gage location alongside the upper valve. The reasons for that reflection are apparent from figure 3.3, which shows the pattern of waves traversing the air shaft, as constructed from PRAIRIE FLAT results. As the shock wave traverses the air shaft, an expanding wave is forced down the shaft. That wave reflects from the back wall--the wall in which the blast valves are mounted--and gives rise to the initial peak pressure at P2. That incident shock and its reflection causes a two-step incident wave to appear at all pressure locations except P2 and P4, which are on the plane of reflection (see figure 3.3). The first shock varies between 8 psi and 12 psi, and the peak of the second shock varies between 19 psi and 25 psi. The wave fronts shown in

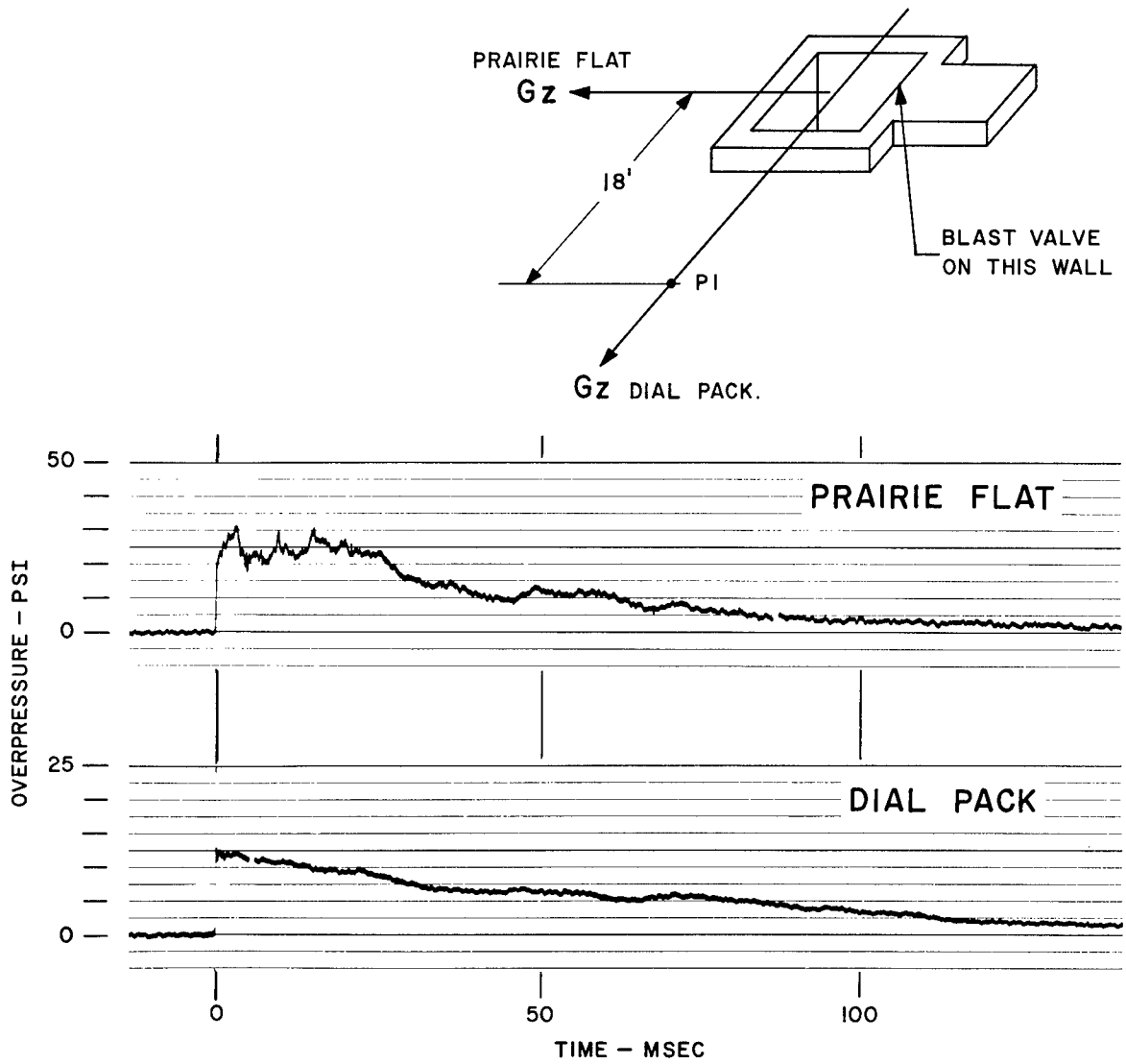

Figure 3. 1. --Free-field overpressures as measured at location P1.

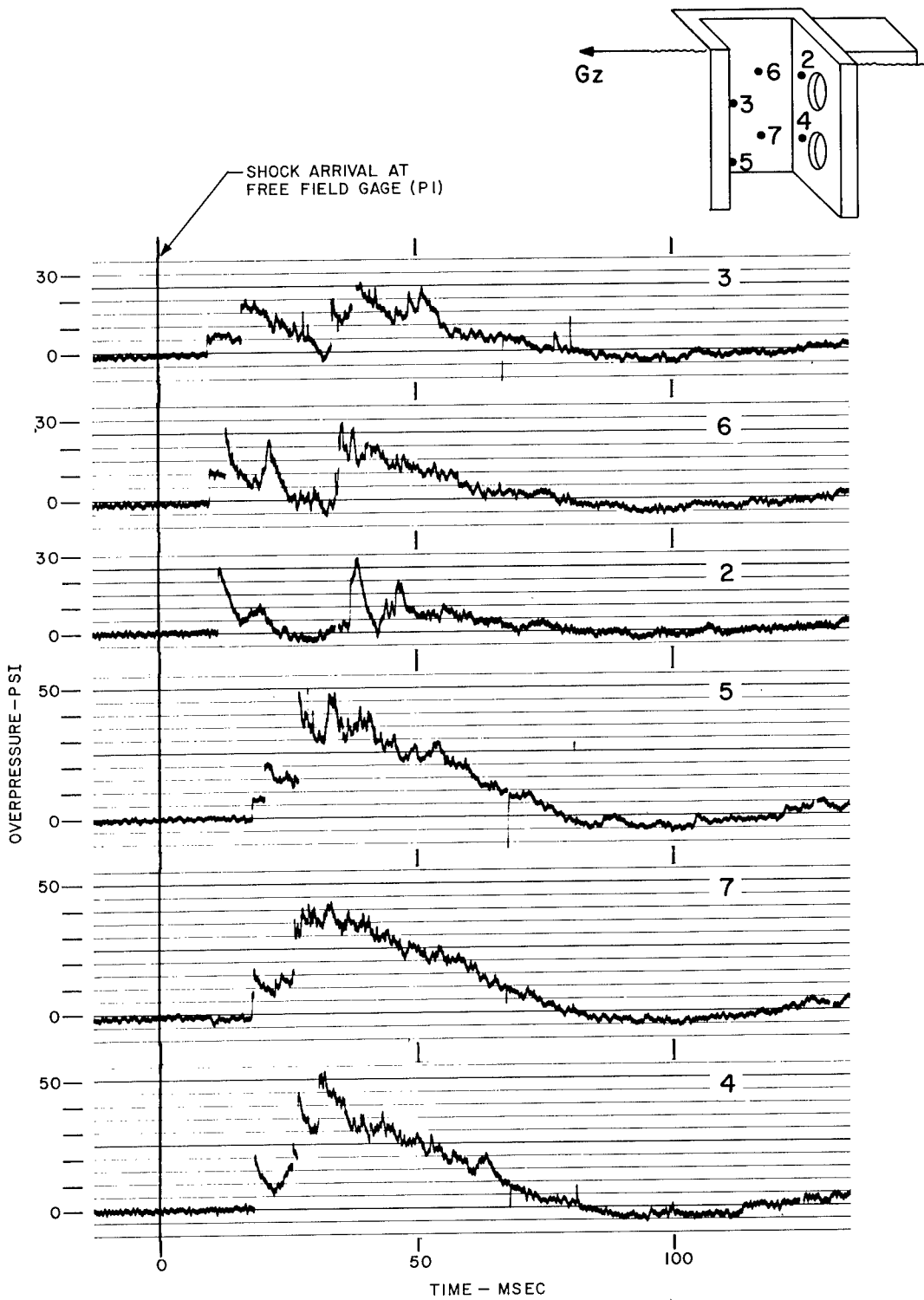

Figure 3.2. --Air-shaft overpressures, PRAIRIE FLAT Event.

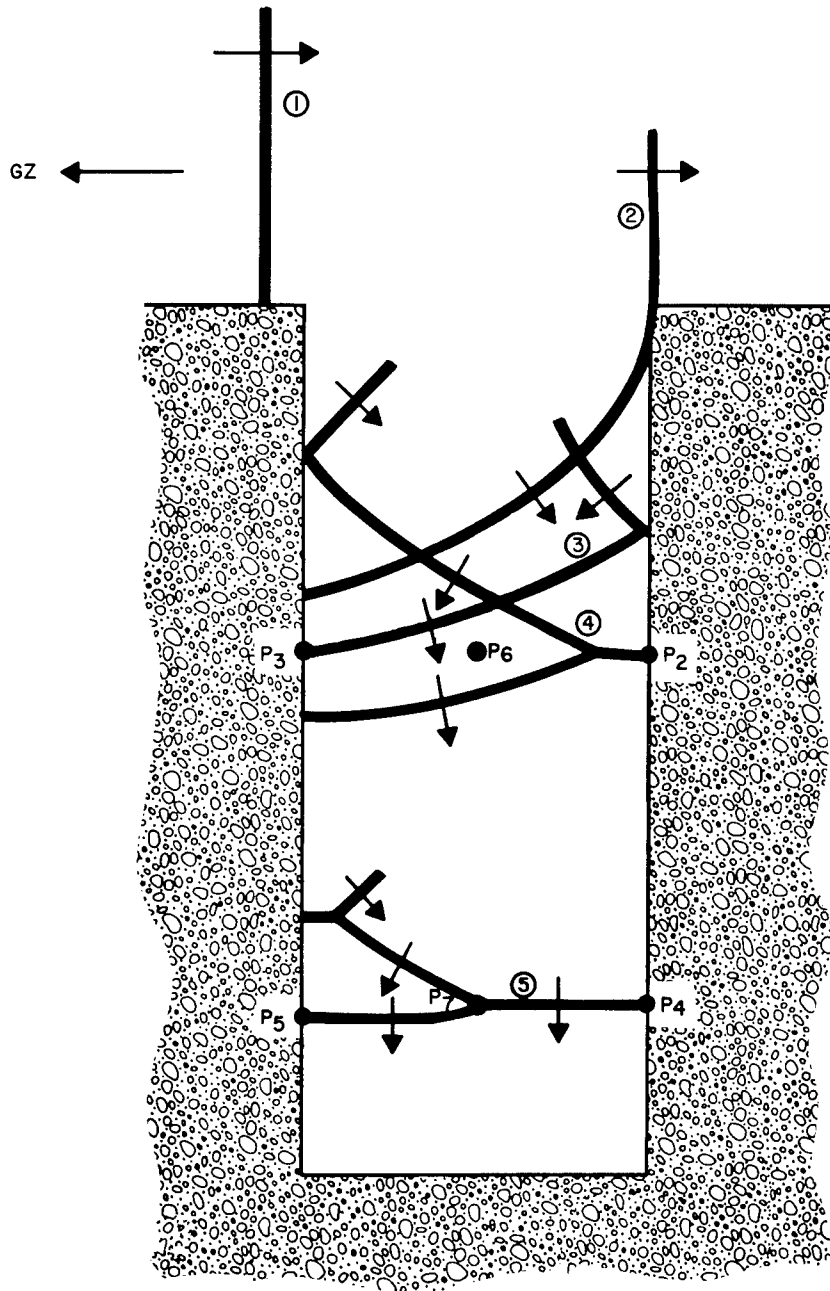

Figure 3.3. --Shock patterns in air shaft, constructed from PRAIRIE FLAT Event results.

figure 3.3 are approximate, but they are based upon actual phase differences observed in the pressure records.

The data in reference 6 leads to the prediction of a 16.3-psi shock overpressure after about five tunnel diameters have been traversed. That minimum distance is required to stabilize the shock into a common front. It is obvious that in this short shaft, which is only 2-1/2 diameters deep, the shock front has not been completely stabilized. The measured overpressure for the second incident peak was a little higher than that which is predicted in reference 6. When the two incident waves merge, the combined shock has a slightly lower pressure (above ambient) than that which occurs behind the second shock. The reduction, less than 1 psi, would not bring the observed pressure down to the predicted value. The wave system was reflected from the bottom of the shaft, and the resulting peak pressure measured was about 50 psi. A 20-psi shock, the approximate value of the second incident peak, would reflect to about 61 psi, which is in excess of what was observed. A 16-psi shock, the predicted value of the wave system, would reflect to about 47 psi, which is about the same as the pressure actually measured in the experiment.

### 3.2.2 DIAL PACK Results.

The blast direction in the DIAL PACK Event was rotated about 90 degrees with respect to the test structure, so that the blast valves were now located on a wall of the air shaft which was essentially in line with ground zero. The pressure records obtained in this experiment are shown in figure 3.4. A single incident wave with a 6-psi peak was observed at P7 in this case, on the back wall of the air shaft. The double-step incident waves are apparent in the recordings made on the side walls of the blast valves, at P2, P4, and P5.

The phase relationship between the arrival of the incident wave and its reflection at P4 is different from that at P5. That is explained somewhat by the geometry of the gage locations. Although P4 and P5 were at the same elevation in the air shaft--at the center line of the lower valve--P4 was much closer to the back wall where the reflection occurred. Therefore, the time difference between the incident and the reflected waves would be less for P4 than for P5. Also, the presence of the blast valve had some effect on the waveform, probably causing the less sharp rise in the incident wave at P4. The predicted incident overpressure in the shaft is 7.8 psi for an ambient pressure of 13.6 psi and an

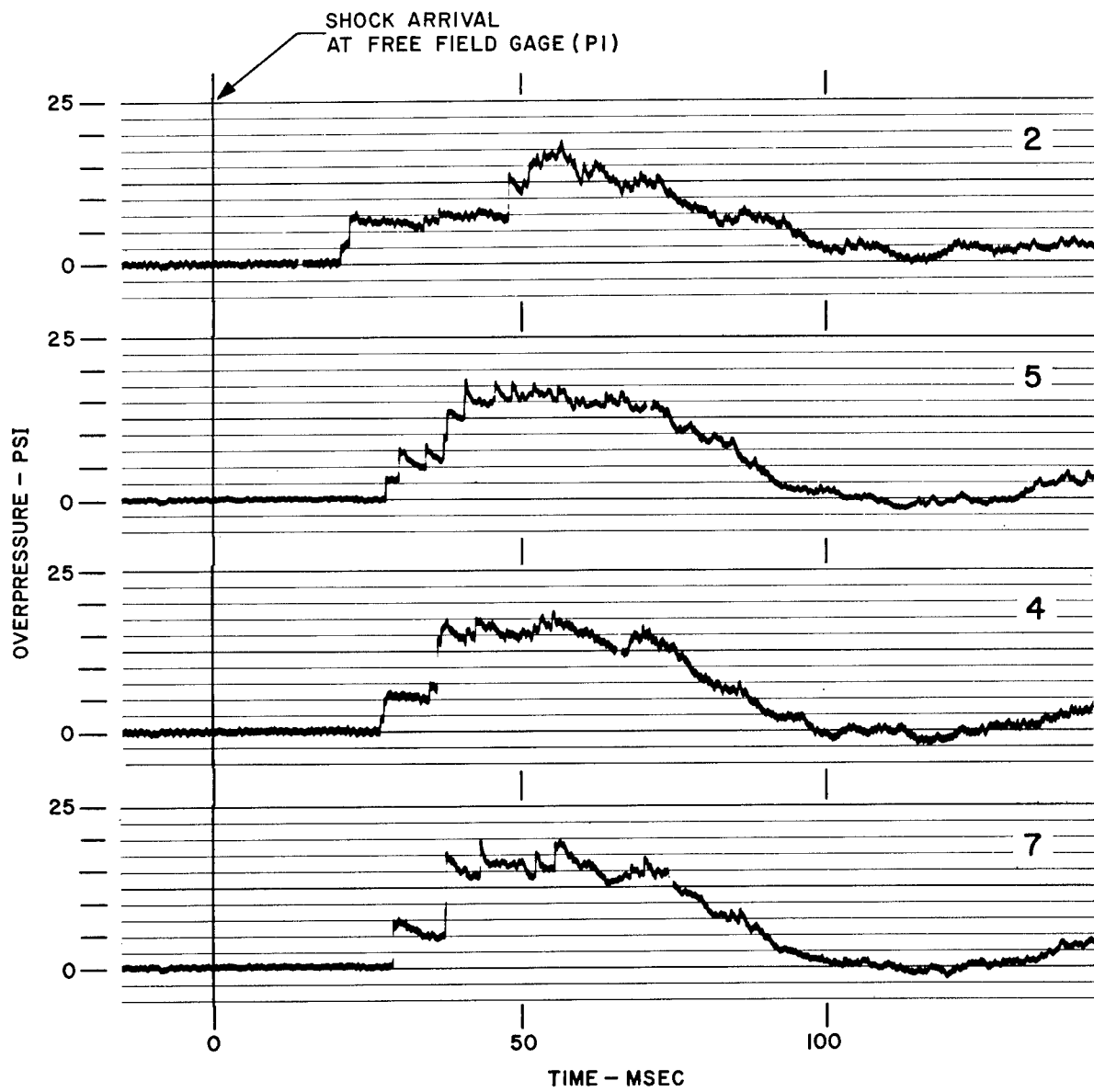
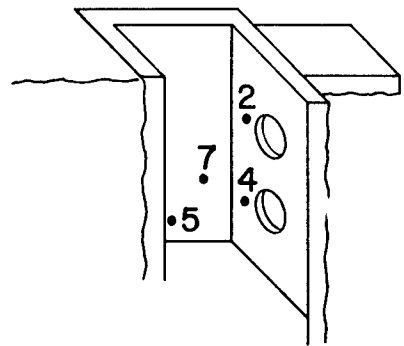

Figure 3.4. --Air-shaft overpressures, DIAL PACK Event.

incident free-field overpressure of 12.4 psi. Values between 6 psi and 8.3 psi were measured in this experiment, which compares well with the predictions. Peak-reflected pressures from the bottom of the shaft vary between 14 psi and 17.5 psi. A 6-psi incident would ideally reflect to 14.2 psi.

### 3.2.3 Comparison With Shock-Tube Results.

Figure 3.5 compares results obtained in PRAIRIE FLAT with the 1/30-scale shock-tube results for pressures in the vertical air shaft. The waveform and peak pressures are very well simulated in the scale shaft. The time scale for the shock-tube tests had to be expanded by 30--one millisecond in the actual record equals 30 milliseconds full scale--because of the scaling factor. Zero time on the shock-tube records was displaced slightly so that the curves would not overlap. Similar data for a 12-psi free-field overpressure is presented in figure 3.6.

In the full-scale tests in DIAL PACK, not all transducer locations were equipped with pressure gages. There were no gage mounts on the wall closest to ground zero in the DIAL PACK test. That wall was one of the side walls in the PRAIRIE FLAT test, and the gage mounts were placed on the symmetrically opposite wall in that test. That wall was furthest from ground zero in the DIAL PACK test. In addition, two gages, at locations P3 and P6 in DIAL PACK, were disabled by moisture before the event, and no data was obtained from them. It was discovered that both gages had been defective before the test, but there was not sufficient time to replace the gages. The lost data was not critical because of the good simulation of free-field results in the shock-tube tests, which is evident in figure 3.6. The missing pressure data in DIAL PACK was supplied by the shock-tube results, and full-scale tests are not needed to supplement that data.

3.3. VALVE PERFORMANCE. Valve performance was of primary concern in the PRAIRIE FLAT test and of secondary concern in the DIAL PACK test.

#### 3.3.1 Louver Valve.

The louver valve at the lower location in PRAIRIE FLAT was closed by the control system, well ahead of blast arrival at the valve. Valve position versus time is the lower trace in figure 3.7. The valve closed in approximately 45 milliseconds, as predicted. It started to close approximately 74 milliseconds before the blast arrived at the free-field gage. The pressure switch was located

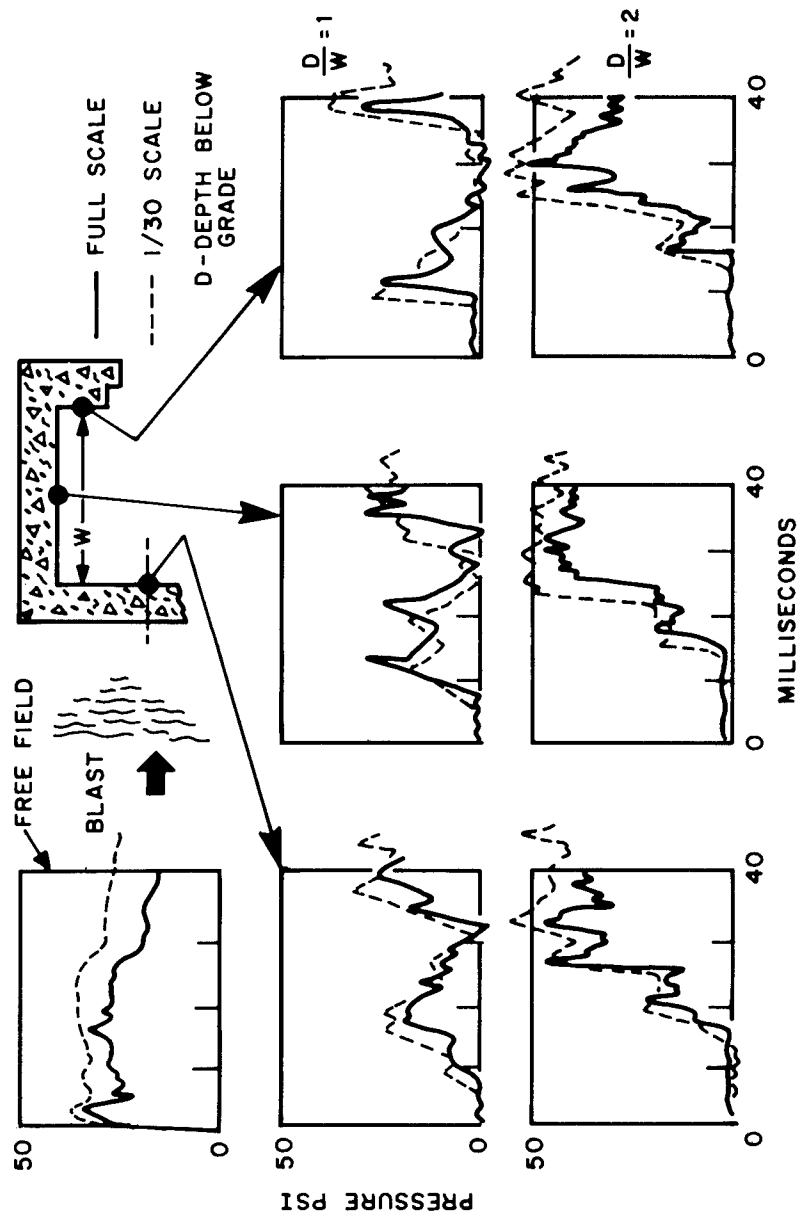

Figure 3.5. --Comparison of shock-tube data and the PRAIRIE FLAT Event data.

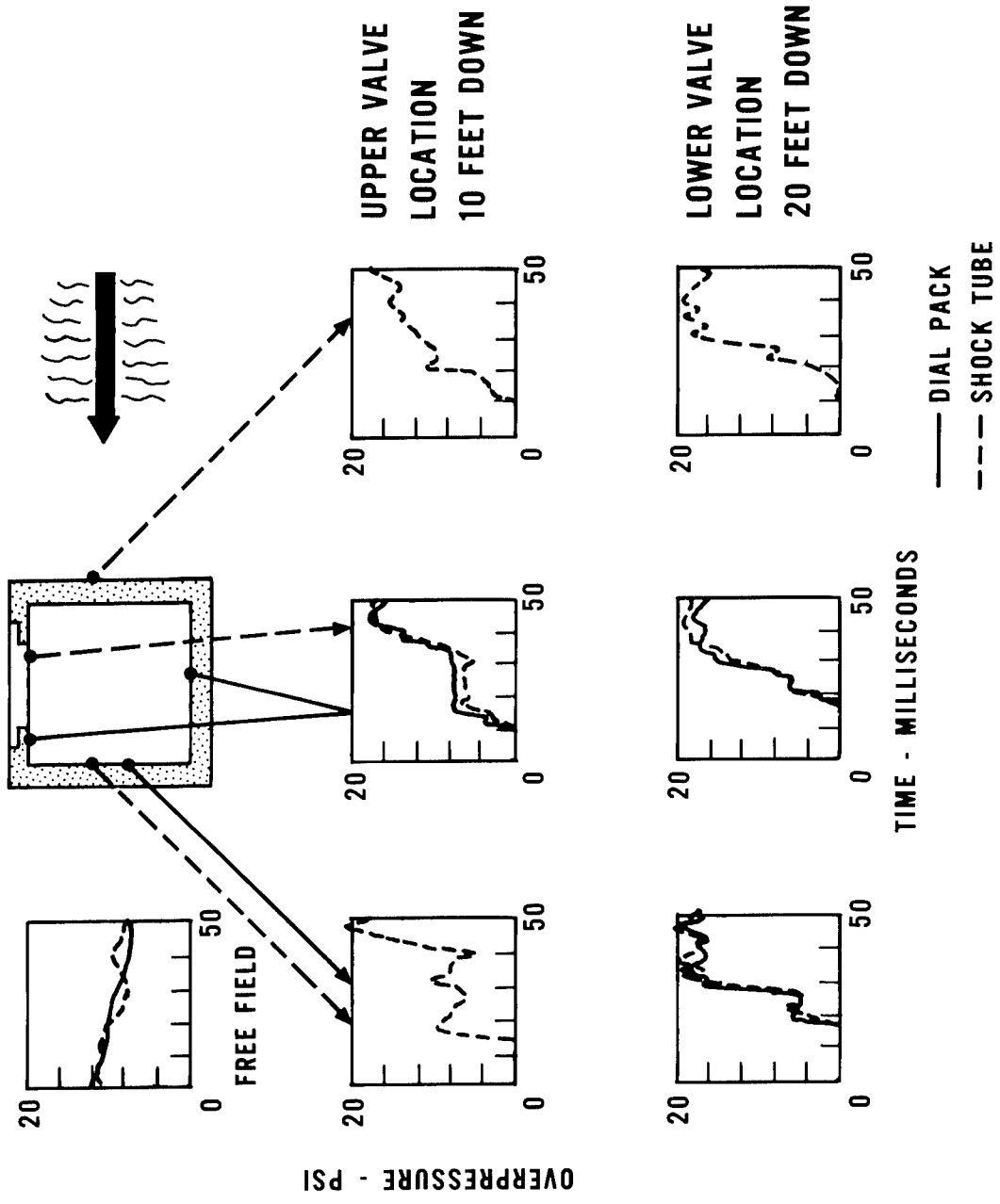

Figure 3.6. --Comparison of shock-tube data and the DIAL PACK Event data.

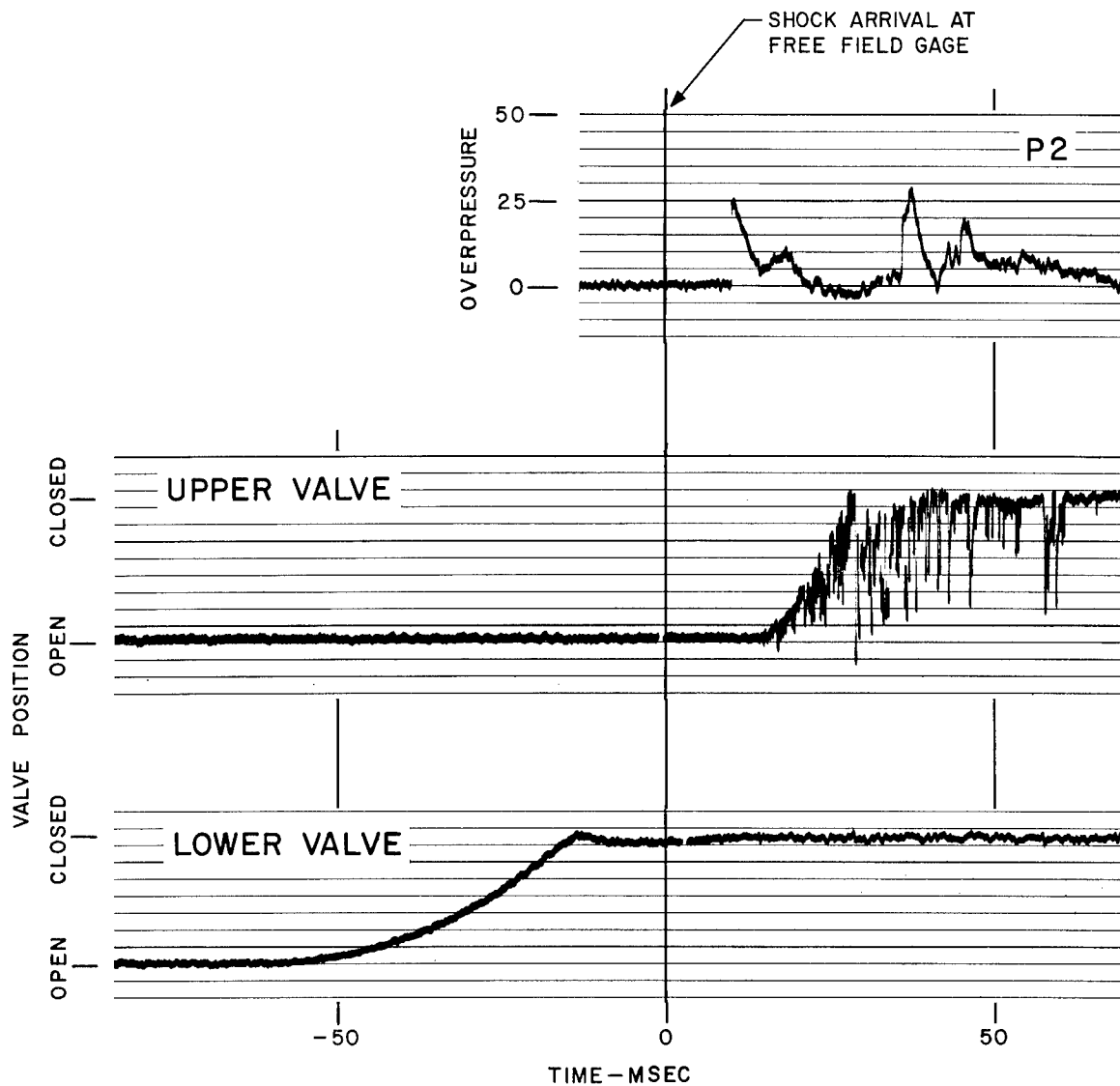

Figure 3.7. --Valve position versus time data for the PRAIRIE FLAT Event.

400 feet from ground zero; the test structure at 560 feet. Travel time between these two stations was predicted to be 54 milliseconds. Approximately an additional 15 milliseconds would be required for shock travel from the air-shaft entrance to the lower blast valve, bringing the total elapsed time to 69 milliseconds, compared with the 74 milliseconds measured. Because the blast hitting the structure had a lower overpressure than predicted, its speed of propagation was less. Therefore, the longer than predicted measured time is in agreement with the lower than predicted overpressures measured in the vicinity of the test structure.

The blast-closed louver valve in the upper location at PRAIRIE FLAT closed in approximately 14 milliseconds, as can be seen in the upper trace in figure 3.7. That was the same closing time that was observed in the 6-foot shock-tube tests at the Defence Research Establishment, Suffield (DRES) when the valve was subjected to a side-on incident overpressure of 18 psi, as reported in reference 1. The louver valve in the upper location in DIAL PACK blast closed in approximately 20 milliseconds. The closing time is indicated in figure 3.8 as the difference between shock arrival and switch closure. The intermittent contacting of the switch may have been the result of valve rebound and bending of the switch bracket. The latter caused the switch to indicate the valve open when it was known to be closed. No data on closing position versus time is available for the DIAL PACK Event because only microswitches were used in that test. The closing-time data compares well with data obtained in the DRES shock tube, where an 11.7-psi incident overpressure resulted in a closing time of approximately 20 milliseconds.

The strain at the center of the central rib for both blast valves in PRAIRIE FLAT is shown in figure 3.9. It reaches a peak value of about 570 microinches per inch for the lower valve, which corresponds to about 5,700-psi stress--well within the allowable loading for the cast aluminum. No strain measurements were obtained in the DIAL PACK experiment.

Figure 3.10 shows the comparison in rib strains between the field tests and the various shock-tube tests. There is good correlation for all data from the side-on valve orientation. Data from the face-on orientation was obtained in the one-quarter-scale shock-tube tests and shows considerably higher strains for

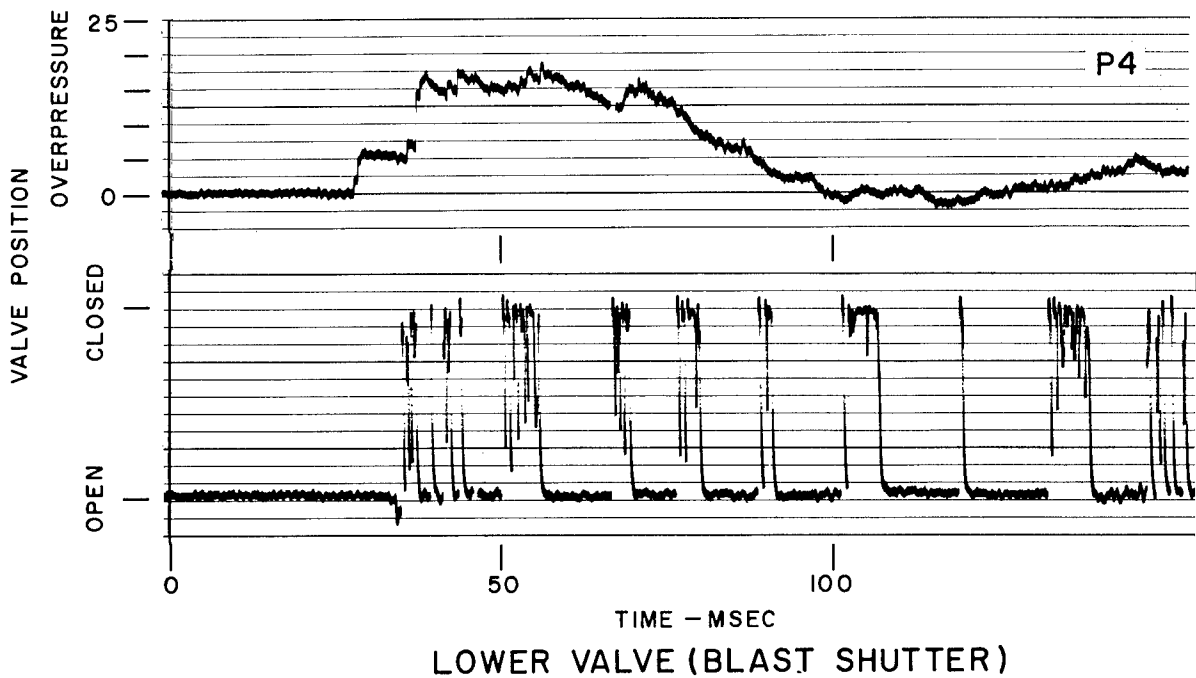
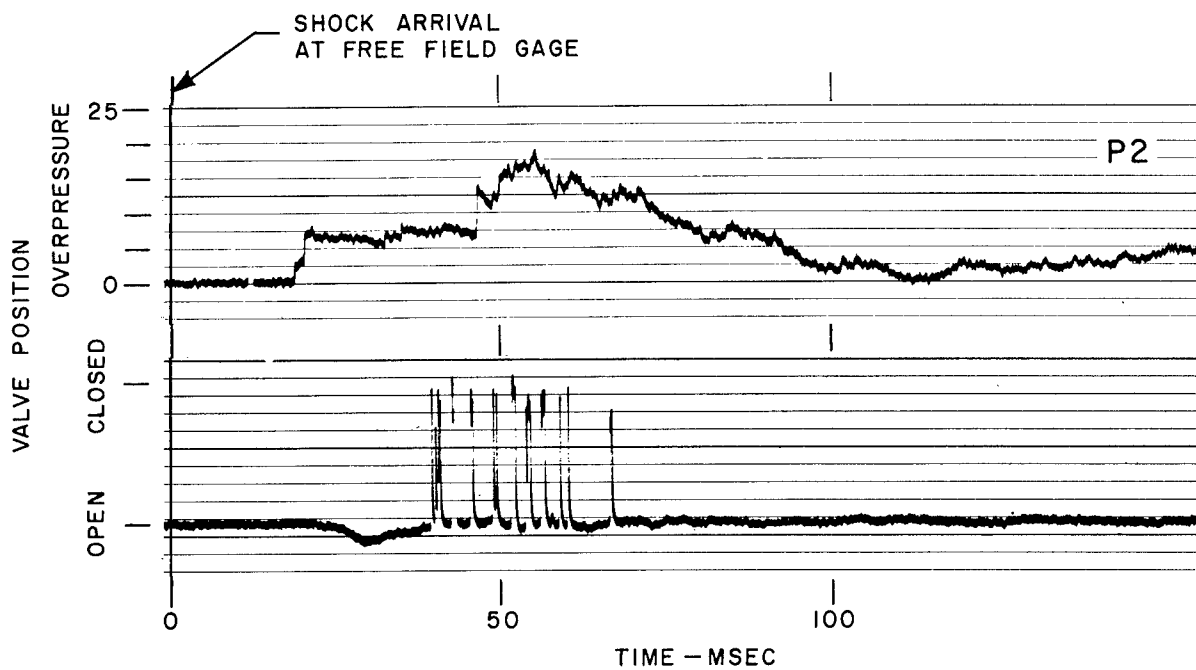

Figure 3.8. --Valve closing times, DIAL PACK Event.

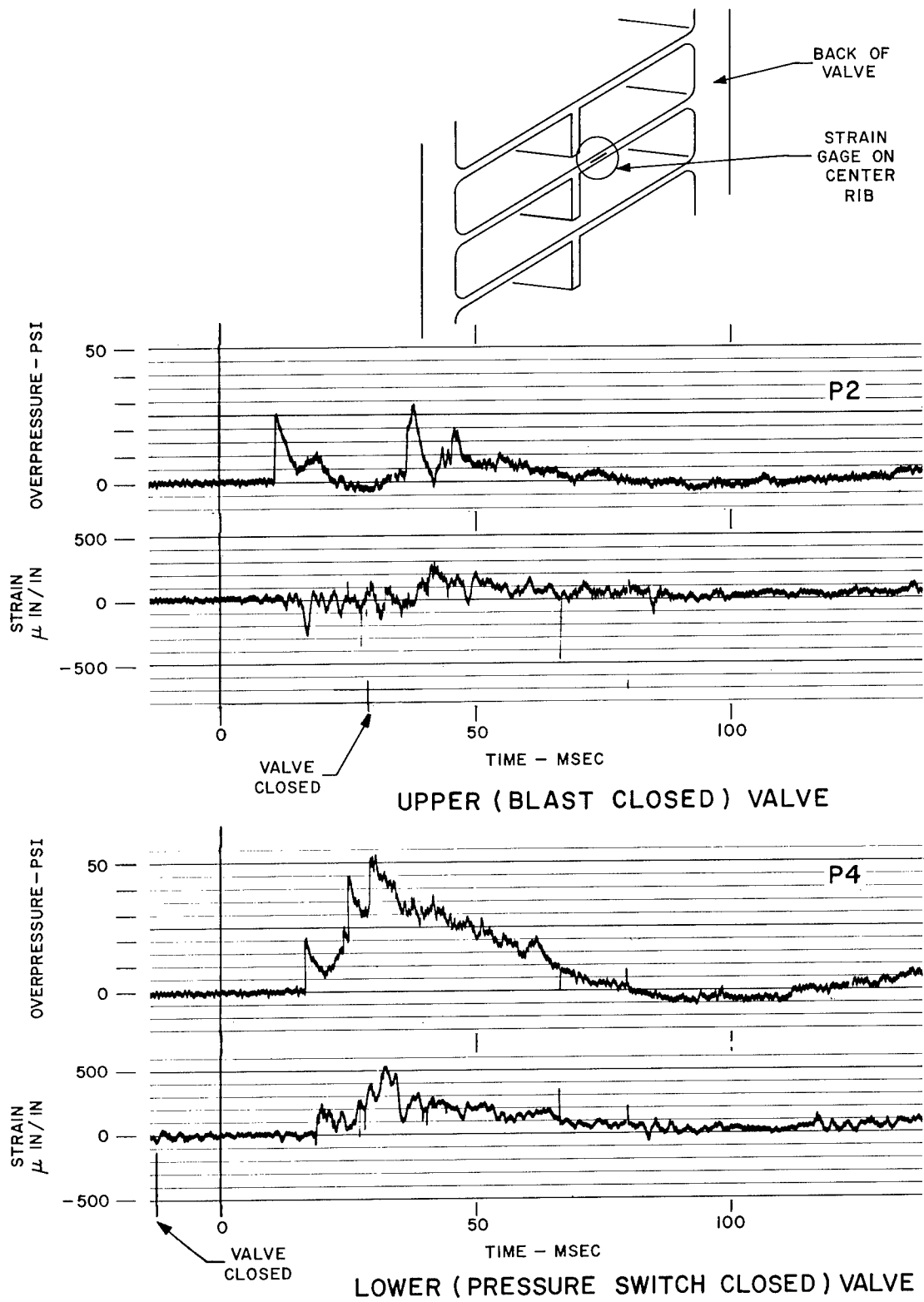

Figure 3.9. --Rib strains in louver valve and air-shaft overpressures at valve locations, PRAIRIE FLAT Event.

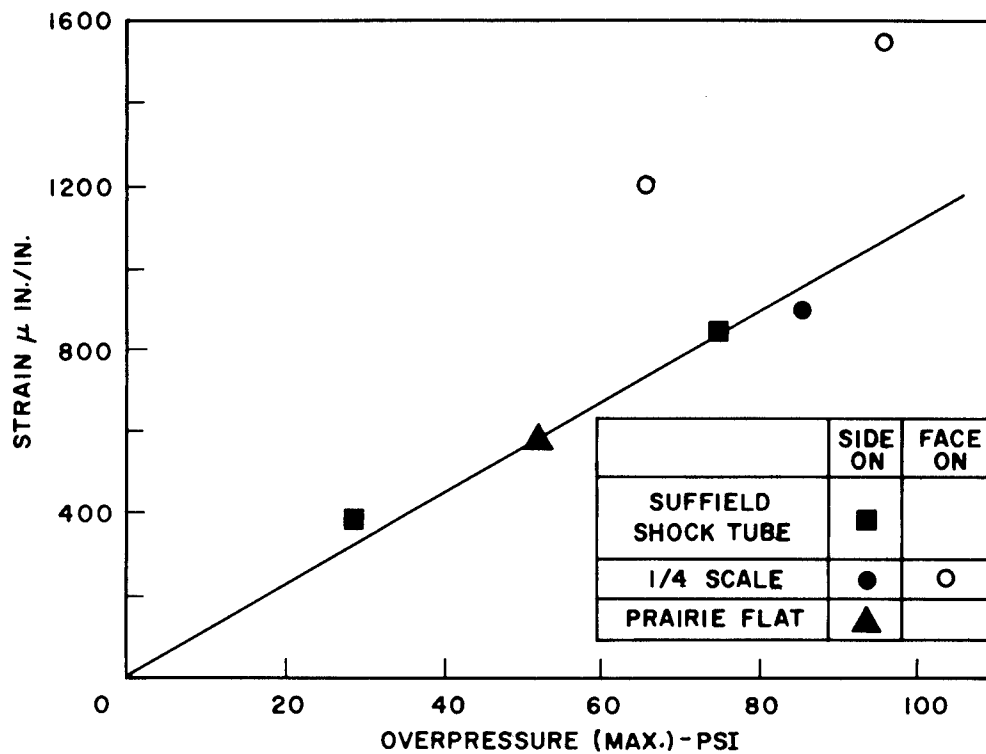

Figure 3.10. --Comparison of peak rib strains in louver valves.

the same peak overpressures. That may be the result of the excitation of different vibrational modes in the blast valve.

### 3.3.2 Blast Shutter.

When the test structure in the DIAL PACK Event was reentered after the shot, the bottom three blades of the blast shutter were found interlocked and had not sprung open as would normally have been expected following the decay of overpressure in the shaft (see figure 3.11). The closing time between pressure arrival at P4 and the activation of the microswitch on the louver valve was about 8.2 milliseconds, as shown in figure 3.8. The intermittent operation of the switch was probably caused by the rebounding of the shutters. After the blast decayed, the center shutter opened, unlike the lower three shutters, and the switch rightly indicated an open valve. The reason for the bottom three shutters being locked closed while the upper ones were free may be that the lower shutters closed faster. The central shutter closed at approximately the same time that the reflected pressure arrived at P4, in line with the central shutter. The bottom shutters may have been closing when the reflected pressure struck them, causing them to close even faster, and resulting in impact damage sufficient to lock the shutters in the closed position.

The shock-tube tests referred to in chapter 1 were also conducted on the blast shutter. Table 3.1 shows how the results compare with field tests. In general, the shutter indentation, bowing, and closing times were nearly duplicated, in spite of the differences in the geometry of the two conditions. In the field tests, the blast shutter was located side-on to the blast, while in the shock tube the blast struck the blast shutter face-on. Also, in the field test there was a confined plenum downstream of the shutter. In the shock-tube test, the area beyond the blast valve was a huge open room.

3.4. PLENUM PRESSURES. The pressure-time records were of primary concern in the DIAL PACK Event and of secondary concern in the PRAIRIE FLAT Event, and, because they were secondary when the test structure was built, only one transducer location was provided in each plenum. Those were the only locations used in the DIAL PACK Event because the instrumentation ports and cable runs employed in the structure were the same in the DIAL PACK Event as in the PRAIRIE FLAT Event.

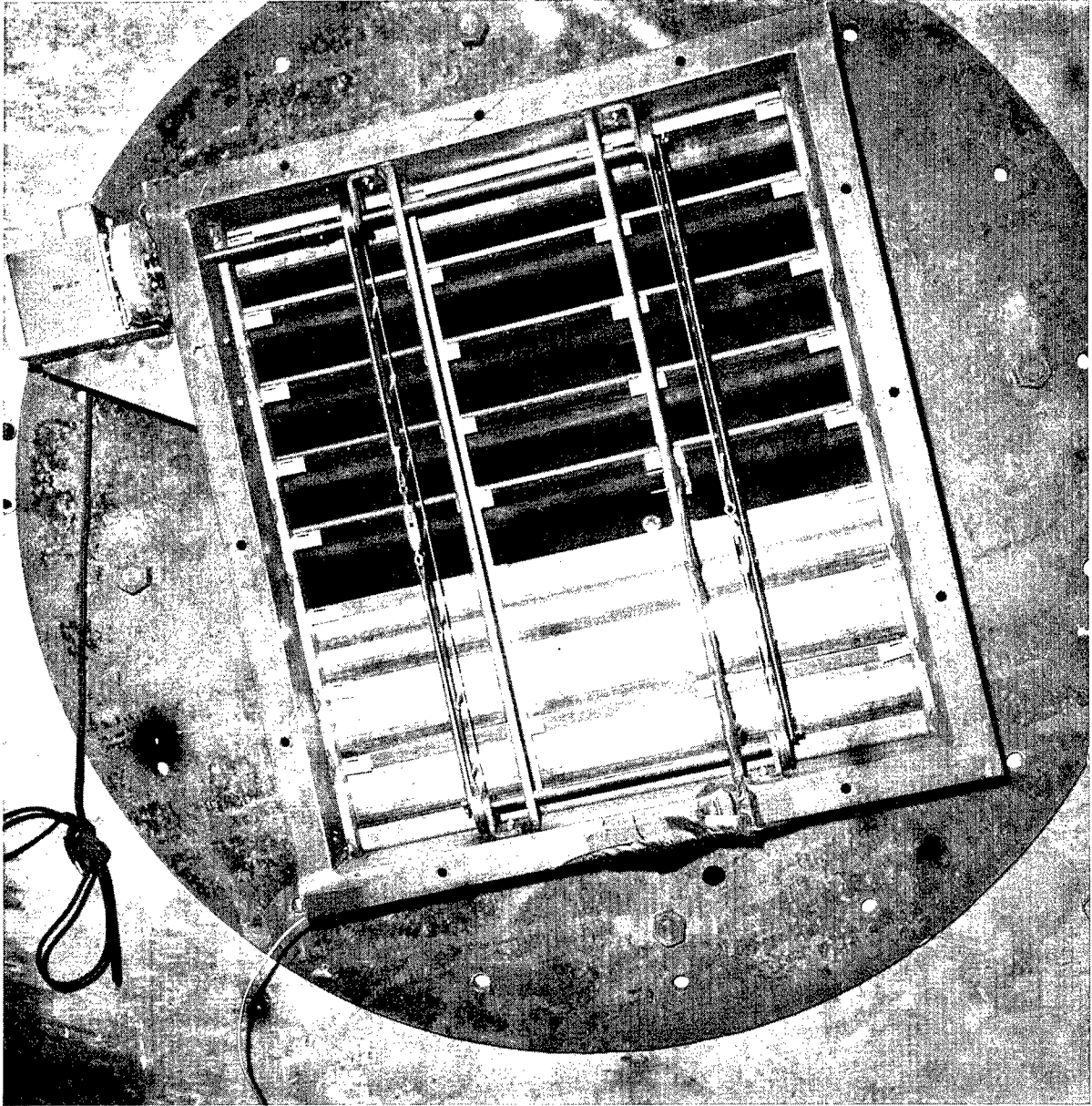

Figure 3. 11. --Blast shutter viewed from plenum chamber,  
postshot, DIAL PACK Event.

TABLE 3.1. --Comparison of shock-tube tests and field tests on blast shutter

Test	Valve Position	Closing Time (msec)	Overpressure		Blade Edge Distortion (in)
			Incident (psi)	Reflected (psi)	
Shock Tube	Open	6	4*	10	0.12
Shock Tube	Closed	—	6.5*	16	0.07
DIAL PACK	Open	8	6	17.5	0.12

## NOTE:

\*Estimated, reflection was immediate.

3.4.1 Waveforms. The pressure-time waveforms observed in these two experiments are shown in figure 3.12. No pressure pulse was observed in the lower plenum in the PRAIRIE FLAT Event, where the valve was closed before blast. In the upper plenum a very jagged history was recorded, with a peak pressure of approximately 7.5 psi. In the DIAL PACK Event the upper plenum had a surprisingly constant pressure-time history, with a peak of approximately 3 psi. In the lower plenum there was a pressure history similar to that recorded in PRAIRIE FLAT but with peak pressures of approximately 1 psi. The second, third, and fourth histories in figure 3.12 are for valves that closed while the blast was acting on them and are of interest here.

#### 3.4.2 Predictions.

Pressure-time predictions have been made based upon the simple model shown in figure 1.12. The model was described in chapter 1 and is repeated here. A compression wave is forced through the blast valve by the overpressure in the air shaft, and that wave traverses the plenum. That is followed by a rarefaction wave which is generated as the blast valve closes. The rarefaction is needed to bring the airflow to rest at the valve when it is closed. A more complete treatment of pressures in chambers can be found in reference 7. The assumed wave distance-time relationship for the upper plenum in PRAIRIE FLAT is shown in figure 3.13. The compression wave was chosen to approximate the observed field data. The rarefaction wave was assumed to end approximately when the blast valve closed. The constructed waveform shows many of the characteristics of the observed waveform, but not all the peaks and valleys in the observed data are predicted by the simple one-dimensional model. That is because there is a more complex wave interaction in the structure, as is shown in figure 1.13 and explained in more detail in reference 7. The expanding wave front interacts with the wall of the plenum and causes reflected waves to form. The reflected waves traverse the plenum from side to side. Durations between the peaks and valleys in the record are in agreement with the shock-traversal time across the 7-foot width of the chamber.

The upper plenum in the DIAL PACK Event gave rise to a very unusual pressure-time record in that it showed an almost constant pressure level. The wave diagram for that plenum, shown in figure 3.14, was constructed in the

GAGE LOCATION

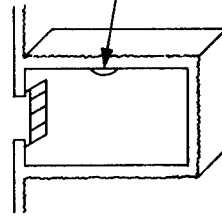

SHOCK ARRIVAL AT  
FREE FIELD GAGE (P1)

SHOCK ARRIVAL  
AT P2

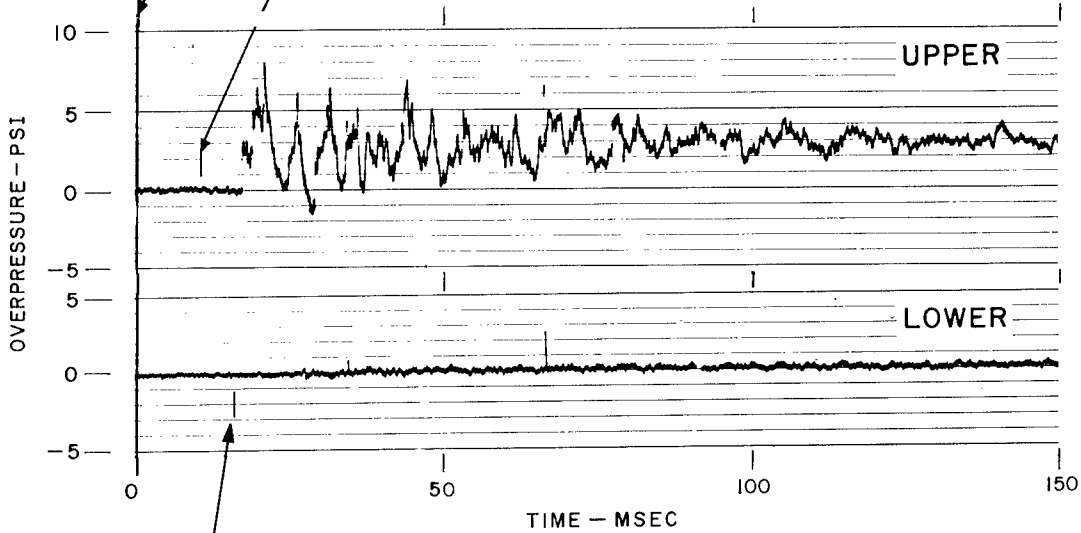

SHOCK ARRIVAL AT P4, P2

PRAIRIE FLAT

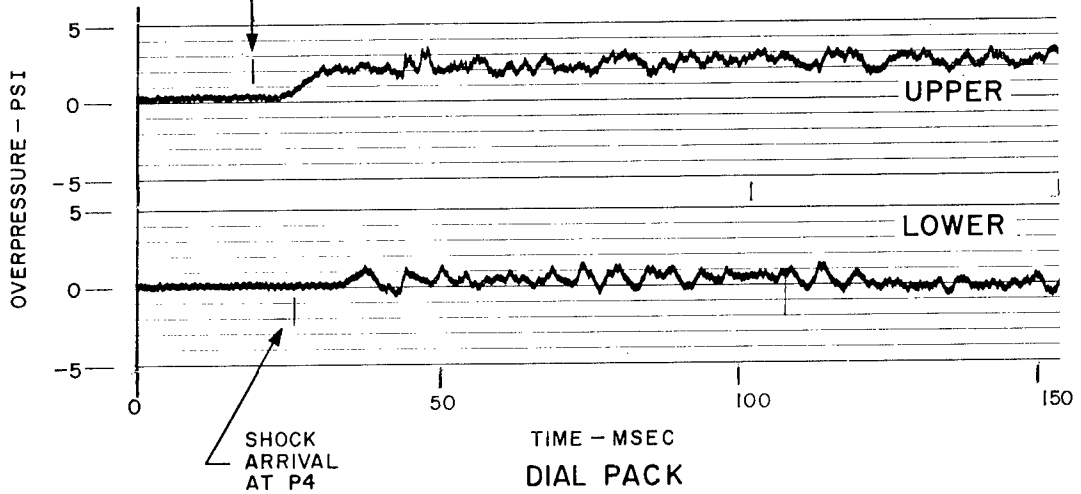

Figure 3.12. --Plenum overpressures.

**GAUGE  
LOCATION**

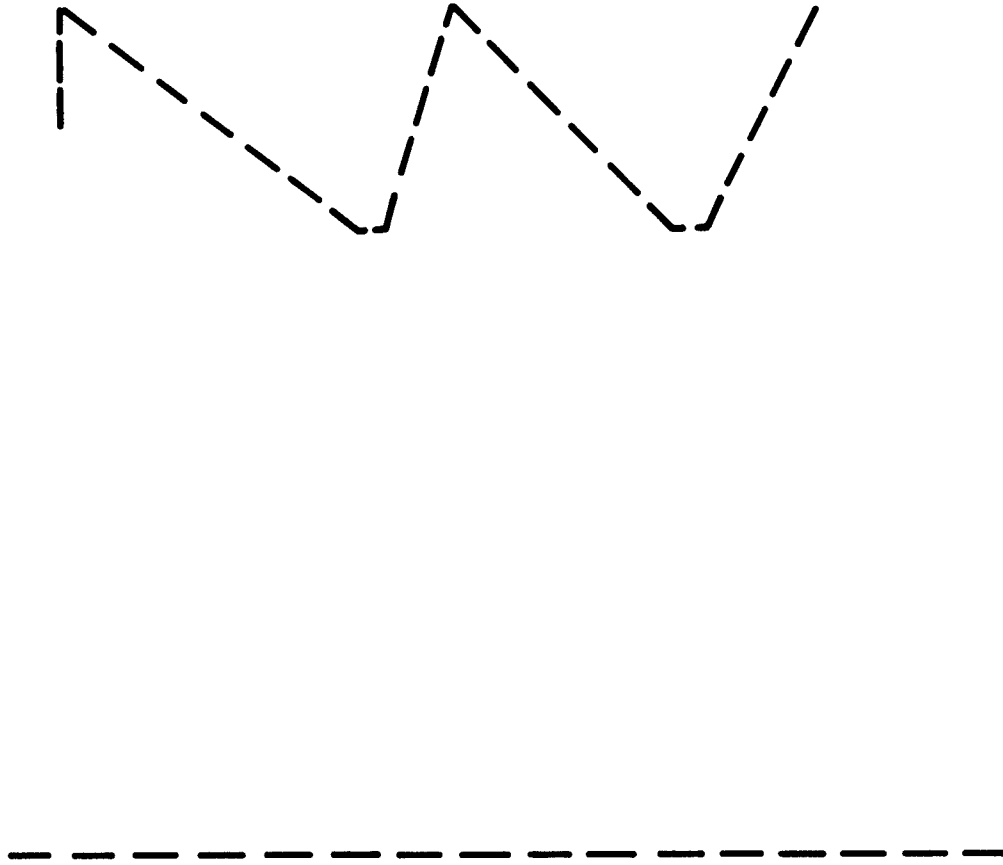

Figure 3.13. --Simplified shock-wave diagram for upper plenum, PRAIRIE FLAT Event.

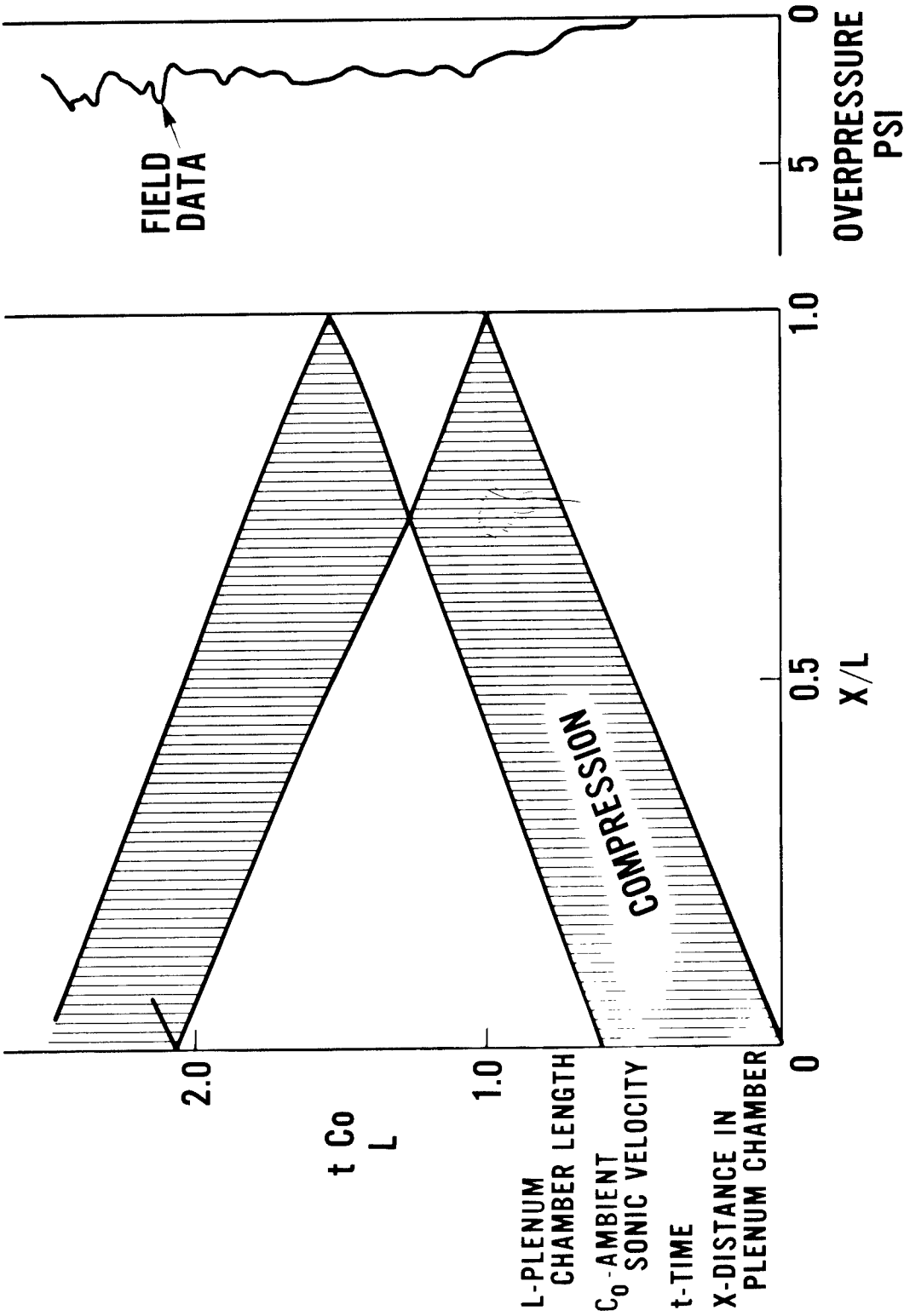

Figure 3.14. --Simplified shock-wave diagram for upper plenum, DIAL PACK Event.

same manner as for figure 3.13. The lower overpressure shocks depicted in figure 3.14 result from the lower free-field overpressures. The time between the compression wave head and the rarefaction wave tail was spread out in figure 3.14 because the valve closed more slowly. Those conditions caused the reflected compression wave and the incident rarefaction wave to merge almost completely at the center of the plenum, where the pressure gage was located. Such waves could tend to cancel each other, and that may very well be the reason that the pressure level in the chamber showed so little fluctuation from a constant level.

The wave diagram for the lower plenum with the blast shutter is shown in figure 3.15, which was also constructed in the same manner as figure 3.13. Most of the primary features of the actual field record are reproduced in the simple wave diagram. However, there are additional peaks between the predicted peaks, which can be attributed to reflections from the walls of the plenum chamber.

Incident pressures are predicted fairly well by the model discussed in chapter 1. The shock wave produced in the valve is that predicted by one-dimensional shock theory, with the compression-chamber pressure being that in the air shaft. The resulting shock wave expands into the chamber, losing strength in the expansion, according to reference 3. The results of applying this model to a variety of shock-tube and field tests are shown in figure 3.16. Two valve areas were used in computing the loss in shock strength from the blast valve to the plenum. One area, that shown in black solid points in the figure, was the minimum area of the blast valve, which takes into account the area taken by ribs, louvers, and other valve elements. The open points in the figure were obtained using the gross open area of the blast valve, the inside rectangular opening. It can be seen that the open points give the best prediction on average, indicating a measured-to-calculated plenum overpressure ratio of about 1.2. The fact that shock wave contraction within the blast valve has little effect on shock strength should not be surprising: when areas decrease shock strengths increase, and when the areas expand shock strengths decrease. That phenomenon was observed in previous shock-tube tests conducted at Bell Laboratories, where pressures through a bellmouth-and-diffuser arrangement were studied. It was found that the area contraction in that device, which acted essentially like a Venturi orifice, had little effect on the shock level propagated through the opening.

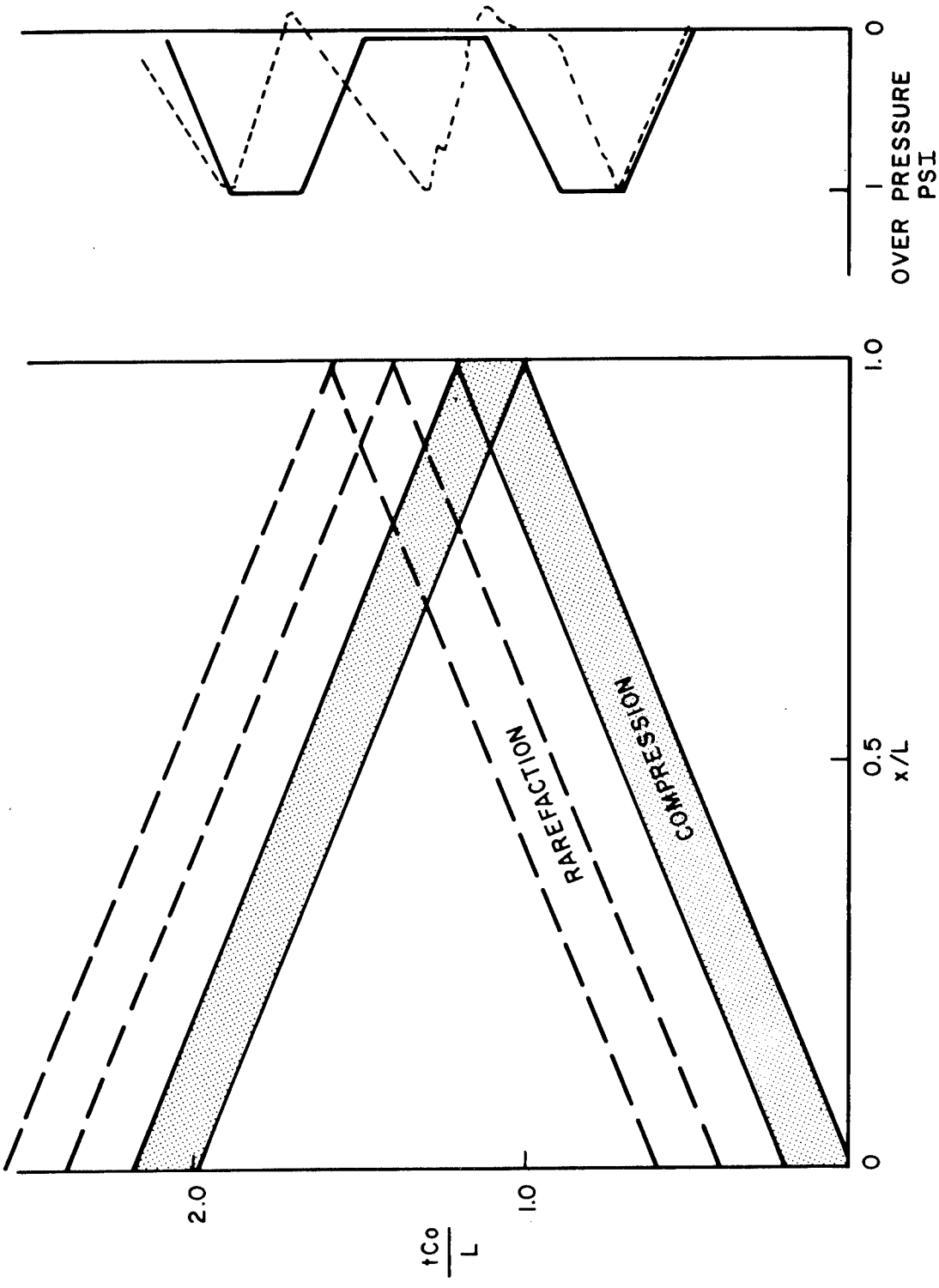

Figure 3.15. --Simplified shock-wave diagram for lower plenum, DIAL PACK Event.

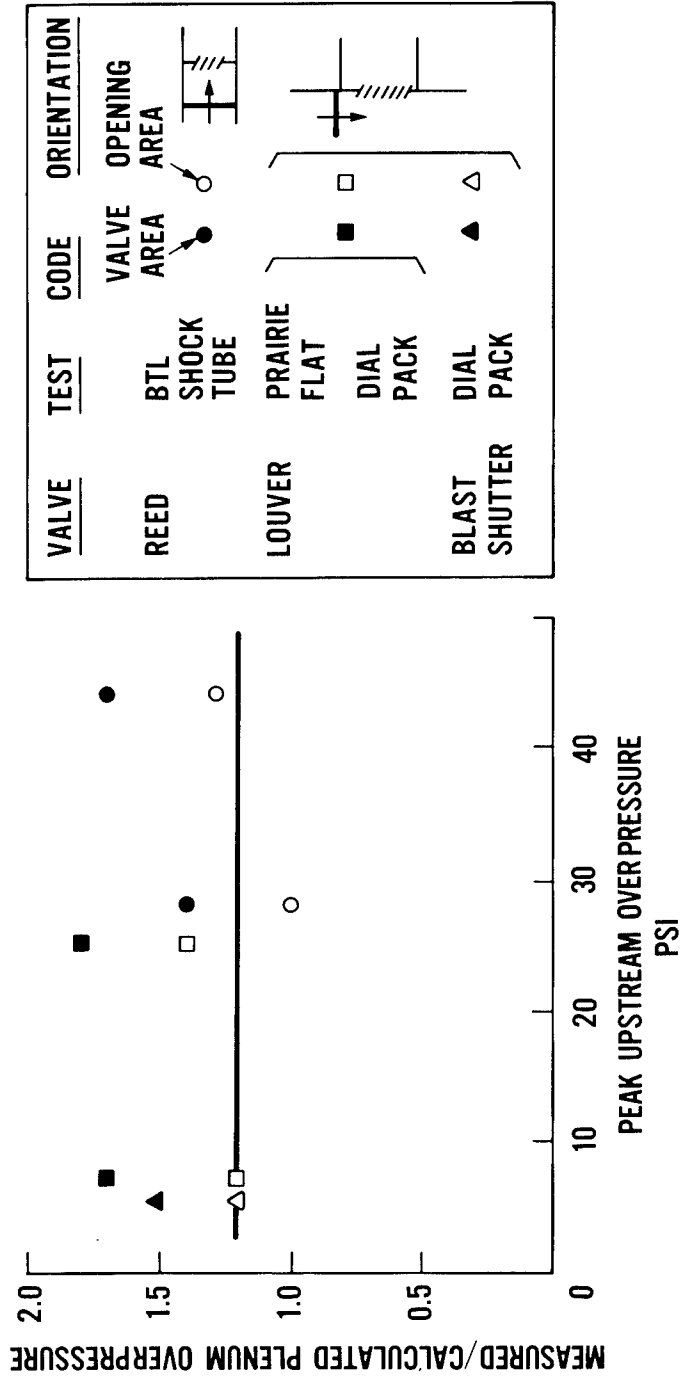

Figure 3.16. --Comparison of measured- and calculated-incident overpressures in plenums.

### 3.5. DUCT DEFORMATION AND DAMAGE.

Sheet-metal ducts, depicted in figure 2.6, were placed in the plenums in the field tests. The ducts provided a simulation of interior equipment that may be found in stations protected by blast valves. In the PRAIRIE FLAT test five ducts made of various gages of galvanized steel sheet were placed in the upper plenum where the louver blast valve was blast closed. A 26-gage duct was placed in the lower plenum. In the DIAL PACK test each plenum had two 26-gage ducts. A summary of the damage incurred by the ducts is presented in figure 3.17. Also, the 18-gage duct at the 6-psi location in the free-field test is shown in the figure. It sustained about the same deformation as a similar duct in the upper plenum.

The following analysis and discussion pertains to 26-gage ducts. Such thin gage ducts in themselves offer very little resistance to overpressure, as was discussed in chapter 1. Their primary resistance to external overpressure comes from a build-up of pressure within the duct as it is deformed by the external pressure. The results of that internal pressure model and the actual field results are shown in figure 3.18. Basic information in figure 3.18 was obtained in static tests. The ducts were loaded with bricks, resulting in various deformations. It should be noted that the primary resistance to deformation of the 2-foot by 6-foot wall of the duct was the stiffness of the center drive joint and not the unreinforced 26-gage sheet metal. The volume change in the duct was computed for each maximum indentation of the duct under the assumption that all sides were similarly indented. Further, it was assumed that the ends of the duct that were held firmly by endcaps did not undergo deformation. The corresponding plenum overpressure for each duct deformation was that pressure which would be reached in the duct by an isentropic compression of the gas trapped in the duct. The data above was used to construct the maximum-deformation curve in figure 3.18. When the static load was removed from the duct a residual deformation remained. That is the important deformation because it was the only observed experimental data. The residual deformation corresponds to the plenum pressure which produced the maximum duct deformation, and that is the basis of the residual-deformation curve in figure 3.18. The data points in the figure were calculated from the static test data.

		DUCT DAMAGE			CONDITION OF END CAPS	
	DUCT GAGE	2 FT X 6 FT FACE (IN.)	1 FT X 6 FT FACE (IN.)			
<u>PRAIRIE FLAT</u>						
UPPER PLENUM						
1	18	2	0			NO DAMAGE
2	26	5	1/2			BLOWN OPEN
3	26	1	2			BLOWN OFF
4	24	2	0			UPPER BLOWN OPEN LOWER BLOWN OFF
5	22	2	0			UPPER BLOWN OPEN LOWER BLOWN OFF
FIELD (6)	19	2	0			NO DAMAGE
<u>DIAL PACK</u>						
UPPER PLENUM (7) 26(2)						
		2	1/2			BLOWN OPEN
LOWER PLENUM						
	26	0	0			NO DAMAGE

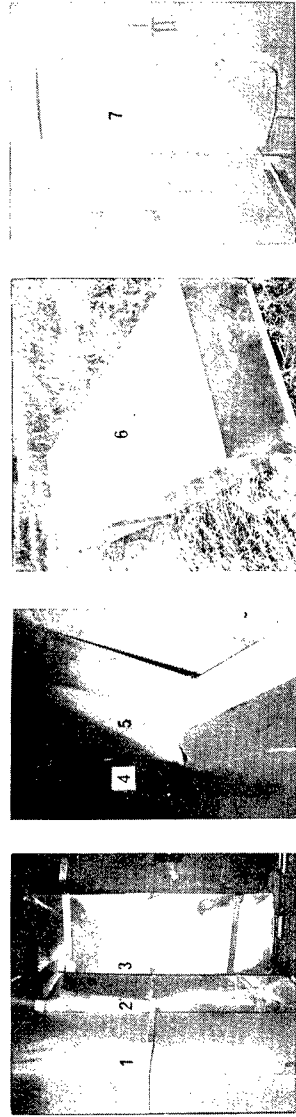

Figure 3.17. --Duct damage in PRAIRIE FLAT and DIAL PACK Events.

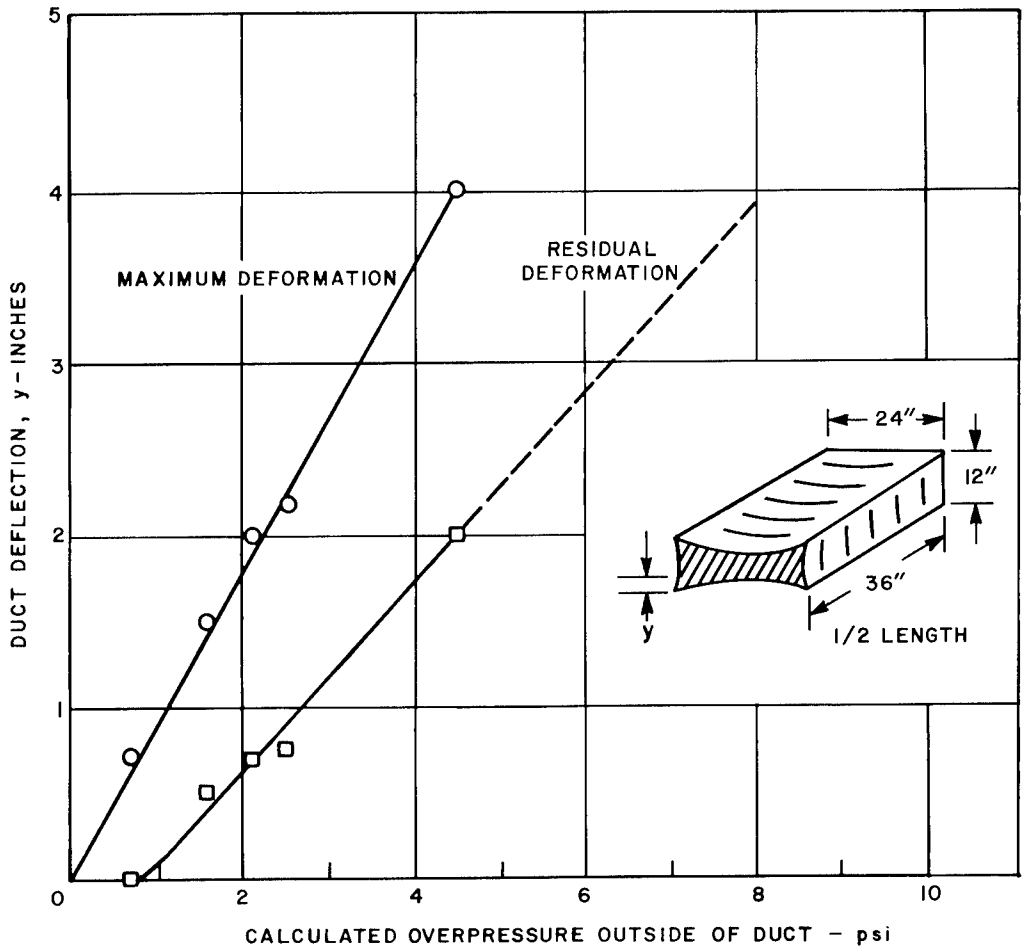

Figure 3. 18. --Duct deformation as a function of external overpressure.

The deformations observed in the field tests are compared with the residual-deformation curve obtained from the model. In the lower plenum at DIAL PACK there was no permanent duct deformation. The peak overpressure was approximately 1 psi, and the model predicts no permanent deformation below 1-psi overpressure. The results here are certainly in accordance with the prediction. In the upper plenum, a peak pressure of 3 psi was observed, and the two ducts were deformed about 2 inches, which agrees with the assumed model. In the PRAIRIE FLAT test, one of the two 26-gage ducts in the upper plenum was deformed 5 inches, and the peak plenum overpressure was 7.5 psi. The model, which extends well beyond the range of the test data, predicts that approximately 10 psi would produce such a deformation. The discrepancy is of little concern because the model is not expected to be accurate for such very large deformations.

### 3.6. OTHER DATA.

Additional data was obtained only in the PRAIRIE FLAT test. Accelerations at locations near the blast valves were recorded, and the acceleration-time records are shown in figure 3.19. The peak vertical acceleration was 8G, and the peak horizontal acceleration was 6G.

Soil-stress gages were placed on the outside wall facing ground zero in the test structure. The pressure-time records are reproduced in figure 3.20. The upper gage at location SS11 indicated an initial peak pressure of about 40 psi, which was approximately the free-field overpressure and a second peak somewhat greater than 50 psi, which may have been due to rebound of the air-shaft wall. The recorded data for the gage at SS10 appears to be faulty.

The soil-stress gages were installed and calibrated by the staff of the Waterways Experiment Station, and the authors are not qualified to discuss further the data from those gages.

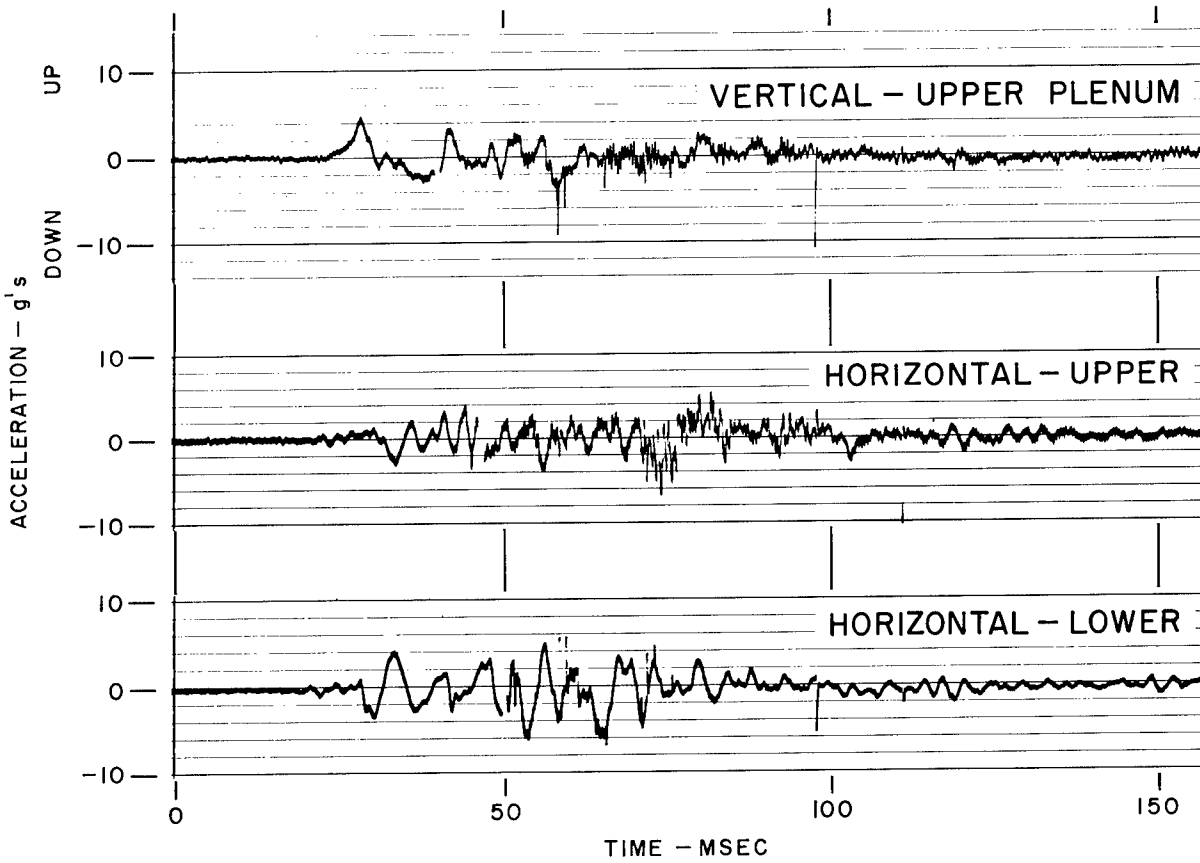
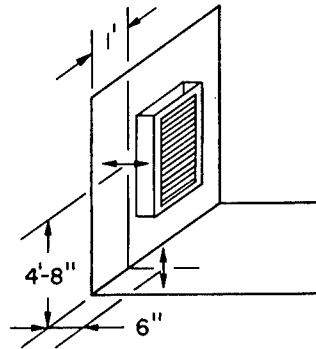

Figure 3.19. --Accelerations near valves, PRAIRIE FLAT Event.

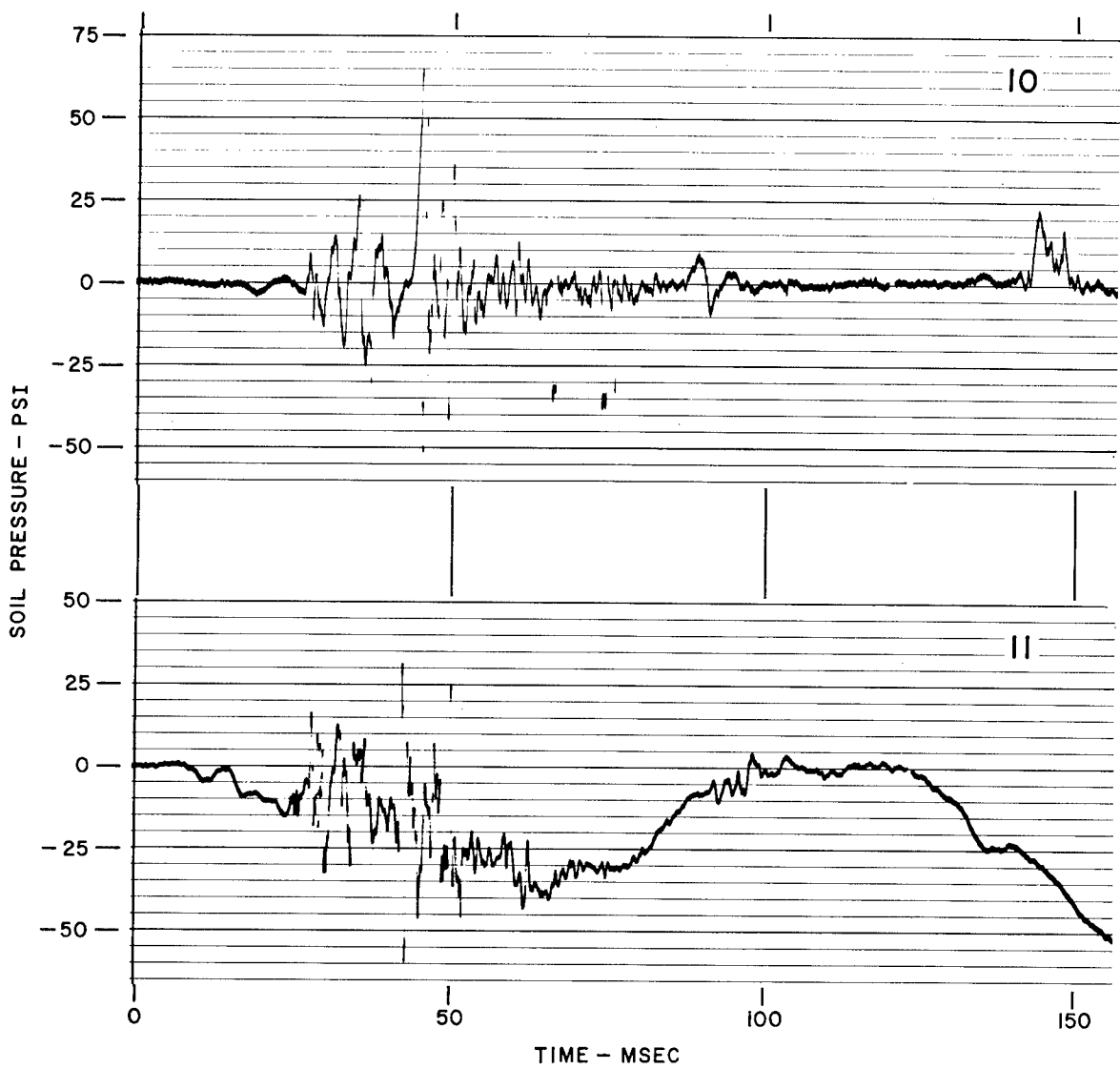
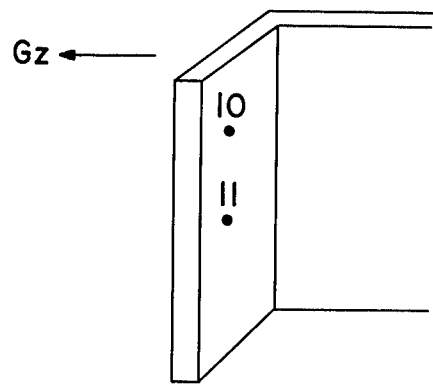

Figure 3.20. --Soil pressures on air-shaft wall, PRAIRIE FLAT Event.

## CHAPTER 4

### CONCLUSIONS AND RECOMMENDATIONS

#### 4.1. AIR-SHAFT OVERPRESSURES.

The overpressures observed in the air shafts in the field experiments compare well with the BRL predictions (reference 7) for longer shafts, where the shock is stabilized into a single front. Since the pressure levels used in the original shock-tube tests on the louver valve were based upon BRL predictions, the results of those tests were applicable to the actual field conditions.

The 1/30-scale shock-tube tests have demonstrated that the actual waveform and peak values in the air shaft can be duplicated and that a shock tube can be used to supplement information from field tests as is needed: additional free-field tests are not required. Also, the similarity between the free-field and shock-tube tests strongly indicates that the waveforms observed in both cases are truly the result of shock interactions in the air shaft and are not in any way influenced by the duration or characteristics of the free-field blast. The same shock pattern should be seen in the blast from a large yield nuclear detonation producing the same peak free-field overpressure.

#### 4.2. VALVE PERFORMANCE.

##### 4.2.1 Louver Valve Subjected to Maximum Pressure.

The point of serious concern in the PRAIRIE FLAT test was that a 34-psi shock, instead of 50 psi, was superimposed on the test structure, which meant that the valves in the structure were subjected to less than the maximum design overpressure. It is, therefore, necessary to extrapolate the results of that test to 50 psi in order to ensure that the valves would have survived at the higher overpressure. A 34-psi free-field blast produces an expected shaft overpressure of 16.5 psi, as predicted from reference 6. That corresponds to dynamic pressure of approximately 6 psi. Predicted values are used here because the dynamic pressure behind the actual complex waveform is not well defined. A 50-psi free-field blast, again using reference 6, results in a transmitted pressure of 22-1/2 psi and roughly a two-fold increase in dynamic pressure. The torque on the blast-valve louvers is assumed to be caused by the blast airflow through the

valve and not by incident overpressure. Further, it is assumed that the effective torque is proportional to the peak dynamic pressure. When the torque is doubled, the blast-valve closing time is divided by the square root of 2. Since the valve closed in 14 milliseconds in the 34-psi blast environment, a 50-psi blast environment should close the valve in about 10 milliseconds. This simple analysis neglects the additional closing torque from the spring, but that supplies an insignificant portion of the energy in blast closing the valve, and it can be safely neglected. A closing time of 10 milliseconds should not damage the valve. One of the tests, run at the Defence Research Establishment's 6-foot shock tube, resulted in a closing time of 8 milliseconds. Valve position versus time is shown in the upper portion of figure 4.1. The valve closed and the basic valve structure was not damaged; however, the actuating mechanism was badly damaged. The louver valve tested in the PRAIRIE FLAT Event had a completely redesigned and strengthened linkage system and actuator, and it is not expected that the 10-millisecond closing time would result in any damage to the blast valve.

The closed valve at the lower location was subjected to a peak reflected overpressure in the shaft of about 50 psi rather than 71 psi expected from a 50-psi free-field overpressure blast. However, a closed valve was not damaged by a peak pressure of 92 psi in one of the tests in the 6-foot shock tube at the Defence Research Establishment, Suffield. The pressure-time record obtained upstream of the valve in another test in the shock tube is shown in the lower part of figure 4.1. This pressure pulse is similar to that recorded upstream of the lower valve in the PRAIRIE FLAT test. The peak overpressure upstream of the upper valve was less than that at the lower location. Figure 3.5 shows that no location in the air shaft would be subjected to a higher peak overpressure than that seen by the lower valve. The pressure record of this location is shown in the right-hand corner of figure 3.5. The maximum strain for 71 psi, calculated from figure 3.10, is about 1,000 micro-inches per inch, or about 10,000 psi, a tolerable stress level. The data for the 92-psi shot is not presented in figure 3.10 because no rib strain records were obtained in that test.

The louver valve, although not tested for 50 psi, shows every evidence of being good for at least the 50-psi free-field overpressure, assuming the valve is mounted in an air shaft. That prediction cannot be extended to other

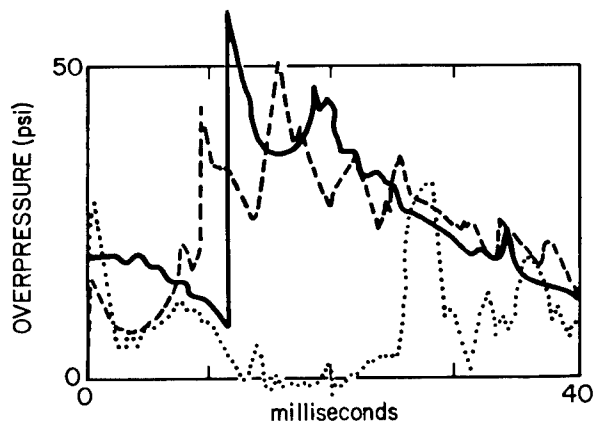
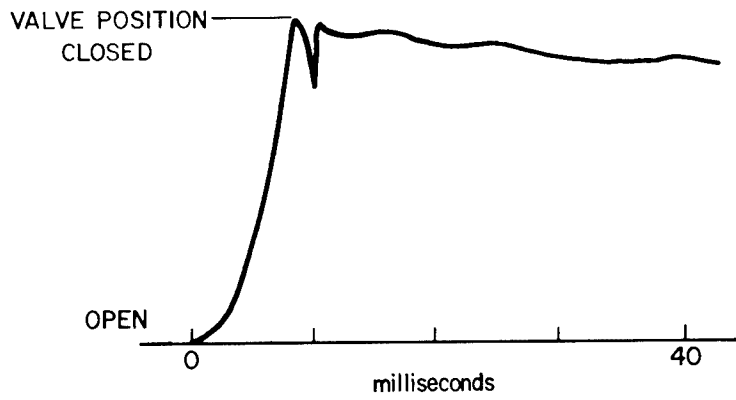

- ..... PRAIRIE FLAT- UPPER
- PRAIRIE FLAT- LOWER
- SUFFIELD TUBE

Figure 4.1. --Overpressure and closing time comparisons.

locations, however. If the valve were to be located above ground level on the side of a building, the overpressures would be much greater--50 psi would reflect to approximately 200 psi in that case.

4.2.2 Louver Valve for Free-Field Overpressure of 12 psi. Since the louver valve withstood much higher overpressure effects, no damage was expected in the 12-psi case and, of course, none occurred. However, the DIAL PACK test did give additional evidence of reliable blast closing of the valve and for an orientation which was different than that in the shock-tube tests.

4.2.3 Blast Shutter. The blast shutter was damaged as predicted using previous shock-tube test data. The shutter worked well once and, after minor redesign making the shutter blades a little longer, the interlocking problem would be eliminated. The valve would then spring completely open for the free passage of air.

4.3. PLENUM PRESSURES. Data obtained in these experiments is consistent in that both the incident pressure and the waveform can be reasonably predicted by simple models. Those models can be used to predict other plenum pressure conditions for different valve closing times, valve areas, and overpressures acting on the valves. The effect of pressure pulses on ducts is also predictable. Resistance of thin sheet-metal ducts comes primarily from the air within being compressed: this is independent of duct orientation. In the test, the ducts were almost instantly engulfed by the blast. If the duct had been running in the direction of the blast, it would have been engulfed as the shock wave traveled along the duct. The pressure inside the duct would correspond to the outside pressure because the buildup of internal pressure would propagate as a compression or shock wave and would not fill up the duct immediately.

4.4. BLAST PROTECTION AFFORDED BY THE BLAST VALVES. Very useful conclusions can be drawn from the test results, with regard to the blast protection afforded by actual AT&T communication buildings.

4.4.1 Buildings Designed to Withstand a Free-Field Overpressure of 50 psi. Here, the evidence was obvious that the blast-closing louver valve allowed considerable damage to the lighter gage ducts. It can be assumed that other interior equipment in the station would be severely damaged. The other valve closed as predicted, and the tests showed that the control systems and pressure switches

all functioned correctly. The leakage through the valve was not sufficient to cause any significant pressure rise in the plenum. That is an important factor because the valve is not designed to give a tight closure, since all closing surfaces are metal to metal, and no gaskets are provided.

#### 4.4.2 Stations Designed to Withstand a Free-Field Overpressure of 10 psi.

Results for the 12-psi tests are, of course, applicable to the 10-psi stations with about the same ratio of valve area to plenum area. The louver valve closed in approximately 20 milliseconds, allowing a pulse with a peak pressure of about 3 psi into the plenum. Damage to ducts would be minor and filters probably would not be affected at all by the pressure in such a case. It appears that the blast closing of the louver valve affords reasonable protection for a 10-psi building. The blast shutter closed more rapidly and allowed only about a 1-psi peak pressure into the plenum. No damage to the ducts inside the plenums was measured. A 1-psi overpressure blast will not cause any serious personnel injuries nor damage any equipment used in the protected buildings. In brief, the blast closing shutter provided complete protection from the 10-psi blast environment. Also, there was no evidence of any negative phase damage on the air ducts. For a nuclear explosion, the peak negative-phase pressure would be about 2 psi. If the duration were long enough, the plenum would experience a 2-psi underpressure. That could cause some duct bulging, but the slow decrease in pressure would probably keep most pressure differentials low. The blast shutter has about one-half the area of the louver valve, and that is a factor in plenum pressure. Had the blast shutter the same cross-sectional area as the louver valve, the incident overpressure would probably have been about 2 psi, and that could cause minor duct indentation.

## REFERENCES

1. Watson, J. S. "Evaluation of Louver Blast Valve." Suffield Memorandum No. 89/68, Defence Research Establishment, Suffield; Ralston, Alberta, Canada, September 1968. Unclassified.
2. McCoy, R. G., Nevrincean, G., and Witt, E. F. "Prediction of Blast Valve Response Using Models." Bell Telephone Laboratories. Reprinted from The Shock and Vibration Bulletin, No. 40, Part 2, The Shock and Vibration Information Center, Naval Research Laboratory, Washington, D.C., December 1969. Unclassified.
3. Chisnell, R. F. "The Motion of a Shock Wave in a Channel with Applications to Cylindrical and Spherical Shock Waves." Journal of Fluid Mechanics, Vol. 2, page 286, 21 January 1957. Unclassified.
4. Ross, R. R. "Blast Valves for Hardened Installations." Symposium Proceedings Operation SNOWBALL, Defense Atomic Support Agency 1642-1, DASA Center, General Electric Co., TEMPO, Santa Barbara, California, August 1965. Unclassified.
5. Eaves, W. B. "A Small Portable Field Data-Recording Instrumentation Package." Bell Telephone Laboratories, Whippany, New Jersey. Reprinted in Instrumentation for Nuclear Weapon Effects Simulation Symposium, Vol. IV, page 385, Air Force Special Weapons Center, Kirtland Air Force Base, New Mexico, March 1970. Unclassified.
6. Shock-Tube Facilities Staff. "Information Summary of Blast Patterns in Tunnels and Chambers." Second Edition, DASA Report No. 1273, Ballistic Research Laboratories, Memorandum Report No. 1390, pages 3-11, Aberdeen Proving Ground, Maryland, March 1962. Unclassified.
7. Coulter, G. A. "Flow in Model Rooms Caused by Air Shock Waves." Ballistic Research Laboratories, Memorandum Report No. 2044, Aberdeen Proving Ground, Maryland, July 1970. Unclassified.
- A.1. Roark, R. J. "Formulas for Stress and Strain." Fourth Edition, pages 226 and 227, McGraw Hill Book Co., New York, New York, 1965. Unclassified.

REFERENCES (Continued)

- A.2. Leissa, A. W. "Vibration of Plates." Science and Technology Information Division, National Aeronautics and Space Administration, Washington, D.C., 1969. Unclassified.
- A.3. Biggs, J. M. "Introduction to Structural Dynamics," page 74, McGraw Hill Book Co., New York, New York, 1964. Unclassified.

## APPENDIX

### INDENTATION OF AIR DUCTS BY PRESSURE PULSES

#### A. 1. STATIC DEFORMATION OF DUCT WALLS.

For a plate with fixed edges (reference A. 1)

	<u>a/b</u>	<u>α</u>	<u>β</u>
$y_{\max} = \alpha \frac{pb^4}{Eh^3}$	1	0.014	0.31
	1.4	0.023	0.44
$\sigma_{\max} = \beta \frac{pb^2}{h^2}$	2	0.028	0.50
	∞	0.028	0.50.

The pressure ( $p_e$ ) needed to stress the duct wall to the yield point ( $\sigma_e$ ) assuming that  $\sigma_e$  is 60,000 psi is:

$$p_e = \frac{h^2}{\beta b^2} 60,000.$$

For a duct wall made of 26-gage sheet steel ( $h = 0.018$  in.):

$$p_e = \frac{19.4}{\beta b^2},$$

and the deformation for this load is:

$$y_e = \frac{\alpha b^4 p_e}{174}.$$

Values of  $p_e$  and  $y_e$  are tabulated in table A. 1. The two values of (a) represent the entire length of the duct (72 inches) and one-half that value. The length of the duct was divided in two by a center seam. The actual properties of the duct wall with a center seam should be bounded by the two cases, (a) = 36 inches and (a) = 72 inches. There is little difference in  $p_e$  and  $y_e$  as a result of this change in (a). The two values of (b), 12 inches and 24 inches, represent the narrower and wider faces of the duct, respectively. The wider face is more vulnerable to indentation, and only the 24-inch and 72-inch wall sizes will be considered in the

following calculations. The values of  $p_e$  and  $y_e$  for different gage walls of the same length and width are calculated as follows from the values obtained for the 26-gage walls:

$$p_e \text{ (x-Gage)} = p_e \text{ (26-Gage)} \left( \frac{h_x}{0.018} \right)^2$$

$$y_e \text{ (x-Gage)} = y_e \text{ (26-Gage)} \frac{0.018}{h_x} .$$

Results for duct walls of 18-, 22-, 24-, and 26-gage are presented in table A.2.

#### A.2. NATURAL FREQUENCY OF DUCT WALLS.

Natural frequency of a plate with all edges fixed is:

$$\omega = \frac{\pi^2 h}{a^2} \sqrt{\frac{E}{12(1-\eta^2)} \frac{K}{\rho N}} \quad N = 2.25$$

$$K = 12 + 8 \left( \frac{a}{b} \right) + 12 \left( \frac{a}{b} \right)^2$$

for  $a = \rho$  ft

$b = 2$  ft

$E = 4.32 \times 10^9$  psf

(From reference A.2)

$\rho = 15.2$  slugs/foot<sup>3</sup>

$\omega = 2.5 h$  (inch)  $\times 10^3$  rad/sec

$\eta = 0.3$ .

The natural frequencies and periods for plates of various gages are presented in table A.2.

#### A.3. DYNAMIC RESPONSE OF DUCT WALLS TO SHORT DURATION PULSES.

Reference A.3 contains graphs which give the maximum deformation of an oscillator with an elastic-plastic resistance characteristic as a function of the magnitude and duration of the applied load. In this case, the appropriate load had an instantaneous rise to a peak value and linear decay to zero in time  $\tau$ . Table A.3 contains selected data from the appropriate graph in reference A.3. The parameters used in reference A.3 are dimensionless. The pulse duration  $\tau$  is divided by the natural period of the member,  $T$ . The loading function is

TABLE A. 1. --Pressures and deformations at yield stages

b (in)	a (in)	a/b	$p_e$ (psi)	$y_e$ (in)
12	36	3.0	0.27	0.90
12	72	6.0	0.27	0.90
24	36	1.5	0.77	3.4
24	72	3.0	0.68	3.6

TABLE A. 2. -- $p_e$  and  $y_e$  for various gage plates

Gage	h (in)	$p_e$ (psi)	$y_e$ (in)	w (rad/sec)	T (sec)
26	0.018	0.068	3.6	45	0.14
24	0.022	0.10	2.9	55	0.11
22	0.028	0.16	2.3	70	0.09
18	0.049	0.50	1.3	120	0.05

TABLE A. 3. --Elastic-plastic deformations of 2-foot by 6-foot duct wall

Gage $\tau$ (sec)	p = 0.5 psi			p = 1.0 psi			p = 2.0 psi			p = 5.0 psi			
	26	24	18	24	22	18	24	22	18	22	18	22	18
	0.14	0.20	0.32	0.10	0.16	0.50	0.08	0.25	0.10				
$\tau/T$	0.36	0.45	0.55	1.0	0.45	0.55	1.0	0.55	1.0	0.55	1.0	0.55	1.0
$y/y_e$	30	20	11	1.9	80	42	10	150	60	400	400	400	400
y (in)	110	58	25	2.5	230	97	13	340	78	520	520	520	520
$\tau/T$	0.14	0.18	0.22	0.40	0.18	0.22	0.40	0.22	0.40	0.22	0.40	0.22	0.40
$y/y_e$	5.5	4.0	2.5	1.0	15	8.0	2.8	30	10	70	70	70	70
y (in)	20	12	5.7	1.3	43	18	3.6	69	13	91	91	91	91
$\tau/T$	0.07	0.09	0.11	0.20	0.09	0.11	0.20	0.11	0.20	0.11	0.20	0.11	0.20
$y/y_e$	1.5	1.3	1.0	0.7	4.0	2.4	1.2	7.5	3.0	18	18	18	18
y (in)	5.4	3.8	2.3	0.9	12	5.5	1.6	17	3.9	23	23	23	23
$\tau/T$	0.04	0.05	0.06	0.10	0.05	0.06	0.10	0.06	0.10	0.06	0.10	0.06	0.10
$y/y_e$	0.80	0.70	0.50	0.32	1.5	1.0	0.6	2.3	1.2	5.0	5.0	5.0	5.0
y (in)	3.0	2.0	1.0	0.40	4.3	2.3	0.8	5.3	1.6	6.5	6.5	6.5	6.5

defined as that just causing plastic behavior divided by the peak applied load, here  $p_e/p$ .

The displacement function is the maximum dynamic displacement of the member divided by the displacement at which plastic behavior first occurs. In the symbols used here this is  $y/y_e$ .

#### A. 4. EXPERIMENTAL DETERMINATION OF DUCT INDENTATION.

A 1-foot by 2-foot by 6-foot 26-gage duct, similar to those tested in the field, was loaded to obtain experimental information on duct deformation. One 2-foot by 6-foot side was loaded with bricks to produce a range of effective pressure. The bricks were stacked so that they did not support each other but approximated a uniform load over the face of the duct. Deformation measurements were taken along the central seam of the loaded face. The measurements were taken with the load on the duct and after the load was removed to give residual deformation. Experimental data is presented in table A. 4.

The loading of all sides of the duct simultaneously would tend to produce fixed conditions at the edges. That edge constraint was assumed in the previous analysis. In this case, loading was only applied to one face of the duct. However, the sidewalls were clamped between boards to keep them from being bent by the loaded wall. This partially compensated for the lack of loading on the other three walls of the duct. This artificially imposed rigidity may have been responsible for membrane stresses in the wall, which reduced deformations--an effect which is ignored in these tests.

#### A. 5. VOLUME CHANGE AND PRESSURE RISE RESULTING FROM DUCT INDENTATION.

The area between the initial and deformed center seam line of the duct is:

$$\frac{\Delta A}{s_1 s_2} = \frac{1}{4s_2} (y_{1/4} + y_{1/2} + y_{3/4}).$$

The change in duct cross section taken through the center seam is:

$$\frac{\Delta A_T}{s_1 s_2} = -\frac{2\Delta A}{s_1^2 s_2} - \frac{2\Delta A}{s_1 s_2} \left(\frac{s_2}{s_1}\right)^5.$$

The second term accounts for deformation of the narrower sides. Elastic deformation of a plate varies as a width to the 4th power. Therefore, the change in area for this side would be the change in area for the larger side times the width ratio to the 5th power, assuming that the deformation curves are similar. In this case,  $s_1$  is 24 inches and  $s_2$  is 12 inches, and:

$$\frac{\Delta A_T}{s_1 s_2} = 2.06 \frac{\Delta A}{s_1 s_2} .$$

Since the ends of the duct are fixed by caps, the change in volume of the duct is assumed to be one-half the change in area at the central cross section. This change in volume can be related to an internal pressure increase  $\Delta p$ , assuming isentropic compression. For small changes in pressure the following relation is approximately true:

$$\frac{\Delta p}{p} = 1.4 \frac{\Delta V}{V} = 0.7 \frac{\Delta A_T}{s_1 s_2} .$$

The above described area, volume, and pressure changes are listed in table A.5 for various duct deformations. The experimentally determined deformations were the basis for these calculations. The relation between duct deformation and pressure rise is shown in figure A.1. It is assumed that these relationships hold regardless of the thickness of the duct walls. This only requires that the same maximum duct indentation produces the same volume change in the duct.

#### A.6. COMBINED EFFECTS OF INTERNAL PRESSURE AND DYNAMIC RESPONSE OF DUCT WALLS.

The pulse pressure required to produce a given duct indentation is the sum of the pressure required to deform the duct wall (paragraph A.3) and the increase in internal pressure (paragraph A.5) which resists an equal external pressure. The internal pressure obtained from static data is here applied to a dynamic case. This is reasonable, because the deformation of the duct, not the duration of the loading pulse, controls the internal pressure. The external pressures, which cause deformations of 5 inches, 2 inches, and 1 inch, are given in figure A.1. The parameters are duct wall thickness and duration of the pressure pulse.

TABLE A. 4. --Duct deformation

Number of Bricks on Duct	Equivalent Pressure psi	Deformation (in)* Position Across 2 foot Dimension				
		1/4	Approx 1/3	1/2	Approx 2/3	3/4
0	0	0		0		0
18	0.06	0.40		0.70		0.50
0	0	0		0		0
36	0.12	1.00		1.50		1.00
0	0	0.30		0.50		0.30
54	0.18	1.25		2.0		1.35
0	0	0.35		0.70		0.45
72	0.25	1.40		2.20		1.50
0	0	0.40		0.75		0.50
144	0.50		3.60	4.0 Est	3.80	
0	0	1.30	1.75	2.00	1.35	1.40

\*On 2' x 6' face.

TABLE A. 5. --Area, volume, and pressure changes

Maximum Center Seam Deflection y (in)	$\Delta A/A$	$\Delta A_T/A$	$\Delta V/V$	$\Delta p/p$	$\Delta p$ psi $p_0 = 13.6$	$\Delta p$ psi $p_0 = 14.7$
0	0	0	0	0	0	0
0.7	0.033	0.068	0.034	0.047	0.64	0.69
1.5	0.073	0.15	0.08	0.11	1.5	1.6
2.0	0.097	0.20	0.10	0.14	1.9	2.1
2.2	0.11	0.23	0.12	0.17	2.3	2.5
4.0	0.21	0.43	0.22	0.31	4.2	4.5

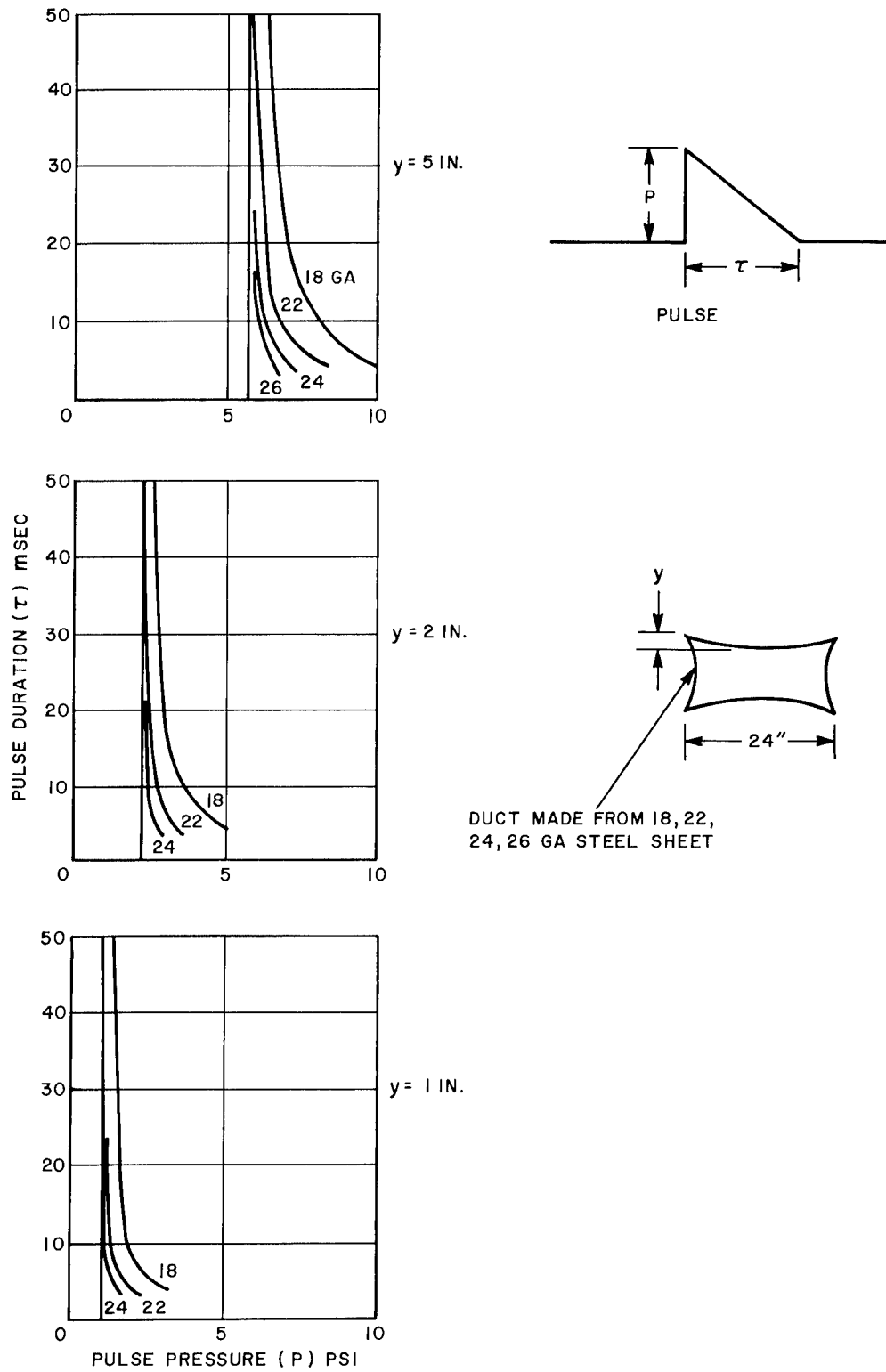

Figure A. 1. --Elastic-plastic duct wall deformation, considering internal pressure buildup.

## LIST OF SYMBOLS

A	Cross-sectional area of duct
$\Delta A$	Area between center seam line of initial duct and deformed duct
$A_T$	Change in cross-sectional area of duct
a	Length of plate
b	Width of plate
E	Young's modulus (modulus of elasticity)
h	Plate or sheet thickness
p	Pressure
$\Delta p$	Internal pressure change
$p_e$	Static pressure which produces $\sigma_{\max} = \sigma_e$
$p_o$	Ambient pressure
$s_1$	Width of duct
$s_2$	Depth of duct
T	Natural period of plate
V	Volume
$\Delta V$	Volume change
$y_{\max}$	Deformation of plate at center
$y_e$	$y_{\max}$ with a static pressure of $p_e$
$\nu$	Poisson's ratio
$\rho$	Mass density of material (steel in this case)
w	Natural frequency of plate (rad/sec)
$\sigma_{\max}$	Maximum loading stress in plate
$\sigma_e$	Yield strength of duct material
$\tau$	Period of pressure pulse
$\alpha$	$y_{\max} = \alpha \frac{pb^4}{Eh^3}$
$\beta$	$\sigma_{\max} = \beta \frac{pb^2}{T^2}$
$\eta$	Poisson's ratio

THIS PAGE IS INTENTIONALLY LEFT BLANK.

DISTRIBUTION LIST

COPIES

DEPARTMENT OF DEFENSE

- 12 DEFENSE DOCUMENTATION CENTER, CAMERON STATION,  
ALEXANDRIA, VIRGINIA 22314  
ATTN: TC
- 1 DIRECTOR, DEFENSE INTELLIGENCE AGENCY, WASHINGTON,  
D.C. 20301  
ATTN: DI-7B, PHYS. VUL. DIV., MR. FRANK DEEDS
- 22 DIRECTOR, DEFENSE NUCLEAR AGENCY, WASHINGTON, D.C.  
20305  
ATTN: DDST  
ATTN: APSI (ARCHIVES)  
ATTN: SPLN, MR. JACK R. KELSO  
ATTN: APTL, TECHNICAL LIBRARY (2 CYS)  
ATTN: MAJOR WILLIAM J. SHEPARD (15 CYS)  
ATTN: SPAS  
ATTN: SPSS
- 1 DEPARTMENT OF DEFENSE EXPLOSIVES SAFETY BOARD,  
RM-GB270, FORRESTAL BUILDING, WASHINGTON, D.C. 20301  
ATTN: MR. RUSSEL G. PERKINS
- 2 COMMANDER, FIELD COMMAND, DEFENSE NUCLEAR AGENCY,  
KIRTLAND AFB, NEW MEXICO 87115  
ATTN: TECHNICAL LIBRARY, FCTA-A  
ATTN: FCTD-T
- 1 CHIEF, LIVERMORE DIVISION, FIELD COMMAND, DNA,  
LAWRENCE LIVERMORE LABORATORY, P.O. BOX 808,  
LIVERMORE, CALIFORNIA 94550  
ATTN: FCTA-D
- 1 DIRECTOR, WEAPONS SYSTEMS EVALUATION GROUP, ODDR&E,  
OFFICE, SECRETARY OF DEFENSE, 400 ARMY-NAVY DRIVE,  
WASHINGTON, D.C. 20305  
ATTN: CAPT DONALD E. MCCOY, USN

DEPARTMENT OF THE ARMY

- 1 COMMANDING OFFICER, ABERDEEN PROVING GROUND,  
ABERDEEN PROVING GROUND, MARYLAND 21005  
ATTN: TECHNICAL LIBRARY

COPIES

DEPARTMENT OF THE ARMY (CONTINUED)

- 8 COMMANDING OFFICER, ABERDEEN RESEARCH AND DEVELOPMENT CENTER, ABERDEEN PROVING GROUND, MARYLAND 21005  
ATTN: MR. R. N. SCHUMACHER  
ATTN: MR. R. E. REISLER  
ATTN: MR. R. P. LONG  
ATTN: MR. J. H. KEEFER  
ATTN: MR. L. GIGLIO-TOS  
ATTN: MR. N. H. ETHRIDGE  
ATTN: AMXBR-TB, MR. JULIUS J. MESZAROS  
ATTN: DR. N. J. HUFFINGTON
- 1 DIRECTOR, ADVANCED BALLISTIC MISSILE DEFENSE AGENCY, COMMONWEALTH BUILDING, 1320 WILSON BOULEVARD, ARLINGTON, VIRGINIA 22209  
ATTN: DR. JACOB B. GILSTEIN
- 1 COMMANDING OFFICER, ARMY COLD REGION RESEARCH ENGINEERING LAB, P. O. BOX 282, HANOVER, NEW HAMPSHIRE 03755
- 1 COMMANDING OFFICER, ARMY ENGINEER EXPLOSIVE EXCAVATION RESEARCH OFFICE, LAWRENCE LIVERMORE LABORATORY, LIVERMORE, CALIFORNIA 94550
- 8 DIRECTOR, ARMY ENGINEER WATERWAYS EXPERIMENT STATION, BOX 631, VICKSBURG, MISSISSIPPI 39180  
ATTN: WESNV  
ATTN: MR. G. E. ALBRITTON  
ATTN: MR. G. L. ARBUTHNOT  
ATTN: MR. T. E. KENNEDY  
ATTN: MR. J. GATZ  
ATTN: MR. D. W. MURRELL  
ATTN: MR. A. D. ROOKE  
ATTN: MR. J. N. STRANGE
- 1 CHIEF, ARMY SATELLITE COMMUNICATIONS AGENCY, FORT MONMOUTH, NEW JERSEY 07703  
ATTN: LTC MCGIVERN
- 1 COMMANDING OFFICER, ARMY TERRESTRIAL SCIENCES CENTER, P. O. BOX 282, HANOVER, NEW HAMPSHIRE 03755

COPIES

DEPARTMENT OF THE ARMY (CONTINUED)

- 1 ASSISTANT CHIEF OF STAFF FOR FORCE DEVELOPMENT,  
DEPARTMENT OF THE ARMY, WASHINGTON, D. C. 20310  
ATTN: DIRECTOR OF CHEMICAL AND NUCLEAR OPERATIONS
- 2 CHIEF OF ENGINEERS, DEPARTMENT OF THE ARMY,  
WASHINGTON, D. C. 20314  
ATTN: ENGME-RD  
ATTN: LTC G. CHASE
- 1 DEFENSE CIVIL PREPAREDNESS AGENCY, WASHINGTON, D. C.  
20301  
ATTN: STAFF DIRECTOR, RE(SR), MR. GEORGE N. SISSON
- 1 COMMANDING OFFICER, FRANKFORD ARSENAL, BRIDGE AND  
TACONY STREETS, PHILADELPHIA, PENNSYLVANIA 19137  
ATTN: MR. B. SCHEIN
- 1 DEPARTMENT OF THE ARMY, HARRY DIAMOND LABORATORIES,  
WASHINGTON, D. C. 20438  
ATTN: AMXDO-NP, MR. F. M. WIMINITZ
- 1 COMMANDING OFFICER, PICATINNY ARSENAL, DOVER, NEW  
JERSEY 07801  
ATTN: MR. A. FLUGER
- 1 SAFEGUARD SYSTEM MANAGER, SAFEGUARD SYSTEM OFFICE,  
1300 WILSON BOULEVARD, ARLINGTON, VIRGINIA 22209  
ATTN: CSSSO
- 2 DIRECTOR, U. S. ARMY ADVANCED BALLISTIC MISSILE DEFENSE  
AGENCY, HUNTSVILLE OFFICE, P. O. BOX 1500, HUNTSVILLE,  
ALABAMA 35807  
ATTN: CRDABH-S, MR. MELVIN T. CAPPS
- 1 U. S. ARMY COMBAT DEVELOPMENTS COMMAND, NUCLEAR  
AGENCY, FORT BLISS, TEXAS 79916
- 1 CHIEF, U. S. ARMY COMBAT DEVELOPMENTS COMMAND,  
COMMUNICATIONS-ELECTRONICS AGENCY, FORT MONMOUTH,  
NEW JERSEY 07703  
ATTN: CSG-CE-M
- 1 COMMANDING GENERAL, U. S. ARMY COMPUTER SYSTEMS  
COMMAND, FORT BELVOIR, VIRGINIA 22060  
ATTN: CSC-EN

COPIES

DEPARTMENT OF THE ARMY (CONTINUED)

- 2 COMMANDING GENERAL, U. S. ARMY ELECTRONICS COMMAND,  
FORT MONMOUTH, NEW JERSEY 07703  
ATTN: AMSEL-GG-EI  
ATTN: AMSEL-KL-I
- 3 COMMANDING GENERAL, U. S. ARMY MATERIEL COMMAND,  
WASHINGTON, D. C. 20315  
ATTN: AMCRD-B  
ATTN: AMCRD-BN-RE-2, MR. JOHN J. F. CORRIGAN  
ATTN: MR. B. H. STOUT
- 1 COMMANDING GENERAL, U. S. ARMY MISSILE COMMAND,  
REDSTONE ARSENAL, HUNTSVILLE, ALABAMA 35809  
ATTN: AMSMI-PLD, MR. BOUNDS
- 1 COMMANDING OFFICER, U. S. ARMY MOBILITY EQUIPMENT R  
AND D CENTER, FORT BELVOIR, VIRGINIA 22060  
ATTN: SMEFB-EAX, MR. D. B. DINGER
- 1 COMMANDING GENERAL, U. S. ARMY SAFEGUARD SYSTEM  
COMMAND, P.O. BOX 1500, HUNTSVILLE, ALABAMA 35807  
ATTN: SSC-DH, COL ROBERT A. PURPLE
- 1 COMMANDING GENERAL, U. S. ARMY TANK AUTOMOTIVE  
COMMAND, WARREN, MICHIGAN 48089  
ATTN: MR. C. HENNE
- 1 COMMANDING GENERAL, U. S. ARMY TEST AND EVALUATION  
COMMAND, ABERDEEN PROVING GROUND, MARYLAND 21005  
ATTN: AMSTE-NB
- 1 DEPARTMENT OF THE ARMY, U. S. ARMY WEAPONS COMMAND  
HEADQUARTERS, ROCK ISLAND, ILLINOIS 61201  
ATTN: MR. R. O. BORDER
- 1 COMMANDING GENERAL, WHITE SANDS MISSILE RANGE, NEW  
MEXICO 88002  
ATTN: TE-N, MR. MARVIN P. SQUIRES

DEPARTMENT OF THE NAVY

- 1 CHIEF OF NAVAL MATERIAL, NAVY DEPARTMENT, WASHINGTON,  
D. C. 20360  
ATTN: MAT 0323, MR. IRVING JAFFE

COPIES

DEPARTMENT OF THE NAVY (CONTINUED)

- 1 CHIEF OF NAVAL OPERATIONS, NAVY DEPARTMENT,  
WASHINGTON, D. C. 20350  
ATTN: OP-985F, CDR STOCKING
- 2 CHIEF OF NAVAL RESEARCH, DEPARTMENT OF THE NAVY,  
ARLINGTON, VIRGINIA 22217  
ATTN: CODE 418, DR. THOMAS P. QUINN  
ATTN: TECHNICAL INFORMATION SERVICES
- 7 COMMANDING OFFICER, NAVAL CIVIL ENGINEERING  
LABORATORY, PORT HUENEME, CALIFORNIA 93043  
ATTN: DR. WARREN A. SHAW  
ATTN: MR. J. R. ALLGOOD  
ATTN: MR. R. S. CHAPLER  
ATTN: MR. J. A. NORBUTAS  
ATTN: MR. R. H. SEABOLD  
ATTN: MR. S. K. TAKAHASHI  
ATTN: MR. D. E. WILLIAMS
- 1 COMMANDER, NAVAL ELECTRONIC SYSTEMS COMMAND  
HEADQUARTERS, WASHINGTON, D. C. 20360  
ATTN: PME 117-21
- 1 COMMANDER, NAVAL FACILITIES ENGINEERING COMMAND,  
COMMAND HEADQUARTERS, WASHINGTON, D. C. 20390  
ATTN: CODE 03A, MR. STANLEY ROCKEFELLER
- 2 COMMANDER, NAVAL ORDNANCE LABORATORY, SILVER SPRING,  
MARYLAND 20910  
ATTN: CODE 121, NAVY NUCLEAR PROGRAMS OFFICE  
ATTN: CODE 241, MR. JOSEPH PETES
- 1 COMMANDER, NAVAL ORDNANCE SYSTEMS COMMAND  
HEADQUARTERS, WASHINGTON, D. C. 20360  
ATTN: ORD-035D, MR. WILLIAM W. BLAINE
- 1 DIRECTOR, NAVAL RESEARCH LABORATORY, WASHINGTON, D. C.  
20390
- 2 COMMANDER, NAVAL SHIP RESEARCH AND DEVELOPMENT  
CENTER, BETHESDA, MARYLAND 20034  
ATTN: CODE 745, MR. EDWARD T. HABIB  
ATTN: MR. W. R. CONLEY

COPIES

DEPARTMENT OF THE NAVY (CONTINUED)

- 1 COMMANDER, NAVAL SHIP SYSTEMS COMMAND, NAVAL SHIP  
SYSTEMS COMMAND HEADQUARTERS, WASHINGTON, D. C. 20360  
ATTN: SHIPS 03541, MR. WILLIAM S. BROWN
- 1 COMMANDER, NAVAL WEAPONS CENTER, CHINA LAKE,  
CALIFORNIA 93555
- 1 COMMANDER, NAVAL WEAPONS LABORATORY, DAHLGREN,  
VIRGINIA 22448  
ATTN: TIEC

DEPARTMENT OF THE AIR FORCE

- 1 COMMANDER, AF SPECIAL WEAPONS CENTER, AFSC, KIRTLAND  
AFB, NEW MEXICO 87117  
ATTN: MR. R. CLARK
- 6 AF WEAPONS LABORATORY, AFSC, KIRTLAND AFB, NEW MEXICO  
87117  
ATTN: MR. J. L. BRATTON  
ATTN: MAJOR WILLIAM WHITTAKER  
ATTN: DEV, DR. HENRY COOPER  
ATTN: MR. C. E. NEEDHAM  
ATTN: DOGL, TECHNICAL LIBRARY  
ATTN: MAJOR LEIGH
- 2 CHIEF, AIR FORCE AUDIO-VISUAL CENTER, NORTON AFB,  
CALIFORNIA 92409  
ATTN: MR. K. HACKMAN  
ATTN: MR. G. PRATT
- 1 HEADQUARTERS, AIR FORCE SYSTEMS COMMAND, ANDREWS  
AFB, WASHINGTON, D. C. 20331  
ATTN: DEE
- 2 CHIEF OF STAFF, U. S. AIR FORCE, WASHINGTON, D. C. 20330  
ATTN: RD (DCS, RESEARCH & DEVELOPMENT)
- 1 SPACE AND MISSILE SYSTEMS ORGANIZATION, AFSC, NORTON  
AFB, CALIFORNIA 92409  
ATTN: LIEUTENANT COLONEL J. CAHOON

COPIES

ATOMIC ENERGY COMMISSION

- 1 ASSISTANT GENERAL MANAGER FOR MILITARY APPLICATION,  
U. S. ATOMIC ENERGY COMMISSION, WASHINGTON, D. C. 20545  
ATTN: DOCUMENT CONTROL FOR RES. & DEV. BRANCH
- 1 SANDIA LABORATORIES, P. O. BOX 5800, ALBUQUERQUE, NEW  
MEXICO 87115  
ATTN: DOCUMENT CONTROL FOR MR. J. W. REED

OTHER GOVERNMENT AGENCY

- 1 DEPARTMENT OF THE INTERIOR, U. S. GEOLOGICAL SURVEY,  
601 EAST CEDAR STREET, FLAGSTAFF, ARIZONA 86001  
ATTN: DR. DAVID J. RODDY, ASTROGEOLOGIC STUDIES

DEPARTMENT OF DEFENSE CONTRACTORS

- 3 BELL TELEPHONE LABORATORIES, INC., MOUNTAIN AVENUE,  
MURRAY HILL, NEW JERSEY 07971  
ATTN: DR. E. F. WITT  
ATTN: MR. MEAD F. STEVENS  
ATTN: MR. R. W. MAYO
- 1 GENERAL AMERICAN TRANSPORTATION CORPORATION, GENERAL  
AMERICAN RESEARCH DIVISION, 7449 NORTH NATCHEZ AVENUE,  
NILES, ILLINOIS 60648
- 1 GENERAL ELECTRIC COMPANY, TEMPO-CENTER FOR ADVANCED  
STUDIES, 816 STATE STREET (P. O. DRAWER QQ), SANTA  
BARBARA, CALIFORNIA 93102  
ATTN: DASAC
- 3 LOVELACE FOUNDATION FOR MEDICAL EDUCATION AND RES. ,  
5200 GIBSON BOULEVARD, SE. , ALBUQUERQUE, NEW MEXICO  
87108  
ATTN: PRESIDENT-DIRECTOR, DR. CLAYTON S. WHITE  
ATTN: ASSOCIATE SCIENTIST, DR. E. ROYCE FLETCHER  
ATTN: DR. D. R. RICHMOND
- 1 UNIVERSITY OF NEW MEXICO, DEPT. OF CAMPUS SECURITY AND  
POLICE, ALBUQUERQUE, NEW MEXICO 87106  
ATTN: ERIC H. WANG CIVIL ENG. RESEARCH FACILITY
- 2 PHYSICS INTERNATIONAL COMPANY, 2700 MERCED STREET,  
SAN LEANDRO, CALIFORNIA 94577  
ATTN: MR. C. T. VINCENT  
ATTN: MR. FRED M. SAUER

COPIES

DEPARTMENT OF DEFENSE CONTRACTORS (CONTINUED)

- 1 TRW SYSTEMS GROUP, ONE SPACE PARK, REDONDO BEACH,  
CALIFORNIA 90278  
ATTN: MR. F. A. FEIPER
- 1 URS RESEARCH COMPANY, 155 BOVET ROAD, SAN MATEO,  
CALIFORNIA 94402  
ATTN: MR. C. WILTON
- 1 WEIDLINGER, PAUL, CONSULTING ENGINEER, 110 EAST 59TH  
STREET, NEW YORK, NEW YORK 10022  
ATTN: DR. MELVIN L. BARON

MISCELLANEOUS

- 1 CANADIAN GENERAL ELECTRIC, 3603 8TH STREET, SE.,  
CALGARY, ALBERTA, CANADA  
ATTN: MR. D. J. DALTON
- 7 CHIEF SUPERINTENDENT, DEFENCE RESEARCH ESTABLISHMENT,  
SUFFIELD, RALSTON, ALBERTA, CANADA  
ATTN: MR. A. P. R. LAMBERT  
ATTN: MR. A. M. PATTERSON  
ATTN: MR. R. C. WYLD  
ATTN: MR. F. DAVEY  
ATTN: MR. R. B. HARVEY  
ATTN: MR. D. LITTLE  
ATTN: MR. W. HART

UNCLASSIFIED

Security Classification

DOCUMENT CONTROL DATA - R & D		
<i>(Security classification of title, body of abstract and indexing annotation must be entered when the overall report is classified)</i>		
1. ORIGINATING ACTIVITY (Corporate author) Defense Nuclear Agency Washington, D. C. 20305		2a. REPORT SECURITY CLASSIFICATION UNCLASSIFIED
		2b. GROUP
3. REPORT TITLE Blast Valve Tests		
4. DESCRIPTIVE NOTES (Type of report and inclusive dates) Final Report of Projects LN-109 and LN-116, DIAL PACK and PRAIRIE FLAT Events, accomplished on MIDDLE NORTH Series.		
5. AUTHOR(S) (First name, middle initial, last name) George Nevrincean and Eugene F. Witt, Bell Telephone Laboratories, Inc., Whippany, New Jersey 07981		
6. REPORT DATE 8 December 1972	7a. TOTAL NO. OF PAGES 104	7b. NO. OF REFS 10
8a. CONTRACT OR GRANT NO.	9a. ORIGINATOR'S REPORT NUMBER(S) POR-6472 (WT-6472)	
b. PROJECT NO. LN-109 and LN-116		
c.	9b. OTHER REPORT NO(S) (Any other numbers that may be assigned this report)	
d.		
10. DISTRIBUTION STATEMENT Approved for public release; distribution unlimited.		
11. SUPPLEMENTARY NOTES	12. SPONSORING MILITARY ACTIVITY DOD/DNA	
13. ABSTRACT A modified section of an underground communication building was constructed at the Defence Research Establishment, Suffield, and experiments were conducted to determine blast-valve performance, overpressures in the air shaft and downstream plenums, and overpressure damage to air ducts. The air ducts were installed in order to give an indication of the expected damage to air-conditioning equipment which would be caused by overpressure pulses. The experiments were conducted in the PRAIRIE FLAT and DIAL PACK Events. Both experiments employed 500 tons of TNT to produce the blast effects. In the PRAIRIE FLAT Event, the test structure was engulfed by a peak free-field blast overpressure of 34 psi. Two louver blast valves were mounted in the structure. One was closed directly by the blast forces and suffered no damage. That was not the case for the air ducts located in the downstream plenum. The other blast valve was properly controlled to close before blast arrival. In the DIAL PACK Event, the test structure was engulfed by a 12-psi blast overpressure. A louver blast valve and a lighter weight blast shutter were both blast closed. Air ducts behind the louver valve were only slightly indented, and those behind the blast shutter were undamaged.		

DD FORM 1 NOV 65 1473

UNCLASSIFIED

Security Classification

UNCLASSIFIED

Security Classification

14. KEY WORDS	LINK A		LINK B		LINK C	
	ROLE	WT	ROLE	WT	ROLE	WT
MIDDLE NORTH Series						
PRAIRIE FLAT Event						
DIAL PACK Event						
Blast valves						
Louver blast valve						
Blast shutter						
Air blast						
Overpressures						
Air-shaft overpressures						
Sheet-metal ducts						
Blast damage						
Plenum overpressures						
Air duct blast damage						
Blast closing valves						
Remote signal closing valves						

UNCLASSIFIED

Security Classification