

REPORT DOCUMENTATION PAGE

Form Approved
OMB No. 0704-0188

Public reporting burden for this collection of information is estimated to average 1 hour per response, including the time for reviewing instructions, searching existing data sources, gathering and maintaining the data needed, and completing and reviewing the collection of information. Send comments regarding this burden estimate or any other aspect of this collection of information, including suggestions for reducing this burden, to Washington Headquarters Services, Directorate for Information Operations and Reports, 1215 Jefferson Davis Highway, Suite 1204, Arlington, VA 22202-4302, and to the Office of Management and Budget, Paperwork Reduction Project (0704-0188), Washington, DC 20503.

1. AGENCY USE ONLY (Leave blank)		2. REPORT DATE Dec. 1970	3. REPORT TYPE AND DATES COVERED Final	
4. TITLE AND SUBTITLE Guide for Mathematical Modeling and Dynamic Shock Analysis of Rudders, Rudder Stock and Bearings			5. FUNDING NUMBERS unknown	
6. AUTHOR(S) unknown				
7. PERFORMING ORGANIZATION NAME(S) AND ADDRESS(ES) Supervisor of Ship Building Conversion and Repair, USN Third Naval District Brooklyn, NY 11232			8. PERFORMING ORGANIZATION REPORT NUMBER unknown	
9. SPONSORING/MONITORING AGENCY NAME(S) AND ADDRESS(ES) Same as above			10. SPONSORING/MONITORING AGENCY REPORT NUMBER unknown	
11. SUPPLEMENTARY NOTES				
12a. DISTRIBUTION/AVAILABILITY STATEMENT Available for public release			12b. DISTRIBUTION CODE A	
13. ABSTRACT (Maximum 200 words) Please see Attached. (The highlighted sections give a good simple summary or abstract.)				
14. SUBJECT TERMS Ships, shipbuilding, rudders, bearings, rudder stock, shock analysis, specifications, mathematical modeling			15. NUMBER OF PAGES 62	
			16. PRICE CODE \$7.00	
17. SECURITY CLASSIFICATION OF REPORT u	18. SECURITY CLASSIFICATION OF THIS PAGE u	19. SECURITY CLASSIFICATION OF ABSTRACT u	20. LIMITATION OF ABSTRACT u	

Reproduced From
Best Available Copy

20011005 102

I. INTRODUCTION

Recent shipbuilding and procurement specifications have included a requirement for a dynamic shock analysis to be performed for Rudders, Rudder Stocks and Rudder Bearings, among other shipboard equipment and systems. The specifications have generally required that a mathematical model report and dynamic analysis report be submitted to the Supervisor of Shipbuilding, Conversion and Repair, USN, THIRD Naval District for review and approval.

In an effort to provide general guidance and to aid in the design, development and production of shock resistant equipment, the Navy prepared reference (1) which presented a method for the shock design of shipboard equipment by dynamic analysis. The Navy provided additional general guidance in the form of various other publications, by sponsoring a technical review course in shock design, and by making available upon request, an individual consulting service (through SUPSHIP THREE).

As time passed, and as similar systems were analyzed independently by various engineers, it became apparent that a more specific type of guidance in the form of experience gained from past endeavors could and should be made available. This report, developed in order to aid in the preparation of mathematical model and dynamic analysis reports for rudders, is one of a proposed series of reports for various systems. The guidance provided by this report is based upon an accumulation of data from previous approved dynamic analyses and other pertinent engineering studies. This report therefore, should be considered as a record of past approaches, techniques, methods and assumptions that have been utilized in solving dynamic analyses of rudders. The responsibility for the contents (and justification of the contents) of a mathematical model and dynamic analysis still properly resides with the individual analyst.

It is to be understood that the techniques and assumptions associated with modeling and analysis are constantly being modified, refined and updated as more pertinent information becomes available. It is intended that this report be revised periodically so as to reflect any advances or modifications to present methods of predicting shock stresses in rudder assemblies.

The character of this report requires that the guidance contained herein be of a very general nature. All possible design situations may not be covered. Thus, the omission in this report of unique design characteristics such as a rudder supported by a pintle and skeg arrangement or a rudder that is controlled by a rudder actuator rather than a tiller-steering gear arrangement, should not imply that the analyst need not consider these items for inclusion in his mathematical model.

The basic strength factors to be considered in the design of any rudder assembly are:

UNCLASSIFIED



GUIDE FOR
MATHEMATICAL MODELING
AND
DYNAMIC SHOCK ANALYSIS
OF
RUDDERS, RUDDER STOCKS AND
BEARINGS

TECHNICAL REPORT

SUPERVISOR OF SHIPBUILDING,
CONVERSION AND REPAIR, USN
THIRD NAVAL DISTRICT
BROOKLYN, NEW YORK 11232



AGU02-01-0027

GUIDE FOR
MATHEMATICAL MODELING
AND
DYNAMIC SHOCK ANALYSIS
OF
RUDDERS, RUDDER STOCKS AND
BEARINGS

SUPERVISOR OF SHIPBUILDING
CONVERSION AND REPAIR
USN, THIRD NAVAL DISTRICT

This document is subject to
export controls and
distribution to foreign
governments or foreign
nationals may be made only
with prior approval of
(Supervisor of Shipbuilding, 3ND)

DECEMBER 1970

Report No. SUPSHIP 280-2

FOREWORD

This report contains guidance for the development of mathematical model and dynamic analysis reports of Rudders, Rudder Stocks and Bearings. Copies of this document may be obtained from:

DEPARTMENT OF THE NAVY
Supervisor of Shipbuilding
Conversion and Repair, USN
THIRD Naval District
3rd Avenue & 29th Street
Brooklyn, New York 11232

All recommendations for additions, deletions and/or corrections should be forwarded to the above address.

PROBLEM STATUS

This is an interim report on one phase of the problem; work is continuing.

AUTHORIZATION

This report was authorized by NAVSHIPS letter 9020 Ser 052-42 of 3 April 1967.

TABLE OF CONTENTS

	<u>Page No.</u>
I INTRODUCTION	1
II BASIC ASSUMPTIONS	2
III CRITICAL AREAS TO BE INVESTIGATED	3
IV MATHEMATICAL MODEL	8
1. Modeling Technique	8
2. Modeling Procedure	8
3. Vertical Model	9
4. Athwartship Model	9
5. Fore & Aft Model	10
6. Influence Coefficients	10
7. Mathematical Model Report Format and Content	12
V DYNAMIC ANALYSIS	14
1. Computer Program	14
2. Dynamic Analysis Report Format and Content	15
3. Checks on Analysis	16
4. Stress Analysis	18
a. Combining Stresses	18
b. Summing Stresses and Deflections Across the Modes	19
c. Number of Modes to Use	20
VI REFERENCES	21
VII BIBLIOGRAPHY	21
APPENDIX I - Sample, Vertical Model and Dynamic Shock Analysis for a Rudder System	I-1
APPENDIX II- Sample, Athwartship Model and Dynamic Shock Analysis for a Rudder System	II-1
A Method for Calculating the Added Mass for Entrained Water	II-20
APPENDIX III- Sample Summary Sheets	III-1

LIST OF FIGURES

	<u>Page No.</u>
Figure 1 - General Arrangement of Rudder Assembly (Typical)	5
Figure 2 - Location of Mass Lumps for Athwartship Mathematical Model (Typical)	6
Figure 3 - Schematic Diagram of Athwartship Mathematical Model (Typical)	7
Figure 4a - Cut Away View of Rudder Stock Bearings	11
Figure 4b - Spring - Mass System (3 Mass Vertical)	11

I. INTRODUCTION

Recent shipbuilding and procurement specifications have included a requirement for a dynamic shock analysis to be performed for Rudders, Rudder Stocks and Rudder Bearings, among other shipboard equipment and systems. The specifications have generally required that a mathematical model report and dynamic analysis report be submitted to the Supervisor of Shipbuilding, Conversion and Repair, USN, THIRD Naval District for review and approval.

In an effort to provide general guidance and to aid in the design, development and production of shock resistant equipment, the Navy prepared reference (1) which presented a method for the shock design of shipboard equipment by dynamic analysis. The Navy provided additional general guidance in the form of various other publications, by sponsoring a technical review course in shock design, and by making available upon request, an individual consulting service (through SUPSHIP THREE).

As time passed, and as similar systems were analyzed independently by various engineers, it became apparent that a more specific type of guidance in the form of experience gained from past endeavors could and should be made available. This report, developed in order to aid in the preparation of mathematical model and dynamic analysis reports for rudders, is one of a proposed series of reports for various systems. The guidance provided by this report is based upon an accumulation of data from previous approved dynamic analyses and other pertinent engineering studies. This report therefore, should be considered as a record of past approaches, techniques, methods and assumptions that have been utilized in solving dynamic analyses of rudders. The responsibility for the contents (and justification of the contents) of a mathematical model and dynamic analysis still properly resides with the individual analyst.

It is to be understood that the techniques and assumptions associated with modeling and analysis are constantly being modified, refined and updated as more pertinent information becomes available. It is intended that this report be revised periodically so as to reflect any advances or modifications to present methods of predicting shock stresses in rudder assemblies.

The character of this report requires that the guidance contained herein be of a very general nature. All possible design situations may not be covered. Thus, the omission in this report of unique design characteristics such as a rudder supported by a pintle and skeg arrangement or a rudder that is controlled by a rudder actuator rather than a tiller-steering gear arrangement, should not imply that the analyst need not consider these items for inclusion in his mathematical model.

The basic strength factors to be considered in the design of any rudder assembly are:

- a. the thrust and torque loads that are resisted by keys and keyways,
- b. the deflection of the rudder stock, which is important in determining the crushing or compression loads on stave bearings,
- c. the bending moment in the rudder stock which is important in determining the adequacy of the rudder and rudder stock scantlings,
- d. the radial load reactions on both upper and lower bearings which are important for checking the bearings and determining the adequacy of the rudder scantlings, the bearing housing and structure,
- e. the thrust load which is important in determining the adequacy of the thrust bearing and the connection or holding means that secure the rudder to the rudder stock,
- f. the strength characteristics of the rudder blade.

The two sources from which the above information is derived are the hydrodynamic design criteria and the dynamic shock design criteria. It is important to note that the two sets of design criteria are not combined in determining the strength characteristics of the rudder assembly. The resulting assembly design from the separate sources of design criteria should be compared to determine which will govern in the final consideration of the rudder assembly strength. This report will only consider the rudder assembly design due to dynamic shock considerations. However, reference may be made to hydrodynamic load criteria to explain the considerations that are involved in establishing some of the simplifying assumptions that are incorporated in the modeling process.

Item f. above, for example, is not usually a major consideration in dynamic shock design. Experience has indicated that the effects of underwater explosions do not warrant the design of the rudder plating and internal support structure for shock.

II. BASIC ASSUMPTIONS

1. The Rudder assembly shall be analyzed for Grade "A" Shock. No plastic deformation is permitted in any component of the assembly except as indicated for effective yield stress in NAVSHIPS 250-423-30. Elastic input coefficients (Section 9400 of Ship's Specifications) will be used.
2. The angle of rudder attack is assumed to be zero. Therefore, no hydrodynamic forces are considered in the dynamic shock analysis.
3. All springs are to be considered completely elastic and linear.
4. Bearing clearances are to be assumed zero.
5. Oil and water film in bearings are assumed to have infinite stiffness.

6. All bearing supports are to be considered as knife edge supports. The point of support is considered to be the center of the bearing.
7. Flange faces of bolted joints are considered to remain in compression during shock due to bolt preload.
8. It may be assumed that the rudder assembly is unaffected by the shock response of the steering gear. The tiller (which is usually a part of the steering gear) will be stress analyzed by using the shock response of the rudder assembly.
9. The virtual mass effects of the surrounding water need not be included in the mathematical model of rudder assemblies, unless required by Ship's Specifications or other considerations. (See Appendix II regarding method of including entrained water).
10. The rudder is assumed to be in its normal, unflooded condition.
11. The X, Y, Z co-ordinate system origin of the mathematical model should be located on the axis of the rudder stock and preferably at the centerline of the upper bearing. Positive directions of the co-ordinate system should be defined in relation to the Ship's co-ordinates in the following manner:

(for origin at rudder stock)

X is positive in forward direction

Y is positive in upward direction

Z is positive in starboard direction

12. The basic hull structure (fixed base) is assumed to behave as a rigid member. Free body motions or flexural vibrations of the ship are to be neglected.
13. Non-metallic bearing material is considered as stiff as steel under shock loading.
14. In general, the fixed base is that ship's structural element supporting the equipment foundation which provides the prime path for the transmission of the shock loading from the ship to the equipment and for which design shock spectra inputs are specified. Design shock spectra inputs are specified for shell, hull and deck mounted equipment.

III. CRITICAL AREAS TO BE INVESTIGATED

Vertical Shock Direction

1. Stress in upper bearing foundation.
2. Stress in upper bearing.

3. Stress in all bolted connections.
4. Stress in rudder carrier ring.
5. Stress in carrier key or rudder stock bolt connection.
6. Stress in rudder hub.
7. Consideration must be given to the shock adequacy of the means by which the steering gear tiller is secured to the stock. If the tiller is located on the extreme upper end of the stock, as shown on Figure I, a cap plate may be provided.

Athwartship Shock Direction

1. Stress in rudder carrier ring and bolts.
2. Stresses in upper bearing (radial and thrust load capacity).
3. Stress in retainer rings.
4. Stresses in rudder stock.
5. Lower bearing (radial load capacity).
6. Bearing and shear stresses in keys and keyways.
7. Bending stress in rudder hub.
8. Stresses in upper and lower bearing foundations.

Fore & Aft Direction

In general, the fore and aft direction will not experience shock loads that will create stress levels greater than the athwartship stress. Some rudder arrangements may require considering the stress levels from the fore and aft shock direction.

NOTE: Foregoing listing represents the major critical areas to be investigated. Additional areas are to be included as determined by the designer for each individual application.

GENERAL ARRANGEMENT OF RUDDER ASSEMBLY

(Typical)

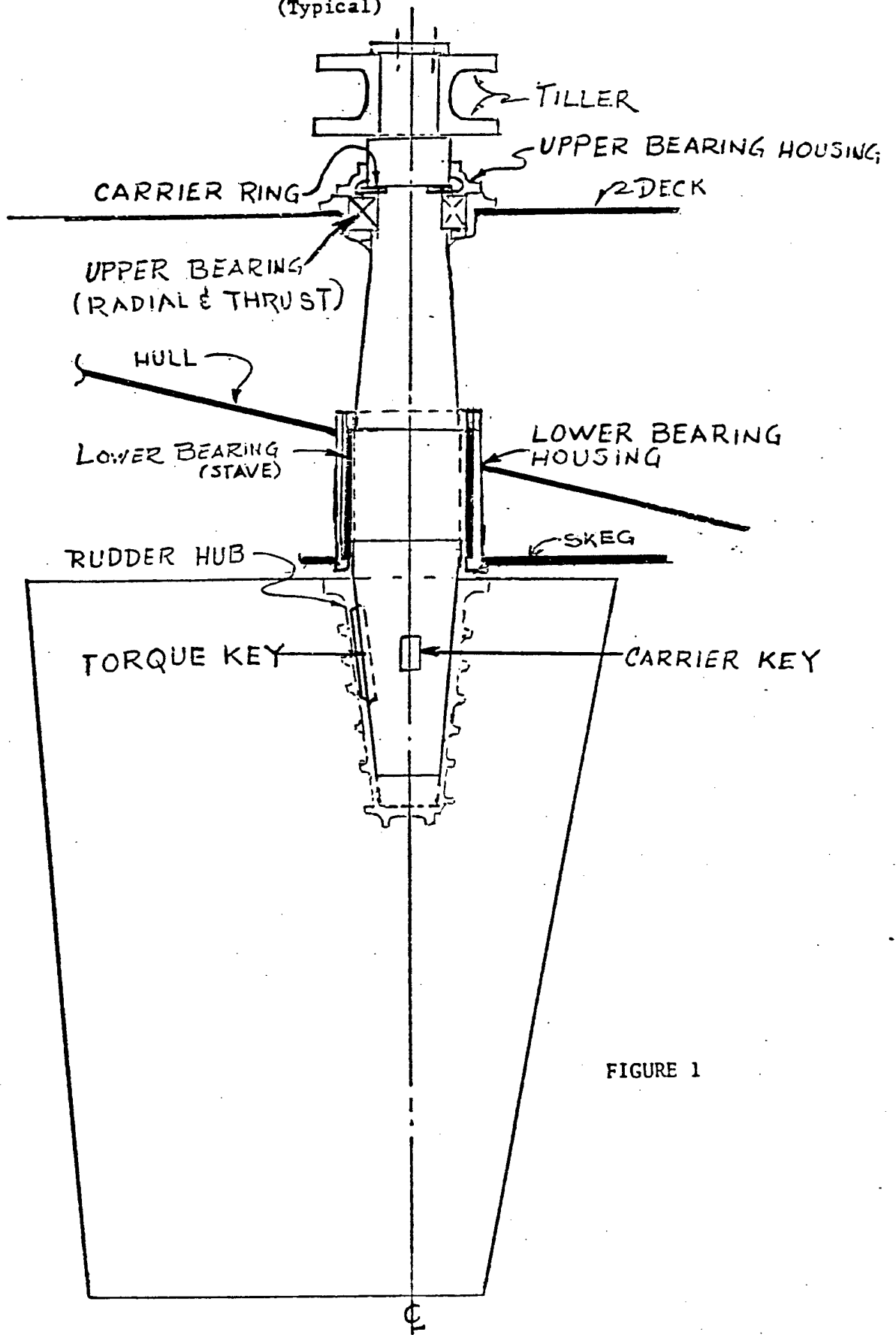

FIGURE 1

LOCATION OF MASS LUMPS FOR ATHWARTSHIP MATHEMATICAL MODEL

(Typical)

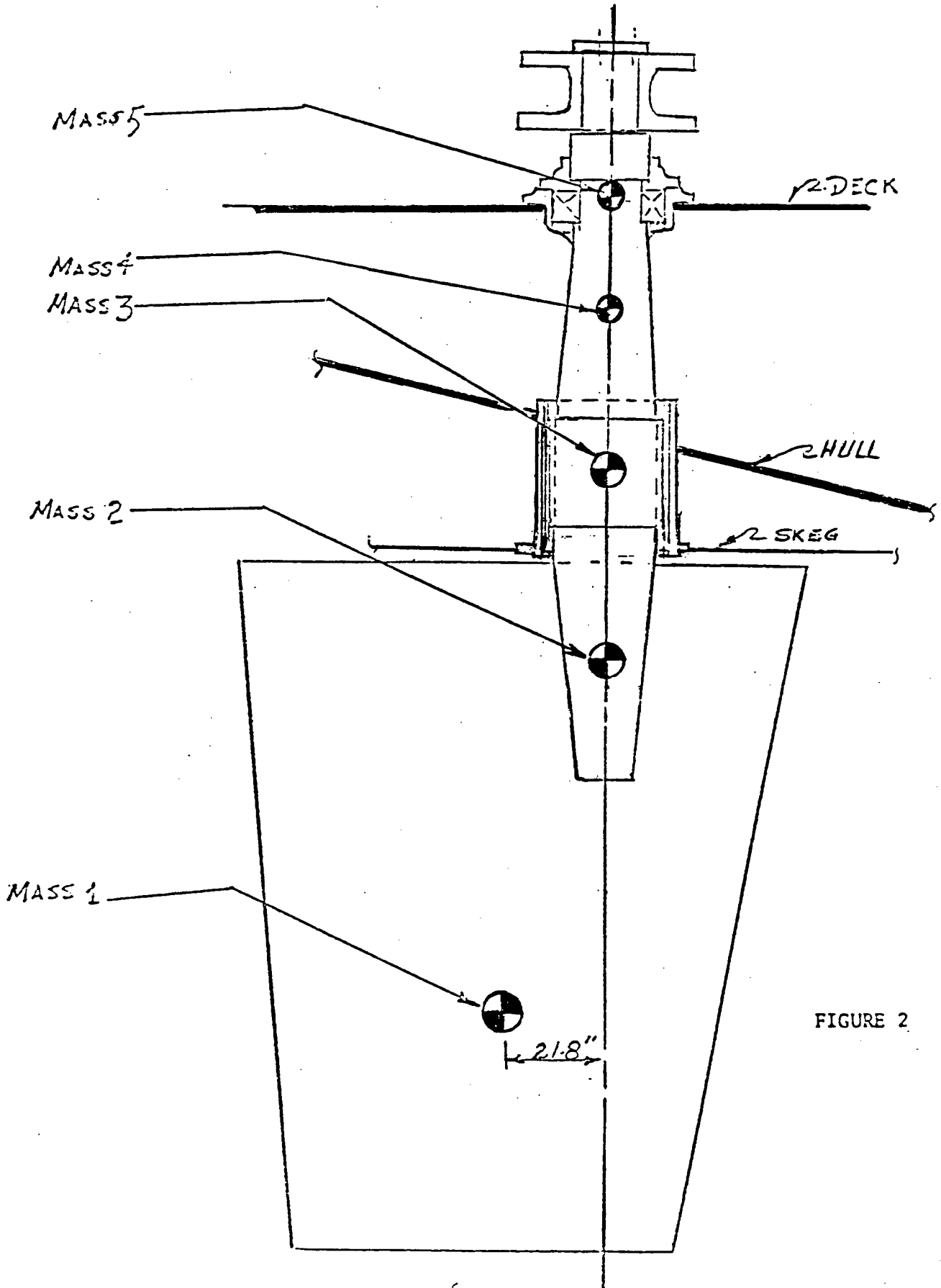

FIGURE 2

TYPICAL SCHEMATIC DIAGRAM OF
ATHWARTSHIP MATHEMATICAL MODEL (TYPICAL)

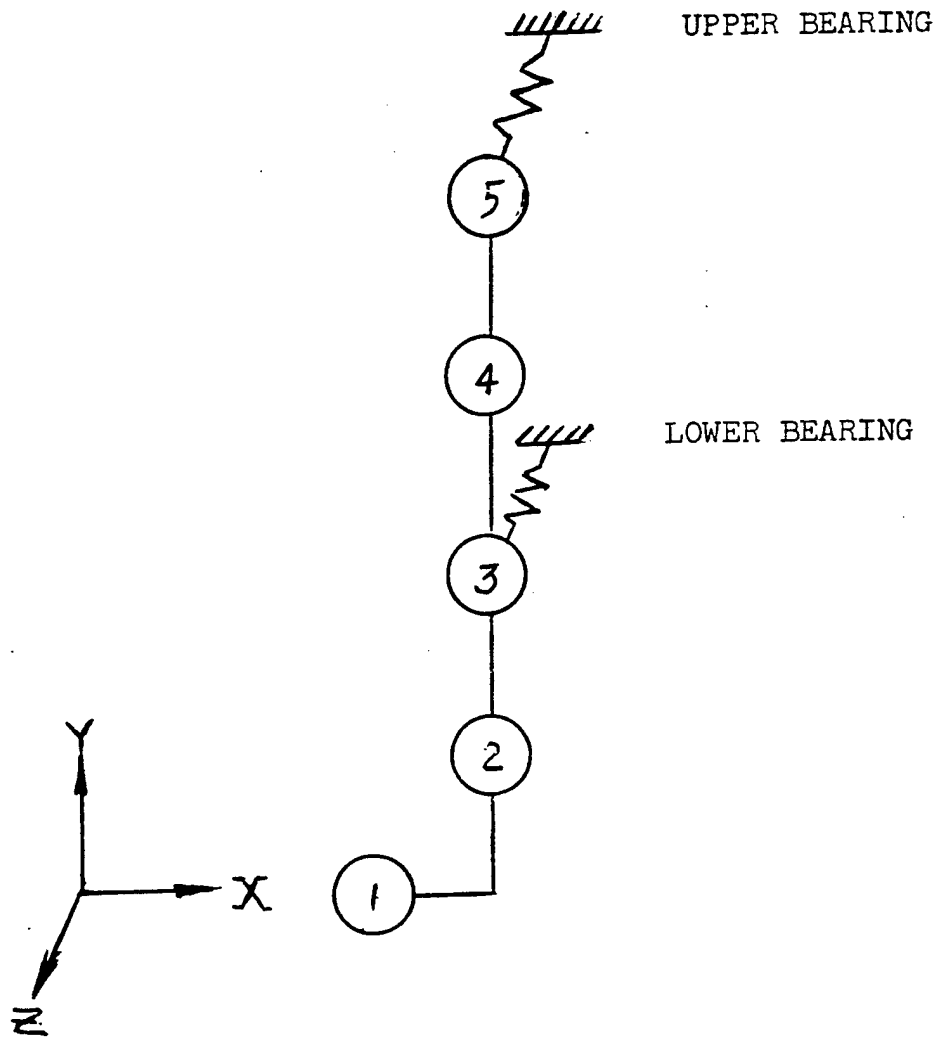

FIGURE 3

IV. MATHEMATICAL MODEL

1. Modeling Technique

The method to be used in this report is basically a simplified modal analysis method, in which it is assumed that the rudder assembly and its foundation together make up a system which responds as a linear elastic structure to the specified shock input. It is assumed that design analysis will normally be made in three orthogonal directions, vertical, athwartship and fore and aft. The input for each shock direction corresponds respectively to the design shock spectra specified for the three shock directions. The inertial loads derived by the dynamic analysis are imposed on the rudder assembly and an independent static stress analysis is performed for each mode of response that is considered. The stresses resulting from the static analysis of each mode are combined by means of the NRL summing technique described in Section 4.b of Chapter V.

2. Modeling Procedures

Two fundamental questions which must necessarily form the basis for the development of a mathematical model of any system are:

- a. What components of the system are to be modeled?
- b. How many lumped masses are required to adequately model a component?

With regard to question a., the designated areas of investigation (Chapter III) fairly well define what components are to be modeled. For example, if it is desired to obtain the bending stress in the rudder stock due to the dynamic response of the rudder stock, it is necessary to provide at least one model mass in the rudder stock span between the two support points (the upper and lower bearings). It should be noted that the fixed base natural frequency of various components is a significant parameter utilized to determine those areas which might be critical. In general, low frequency elements are to be modeled as separate masses.

With regard to question b., it is the general intent of the modeling procedure to represent system components with a sufficient number of concentrated masses to properly reflect the response of the highest mode of vibration which is expected to contribute to the stresses, deflections, etc. For example, if the second or third mode fixed base frequency of a particular assembly component is low in comparison with:

- a. the fixed base frequency of the other modeled components and/or
- b. an anticipated "frequency range of consideration" of the total assembly,

then additional masses would be required to reflect these modes of response. It should be noted however, that in general, rudder components exhibit high

fixed base frequencies. Therefore, the selection of mass lumps for rudder assemblies is generally based on the consideration of assembly configuration rather than on the comparison of frequencies, and separate mass lumps for individual components are unnecessary. Figures 2 and 3 would indicate that the athwartship model of a rudder assembly is analogous to a simply supported beam with an overhang. A minimum of two mass lumps, one at center span and one at the overhang, is required to model for the bending response in accordance with the location of the beam supports. If spring constants of the support points are considered, two additional mass lumps must be considered at the support points.

After the selection and arrangement of mass lumps have been determined, the model should be checked to insure that the summation of the individual masses equals the total system mass.

3. Vertical Shock Model

In the vertical shock analysis, there are two locations in a rudder system that require information to insure that the rudder will remain in place and operational after shock; the attachment of the rudder stock to the ship's hull structure, and the attachment of the rudder blade to the rudder stock. The attachment of the rudder stock to the ship's hull structure generally involves the upper bearing, the upper bearing housing, that part of the rudder stock above the attachment point, the weight of items supported by the rudder stock above the point of attachment (tiller or actuator) and the foundation that supports the attachment of the rudder stock to the ship's structure. With the exception of the foundation, the total weight of the above mentioned items may be lumped together. Additionally, that portion of the foundation weight (generally 50%) acting with the attachment components is included in this lumped mass.

The mass assignment of the rudder stock is dependent upon the spring characteristic of the stock. If the spring stiffness is higher in magnitude than that of the hull attachment, that part of the stock that is above the attachment of the rudder to the stock, may be lumped with the upper mass. If the stock stiffness is less than the hull attachment stiffness, the rudder stock should be modeled as a separate mass.

The rudder blade and its means of attachment to the rudder stock should be modeled as a separate mass.

Generally a three mass vertical model is sufficient to yield the information necessary to determine the shock adequacy of a rudder system. (See Figure 4b and Appendix I for sample vertical model).

4. Athwartship Shock Model

Figure 3 represents a typical athwartship model for a rudder assembly. The mass lumps have been selected on the basis of the information desired and in accordance with arrangements that are analogous to structural support situations where the dynamic behavior is easy to calculate. The following is a description of each mass lump to indicate the rationale involved:

a. Masses 1 and 2 consist of the portion of the assembly overhanging the lower bearing, and include the lower stock and the rudder. This portion will tend to reflect the prime frequency response of the system. These masses will supply information concerning the bending stress of the lower stock and the radial loads acting on the bearings.

b. Mass 3 will include the portion of the stock in the vicinity of the lower bearing and the lower bearing itself. This mass contributes directly to the radial loads acting on the bearings.

c. Mass 4 is that portion of the stock between the upper and lower bearings. This portion of the stock may have a response within the frequency range of consideration, and as such, may be significant. Inclusion of this mass will supply data concerning the bending stresses in that portion of the stock, and will result in more accurate values of radial loads acting on both bearings.

d. Mass 5 includes the upper stock in the vicinity of the upper bearing, the upper bearing itself, retaining ring, bearing retainer and carrier assembly, that portion of the stock above the upper bearing, the coverplate and steering gear tiller.

In all cases the masses are assumed to be concentrated at the actual center of gravity of the component parts. Figure 2 for this example indicates that the center of gravity for mass 1 is 21.8" off the centerline of the rudder stock. This eccentricity has been included in Figure 3, and the torsional influence should be incorporated when calculating influence coefficients.

5. Fore & Aft Shock Model

The analysis of the rudder due to fore/aft shock is generally not required for the following reasons:

a. The shock loads to which the rudder is subject, due to a fore/aft shock input, are considered to be less severe in all aspects than the shock loads imposed on the rudder due to athwartship shock.

b. All potential critical areas of the rudder (as designated in Chapter III) can be adequately examined for the most severe loading conditions by means of the vertical model and athwartship model.

6. Influence Coefficients

The calculating of influence coefficients is one of the most important steps in the performance of a dynamic analysis. The basic definition of an influence coefficient is the elastic displacement at mass M_j due to a unit force statically applied at mass M_j .

The development of influence coefficients for the vertical model of most rudder systems is relatively simple. The rudder stock may be considered as a short column (short enough to exclude the possibility of buckling). The elastic springs considered are usually the bending and shear deflections in the upper bearing housing and foundation, the column deflection of the rudder stock, and the deflection of the means by which the rudder is secured to the rudder stock.

Figures 4a and 4b graphically illustrate the considerations leading to the determination of the influence coefficients for a three mass vertical rudder model.

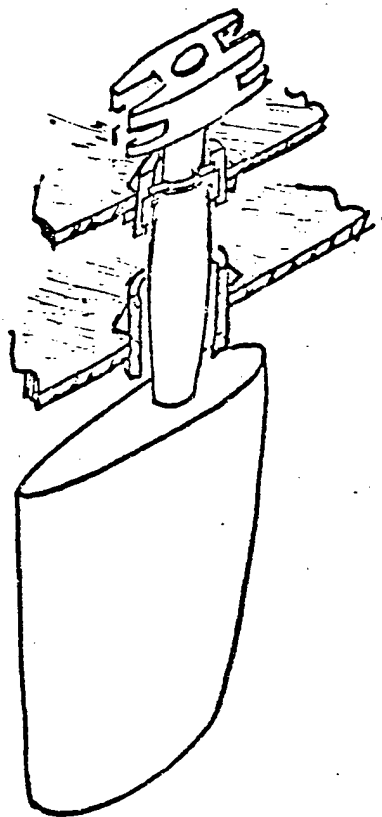

Cut away view showing rudder stock supported at upper bearing.

Fig. 4a

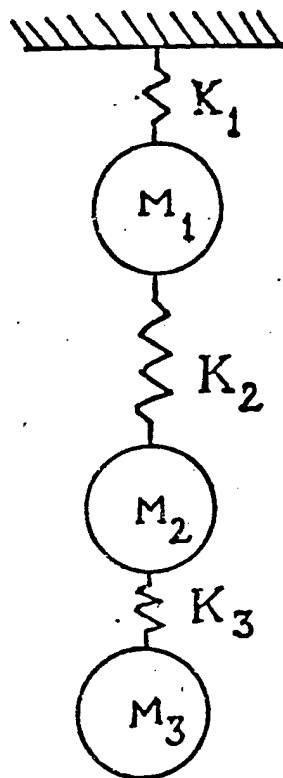

SPRING-MASS SYSTEM (3 mass vertical)

Fig. 4b

K_1 = Flexibilities in the upper bearing housing.

K_2 = Axial flexibilities in the rudder stock.

K_3 = shear flexibilities in the rudder carrier key.

The influence coefficients are the displacements under unit force, thus the influence coefficients are:

$$\begin{aligned} \delta_{11}, \delta_{12}, \delta_{13} &= \frac{1}{k_1} \\ \delta_{22}, \delta_{23} &= \frac{1}{k_1} + \frac{1}{k_2} \\ \delta_{33} &= \frac{1}{k_1} + \frac{1}{k_2} + \frac{1}{k_3} \end{aligned}$$

The influence coefficients for the athwartship shock model are the bending, shear and torsional deflections calculated for a continuous beam of variable cross-section, supported by the spring flexibilities of the upper and lower bearing housings. The following are some of the standard methods employed for these calculations:

Castigliano's Theorem

Moment - Area Method

Moment - Distribution Method

Slope - Deflection Method

An example of an athwartship dynamic analysis is included in Appendix II. As may be seen in this example, the actual moment of inertia calculation is quite extensive. It should be pointed out however, that this calculation is required for the stress analysis of the normal hydrostatic design. The information thus obtained may also be used in the dynamic analysis.

7. Mathematical Model Report Format and Content

a. The report should include an introductory section which describes the equipment being analyzed and its normal operating function, indicates the planned location in the ship and consequent inputs to be used, the grade of shock specified, the procurement specification, and a description of the proposed method of analysis.

b. The areas of the equipment which the supplier believes will be critical under shock loading shall be listed and discussed.

c. Simplifying assumptions which have been made in the preparation of the model should be indicated. Justification for such simplifications shall be provided and appropriate references cited.

d. An estimate of the weight and location of center of gravity of the equipment should be included. A listing of weights of components which are used to arrive at the equipment weight should be provided.

e. The proposed breakdown of the equipment for analysis should be described. The description should indicate how the proposed mass breakdown permits determination of stresses or deflections in the previously defined critical areas. The number and magnitude of model masses and their location with respect to a specified co-ordinate system should be indicated.

f. The characteristics of the foundation as provided by the shipbuilder should be included. The extent to which foundation elements will be used in the analysis should be noted.

g. Sketches or drawings should be included to indicate the arrangement of the equipment and the foundation.

h. The mathematical model for each direction of shock should be described by figures and text. The description will indicate how the mathematical model is formulated and what properties of the structure are considered at each point, e.g., shear deflection, bending of a beam-like member, compression, etc. By the above, the properties of the connections between masses will be explained without assigning a specific value to each of the connecting elements.

i. Calculations should be included to indicate the frequency associated with certain elements of the equipment, e.g. critical speed of a shaft, frequency of overhanging attachments such as a blower, etc. Since, in general, low frequency elements will be modeled as separate masses, natural frequencies of components should be calculated to determine if a separate model mass is required.

j. References should be indicated as to the source of analysis method, formulas used, constants and curves used, etc. Where results of a shock test of a similar type item are utilized to simplify the model, the specific shock test report should be indicated, and appropriate elements cited and discussed to substantiate the simplification.

k. As an attachment to the model report, equipment outline and assembly drawings, support, sub-base and foundation plans should be provided. Preliminary plans may be forwarded if final plans are not available. Modifications of plans which will affect the mathematical model should be forwarded as soon as they become available.

l. Drawings or suitable sketches showing equipment outline/ assembly and supporting structure, including ship's foundations and such other details as required to support an independent evaluation of the proposed mathematical model, should be included. Modification to equipment or supporting structure which may affect the mathematical model should be evaluated and forwarded as the information becomes available.

NOTE: This Section is Enclosure (2) of NAVSHIPSINST 9400.13.

V. DYNAMIC ANALYSIS

1. Computer Programs

A computer program which performs the computations associated with the dynamic design analysis method has been developed by the Navy and copies of the description report are available from the Defense Documentation Center, Cameron Station, Alexandria, Virginia 22314 or from the Supervisor of Shipbuilding, Conversion and Repair, USN, THIRD Naval District. (See page ii for address). The report title is:

David Taylor Model Basin Report 2262
"Normal Mode Computer Analysis of Structures"
by John H. Avila
(A D 651319)

The computer program presented uses the influence coefficient matrix or stiffness matrix associated with a lumped mass system, together with the masses, to generate the normal modes of vibration and the fundamental frequencies. Of primary importance is the fact that this routine accepts up to 60 degrees of freedom and is generally unaffected by repeated frequencies or frequencies which lie close together.

There are capabilities for treating externally redundant systems of certain types, thus alleviating the work of computing influence coefficient matrices for these cases. Examples of such systems are given.

One valuable routine can examine the input matrix of influence coefficients (or stiffnesses) and test for positive definiteness, i.e., whether all eigenvalues associated with the structure model are positive. Furthermore, if the test establishes the existence of negative eigenvalues, then the routine can locate certain areas of the input matrix where errors are likely to be present.

Several checks available to determine the reliability of the output are described and examples given.

A second computer program which also performs the computations associated with the dynamic design analysis method is INT-DDAM.

The inputs to this program, however, are the physical properties of the member (section properties, length of member, shear center, etc.) The program then develops the necessary stiffness matrix and carries the problem to completion (in some cases giving stresses as the final result).

This program is a time sharing program of the conversational mode type. It is generally commercially available via Time Sharing services.

Information on this program may be obtained from the Supervisor of Shipbuilding, Conversion and Repair, USN, THIRD Naval District. (see page ii for address).

2. Dynamic Analysis Report Format and Content

- a. The dynamic analysis report should indicate the input data utilized, the results of the mathematical treatment of the input data, and the results of the application of the dynamic loads to the system as defined by the model report.
- b. The input data should include calculations for obtaining spring constants, influence or stiffness coefficients, and the resultant mass and influence or stiffness coefficient matrices.
- c. The results of the analysis for each model should be reported; including modal frequency, mode shape, modal effective weight, participation factor, displacements, g's and forces. If computer output is used directly, adequate references and sufficient explanatory detail should be provided to facilitate review.

d. Tabulation summaries of calculated and allowable stresses and deflections should be included. Determination of allowable stresses shall be discussed, and factors such as operating temperatures and suitability of materials for dynamic loading shall be properly considered.

e. Details of calculations for stresses and deflections at critical areas, as defined in the mathematical model report, will be included. Adequate references to substantiate the stress analysis procedure should be included.

f. Where an overstress is indicated the proposed remedy for the condition will be indicated. The effect of any such changes on the overall analysis shall be evaluated and a recommended course of action indicated.

g. Since the foundation is included in the equipment analysis, the analysis report should contain a section which evaluates the adequacy of the foundation under the calculated dynamic loading.

NOTE: This Section is Enclosure (3) of NAVSHIPSINST 9400.13.

3. Checks on Analysis

a. For unidirectional analysis, the sum across the modes of the product of the participation factor times the normalized deflection of a mass is equal to 1.

$$\sum_{a=1}^N P_a \bar{X}_{ia} = 1$$

b. The trace of the mass-elastic matrix is equal to the sum of the eigenvalues.

c. The determinant of the mass-elastic matrix is equal to the product of the eigenvalues.

d. All the elements on the main diagonal of the mass-elastic matrix are positive, real and not zero.

e. An influence or stiffness coefficient matrix must be symmetrical about the main diagonal.

$$A_{ij} = A_{ji}$$

f. The square of an off-diagonal element cannot be greater than the product of its corresponding main diagonal elements.

g. The sum of the effective mass for the total number of modes is equal to the total mass of the model.

h. The laws of static equilibrium are valid for each mode:

(1) the algebraic sum of the reaction forces and inertia forces is zero.

(2) the sum of the moments at each point is zero.

(3) the sum of the shears is zero.

i. The algebraic summation of each element in the stiffness coefficient matrix equals the sum of the foundation springs attaching the model to the fixed base.

j. The sum across the modes of the modal effective mass times the frequency (radians) squared is equal to the sum of the foundation springs attaching the model to the fixed base.

$$\sum_{a=1}^N M_a \omega_a^2 = \sum K_{fdn. \text{ spring}}$$

4. Stress Analysis

a. Combining Stresses

Very often it is necessary to determine combined stresses in a structural member subjected to several normal stresses (at right angles to one another) plus one or more shear stresses. A very convenient combined stress formula is obtained from the Octahedral Shear Stress Theory as follows:

$$S_{\text{comb}} = \sqrt{S_x^2 + S_y^2 + S_z^2 - S_x S_y - S_y S_z - S_x S_z + 3T_{xy}^2 + 3T_{yz}^2 + 3T_{xz}^2}$$

where:

S = Normal Stress

T = Shear Stress

X, Y, Z = Subscripts indicating direction of normal and shear stresses.

Note that the above equation does not require the determination of principal stresses in order to combine all of the stresses.

Shear stresses in the stock (due to bending) should be reported. However, they generally need not be combined with the bending stresses developed from the dynamic analysis for the following reasons:

(1) Shear stresses are usually low compared to bending stresses.

(2) Shear stress is maximum at the neutral axis of the stock and zero at the outer diameter whereas bending stresses are maximum at the outer diameter and zero at the neutral axis of the shaft.

Torsional shear stresses (generally limited by the relief valve setting) should be combined (by Octahedral Shear Theory) with the total tensile or compressive stress at each point of interest along the stock.

S_{comb} as given above is not a shear stress. S_{comb} should be compared directly with (effective) yield stress.

b. Summing of Stresses and Deflections Across the Modes

The following formula shall be used when calculating the stress or relative deflection at a point i:

$$R_i = |R_{ia}| + \sqrt{\left[\sum_{b=1}^N (R_{ib})^2 \right] - (R_{ia})^2}$$

where:

$|R_{ia}|$ is the absolute value of the largest modal stress or deflection at point i, and R_{ib} represents all the stress or deflection contribution for the N modes. This formula is never to be used to combine modal forces on a mass(es) where these resultant forces are then to be used to calculate stresses or deflections.

Example: Suppose the following stresses were calculated for a point on a structure

Mode No.	Stress at i(Ksi)
1	12.2
2	-25.6
3	5.1
4	3.7
5	- 9.3

Then: $R_{ia} = -25.6$, and the formula is

$$R_i = 25.6 + \sqrt{12.2^2 + 5.1^2 + 3.7^2 + (-9.3)^2}$$

$$R_i = 42.2 \text{ ksi}$$

NOTE: This Section is based upon Reference 2.

c. Number of Modes to Use

Having developed a uni-directional mathematical model consisting of "n" lumped masses, the following guideline is provided as to the minimum number of modes which must be considered in the stress analysis.

n	* NUMBER OF MODES CONSIDERED IN STRESS ANALYSIS
1	1
2	2
3	2
4	2
5	3
6	3
-	-
-	-
n (odd)	$(n+1)/2$
n (even)	$\frac{n}{2}$

In addition to the above guideline, ship's specifications generally require consideration of a sufficient number of modes so that the total of modal weights considered will be not less than 80 percent of the total weight of the (actual) system.

The total weight of the actual system is the equipment weight plus the foundation weight considered and entrained water (if used).

NOTE: This Section is based upon Reference 2.

* Multiply the value in this column by the number of degrees of freedom per mass point if other than a uni-directional model is considered.

VI. REFERENCES

1. R. O. Belsheim and G. J. O'Hara, Shock Design of Shipboard Equipment - Dynamic Analysis Method, NAVSHIPS 250-423-30, May 1961.
2. G. J. O'Hara and R. O. Belsheim, Interim Design Values for Shock Design of Shipboard Equipment, NRL Memorandum Report 1396, (CONF) , February 1963.

VII. BIBLIOGRAPHY

1. Harris, C. M. and Crede, C. E., Shock and Vibration Handbook, McGraw-Hill, New York, 1961.
2. Jacobsen, L. S. and Ayre, R. S., Engineering Vibrations, McGraw-Hill, New York, 1958.
3. Norris, Hanson, Holley, Biggs, Namyet, Minami, Structural Design for Dynamic Loads, McGraw-Hill, New York, 1959.
4. O'Hara, G. J. and Cunniff, P. F., Elements of Normal Mode Theory, NRL Report 6002, August 12, 1964.
5. Roark, R. J., Formulas for Stress and Strain, McGraw-Hill, New York, Fourth Edition.
6. Saunders, H. E., Hydrodynamics in Ship Design, Society of Naval Architects and Marine Engineers, New York, 1957.
7. Thomson, W. T., Vibration Theory and Applications, Prentice Hall, 1965.

APPENDIX I

SAMPLE VERTICAL MODEL AND DYNAMIC SHOCK ANALYSIS
FOR A RUDDER SYSTEM

VERTICAL MODEL AND DYNAMIC SHOCK ANALYSIS FOR A RUDDER SYSTEM

Calculation of Spring Constants

The rudder arrangement shown in sketch 1 indicates that the entire rudder system is supported vertically at the deck level by the upper bearing housing. The rudder is secured to the rudder stock by the carrier key. This means that the flexibilities to be considered are in the bearing housing and foundation, the rudder stock and the rudder carrier key.

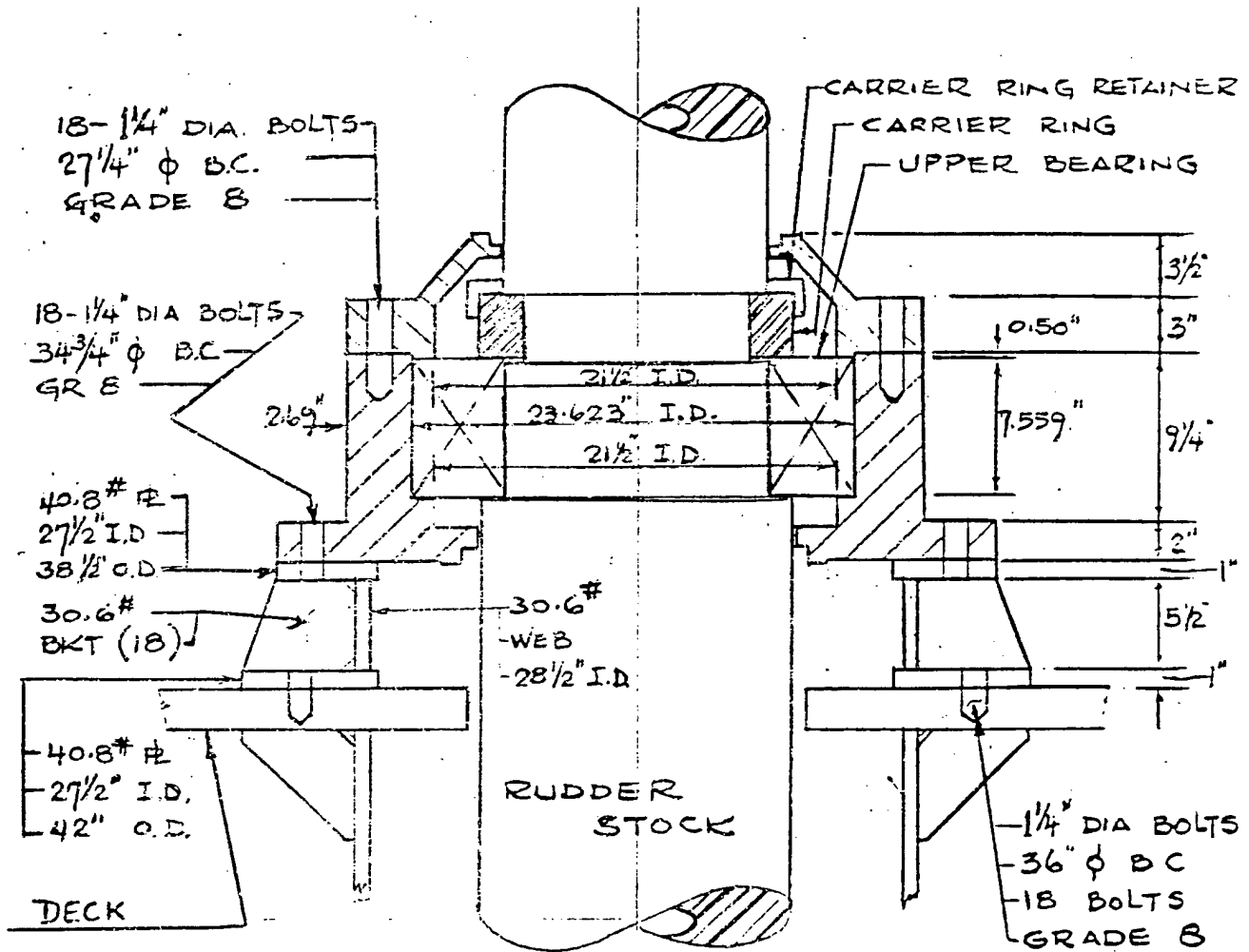

SKETCH 1

TYPICAL VERTICAL RUDDER SUPPORT

VERTICAL RUDDER SYSTEM
COMPONENT WEIGHT

<u>ITEM</u>	<u>WT. (Pounds)</u>
Rudder Stock	14,826
Cross head.	5,200
Upper Bearing	500
Upper Bearing Housing	1,785
Carrier Ring, Retainer and Seal	143
Upper Foundation	630
Rudder & Rudder Hub Casting	<u>11,500</u>
TOTAL SYSTEM WEIGHT -----	34,584

MASS ASSIGNMENT

Mass 1 - CROSSHEAD	5,200
Upper Bearing	500
1/2 Foundation (Upper Bearing)	315
CARRIER Ring, Retainer and Seal	143
UPPER BEARING Housing	1785
Upper 1/2 of Rudder Stock	7413
	<u>15,356 Lbs.</u>

$$M_1 = 15,356 \div 386 = 39.782 \text{ Lbs Sec}^2/\text{in}$$

Mass 2 - Rudder Stock,,Lower Half 7413 Lbs.

$$M_2 = 7413 \div 386 = 19.205 \text{ Lbs Sec}^2/\text{in}$$

Mass 3 - Rudder and Rudder Hub Casting 11,500 Lbs.

$$M_3 = 11,500 \div 386 = 29.793 \text{ Lbs Sec}^2/\text{in}$$

TOTAL MODEL WEIGHT----- 34,269 Lbs.

TOTAL SYSTEM WEIGHT ----- 34,584 Lbs.

PERCENTAGE OF SYSTEM WEIGHT MODELED----- 99.0%

Upper Bearing Housing & Foundation (Simplified)

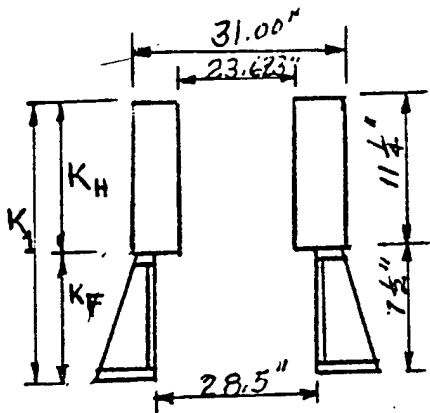

$$\Delta = \frac{PL}{AE} \quad K = \frac{P}{\Delta} = \frac{AE}{L}$$

$$A = .7845 (D_1^2 - D_2^2)$$

$$K_H = \frac{.7845 (31^2 - 23.623^2) \times 30 \times 10^6}{11.25} = 592.61 \times 10^6 \text{ \#/in.}$$

$$K_F = \frac{[.7845 (30^2 - 28.5^2) + (.75 \times 4 \times 18)] \times 30 \times 10^6}{7.5} = 491.64 \times 10^6 \frac{\#}{\text{in.}}$$

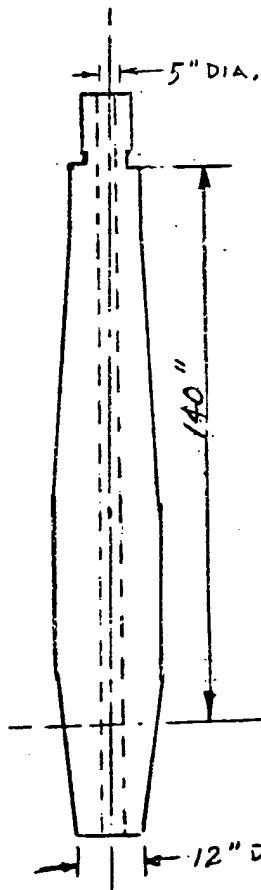

$$K_1 = \frac{1}{\frac{1}{K_H} + \frac{1}{K_F}} = \frac{K_H \times K_F}{K_H + K_F}$$

$$K_1 = \frac{592.61 \times 491.64}{592.61 + 491.64} \times 10^6 = 268.71 \times 10^6 \text{ \#/in}$$

Rudder Stock

$$* \text{ Average } A = .78539 (20.2^2 - 5^2) = 300.835 \text{ in}^2$$

$$K_2 = \frac{300.835 \times 30 \times 10^6}{140} = 64.46 \times 10^6 \text{ \#/in}$$

* Average area may be obtained by averaging inverse area along the length of the stock.

CARRIER KEY

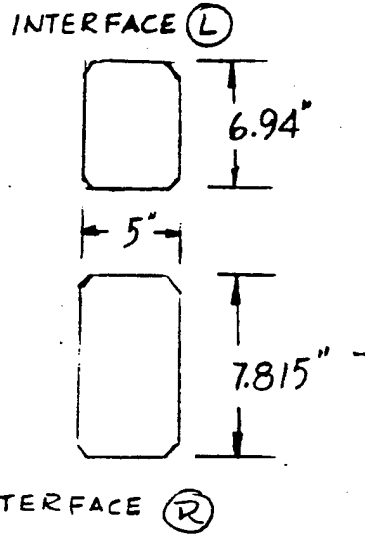
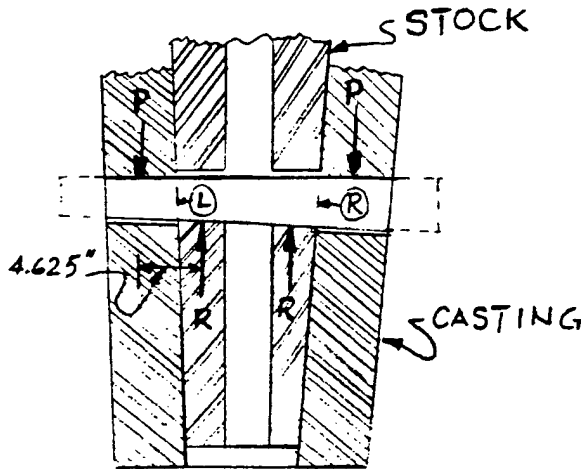

Width of Key = 5"

Average Key Area Left Side = 5" x 6.94" = 34.7 in²

Average Key Area Right Side = 5" x 7.815" = 39.075 in²

Deflection of Key:

a. Due to bending moment = neglected as bending deflection is negligible due to clearances.

b. Due to Shear $\Delta = \frac{WL}{AG}$ $K = \frac{L}{\Delta} = \frac{AG}{L}$

WHERE: W = 1

$$K_L = \frac{34.7 \times 12 \times 10^6}{4.625} = 90.03 \times 10^6 \text{ Lb/In}$$

$$K_R = \frac{39.075 \times 12 \times 10^6}{4.625} = 101.38 \times 10^6 \text{ Lb/In}$$

} Springs are in parallel

$$K_3 = K_L + K_R = 90.03 \times 10^6 \text{ Lb/In} + 101.38 \times 10^6 \text{ Lb/In} = 191.41 \times 10^6 \text{ Lb/In}$$

THREE MASS VERTICAL RUDDER SYSTEM MODEL

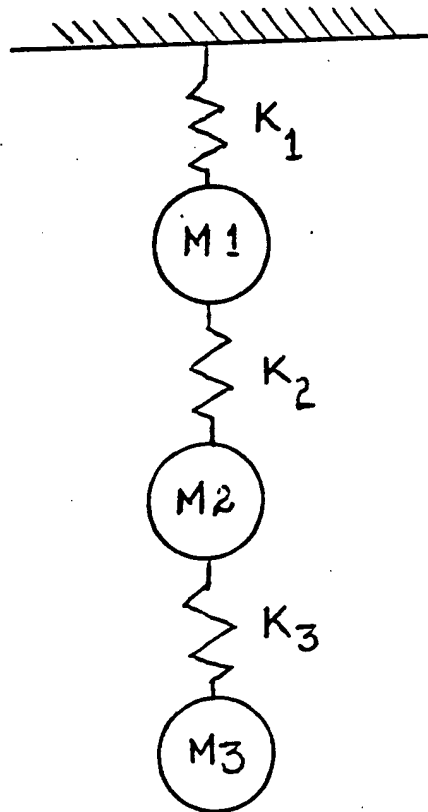

$$\begin{aligned} M_1 &= 39.752 \text{ lb sec}^2/\text{in} \\ M_2 &= 19.205 \text{ lb sec}^2/\text{in} \\ M_3 &= 29.793 \text{ lb sec}^2/\text{in} \end{aligned}$$

$$\begin{aligned} K_1 &= 268.71 \times 10^6 \text{ lb/in} \\ K_2 &= 64.46 \times 10^6 \text{ lb/in} \\ K_3 &= 191.41 \times 10^6 \text{ lb/in} \end{aligned}$$

INFLUENCE COEFFICIENTS

$$\delta_{11}, \delta_{12}, \delta_{13} = \frac{1}{K_1}$$

$$\delta_{22}, \delta_{23} = \frac{1}{K_1} + \frac{1}{K_2}$$

$$\delta_{33} = \frac{1}{K_1} + \frac{1}{K_2} + \frac{1}{K_3}$$

INFLUENCE COEFFICIENT MATRIX

$$\frac{1}{10^6} \begin{bmatrix} .003721 & .003721 & .003721 \\ .003721 & .019234 & .019234 \\ .003721 & .019234 & .024458 \end{bmatrix}$$

RUN NO....1... OF...1.....

DATE..12/3/70....

SHIP..Guide.....

EQUIPMENT..Rudder system.....

SHOCK DIRECTION; VERT.^X... ATHW.... F/A....

INPUT; DECK.^X.. HULL.... ELAST.^X.. ELAST-PLAST....

ANALYST..J.E.Davis.....

INPUT MASS VALUES

MASS NO	MASS	WEIGHT-LBS
1	39.782	15355.9
2	19.205	7413.13
3	29.793	11500.1

INPUT STIFFNESS MATRIX

3.3317E+8	-54460000	0
-54460000	2.5537E+8	-1.9141E+8
0	-1.9141E+8	1.9141E+8

MODE NUMBER 1

FREQUENCY = 965.814 RAD/SEC 153.75 CPS

PARTICIPATION FACTOR = 1.18603
EFFECTIVE MASS = 63.5876
EFFECTIVE WEIGHT = 24.5448 KIPS
PERCENT MODAL EFF WEIGHT = 71.6238
TOTAL PERCENT EFF WEIGHT = 71.6238

V = 35.893 IN/SEC (89.8081 G'S) A = 24.3028 G'S

MASS NO	MODE SHAPE	FORCE LBS	DISPL IN	ACCEL
1	0.136114	62376.9	2.21989E-3	5.36453
2	0.85481	182652.	1.01959E-2	24.639
3	1	331478.	1.19276E-2	28.824

MODE NUMBER 2

FREQUENCY = 2870.56 RAD/SEC 456.972 CPS

PARTICIPATION FACTOR = 0.757363
EFFECTIVE MASS = 25.0237
EFFECTIVE WEIGHT = 9.55914 KIPS
PERCENT MODAL EFF WEIGHT = 28.1862
TOTAL PERCENT EFF WEIGHT = 99.8099

V = 41.4949 IN/SEC (308.584 G'S) A = 41.6554 G'S

MASS NO	MODE SHAPE	FORCE LBS	DISPL IN	ACCEL
1	1	490847.	1.49736E-3	31.9648
2	0.083175	19709.1	1.24543E-4	2.65867
3	-0.294345	-108201.	-4.4074E-4	-9.40359

MODE NUMBER 3

FREQUENCY = 4353.13 RAD/SEC 692.986 CPS

PARTICIPATION FACTOR = 7.75597E-2
EFFECTIVE MASS = 0.163735
EFFECTIVE WEIGHT = 5.51315E-2 KIPS
PERCENT MODAL EFF WEIGHT = 0.19006
TOTAL PERCENT EFF WEIGHT = 100.

V = 59.6775 IN/SEC (673.019 G'S) A = 123.207 G'S

MASS NO	MODE SHAPE	FORCE LBS	DISPL IN	ACCEL
1	0.153225	22513.1	2.98639E-5	1.46503
2	-1.	-70930.5	-1.94902E-4	-9.55324
3	0.512944	56442.2	9.99739E-5	4.90797

MODAL EFFECTIVE WEIGHTS

MODE NO	FREQ-CPS	WEIGHT	PERCENT	TOT PCT
1	153.75	24544.8	71.8238	71.8238
2	456.972	9659.14	28.1352	99.8099
3	692.986	65.1318	0.19006	100.

TOTAL WEIGHT = 34269.1

NRL SUM OF DEFLECTIONS (BASED ON 2 MODES)
OUT OF DATA IN 1415

TYPICAL EXAMPLES OF STRESS ANALYSIS DEVELOPED FROM
THE VERTICAL DYNAMIC ANALYSIS

Stress Analysis for Upper Bearing Housing Bolts
(See Sketch 1 for Bolt Details)

No. of Bolts = 18

1½" Dia., Grade 8, Elastic Proof Stress = 120,000 PSI

Bolt Stress Area = 0.969 IN²

Mode 1 Forces =	82376.9#				
	182652.0#				
	<u>331478.0#</u>				
	596506.9#				
		$\frac{P}{A}$	=	$\frac{596506.9}{(18) 0.969}$	= 34199.45 PSI

Mode 2 Forces =	490847.0#				
	19709.1#				
	<u>- 108201.0#</u>				
	402355.1#				
		$\frac{P}{A}$	=	$\frac{402355.1}{(18) 0.969}$	= <u>23068.17 PSI</u>
		Tensile Stress Per Bolt=57268 PSI			

Direct Shear Stress In Carrier Key

Allowable Shear Stress = 19,800 PSI
Minimum Shear Area Of Carrier Key = 34.7 IN²

Force On Mass 3:

Mode 1 =	331478.0#				
		$\frac{P}{A}$	=	$\frac{331478.0}{34.7}$	= 9552.68 PSI

Mode 2 =	108201.0#				
		$\frac{P}{A}$	=	$\frac{108201.0}{34.7}$	= <u>3118.18 PSI</u>

Shear Stress					
		=	12671	PSI	

There are certain simplifications in most Rudder System shock analyses that require some explanation. Figure 2, Page 6 of this Report indicates an offset of 21.8 inches from the stock centerline for Mass No. 1.

An acceptable procedure for calculating the influence of offset masses may be found in Bureau of Ships Design Data Sheet DDS 9110-7, Design of foundations and other structures to resist shock loadings, Pages 26 through 36.

In most cases it is unnecessary to complicate the vertical shock analysis of a rudder system with a two-dimensional approach. Usually the significant forces and deflections can be satisfactorily calculated with the simple one-dimensional model illustrated in this Appendix.

In the model problem illustrated in this Appendix the simplifying assumption was made that the centroid of mass 1 is located on the centerline of the rudder stock. As the results of this simplification, the bending moment in the rudder stock and the horizontal reaction forces acting at the upper and lower bearings were not calculated. If these forces were calculated it would be found that the horizontal reaction force is 57,390 pounds. This means that the shear force per bolt on the upper bearing housing bolts is 3,188 pounds, or a shear stress of 5,484 psi per bolt. From the stress analysis on the previous page the tensile bolt stress under vertical shock was calculated as 57,268 psi. The combined stress would therefore be 57,775 psi, an increase in stress of less than one percent. This combined stress represents only 50 percent of the allowable bolt stress, which is ample justification for making the simplifying assumption. On the other hand, if the tensile stress in the bolts had been found to be very near the allowable stress, the system should be remodeled to consider the effects of the offset of mass no.1.

The bending moment in the rudder stock due to offset masses in vertical rudder system models will usually be less than the bending moment in the rudder stock due to athwartship shock. Thus the maximum bending stress in the rudder stock and the maximum radial load on the upper and lower bearings will usually be calculated from the athwartship shock model.

APPENDIX II

SAMPLE ATHWARTSHIPS MODEL AND DYNAMIC SHOCK ANALYSIS
FOR A RUDDER SYSTEM

A Method for Calculating the Added Mass for Entrained Water

TYPICAL MASS DISTRIBUTION FOR A 5 MASS ATHWARTSHIP RUDDER SYSTEM MODEL

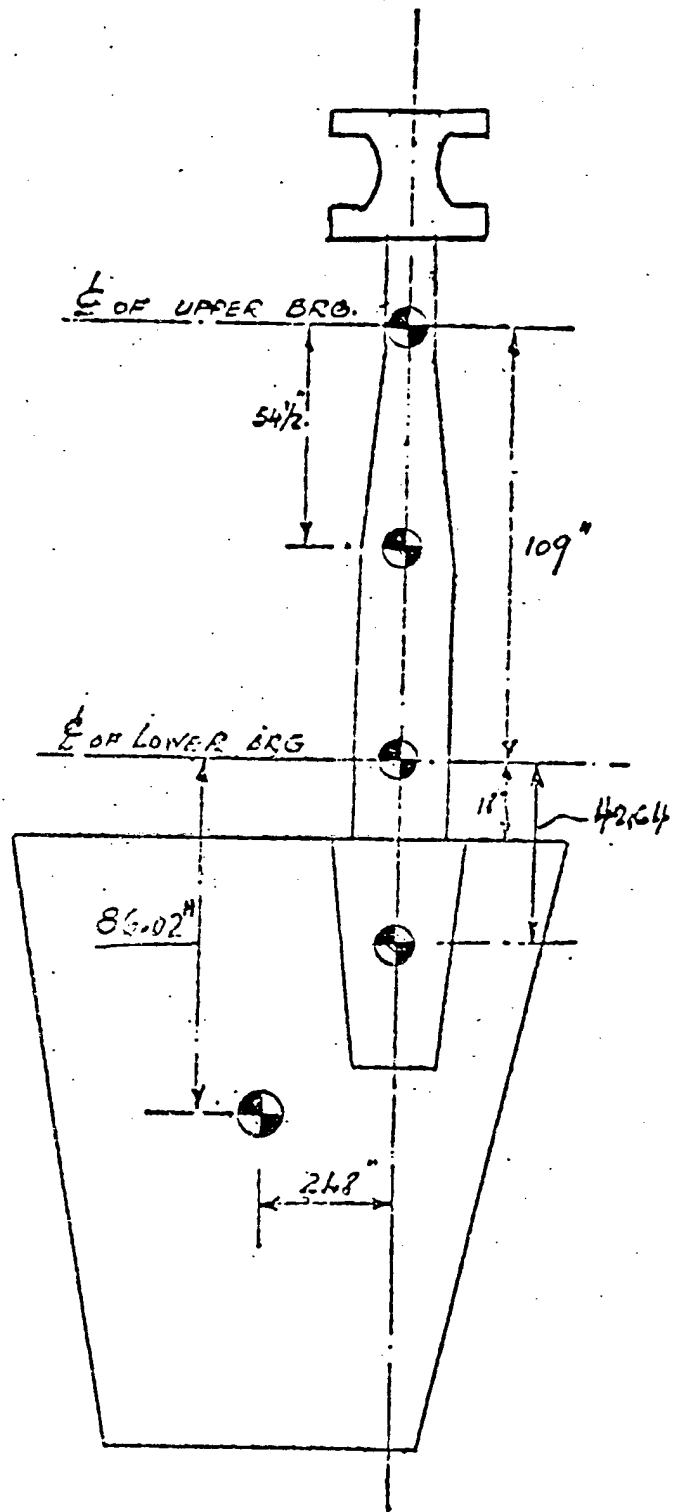
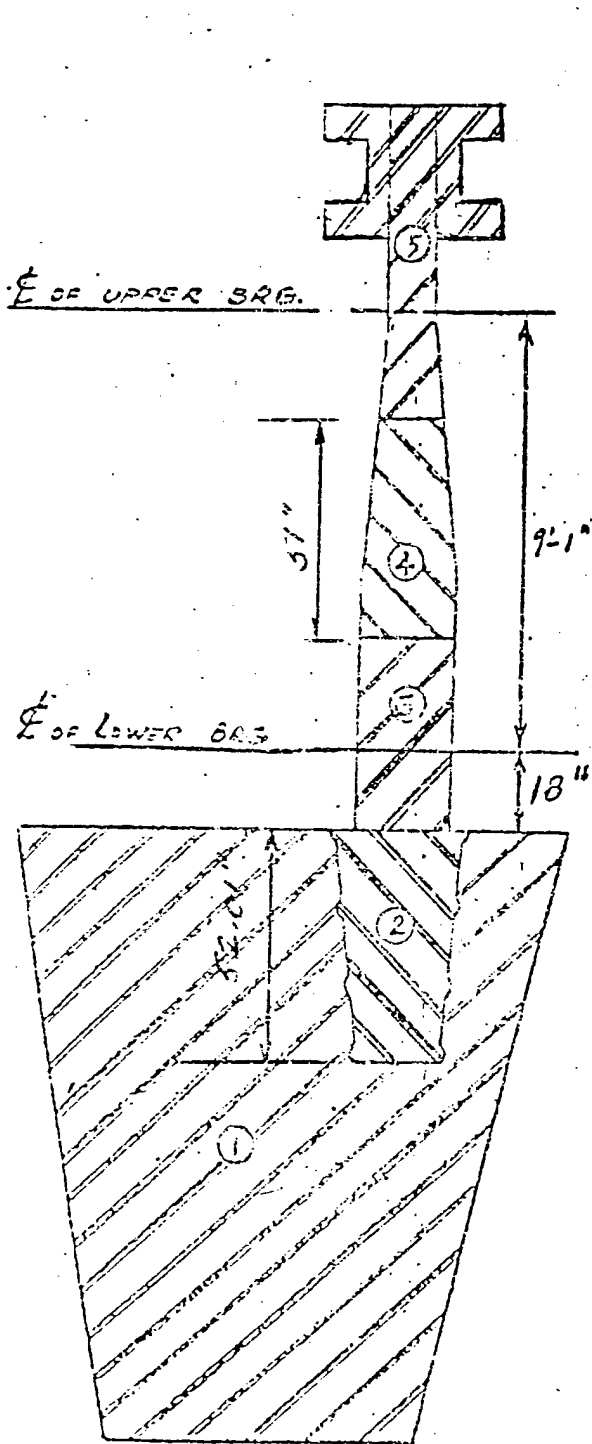

ATHWARTSHIP RUDDER SYSTEM COMPONENT WEIGHTS

<u>ITEM</u>	<u>WT. (Pounds)</u>
Rudder Stock	14,826
Crosshead	5,200
Upper Bearing	500
Upper Bearing Housing	1,785
Carrier Ring, Retainer and Seal	143
Lower Bearing and Lower Bearing Housing	1,000 *
Rudder and Rudder Hub Casting	11,500
Upper Bearing Foundation	630
Lower Bearing Foundation	<u>1,000 *</u>
TOTAL SYSTEM WEIGHT-----	36,584

* It should be noted that there is a difference between the Vertical and Athwartship system weights. The difference is due to the fact that the lower bearing, lower bearing housing and lower bearing housing foundation do not participate in the Vertical system shock analysis.

ATHWARTSHIP MODEL MASS DISTRIBUTION

Mass No. 1 Weight of rudder (excluding rudder hub casting and rudder stock)

$$5,800 \text{ lbs} \quad \text{Mass} = \frac{5800}{386} = 15.025 \text{ lbs sec}^2/\text{in.}$$

Mass No. 2 Rudder hub casting plus 52.01 in of lower rudder stock.

$$5,700 + 3,000 = 8,700 \text{ lbs} \\ \text{Mass} = \frac{8700}{386} = 22.538 \text{ lbs sec}^2/\text{in.}$$

Mass No. 3 Rudder stock in way of lower bearing, lower bearing, lower bearing housing and $\frac{1}{2}$ lower bearing foundation

$$5661 + 1000 + 500 = 7,161 \text{ lbs} \quad \text{Mass} = \frac{7161}{386} = 18.552 \text{ lbs sec}^2/\text{in.}$$

Mass No. 4 51 inch length of rudder stock between the upper and lower bearings

$$3,785 \text{ lbs.} \quad \text{Mass} = \frac{3785}{386} = 9.806 \text{ lbs. sec}^2/\text{in.}$$

Mass No. 5 Upper portion of rudder stock, cross head, carrier ring, retainer and seal, upper bearing, upper bearing housing and $\frac{1}{2}$ upper foundation

$$2380 + 5200 + 500 + 143 + 1785 + 315 = 10,323 \text{ lbs} \quad \text{Mass} = \frac{10323}{386} = 26.743 \text{ lbs sec}^2/\text{in.}$$

Total model weight-----35,769 lbs.

Total system weight-----36,584 lbs.

Percentage of system weight modeled-----97.8%

LOWER BEARING SUPPORT

Assumption- Bearing is supported by lower bearing housing which is held rigid by shell and supporting structure.
 Calculate deflection at point C, P=1000 kips.

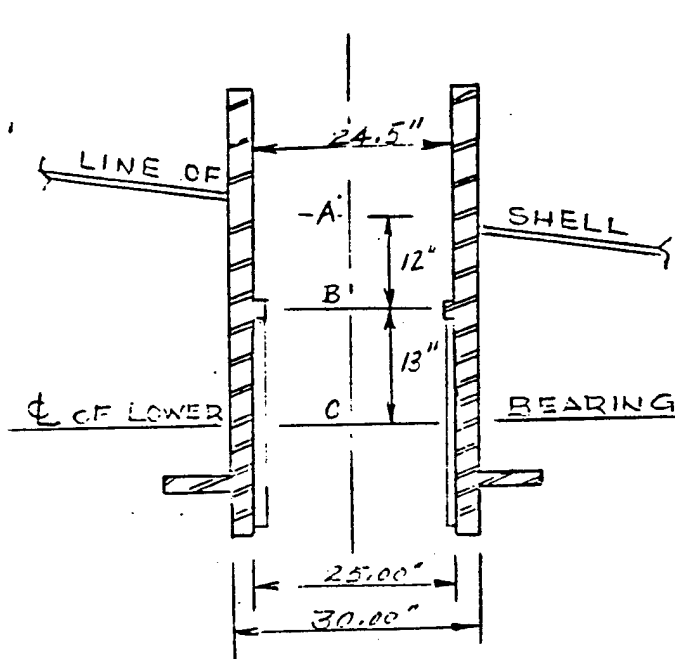

LOWER BEARING HOUSING

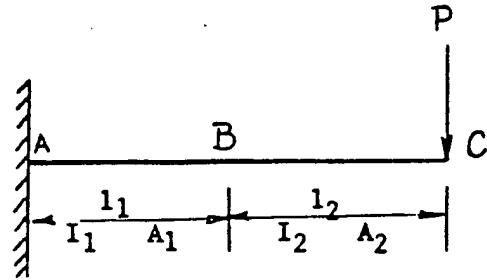

SPAN A-B

$$l_1 = 12''$$

$$I_1 = .049087(D^4 - d_t^4) = 22077 \text{in}^4$$

SPAN B-C

$$l_2 = 13''$$

$$I_2 = 20588 \text{in}^4$$

BY SUPERPOSITION METHOD

SPAN A-B Find deflection and slope due to load and moment and shear deflection.

SPAN B-C Find deflection and slope due to load and deflection due to slope at point B. Also find shear deflection.

LOWER BEARING HOUSING CONT'D.



- $P = 1000$ Kips
 $M = P l_2 = 1000 \times 13 = 13000$ in-k
 δ_1 = Deflection due to load P
 δ_2 = Deflection due to moment M
 δ_3 = Shear deflection

$$\delta_1 = \frac{P l_1^3}{3 E I_1} = \frac{1000 \times 12^3}{3 \times 30 \times 10^3 \times 22077} = 0.87 \times 10^{-3} \text{ in}$$

$$\delta_2 = \frac{M l_1^2}{2 E I_1} = \frac{13000 \times 12^2}{2 \times 30 \times 10^3 \times 22077} = 1.413 \times 10^{-3} \text{ in}$$

$$\delta_3 = \frac{V Q l_1}{I b G} = \frac{1000 (30^3 - 24.5^3) \times 12}{12 \times 22077 \times 5.5 \times 12 \times 10^3} = 8.438 \times 10^{-3} \text{ in}$$

$$\text{Slope due to } P = \frac{P l_1^2}{2 E I_1} = \frac{1000 \times 12^2}{2 \times 30 \times 10^3 \times 22077} = .1087 \times 10^{-3}$$

$$\text{Slope due to } M = \frac{M l_1}{E I_1} = \frac{13000 \times 12}{30 \times 10^3 \times 22077} = .2355 \times 10^{-3}$$

$$\text{Total slope} = .3442 \times 10^{-3}$$

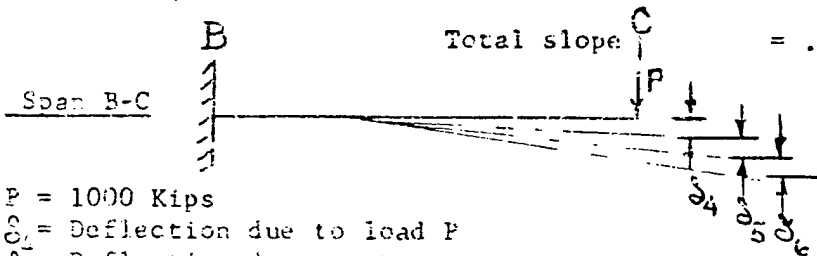

- $P = 1000$ Kips
 δ_4 = Deflection due to load P
 δ_5 = Deflection due to shear
 δ_6 = Deflection due to slope in span A-B

$$\delta_4 = \frac{P l_2^3}{3 E I_2} = \frac{1000 \times 13^3}{3 \times 30 \times 10^3 \times 20588} = 1.1857 \times 10^{-3} \text{ in}$$

$$\delta_5 = \frac{V Q l_2}{I b G} = \frac{1000 \times (30^3 - 25^3) \times 13}{12 \times 20588 \times 5 \times 12 \times 10^3} = 9.9758 \times 10^{-3} \text{ in}$$

$$\delta_6 = \text{Slope} \times l_2 = .3442 \times 10^{-3} \times 13 = 4.4746 \times 10^{-3} \text{ in}$$

$$\text{Total deflection} = \sum \delta = (.87 + 1.413 + 1.1857 + 8.438 + 9.9758 + 4.4746) \times 10^{-3} = 26.3571 \times 10^{-3} \text{ in/1000 Kips}$$

$$K = \frac{10^6 \times 1000}{26.3571} = \underline{\underline{37.94 \times 10^6 \text{ lb/in}}}$$

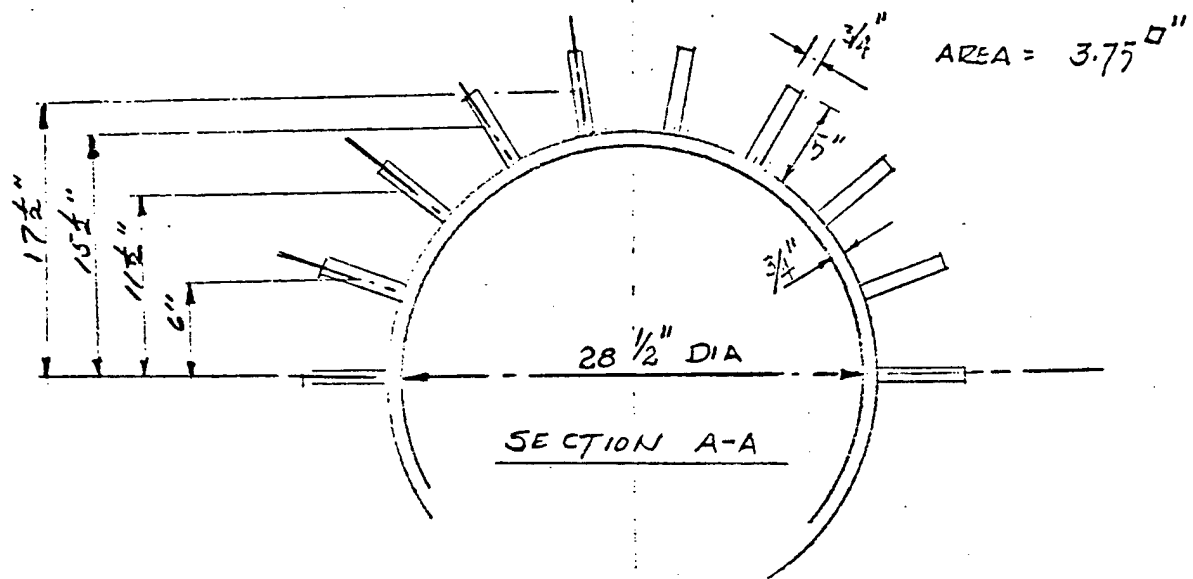
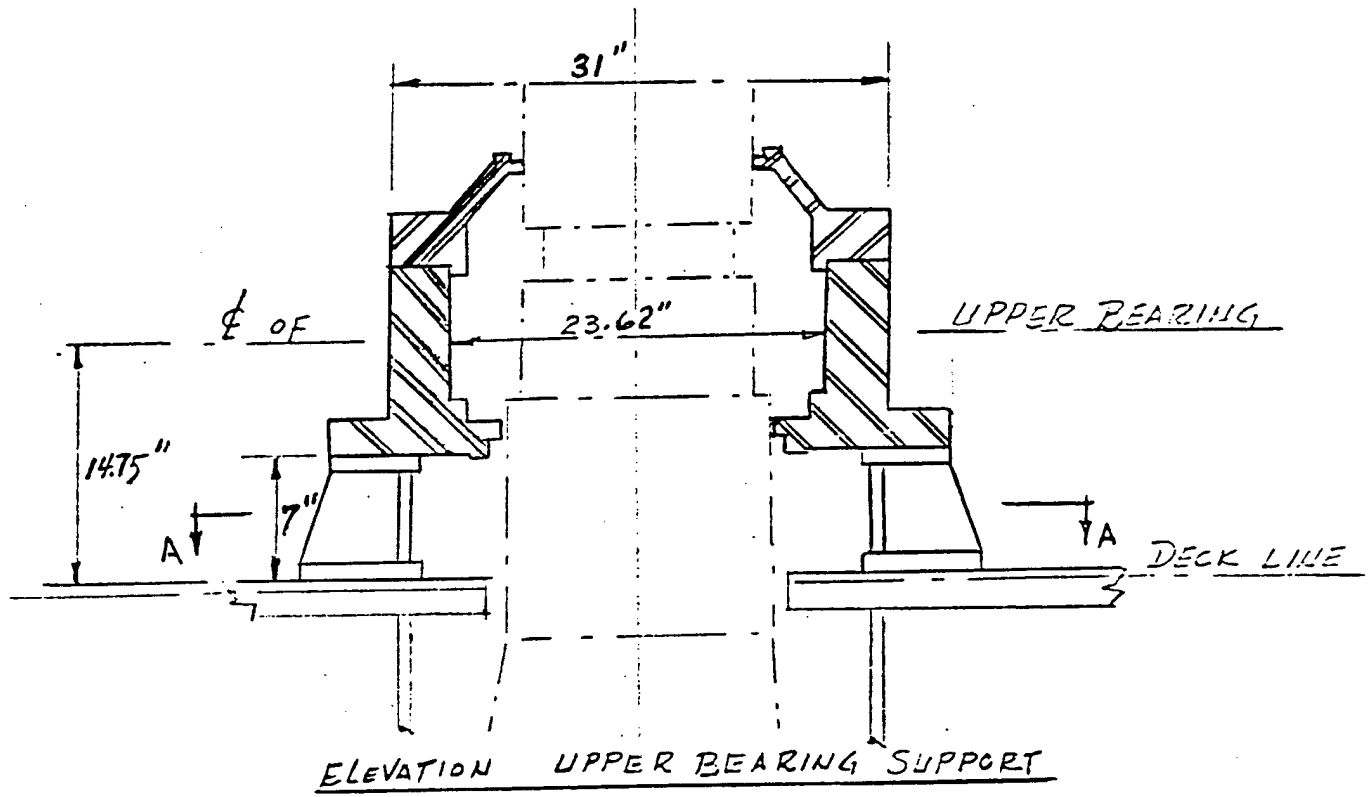

UPPER BEARING SUPPORT

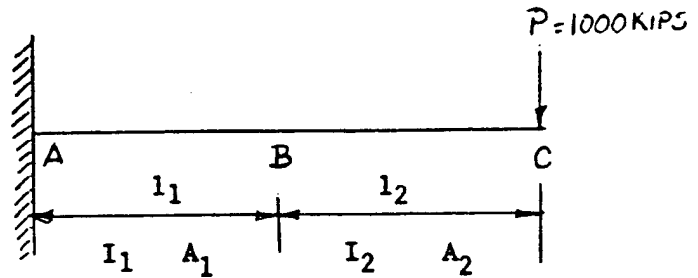
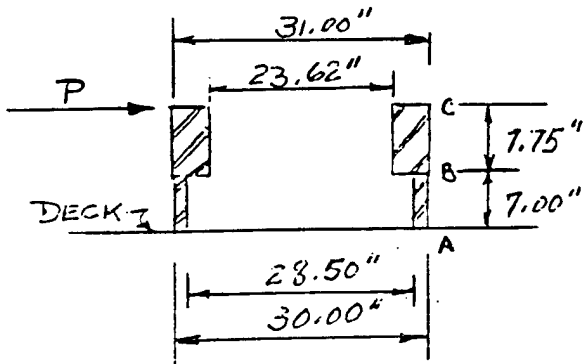

SIMPLIFIED MODEL

MEMBER PROPERTIES

SPAN A-B

$$l_1 = 7''$$

$$I_1 = 18097 \text{ in}^4$$

$$b_1 = 1.5 \text{ in}$$

$$Q_1 = 700 \text{ in}^3$$

SPAN B-C

$$l_2 = 7.75''$$

$$I_2 = 30058 \text{ in}^4$$

$$b_2 = 7.38 \text{ in}$$

$$Q_2 = 1384 \text{ in}^3$$

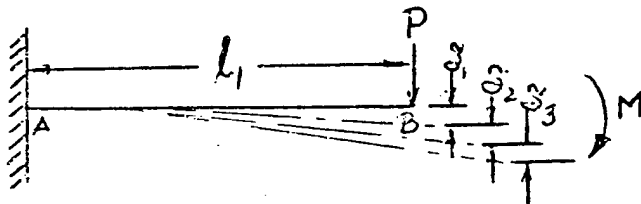

$$P = 1000 \text{ Kips}$$

$$M = Pl_2 = 1000 \times 7.75 = 7750 \text{ in-k}$$

$$\delta_1 = \text{Due to load } P = \frac{Pl_1^3}{3EI_1} = \frac{1000 \times 7^3}{3 \times 30 \times 10^3 \times 18097} = 0.2106 \times 10^{-3} \text{ in}$$

$$\delta_2 = \text{Due to } M = \frac{Ml_1}{2EI_1} = \frac{7750 \times 7}{2 \times 30 \times 10^3 \times 18097} = 0.3497 \times 10^{-3} \text{ in}$$

$$\delta_3 = \text{Due to shear} = \frac{VQl_1}{I_1 b_1 G} = \frac{1000 \times 700 \times 7}{18097 \times 1.5 \times 12 \times 10^3} = 15.0424 \times 10^{-3} \text{ in}$$

$$\text{SLOPES}$$

$$\text{Due to } P = \frac{Pl_1^2}{2EI_1} = \frac{1000 \times 7^2}{2 \times 30 \times 10^3 \times 18097} = 0.0451 \times 10^{-3}$$

$$\text{Due to } M = \frac{Ml_1}{EI_1} = \frac{7750 \times 7}{30 \times 10^3 \times 18097} = 0.0999 \times 10^{-3}$$

$$\text{Total slope} = 0.1450 \times 10^{-3}$$

UPPER BEARING SUPPORT CONT'D



$P = 1000 \text{ Kips}$
 $\delta_4 = \text{Deflection due to } P = \frac{Pl_2^3}{3EI_2} = \frac{1000 \times 7.75^3}{3 \times 30 \times 10^3 \times 30058} = 0.1721 \times 10^{-3} \text{ in}$
 $\delta_5 = \text{Deflection due to shear} = \frac{VQ_2 l_2}{I_2 b_2 G} = \frac{1000 \times 1384 \times 7.75}{30058 \times 7.38 \times 12 \times 10^3} = 4.0294 \times 10^{-3} \text{ in}$
 $\delta_6 = \text{Deflection due to slope} = \text{Slope} \times l_2 = 0.1450 \times 10^{-3} \times 7.75 = 1.1238 \times 10^{-3} \text{ in}$
 in span A-B.

Total deflection = $(0.1721 + 4.0294 + 1.1238) \times 10^{-3} = 5.3253 \times 10^{-3}$

TOTAL DEFLECTION - Span A-B + Span B-C = $15.6027 + 5.3253 = 20.9280 \times 10^{-3} \text{ in}/1000^{\text{K}}$

K for UPPER BEARING = $\frac{1000 \times 10^6}{20.928} = \underline{\underline{47.78 \times 10^6 \text{ lb/in}}}$

MATHEMATICAL MODEL FOR ATHWARTSHIP SHOCK DIRECTION

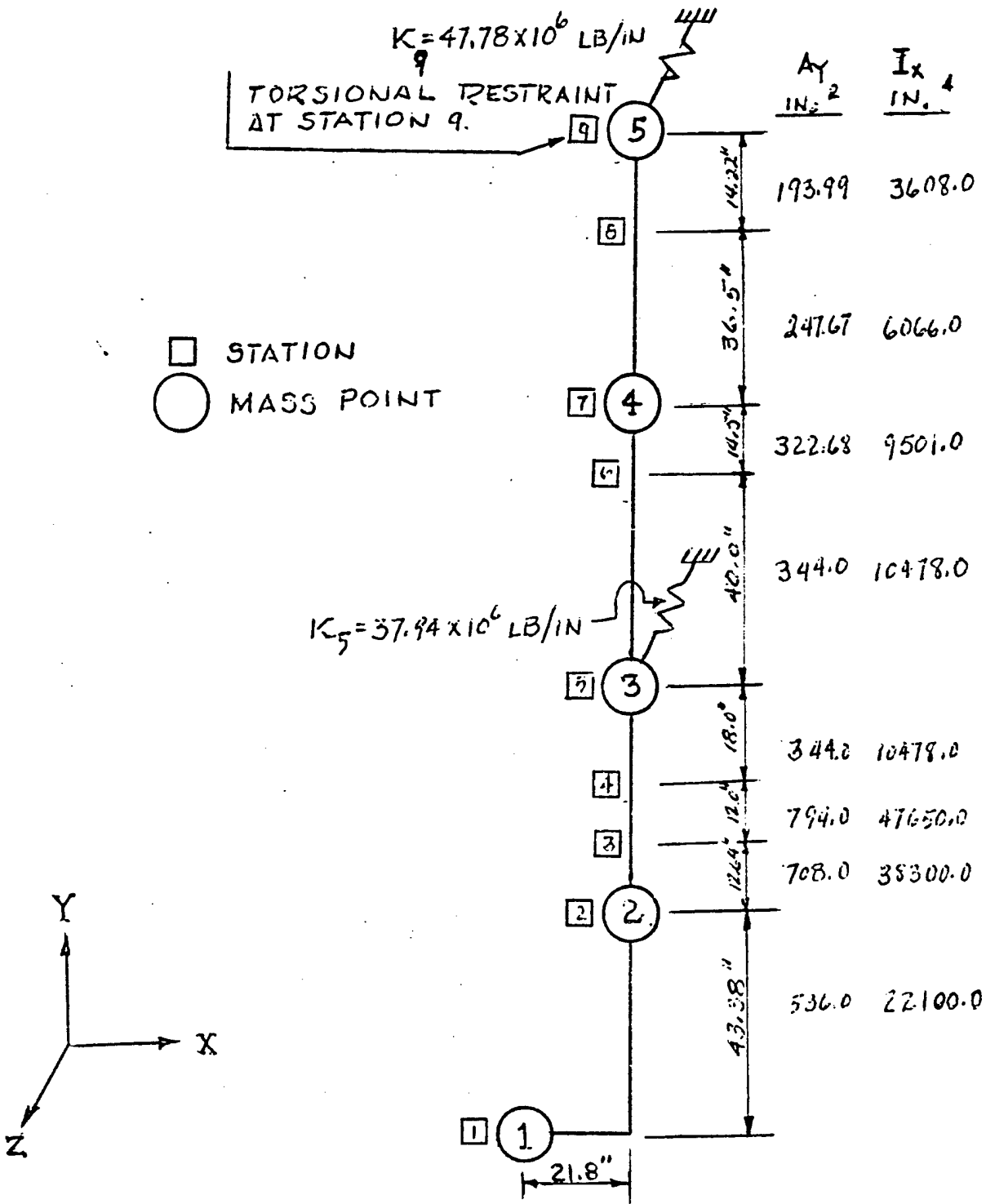

FEAM1

00:03FST

11/02/70

RUN NO...1... OF...1....

DATE..11-2-70.....

SHIP.GUIDE.MANUAL.....

EQUIPMENT.RUDDER.SYSTEM.....

SHOCK DIRECTION: VERT.... ATHW.V.. F/A....

INPUT. DECK.... HULL.V.. ELAST.V.. ELAST-PLAST....

ANALYST.J.E.DAVIS.....

DO YOU WANT THE MATRIX RESULT PRINTED? YES

WHICH ONE? STIFFNESS, INFLUENCE OR BOTH? INFLUENCE

INFLUENCE COEFFICIENT MATRIX

1.44904E-6	6.86672E-7	4.79803E-7	2.8985E-7	4.79054E-8
-2.0692E-7	-2.21839E-7	-1.01857E-7	-1.71104E-8	
6.86671E-7	3.48055E-7	2.49682E-7	1.57685E-7	3.70392E-8
-2.43308E-8	-1.03558E-7	-4.86938E-8	-3.4816E-9	
4.79802E-7	2.49682E-7	1.8263E-7	1.19175E-7	3.38727E-8
-5.15248E-8	-6.90934E-8	-3.32033E-8	-5.96735E-9	
2.8985E-7	1.57685E-7	1.19175E-7	3.26145E-8	3.08656E-8
-3.03799E-8	-3.63739E-8	-1.84971E-8	-3.58041E-9	
4.79056E-8	3.70388E-8	3.38725E-8	3.08655E-8	2.63575E-8
1.63375E-8	1.27053E-8	3.56209E-9	9.06474E-15	
-2.06291E-7	-9.43312E-8	-6.15252E-8	-3.03801E-8	1.63373E-8
9.01199E-8	1.05412E-7	4.79964E-8	7.95643E-9	
-2.2184E-7	-1.03558E-7	-6.90937E-8	-3.63742E-8	1.27051E-8
1.05412E-7	1.19189E-7	5.85442E-8	1.08406E-8	
-1.01857E-7	-4.86939E-8	-3.32034E-8	-1.84979E-8	3.56201E-9
4.79064E-8	5.85442E-8	4.58845E-8	1.81008E-8	
-1.71104E-8	-8.48162E-9	-5.96737E-9	-3.58042E-9	-1.21731E-14
7.95642E-9	1.08406E-8	1.81008E-8	2.08293E-8	

DO YOU WANT TO TEST YOUR INFLUENCE MATRIX TO DETERMINE IF IT IS POSITIVE DEFINITE? YES.

THERE ARE NO ERRORS IN YOUR INFLUENCE MATRIX. IT IS POSITIVE DEFINITE.

DO YOU WANT TO COMPUTE THE FREQUENCIES AND MODE SHAPES? YES

NUMBER OF FINAL ITERATIONS = 33

TRACE OF DYNAMIC MATRIX= 1.28069E+7
SUM OF EIGENVALUES= 12806890

DETERMINANT OF DYNAMIC MATRIX= 2.85498E-2 X (2.01904E+6)** 5
PRODUCT OF EIGENVALUES= 2.85498E-2 X (2.01904E+6)** 5

ORTHOGONALITY CHECK OF MODE SHAPES

LARGEST ABSOLUTE DEVIATION OF
DIAGONAL ELEMENTS FROM 1= 3.20375E-7

LARGEST ABSOLUTE DEVIATION OF THE
OFF-DIAGONAL ELEMENTS FROM 0= 5.97019E-8

MODAL EFFECTIVE WEIGHTS

MODE NO	PARTICIPATION FACTOR	WEIGHT KIPS	MASS LBS-SEC**2/IN	PERCENT	TOT PERCENT
1	-1.20382	11.4922	29.7696	32.1264	32.1264
2	1.73185	17.3753	45.009	48.5723	80.6986
3	0.252717	1.22017	3.16074	3.41096	84.1096
4	-0.57901	5.40397	13.9985	15.1067	99.2163
5	0.141536	0.280344	0.726205	0.783697	100.

MODE NUMBER 1

FREQUENCY = 183.746 RAD/SEC 29.251 CPS

PARTICIPATION FACTOR = -1.20382
 EFFECTIVE MASS = 29.7696
 EFFECTIVE WEIGHT = 11.4911 KIPS
 PERCENT OF WEIGHT IN THIS MODE 32.1264
 PERCENT OF TOTAL WT. USED INCLUDING THIS MODE 32.1264
 V = 32.2323 IN/SEC (15.3436 G'S) A = 30.0938 G'S

MASS NO	MODE SHAPE	FORCE LBS	DISPL IN	ACCEL
1	-1	107125.	0.211174	18.471
2	-0.482461	77527.3	0.101883	8.91153
3	-3.72669E-2	5003.73	7.99652E-3	0.699439
4	0.156554	-10945.4	-3.30602E-2	-2.69171
5	1.25935E-2	-2401.23	-2.65943E-3	-0.232614

MODE NUMBER 2

FREQUENCY = 975.331 RAD/SEC 155.255 CPS

PARTICIPATION FACTOR = 1.73135
 EFFECTIVE MASS = 45.009
 EFFECTIVE WEIGHT = 17.3735 KIPS
 PERCENT OF WEIGHT IN THIS MODE 48.5723
 PERCENT OF TOTAL WT. USED INCLUDING THIS MODE 80.6987
 V = 30.1692 IN/SEC (75.2093 G'S) A = 23.6027 G'S

MASS NO	MODE SHAPE	FORCE LBS	DISPL IN	ACCEL
1	-5.32694E-2	-12628.5	-8.83551E-4	-2.17745
2	0.191738	63183.9	3.18026E-3	7.83753
3	0.438078	123233.	7.26617E-3	17.907
4	1	154721.	1.65265E-2	40.8762
5	0.169569	71550.3	2.81255E-3	6.93134

MODE NUMBER 3

FREQUENCY = 1310.8 RAD/SEC 208.67 CPS
 PARTICIPATION FACTOR = 0.252717
 EFFECTIVE MASS = 3.16073
 EFFECTIVE WEIGHT = 1.22004 KIPS
 PERCENT OF WEIGHT IN THIS MODE 3.41096
 PERCENT OF TOTAL WT. USED INCLUDING THIS MODE 84.1096
 V = 43.9445 IN/SEC (149.229 G'S) A = 78.556 G'S

MASS NO	MODE SHAPE	FORCE LBS	DISPL IN	ACCEL
1	0.527394	60722.7	2.35214E-3	10.4701
2	-0.59416	-102517.	-2.64991E-3	-11.7955
3	-0.69295	-98513.1	-3.09051E-3	-13.7568
4	0.416753	31316.4	1.25869E-3	8.27357
5	1	204933.	4.45993E-3	19.8524

NRL SUM OF DEFLECTIONS (BASED ON 3 MODES)

MASS NO 1 -FIXED BASE = 0.213687 INCHES
 MASS NO 2 -FIXED BASE = 0.106923 INCHES
 MASS NO 3 -FIXED BASE = 1.58926E-2 INCHES
 MASS NO 4 -FIXED BASE = 4.27595E-2 INCHES
 MASS NO 5 -FIXED BASE = 8.33072E-3 INCHES

MOMENT AT EACH STATION IN EACH MODE

<u>MODE #1</u>	<u>MODE #2</u>	<u>MODE#3</u>	<u>STATION</u>
0	0	0	1
-4.64708D+6	547824.	-2.63415E+6	2
-5.98109E+6	-154395.	-2.10461E+6	3
-9.19692E+6	-821051.	-1.50188E+6	4
-1.25207E+7	-1.82106E+5	-847778.	5
-7.07158E+6	1.85455E+6	78350.2	6
-5.32254E+6	3.18695E+6	414085.	7
-1.47535E+6	893524.	116138.	8
0	0	0	9

..... NRL SUM FOR 3 MODES

<u>STATION</u>	<u>REACTION</u>	<u>MOMENT</u>	<u>STRESS</u>
1	0	0	0
2	0	7.3376E+6	3320.18
3	0	9.09135E+6	2522.08
4	0	1.0997E+7	3144.46
5	602966.	1.45294E+7	23053.2
6	0	9.82778E+6	14772.6
7	0	9.53628E+6	9033.42
8	0	2.37749E+6	3233.48
9	398042.	0.	0

TORSIONAL MOMENT

<u>FORCE @ STA.#1</u>	<u>DISTANCE</u>	<u>MOMENT (IN-LBS)</u>	<u>MODE NO.</u>
107125.0	21.8	2335325.	1
12628.5	21.8	275301.3	2
60722.7	21.8	1323754.8	3

SHOCK STRESS ANALYSIS

RUDDER STOCK IN WAY OF CARRIER RING

Material: Steel Forging - Tensile Yield = 65,000 PSI

O.D. = 12 IN. A = 93.46 IN² J = 1974 IN⁴

I.D. = 5 IN.

Loading	Mode 1	Mode 2	Mode 3
Torque (IN-LBS)	2335325	275301.3	1323754.8

STRESS

Mode 1 $\frac{2335325 \times 6''}{1974} = 7098 \text{ PSI}$

Mode 2 $\frac{275301.3 \times 6''}{1974} = 837 \text{ PSI}$

Mode 3 $\frac{1323754.8 \times 6''}{1974} = 4024 \text{ PSI}$

$$S_T = 7098 + \sqrt{(4024)^2 + (837)^2} = 11208 \text{ PSI}$$

SHOCK STRESS ANALYSIS

RUDDER STOCK Q LOWER BEARING

STEEL FORGING: Tensile Yield = 65,000 PSI

O.D. = 21.5 IN A = 343.42 IN² J = 20916 IN⁴

I.D. = 5.0 IN

LOADING	<u>MODE 1</u>	<u>MODE 2</u>	<u>MODE 3</u>
TORQUE	2335325	275301.3	1323754.8
SHEAR	0	0	41894.3

<u>STRESS</u>	<u>TORQUE</u>	<u>SHEAR</u>
Mode 1	$\frac{2335325 \times 10.75}{20916} = 1200.3 \text{ PSI}$	0
Mode 2	$\frac{275301.3 \times 10.75}{20916} = 141.5 \text{ PSI}$	0
Mode 3	$\frac{1323754.8 \times 10.75}{20916} = 680.4 \text{ PSI}$	198.6 PSI

$$S_t = 1200.3 + \sqrt{(680.4)^2 + (141.5)^2} = 1895.3 \text{ PSI}$$

$$S_s = 198.6 \text{ PSI}$$

$$S_b = 23053.2 \text{ PSI (STRESS AT STATION 5) (See page II-15)}$$

$$\text{PRINCIPAL STRESS} = 11526.6 + \sqrt{(11526.6)^2 + (1895.3)^2} = 23208 \text{ PSI}$$

SHOCK STRESS ANALYSIS

RUDDER STOCK 15" BELOW Q_L OF UPPER BEARING

STEEL FORGING: Tensile Yield = 65,000 PSI

O.D. = 16.56 IN A = 193.99 IN² J = 7216 IN⁴

I.D. = 5.00 IN

BENDING STRESS AT STATION 8 = 3233 PSI

LOADING	<u>MODE 1</u>	<u>MODE 2</u>	<u>MODE 3</u>
TORQUE	2335325	275301.3	1323754.8
SHEAR	124,666	62832	8,163

<u>STRESS</u>	<u>TORQUE</u>	<u>SHEAR</u>
Mode 1	$\frac{2335325 \times 8.3}{7216} = 2686 \text{ PSI}$	$\frac{4 \times 124666}{3 \times 193.99} \left[1 + \frac{16.56 \times 5}{16.56^2 + 5^2} \right] = 867 \text{ PSI}$
Mode 2	$\frac{275301.3 \times 8.3}{7216} = 317 \text{ PSI}$	$\frac{4 \times 62832}{3 \times 193.99} \left[1 + \frac{16.56 \times 5}{16.56^2 + 5^2} \right] = 437 \text{ PSI}$
Mode 3	$\frac{1323754.8 \times 8.3}{7216} = 1523 \text{ PSI}$	$\frac{4 \times 8,163}{3 \times 193.99} \left[1 + \frac{16.56 \times 5}{16.56^2 + 5^2} \right] = 57 \text{ PSI}$

$S_t = 3233 \text{ PSI}$ (From station 8, page II-15)

$$S_t = 2686 + \sqrt{(1523)^2 + (317)^2} = 4242 \text{ PSI}$$

$$S_s = 867 + \sqrt{(437)^2 + (57)^2} = 1308 \text{ PSI}$$

$$\text{PRINCIPAL STRESS} = 1617 + \sqrt{(1617)^2 + (4242)^2} = 6156 \text{ PSI}$$

Shock Stress Analysis

Bolt Stress in Upper Bearing Housing

No. of Bolts resisting shear load = 18
1 $\frac{1}{4}$ " Dia., Grade 8, Elastic Proof Stress = 120,000 PSI
Bolt shear stress area = 0.969 In² x 0.60 = 0.581 In²
Shear Force on Bolts is equal to the reaction Force at Station 9. P = 398042 Lbs.

$$\frac{P}{A} = \frac{398042}{(18) 0.581} = 38053.7 \text{ PSI}$$

Stress in Lower Bearing Housing

Material: Steel Casting; Tensile yield = 30,000 PSI
I.D = 24.5 In A = 235.45 In² J = 44154 In⁴

$$\text{O.D} = 30 \text{ In} \quad I = 22077 \text{ In}^4$$

Bending moment = Reaction force at station 5 times the distance between the ϕ . of lower bearing and the shell support of the lower bearing housing.

$$M_b = 602966 \text{ Lbs} \times 25 \text{ In} = 15,074,150 \text{ In-Lbs}$$

$$S_b = \frac{15074150 \times 15}{22077} = 10242 \text{ PSI}$$

$$S_s = \frac{4 \times 23153.4}{3 \times 235.45} \left[1 + \frac{30 \times 24.5}{30^2 + 24.5^2} \right] = 194 \text{ PSI}$$

ENTRAINED WATER IN THE ATHWARTSHIP SHOCK DIRECTION

When the added mass of entrained water is required to be included in a rudder assembly dynamic analysis, the following is an acceptable method of calculating the weight of the added mass:

1. Assume the rudder to be surrounded by a conic segment of water having the following characteristics:
 - a. Vertical axis considered perpendicular to the design base line.
 - b. Diameter at top has the same dimension as the chord length at the top of the rudder.
 - c. Diameter at bottom has the same dimension as the chord length at the bottom of the rudder.
 - d. The height is the same dimension as the rudder span.
2. Calculate the weight of water equal to the volume of the truncated cone.
3. Calculate the weight of water equal to the rudder volume.
4. Subtract item 3 from item 2; the difference is the weight to be appropriately distributed.

The added mass of entrained water is negligible in the vertical and fore and aft shock directions and need not be considered.

APPENDIX III

SAMPLE SUMMARY SHEETS USING INFORMATION FROM APPENDIX I

DATE 2/12/70

MODEL DATA

SHIP: Guidance Manual

EQUIP: Rudder System

GRADE: A B

VENDOR: SupShip THREE

MOUNTING: DECK HULL SHELL

INPUT: ELASTIC ELASTIC PLASTIC

SHOCK DIRECTION: VERT ATHWART FORE/AFT

ELEMENT-NO.	WEIGHT -W _i	MASS-M _i	SPRING CONSTANT-K _i
1	15355.9	39.728	268.71 x 10 ⁶
2	7413.13	19.205	64.46 x 10 ⁶
3	11500.1	29.793	191.41 x 10 ⁶
4			
5			
6			
7			
8			
9			
10			
11			
12			
13			
14			
15			

INFLUENCE COEFFICIENT MATRIX

UNIT LOAD AT MASS NO.

	1	2	3	4	5	6	7	8	9	10
1	.003721	.003721	.003721							
2	.003721	.019234	.019234							
3	.003721	.019234	.024458							
4										
5										
6										
7										
8										
9										
10										

DEFLECTION AT MASS NO.

RESULTS

MODE	FREQUENCY		PARTICIPATION FACTOR	EFFECTIVE WEIGHT	INPUT (V) or (A)	TOTAL EFF. WT.	TOTAL % EFF. WT.
	RPS	CPS					
1	965.8	153.7	1.18603	24545	A=24.3(g's)	24545	71.6238
2	2870.5	456.9	0.767363	9659	A=41.65(g's)	34204	99.8099
3							
4							
5							
6							
7							
8							
9							
10							
11							
12							
13							
14							
15							
16							
17							
18							
19							
20							

M A S S	FREQUENCY (CPS)	153.75						456.972											
		MODE 1			MODE 2			MODE 3			MODE 4			MODE 5					
		F	G	X	F	G	X	F	G	X	F	G	X	F	G	X			
1	15355.9	82376.9	4.5	2.2×10^{-3}	4.5	490847	31.96	1.5	10^6										
2	7413.13	182652	24.6	1.02×10^{-2}	24.6	19709.1	2.66	1.2	10^6										
3	11500.1	331478	28.8	1.2×10^{-2}	28.8	-108201	-9.4	-4.4	10^6										
4																			
5																			
6																			
7																			
8																			
9																			
10																			
Σ	F (LBS.)	596506.9						402355.1											

F = FORCE: LBS G = ACCELERATION: g's X = DEFLECTION: INCHES

STRESS SUMMARY

	ITEM OR LOCATION	REF PAGE	MAXIMUM STRESS *	ALLOWABLE STRESS *	MATERIAL (SPEC & GRADE)
1	Upper Bearing Hse. Bolts	I-11	$S_t = 57.3\text{KSI}$	120KSI	MIL-B-857 Gr. M
2	Carrier Key	I-11	$S_s = 12.66\text{KSI}$	19.8KSI	MIL-S-22698 Gr. M
3					
4					
5					
6					
7					
8					
9					
10					
11					
12					
13					
14					
15					
16					
17					
18					
19					
20					

* INDICATE WHETHER TENSILE OR SHEAR STRESS