

TECHNICAL LIBRARY
REFERENCE COPY

1521

3387

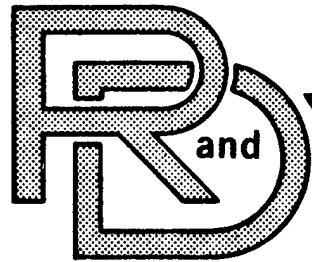

TACOM

Project Manager, M60 Tanks

TECHNICAL REPORT

NO. 12776

WINTER TESTING OF VEHICLE
EXHAUST DUST EJECTION SYSTEM, RUBBER
TIRE HUBS, AND PERSONNEL HEATER SYSTEM
ON THE M60 A3 TANK

JUNE 1982



Final Report

CONTRACT NO. DAAE07-81-G-4006
Delivery Order 0009

by Keweenaw Research Center
Division of Research
Michigan Technological University

Approved for Public Release:
Distribution Unlimited

U.S. ARMY TANK-AUTOMOTIVE COMMAND
Warren, Michigan 48090

Reproduced From
Best Available Copy

20011025 143

AN 46091

REPORT DOCUMENTATION PAGE		READ INSTRUCTIONS BEFORE COMPLETING FORM	
1. REPORT NUMBER 12776	2. GOVT ACCESSION NO.	3. RECIPIENT'S CATALOG NUMBER	
4. TITLE (and Subtitle) Winter Testing of Vehicle Exhaust Dust Ejection System, Rubber Tire Hubs, and Personnel Heater System on the M60 A3 Tank		5. TYPE OF REPORT & PERIOD COVERED Final Report	
		6. PERFORMING ORG. REPORT NUMBER	
7. AUTHOR(s) Keweenaw Research Center Div of Res Michigan Technological University, Houghton, MI 49931		8. CONTRACT OR GRANT NUMBER(s) DAAE07-81-G-4006 Delivery Order 0009	
9. PERFORMING ORGANIZATION NAME AND ADDRESS Keweenaw Research Center Div of Res Michigan Technological University, Houghton, MI 49931		10. PROGRAM ELEMENT, PROJECT, TASK AREA & WORK UNIT NUMBERS	
11. CONTROLLING OFFICE NAME AND ADDRESS William L. Ashley III DRCPM-M60-E		12. REPORT DATE June 1982	
		13. NUMBER OF PAGES 31	
14. MONITORING AGENCY NAME & ADDRESS (if different from Controlling Office)		15. SECURITY CLASS. (of this report) unclassified	
		15a. DECLASSIFICATION/DOWNGRADING SCHEDULE	
16. DISTRIBUTION STATEMENT (of this Report) Approved for Public Release: Distribution Unlimited			
17. DISTRIBUTION STATEMENT (of the abstract entered in Block 20, if different from Report)			
18. SUPPLEMENTARY NOTES Prepared for Project Manager M60 Tanks			
19. KEY WORDS (Continue on reverse side if necessary and identify by block number)			
M60 Tank Air Cleaner	Hubs	Tank Hub	
Tank Air Cleaner	Rubber Tire Hubs	Dust Detector	
Air Cleaner	Heater	Clean Air	
Air Induction System (AIS)	Personnel Heater	Vehicle Exhaust	
	Tank Heater	Dust Ejector Sys (VEDES)	
20. ABSTRACT (Continue on reverse side if necessary and identify by block number) This is a final test report of an environmental test in heavy snow conditions to evaluate the proposed clean air, rubber tire hubs and Model M personnel heater improvements to the M60 Tank. The test was conducted at the Keweenaw Research Center, Houghton, MI			

SUMMARY

An M60 A3 Tank underwent environmental testing in heavy snow conditions to evaluate the following:

1. How well the Vehicle Exhaust Dust Ejection System (VEDES) functioned in heavy snow.
2. How well the Rubber Tire Hubs (RTH) functioned in heavy snow.
3. How well the improved Stewart-Warner Model M Personnel Heater System functioned in cold weather.

Test results indicate that the Vehicle Exhaust Dust Ejection System needs further development if it is to be used in a heavy snow environment. The system reduced filter life and allowed exhaust gases to recirculate through the air induction system.

Results also indicate that the Rubber Tire Hubs need further development if they are to be used in a heavy snow environment. The hubs were too thick or improperly installed causing the sprocket and track to misalign. Snow build-up between the RTH sprocket and track caused the track to climb over the top of the teeth.

The personnel heater functioned properly. The unit was operated by the driver and kept him comfortably warm. The heater vent was removed after it vibrated and fell off a number of times.

TABLE OF CONTENTS

SUMMARY

TABLE OF CONTENTS

	<u>Page</u>
List of Illustrations.....	i
List of Tables.....	ii
1.0 Introduction.....	1
2.0 Vehicle Exhaust Dust Ejection System (VEDES).....	1
2.1 VEDES Installed on Right Side, ACBM Installed on Left Side.....	2
2.2 VEDES Installed on Both Sides.....	8
3.0 Rubber Tire Hubs.....	8
4.0 Personnel Heater Evaluation.....	19
5.0 Conclusions.....	22
6.0 References.....	23

Appendix A

Appendix B

LIST OF ILLUSTRATIONS

<u>Figure No.</u>	<u>Page</u>
1	VEDES air filter element and compartment after 5 miles of driving in a heavy snow storm..... 2
2	VEDES filter element after 50 miles of operation in powder snow..... 5
3	VEDES snow accumulation in pre-cleaner section..... 5
4	Snow accumulation on VEDES filter element after 50 miles of operation in powder snow..... 6
5	ACBM filter element after 50 miles of operation in powder snow..... 7
6	ACBM filter compartment after 50 miles of operation in powder snow..... 7
7	Diagram of VEDES system..... 9
8	VEDES ΔP transducer diagram..... 10
9	VEDES pressure transducer diagram..... 11
10	VEDES scavenge pressure transducer diagram..... 12
11	VEDES restriction indicator diagram..... 13
12	Track and sprocket misalignment..... 18
13	RTH track climbing over sprocket teeth because of snow build-up between track and sprocket..... 20
14	RTH snow build-up between track and sprocket..... 20
15	RTH snow build-up between track and sprocket..... 21
16	Test vehicle in typical snow environment..... 21

LIST OF TABLES

<u>Table No.</u>		<u>Page</u>
1	VEDES Data Summary.....	14

1.0 Introduction

Performance tests were conducted on an M60A3 Tank to determine how well the Vehicle Exhaust Dust Ejection System (VEDES), Rubber Tire Hubs (RTH), and improved Stewart-Warner Model M Personnel Heater System functioned in heavy snow and cold weather.

The vehicle was run for 500 miles in a snowy, cross-country environment. This included forward and reverse running at various speeds and terrain conditions. Transmission stall checks were also performed at random intervals.

For approximately half of the test, the tank's air induction system was equipped with the VEDES on the right side and standard Air Cleaner Blower Motors (ACBM) on the left side. For the second half of the test the vehicle was equipped with VEDES on both sides of the air induction system.

The drive sprockets were replaced with modified RTH sprockets on both left and right sides by TACOM. TACOM also installed the product improved Stewart-Warner Model M Personnel Heater System prior to its arrival at the Keweenaw Research Center.

2.0 Vehicle Exhaust Dust Ejection System

As stated in the Introduction, half of the 500-mile endurance test was run with VEDES on the right side of the air induction system and standard Air Cleaner Blower Motors on the left side. The last half of the test was conducted with VEDES installed on both sides. The test requirement that 10% of the test be run at 15 MPH and 10% of the test be run at 20 MPH could not be met because these speeds could not be maintained on the test track (Barlow, 1982).

2.1 VEDES Installed on Right Side, ACBM Installed on Left Side

Both the VEDES and ACBM air filter elements would clog up with snow when the vehicle was operated in freshly fallen or powder (very light and dry) snow. The VEDES filter element did clog up fast, however. Figure 1 shows the VEDES filter compartment after 5 miles of driving in a heavy snow storm. The restriction indicator reached 30 inches of water.



Figure 1. VEDES filter element and filter compartment after 5 miles of driving in a heavy snow storm.

At the end of 250 miles, an inspection of the air induction system was made. The filter elements were clean and dry before each day's testing. The results of the inspection are listed below.

1. The VEDES had 1/4-inch deep accumulation of brown water in the air filter element compartment and pre-cleaner compartment.
2. The VEDES filter element was brown in color and had an exhaust gas odor.
3. Water was also found in the VEDES scavenge tube and check valve.
4. The ACBM air cleaner was wet, with slight accumulation of clear water in the corners of the filter box. No accumulation of water was found in the pre-cleaner.
5. The ACBM filter was not discolored and did not contain exhaust gas odor.

After the inspection the air filters were changed, and the filter compartments were cleaned and dried. After 50 miles of driving in powder snow another inspection was performed. The results of the inspection follow.

1. A heavy layer of snow had accumulated on the VEDES filter element. The snow covered approximately 75% of the filter media on both sides of the filter element. Figure 2 shows the filter element covered with snow.

2. Snow had accumulated in the pre-cleaner and had reached the top of the scavenge cleanout plug. See Figure 3.
3. Restriction on the VEDES filter element had reached 20 inches of water. See Figure 4.
4. The VEDES check valve was found to be frozen shut as a result of water accumulation and freezing in the scavenge tube.
5. A layer of snow covering approximately 25% of the ACBM filter element was found. See Figures 5 and 6.
6. Restriction on the ACBM filter element had reached 4.8 inches of water.
7. There was no accumulation of snow in the pre-cleaner compartment of the ACBM system.

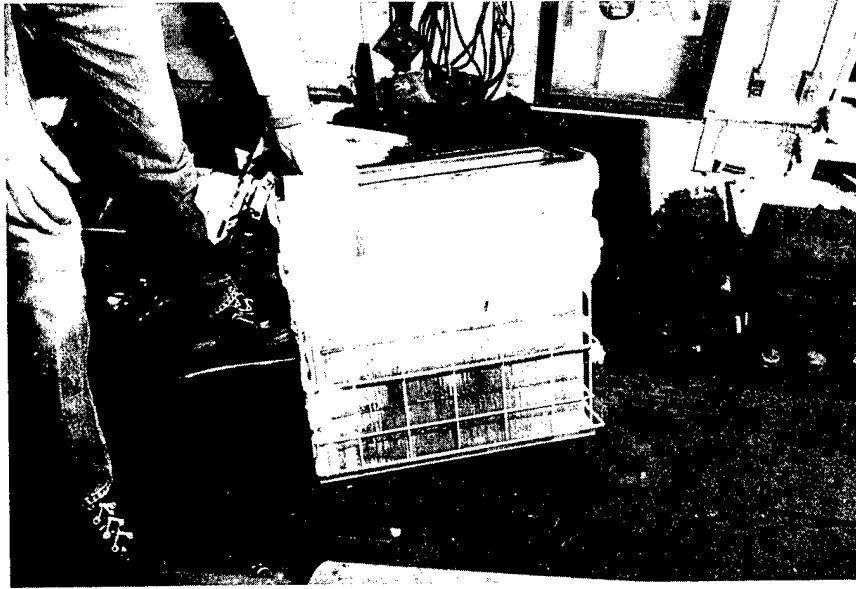

Figure 2. VEDES filter element after 50 miles of operation in powder snow.

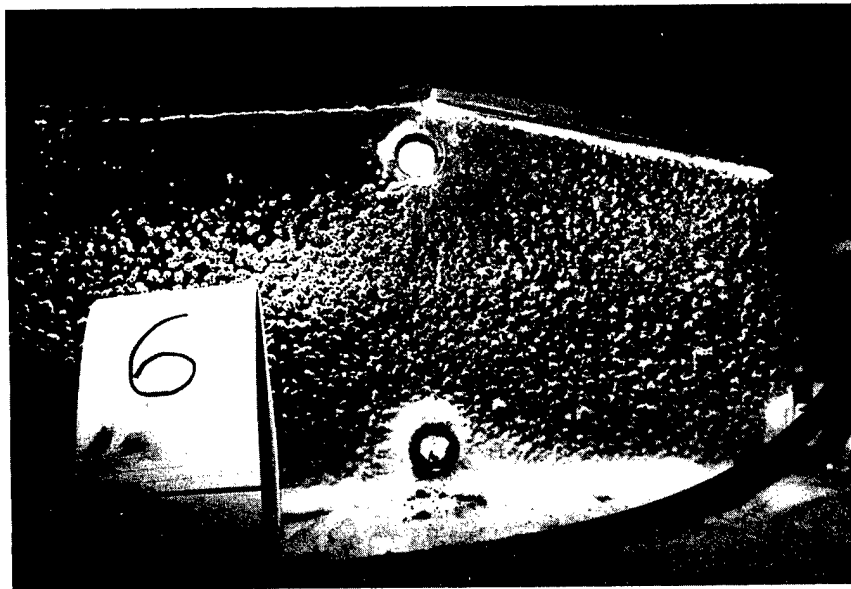

Figure 3. Snow accumulation in the pre-cleaner after 50 miles of operation in powder snow reached the top of the scavenge cleanout plug.



Figure 4. Snow accumulation on the VEDES filter element after 50 miles of operation in powder snow. The restriction indicator reached 20 inches of water.

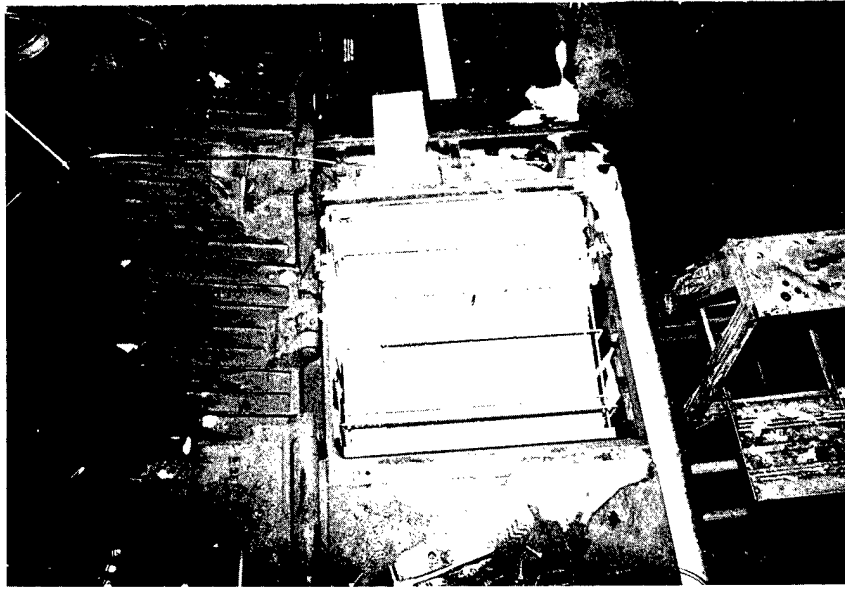

Figure 5. ACBM filter element after 50 miles of operation in powder snow.

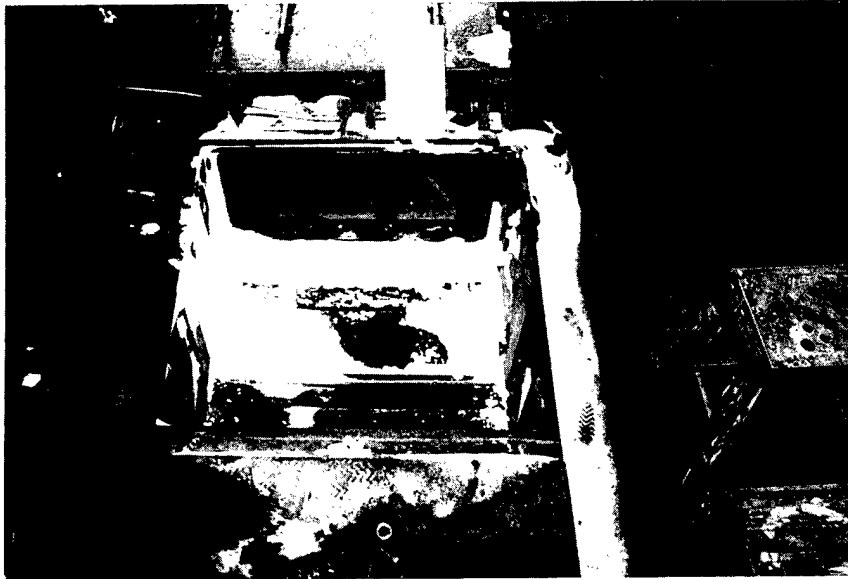

Figure 6. ACBM filter compartment after 50 miles of operation in powder snow.

2.2 VEDES Installed on Both Sides

After 300 test miles, the ACBM's were removed and replaced with VEDES. The test vehicle was then run an additional 200 miles with VEDES on both sides.

After completion of the testing, the VEDES filter elements were examined. The elements were discolored from what appeared to be exhaust gas recirculation up through the scavenge tube. This indicates that flow reversal can occur even when the VEDES is operating as designed. The filter elements were sent to General Dynamics Land Systems Division for further analysis.

Water accumulation in the scavenge tube occurs as a result of flow reversal. When the vehicle is parked outside in cold temperatures, the VEDES check valve freezes shut. The frozen valve must be broken free before the vehicle can be operated. Monitoring the differential pressure across the tube can alert the driver of blockages resulting from either a frozen check valve or accumulation of snow in the tube. (DiDonato, 1982).

Figures 7-11 show diagrams of the VEDES System, VEDES ΔP Transducer, VEDES Scavenge Pressure Transducer, and VEDES Restriction Indicator, respectively. Table 1 gives a summary of the VEDES data.

3.0 Rubber Tire Hubs (RTH)

The M60 A3 Tank was equipped with modified final drive sprockets, rubber tire hubs, by TACOM. The vehicle was driven 500 miles in snow to determine the ability of the RTH to properly function in a heavy snow environment.

When the test vehicle arrived at the Keweenaw Research Center

Vehicle Exhaust Dust Ejector System (VEDES)
for AVDS-1790/M60

(Left Side Only Shown)

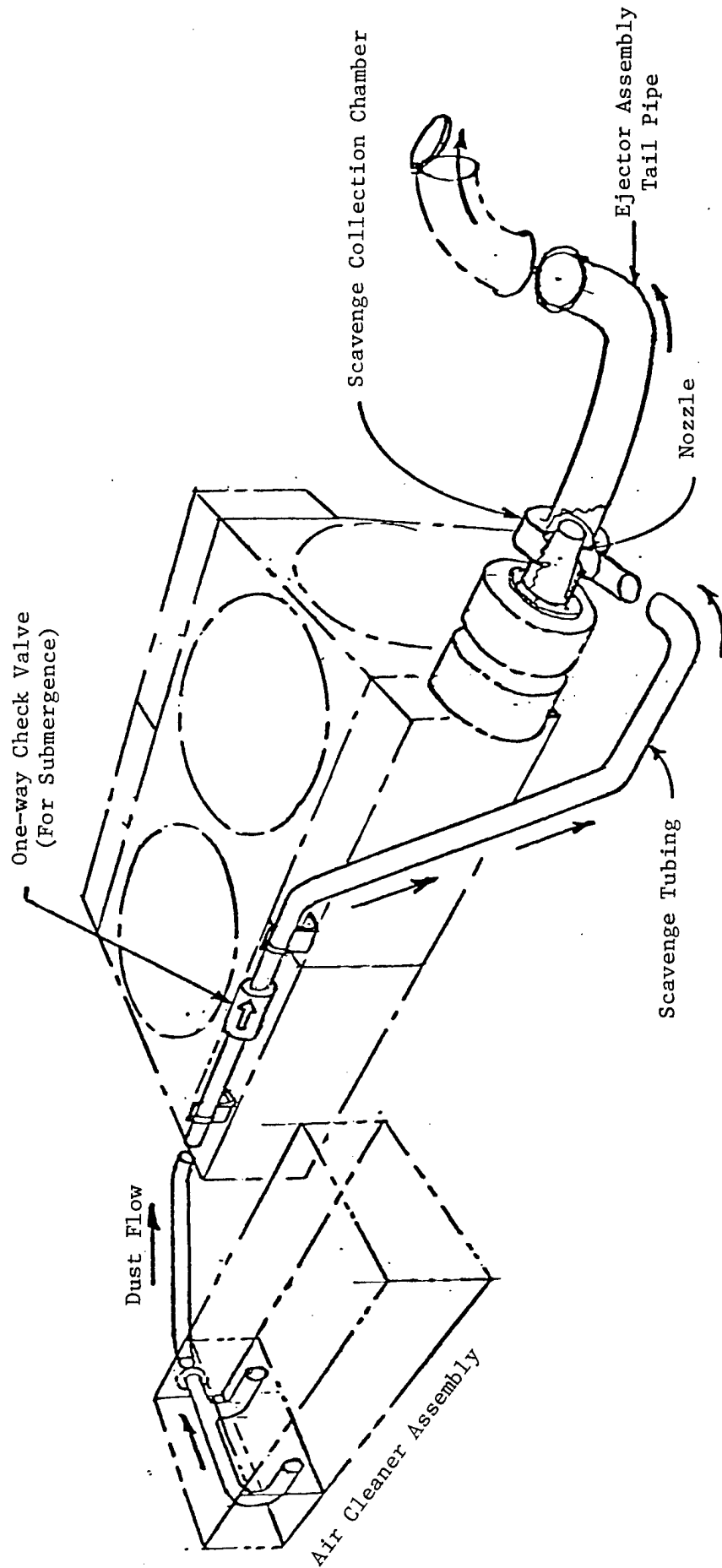

Figure 7. Diagram of VEDES System

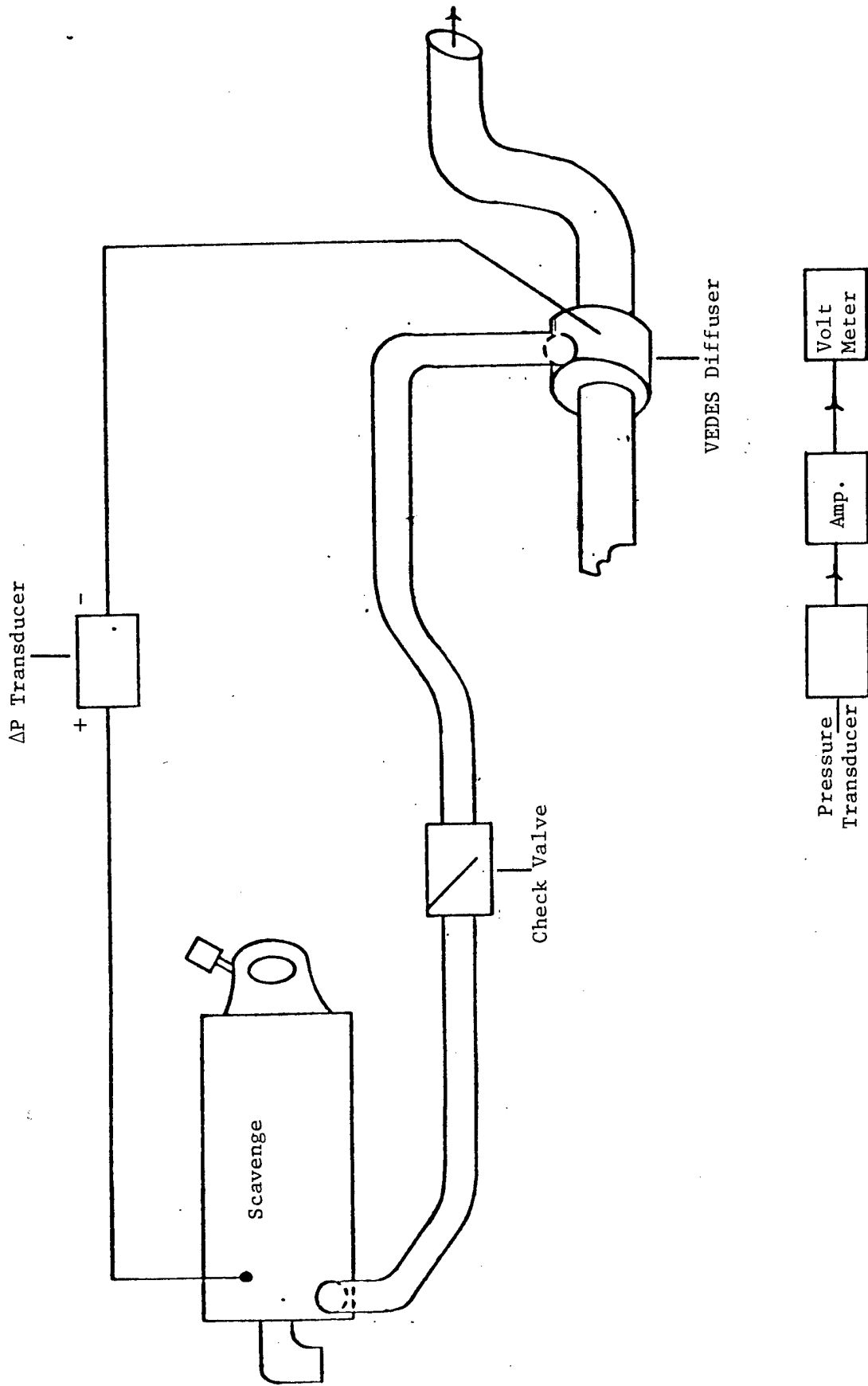

Figure 8. Transducer Diagram for ΔP

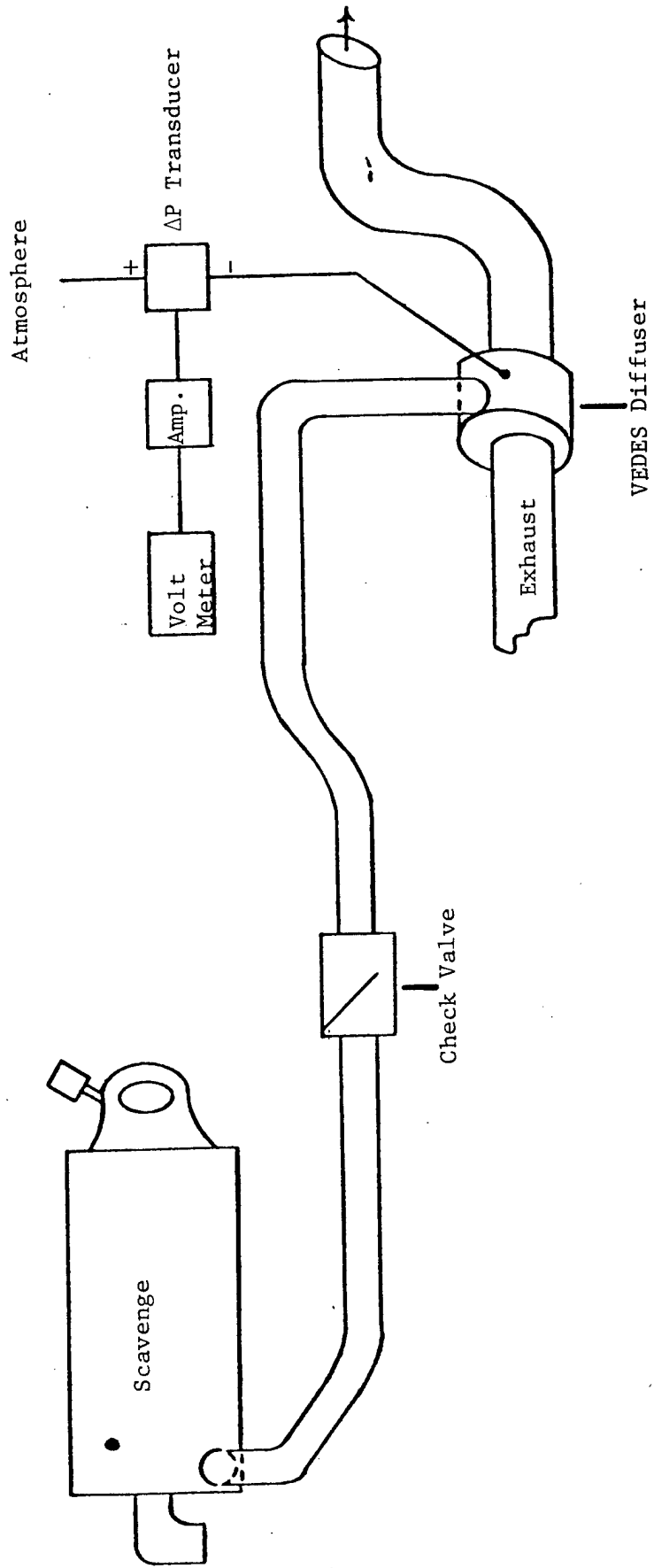

Figure 9. Pressure Transducer Diagram for VEDES

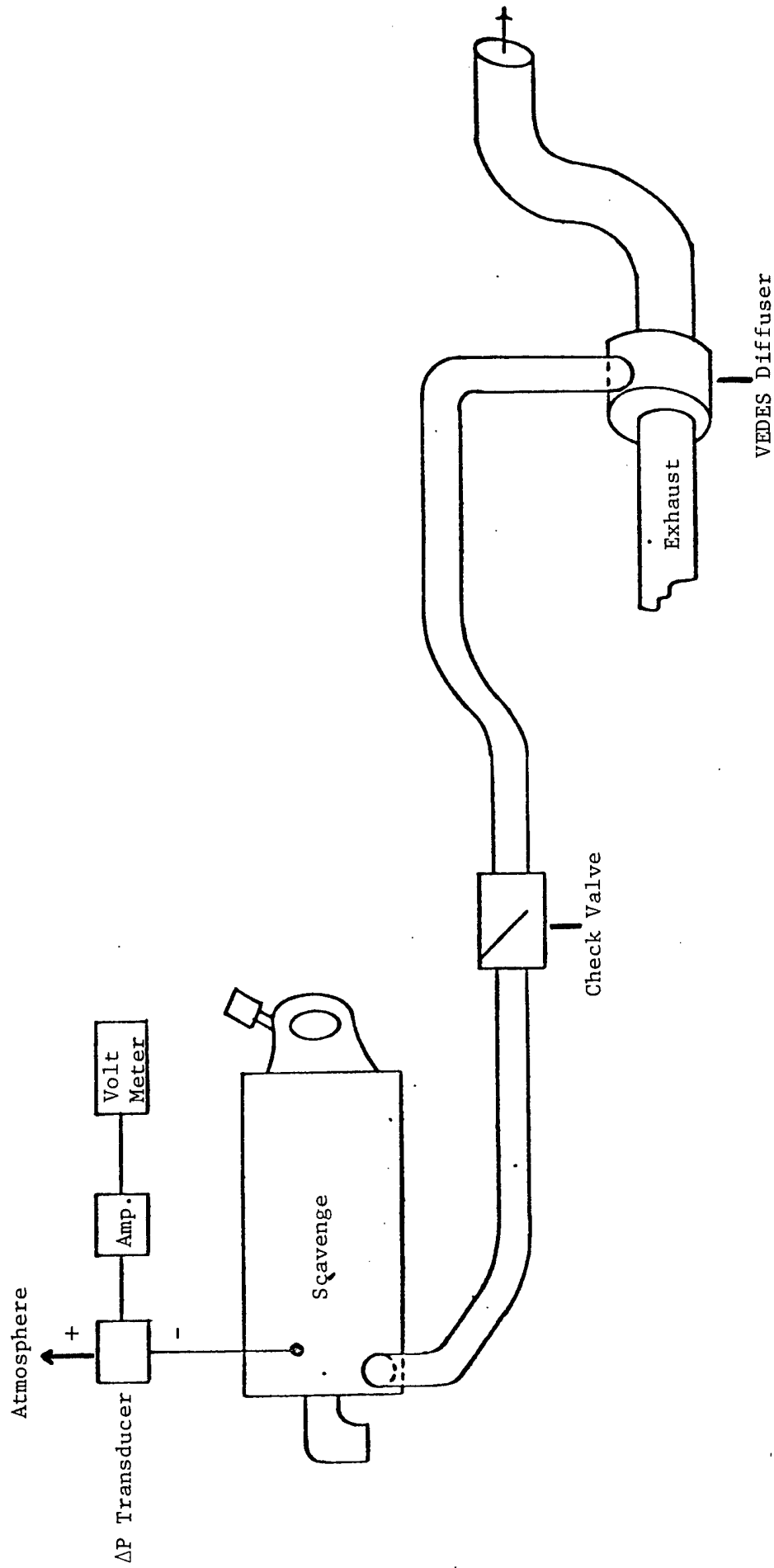

Figure 10. Transducer Diagram for Scavenge

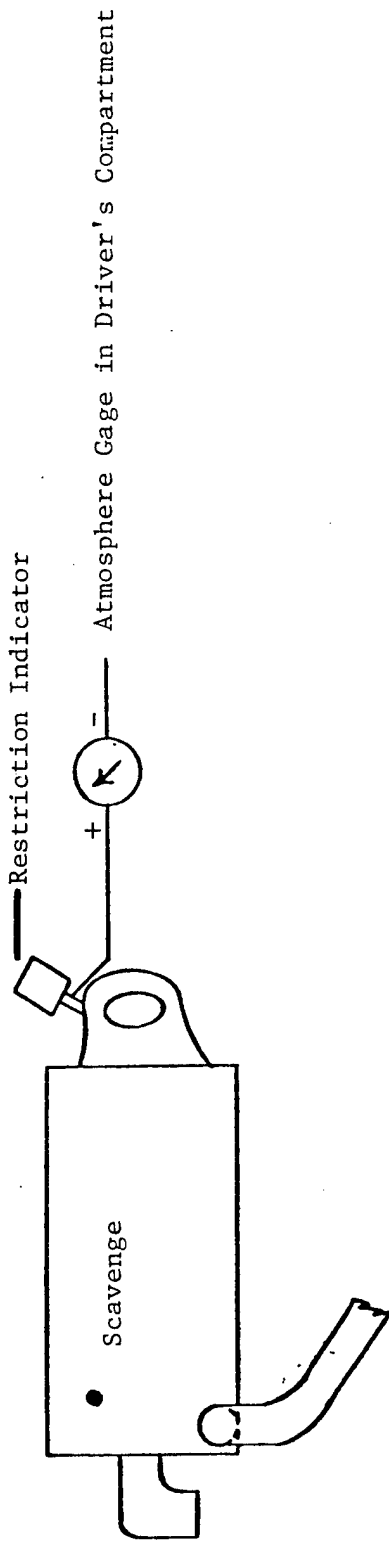

Figure 11. Transducer Diagram for Restriction Indicator

Table 1. VEDES Data Summary

PRESSURE DIFFERENTIALS
(Inches H₂O)

Date	Time of Day	ΔP System	Scavenge	Restriction Indicator		ACBM Operation	Snow Condition	Amount of Snow in Filter Box	
				VEDES	ACBM			VEDES	ACBM
02-02-82	1300			0.0	0.0	Yes	Dry	None	None
	1520			0.0	0.0	Yes	Dry	None	None
02-03-82	1625			0.0	0.0	Yes	Powder	33%	None
	0600			0.0	0.0	Yes	Powder	None	None
02-04-82	0730			0.0	0.0	Yes	Powder	None	None
	1530			0.0	0.0	Yes	Powder	None	None
02-09-82	1030			0.0	0.0	Yes	Powder	None	None
	1400			35.0	0.0	Yes	Powder	35%	5%
02-10-82	1530			0.0	0.0	Yes	Powder	100%	7%
	0930			0.0	0.0	Yes	Powder	Trace	Trace
02-18-82	1030			0.0	0.0	Yes	Crystal	None	None
	1130			0.0	0.0	Yes	Crystal	None	None
02-21-82	1330			0.0	0.0	Yes	Crystal	None	None
	1430			0.0	0.0	Yes	Crystal	None	None
02-21-82	1030			0.0	0.0	Yes	Crystal	None	None
	1130			0.0	0.0	Yes	Crystal	None	None
02-21-82	1330			0.0	0.0	Yes	Crystal	None	None
	1430			0.0	0.0	Yes	Crystal	None	None
02-21-82	1030			0.0	0.0	Yes	Crystal	None	None
	1530			0.0	0.0	Yes	Crystal	None	None

Table 1. VEDES Data Summary (Cont'd)

PRESSURE DIFFERENTIALS
(Inches H₂O)

Date	Time of Day	AP System	Scavenge	Restriction Indicator		Restriction Indicator Left ACBM	ACBM Operation	Snow Condition	Amount of snow in Filter Box	
				Right VEDES	VEDES				VEDES	ACBM
02-23-82	0930			0.0		0.0	Yes	Powder	Trace	Trace
	1030			0.0		0.0	Yes	Powder	5%	Trace
	1130			0.0		0.0	Yes	Powder	5%	Trace
	1330			0.0		0.0	Yes	Powder	5%	Trace
	1430			0.0		0.0	Yes	Powder	5%	Trace
02-24-82	0930			0.0		0.0	Yes	Powder	7%	Trace
	1030			0.0		0.0	Yes	Powder	7%	Trace
	1130			0.0		0.0	Yes	Powder	7%	Trace
	1330			0.0		0.0	Yes	Powder	7%	Trace
	1430			0.0		0.0	Yes	Powder	7%	Trace
02-25-82	0930			0.0		0.0	Yes	Powder	7%	Trace
	1030			0.0		0.0	Yes	Crystal	7%	Trace
	1130			0.0		0.0	Yes	Crystal	7%	Trace
	1330			0.0		0.0	Yes	Crystal	4%	Trace
	1430			0.0		0.0	Yes	Crystal	4%	Trace
	1530			0.0		0.0	Yes	Crystal	4%	Trace

Table 1. VEDES Data Summary (Cont'd)

PRESSURE DIFFERENTIALS
(Inches H₂O)

Date	Time of Day	ΔP System	Scavenge	VEDES	Restriction Indicator		ACBM Operation	Snow Condition	Amount of Snow in Filter Box		
					Right VEDES	Left ACBM			VEDES	ACBM	
02-26-82	0930				0.0	0.0	Yes	Crystal	5%	2%	
	1030				0.0	0.0	Yes	Crystal	5%	2%	
	1130				0.0	0.0	Yes	Crystal	5%	2%	
	1330				0.0	0.0	Yes	Crystal	5%	2%	
	1430				0.0	0.0	Yes	Crystal	5%	2%	
	1530				0.0	0.0	Yes	Crystal	5%	2%	
03-04-82	----				0.0	0.0	Yes	Crystal	None	None	
03-08-82	1200				0.0	0.0	Yes	Powder	None	None	
	1600				0.0	0.0	Yes	Powder	30%	18%	
03-09-82	1600				20.0	0.0	Yes	Powder	50%	25%	
-----VEDES Installed Both Sides-----											
Cold Soak	5 MPH 10 MPH 15 MPH Stall Check 1900 RPM	03-16-82	0930	Right		Left		Right		Left	
				4.0	3.5	3.0	3.0	4.0	4.0	2.0	3.5
				4.0	3.5	5.5	4.0	5.5	5.0	6.5	5.0
				5.5	6.5	8.0	8.0	10.0	11.0	8.5	7.5
			1130	6.5	5.5	8.0	8.0	11.0	10.0	7.5	8.5

Amb. Temp.
32°F
32°F
32°F
32°F

Table 1. VEDES Data Summary (Cont'd)

PRESSURE DIFFERENTIALS
(Inches H₂O)

Date	Time of Day	AP System	Scavenge				VEDES				Restriction Indicator Right VEDES	Restriction Indicator Left ACBM	ACBM Operation	Snow Condition	Amount of Snow in Filter Box VEDES ACBM
			Right	Left	Right	Left	Right	Left	Right	Left					
-----VEDES Installed Both Sides-----															
03-17-82	0830	5 MPH	4.0	4.0	3.0	3.5	4.5	4.0	4.0	4.0	2.5	4.0	31°F		
		10 MPH	6.0	4.5	4.0	4.5	7.5	6.0	6.5	5.5	31°F				
		15 MPH	6.0	6.5	6.0	6.0	11.5	7.5	5.0	7.0	31°F				
	1130	Stall Check	7.0	6.0	8.5	8.5	11.5	11.0	8.0	9.0	37°F				
		5 MPH	3.5	3.0	2.0	3.0	4.0	4.0	2.0	3.5	36°F				
		10 MPH	4.0	4.0	4.0	4.0	5.0	5.5	4.0	5.0					
03-18-82	0830	15 MPH	7.0	6.0	7.0	7.5	11.5	10.0	8.5	9.0	Stall Check 1900 RPM				
		5 MPH	7.0	6.0	8.0	8.0	11.0	10.0	7.0	8.5	32°F				
		10 MPH	3.5	3.5	3.5	4.0	4.0	4.5	3.0	4.0					
	1130	10 MPH	5.0	4.5	4.5	4.5	6.0	7.0	4.5	6.0	33°F				
		15 MPH	6.5	7.0	9.0	6.0	12.0	13.0	8.5	9.5	33°F				
		5 MPH	7.0	6.0	8.0	8.5	11.5	10.5	8.0	8.5	Stall Check 1900 RPM				
03-19-82	0830	10 MPH	3.5	3.5	3.5	3.5	4.5	4.5	2.0	4.0	Stall Check 1950 RPM				
		15 MPH	4.5	4.0	4.0	4.5	5.5	6.0	4.0	5.5	19°F				
		5 MPH	6.0	6.0	8.5	8.5	9.0	10.0	7.5	8.0					
	1130	10 MPH	7.0	6.0	8.5	8.5	11.5	10.5	8.0	9.0	20°F				
		15 MPH	4.0	3.5	3.0	4.0	4.5	4.5	3.0	5.0	Stall Check 1900 RPM				
		5 MPH	4.5	4.0	4.0	4.0	5.0	5.5	4.5	5.5					

it was noted that there was a mismatch between the RTH sprockets and the track end connectors. This mismatch caused wear to the sprocket teeth and end connectors as seen in Appendix A. Appendix A shows wear to three selected end connectors on both sides of the track as well as the wear to the RTH sprockets.

One set of tracks was worn out after 250 miles of operation. The track was replaced with a spare, and end connector and sprocket wear were recorded. Figure 12 shows the excessive wear between the sprocket teeth and end connectors after 250 miles.

Snow was definitely a problem for the rubber tire hubs. The hubs would pack with snow and cause the track to jump over the drive sprocket teeth. The driver had to be careful not to jump the track.

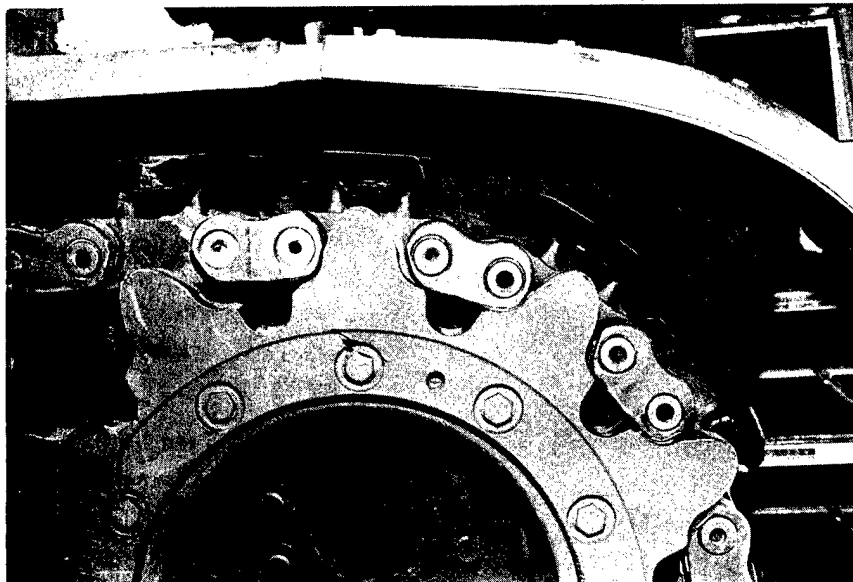

Figure 12. Track and sprocket misalignment and excessive end connector wear (250 miles).

Figure 13 shows the track climbing over the top of the sprocket teeth. Figures 14 and 15 show the snow build-up between the RTH and the track causing the track to lift up and misalign. Figure 16 shows the test vehicle operating in a typical snow environment.

4.0 Personnel Heater Evaluation

A Stewart-Warner Model M Personnel Heater consisting of a heated fuel/water separator filter assembly, 5-inch hot air ducting, and an improved hot air vent was evaluated on the M60 A3 test vehicle. The only crew member was the driver, and he operated the heater to his comfort.

The heater functioned properly throughout the test and kept the driver comfortably warm. There was a problem with the hot air vent vibrating and falling off, so it was removed. General Dynamics Land Systems Division measured the temperature inside the tank during the course of the test, and the results are in Appendix B.

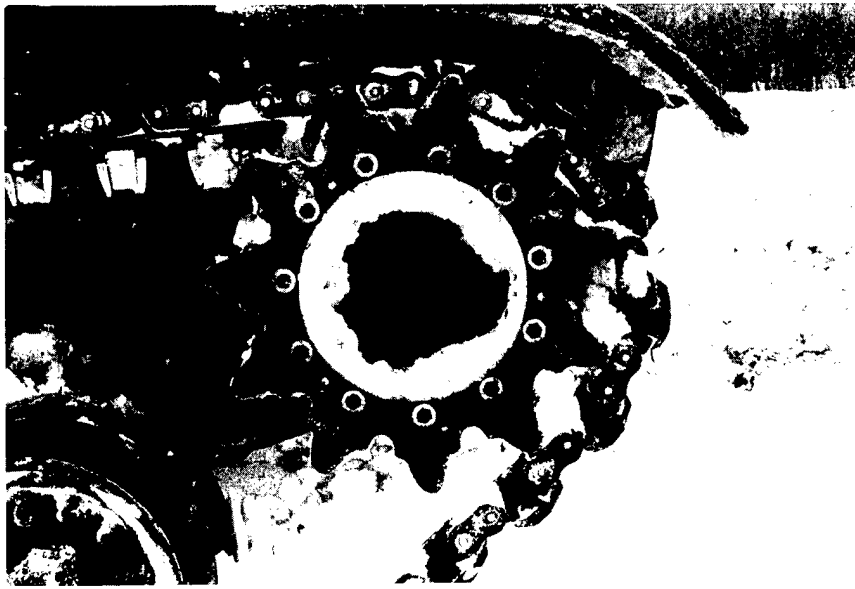

Figure 13. Snow build-up between the track and sprocket caused the track to climb over the sprocket teeth.



Figure 14. Snow build-up between the track and sprocket

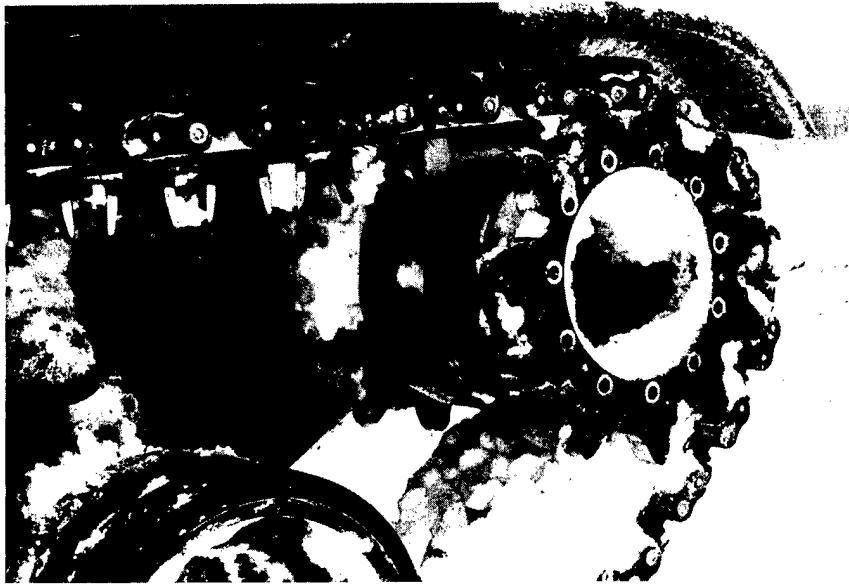

Figure 15. Snow build-up between the track and sprocket.



Figure 16. Test vehicle operating in a typical snow environment.

5.0 Conclusions

VEDES

1. VEDES reduced filter life in a winter environment.
2. VEDES allowed gases to recirculate through the air induction system (flow reversal).
3. VEDES needs further development and testing.

RTH

1. The Rubber Tire Hubs were improperly installed or were too thick, causing the sprocket and track to misalign.
2. Snow can buildup between the RTH sprocket and track, causing the track to climb over the top of the teeth.
3. RTH needs further development and testing.

Personnel Heater

1. The personnel heater functioned properly throughout the test and kept the driver comfortably warm.
2. The hot air vent did vibrate and fall off a number of times and needs to be better secured in future use.

6.0 References

Weekly progress and performance reports by Gerald E. Barlow, Site Test Engineer, General Dynamics Land Systems Division, 27 Feb. 1982.

Trip Report by Angelo DiDonato, Test Engineering Dept. 8323, General Dynamics Land Systems Division, 11 March 1982.

APPENDIX A

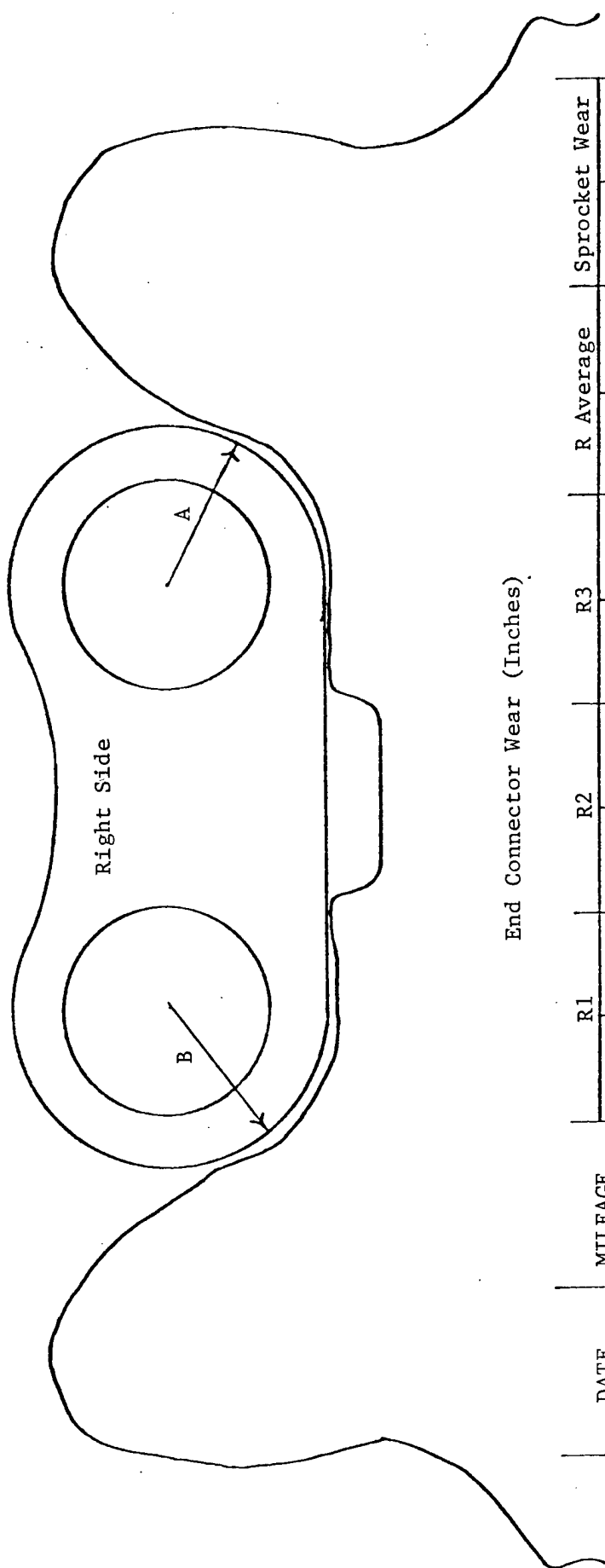

End Connector Wear (Inches)

DATE	MILEAGE	R1		R2		R3		R Average		Sprocket Wear	
		A	B	A	B	A	B	A	B	A	B
03/09/82	2138.6	.429	.425	.480	.400	.452	.445	.454	.423	.384	.329
03/12/82	2186.2	.426	.398	.460	.352	.479	.409	.455	.386	.387	.308
03/17/82	2248.9	.422	.396	.453	.370	.425	.375	.433	.380	.374	.325
03/18/82	2301.0	.455	.410	.462	.353	.424	.374	.447	.379	.380	.317
03/22/82	2361.9	.423	.397	.454	.341	.476	.418	.451	.385	.373	.328

M60 Track End Connector and Sprocket Wear Data
Snow Testing of Rubber Tire Hubs

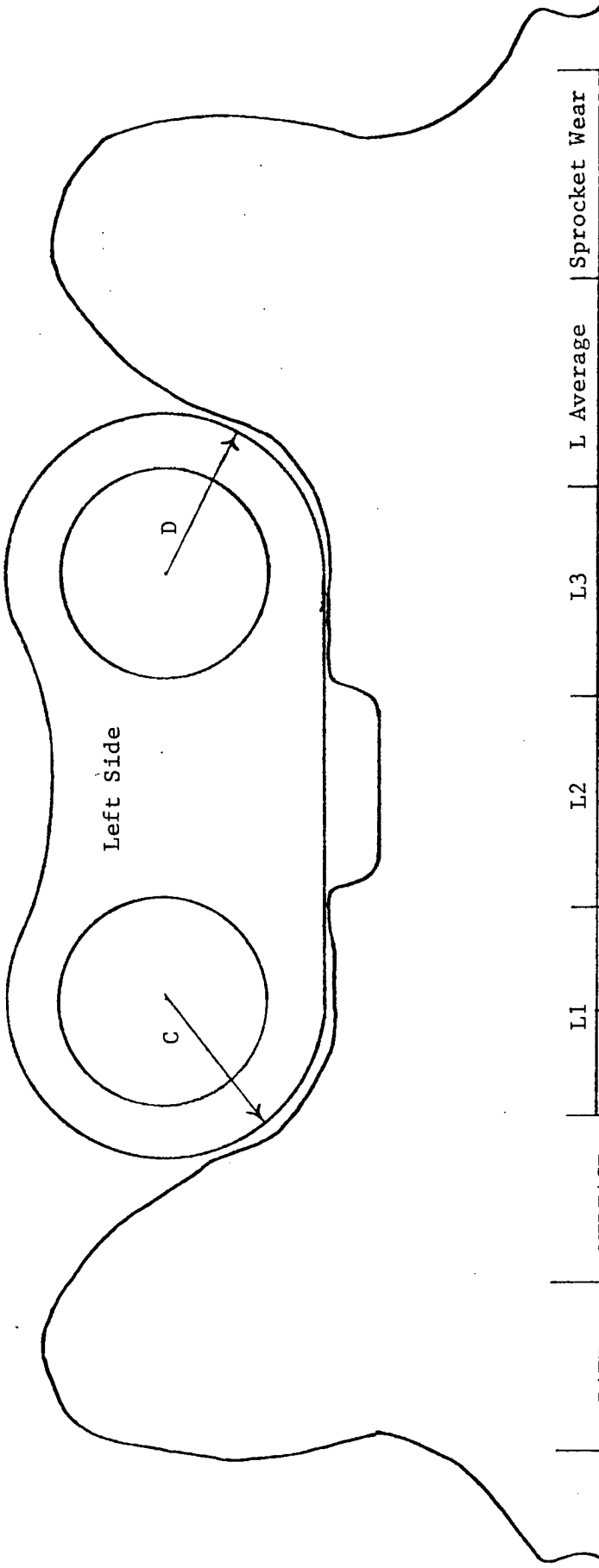

DATE	MILEAGE	L1		L2		L3		L Average		Sprocket Wear	
		C	D	C	D	C	D	C	D	C	D
03/09/82	2138.6	.440	.438	.462	.401	.462	.473	.471	.437	.460	.328
03/12/82	2186.2	.472	.412	.450	.371	.418	.459	.447	.414	.350	.335
03/17/82	2248.9	.468	.406	.453	.340	.421	.453	.447	.400	.352	.317
03/18/82	2301.0	.454	.398	.433	.367	.411	.433	.433	.399	.358	.326
03/22/82	2361.9	.456	.403	.436	.439	.402	.439	.431	.427	.359	.329

M60 Track End Connector and Sprocket Wear Data
Snow Testing of Rubber Tire Hubs

APPENDIX B

KEWEENAW TEST CENTER
HOUGHTON MEMORIAL AIRPORT
HOUGHTON, MICHIGAN

TURRET "COOL DOWN" WITH ENGINE AIR INTAKE FROM TURRET
CONDUCTED MONDAY, 15 MARCH 1982

M60A3, S/N 005, EQUIPPED WITH DUAL AIR MODEL M HEATER
VEHICLE PARKED WITHIN BUILDING OVER WEEKEND IN ANTICIPATION OF
MAINTENANCE ACTION, BUILDING AMBIENT 65°. UPON COMPLETION OF
MAINTENANCE VEHICLE DRIVEN OUTSIDE AND FOUR COMMON MERCURY BULB
LABORATORY 11" THERMOMETERS PLACED AS FOLLOWS: 1, DRIVERS SEAT,
2, LOADERS SEAT, 3, COMMANDERS SEAT, AND 4, GUNNERS SEAT.
ALL HATCHES CLOSED AFTER HEATER OPERATION PLACED ON HIGH.

THERMOMETER READINGS TAKEN AFTER ONE HOUR, THEN FIFTEEN MINUTES
LATER. HATCHES THEN PLACED IN FULL OPEN POSITION AND ENGINE
STARTED AND LEFT AT IDLE (800 RPM) FOR ONE HALF HOUR AND TEMPERATURE
READINGS TAKEN ONCE MORE.

	OUTSIDE				
	AMBIENT	LOADERS	COMMANDER	GUNNER	DRIVER
2:00 PM	37°		*	*	*
3:00	37	89°	(29) 84.2	(35) 95	(32) 89.6
3:15	37	92	(32) 89.6	(38) 100.4	(34) 93.2
3:45	37	88	(25) 77	(33) 91.4	(24) 75.2

*CENTIGRADE READING CONVERTED TO FARINHEIGHT

TIME CONSTRAINTS LIMITED DATA. VEHICLE MAINTENANCE ENDED JUST PRIOR
TO 2:00 PM AND SHIFT ENDED AT 4:00 PM

KEWEENAW TEST CENTER
HOUGHTON MEMORIAL AIRPORT
HOUGHTON, MICHIGAN

TURRET "COOL DOWN" WITH ENGINE AIR INTAKE DRAWN FROM TURRET
CONDUCTED TUESDAY, 16 MARCH 1982

M60A3, S/N 005, EQUIPPED WITH DUAL AIR MODEL M HEATER

TURRET ORIENTED TO REAR, BARREL IN TRAVEL LOCK.

FOUR COMMON LABRATORY MERCURY BULB 11" THERMOMETERS PLACED

1. TO LEFT OF DRIVERS SHOULDER
2. COMMANDERS SEAT BACK REST
3. GUNNERS SEAT CUSHION
4. ATOP FOLDED LOADERS SEAT

COLUMN A - OPERATED ON COURSE THREE HOURS, DRIVERS HATCH OPEN,
TURRET HATCHES CLOSED, HEATER ON "HI"
OUTSIDE AMBIENT 32°, READINGS TAKEN AT 11:30 A.M.

COLUMN B - OPERATED ON COURSE THREE AND ONE-HALF HOURS, DRIVERS
HATCH OPEN, TURRET HATCHES CLOSED, HEATER OFF DURING
ENTIRE PERIOD PLUS ONE HOUR BEGINNING COOL DOWN PERIOD
WITH HEATER OFF AND LOADERS PLUS DRIVERS HATCH OPEN.
OUTSIDE AMBIENT 31°, READINGS TAKEN AT 3:50 P.M.

COLUMN C - CLOSED UP AND PARKED OUTDOORS OVERNIGHT, OVERNIGHT
LOW 29° AT 9:00 P.M., 30° AT MIDNIGHT, WITH 32° AT
8:00 AM WHEN READINGS TAKEN 17 MARCH.

	COL A	COL B	COL C
DRIVERS LEFT SHOULDER	(15)* 59°	(6)* 42.8°	(5)* 41°
COMMANDERS SEAT	64	38	43
GUNNERS SEAT	(20) 68	(5) 41	(3.5) 38
LOADERS SEAT	(17) 62.6	(12) 53.6	(5) 41

*CENTIGRADE

KEWEENAW TEST CENTER
HOUGHTON MEMORIAL AIRPORT
HOUGHTON, MICHIGAN

18 MARCH 1982

TO: R. PAVER, FIELD TEST, DEPT. 8321, TEL. X0236/0233

TURRET TEMPERATURE REPORT
TURRET "COOL DOWN" WITH ENGINE AIR BEING DRAWN FROM TURRET
CONDUCTED WEDNESDAY 17 MARCH 1982

	COL A	COL B	COL C
DRIVERS LEFT SHOULDER	(5)* 41°	(3)* 37.4°	(24)* 75.2°
COMMANDER'S SEAT	43	41	71
GUNNERS SEAT	(3.5) 38	(2.5) 36.5	(21) 69.8

*CENTIGRADE

COL A - OVERNIGHT COLD SOAK OF VEHICLE, CLOSED UP, AMBIENT LOW 29° AT 9:00 PM, 30° AT MIDNIGHT, AND 32° AT 8:00 AM WHEN READINGS TAKEN. ODOM 2249.

COL B - VEHICLE OPERATED ON COURSE DURING MORNING, HEATER "OFF", DRIVERS HATCH OPEN, TURRET HATCHES CLOSED. AMBIENT TEMPERATURE FROM 32° TO 37°, ODOM 2268. READINGS AT 11:30 AM.

COL C - OPERATED ON COURSE DURING AFTERNOON, HEATER ON "HI", DRIVERS HATCH OPEN, TURRET HATCHES CLOSED. AMBIENT TEMPERATURE WENT FROM 37° TO 36°, ODOM 2293, READINGS AT 3:30 PM.

TURRET ORIENTED TO REAR, BARREL IN TRAVEL LOCK.

11" LABORATORY MERCURY BULB THERMOMETERS PLACED AS INDICATED.

KEWEENAW TEST CENTER
HOUGHTON MEMORIAL AIRPORT
HOUGHTON, MICHIGAN

23 MARCH 1982

TO: R. PAVER, FIELD TESTS, DEPT 8321, TEL X0236/0233

TURRET TEMPERATURE REPORT, DATA COLLECTED FOR THURSDAY 18 MARCH
AND FRIDAY 19 MARCH 1982.

	COL A		COL B		COL C
DRIVERS LEFT SHOULDER	(12.5)	56.3	(12)	53.6	(3.5) 38.3
COMMANDERS SEAT		68		70	54
GUNNERS SEAT	(16.5)	61.7	(15)	59	(10.5) 50.9

COL A - READINGS TAKEN AT 11:30 AM, VEHICLE OPERATED ON COURSE,
HEATER ON "HI", DRIVERS HATCH OPEN, TURRET HATCHES CLOSED, AMBIENT
TEMP FROM 32° to 33°, ODOM 2312.

COL B - READINGS TAKEN AT 3:30 PM, VEHICLE OPERATED ON COURSE,
HEATER ON "HI", DRIVERS HATCH OPEN, TURRET HATCHES CLOSED, AMBIENT
TEMP RANGE FROM 33° TO 31°, ODOM 2337.

COL C - READINGS TAKEN AT 11:30 AM, VEHICLE OPERATED ON COURSE,
HEATER ON "HI", DRIVERS HATCH OPEN, TURRET HATCHES CLOSED, AMBIENT
TEMP FROM 19° TO 20° WITH OVERNIGHT LOW OF 17°, ODOM 2361 MILES.

TURRET ORIENTED TO REAR, BARREL IN TRAVEL LOCK.

11" LABRATORY MERCURY BULB THERMOMETERS PLACED AS INDICATED

GERALD E. BARLOW
SITE TEST ENGINEER