

DOT/FAA/AR-01/44

Office of Aviation Research
Washington, D.C. 20591

Statistical Loads Data for Cessna 172 Aircraft Using the Aircraft Cumulative Fatigue System (ACFS)

August 2001

Final Report

DISTRIBUTION STATEMENT A
Approved for Public Release
Distribution Unlimited

This document is available to the U.S. public
through the National Technical Information
Service (NTIS), Springfield, Virginia 22161.



U.S. Department of Transportation
Federal Aviation Administration

20011120 079

NOTICE

This document is disseminated under the sponsorship of the U.S. Department of Transportation in the interest of information exchange. The United States Government assumes no liability for the contents or use thereof. The United States Government does not endorse products or manufacturers. Trade or manufacturer's names appear herein solely because they are considered essential to the objective of this report. This document does not constitute FAA certification policy. Consult your local FAA aircraft certification office as to its use.

This report is available at the Federal Aviation Administration William J. Hughes Technical Center's Full-Text Technical Reports page: actlibrary.tc.faa.gov in Adobe Acrobat portable document format (PDF).

1. Report No. DOT/FAA/AR-01/044		2. Government Accession No.		3. Recipient's Catalog No.	
4. Title and Subtitle STATISTICAL LOADS DATA FOR CESSNA 172 AIRCRAFT USING THE AIRCRAFT CUMULATIVE FATIGUE SYSTEM (ACFS)				5. Report Date August 2001	
				6. Performing Organization Code	
7. Author(s) Dr. John A. Cicero, Frank L. Feiter, and Dr. Jamshid Mohammadi				8. Performing Organization Report No.	
9. Performing Organization Name and Address Systems & Electronics, Inc. 190 Gordon Street Elk Grove Village, IL 60007				10. Work Unit No. (TRAIS) RPD-510	
				11. Contract or Grant No. DTRS-57-93-C-00172	
12. Sponsoring Agency Name and Address U.S. Department of Transportation Federal Aviation Administration Office of Aviation Research Washington, DC 20591				13. Type of Report and Period Covered Final Report	
				14. Sponsoring Agency Code ACE-110	
15. Supplementary Notes This research was conducted under SBIR Phase II research program. The FAA William J. Hughes Technical Center Technical Monitor was Mr. Thomas DeFiore.					
16. Abstract The purpose of this research and development program was to manufacture a small, lightweight, low-cost recorder for loads usage monitoring of general aviation and commuter type aircraft to support the Federal Aviation Administration (FAA) Operational Loads Monitoring Program. The scope of activities performed involved the following: (1) design, development, manufacturing and test of a low-cost Airframe Cumulative Fatigue System (ACFS), (2) installation of the ACFS into a fleet of seven Cessna 172 aircraft owned and operated by Embry-Riddle Aeronautical University, (3) conduct aircraft usage data acquisition on seven Cessna 172 aircraft, (4) define the effectiveness of ACFS in the data acquisition effort and any required design changes required for the ACFS, and (5) provide the resultant processed data from the data acquisition effort in formats useful to the FAA. Presented in this report are the description of the ACFS, the analysis and statistical summaries of the data collected from 1000 flights representing 1168 hours of Cessna 172 aircraft operational data. The end product from the data acquisition effort includes statistical information on acceleration, speeds, altitudes, and flight duration and distance.					
17. Key Words Loads, Normal acceleration, Airspeed, Altitude, Pitch, roll, and yaw rates, Cessna 172 airplane			18. Distribution Statement This document is available to the public through the National Technical Information Service (NTIS) Springfield, Virginia 22161.		
19. Security Classif. (of this report) Unclassified		20. Security Classif. (of this page) Unclassified		21. No. of Pages 96	22. Price

PREFACE

Systems & Electronics, Inc. (SEI) prepared this report under contract from the Federal Aviation Administration (FAA). SEI designed and developed an airframe cumulative fatigue system (ACFS) for general aviation and commuter aircraft. Nine of these systems were delivered to Embry-Riddle Aeronautical University (ERAU) to be installed on their fleet of Cessna 172 aircraft. To prove the effectiveness of this low-cost ACFS system, the ACFS equipped aircraft were flown for over 1000 hours. The results of the compiled flight loads and usage data are presented in this report.

Mr. Thomas J. Sepka, principal investigator, designed the ACFS system hardware. Dr. John A. Cicero developed the ACFS software. Dr. Cicero, Dr. Jamshid Mohammadi, Mr. Douglas Shoemaker, and Mr. Frank L. Feiter conducted the data analysis, data evaluation, and processing.

SEI would like to extend its appreciation to Mr. Thomas DeFiore of the FAA for the support to this program and to Dr. David Kim of ERAU who provided help in the acquisition of the recorded flight data.

TABLE OF CONTENTS

	Page
EXECUTIVE SUMMARY	ix
1. INTRODUCTION	1
2. AIRCRAFT DESCRIPTION	1
3. AIRCRAFT DATA COLLECTION AND EDITING SYSTEM	4
3.1 DATA COLLECTION SYSTEM	4
3.2 DATA EDITING SYSTEM	4
4. SEI DATA PROCESSING	4
4.1 RECORDED PARAMETERS	4
4.2 DERIVED AND EXTRACTED PARAMETERS	5
4.2.1 Identification of Liftoff and Touchdown	5
4.2.2 Flight Distance	5
4.2.3 Flight Duration	6
4.2.4 Design Load Factor Definition	6
4.2.5 Derived Gust Velocity	8
4.3 DATA REDUCTION	10
4.3.1 Initial Quality Screening	10
4.3.2 Time History Files	10
4.3.3 Relational Database	11
4.4 DATA REDUCTION CRITERIA	11
4.4.1 Ground/Flight Phases of Recorded Data	11
4.4.2 Sign Convention	11
4.4.3 Peak-Valley Selection	12
4.4.4 Separation of Maneuver and Gust Load Factors	12
4.4.5 Altitude Bands	12
4.4.6 Vertical Acceleration Bias Correction	14
5. DATA PRESENTATION	14
5.1 AIRCRAFT USAGE DATA	14
5.1.1 Altitude and Flight Distance Data	16
5.1.2 Coincident Airspeed and Altitude Data	17

5.1.3	Maximum Operating Airspeed Data	17
5.1.4	Flight Duration	17
5.2	GROUND LOADS DATA	17
5.2.1	Airspeed at Liftoff and Touchdown	18
5.2.2	Pitch Rate at Liftoff	18
5.2.3	Load Factor Data During Ground Operations	18
5.3	FLIGHT LOADS DATA	18
5.3.1	Gust Loads Data	18
5.3.2	Maneuver Loads Data	19
5.3.3	Combined Maneuver and Gust Loads Data	19
6.	CONCLUSIONS AND RECOMMENDATIONS	20
7.	REFERENCES	21

APPENDICES

- A—Statistical Formats, Aircraft Usage Data, All Aircraft
- B—Statistical Formats, Aircraft Usage Data, Daytona Aircraft
- C—Statistical Formats, Aircraft Usage Data, Prescott Aircraft

LIST OF FIGURES

Figure		Page
1	Cessna 172 Three-View Drawing	3
2	Description of Flight Phases	11

LIST OF TABLES

Table		Page
1	Cessna 172—Characteristics	2
2	Aircraft Dimensions	3
3	Altitude Bands	13
4	Flight Distance Ranges	13
5	Statistical Formats	15
6	Flight Characteristics of Surveyed Aircraft	20
7	Operational Load Monitoring Cessna 172	21

LIST OF SYMBOLS AND ABBREVIATIONS

\bar{A}	aircraft PSD gust response factor
A_N	incremental load factor at operating weight (n_z-1)
A_{NLLF}	incremental gust or maneuver design load factor at maximum gross weight (n_z-1)
A_r	aspect ratio b^2/S
a	speed of sound (ft/sec)
a_0	speed of sound at sea level (ft/sec)
ACFS	Airframe Cumulative Fatigue System
ADX	Air Data Transducer
b	wing span (ft)
\bar{c}	wing mean geometric chord (ft)
\bar{C}	aircraft discrete gust response factor
C_{l_α}	wing lift curve slope per radian
$C_{l_{max}}$	maximum lift coefficient
c.g.	center of gravity
D	distance
ERAU	Embry-Riddle Aeronautical University
$F(PSD)$	continuous gust alleviation factor
FAA	Federal Aviation Administration
fpm	feet per minute
ft	feet
g	gravity constant, 32.17 ft/sec ²
GPS	Global Positioning System
H_p	pressure altitude (ft)
hrs	hours
K	gust alleviation factor
K_g	discrete gust alleviation factor, $0.88 \mu / (5.3 + \mu)$
KCAS	knots, calibrated airspeed
KIAS	knots, indicated airspeed
kts	knots
L	turbulence scale length (ft)
lbs	pounds
m	lift curve slope per radian
M	Mach number
n	load factor (g)
N	number of occurrences for U_σ (PSD gust procedure)
nm	nautical mile
n_z	normal load factor (g)
N_0	number of zero crossings per nautical mile (PSD gust procedure)
q	dynamic pressure (lbs/ft ²)
ρ	air density, slugs/ft ³ (at altitude)
ρ_0	standard sea level air density 0.0023769 slugs/ft ³
S	wing area (ft ²)
SEI	Systems & Electronics, Inc.

μ	airplane mass ratio, $\frac{2(W/S)}{\rho g \bar{c} C_{l\alpha}}$
U_{de}	derived gust velocity (ft/sec, equivalent airspeed)
U_{σ}	continuous turbulence gust intensity (ft/sec, true airspeed)
V_B	design speed for maximum gust
V_C	design cruise speed
V_{CAS}	calibrated airspeed
V_D	design dive speed
V_e	equivalent airspeed
V_I	indicated airspeed
V_{NE}	maximum allowable operating airspeed
V_T	true airspeed
W	gross weight (lbs)

EXECUTIVE SUMMARY

Systems & Electronics, Inc. (SEI) under Contract DTRS-57-93-C-00172 to the Federal Aviation Administration (FAA), which was Phase II of a Small Business Innovation Development Phase I initiative, conducted research and development as presented herein. The purpose of this research and development program was to manufacture a small, lightweight, low-cost recorder for loads monitoring of general aviation and commuter type aircraft to support the FAA Operational Loads Monitoring Program. The scope of activities performed involved the following:

1. Design, development, manufacturing, and test of a low-cost Airframe Cumulative Fatigue System (ACFS),
2. Installation of the ACFS into a fleet of seven Cessna 172 aircraft owned and operated by Embry-Riddle Aeronautical University (ERAU),
3. Conduct aircraft usage data acquisition on seven Cessna 172 aircraft,
4. Define the effectiveness of ACFS in the data acquisition effort and any required design changes required for the ACFS, and
5. Provide the resultant processed data from the data acquisition effort in formats useful to the FAA.

Presented in this report are the description of the ACFS, the analysis and statistical summaries of the data collected from 1000 flights representing 1168 hours of Cessna 172 aircraft operational data. The end product from the data acquisition effort includes statistical information on acceleration, speeds, altitudes, and flight duration and distance.

1. INTRODUCTION.

Systems & Electronics, Inc. (SEI) completed Phase II of a Federal Aviation Administration (FAA) sponsored Small Business Innovative Research (SBIR) initiative. This report includes a summary of the design, development, manufacturing, and test of a low-cost Airframe Cumulative Fatigue System (ACFS). This report also includes the results of the operational flight and ground load data survey. This report presents acquired, processed, and evaluated statistical flight load data from the Cessna 172 aircraft.

The main objectives of this program were:

- To design, develop, manufacture, and test a low-cost ACFS.
- To use the ACFS to acquire, evaluate, and utilize typical operational in-service data, which can be used in structural fatigue damage reliability analysis of the aircraft.
- To provide a basis to assess the structural condition of the aircraft in an attempt to evaluate any future improvement that may be necessary for the aircraft design.

This phase of the program involved the acquisition and analysis of operational flight and ground load data using the ACFS. The ACFS was installed on a fleet of seven Cessna 172 aircraft. SEI performed all the relevant tasks associated with data compilation, analysis, editing, and preparation of statistical flight load data results.

This report is prepared in accordance with the format provided by the FAA and includes the statistical loads derived from recorded data obtained from seven aircraft. There were a total of about 1000 flights and about 1168 hours of operation. This report contains a brief description of the Cessna 172 aircraft followed by the processes used for data collection, editing, and processing. The statistical formats and aircraft flight usage data in the form of graphs are presented in the appendices.

2. AIRCRAFT DESCRIPTION.

The Cessna 172 is a single engine aircraft with a maximum cruise speed at altitude of 122 knots and a maximum range of about 580-687 nautical miles (nm). Table 1 summarizes certain operational characteristics of the Cessna 172 aircraft equipped with SEI's airframe cumulative fatigue system. An overall view drawing of the aircraft is shown in figure 1, and the aircraft overall dimensions are presented in table 2.

TABLE 1. CESSNA 172—CHARACTERISTICS

(This information is for the Cessna 172R, which is used at Daytona. Prescott operates the 172S, which has slightly different specifications. (see www.cessna.com))

Performance and Descriptions*	
SPEED**	
V _{NE} , never exceed speed	160 KCAS, 163 KIAS
V _{NO} , maximum structural cruising speed	126 KCAS, 129 KIAS
Maximum at Sea Level	123 kts
Cruise, 80% power at 8,000 ft	122 kts
RANGE	
80% power at 8 000 ft	580 nm
60% power at 10 000 ft	687 nm
TIME	
80% power at 8 000 ft	4.8 hrs
60% power at 10 000 ft	6.6 hrs
RATE OF CLIMB AT SEA LEVEL	720 fpm
SERVICE CEILING	13,500 ft
TAKEOFF PERFORMANCE:	
Ground Roll	945 ft
Total distance over 50 ft. obstacle	1,685 ft
LANDING PERFORMANCE:	
Ground Roll	550 ft
Total distance over 50 ft. obstacle	1,295 ft
STALL SPEED (KCAS):	
Flaps off, Power Off	51 KCAS
Flaps down, Power Off	47 KCAS
MAXIMUM WEIGHT:	
Ramp	2,457 lbs
Takeoff or Landing	2,450 lbs
STANDARD EMPTY WEIGHT	1,639 lbs
MAXIMUM USEFUL LOAD	818 lbs
BAGGAGE ALLOWANCE	120 lbs
WING LOADING	14.1 lbs/sq ft
POWER LOADING	15.3 lbs/hp
FUEL CAPACITY	56 US gal
OIL CAPACITY	8 qts
ENGINE: Textron Lycoming (160 BHP at 2400 rpm)	IO-360-L2A
PROPELLER: Fixed Pitch, Diameter	75 in

* Based on airplane weight at 2,450 pounds, standard atmospheric conditions, level, hard-surface dry runways and no wind. Actual individual aircraft performance can be different.

** The speed information is for an airplane equipped with the optional speed fairings, which increase the speeds, by approximately two knots.

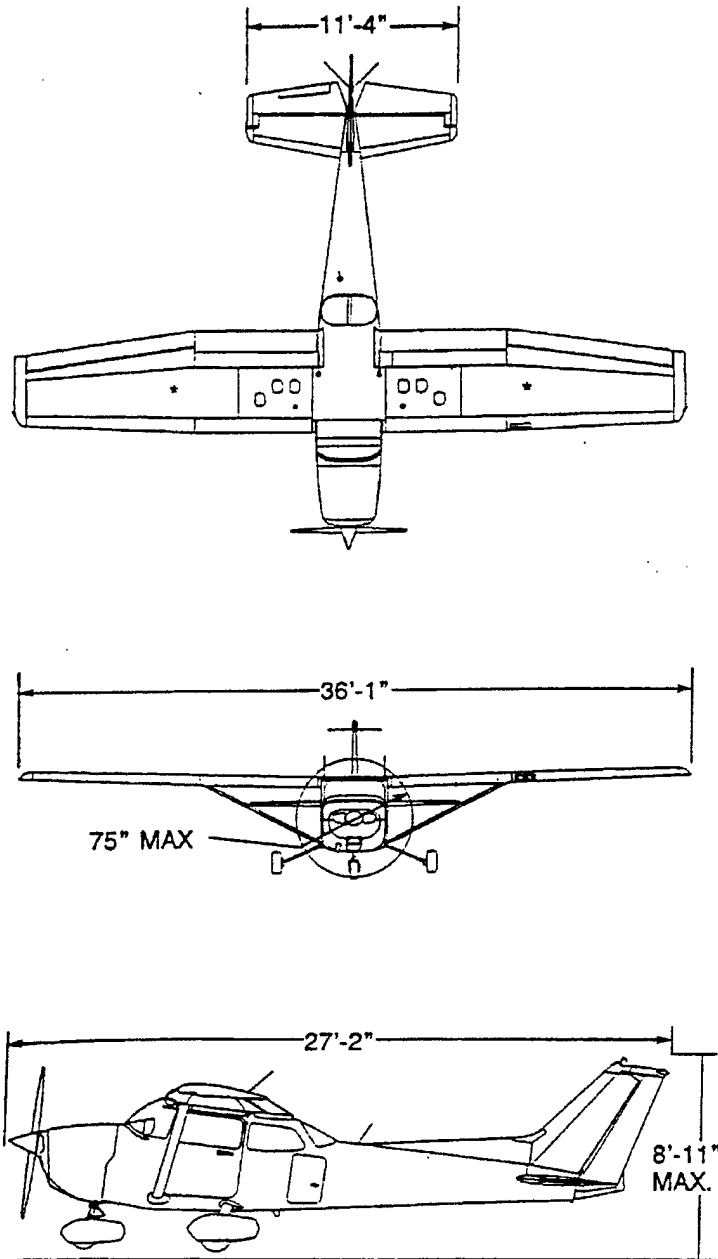

FIGURE 1. CESSNA 172 THREE-VIEW DRAWING [1]

TABLE 2. AIRCRAFT DIMENSIONS

INTERIOR DIMENSIONS (Cabin)	EXTERIOR DIMENSIONS (Overall)
Length: 142 inches	Length: 26 feet, 11 inches
Height: 48 inches	Height: 8 feet, 11 inches
Width: 39.5 inches	Wing Span: 36 feet, 1 inch

3. AIRCRAFT DATA COLLECTION AND EDITING SYSTEM.

3.1 DATA COLLECTION SYSTEM.

Reference 2 describes the ACFS. The low-cost ACFS is capable of recording airspeed, altitude, normal acceleration, roll rates, yaw rates, and pitch rates. The system also supports a global positioning system (GPS) option. The system can monitor and record eight analog and eight digital channels. Airspeed and altitude were measured with Air Data Transducers (ADX), which converted the aircraft's pitot-static pressures into analog signals. The recorder contains 512 Kbytes of FLASH memory that is used to store the recorded parameters. The recorder also includes a real-time clock that is used to time-stamp the data.

The systems were forwarded to Embry-Riddle Aeronautical University (ERAU) to install on their aircraft. ERAU flew the aircraft equipped with the SEI recorders. The airborne recorder recorded the parameters described above. This recorded data was immediately compressed and then stored in an electronic (FLASH) memory. At the end of a flight (or series of flights) the memory module was downloaded into a computer. A decompression algorithm was then used to expand the data into a time-contiguous form.

3.2 DATA EDITING SYSTEM.

The time-contiguous data was examined manually to ensure that all data represented actual flights (or at least aircraft that moved). Data that resulted from power applied and then removed from the recorder without any aircraft movement was eliminated. The recorder was designed to record data from power-up to power-down. Although this generated excessive data, it was determined that it was better to eliminate extraneous data (in postprocessing) than to miss important data during normal operation.

4. SEI DATA PROCESSING.

4.1 RECORDED PARAMETERS.

The flight parameters recorded and extracted directly from the ACFS include the following.

- Altitude
- Airspeed
- Normal acceleration
- Roll rate
- Pitch rate
- Yaw rate

4.2 DERIVED AND EXTRACTED PARAMETERS.

Several parameters were not directly recorded by the ACFS and had to be either derived or extracted from information on aircraft performance limits or from other flight parameters. These parameters are:

- Flight time
- Flight distance
- Flight duration
- Flight phase
- N_z gust
- N_z maneuver
- Derived gust velocity

4.2.1 Identification of Liftoff and Touchdown.

The time of liftoff and touchdown was determined from the flight history. SEI examined the flight history of aircraft and used a rigorous quality assurance program to extract quality data. The ACFS recording system does not provide a weight-on-wheels signal. Changes recorded in normal acceleration (n_z), altitude, indicated airspeed and pitch rate were used as key incidences that can be used to identify the time of liftoff and touchdown. While light aircraft such as the Cessna 172 generally do not require a positive pitch rotation for takeoff, pitch rate was used because a significant change in pitch would likely only occur at or after the point at which the aircraft became airborne. The actual time at liftoff is determined from the pitch rate recorded in the "on-the-ground" data. A change in the pitch rate by more than two degrees per second is defined as liftoff. The time of this event is then recorded. The time of touchdown is measured by examining the changes in the airspeed, n_z , and altitude that indicate a contact with the runway. The pitch rate before and after this time is also used as an indicator of the touchdown occurrence.

4.2.2 Flight Distance.

The flight distance (D) is obtained by numerically integrating true velocity (V_T) from the time of liftoff (t_o) to the time of touchdown (t_n). V_T is the true average velocity during the time increment (Δt).

$$D = \sum_{t_o}^{t_n} \Delta t \times V_T \quad (1)$$

For a perfect speed indicator, the indicated airspeed equals the calibrated airspeed. In this report, the indicated airspeed is assumed to equal the calibrated airspeed. Assuming incompressible flow and neglecting the small effects at low Mach numbers, the true airspeed (V_T) can be described as a function of calibrated airspeed (V_{CAS}) and the square root of the ratio of air density at sea level (ρ_0) to air density at altitude (ρ).

Thus,

$$V_T = V_{CAS} \sqrt{\frac{\rho_0}{\rho}} \quad (2)$$

For altitudes below 36,089 feet, the density, ρ , is expressed as a function of altitude based on the International Standard Atmosphere by

$$\rho = \rho_0 (1 - 6.876 \times 10^{-6} \times H_p)^{4.256} \quad (3)$$

where ρ_0 is air density at sea level (0.0023769 slugs/ft³) and H_p is pressure altitude (ft). Pressure altitude is a recorded parameter.

4.2.3 Flight Duration.

The flight duration is defined as the time from aircraft liftoff to touchdown.

4.2.4 Design Load Factor Definition.

The gust and maneuver load spectra specified in Department of Transportation Report AFS-120-73-2 [3], are expressed in terms of a load factor ratio, A_{NLLF} . AFS-120-73-2 defines this ratio as the incremental load factor at operating weight divided by the incremental design limit load factor at maximum gross weight. Therefore, in order to compare the Cessna 172 gust and maneuver flight load factor spectra with the AFS-120-73-2 flight load spectra, the aircraft design limit load factor for gust had to be estimated.

For the gust spectra comparison, the incremental gust design limit load factor is specified in AFS120-73-2 as follows:

$$A_{NLLF} = \frac{30KVm}{498 \times W/S} \quad (4)$$

$$K = \frac{1}{2} (W/S)^{\frac{1}{4}} \quad \text{for } W/S < 16 \text{ psf} \quad (5)$$

$$K = 1.33 - \left(\frac{2.67}{(W/S)^{\frac{3}{4}}} \right) \quad \text{for } W/S > 16 \text{ psf} \quad (6)$$

V = Airplane design cruising speed V_c , knots

m = Lift curve slope, C_L per radian

W/S = Wing loading at maximum gross weight, psf

For the maneuver spectra, from the Cessna Information Manual for the 172R Aircraft [1], the positive load factor and negative load factor are as follows:

FLIGHT LOAD FACTOR LIMITS

NORMAL CATEGORY

Flight Load Factors (maximum takeoff weight - 2450 lbs.):

*Flaps up.....+3.8g, -1.52g

*Flaps down.....+3.0g

*The design load factors are 150% of the above, and in all cases, the structure meets or exceeds design loads.

UTILITY CATEGORY

Flight Load Factors (maximum takeoff weight - 2100 lbs.):

*Flaps up.....+4.4g, -1.76g

*Flaps down.....+3.0g

*The design load factors are 150% of the above, and in all cases, the structure meets or exceeds design loads.

For the normal positive incremental load factor:

$$\text{Flaps up: } 3.8g - 1g = 2.8g$$

$$\text{Flaps down: } 3.0g - 1g = 2g$$

For the negative incremental load factor:

$$\text{Flaps up: } -1.58g - 1g = -2.58g$$

For the utility positive incremental load factor:

$$\text{Flaps up: } 4.4g - 1g = 3.4g$$

$$\text{Flaps down: } 3.0g - 1g = 2g$$

For the negative incremental load factor:

$$\text{Flaps up: } -1.76g - 1g = -2.76g$$

4.2.5 Derived Gust Velocity.

Derived gust velocity is an important statistical load parameter, which can be derived from measured normal accelerations. The calculation of derived gust velocity from measured normal accelerations requires knowledge of atmospheric density, equivalent airspeed, dynamic pressure, and the lift curve slope. The derived gust velocity, U_{de} , is computed from the peak values of gust incremental normal acceleration as

$$U_{de} = \frac{\Delta n_z}{\bar{C}} \quad (8)$$

where Δn_z is gust peak incremental normal acceleration and \bar{C} is the aircraft response factor considering the plunge-only degree of freedom and is calculated from

$$\bar{C} = \frac{\rho_0 V_e C_{l_\alpha} S}{2W} K_g \quad (9)$$

where

- ρ_0 = 0.002377 slugs/ft³, standard sea level air density
- V_e = equivalent airspeed (ft/sec)
- C_{l_α} = aircraft lift curve slope per radian
- S = wing reference area (ft²)
- W = gross weight (lbs)
- K_g = $\frac{0.88\mu}{5.3 + \mu}$ = Gust alleviation factor
- μ = $\frac{2W}{\rho g c C_{l_\alpha} S}$
- ρ = air density, slug/ft³, at pressure altitude (H_p), from equation 3
- g = 32.17 ft/sec²
- \bar{c} = wing mean geometric chord (ft)

Equivalent airspeed (V_e) is a function of true airspeed (V_T) and the square root of the ratio of air density at altitude (ρ) to air density at sea level (ρ_0)

$$V_e = V_T \sqrt{\frac{\rho}{\rho_0}} \quad (10)$$

For altitudes below 36,089 feet, the density, ρ , is expressed as a function of altitude based on the International Standard Atmosphere by

$$\rho = \rho_0 (1 - 6.876 \times 10^{-6} \times H_p)^{4.256}$$

where ρ_0 is air density at sea level (0.0023769 slugs/ft³) and H_p is pressure altitude (ft). Pressure altitude is a recorded parameter.

The dynamic pressure (q) is calculated from the air density and velocity

$$q = \frac{1}{2} \rho V_T^2 \quad (11)$$

where

ρ = air density at altitude (slugs/ft³)

V_T = true airspeed (ft/sec)

For this study, the wing lift curve slope (C_{l_α}) was obtained from reference 3 as follows:

$$C_{l_\alpha} = \frac{2\pi A_r}{2 + \left(4 + A_r^2 \beta^2 \left(1 + \frac{\tan^2 \Lambda}{\beta^2} \right) \right)^{1/2}} \quad (12)$$

A_r = $\frac{b^2}{S}$ = wing aspect ratio

b = wing span

β = $\sqrt{1 - M^2}$

C_{l_α} = wing lift curve slope per radian

Λ = quarter chord sweep angle

M = Mach number

Mach number is derived from true airspeed and the speed of sound (a):

$$M = \frac{V_T}{a} \quad (13)$$

The speed of sound (a) is a function of pressure altitude (H_p) and the speed of sound at sea level and is

$$a = a_0 \sqrt{(1 - 6.876 \times 10^{-6} \times H_p)} \quad (14)$$

thus

$$M = \frac{V_T}{a_0 \sqrt{(1 - 6.876 \times 10^{-6} \times H_p)}}$$

where the speed of sound at sea level a_0 is 1116.4 fps or 661.5 knots.

Equation 12 provides an estimate of the wing lift curve slope. Airplane gust response calculations are based on the use of the airplane lift curve slope. Reference 3 uses an average factor of 1.15 to represent the ratio between the BE-1900D airplane lift curve slope and the wing lift curve slope. However, a more appropriate value for the Cessna 172 is 1.07, and this value will be used for derived gust velocity computations. In this case, the wing lift curve slope, C_{l_α} , is the untrimmed rigid lift curve slope for the entire aircraft.

4.3 DATA REDUCTION.

The following paragraphs describe the procedures SEI used to process the recorded parameters.

4.3.1 Initial Quality Screening.

All incoming data files are screened for missing or incomplete data before being accepted into the final database. Individual flights are edited to remove erroneous or meaningless data such as discontinuous elapsed time data, evidence of nonfunctional channels or sensors, multiple flights on one file, and incomplete flight phases. Flight files with missing or incomplete data are identified and rejected from the final database.

The data generated by the ground processing software in section 4.1 was once again examined manually. Values that were obviously erroneous were removed. For example, occasionally there would be an airspeed value of 500 knots or an altitude of 20,000 feet. Values such as these could have been generated as a result of a noise spike and were subsequently eliminated.

4.3.2 Time History Files.

A Microsoft Corporation (MS) Visual Basic for Applications (VBA) program was written to run in MS Excel to read the data generated by the ground processing software in section 4.1 into spreadsheets and tabulate/reduce the data, which was then plotted using Synergy KaleidaGraph. This data is presented in appendices A through C.

4.3.3 Relational Database.

Important characteristics about each set of flights are recorded in a relational database. Aircraft location, aircraft tail number, and other data are in the database. Each flight was identified uniquely.

4.4 DATA REDUCTION CRITERIA.

To process the measured data into statistical flight loads format, specific data reduction criteria were established for each parameter. These criteria are discussed in this section.

4.4.1 Ground/Flight Phases of Recorded Data.

The in-flight duration is defined as the time from liftoff to touchdown. Within the recorded data, nine different operational phases are identified. These include:

1. Taxi out
2. Takeoff roll
3. Departure
4. Climb
5. Cruise
6. Descent
7. Approach
8. Landing roll
9. Taxi in

Figure 2 illustrates a profile of these nine phases. The best combination of the airspeed, altitude, pitch rate, and the normal acceleration can identify the change from one phase to the other.

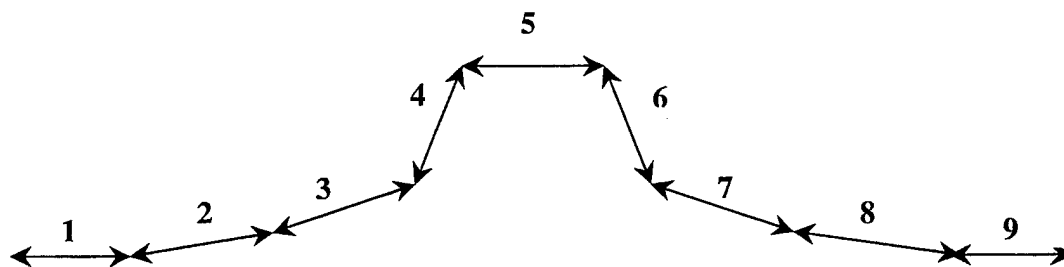

FIGURE 2. DESCRIPTION OF FLIGHT PHASES

4.4.2 Sign Convention.

Acceleration data are recorded in the normal (z) direction. The positive direction is up. The positive pitch rate direction is nose up. The positive roll rate direction is to the right (right wing down). The positive yaw rate direction is to the right (nose right).

4.4.3 Peak-Valley Selection.

Normal acceleration was recorded with a count range of 256 representing an acceleration range of ± 5 g. To identify peaks and valleys in postprocessing, a deadband was established of ± 1 count (10 g/256 or 0.039 g) around the 1-g value. A peak or valley is verified as the maximum excursion outside of the deadband prior to the acceleration data crossing into or through the deadband.

4.4.4 Separation of Maneuver and Gust Load Factors.

The incremental acceleration measured at the center of gravity (c.g.) of the aircraft may be the result of either maneuvers or gusts. In order to derive gust and maneuver statistics, the maneuver induced acceleration and gust response accelerations must be separated from the total acceleration history. Reference 3 cites a study to evaluate methods of separating maneuver and gust load factors from measured acceleration time histories. As a result of this study, it was recommended and accepted by the FAA that a cycle duration rule be used to separate gusts and maneuvers. A cycle duration of 1.0 seconds was recommended for use with Cessna 172 aircraft. In order to avoid the inclusion of peaks and valleys associated with very small load variations that are insignificant to the aircraft structure, a deadband zone of $\Delta n_z = \pm 0.05$ g was established. An algorithm was then developed to extract the acceleration peaks and valleys.

For each flight, the maximum and minimum total accelerations were determined from just after liftoff to just before touchdown. For the in-flight phases, the Δn_z cumulative occurrences were determined as cumulative counts per nautical mile and cumulative counts per 1000 hours using the peak-between-means counting method as done in reference 3. The measurements of Δn_z , $\Delta n_{z_{gust}}$, and $\Delta n_{z_{man}}$ are maintained as three unique data streams. The Δn_z , $\Delta n_{z_{gust}}$, and $\Delta n_{z_{man}}$ data are plotted as cumulative occurrences of a given acceleration increment per nautical mile and per 1000 flight hours. The incremental normal load factor Δn_z is the airplane limit load factor minus 1.0 g. As a result of the threshold zone, only accelerations greater than ± 0.05 g (measured from a 1.0-g base) are counted for data presentation.

4.4.5 Altitude Bands.

In preparing the data summaries, the maximum altitude ranges as summarized in table 3 are used.

TABLE 3. ALTITUDE BANDS

Altitude Bands	
Band Number	Altitude Range (ft)
1	0-500
2	500-1,000
3	1,000-1,500
4	1,500-2,000
5	2,000-2,500
6	2,500-3,000
7	3,000-3,500
8	3,500-4,000
9	4,000-4,500
10	4,500-5,000
11	5,000-5,500
12	5,500-6,000
13	6,000-6,500
14	6,500-7,000
15	7,000-7,500
16	7,500-8,000
17	8,000-8,500
18	8,500-9,000
19	9,000-9,500
20	9,500-10,000
21	10,000-10,500
22	10,500-11,000
23	11,000-11,500
24	11,500-12,000
25	12,000-12,500
26	12,500-13,000
27	13,000-13,500
28	13,500-14,000
29	14,000-14,500
30	14,500-15,000

The flight distances were grouped in six ranges as summarized in table 4.

TABLE 4. FLIGHT DISTANCE RANGES (nm)

Distance Bands	
Range Number	Distance (nm)
1	0-50
2	50-100
3	100-150
4	150-200
5	200-250
6	>250

4.4.6 Vertical Acceleration Bias Correction.

For a flight, any bias occurring in the vertical (i.e., normal) acceleration measurement is removed by adjusting the difference between a known 1-g level and the actual acceleration recorded value. That is to say, bias was determined by noting the recorded vertical acceleration value while the aircraft was at rest. This difference is the correction/bias that will be added/subtracted from all measured load factor values for the flight.

5. DATA PRESENTATION.

This section presents statistical summaries of aircraft usage data, ground loads data, and flight loads data collected from the Cessna 172 aircraft during typical training usage. Statistical data are presented for parameters such as gust and maneuver acceleration, airspeed, altitude, flight duration and distance, derived gust velocity, V-n diagrams, and vertical acceleration during ground operations. These data were reduced and processed into statistical formats that are typically used in presenting this type of data. These data can then be used by the FAA and the aircraft manufacturer to assess existing certification criteria contained in the FAA's Federal Aviation Regulation (FAR) or by the aircraft manufacturer to better understand and control those factors that influence the structural integrity of the aircraft.

During data editing, it was found that the recorded data for certain flights/aircraft exhibited random errors and were unreliable. When this occurred, statistical data for any parameters associated, directly or indirectly, with the unreliable measurements from those flights and in some cases all data from that aircraft were eliminated from the database.

Table 5 contains a list of the statistical data formats and identifies the corresponding figure where the processed data plot or table can be found in appendices A, B, and C. Appendix A includes all aircraft, appendix B includes aircraft based at Daytona, and appendix C includes aircraft based at Prescott. The figure numbers shown in the format "-n" are in each appendix as A-n, B-n, and C-n. The figures have been grouped into categories identified as aircraft usage, ground loads, flight loads, gust loads, maneuver loads, combined maneuver, and gust loads. Each figure is discussed in the following paragraphs.

5.1 AIRCRAFT USAGE DATA.

The aircraft usage data include flight profile statistics such as altitudes, speeds, and flight distance information. This information is useful for deriving typical flight profiles; for defining loading spectra for structural fatigue, durability, and damage tolerance analyses; and for developing future design criteria. Aircraft usage data are presented in figures A-, B-, and C-1 through A-, B-, and C-10.

TABLE 5. STATISTICAL FORMATS

AIRCRAFT USAGE DATA	Figure
Correlation of Maximum Altitude and Flight Distance, Percent of Flights	A-, B-, C-1
Percent of Total Distance in Altitude Bands	A-, B-, C-2
Coincident Flight Distance and Maximum Flight Altitude	A-, B-, C-3
Coincident Altitude at Maximum Indicated Airspeed, All Flight Phases	A-, B-, C-4
Maximum Speed and Coincident Altitude During Climb	A-, B-, C-5
Maximum Speed and Coincident Altitude During Cruise	A-, B-, C-6
Maximum Speed and Coincident Altitude During Descent	A-, B-, C-7
Maximum Speed and Coincident Altitude During all Flight Phases	A-, B-, C-8
Number of Flights vs Flight Duration	A-, B-, C-9
Cumulative Probability of Flight Duration	A-, B-, C-10
GROUND LOADS DATA	
Cumulative Probability of Airspeed at Liftoff and Touchdown	A-, B-, C-11
Cumulative Probability of Pitch Rate at Liftoff	A-, B-, C-12
Cumulative Frequency of Incremental Vertical Load Factor During Taxi Operations	A-, B-, C-13
Cumulative Occurrences of Incremental Vertical Load Factor During Takeoff Roll	A-, B-, C-14
Cumulative Occurrences of Incremental Vertical Load Factor During Landing Roll	A-, B-, C-15
FLIGHT LOADS DATA	
GUST LOADS DATA	
Cumulative Occurrences of Incremental Gust Load Factor per 1000 Hours by Pressure Altitude for Combined Climb, Cruise, and Descent Phases	A-, B-, C-16
Cumulative Occurrences of Incremental Gust Load Factor per Nautical Mile by Pressure Altitude for Combined Climb, Cruise, and Descent Phases	A-, B-, C-17
Cumulative Occurrences of Incremental Gust Load Factor per 1000 Hours by Altitude Above Airport for Departure Phase	A-, B-, C-18
Cumulative Occurrences of Incremental Gust Load Factor per Nautical Mile by Altitude Above Airport for Departure Phase	A-, B-, C-19
Cumulative Occurrences of Incremental Gust Load Factor per 1000 Hours by Altitude Above Airport for Approach Phase	A-, B-, C-20
Cumulative Occurrences of Incremental Gust Load Factor per Nautical Mile by Altitude Above Airport for Approach Phase	A-, B-, C-21
Cumulative Occurrences of Incremental Gust Load Factor per 1000 Hours, Combined Flight Phases	A-, B-, C-22
Cumulative Occurrences of Incremental Gust Load Factor per Nautical Mile	A-, B-, C-23
Cumulative Occurrences of Derived Gust Velocity per Nautical Mile for < 2000 Feet	A-, B-, C-24
Cumulative Occurrences of Derived Gust Velocity per Nautical Mile for 2000-4000 Feet	A-, B-, C-25
Cumulative Occurrences of Derived Gust Velocity per Nautical Mile for 4000-6000 Feet	A-, B-, C-26

TABLE 5. STATISTICAL FORMATS (Continued)

FLIGHT LOADS DATA (Continued)	Figure
GUST LOADS DATA (Continued)	
Cumulative Occurrences of Derived Gust Velocity per Nautical Mile for 6000-8000 Feet	A-, B-, C-27
Cumulative Occurrences of Derived Gust Velocity per Nautical Mile for >8000 Feet	A-, B-, C-28
Coincident Gust Load Factor and Speed vs V-n Diagram During Departure	A-, B-, C-29
Coincident Gust Load Factor and Speed vs V-n Diagram During Approach	A-, B-, C-30
MANEUVER LOADS DATA	
Cumulative Occurrences of Incremental Maneuver Load Factor per 1000 Hours by Pressure Altitude for Combined Climb, Cruise, and Descent Phases	A-, B-, C-31
Cumulative Occurrences of Incremental Maneuver Load Factor per Nautical Mile by Pressure Altitude for Combined Climb, Cruise, and Descent Phases	A-, B-, C-32
Cumulative Occurrences of Incremental Maneuver Load Factor per 1000 Hours by Altitude Above Airport for Departure Phase	A-, B-, C-33
Cumulative Occurrences of Incremental Maneuver Load Factor per Nautical Mile by Altitude Above Airport for Departure Phase	A-, B-, C-34
Cumulative Occurrences of Incremental Maneuver Load Factor per 1000 Hours by Altitude Above Airport for Approach Phase	A-, B-, C-35
Cumulative Occurrences of Incremental Maneuver Load Factor per Nautical Mile by Altitude Above Airport for Approach Phase	A-, B-, C-36
Comparison of Cumulative Occurrences of Incremental Maneuver Load Factor per Nautical Mile, Cessna 172 vs AFS-120-73-2	A-, B-, C-37
COMBINED MANEUVER AND GUST LOADS DATA	
Cumulative Occurrences of Incremental Load Factor per 1000 Hours by Pressure Altitude for Combined Climb, Cruise, and Descent Phases	A-, B-, C-38
Cumulative Occurrences of Incremental Load Factor per Nautical Mile by Pressure Altitude for Combined Climb, Cruise, and Descent Phases	A-, B-, C-39
Cumulative Occurrences of Incremental Load Factor per 1000 Hours by Altitude Above Airport for Departure Phase	A-, B-, C-40
Cumulative Occurrences of Incremental Load Factor per Nautical Mile by Altitude Above Airport for Departure Phase	A-, B-, C-41
Cumulative Occurrences of Incremental Load Factor per 1000 Hours by Altitude Above Airport for Approach Phase	A-, B-, C-42
Cumulative Occurrences of Incremental Load Factor per Nautical Mile by Altitude Above Airport for Approach Phase	A-, B-, C-43
Cumulative Occurrences of Incremental Load Factor per 1000 Hours for Combined Flight Phases	A-, B-, C-44

5.1.1 Altitude and Flight Distance Data.

Measured operational altitudes and their correlation to flight distance are presented. The table in figures A-, B-, and C-1 show the correlation between the maximum altitude attained in flight and the flight distance flown in percent of flights. Figures A-, B-, and C-2 present the percent of

total flight distance spent in various altitude bands as a percent of flight distance. The flight distances in figures A-, B-, and C-2 do not reflect the actual stage lengths or great circle distances between departure and arrival location but do reflect the actual distances flown based on the numerical integration approach mentioned in paragraph 4.2.3. Deviation from direct flight between departure and arrival points resulting from traffic control requirements will increase the actual distance flown by some unknown amount. To a much lesser extent, the climb and descent distances are slightly larger than the level flight distance. Head or tail winds also are unknown contributors. The integrated distance accounts for such variables. The combined information in figures A-, B-, and C-1 and A-, B-, and C-2 provide a useful picture of the flight profile distribution.

5.1.2 Coincident Airspeed and Altitude Data.

Flight distance and altitude statistics are useful in the generation of flight profiles. Figures A-, B-, and C-3 show the maximum altitude reached for each flight and the corresponding distance flown for that flight. Figures A-, B-, and C-4 contain a line intersecting the x axis at 160 knots, which represents the never exceed speed (V_{NE}). The data points were generated by locating the airspeed and corresponding altitude during each flight where the aircraft came the closest to this limit condition.

5.1.3 Maximum Operating Airspeed Data.

The maximum speed attained by coincident altitude and by phase of flight is very useful in obtaining a picture of the flight speed profile. Figures A-, B-, and C-5, through A-, B-, and C-7 present the maximum airspeed attained for the climb, cruise, and descent phases of flight by altitude. Figures A-, B-, and C-8 show the data for all the flight phases combined. Each data point represents the maximum airspeed attained within each 500-foot band of altitude; therefore, the actual point is plotted for the maximum speed and the corresponding altitude where the maximum speed occurred. For each plot, the never exceed speed line (V_{NE}) is depicted as obtained from reference 1.

5.1.4 Flight Duration.

Flight duration is also important in the generation of flight profiles. The bar chart in figures A-, B-, and C-9 contain a breakdown of the number of flights flown versus the time duration of each flight from takeoff to landing. Figures A-, B-, and C-10 present the same flight duration data in a cumulative probability format. It should be noted that that these aircraft are used for training and that aircraft used for other missions might well have a different average flight duration.

5.2 GROUND LOADS DATA.

The ground loads data include frequency and probability information on vertical acceleration, speeds, and pitch rate associated with takeoff, landing, and ground operations. These data are of primary importance to landing gear and landing gear backup structure, and to a lesser extent, to the wing, fuselage, and empennage. Ground load data are presented in figures A-, B-, and C-11 through A-, B-, and C-15.

5.2.1 Airspeed at Liftoff and Touchdown.

Figures A-, B-, and C-11 show the cumulative probabilities of airspeed at liftoff and at touchdown.

5.2.2 Pitch Rate at Liftoff.

Information about pitch rate is useful as a performance parameter. Although it alone cannot indicate the pitch attitude of the aircraft, it serves to indicate a change in pitch. The cumulative probability of pitch rate at the instant of liftoff is shown in figures A-, B-, and C-12.

5.2.3 Load Factor Data During Ground Operations.

The cumulative frequencies of vertical load factor are presented for the ground phases of operations. These data are useful for calculating loads on the landing gear and the backup structure. Figures A-, B-, and C-13 present vertical load factor during taxi operations broken out by taxi in and out. Figures A-, B-, and C-14 show these data during the takeoff roll. Figures A-, B-, and C-15 present these data during the landing roll phase of flight.

5.3 FLIGHT LOADS DATA.

The flight loads data presented in this section include statistical formats that describe the gust, maneuver, and combined maneuver and gust loads environment. For these loading conditions, the normal acceleration data have been plotted in two ways: (1) as cumulative occurrences per 1000 hours and (2) as cumulative occurrences per nautical mile.

5.3.1 Gust Loads Data.

The gust loads data are presented as cumulative occurrences of vertical gust load factor and as cumulative occurrences of derived gust velocity per nautical mile. Coincident gust load factor and speed data are presented on representative V-n diagrams for the approach and departure phases of flight. The V-n diagrams depict the maximum flap extended speed (V_{FE}) for partial flap extension, for reference only, and it must be noted that the ACFS system did not have flap position data. The gust loads data are presented in Figures A-, B-, and C-16 through A-, B-, and C-30.

5.3.1.1 Gust Load Factor Data.

Figures A-, B-, and C-16 present the cumulative occurrences of incremental vertical gust load factor per 1000 hours by pressure altitude for the combined climb, cruise, and descent phases of flight; figures A-, B-, and C-17 present these same data per nautical mile. Figures A-, B-, and C-18 through A-, B-, and C-21 show the cumulative occurrences of incremental vertical gust load factor for the departure and approach phases of flight by altitude above the airport. Data presented in this format will be more influenced by turbulence resulting from ground effect.

5.3.1.2 Gust Load Factor Data, Combined Flight Phases.

Figures A-, B-, and C-22 and A-, B-, and C-23 show the severity of vertical load factor for gust for the Cessna 172 during routine operations.

5.3.1.3 Gust Velocity Data.

The derived gust velocity, U_{de} , was computed from the measured gust acceleration data using the equations described in section 4.2.5. Figures A-, B-, and C-24 through A-, B-, and C-28 show the cumulative occurrences of derived gust velocity per nautical mile for selected altitude levels.

5.3.1.4 V-n Diagrams.

Figures A-, B-, and C-29 show the coincident gust load factor and airspeed plotted with respect to the illustrated gust V-n diagram for the departure phase. The V-n diagrams in figures A-, B-, and C-29 are shown for illustration only. Figures A-, B-, and C-30 present the coincident gust load factor and airspeed during approach. Since the flap position was unknown, a representative V-n diagram could not be presented.

5.3.2 Maneuver Loads Data.

The maneuver loads data are presented as cumulative occurrences of incremental vertical load factor per 1000 hours and per nautical mile by altitude for various phases of flight. The maneuver loads data are presented in figures A-, B-, and C-31 through A-, B-, and C-37. Figures A-, B-, and C-31 and A-, B-, and C-32 present the cumulative occurrences of maneuver load factor per 1000 hours and per nautical mile by pressure altitude for the combined climb, cruise, and descent flight phases. Figures A-, B-, and C-33 and A-, B-, and C-34 present the total cumulative occurrences of incremental maneuver load factor per 1000 hours and per nautical mile for the departure phase of flight by altitude above the airport. Figures A-, B-, and C-35 and A-, B-, and C-36 show the same information for the approach phase of flight. Figures A-, B-, and C-37 show this data for combined altitudes and flight phases.

5.3.3 Combined Maneuver and Gust Loads Data.

For the statistical data presented in this section, the maneuver and gust load factors were not separated, but the total load factor occurrences regardless of the cause were used in the derivation of the figures. The combined maneuver and gust loads data are presented as cumulative occurrences of incremental vertical load factor per 1000 hours and per nautical mile by altitude for various phases of flight. Also, comparisons of usage were made between individual aircraft within the fleet of instrumented aircraft.

5.3.3.1 Combined Maneuver and Gust Load Factor Data.

Figures A-, B-, and C-38 and A-, B-, and C-39 show the cumulative occurrences of total combined maneuver and gust normal load factor per 1000 hours and per nautical mile for the combined climb, cruise, and descent phases of flight by pressure altitude. Figures A-, B-, and C-40 and A-, B-, and C-41 show the combined cumulative acceleration occurrences for the

departure phase by altitude above airport, while figures A-, B-, and C-42 and A-, B-, and C-43 show similar data for the approach phase.

The combined cumulative occurrences of incremental load factor for maneuver and gust are presented for all the flight phases combined in figures A-, B-, and C-44.

5.3.3.2 Comparison of Individual Aircraft Usage.

Table 6 shows the amount of data available for each aircraft by tail number.

TABLE 6. FLIGHT CHARACTERISTICS OF SURVEYED AIRCRAFT

	Daytona Airplanes	Prescott Airplanes
Total Flight Hours	882.3 hours	336.6 hours
Percentage of flights with altitude < 5,000 ft.	94.0	31.0
Percentage of flights with distance < 50 nm.	62.0	75.0

5.3.3.3 Flight Distance Operation.

As would be expected for this type aircraft, the acquired flight data reveals that a rather large percentage of flight operations occurred below an altitude of 10,000 feet. Most flights had a flight distance of 150 nautical miles (nm) or less, with only a few flights with distances longer than 150 nm. Table 6 summarizes the percentage of flights with altitudes below 10,000 feet by aircraft. This table also summarizes the total flight hours and percentage of flights with distances of 150 nm or less.

5.3.3.4 Airspeed Operation.

The data indicate that the seven aircraft primarily operated at the 100-140 knot range. The average airspeed during flight operation was 118 knots. For normal operating conditions with a maximum weight of 2450 lbs., the aircraft manual (reference 1) specifies a range of about 110 to 115 knots. As indicated in the manual, variations in these maximum ranges are expected for a given aircraft. In addition to the maximum weight, other factors such as engine rpm and pressure altitude may affect the maximum airspeed during flight. The ranges specified are for an engine rpm of 2,250 and a pressure altitude of 2,000 to 12,000 feet.

6. CONCLUSIONS AND RECOMMENDATIONS.

SEI successfully developed an ACFS system. SEI, together with ERAU, acquired over 1000 flight hours of data for the Cessna 172 Aircraft. This was accomplished with a low-cost data acquisition system. As a result of this effort, SEI has several recommendations to improve the program for the next phase.

TABLE 7. OPERATIONAL LOAD MONITORING—CESSNA 172
(Concerns and Solutions)

Concerns	Solutions
It was difficult to determine takeoffs and landings.	<ul style="list-style-type: none"> • Incorporate the optional GPS system to determine small changes in altitude, which in turn can indicate takeoff and landing. The GPS system is accurate to within a few meters.
More accuracy was needed for indicated airspeed at low speeds.	<ul style="list-style-type: none"> • Either increase the analog-to-digital converter resolution from 8 to 12 bits or rescale the indicated airspeed range from 0 to 140 knots.
The FLASH memory module did not hold enough data. The memory module filled up too quickly and therefore, downloads were required too frequently.	<ul style="list-style-type: none"> • Increase the FLASH memory module size from 0.5 megabytes to 64 megabytes.
The download process took too much time; it was cumbersome to perform and required either aircraft power or a separate battery box.	<ul style="list-style-type: none"> • Use removable FLASH memory cards that can read by any Windows PC that supports PCMCIA cards. This would completely eliminate the download procedure.
Add position information to the recorded parameters.	<ul style="list-style-type: none"> • Adding a GPS receiver to the system is a low-cost solution that will provide accurate position and time-stamp information.

In order to make the ACFS system more marketable, a removable FLASH memory module must replace the internal FLASH memory. Other minor improvements such increased resolution and more recorded parameters would enhance the product.

7. REFERENCES.

1. Cessna 172R Information Manual, Cessna Aircraft Wichita, Kansas, 1996.
2. Olkiewicz, C., Mohammadi, J., and Cicero, J., "Design Manufacture and Test of a Flight Load Recorder for Small Aircraft," DOT/FAA/CT-TN93/23. Federal Aviation Administration, William J. Hughes Technical Center, Atlantic City International Airport, N.J., February 1994.
3. Tipps, D.O., Skinn, D.A., Rustenburg, J.W., and Zeiler, T.A., "Statistical Loads Data for BE-1900D Aircraft in Commuter Operations," DOT/FAA/AR-00/11, Federal Aviation Administration, William J. Hughes Technical Center, Atlantic City International Airport, N.J., April 2000.

APPENDIX A—STATISTICAL FORMATS, AIRCRAFT USAGE DATA, ALL AIRCRAFT

		Maximum Altitude (1000 feet)			Total
		0-5	5-10	10-15	
Flight Distance (nm)	0-50	48%	20%	0%	68%
	50-100	16%	10%	0%	26%
	100-150	4%	2%	0%	6%
	150-200	0%	1%	0%	1%
	200-250	0%	0%	0%	0%
	250-300	0%	0%	0%	0%
	300-350	0%	0%	0%	0%
	350-400	0%	0%	0%	0%
	400-450	0%	0%	0%	0%
	Total	67%	33%	0%	100%

FIGURE A-1. CORRELATION OF MAXIMUM ALTITUDE AND FLIGHT DISTANCE, PERCENT OF FLIGHTS

		Total Flight Distance (nm)								
		0-50	50-100	100-150	150-200	200-250	250-300	300-350	350-400	400-450
Altitude Band (feet)	0-5k	71%	60%	67%	33%	0%	0%	0%	0%	0%
	5k-10k	29%	40%	33%	67%	0%	0%	0%	0%	0%
	10k-15k	0%	0%	0%	0%	0%	0%	0%	0%	0%
	Total	100%	100%	100%	100%	0%	0%	0%	0%	0%
	Number of Flights	540	206	45	9	0	0	0	0	0

FIGURE A-2. PERCENT OF TOTAL DISTANCE IN ALTITUDE BANDS

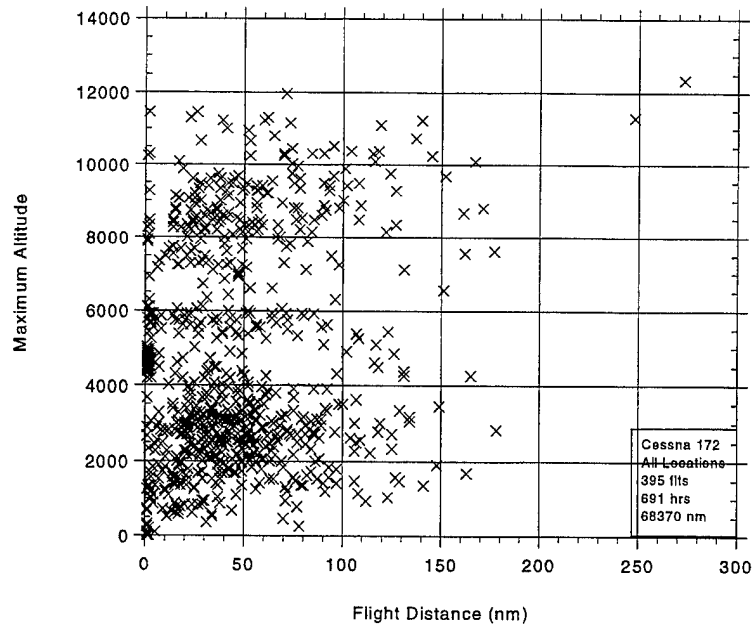

FIGURE A-3. COINCIDENT FLIGHT DISTANCE AND MAXIMUM FLIGHT ALTITUDE

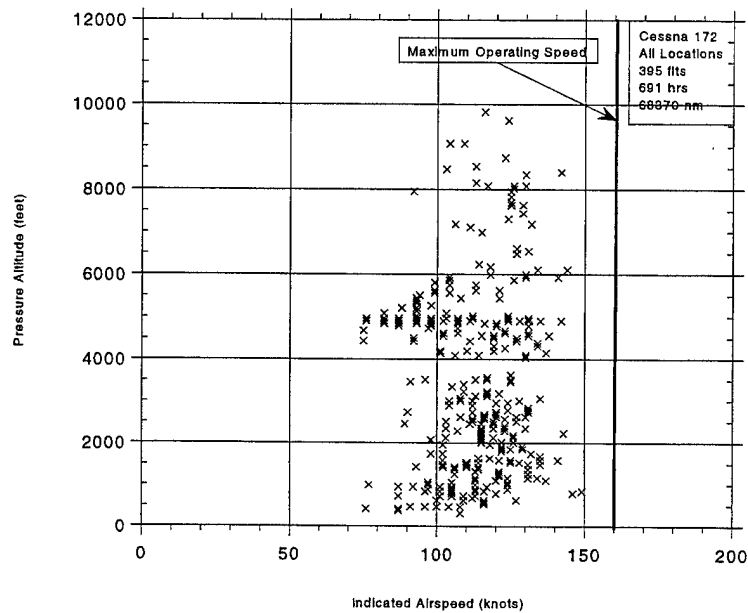

FIGURE A-4. COINCIDENT ALTITUDE AT MAXIMUM INDICATED AIRSPEED, ALL FLIGHT PHASES

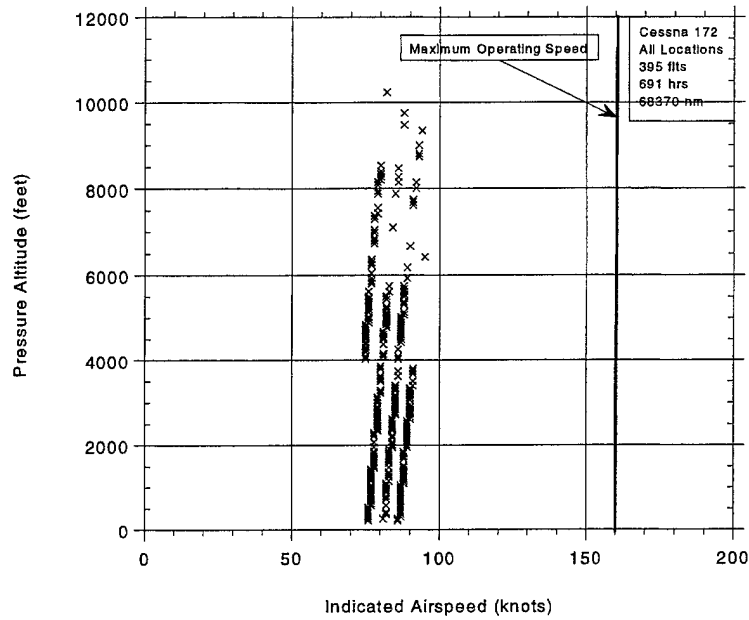

FIGURE A-5. MAXIMUM SPEED AND COINCIDENT ALTITUDE DURING CLIMB

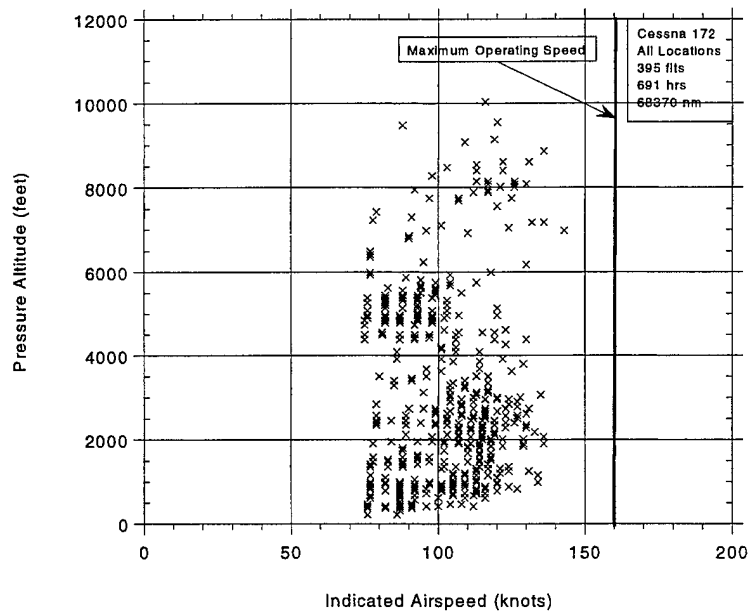

FIGURE A-6. MAXIMUM SPEED AND COINCIDENT ALTITUDE DURING CRUISE

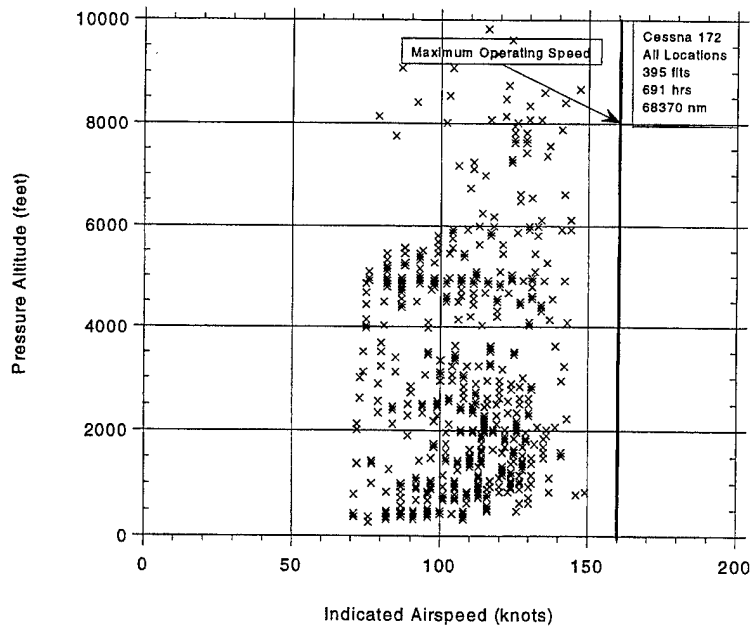

FIGURE A-7. MAXIMUM SPEED AND COINCIDENT ALTITUDE DURING DESCENT

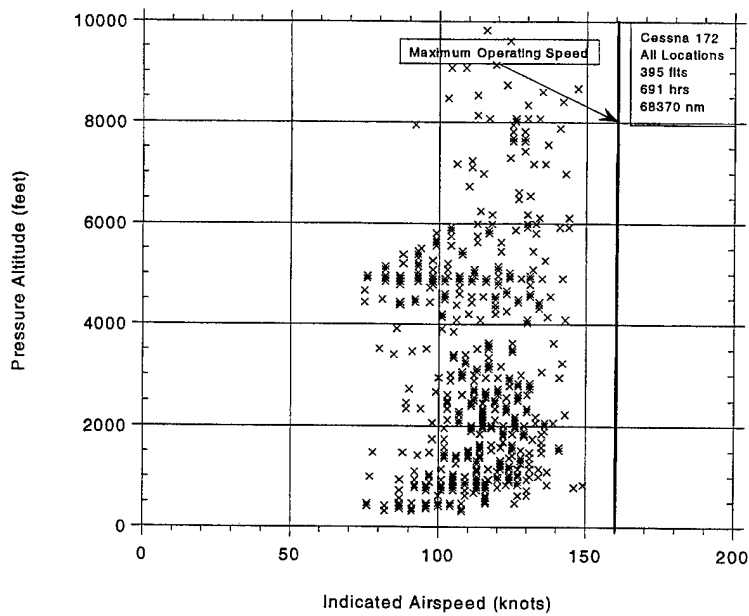

FIGURE A-8. MAXIMUM SPEED AND COINCIDENT ALTITUDE DURING ALL FLIGHT PHASES

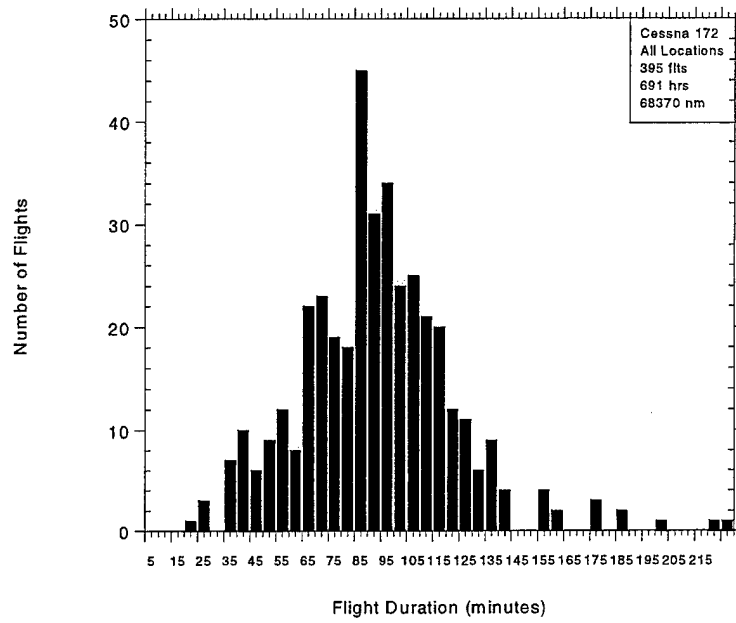

FIGURE A-9. NUMBER OF FLIGHTS VS FLIGHT DURATION

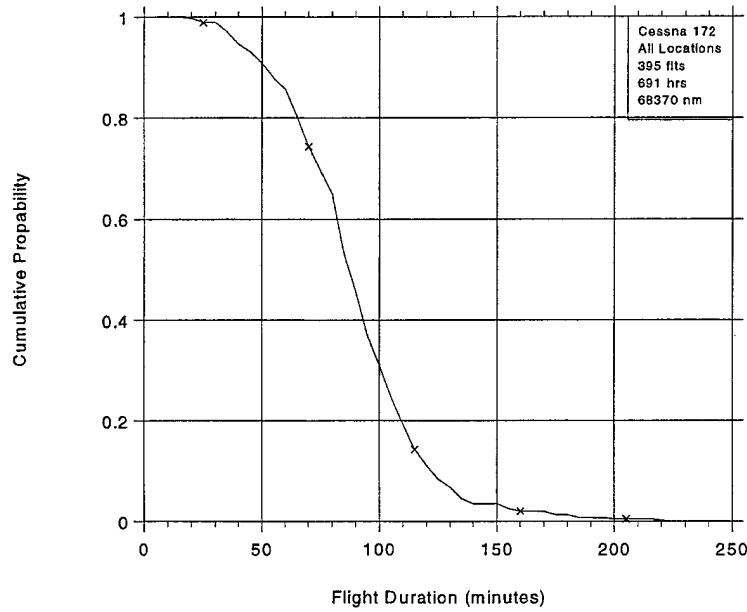

FIGURE A-10. CUMULATIVE PROBABILITY OF FLIGHT DURATION

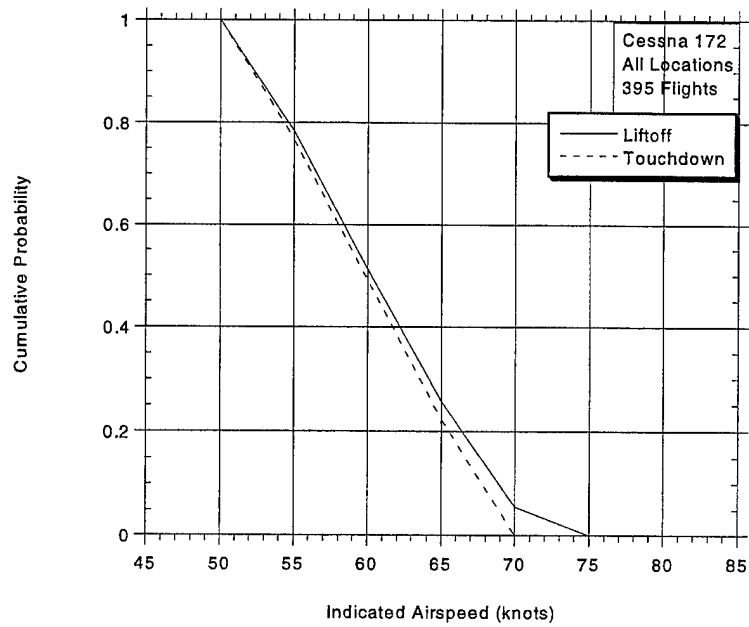

FIGURE A-11. CUMULATIVE PROBABILITY OF AIRSPEED AT LIFTOFF AND TOUCHDOWN

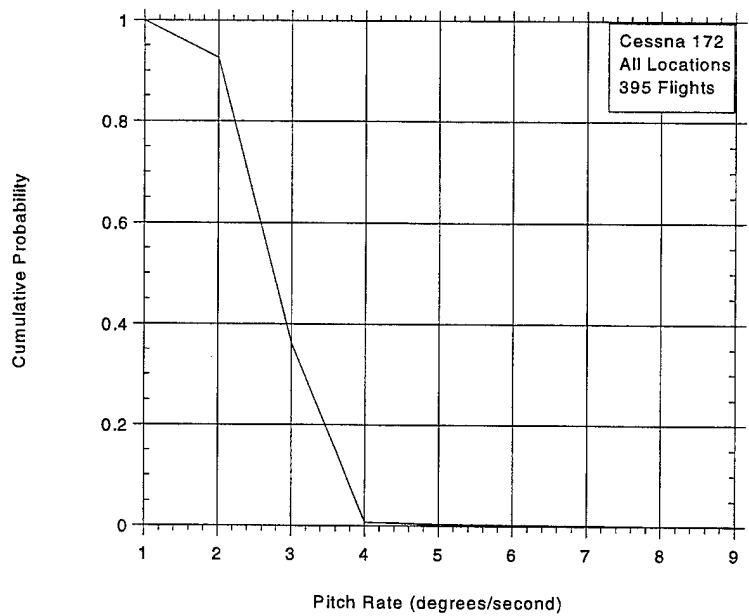

FIGURE A-12. CUMULATIVE PROBABILITY OF PITCH RATE AT LIFTOFF

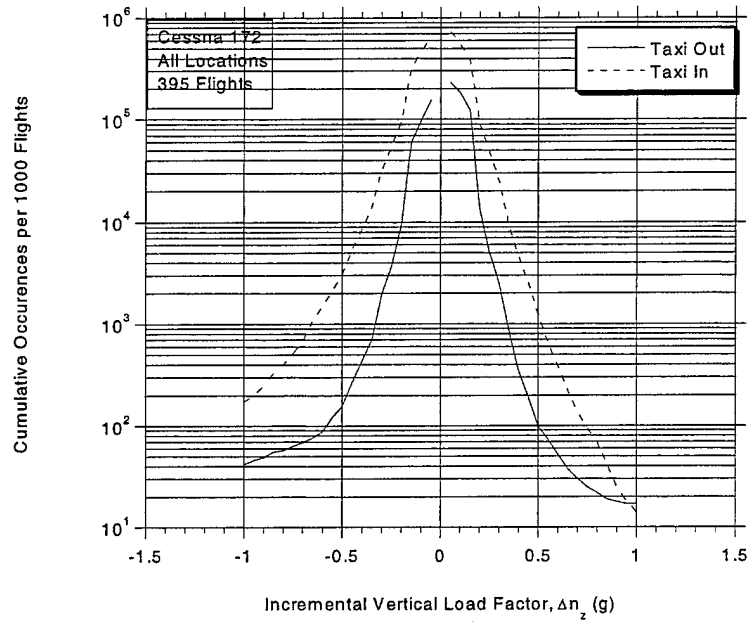

FIGURE A-13. CUMULATIVE FREQUENCY OF INCREMENTAL VERTICAL LOAD FACTOR DURING TAXI OPERATIONS

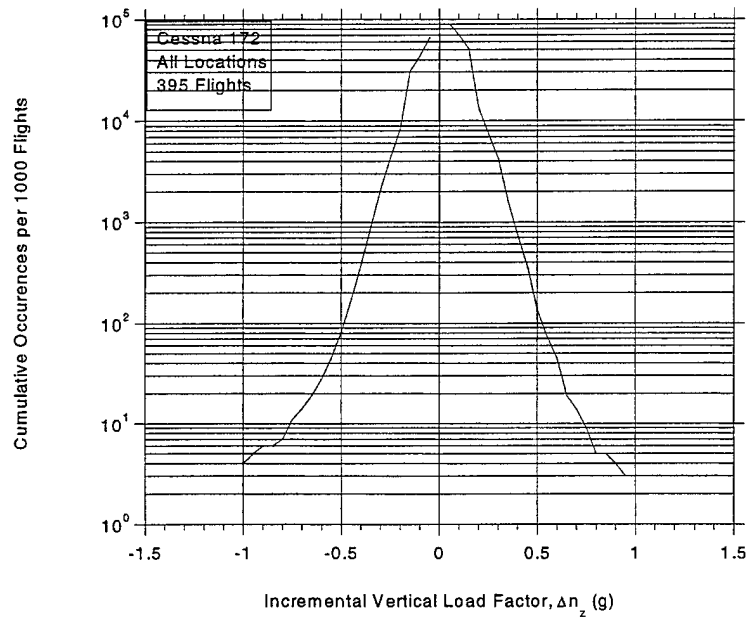

FIGURE A-14. CUMULATIVE OCCURRENCES OF INCREMENTAL VERTICAL LOAD FACTOR DURING TAKEOFF ROLL

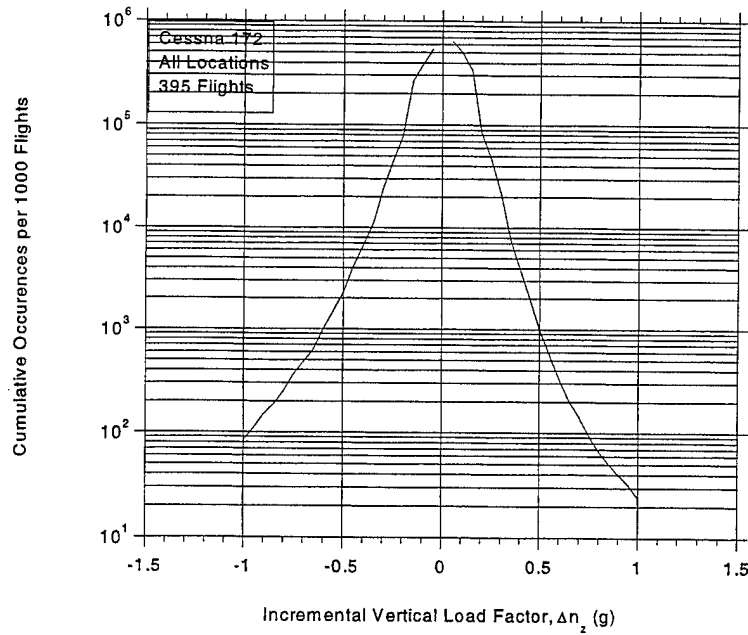

FIGURE A-15. CUMULATIVE OCCURRENCES OF INCREMENTAL VERTICAL LOAD FACTOR DURING LANDING ROLL

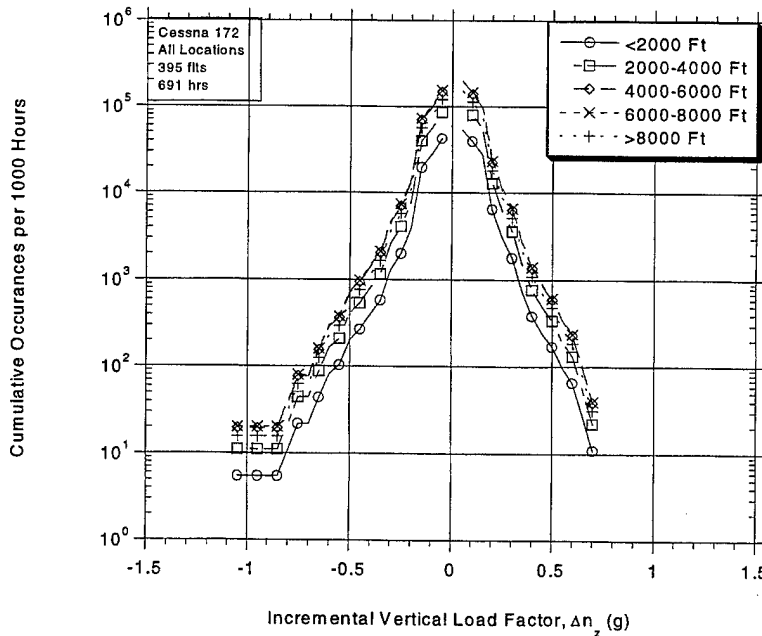

FIGURE A-16. CUMULATIVE OCCURRENCES OF INCREMENTAL GUST LOAD FACTOR PER 1000 HOURS BY PRESSURE ALTITUDE FOR COMBINED CLIMB, CRUISE, AND DESCENT PHASES

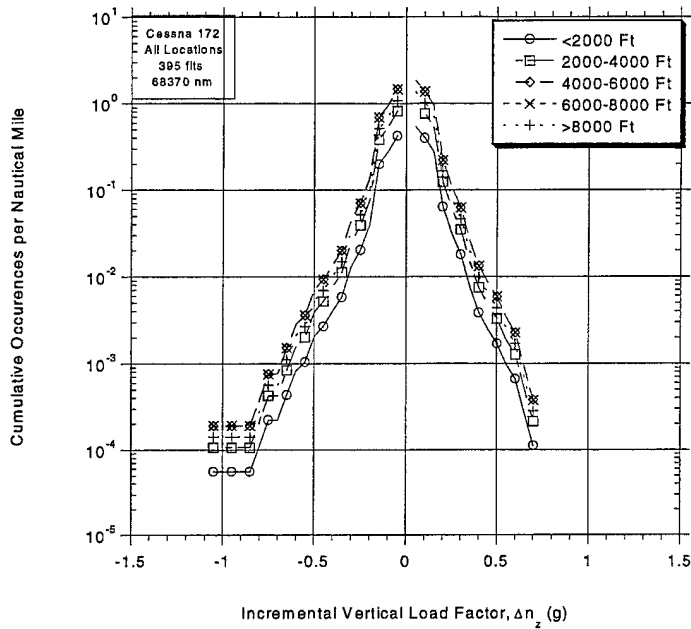

FIGURE A-17. CUMULATIVE OCCURRENCES OF INCREMENTAL GUST LOAD FACTOR PER NAUTICAL MILE BY PRESSURE ALTITUDE FOR COMBINED CLIMB, CRUISE, AND DESCENT PHASES

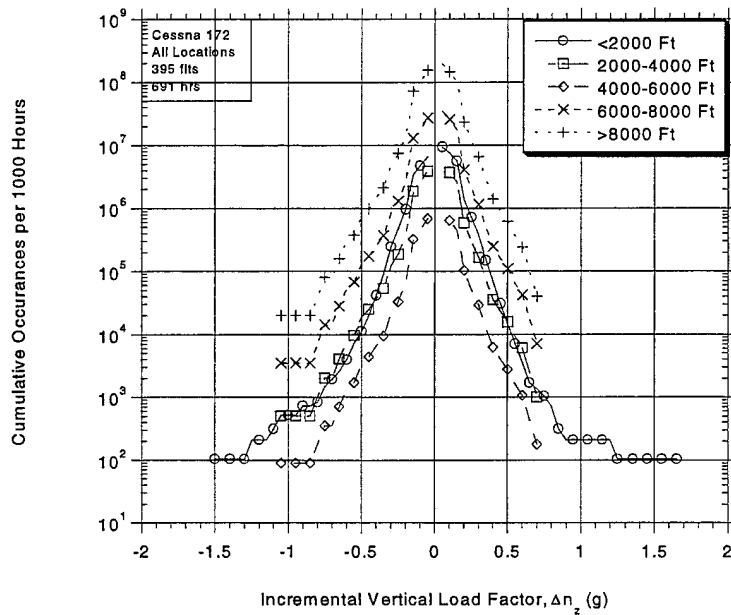

FIGURE A-18. CUMULATIVE OCCURRENCES OF INCREMENTAL GUST LOAD FACTOR PER 1000 HOURS BY ALTITUDE ABOVE AIRPORT FOR DEPARTURE PHASE

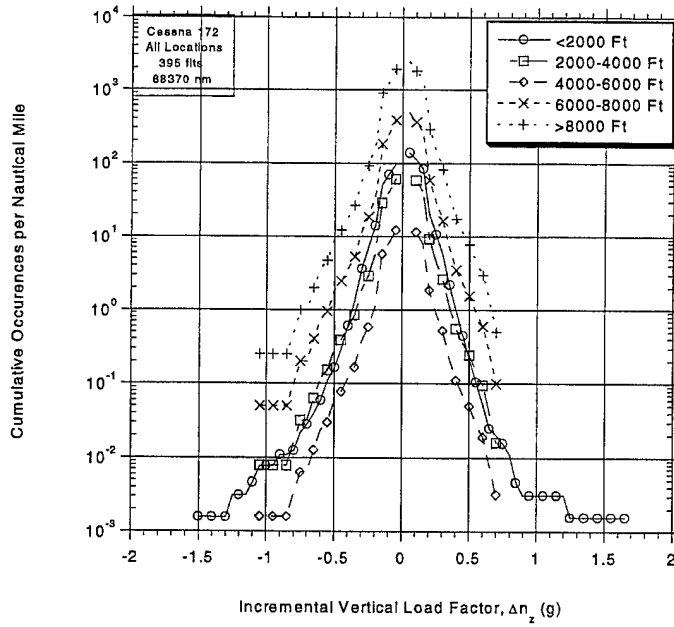

FIGURE A-19. CUMULATIVE OCCURRENCES OF INCREMENTAL GUST LOAD FACTOR PER NAUTICAL MILE BY ALTITUDE ABOVE AIRPORT FOR DEPARTURE PHASE

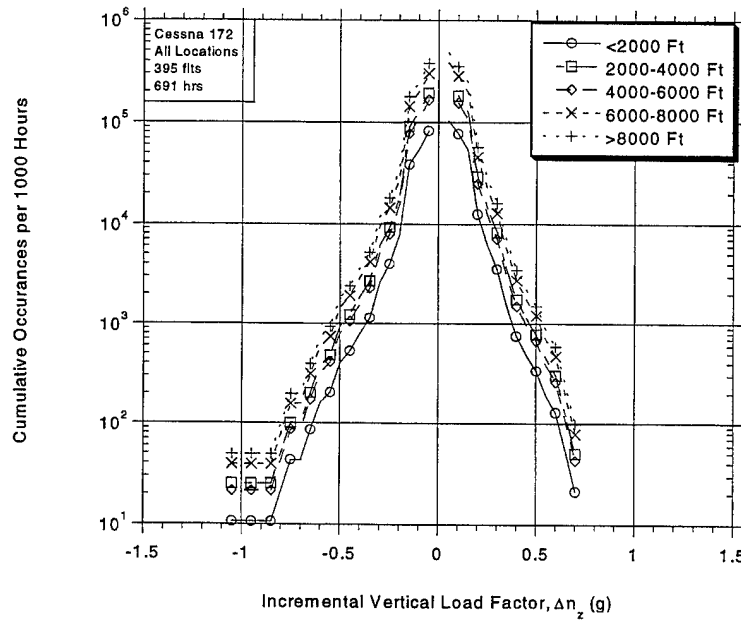

FIGURE A-20. CUMULATIVE OCCURRENCES OF INCREMENTAL GUST LOAD FACTOR PER 1000 HOURS BY ALTITUDE ABOVE AIRPORT FOR APPROACH PHASE

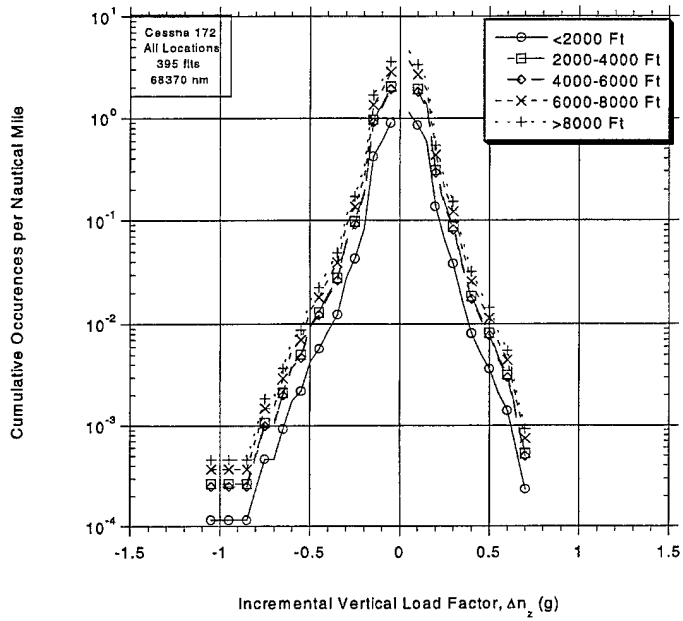

FIGURE A-21. CUMULATIVE OCCURRENCES OF INCREMENTAL GUST LOAD FACTOR PER NAUTICAL MILE BY ALTITUDE ABOVE AIRPORT FOR APPROACH PHASE

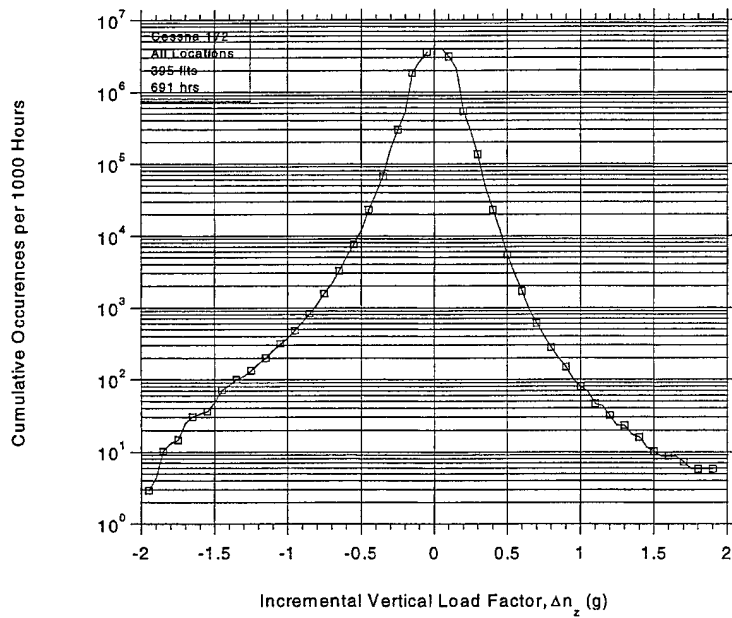

FIGURE A-22. CUMULATIVE OCCURRENCES OF INCREMENTAL GUST LOAD FACTOR PER 1000 HOURS, COMBINED FLIGHT PHASES

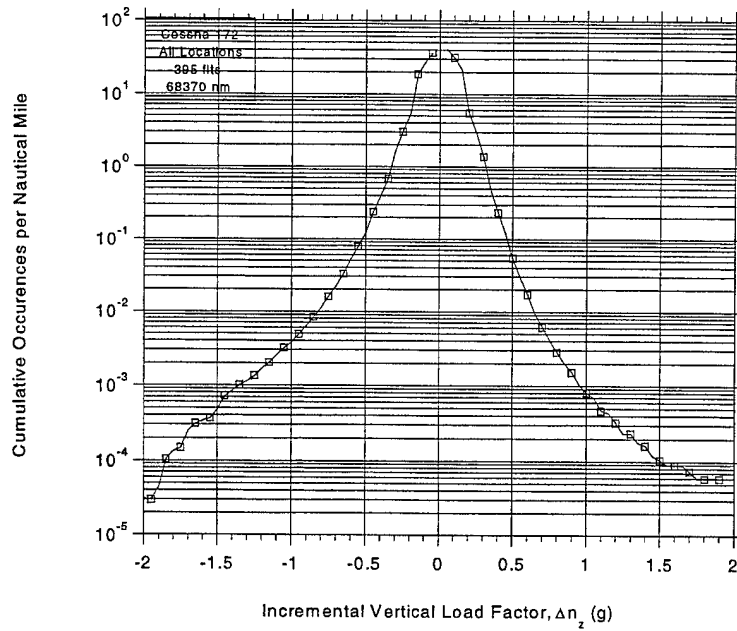

FIGURE A-23. CUMULATIVE OCCURRENCES OF INCREMENTAL GUST LOAD FACTOR PER NAUTICAL MILE

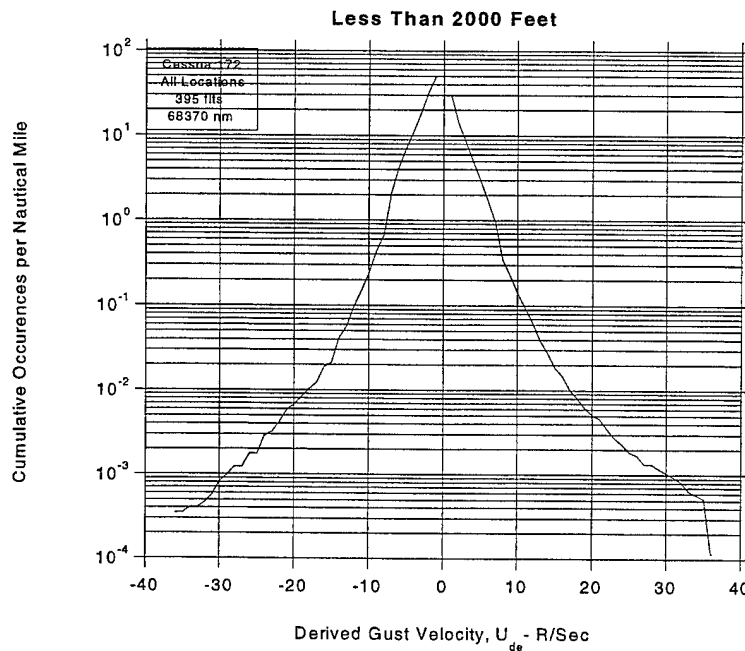

FIGURE A-24. CUMULATIVE OCCURRENCES OF DERIVED GUST VELOCITY PER NAUTICAL MILE FOR < 2000 feet

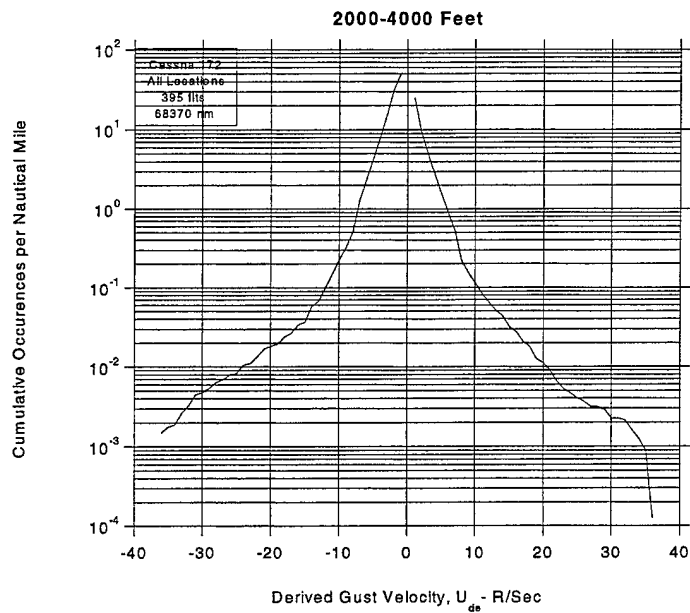

FIGURE A-25. CUMULATIVE OCCURRENCES OF DERIVED GUST VELOCITY PER NAUTICAL MILE FOR 2000-4000 feet

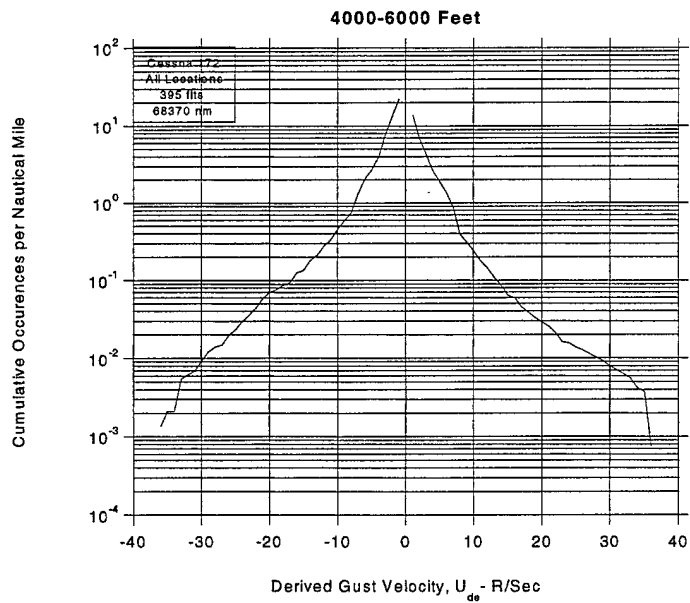

FIGURE A-26. CUMULATIVE OCCURRENCES OF DERIVED GUST VELOCITY PER NAUTICAL MILE FOR 4000-6000 feet

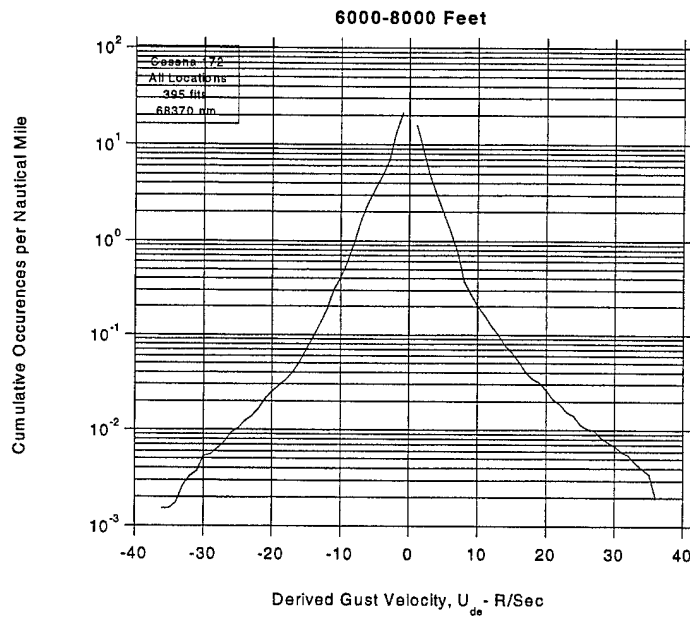

FIGURE A-27. CUMULATIVE OCCURRENCES OF DERIVED GUST VELOCITY PER NAUTICAL MILE FOR 6000-8000 feet

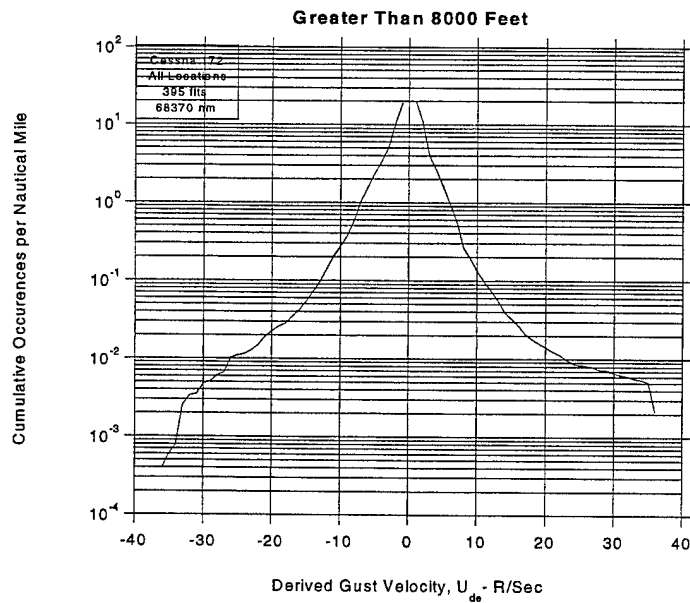

FIGURE A-28. CUMULATIVE OCCURRENCES OF DERIVED GUST VELOCITY PER NAUTICAL MILE FOR > 8000 feet

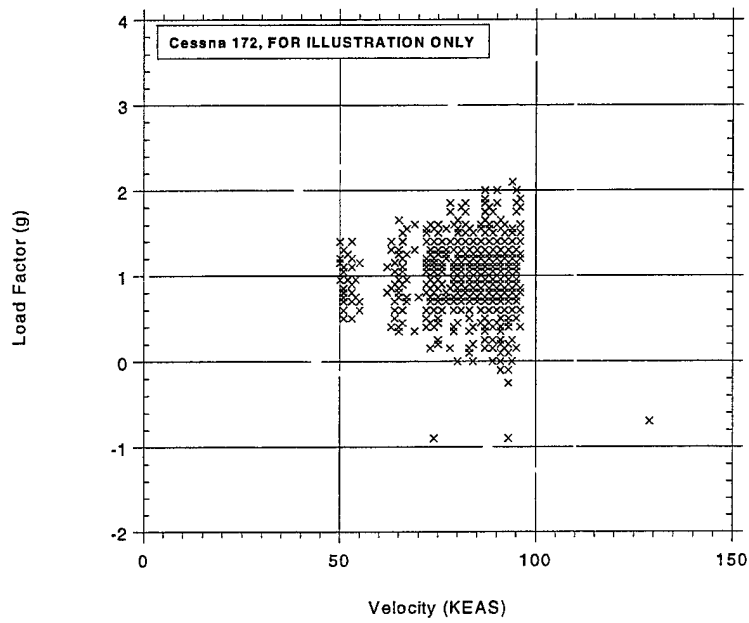

FIGURE A-29. COINCIDENT GUST LOAD FACTOR AND SPEED DURING DEPARTURE

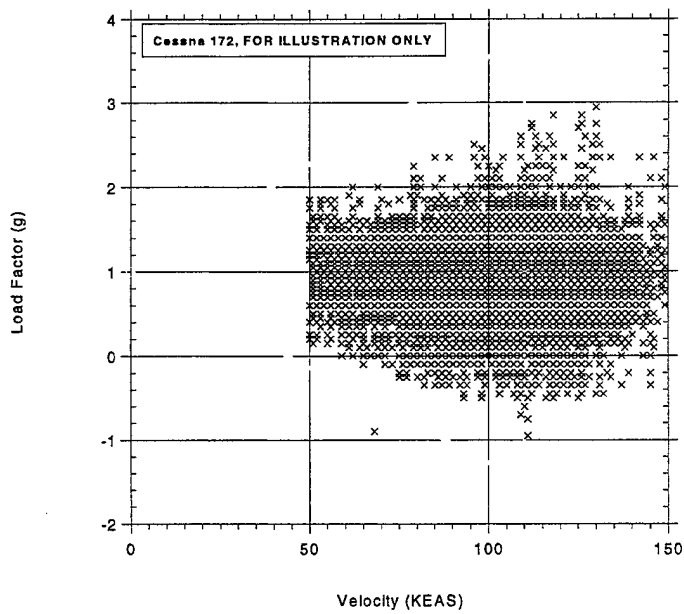

FIGURE A-30. COINCIDENT GUST LOAD FACTOR AND SPEED DURING APPROACH

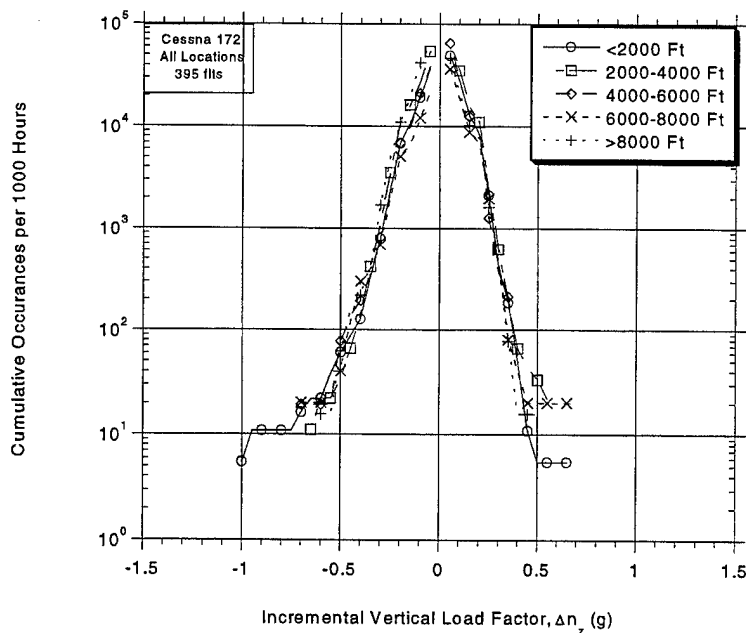

FIGURE A-31. CUMULATIVE OCCURRENCES OF INCREMENTAL MANEUVER LOAD FACTOR PER 1000 HOURS BY PRESSURE ALTITUDE FOR COMBINED CLIMB, CRUISE, AND DESCENT PHASES

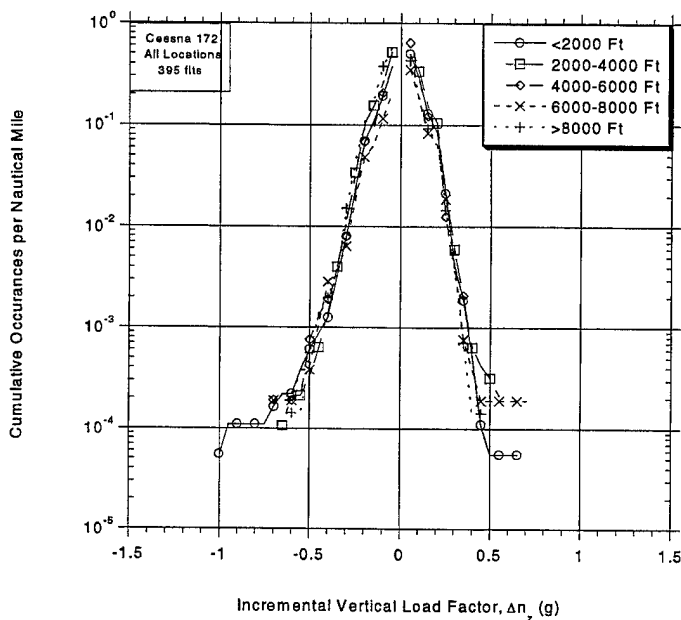

FIGURE A-32. CUMULATIVE OCCURRENCES OF INCREMENTAL MANEUVER LOAD FACTOR PER NAUTICAL MILE BY PRESSURE ALTITUDE FOR COMBINED CLIMB, CRUISE, AND DESCENT PHASES

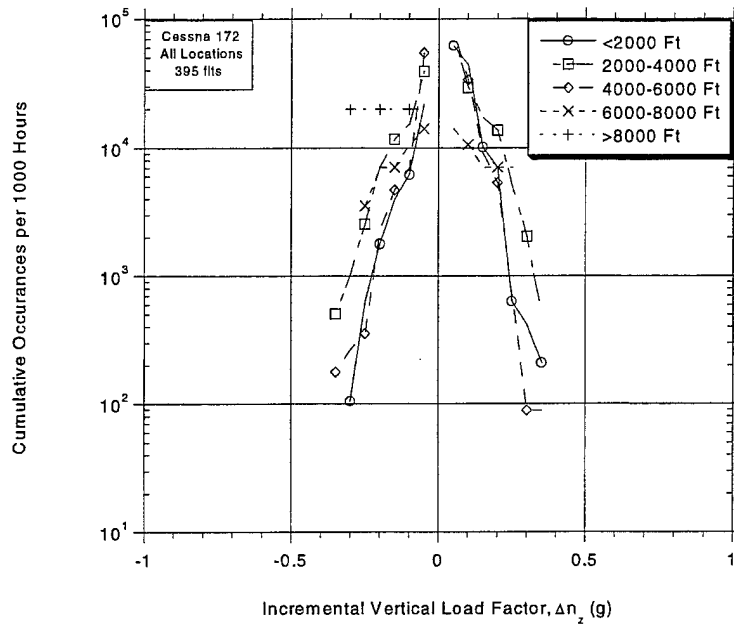

FIGURE A-33. CUMULATIVE OCCURRENCES OF INCREMENTAL MANEUVER LOAD FACTOR PER 1000 HOURS BY ALTITUDE ABOVE AIRPORT FOR DEPARTURE PHASE

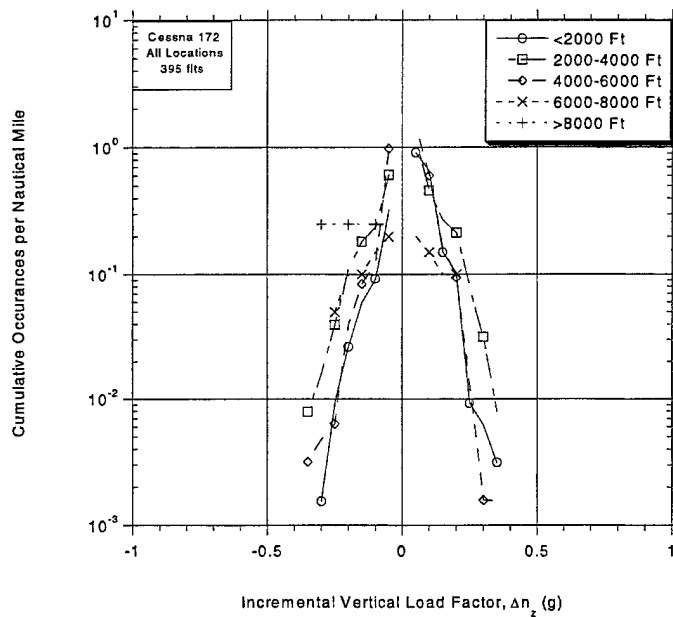

FIGURE A-34. CUMULATIVE OCCURRENCES OF INCREMENTAL MANEUVER LOAD FACTOR PER NAUTICAL MILE BY ALTITUDE ABOVE AIRPORT FOR DEPARTURE PHASE

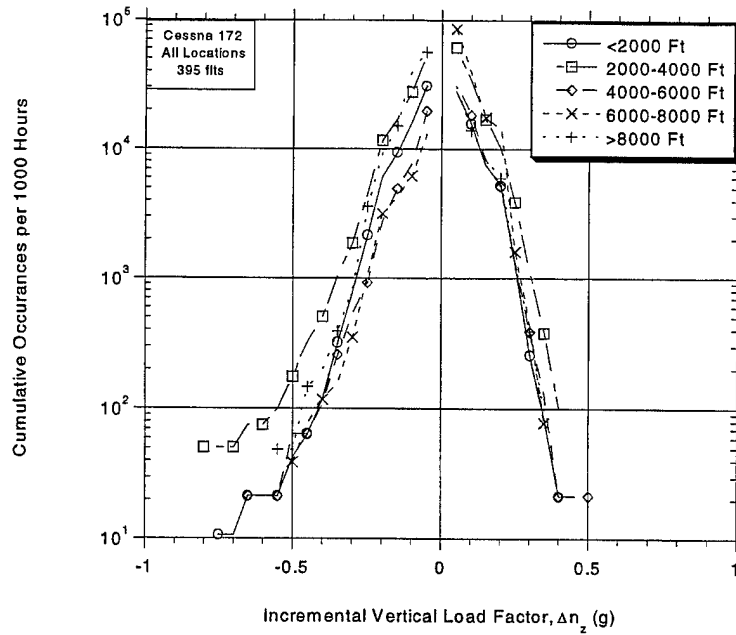

FIGURE A-35. CUMULATIVE OCCURRENCES OF INCREMENTAL MANEUVER LOAD FACTOR PER 1000 HOURS BY ALTITUDE ABOVE AIRPORT FOR APPROACH PHASE

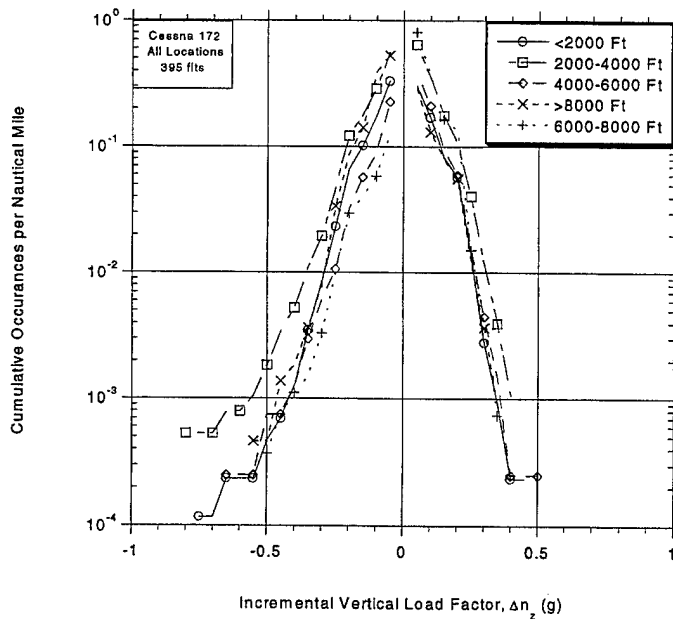

FIGURE A-36. CUMULATIVE OCCURRENCES OF INCREMENTAL MANEUVER LOAD FACTOR PER NAUTICAL MILE BY ALTITUDE ABOVE AIRPORT FOR APPROACH PHASE

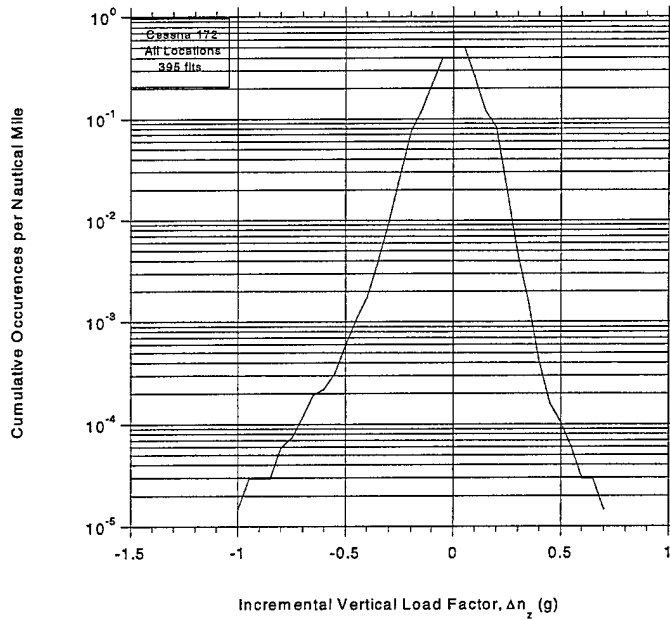

FIGURE A-37. CUMULATIVE OCCURRENCES OF INCREMENTAL MANEUVER LOAD FACTOR PER NAUTICAL MILE

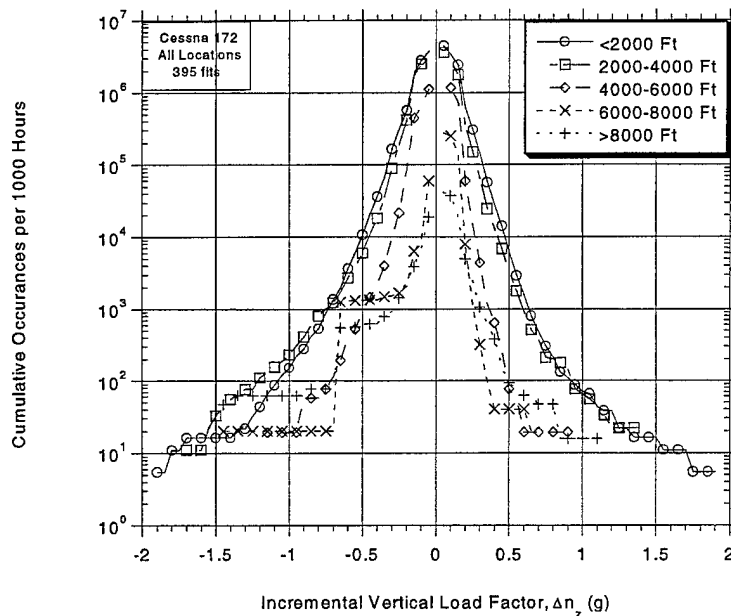

FIGURE A-38. CUMULATIVE OCCURRENCES OF INCREMENTAL LOAD FACTOR PER 1000 HOURS BY PRESSURE ALTITUDE FOR COMBINED CLIMB, CRUISE, AND DESCENT PHASES

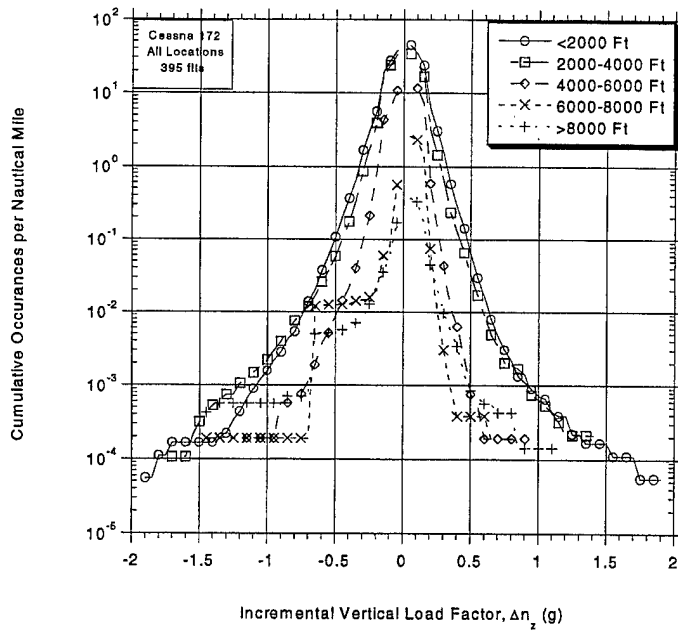

FIGURE A-39. CUMULATIVE OCCURRENCES OF INCREMENTAL LOAD FACTOR PER NAUTICAL MILE BY PRESSURE ALTITUDE FOR COMBINED CLIMB, CRUISE, AND DESCENT PHASES

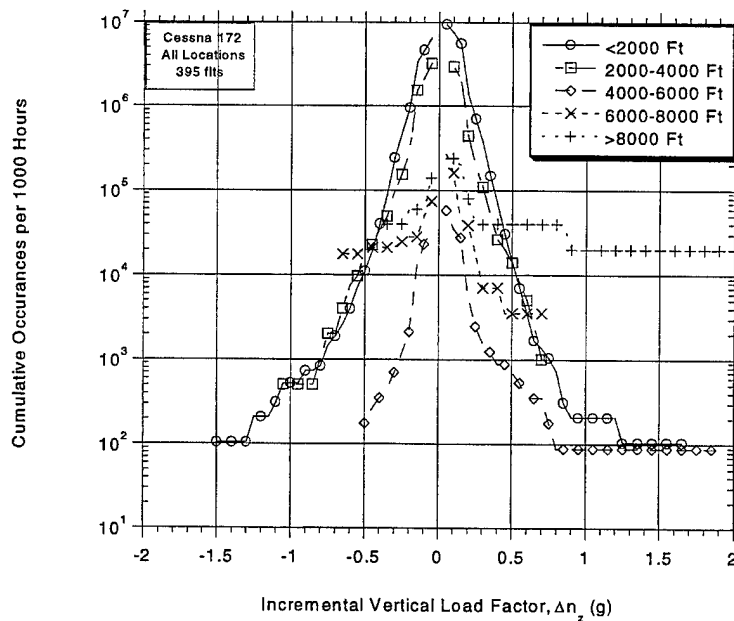

FIGURE A-40. CUMULATIVE OCCURRENCES OF INCREMENTAL LOAD FACTOR PER 1000 HOURS BY ALTITUDE ABOVE AIRPORT FOR DEPARTURE PHASE

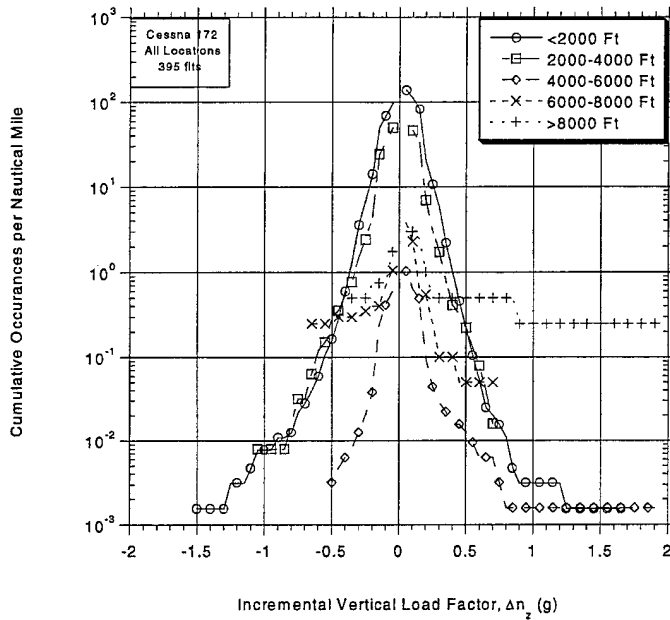

FIGURE A-41. CUMULATIVE OCCURRENCES OF INCREMENTAL LOAD FACTOR PER NAUTICAL MILE BY ALTITUDE ABOVE AIRPORT FOR DEPARTURE PHASE

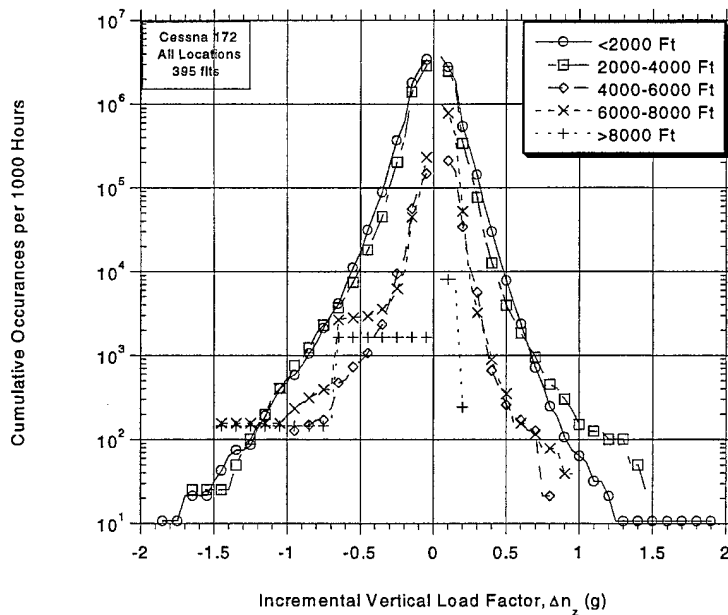

FIGURE A-42. CUMULATIVE OCCURRENCES OF INCREMENTAL LOAD FACTOR PER 1000 HOURS BY ALTITUDE ABOVE AIRPORT FOR APPROACH PHASE

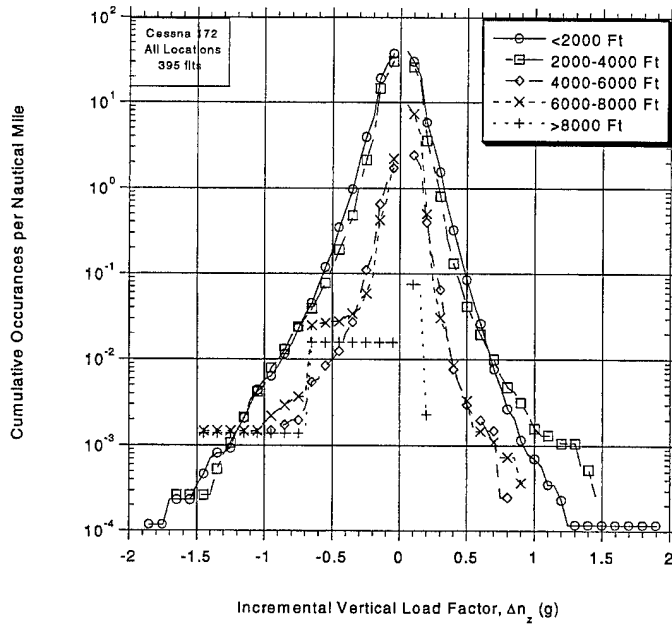

FIGURE A-43. CUMULATIVE OCCURRENCES OF INCREMENTAL LOAD FACTOR PER NAUTICAL MILE BY ALTITUDE ABOVE AIRPORT FOR APPROACH PHASE

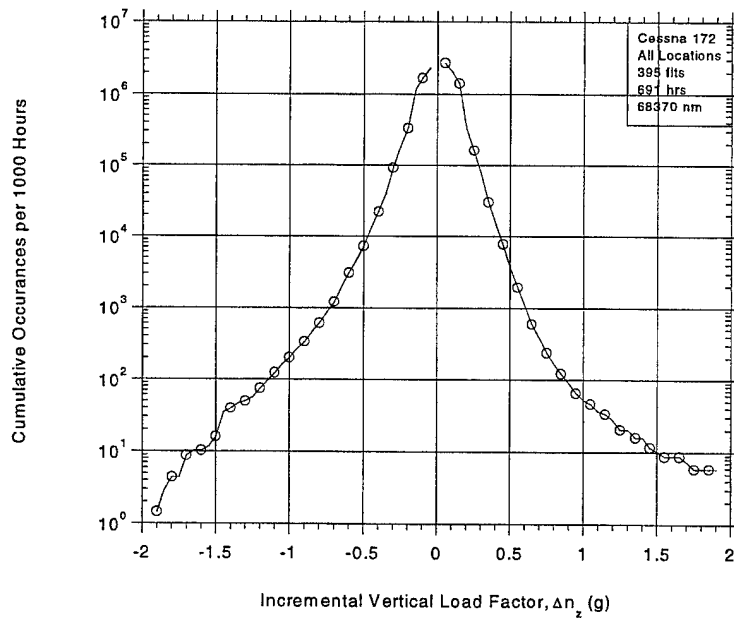

FIGURE A-44. CUMULATIVE OCCURRENCES OF INCREMENTAL LOAD FACTOR PER 1000 HOURS FOR COMBINED FLIGHT PHASES

APPENDIX B—STATISTICAL FORMATS, AIRCRAFT USAGE DATA,
DAYTONA AIRCRAFT

		Maximum Altitude (1000 feet)			Total
		0-5	5-10	10-15	
Flight Distance (nm)	0-50	60%	2%	0%	62%
	50-100	27%	2%	0%	29%
	100-150	7%	1%	0%	8%
	150-200	1%	1%	0%	1%
	200-250	0%	0%	0%	0%
	250-300	0%	0%	0%	0%
	300-350	0%	0%	0%	0%
	350-400	0%	0%	0%	0%
	400-450	0%	0%	0%	0%
	Total	94%	6%	0%	100%

FIGURE B-1. CORRELATION OF MAXIMUM ALTITUDE AND FLIGHT DISTANCE, PERCENT OF FLIGHTS

		Total Flight Distance (nm)								
		0-50	50-100	100-150	150-200	200-250	250-300	300-350	350-400	400-450
Altitude Band (feet)	0-5k	97%	93%	86%	50%	0%	0%	0%	0%	0%
	5k-10k	3%	7%	14%	50%	0%	0%	0%	0%	0%
	10k-15k	0%	0%	0%	0%	0%	0%	0%	0%	0%
	Total	100%	100%	100%	100%	0%	0%	0%	0%	0%
	Number of Flights	283	134	35	6	0	0	0	0	0

FIGURE B-2. PERCENT OF TOTAL DISTANCE IN ALTITUDE BANDS

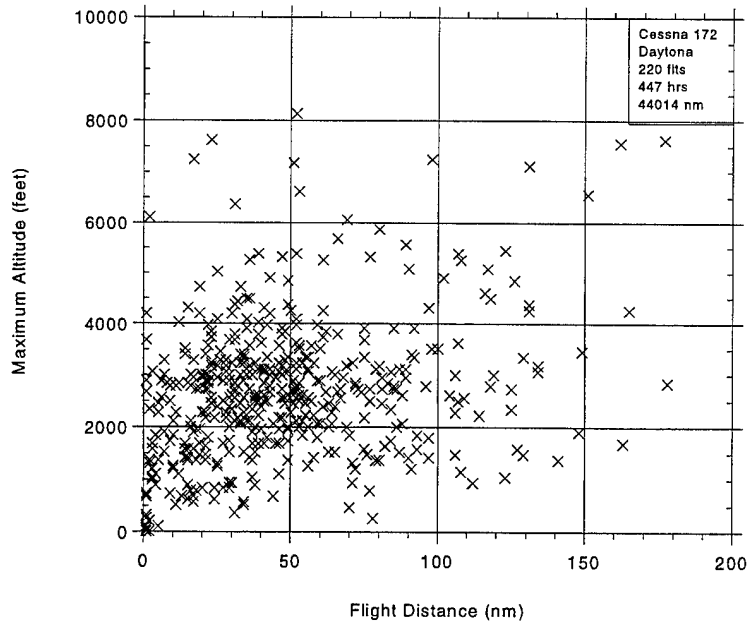

FIGURE B-3. COINCIDENT FLIGHT DISTANCE AND MAXIMUM FLIGHT ALTITUDE

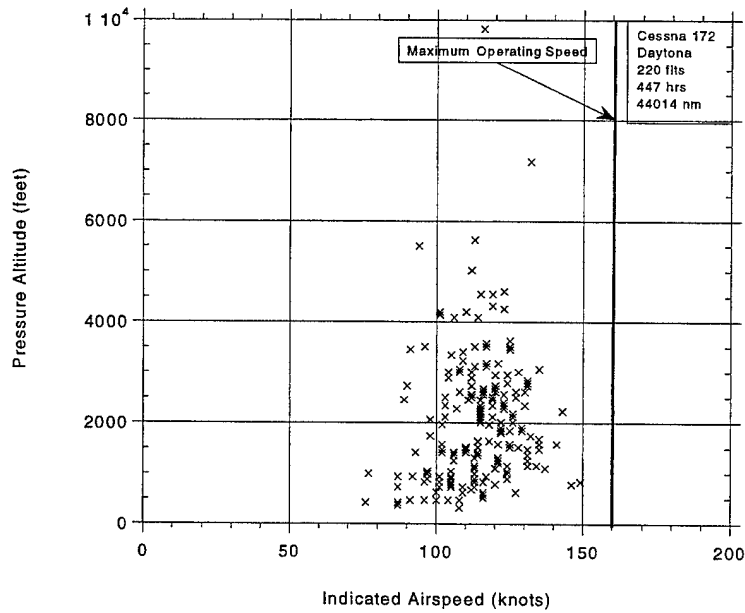

FIGURE B-4. COINCIDENT ALTITUDE AT MAXIMUM INDICATED AIRSPEED, ALL FLIGHT PHASES

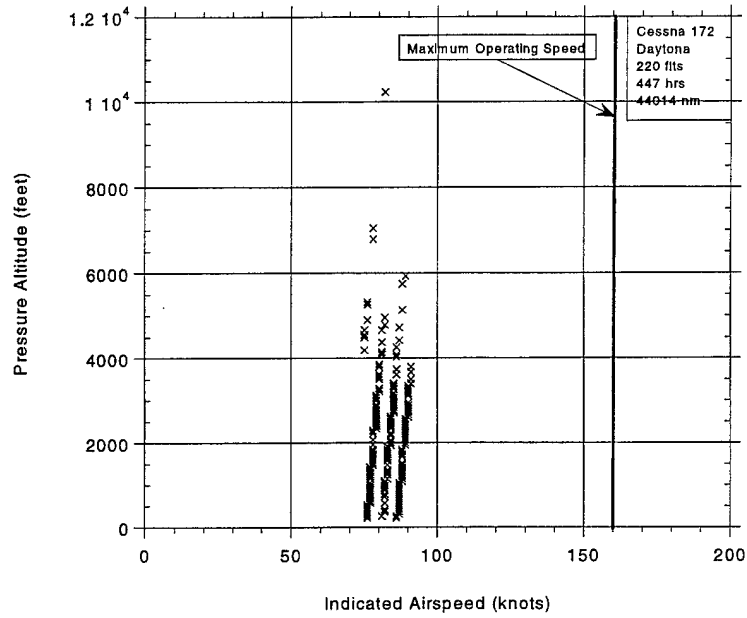

FIGURE B-5. MAXIMUM SPEED AND COINCIDENT ALTITUDE DURING CLIMB

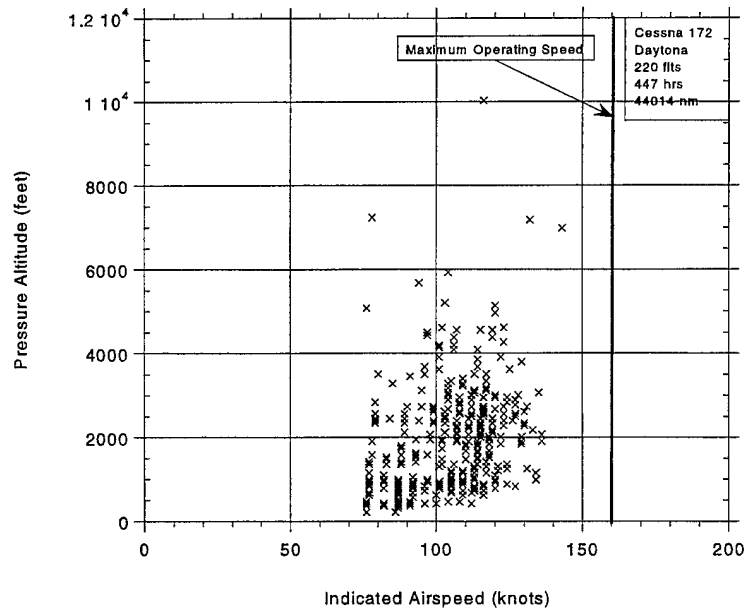

FIGURE B-6. MAXIMUM SPEED AND COINCIDENT ALTITUDE DURING CRUISE

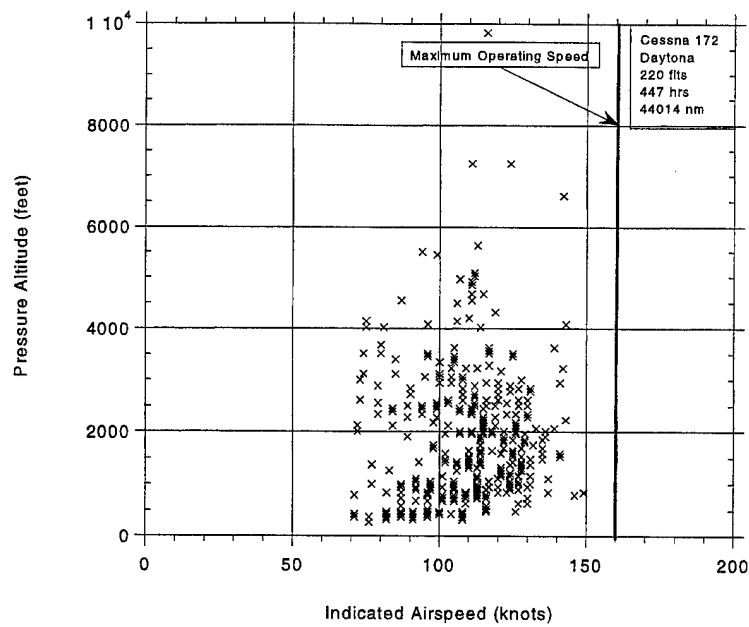

FIGURE B-7. MAXIMUM SPEED AND COINCIDENT ALTITUDE DURING DESCENT

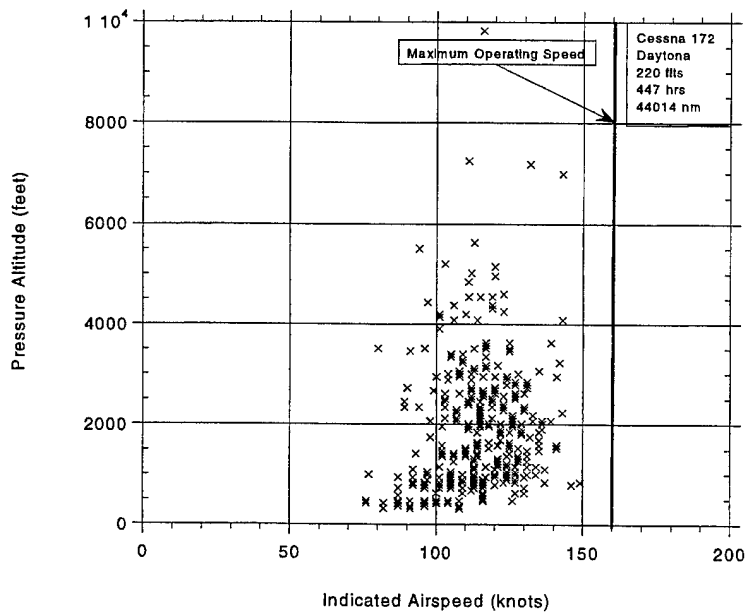

FIGURE B-8. MAXIMUM SPEED AND COINCIDENT ALTITUDE DURING ALL FLIGHT PHASES

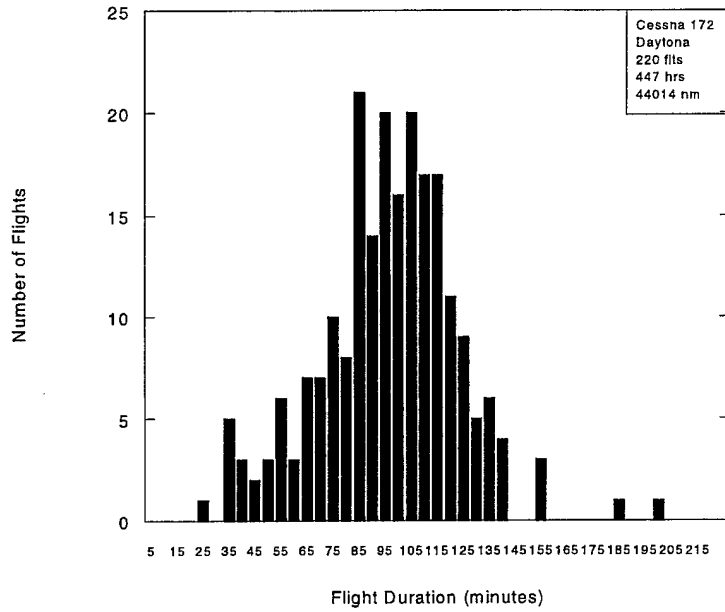

FIGURE B-9. NUMBER OF FLIGHTS VS FLIGHT DURATION

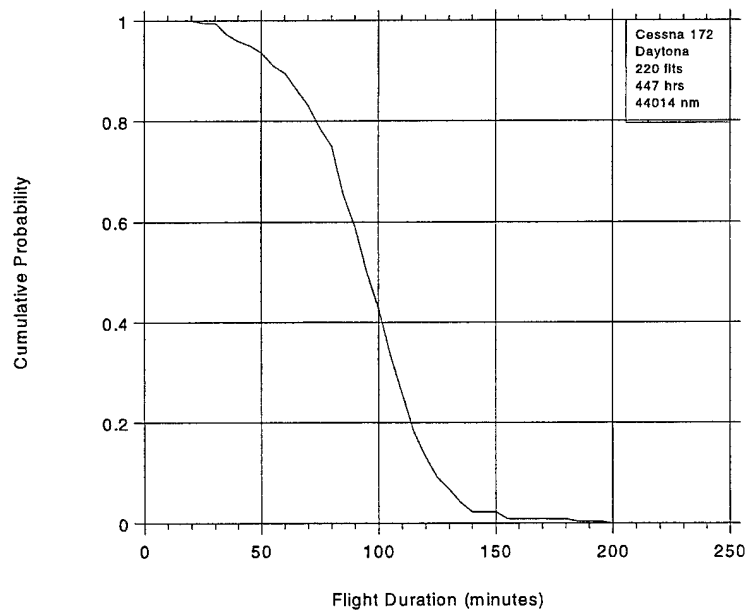

FIGURE B-10. CUMULATIVE PROBABILITY OF FLIGHT DURATION

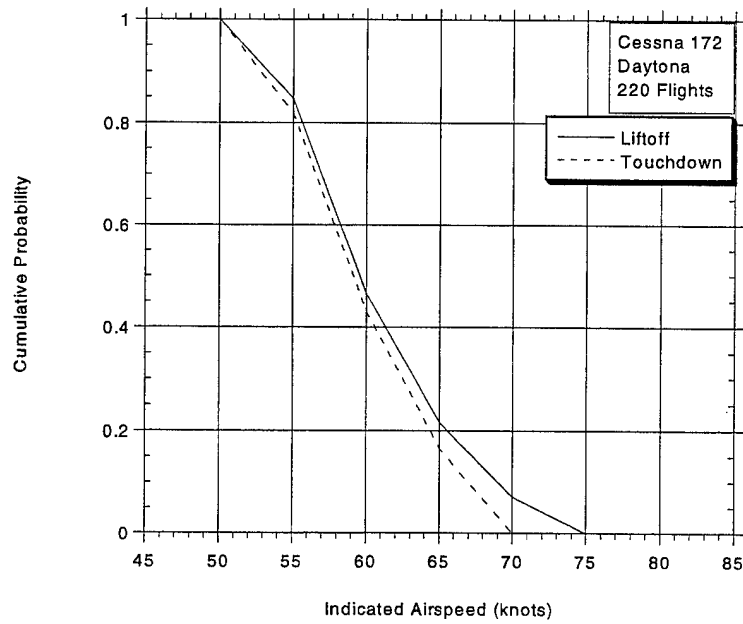

FIGURE B-11. CUMULATIVE PROBABILITY OF AIRSPEED AT LIFTOFF AND TOUCHDOWN

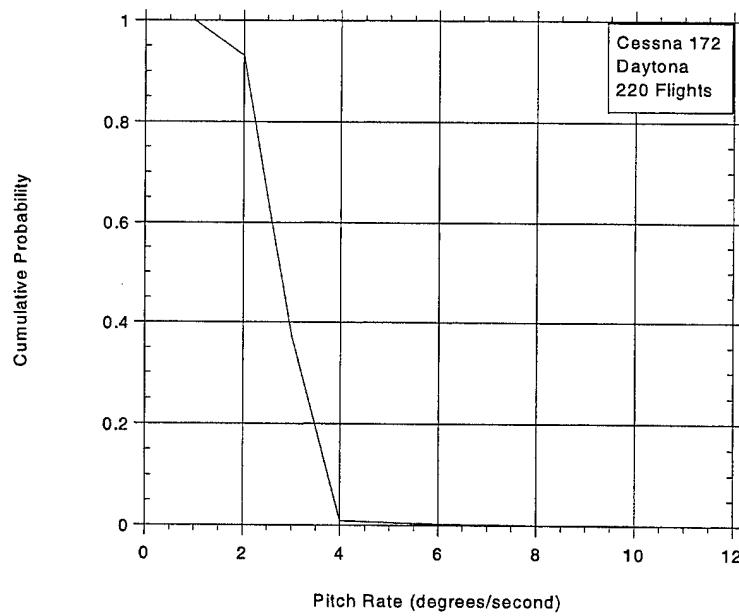

FIGURE B-12. CUMULATIVE PROBABILITY OF PITCH RATE AT LIFTOFF

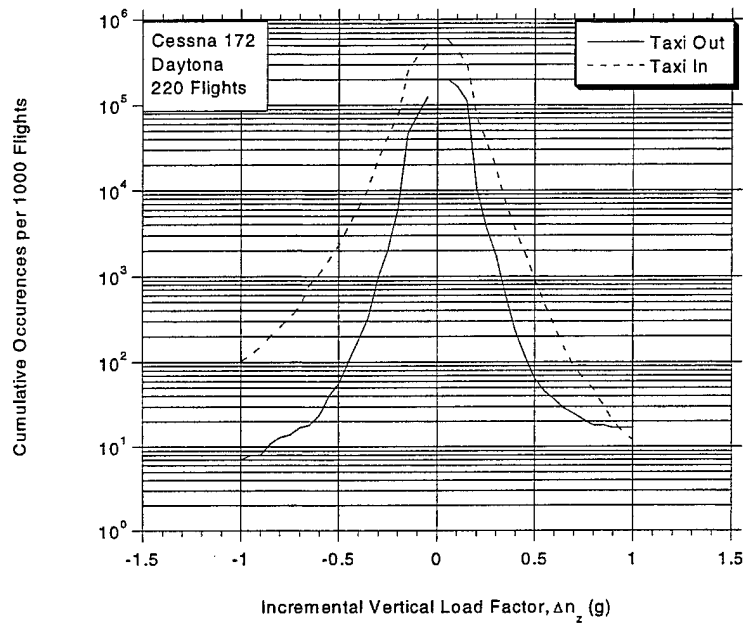

FIGURE B-13. CUMULATIVE FREQUENCY OF INCREMENTAL VERTICAL LOAD FACTOR DURING TAXI OPERATIONS

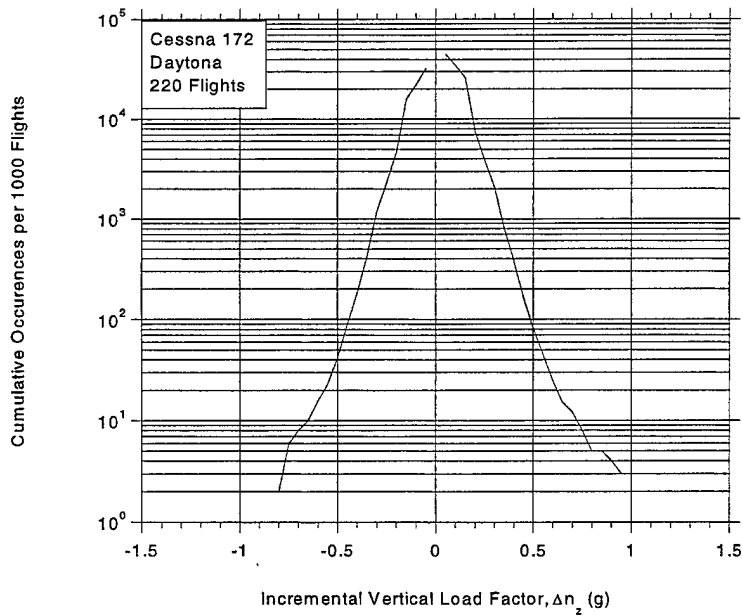

FIGURE B-14. CUMULATIVE OCCURRENCES OF INCREMENTAL VERTICAL LOAD FACTOR DURING TAKEOFF ROLL

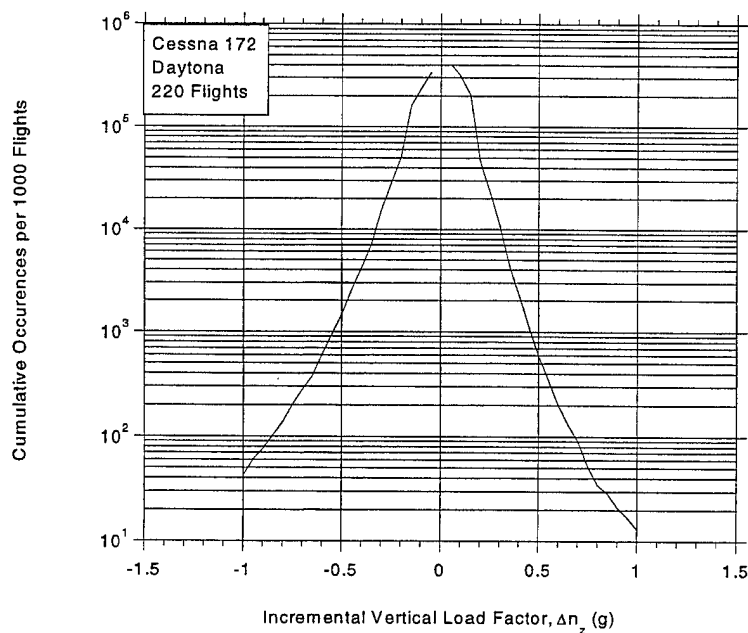

FIGURE B-15. CUMULATIVE OCCURRENCES OF INCREMENTAL VERTICAL LOAD FACTOR DURING LANDING ROLL

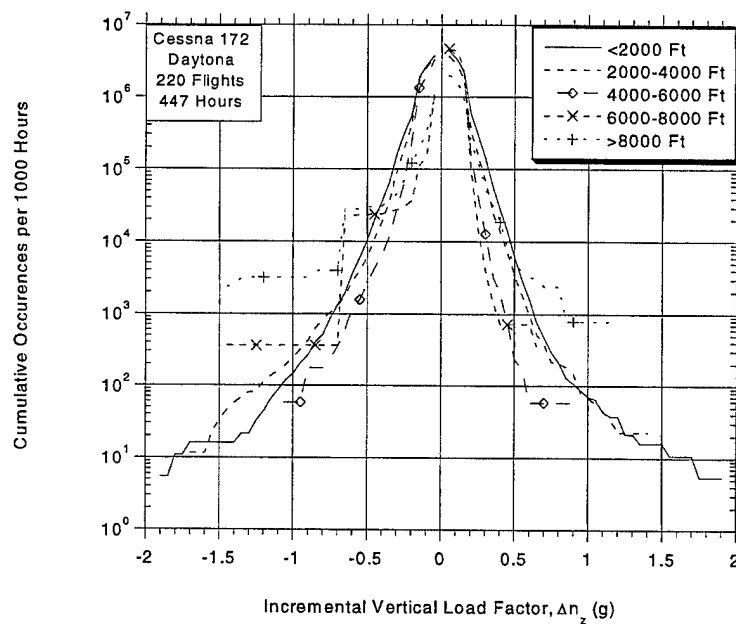

FIGURE B-16. CUMULATIVE OCCURRENCES OF INCREMENTAL GUST LOAD FACTOR PER 1000 HOURS BY PRESSURE ALTITUDE FOR COMBINED CLIMB, CRUISE, AND DESCENT PHASES

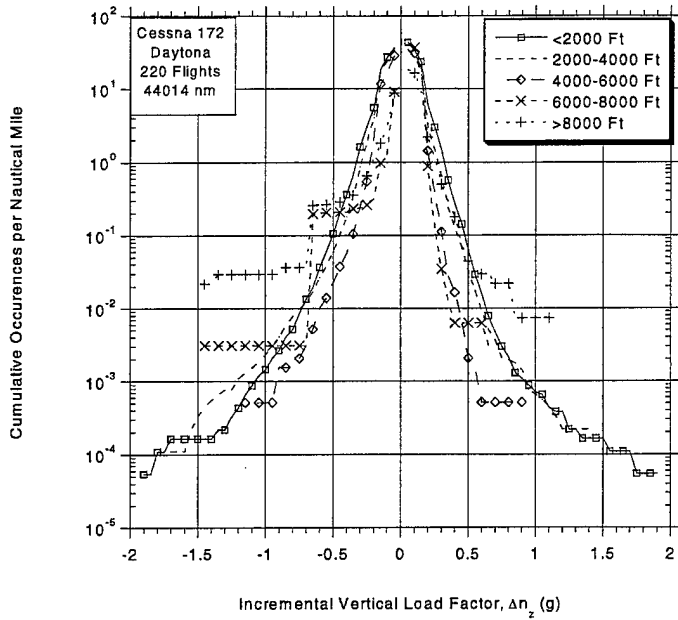

FIGURE B-17. CUMULATIVE OCCURRENCES OF INCREMENTAL GUST LOAD FACTOR PER NAUTICAL MILE BY PRESSURE ALTITUDE FOR COMBINED CLIMB, CRUISE, AND DESCENT PHASES

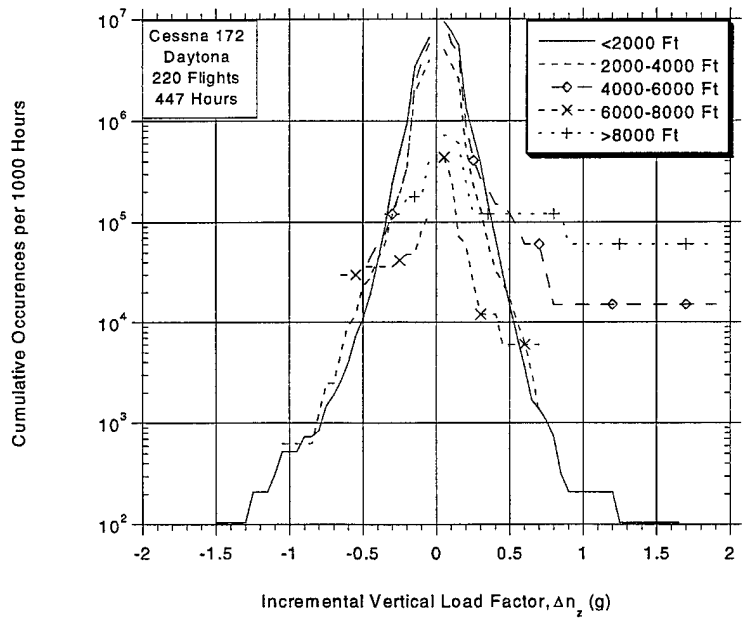

FIGURE B-18. CUMULATIVE OCCURRENCES OF INCREMENTAL GUST LOAD FACTOR PER 1000 HOURS BY ALTITUDE ABOVE AIRPORT FOR DEPARTURE PHASE

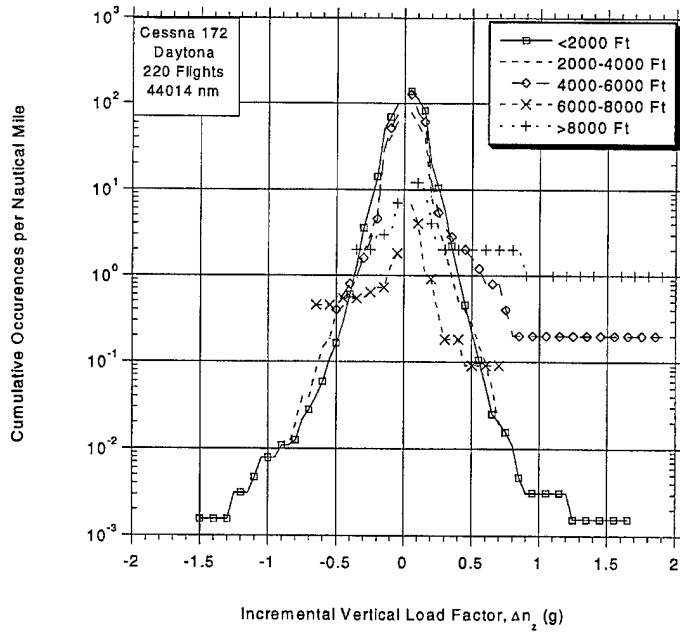

FIGURE B-19. CUMULATIVE OCCURRENCES OF INCREMENTAL GUST LOAD FACTOR PER NAUTICAL MILE BY ALTITUDE ABOVE AIRPORT FOR DEPARTURE PHASE

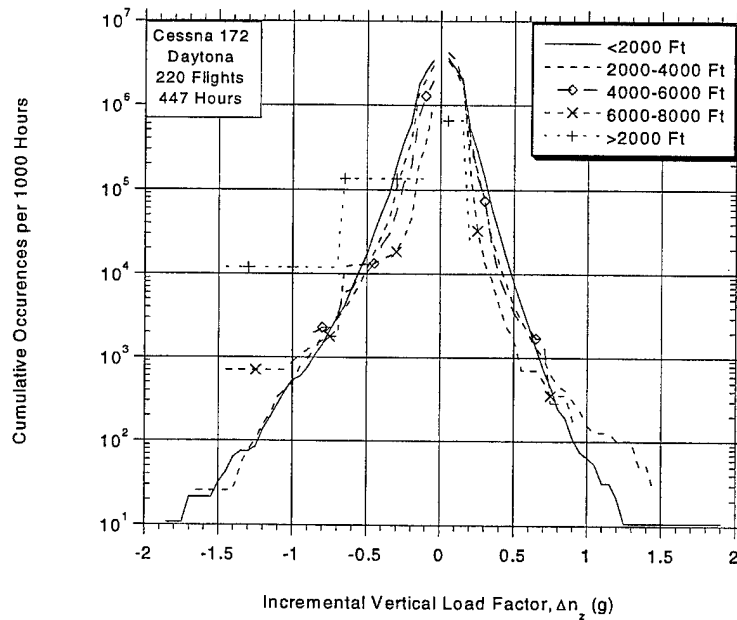

FIGURE B-20. CUMULATIVE OCCURRENCES OF INCREMENTAL GUST LOAD FACTOR PER 1000 HOURS BY ALTITUDE ABOVE AIRPORT FOR APPROACH PHASE

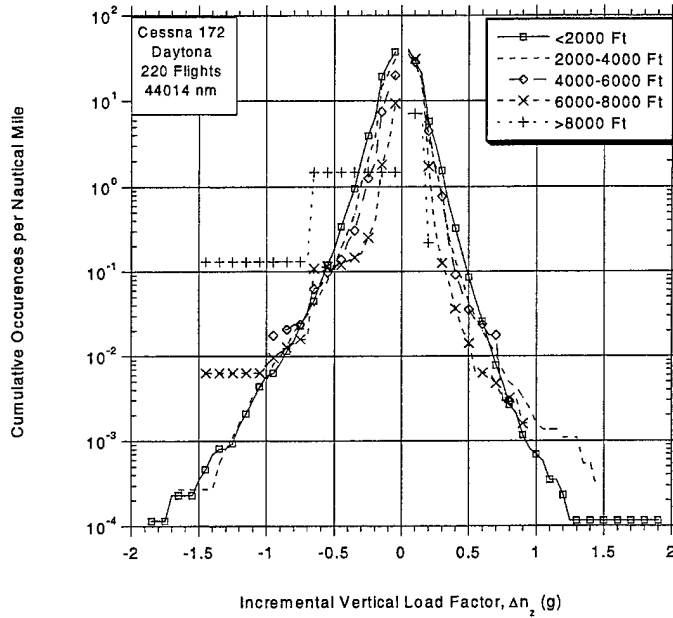

FIGURE B-21. CUMULATIVE OCCURRENCES OF INCREMENTAL GUST LOAD FACTOR PER NAUTICAL MILE BY ALTITUDE ABOVE AIRPORT FOR APPROACH PHASE

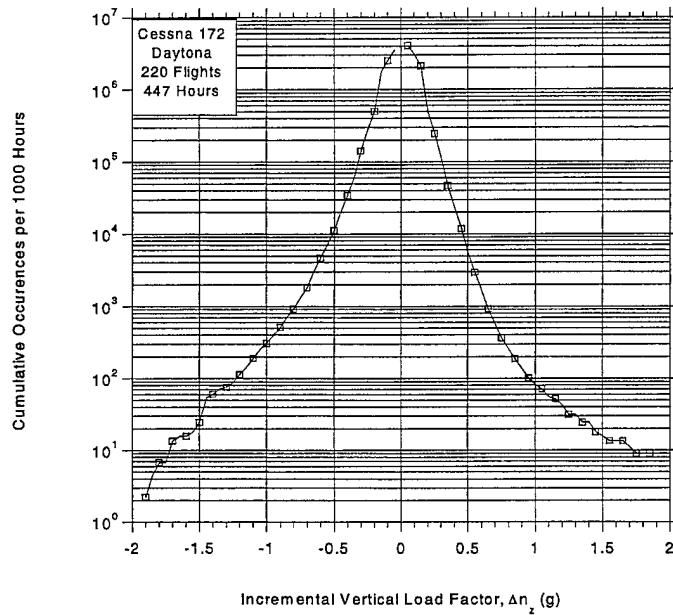

FIGURE B-22. CUMULATIVE OCCURRENCES OF INCREMENTAL GUST LOAD FACTOR PER 1000 HOURS, COMBINED FLIGHT PHASES

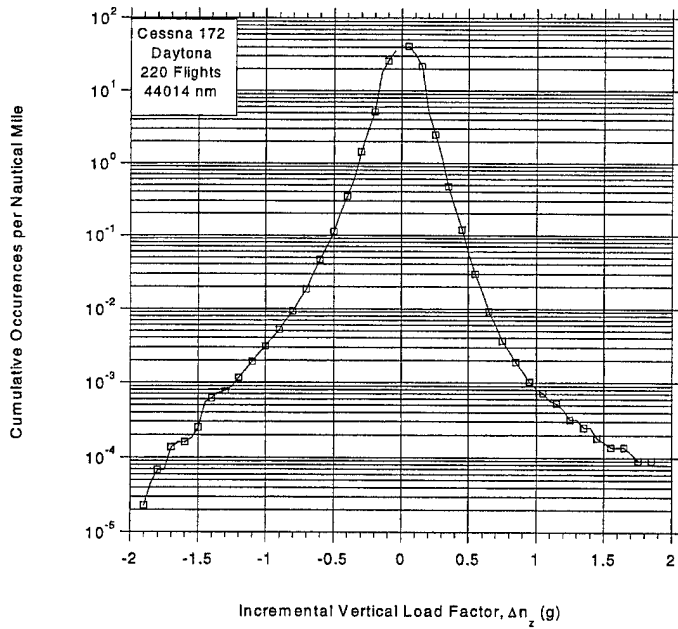

FIGURE B-23. CUMULATIVE OCCURRENCES OF INCREMENTAL GUST LOAD FACTOR PER NAUTICAL MILE

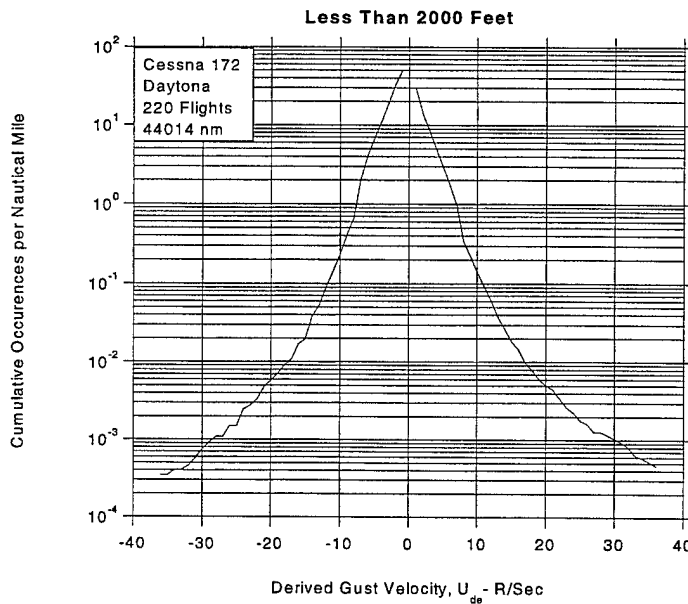

FIGURE B-24. CUMULATIVE OCCURRENCES OF DERIVED GUST VELOCITY PER NAUTICAL MILE FOR < 2000 feet

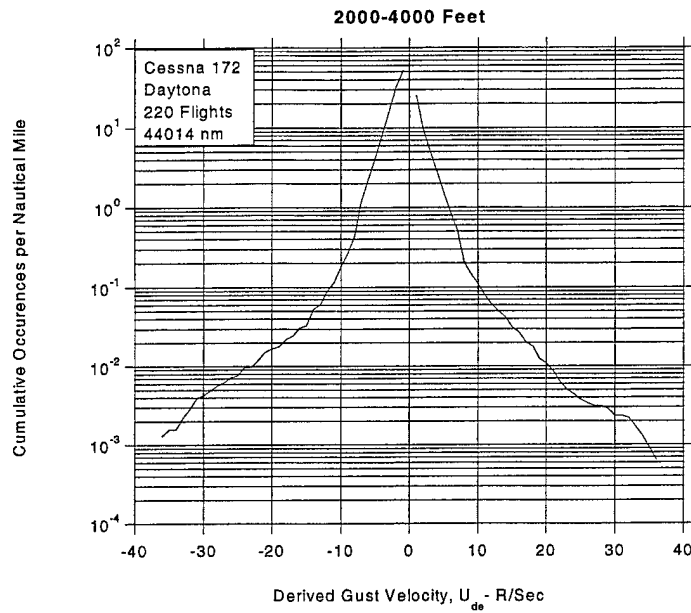

FIGURE B-25. CUMULATIVE OCCURRENCES OF DERIVED GUST VELOCITY PER NAUTICAL MILE FOR 2000-4000 feet

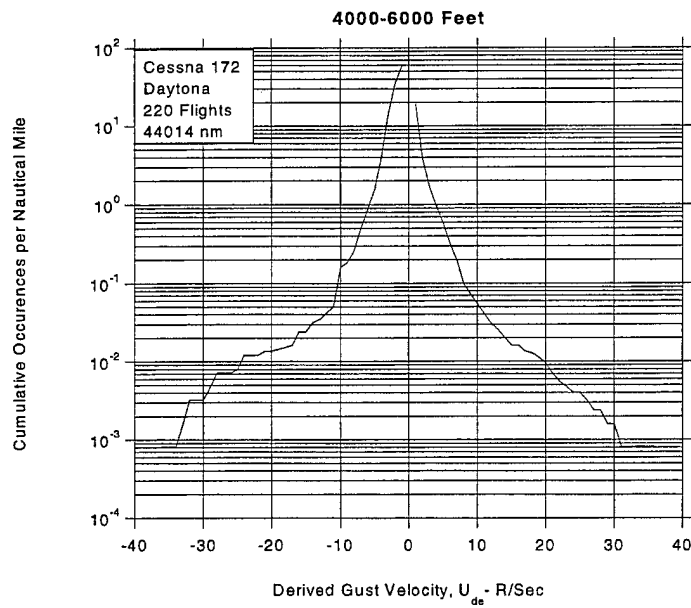

FIGURE B-26. CUMULATIVE OCCURRENCES OF DERIVED GUST VELOCITY PER NAUTICAL MILE FOR 4000-6000 feet

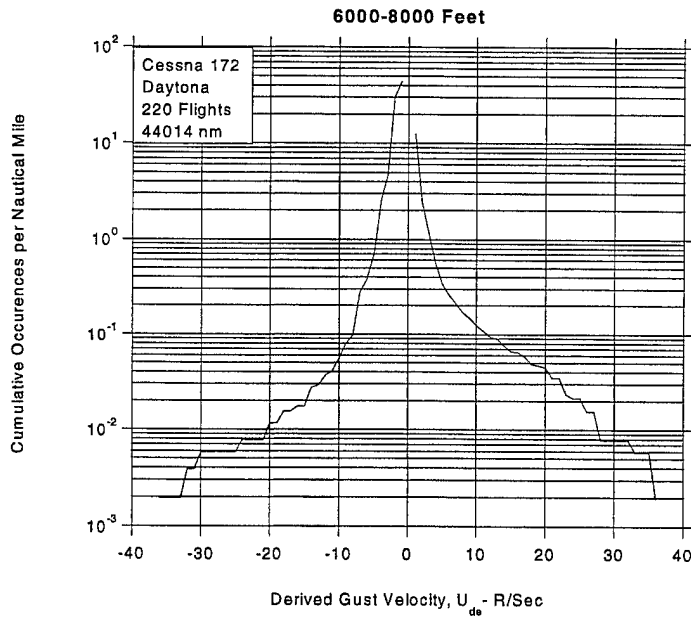

FIGURE B-27. CUMULATIVE OCCURRENCES OF DERIVED GUST VELOCITY PER NAUTICAL MILE FOR 6000-8000 feet

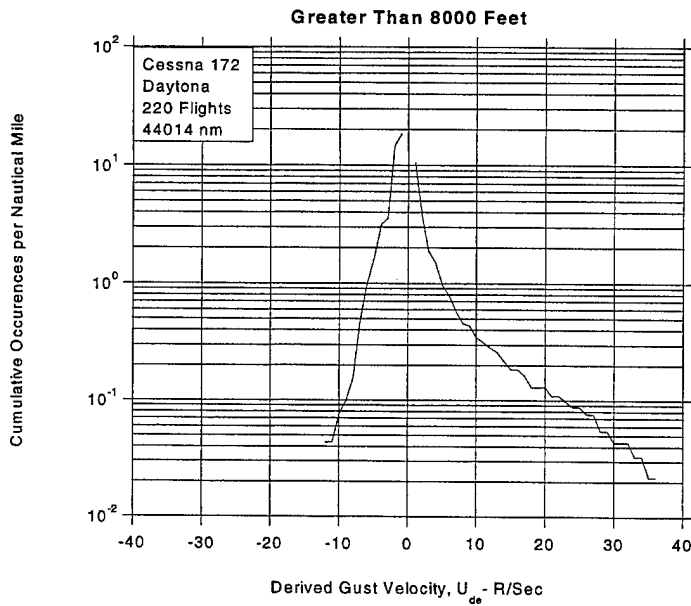

FIGURE B-28. CUMULATIVE OCCURRENCES OF DERIVED GUST VELOCITY PER NAUTICAL MILE FOR >8000 feet

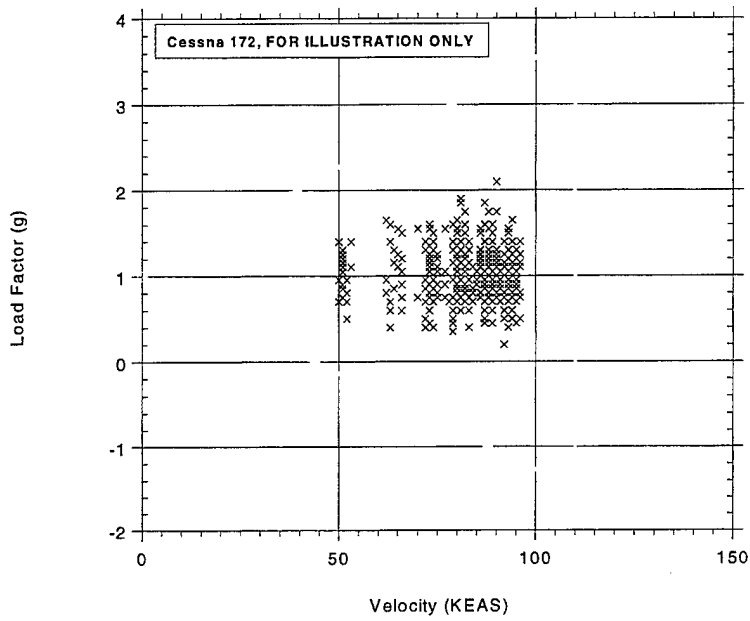

FIGURE B-29. COINCIDENT GUST LOAD FACTOR AND SPEED DURING DEPARTURE

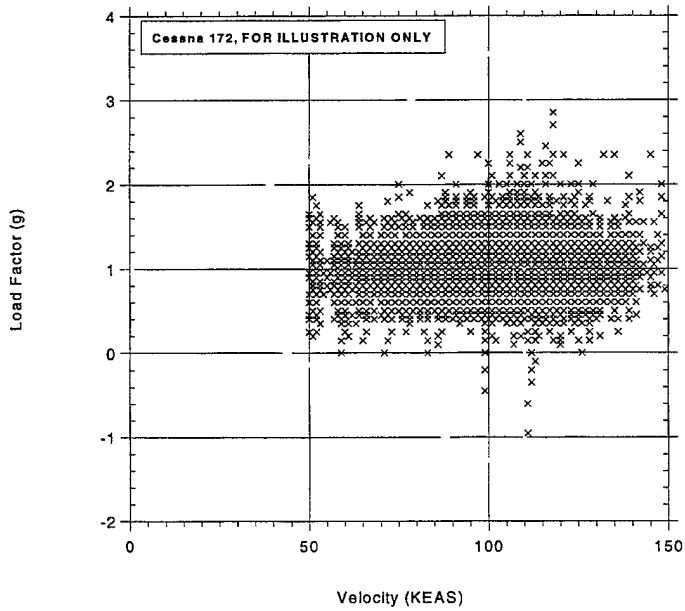

FIGURE B-30. COINCIDENT GUST LOAD FACTOR AND SPEED DURING APPROACH

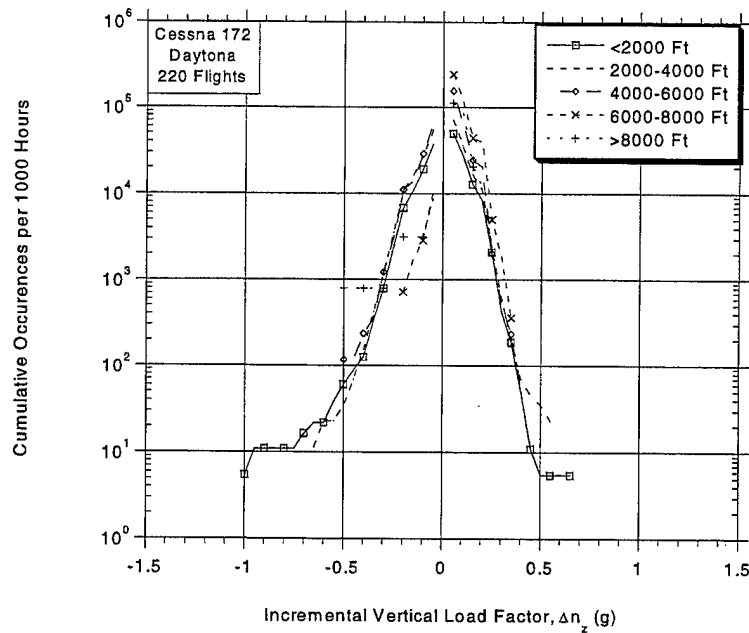

FIGURE B-31. CUMULATIVE OCCURRENCES OF INCREMENTAL MANEUVER LOAD FACTOR PER 1000 HOURS BY PRESSURE ALTITUDE FOR COMBINED CLIMB, CRUISE, AND DESCENT PHASES

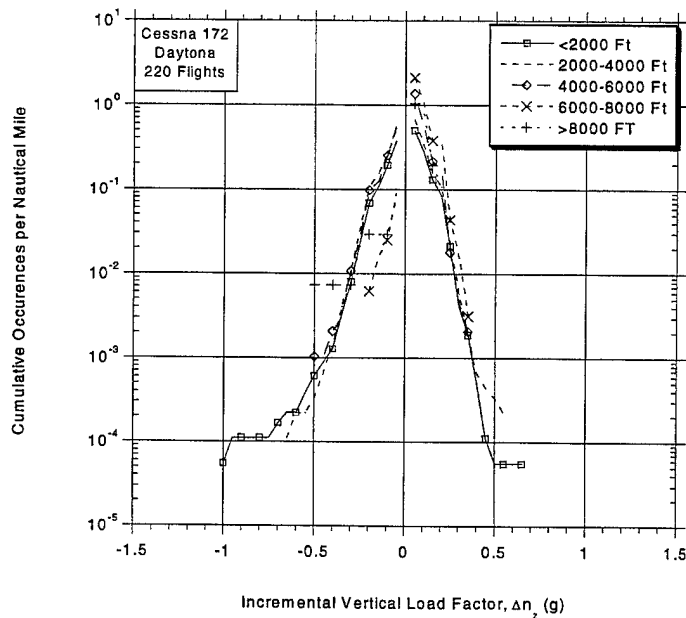

FIGURE B-32. CUMULATIVE OCCURRENCES OF INCREMENTAL MANEUVER LOAD FACTOR PER NAUTICAL MILE BY PRESSURE ALTITUDE FOR COMBINED CLIMB, CRUISE, AND DESCENT PHASES

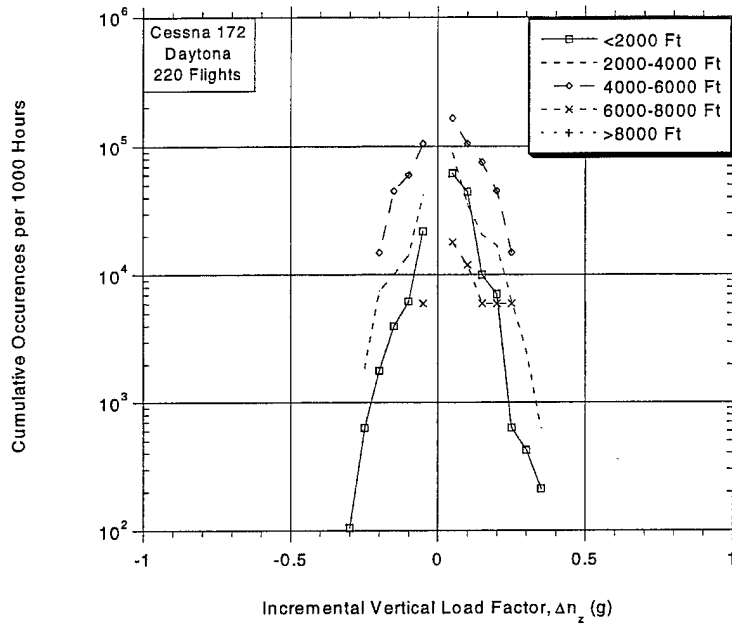

FIGURE B-33. CUMULATIVE OCCURRENCES OF INCREMENTAL MANEUVER LOAD FACTOR PER 1000 HOURS BY ALTITUDE ABOVE AIRPORT FOR DEPARTURE PHASE

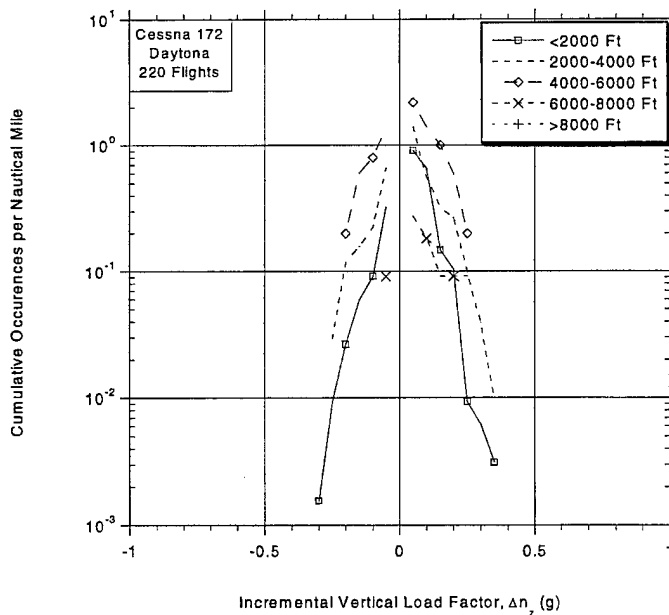

FIGURE B-34. CUMULATIVE OCCURRENCES OF INCREMENTAL MANEUVER LOAD FACTOR PER NAUTICAL MILE BY ALTITUDE ABOVE AIRPORT FOR DEPARTURE PHASE

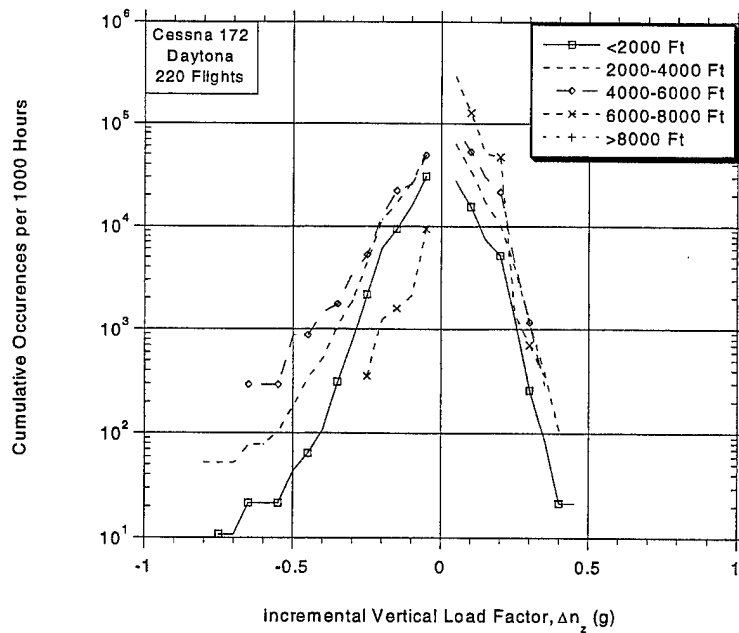

FIGURE B-35. CUMULATIVE OCCURRENCES OF INCREMENTAL MANEUVER LOAD FACTOR PER 1000 HOURS BY ALTITUDE ABOVE AIRPORT FOR APPROACH PHASE

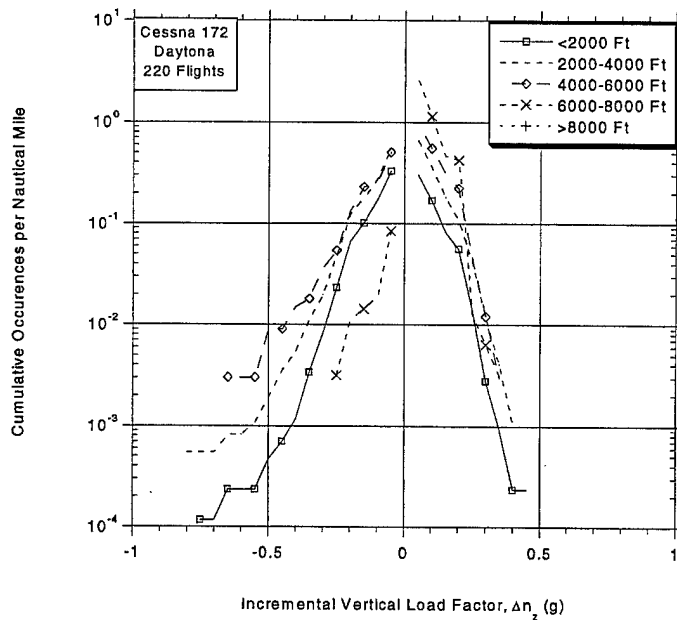

FIGURE B-36. CUMULATIVE OCCURRENCES OF INCREMENTAL MANEUVER LOAD FACTOR PER NAUTICAL MILE BY ALTITUDE ABOVE AIRPORT FOR APPROACH PHASE

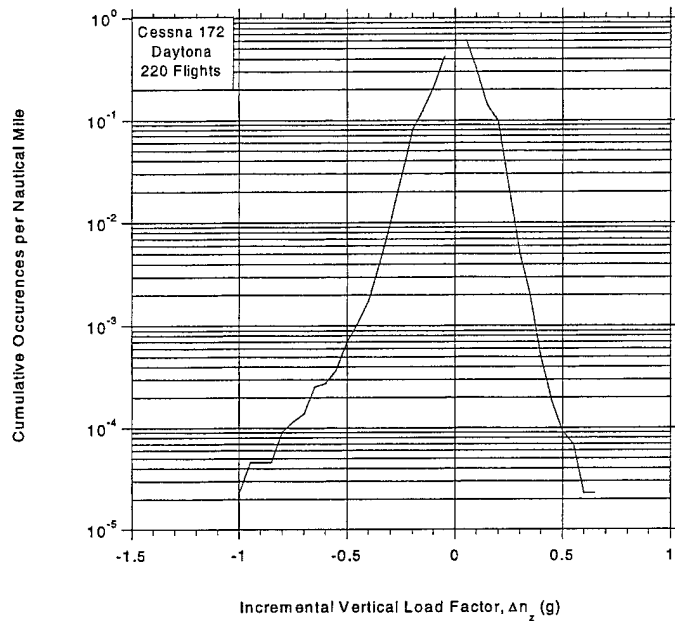

FIGURE B-37. CUMULATIVE OCCURRENCES OF INCREMENTAL MANEUVER LOAD FACTOR PER NAUTICAL MILE

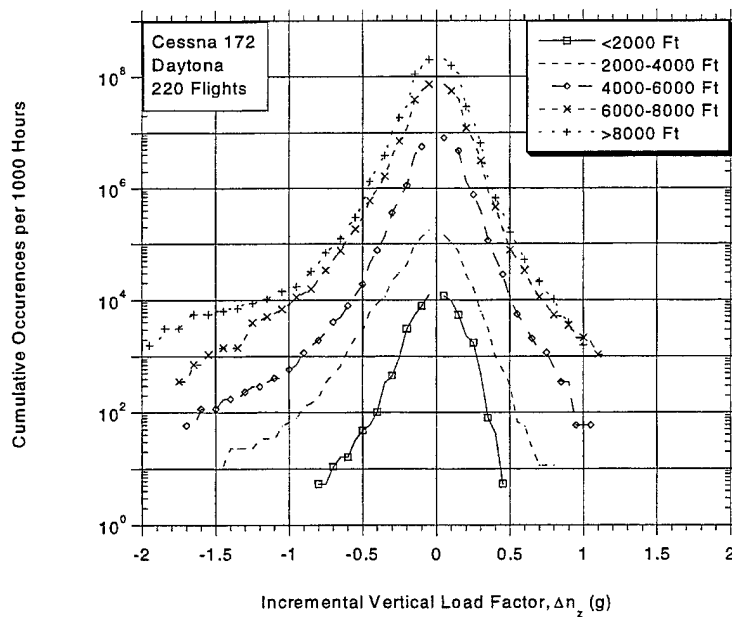

FIGURE B-38. CUMULATIVE OCCURRENCES OF INCREMENTAL LOAD FACTOR PER 1000 HOURS BY PRESSURE ALTITUDE FOR COMBINED CLIMB, CRUISE, AND DESCENT PHASES

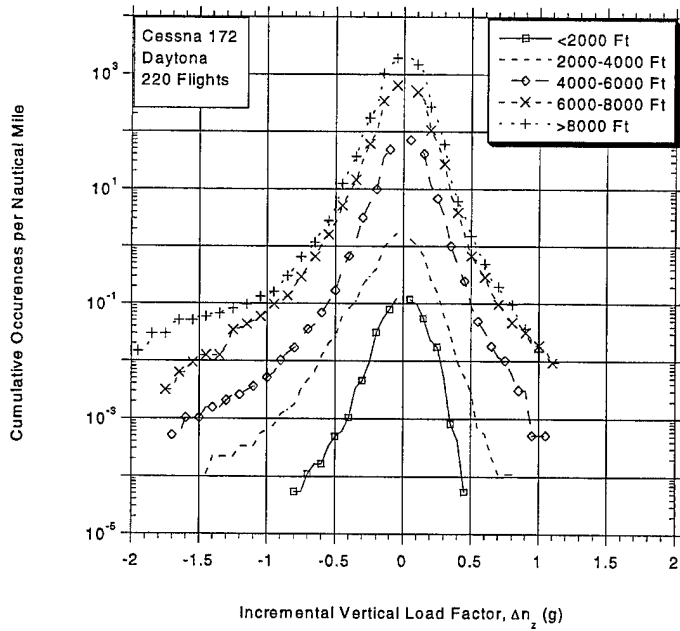

FIGURE B-39. CUMULATIVE OCCURRENCES OF INCREMENTAL LOAD FACTOR PER NAUTICAL MILE BY PRESSURE ALTITUDE FOR COMBINED CLIMB, CRUISE, AND DESCENT PHASES

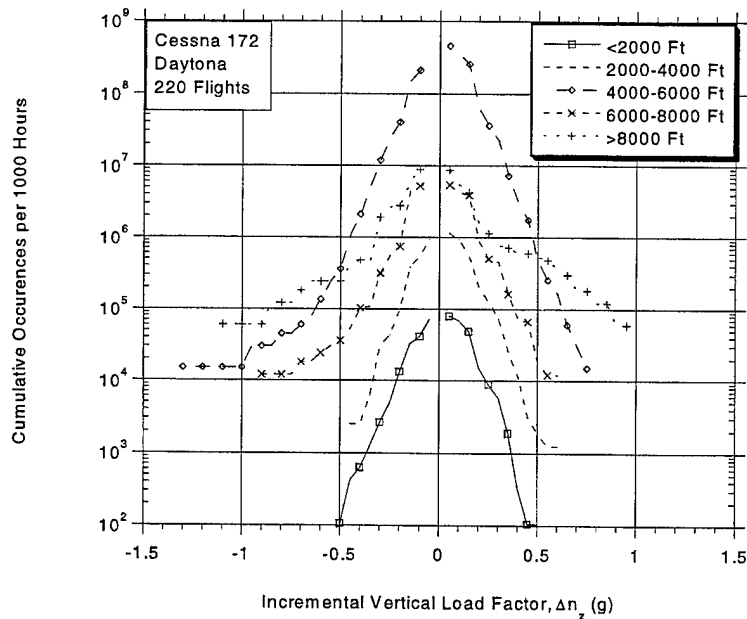

FIGURE B-40. CUMULATIVE OCCURRENCES OF INCREMENTAL LOAD FACTOR PER 1000 HOURS BY ALTITUDE ABOVE AIRPORT FOR DEPARTURE PHASE

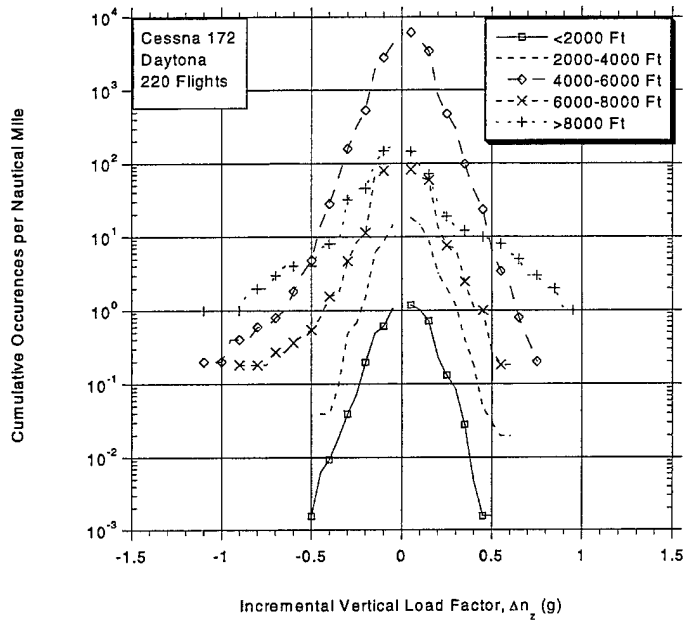

FIGURE B-41. CUMULATIVE OCCURRENCES OF INCREMENTAL LOAD FACTOR PER NAUTICAL MILE BY ALTITUDE ABOVE AIRPORT FOR DEPARTURE PHASE

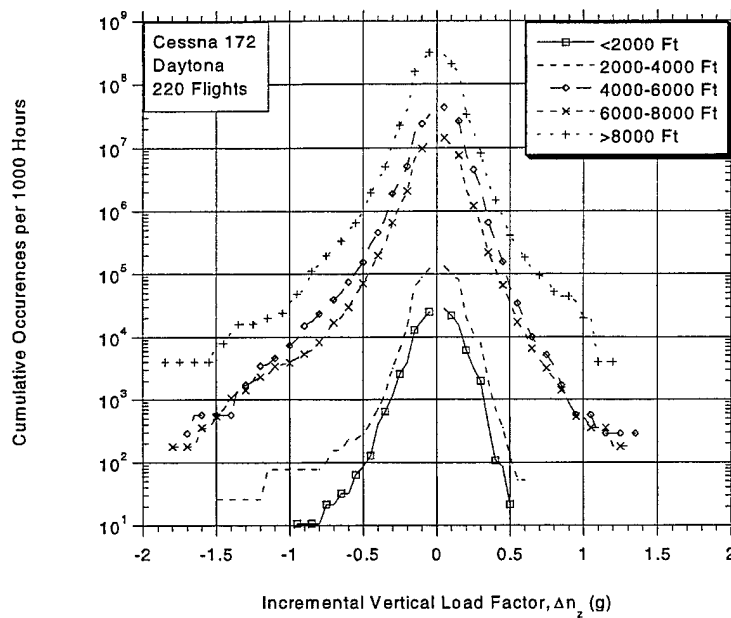

FIGURE B-42. CUMULATIVE OCCURRENCES OF INCREMENTAL LOAD FACTOR PER 1000 HOURS BY ALTITUDE ABOVE AIRPORT FOR APPROACH PHASE

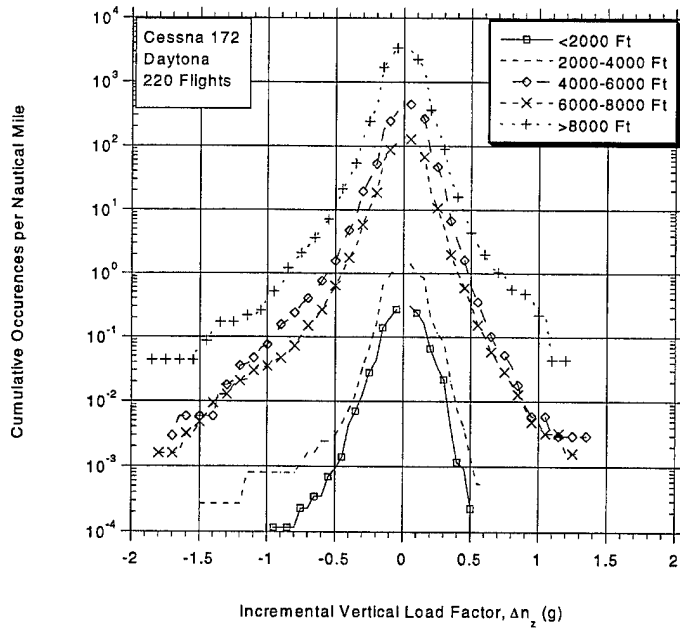

FIGURE B-43. CUMULATIVE OCCURRENCES OF INCREMENTAL LOAD FACTOR PER NAUTICAL MILE BY ALTITUDE ABOVE AIRPORT FOR APPROACH PHASE

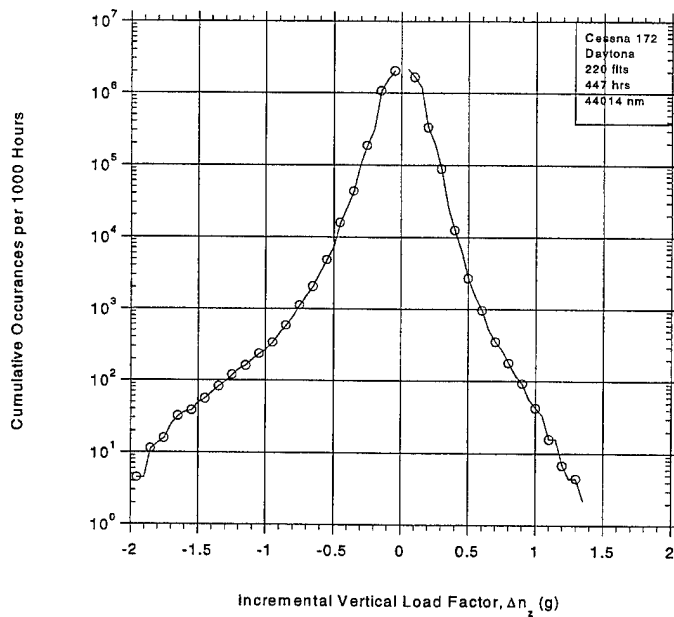

FIGURE B-44. CUMULATIVE OCCURRENCES OF INCREMENTAL LOAD FACTOR PER 1000 HOURS FOR COMBINED FLIGHT PHASES

APPENDIX C—STATISTICAL FORMATS, AIRCRAFT USAGE DATA,
PRESCOTT AIRCRAFT

		Maximum Altitude (1000 feet)			
		0-5	5-10	10-15	Total
Flight Distance (nm)	0-50	31%	44%	0%	75%
	50-100	0%	21%	0%	21%
	100-150	0%	3%	0%	3%
	150-200	0%	1%	0%	1%
	200-250	0%	0%	0%	0%
	250-300	0%	0%	0%	0%
	300-350	0%	0%	0%	0%
	350-400	0%	0%	0%	0%
	400-450	0%	0%	0%	0%
	Total	31%	69%	0%	100%

FIGURE C-1. CORRELATION OF MAXIMUM ALTITUDE AND FLIGHT DISTANCE, PERCENT OF FLIGHTS

		Total Flight Distance (nm)								
		0-50	50-100	100-150	150-200	200-250	250-300	300-350	350-400	400-450
Altitude Band (feet)	0-5k	42%	0%	0%	0%	0%	0%	0%	0%	0%
	5k-10k	58%	100%	100%	100%	0%	0%	0%	0%	0%
	10k-15k	0%	0%	0%	0%	0%	0%	0%	0%	0%
	Total	100%	100%	100%	100%	0%	0%	0%	0%	0%
	Number of Flights	257	72	10	3	0	0	0	0	0

FIGURE C-2. PERCENT OF TOTAL DISTANCE IN ALTITUDE BANDS

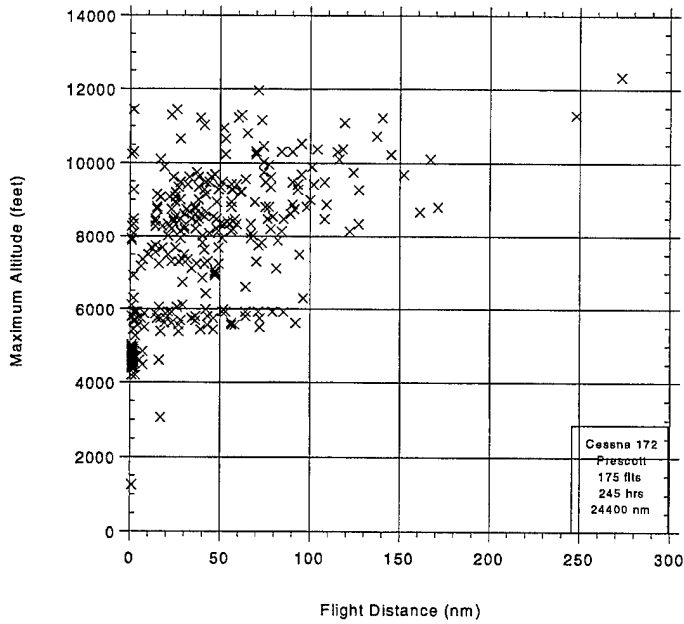

FIGURE C-3. COINCIDENT FLIGHT DISTANCE AND MAXIMUM FLIGHT ALTITUDE

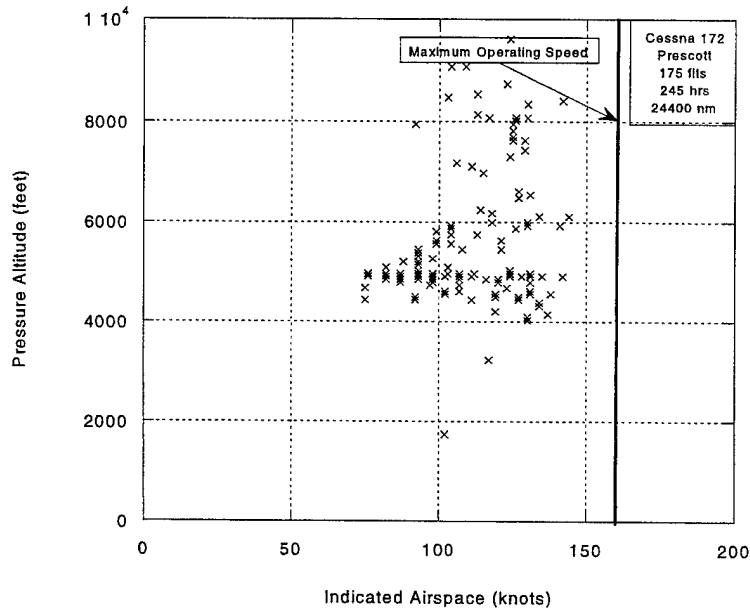

FIGURE C-4. COINCIDENT ALTITUDE AT MAXIMUM INDICATED AIRSPEED, ALL FLIGHT PHASES

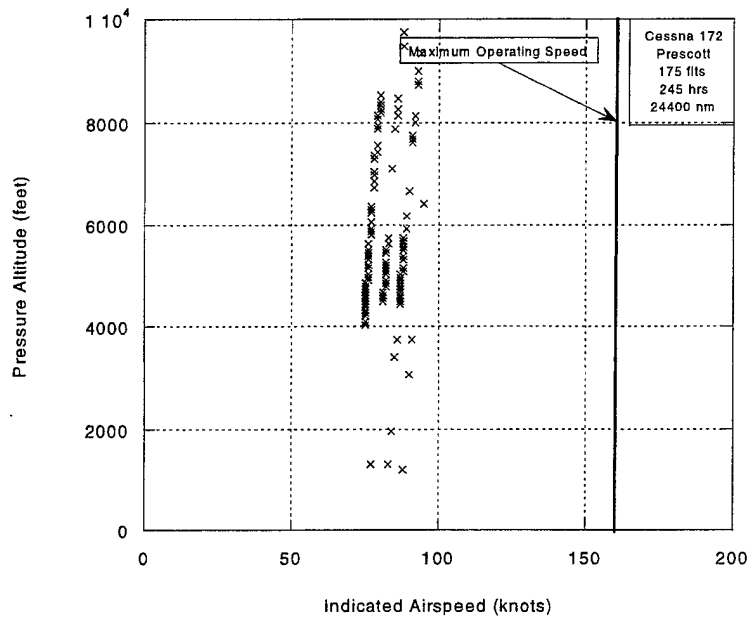

FIGURE C-5. MAXIMUM SPEED AND COINCIDENT ALTITUDE DURING CLIMB

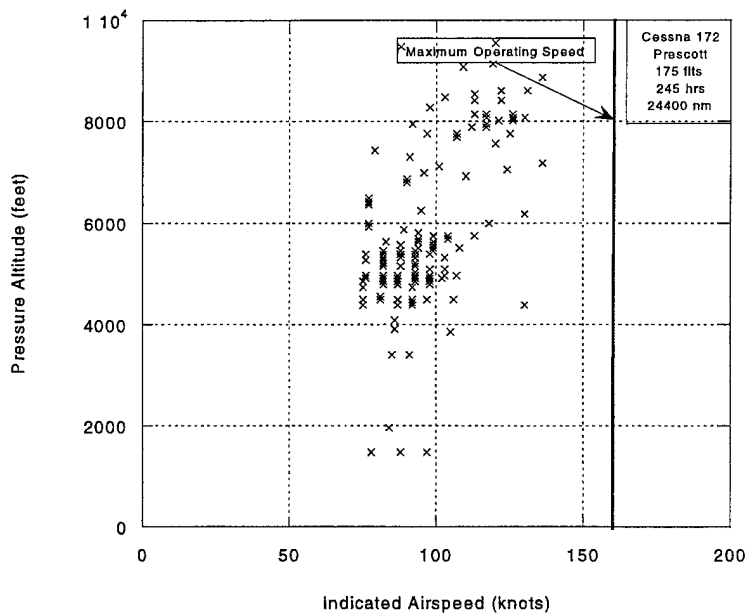

FIGURE C-6. MAXIMUM SPEED AND COINCIDENT ALTITUDE DURING CRUISE

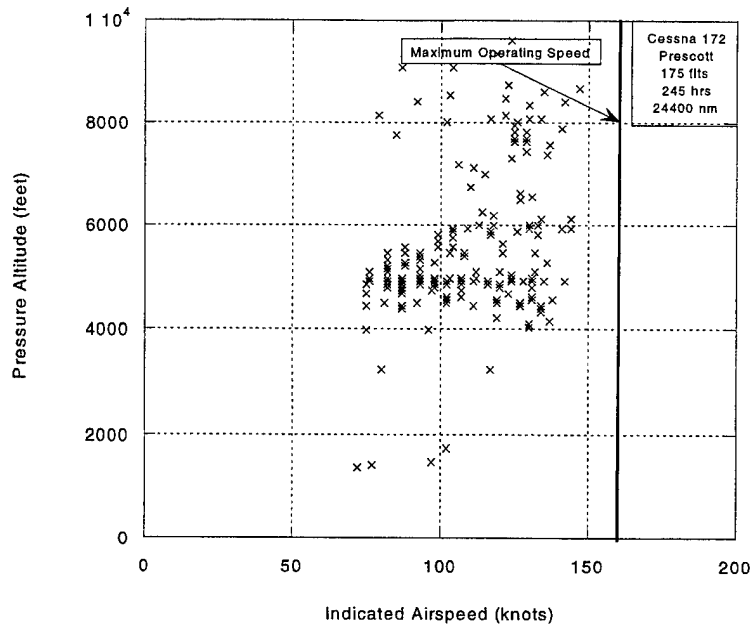

FIGURE C-7. MAXIMUM SPEED AND COINCIDENT ALTITUDE DURING DESCENT

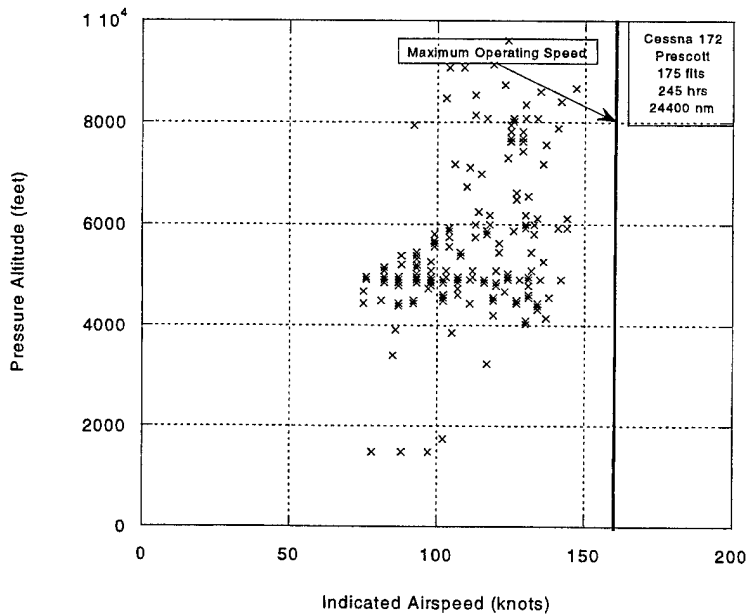

FIGURE C-8. MAXIMUM SPEED AND COINCIDENT ALTITUDE DURING ALL FLIGHT PHASES

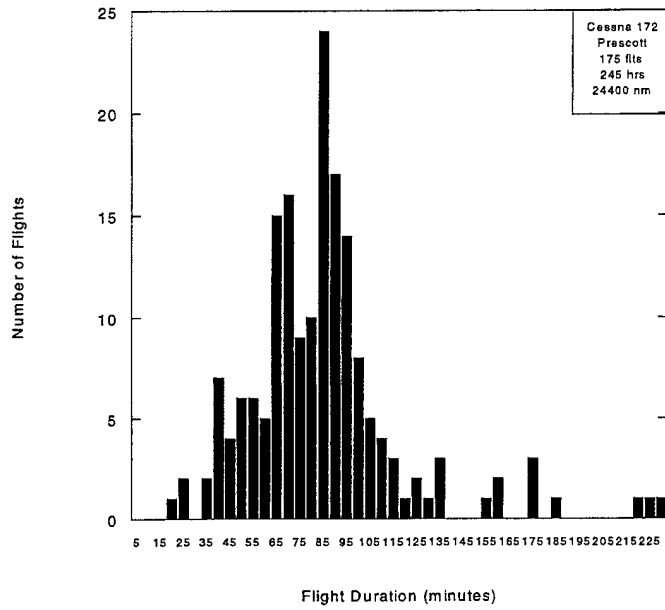

FIGURE C-9. NUMBER OF FLIGHTS VS FLIGHT DURATION

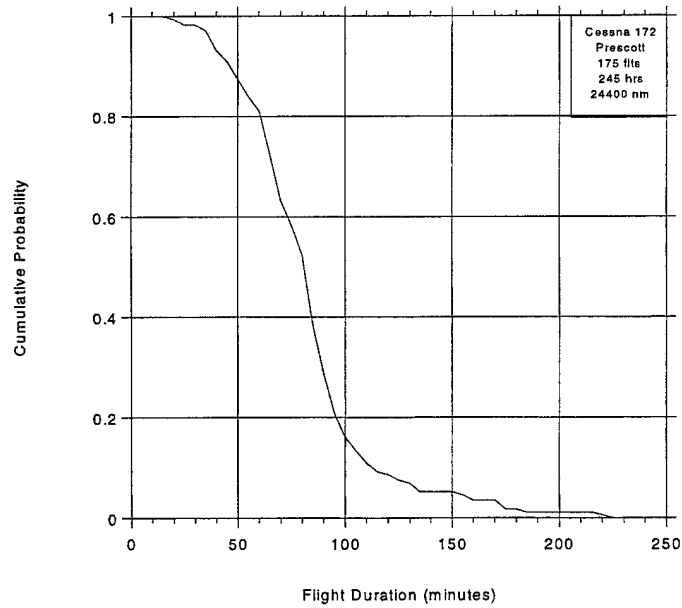

FIGURE C-10. CUMULATIVE PROBABILITY OF FLIGHT DURATION

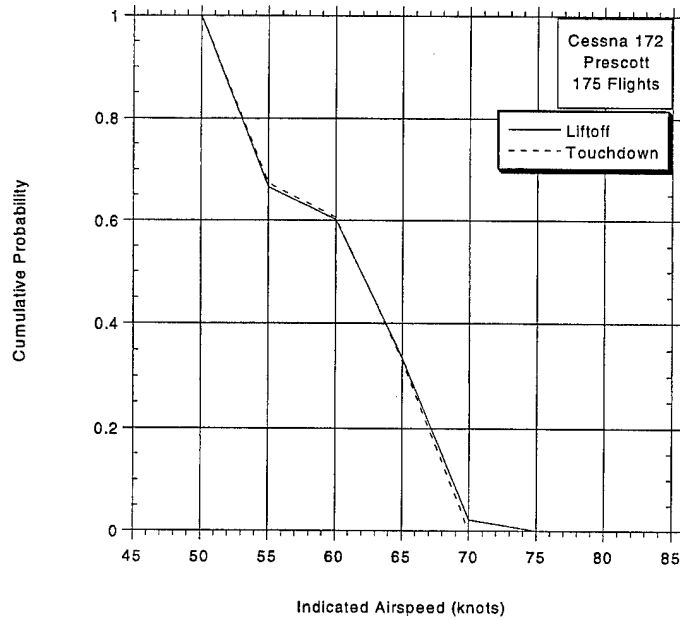

FIGURE C-11. CUMULATIVE PROBABILITY OF AIRSPEED AT LIFTOFF AND TOUCHDOWN

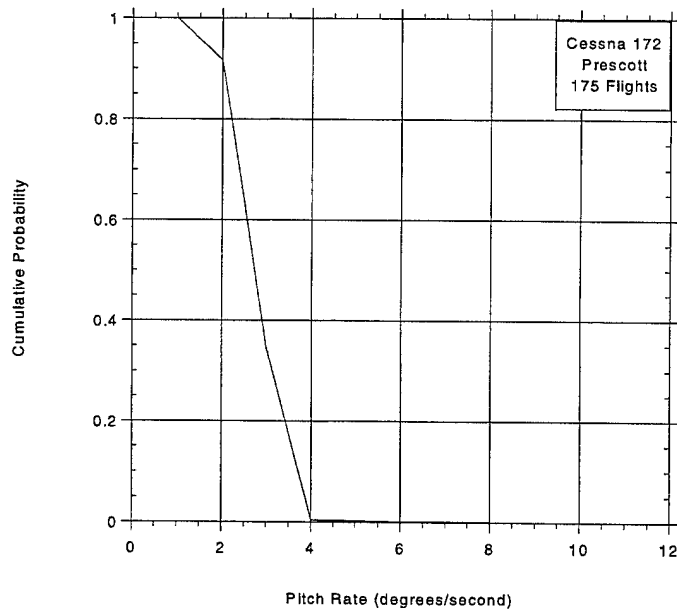

FIGURE C-12. CUMULATIVE PROBABILITY OF PITCH RATE AT LIFTOFF

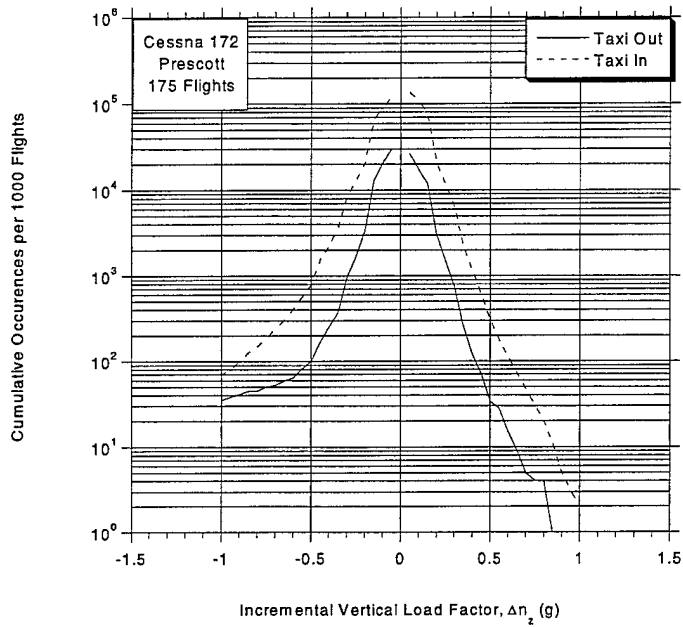

FIGURE C-13. CUMULATIVE FREQUENCY OF INCREMENTAL VERTICAL LOAD FACTOR DURING TAXI OPERATIONS

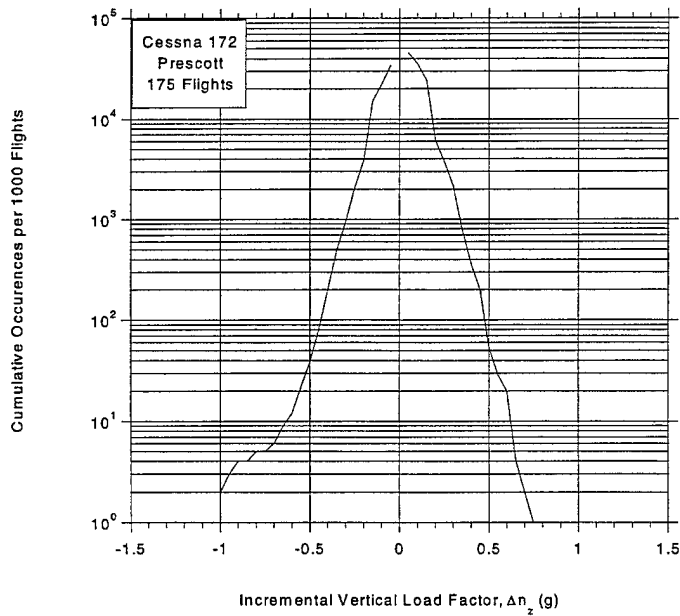

FIGURE C-14. CUMULATIVE OCCURRENCES OF INCREMENTAL VERTICAL LOAD FACTOR DURING TAKEOFF ROLL

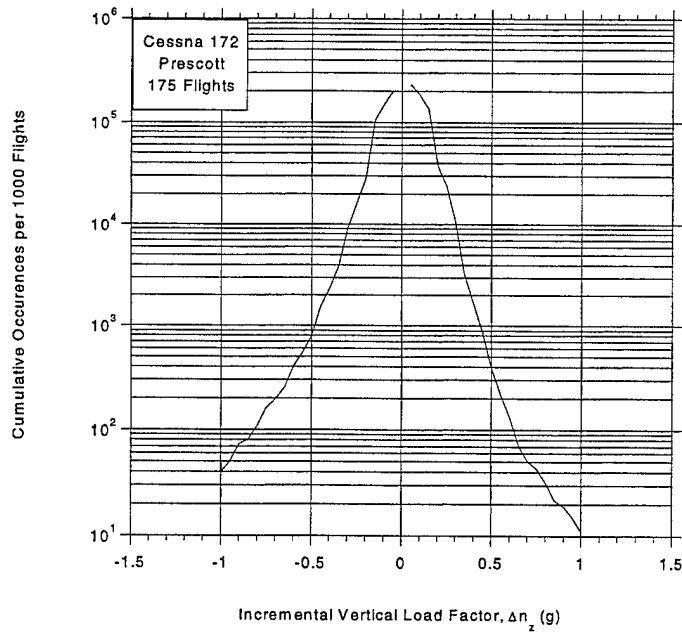

FIGURE C-15. CUMULATIVE OCCURRENCES OF INCREMENTAL VERTICAL LOAD FACTOR DURING LANDING ROLL

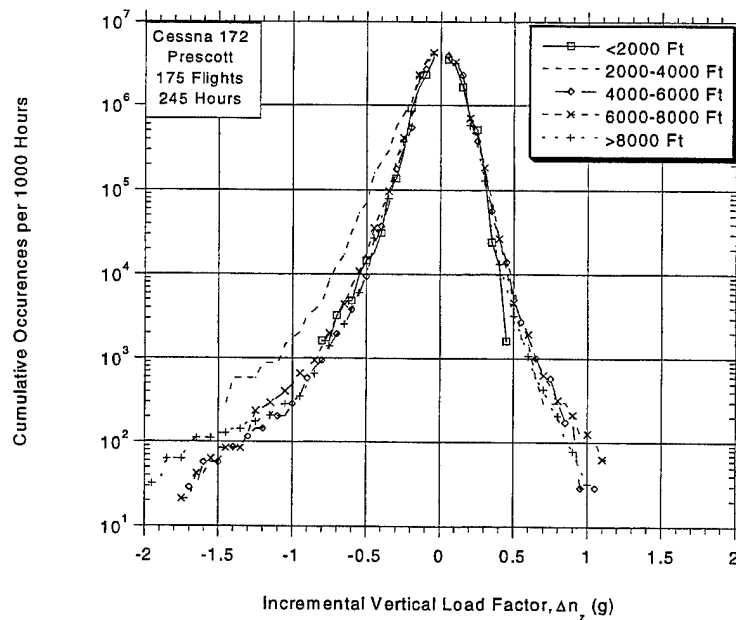

FIGURE C-16. CUMULATIVE OCCURRENCES OF INCREMENTAL GUST LOAD FACTOR PER 1000 HOURS BY PRESSURE ALTITUDE FOR COMBINED CLIMB, CRUISE, AND DESCENT PHASES

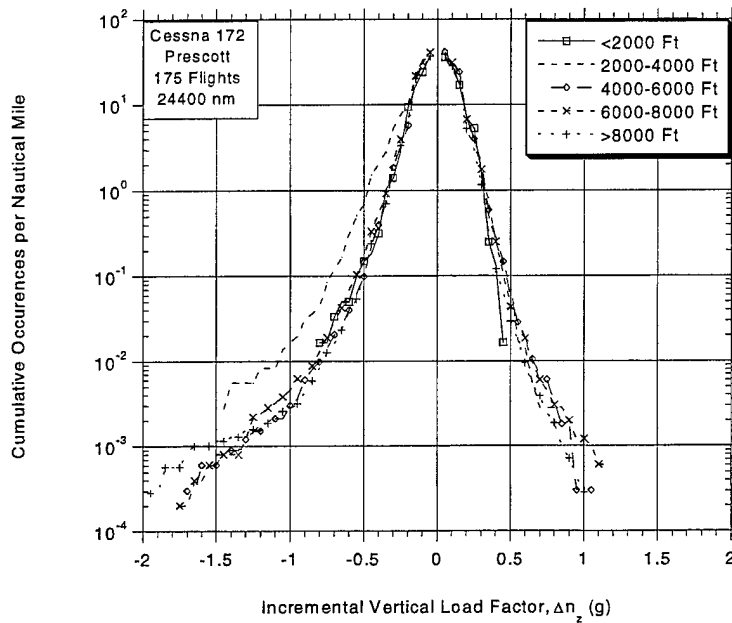

FIGURE C-17. CUMULATIVE OCCURRENCES OF INCREMENTAL GUST LOAD FACTOR PER NAUTICAL MILE BY PRESSURE ALTITUDE FOR COMBINED CLIMB, CRUISE, AND DESCENT PHASES

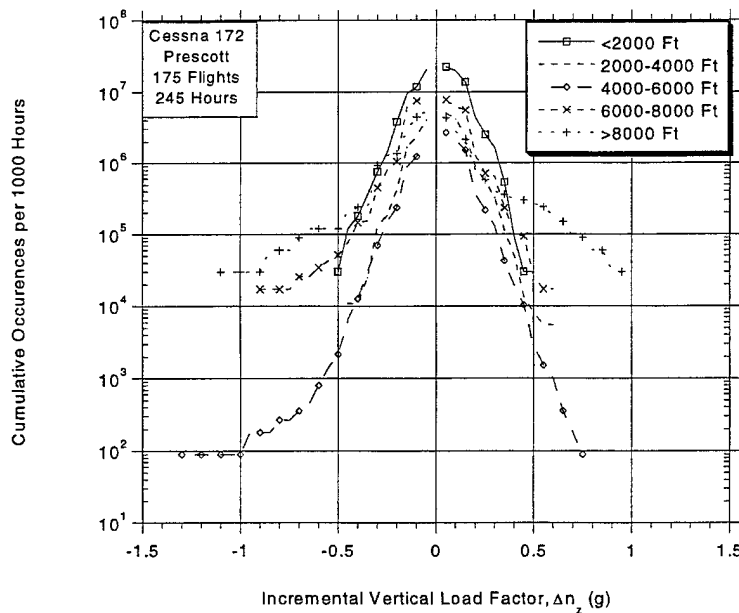

FIGURE C-18. CUMULATIVE OCCURRENCES OF INCREMENTAL GUST LOAD FACTOR PER 1000 HOURS BY ALTITUDE ABOVE AIRPORT FOR DEPARTURE PHASE

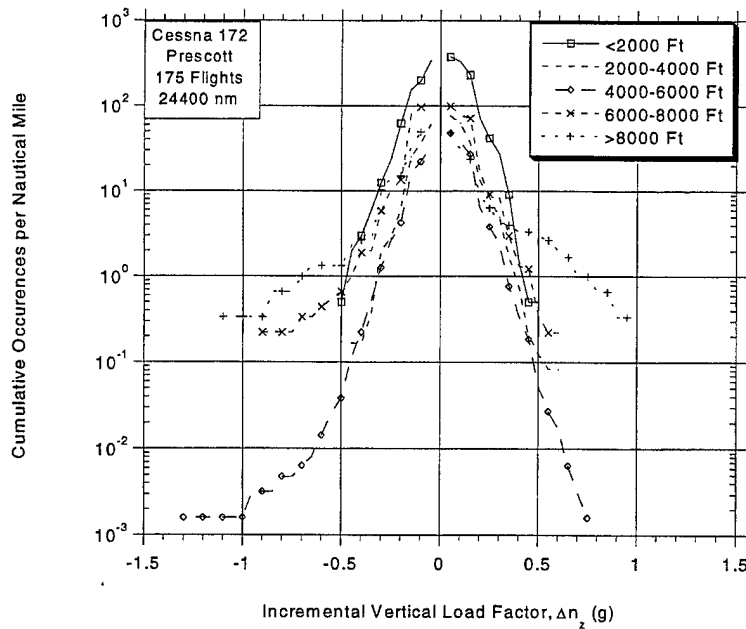

FIGURE C-19. CUMULATIVE OCCURRENCES OF INCREMENTAL GUST LOAD FACTOR PER NAUTICAL MILE BY ALTITUDE ABOVE AIRPORT FOR DEPARTURE PHASE

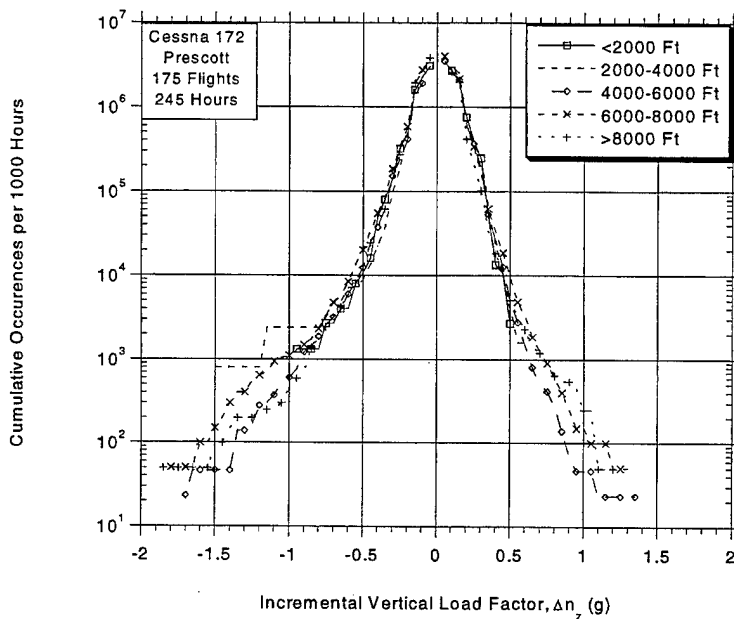

FIGURE C-20. CUMULATIVE OCCURRENCES OF INCREMENTAL GUST LOAD FACTOR PER 1000 HOURS BY ALTITUDE ABOVE AIRPORT FOR APPROACH PHASE

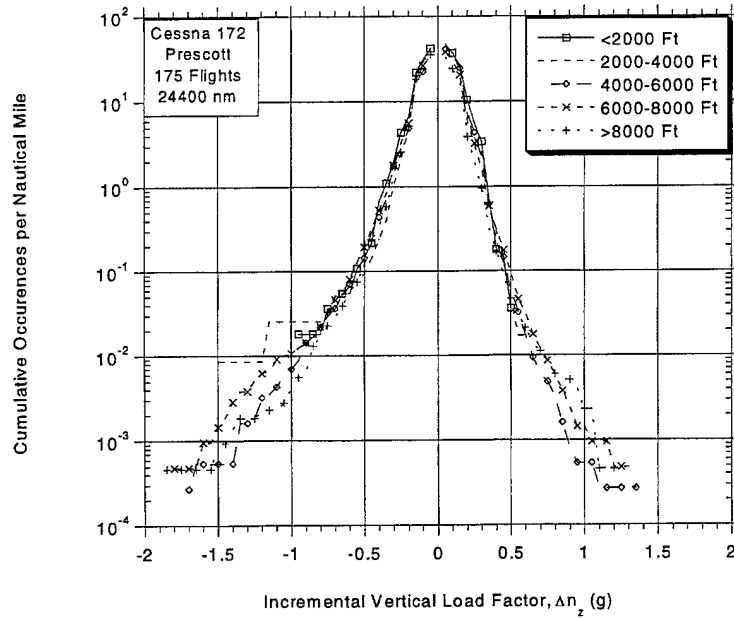

FIGURE C-21. CUMULATIVE OCCURRENCES OF INCREMENTAL GUST LOAD FACTOR PER NAUTICAL MILE BY ALTITUDE ABOVE AIRPORT FOR APPROACH PHASE

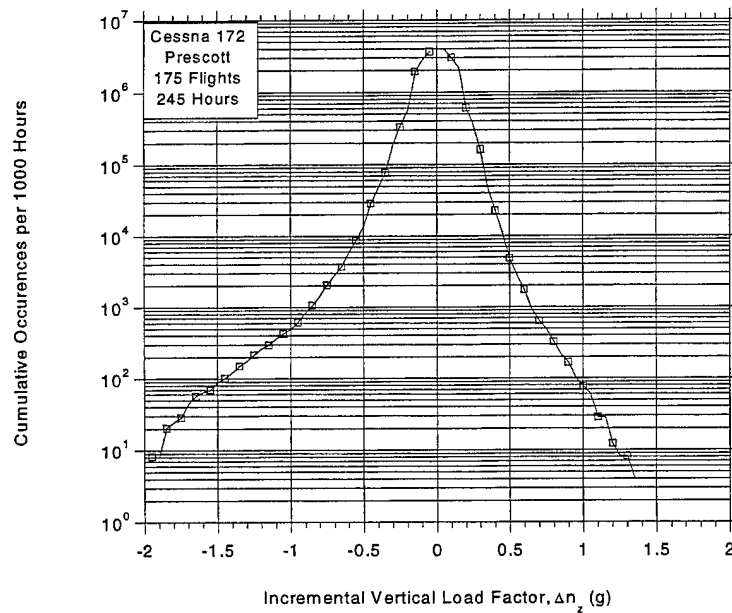

FIGURE C-22. CUMULATIVE OCCURRENCES OF INCREMENTAL GUST LOAD FACTOR PER 1000 HOURS, COMBINED FLIGHT PHASES

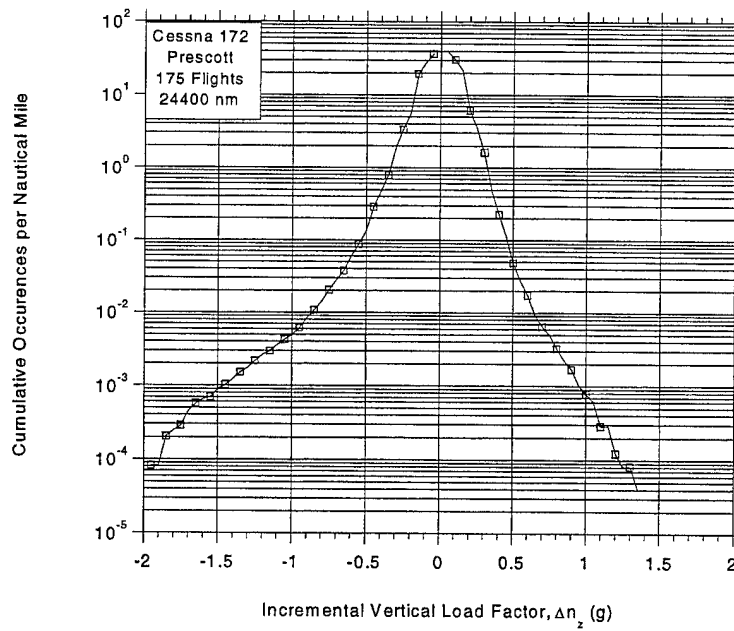

FIGURE C-23. CUMULATIVE OCCURRENCES OF INCREMENTAL GUST LOAD FACTOR PER NAUTICAL MILE

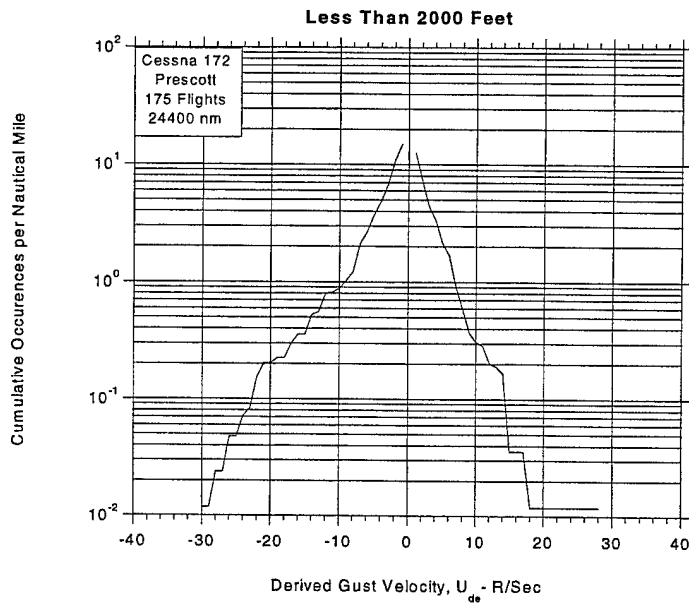

FIGURE C-24. CUMULATIVE OCCURRENCES OF DERIVED GUST VELOCITY PER NAUTICAL MILE FOR < 2000 feet

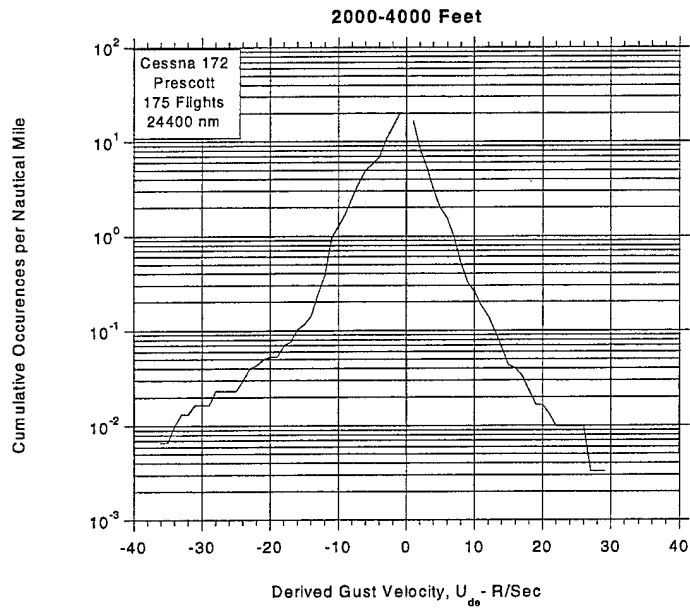

FIGURE C-25. CUMULATIVE OCCURRENCES OF DERIVED GUST VELOCITY PER NAUTICAL MILE FOR 2000-4000 feet

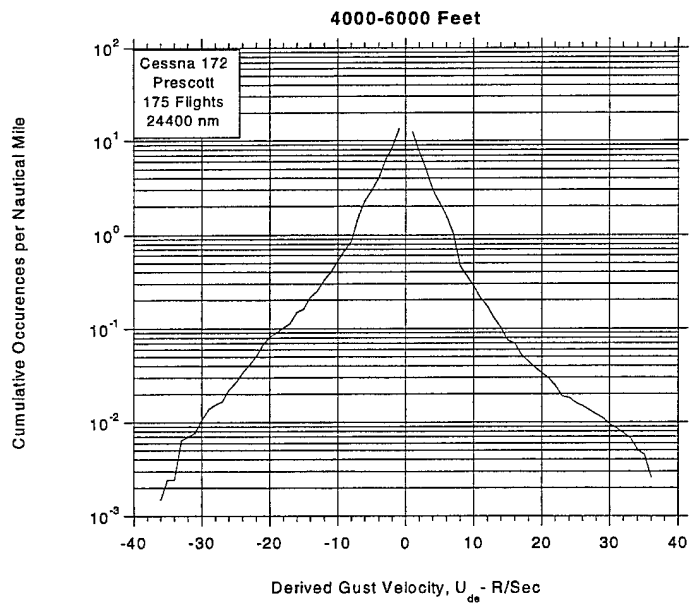

FIGURE C-26. CUMULATIVE OCCURRENCES OF DERIVED GUST VELOCITY PER NAUTICAL MILE FOR 4000-6000 feet

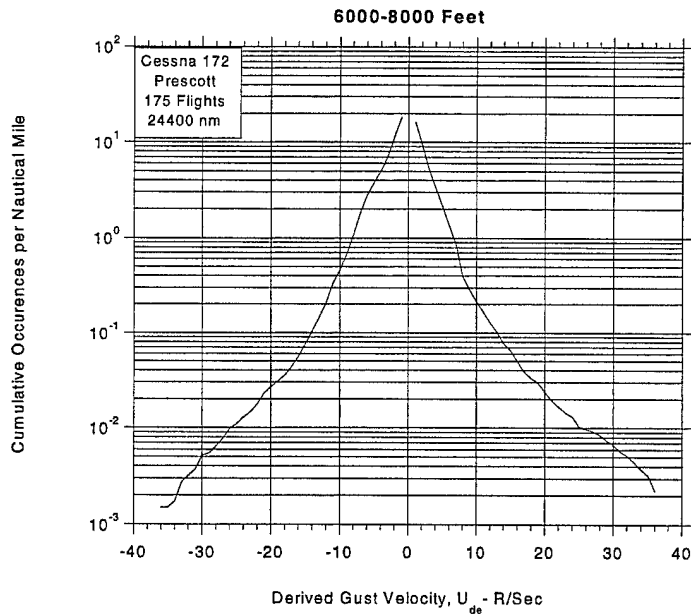

FIGURE C-27. CUMULATIVE OCCURRENCES OF DERIVED GUST VELOCITY PER NAUTICAL MILE FOR 6000-8000 feet

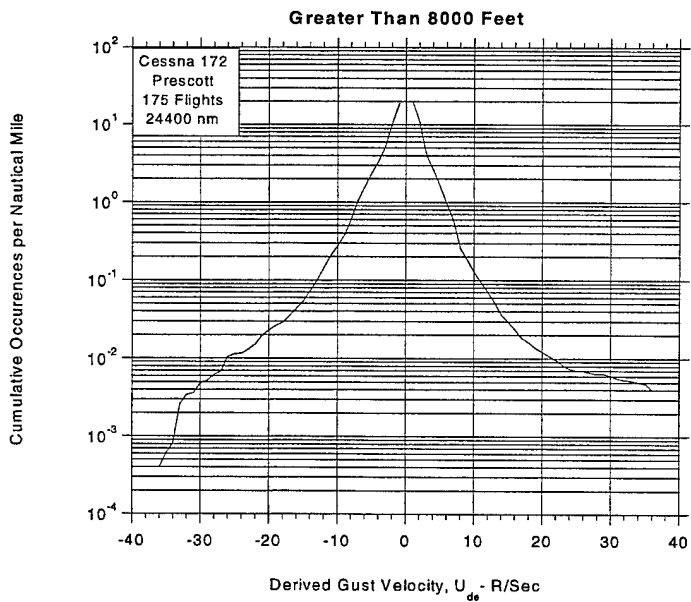

FIGURE C-28. CUMULATIVE OCCURRENCES OF DERIVED GUST VELOCITY PER NAUTICAL MILE FOR >8000 feet

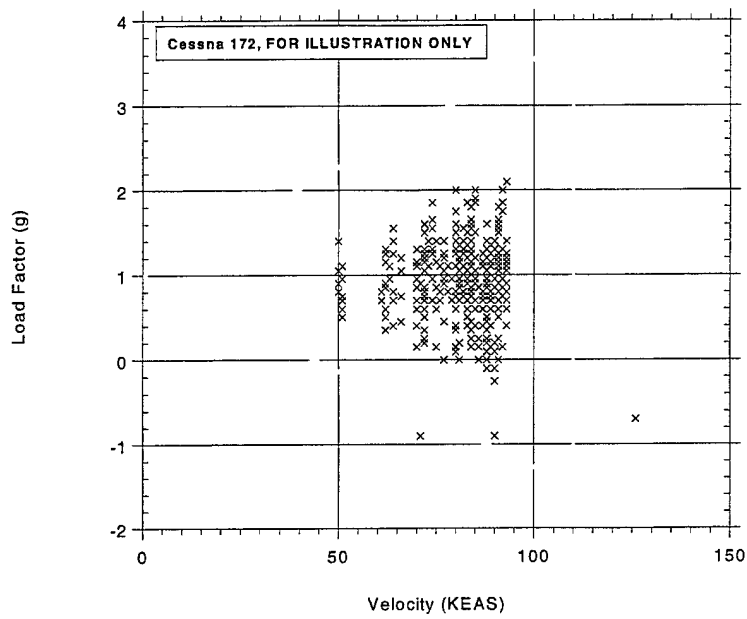

FIGURE C-29. COINCIDENT GUST LOAD FACTOR AND SPEED DURING DEPARTURE

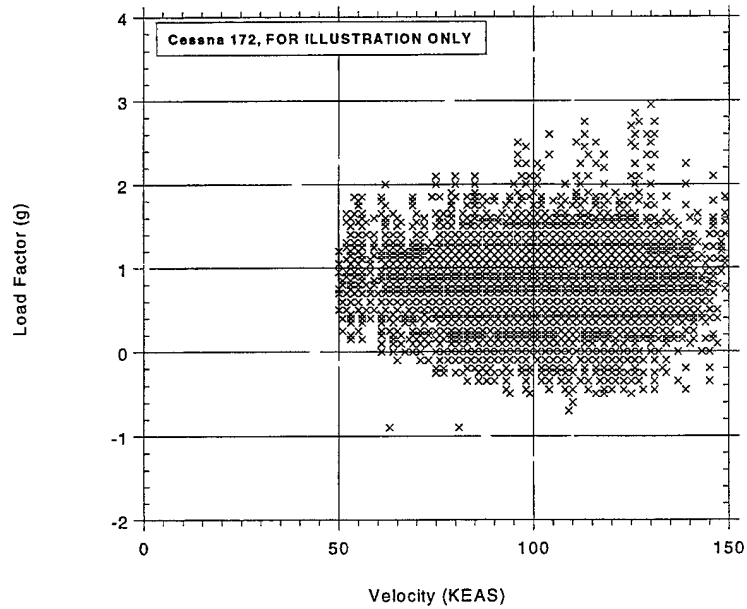

FIGURE C-30. COINCIDENT GUST LOAD FACTOR AND SPEED DURING APPROACH

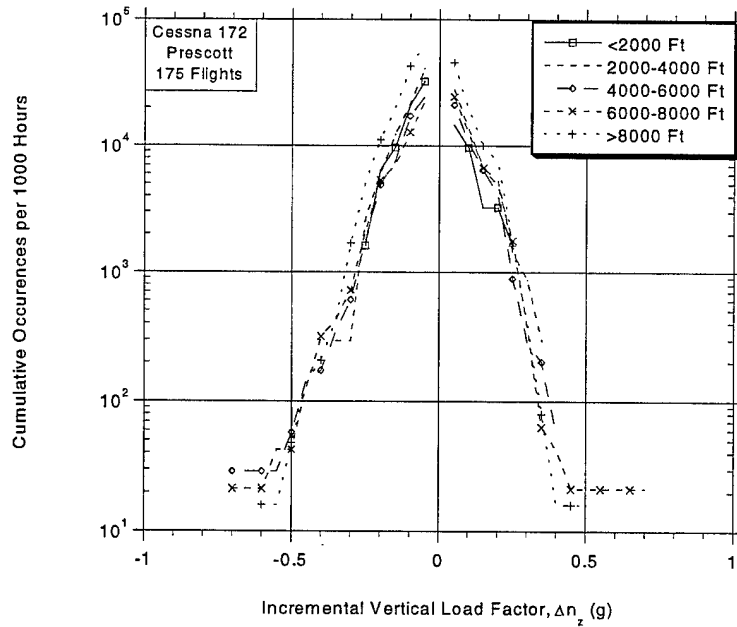

FIGURE C-31. CUMULATIVE OCCURRENCES OF INCREMENTAL MANEUVER LOAD FACTOR PER 1000 HOURS BY PRESSURE ALTITUDE FOR COMBINED CLIMB, CRUISE, AND DESCENT PHASES

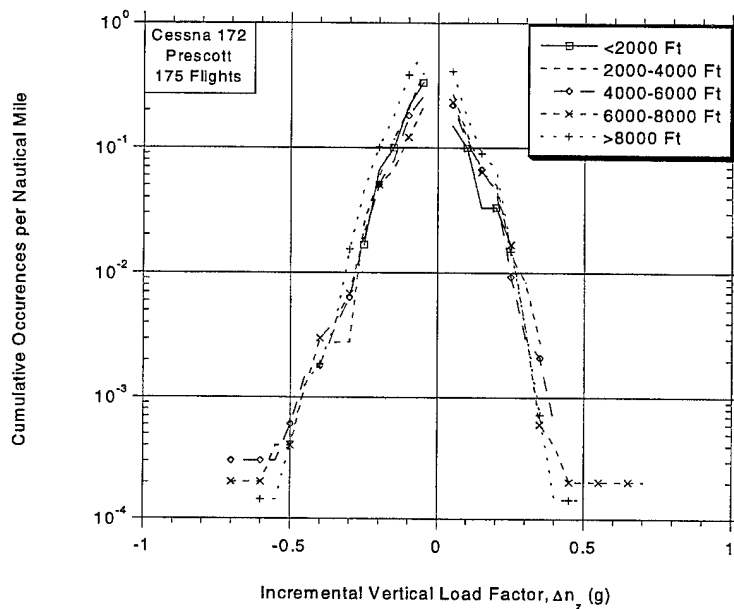

FIGURE C-32. CUMULATIVE OCCURRENCES OF INCREMENTAL MANEUVER LOAD FACTOR PER NAUTICAL MILE BY PRESSURE ALTITUDE FOR COMBINED CLIMB, CRUISE, AND DESCENT PHASES

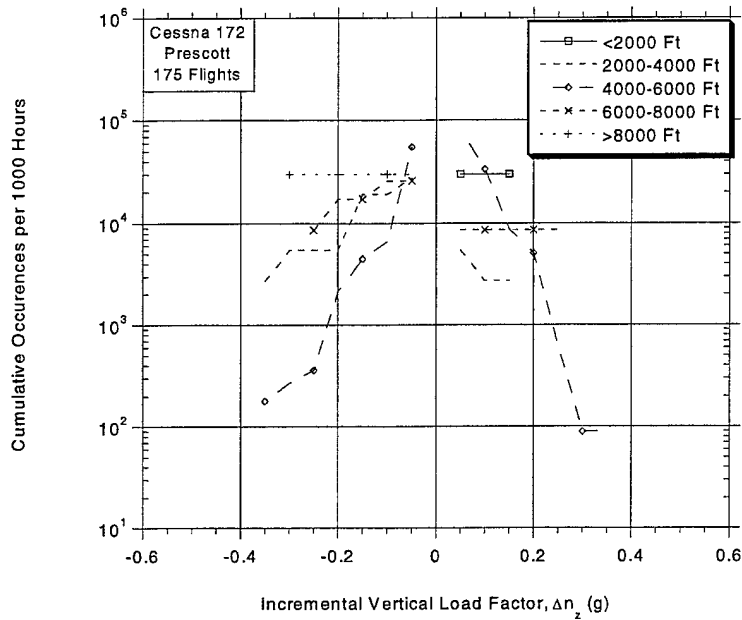

FIGURE C-33. CUMULATIVE OCCURRENCES OF INCREMENTAL MANEUVER LOAD FACTOR PER 1000 HOURS BY ALTITUDE ABOVE AIRPORT FOR DEPARTURE PHASE

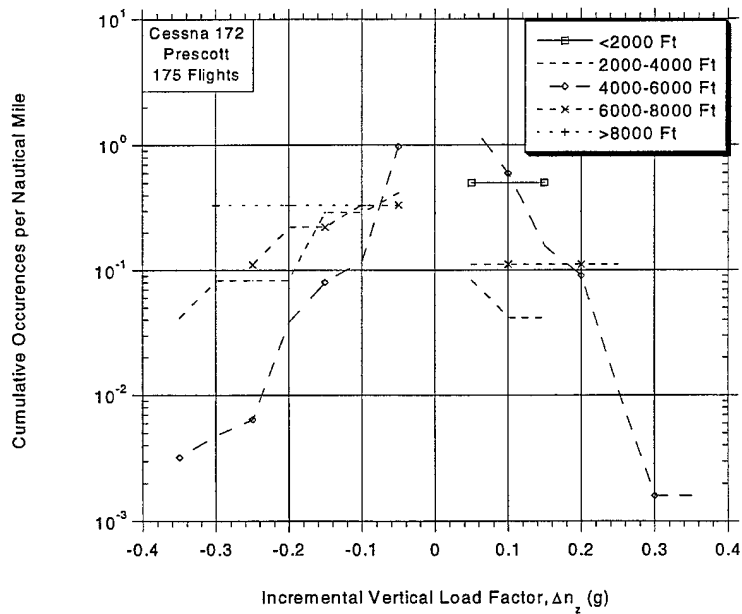

FIGURE C-34. CUMULATIVE OCCURRENCES OF INCREMENTAL MANEUVER LOAD FACTOR PER NAUTICAL MILE BY ALTITUDE ABOVE AIRPORT FOR DEPARTURE PHASE

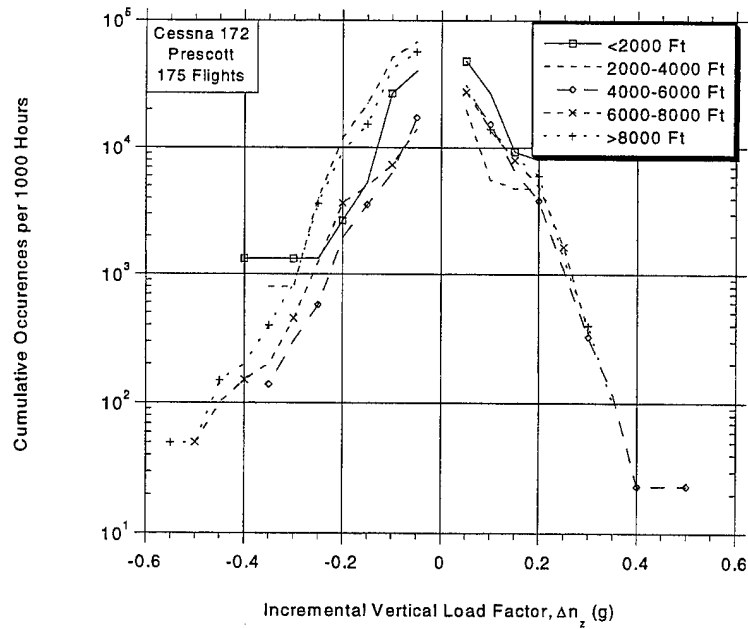

FIGURE C-35. CUMULATIVE OCCURRENCES OF INCREMENTAL MANEUVER LOAD FACTOR PER 1000 HOURS BY ALTITUDE ABOVE AIRPORT FOR APPROACH PHASE

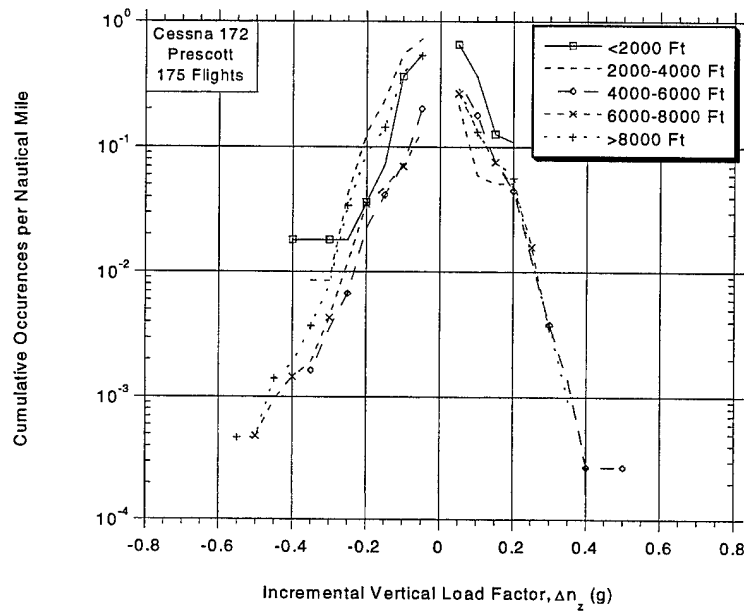

FIGURE C-36. CUMULATIVE OCCURRENCES OF INCREMENTAL MANEUVER LOAD FACTOR PER NAUTICAL MILE BY ALTITUDE ABOVE AIRPORT FOR APPROACH PHASE

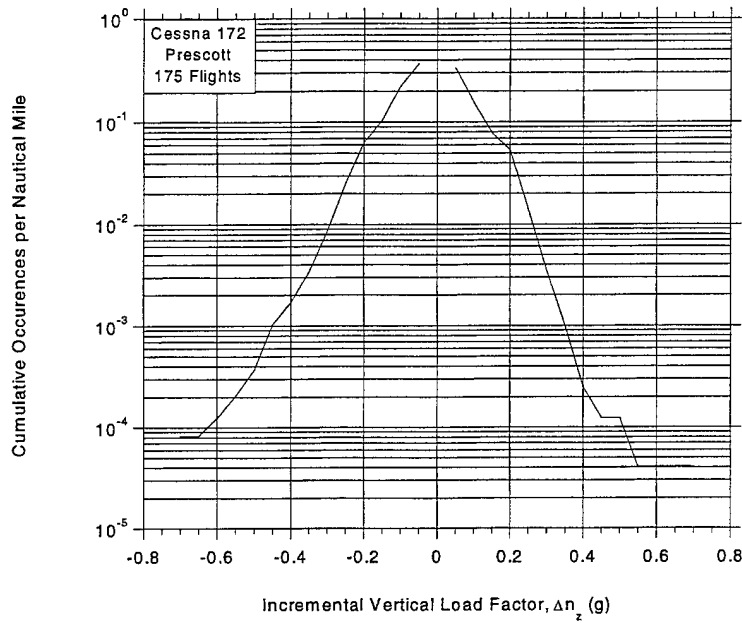

FIGURE C-37. CUMULATIVE OCCURRENCES OF INCREMENTAL MANEUVER LOAD FACTOR PER NAUTICAL MILE

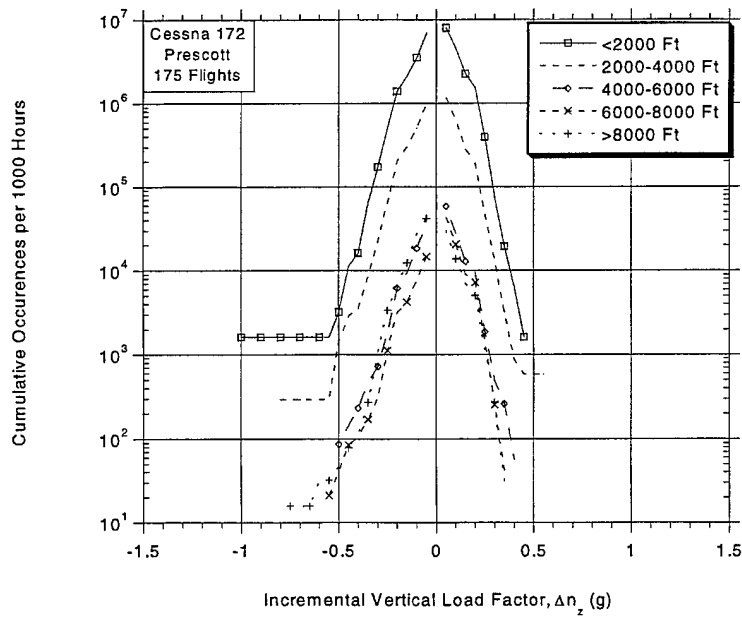

FIGURE C-38. CUMULATIVE OCCURRENCES OF INCREMENTAL LOAD FACTOR PER 1000 HOURS BY PRESSURE ALTITUDE FOR COMBINED CLIMB, CRUISE, AND DESCENT PHASES

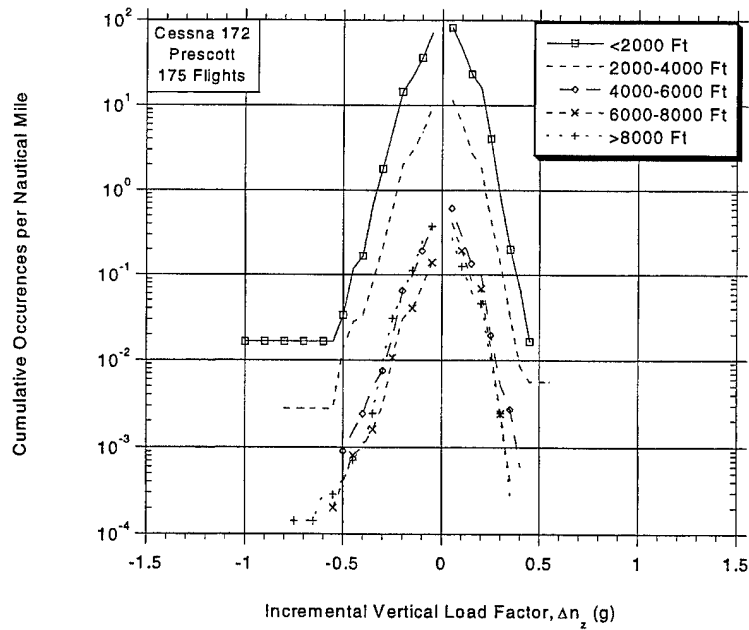

FIGURE C-39. CUMULATIVE OCCURRENCES OF INCREMENTAL LOAD FACTOR PER NAUTICAL MILE BY PRESSURE ALTITUDE FOR COMBINED CLIMB, CRUISE, AND DESCENT PHASES

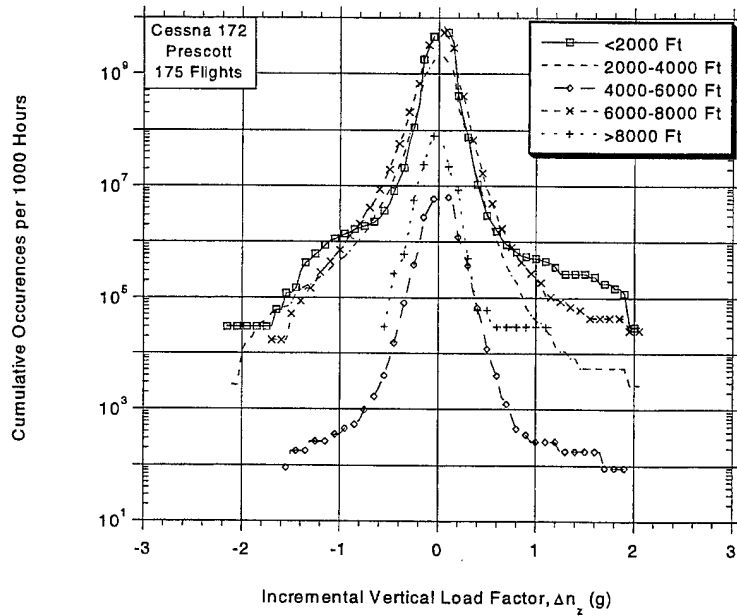

FIGURE C-40. CUMULATIVE OCCURRENCES OF INCREMENTAL LOAD FACTOR PER 1000 HOURS BY ALTITUDE ABOVE AIRPORT FOR DEPARTURE PHASE

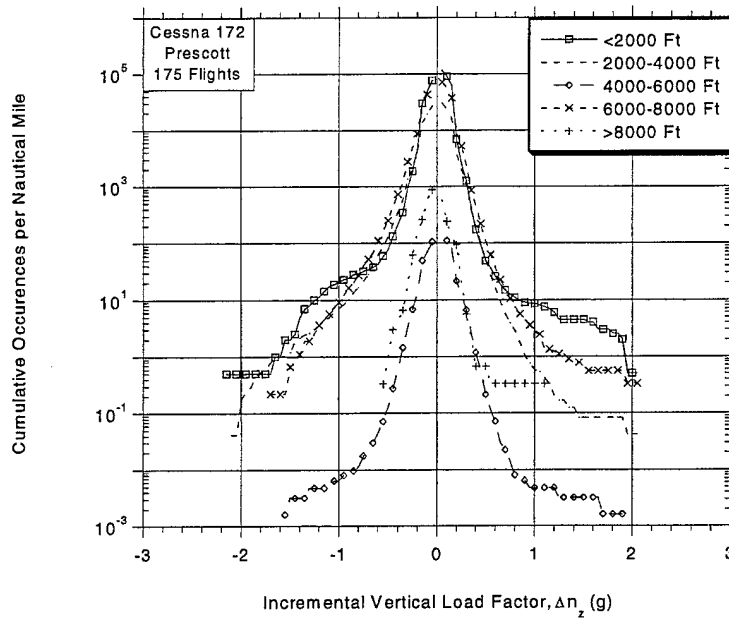

FIGURE C-41. CUMULATIVE OCCURRENCES OF INCREMENTAL LOAD FACTOR PER NAUTICAL MILE BY ALTITUDE ABOVE AIRPORT FOR DEPARTURE PHASE

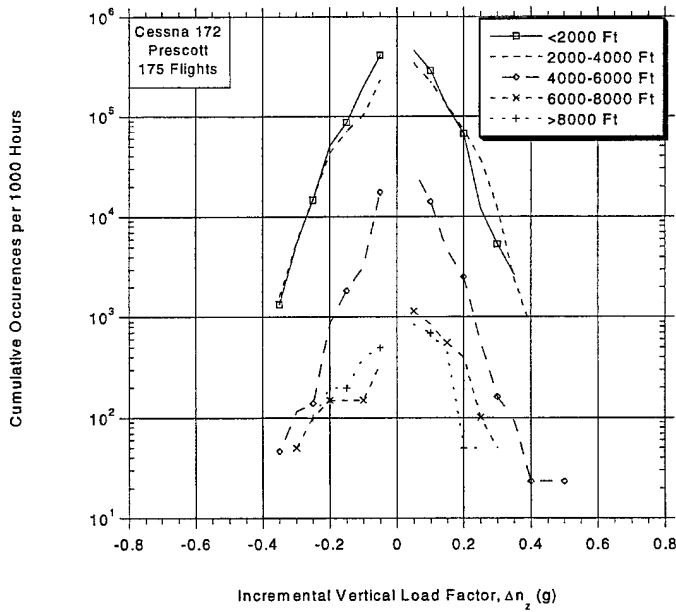

FIGURE C-42. CUMULATIVE OCCURRENCES OF INCREMENTAL LOAD FACTOR PER 1000 HOURS BY ALTITUDE ABOVE AIRPORT FOR APPROACH PHASE

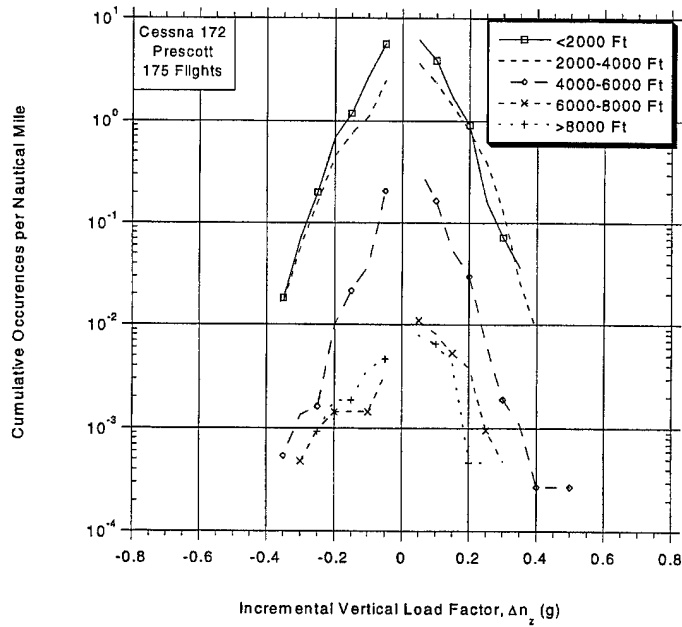

FIGURE C-43. CUMULATIVE OCCURRENCES OF INCREMENTAL LOAD FACTOR PER NAUTICAL MILE BY ALTITUDE ABOVE AIRPORT FOR APPROACH PHASE

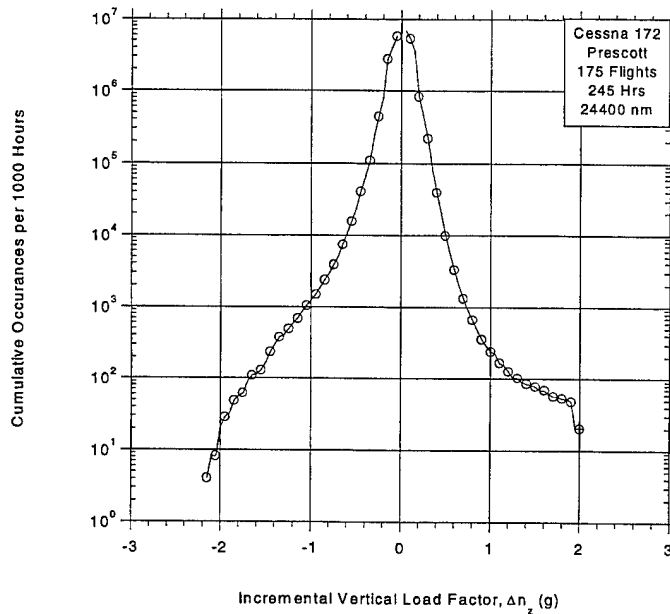

FIGURE C-44. CUMULATIVE OCCURRENCES OF INCREMENTAL LOAD FACTOR PER 1000 HOURS FOR COMBINED FLIGHT PHASES