

JPRS: 24,170

OTS: 64-31069

13 April 1964

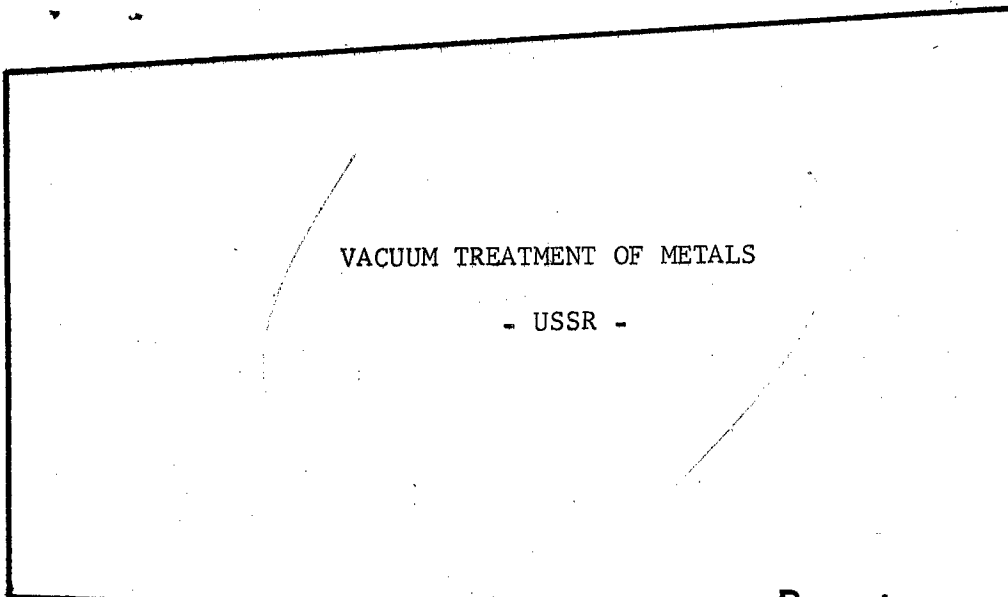

56539

VACUUM TREATMENT OF METALS

- USSR -

Reproduced From
Best Available Copy

PROPERTY OF:

U. S. DEPARTMENT OF COMMERCE

OFFICE OF TECHNICAL SERVICES

JOINT PUBLICATIONS RESEARCH SERVICE

Building T-30

Ohio Drive and Independence Avenue, S.W.
Washington 25, D. C.

DISTRIBUTION STATEMENT A
Approved for Public Release
Distribution Unlimited

Price: \$1.00

I-i

20011116 059

F O R E W O R D

This publication was prepared under contract for the Joint Publications Research Service as a translation or foreign-language research service to the various federal government departments.

The contents of this material in no way represent the policies, views or attitudes of the U. S. Government or of the parties to any distribution arrangement.

PROCUREMENT OF JPRS REPORTS

All JPRS reports may be ordered from the Office of Technical Services. Reports published prior to 1 February 1963 can be provided, for the most part, only in photocopy (xerox). Those published after 1 February 1963 will be provided in printed form.

Details on special subscription arrangements for any JPRS report will be provided upon request.

No cumulative subject index or catalog of all JPRS reports has been compiled.

All current JPRS reports are listed in the Monthly Catalog of U. S. Government Publications, available on subscription at \$4.50 per year (\$6.00 foreign), including an annual index, from the Superintendent of Documents, U. S. Government Printing Office, Washington 25, D. C.

All current JPRS scientific and technical reports are cataloged and subject-indexed in Technical Translations, published semimonthly by the Office of Technical Services, and also available on subscription (\$12.00 per year domestic, \$16.00 foreign) from the Superintendent of Documents. Semiannual indexes to Technical Translations are available at additional cost.

No

VACUUM TREATMENT OF METALS

[This document contains]

- USSR -

Following is a translation of four articles from the Russian-language book Primenenie Vakuuma v Metallurgii, (Application of Vacuum in Metallurgy), a Symposium, Publishing House of the Academy of Sciences of the USSR, Moscow, 1963. Complete bibliographic information accompanies each article.

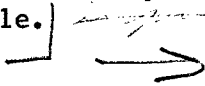

TABLE OF CONTENTS

	<u>Page</u>
Melting and Pouring of Rust-resistant Tool Steels in Vacuum Induction Furnaces.....	1
Technology of Precision Casting of Heat-resisting Alloys in Vacuum.....	10
Influence of Vacuum Melting on Properties of Steels EI-846, EI-852, EI-847, and EI-437B.....	16
Improving Heat Treatment of Magnetically Soft Alloys in a Vacuum.....	21

Handwritten scribble or signature.

MELTING AND POURING OF RUST-RESISTANT TOOL STEELS
IN VACUUM INDUCTION FURNACES

Following is a translation of an article by K. K. Chuprin, V. P. Grechin, and A. I. Drobyshev from the Russian-language book Primeneniye vakuuma v metallurgii (Application of Vacuum in Metallurgy), a Symposium, Publishing House of the Academy of Sciences of the USSR, Moscow, 1963, pages 14-21.

Steel brands VNS-1 and EI-928, alloyed with beryllium, were formerly melted in open induction ovens. By reason of the great loss of beryllium through burning and the bad deformation qualities of steel melted in air, there has been developed a new technology of melting and pouring these brands of steel in vacuum induction furnaces.

Melting of Steel

The melting and pouring of steels VNS-1 and EI-928 were conducted in the vacuum induction furnace VIAM-165 with a 2,500-hertz generator having 100-kilowatt power. A diagram of the semicontinuous vacuum furnace action is given at Fig. 1. The furnace has a melting chamber of 4 m³ separated off by gates, a degassing chamber of 2 m³, a loading chamber, a batching hopper and a chamber for changing the tip of the immersion thermocouple which measures the temperature during the melting process. Melting was conducted in a packed electrocorundum crucible of 50-kilogram capacity. Durability of crucibles came to 100-150 melts. All variants of experimental melts pursued the aim of developing a technology of melting and pouring beryllium-alloy steels in vacuum induction furnaces. There were investigated the influence of the initial charge on the properties of the steel, the behavior of the carbon in the melted metal in vacuum, the influence of the vacuum on the gas and harmful impurities content of the steel, the assimilation of the main components of the steel during melting and pouring under a 10⁻³ mm mercury column vacuum, and the possibility of using the waste from steel melted in a vacuum.

Charging procedure. Iron together with chromium (or ferrochrome), nickel and cobalt are loaded into a crucible with the furnace open stove

(on first melting) or by means of a bucket through the loading chamber (in subsequent meltings). The charging of the mixture in the crucible is done as densely as possible; the higher melting point metals should be in the middle of the crucible, i.e., in the zone of maximum temperatures. The other components are loaded through the batching hopper in the following order: carbon, vanadium, metallic beryllium (distilled) or Ni-Be alloy -- for steel of brand VNS-1; carbon, titanium and beryllium -- for steel of brand EI-928.

Creation of vacuum. Upon closing the furnace, the fore pump VN-6 and simultaneously current to 20-30 o/o of the power of the generator are switched on. After evacuation by means of the fore pump to a residual pressure of $1 \cdot 10^{-1} - 3 \cdot 10^{-1}$ mm mercury column booster pump BN-4500 is connected in.

After this the furnace is switched on to full power. Melting of charge is carried out at a forced pace to avoid the formation of bridges. It is desirable to conduct the process of melting the charge in vacuum having a residual pressure of $1 \cdot 10^{-3}$ mm mercury column. When there is a large content of oxygen in the charge (for example, in Sulinsk iron or armco iron), toward the end of the melting there commences a vigorous boiling of the melt that brings about ejections of metal from the crucible. In this case the current is turned off, pumps are disconnected, helium or argon is introduced, and melting is finished under neutral gas with residual pressure of 60-80 mm mercury column. After melting under neutral gas the metallic bath is again subjected to vacuum for the course of 15-20 minutes at a vacuum of $1 \cdot 10^{-3}$ mm mercury column.

In a VIAM-165 furnace a pressure of 0.1 mm mercury column is attained after 10-15 minutes, and when the booster pump is switched on, after 3-5 minutes a pressure of 10^{-3} mm mercury column is set up.

Reduction and introduction of alloying additives. After complete melting and degassing of the metallic bath the metal is heated to 1,580-1,600 and carbon in the form of graphite powder is introduced through the batching hopper for reduction of the metallic bath [See Note] and for alloying of the steel. Depending upon the quantity of introduced carbon, in 2-5 minutes after its assimilation there were introduced ferrovanadium and Ni-Be alloy or metallic beryllium. At the moment of introduction of the beryllium the temperature of the metallic bath should not exceed 1,500°. In alloying steels of brands VNS-1 and EI-928 the introduction of a subsequent additive, as a rule, takes place after melting and assimilation by the bath of the preceding additive, for which 5 minutes are usually required. The melt is released 5-7 minutes after addition of the beryllium.

([Note] Manganese, silicon, aluminum and other deoxidizing agents were not used.)

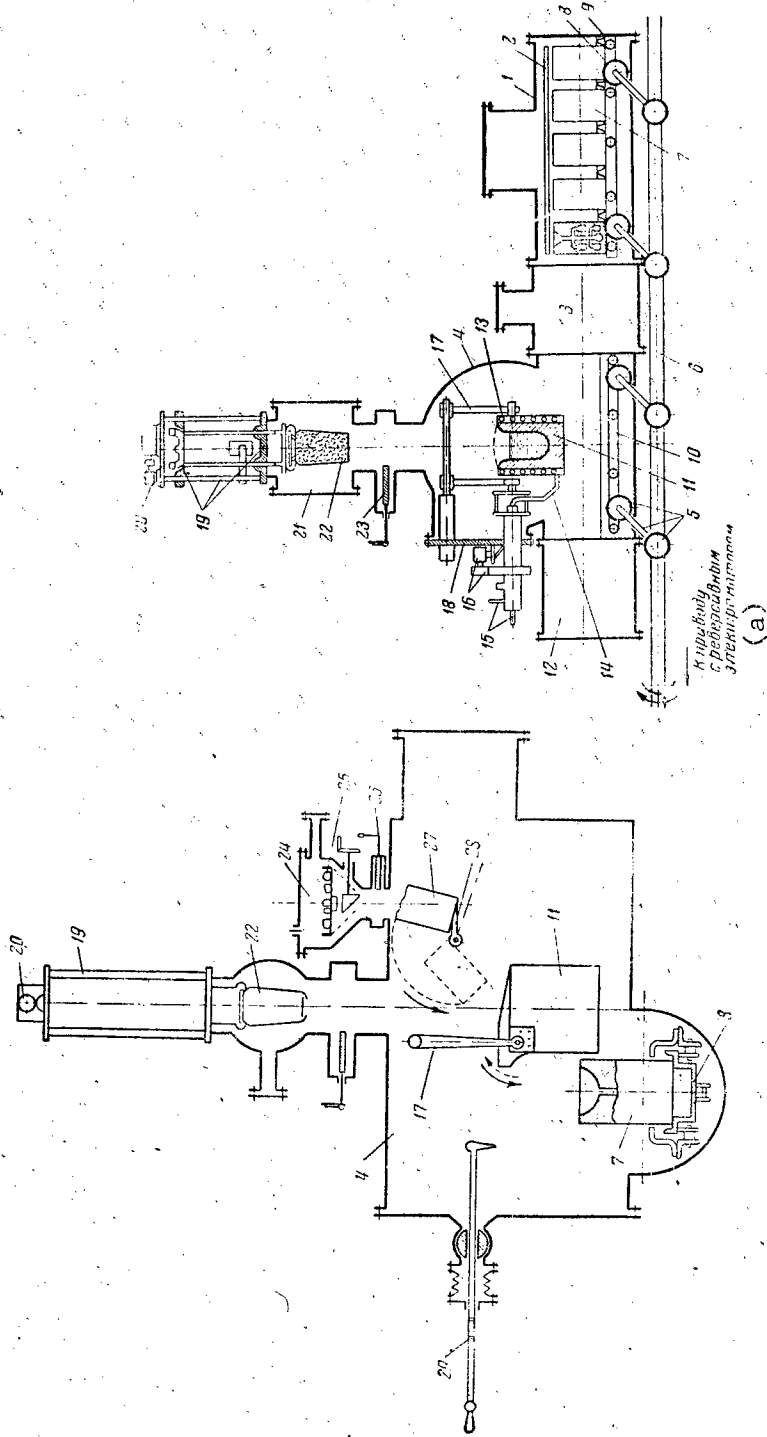

Fig. 1. Diagram of semicontinuous-action vacuum induction furnace VIAM-165.

- a) To drive with reversible electric motor; 1) chamber for preliminary degassing of molds; 2) electric heater; 3) sluice; 4) melting chamber; 5) mechanism for shifting platforms; 6) drive shaft for shifting mechanism; 7) molds; 8) platform; 9) rollers; 10) roll trams; 11) crucible; 12) dead-end channel; 13) inductor; 14) power communications; 15) cooling communication; 16) turning mechanism; 17) bracket; 18) door; 19) loading mechanism; 20) drive; 21) door of chamber; 22) container with charge; 23) slide valve; 24) batching hopper; 25) charge; 26) sluice; 27) turn-over hopper; 28) axle; 29) mixer.

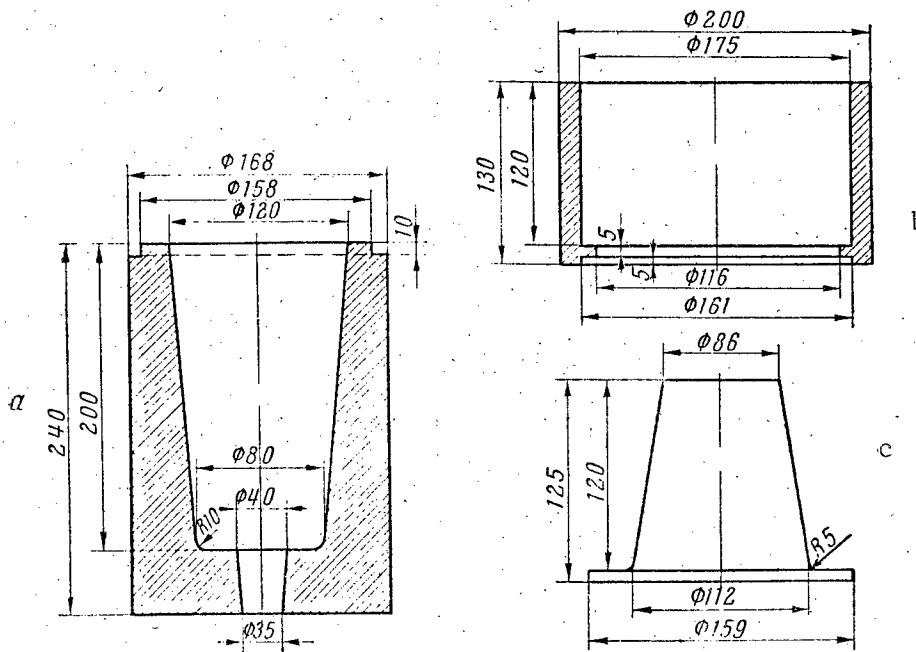

Fig. 2. Casting mold (a), extension (b) and patterns (c) for casting of ingots weighing 17 and 25 kilograms.

Pouring of steel. In order to preserve the advantages of vacuum melting the pouring of metal also takes place in vacuum. Experimental melts were poured into cast-iron casting molds (Fig. 2). The re-packed extensions and funnels were heated 2-3 hours at $950-1,000^{\circ}$ before their use. If heated extensions stood in air more than 3 hours after heating, then before they were poured they were heated together with the casting molds to $500-600^{\circ}$, cooling in air below $60-70^{\circ}$ not being permitted.

Before assembly, extension and funnel are well cleaned and thoroughly ventilated with dry compressed air. The casting molds are thoroughly cleaned with a metallic brush on all internal surfaces and ventilated with dry compressed air. Before being put into the de-gassing chamber the casting molds with their extensions are once more finally ventilated with dry air.

After heating of the metal in the crucible to $1,540-1,570^{\circ}$ (for steel of brand VNS-1) or $1,450-1,470^{\circ}$ (for steel of brand EI-928) the melt is poured out through funnels in ingots or shaped castings. The bottom and riser part of the ingot are poured as slowly as possible. The casting molds are put on the working platform 15-20 minutes after pouring and the ingots are stripped.

Pouring is carried out with pumps operating.

Results of Investigation

Assimilation of beryllium by the melted bath of metal in vacuum comes to 90-95 o/o, no matter what the form of the beryllium additive; upon melting in an open induction furnace 65-70 o/o of beryllium is assimilated.

Ni-Be alloy may be recommended, since it melts faster than metallic beryllium. Assimilation of beryllium depends on the oxygen content in the metallic charge. From the data presented in Fig. 3, it follows that to increase assimilation of beryllium it is necessary to use iron having a minimum oxygen content.

When there is a good vacuum seal of furnace, carbon monoxide serves as a proof of its reducing ability. There has been established a direct proportion between the reduction potential of carbon and the degree to which the metallic bath is heated.

From the data presented in Fig. 4, it follows that carbon interacts weakly with oxides of the metal in vacuum at 1,500° and acts 3-4 times more actively as a reducing agent at 1,600°. In experiment [1] it was established that at 1,600° in vacuum with duration of 10 minutes, metal practically does not interact with the electrocorundum crucible.

When melting in vacuum, for fuller reduction of steel by means of carbon one should before addition of carbon heat the metallic bath to 1,600°.

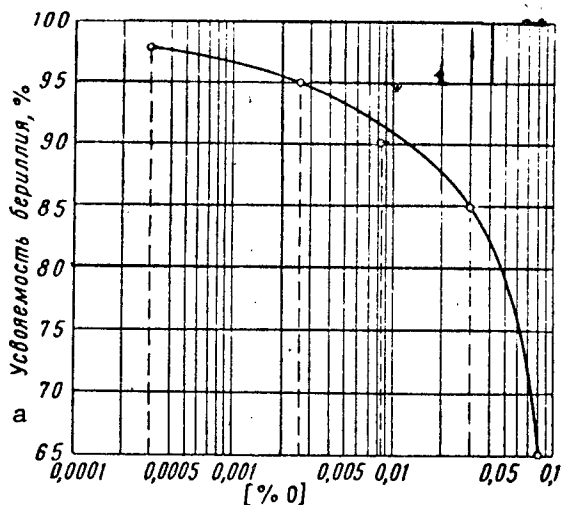

Fig. 3. Influence of vacuum on assimilation of beryllium (from nickel-beryllium alloy) relative to content of oxygen in charge.
a) Assimilability of beryllium, in %.

Mean values for the degree of assimilation of chromium, nickel, tungsten and cobalt exceed 99 o/o, and for vanadium 92 o/o, therefore upon calculation of charge it is necessary to take assimilation of vanadium as 90 o/o, and chromium, nickel, tungsten and cobalt as 100 o/o.

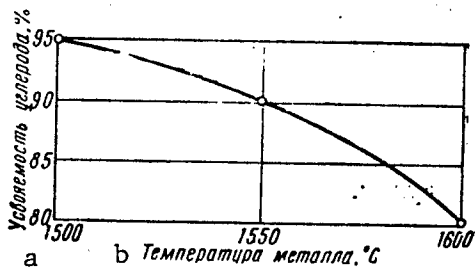

Fig. 4. Influence of temperature on assimilation of carbon of liquid bath in vacuum. a) Assimilability of carbon, in %; b) Temperature of metal, degrees C.

Quality of charge materials. The properties of steels melted with the use of ferrochrome are in no wise different from those melted from metallic chromium. Results of tests of vacuum meltings, conducted with the addition of 50 o/o vacuumed wastes, and meltings from 100 o/o fresh charge materials were identical.

The influence of vacuum on gas content in steel. Gas content in vacuum and usual steels is shown in Fig. 5. As can be seen, melting in vacuum with residual pressure of 10^{-3} mm mercury column lowers oxygen content by 4-5 times, hydrogen by 6-7 times, nitrogen by 1.5-2 times.

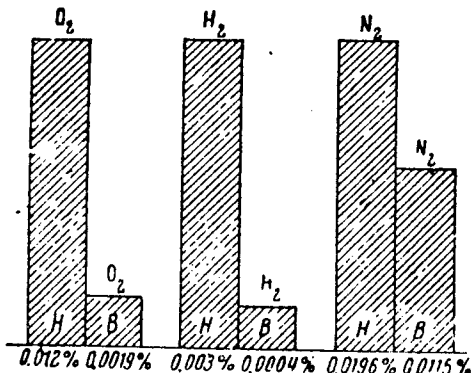

Fig. 5. Influence of vacuum on gas content in beryllium steels (N -- non-vacuum metal, V -- vacuum metal).

Influence of vacuum on content of harmful impurities in steel. Results of analyses of harmful impurities in vacuum and usual metals are shown in Fig. 6. From these data it follows that after melts in a vacuum of 10^{-3} mm mercury column the quantity of impurities, especially bismuth, arsenic, lead, and tin, is lowered significantly.

Such lowering of harmful impurities and gases upon melting in a vacuum steels of brands VNS-1 and EI-928 increases their corrosional stability and resistance to wear.

Properties of steel melted in vacuum. The macrostructure of poured steel in a longitudinal axial section of a cylindrical ingot is shown in Fig. 7. The practice of the "Elektrostal" factory has shown that brand EI-928 type is significantly denser upon casting in square ingots, but vacuum steel proves to be dense enough in cylindrical ingots as well, both on the periphery and at the center of the ingot. Almost all sections are

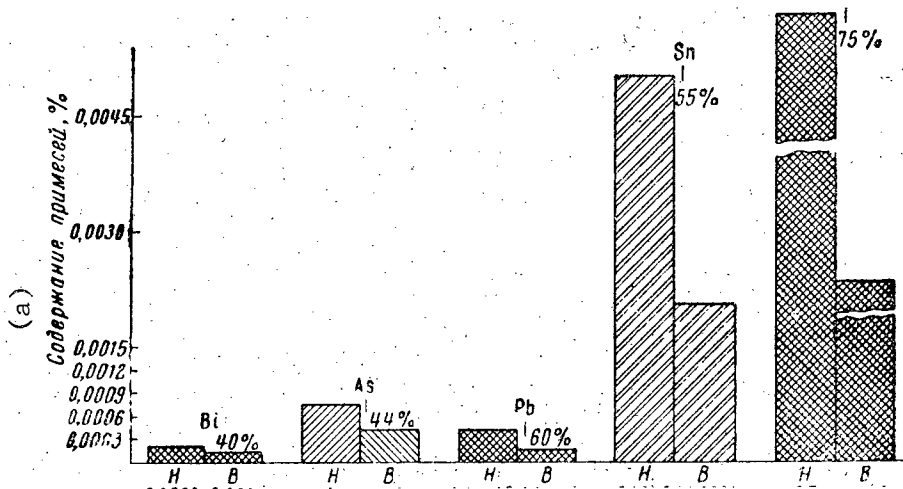

Fig. 6. Influence of vacuum on content of harmful impurities in beryllium steels (N -- non-vacuum metal, V -- vacuum metal).

a) Impurities content, %.

occupied by a columnar macrostructure, since the absence of impurities does not hinder free growth of crystals. Steel of brand EI-928 shows deep open shrinkage upon crystallization of the ingot, but upon pouring in vacuum its surface is not oxidized and is sealed upon rolling.

The low plastic properties of EI-928 steel, melted in open induction furnaces, give rise to its bad deformation characteristics where the content of beryllium and carbon is more than 1 o/o, whereas vacuum steel of the same composition is deformed successfully. The higher plastic properties of vacuum steels are characterized by the following data (after quenching in water from a temperature of 1,000°):

Steel		EI-928	VNS-1
Plastic properties upon pouring:			
δ, %	in vacuum	3	9
	usual	1	8
ψ, %	in vacuum	3	27
	usual	0.5	10

Conclusions

1. Upon melting and pouring of steel of brands VNS-1 and EI-928 in vacuum induction furnaces with vacuum up to $1 \cdot 10^{-3}$ mm mercury column chromium, nickel, tungsten and cobalt are assimilated 100 o/o, vanadium 90 o/o; beryllium is assimilated 95 o/o (upon introduction either of

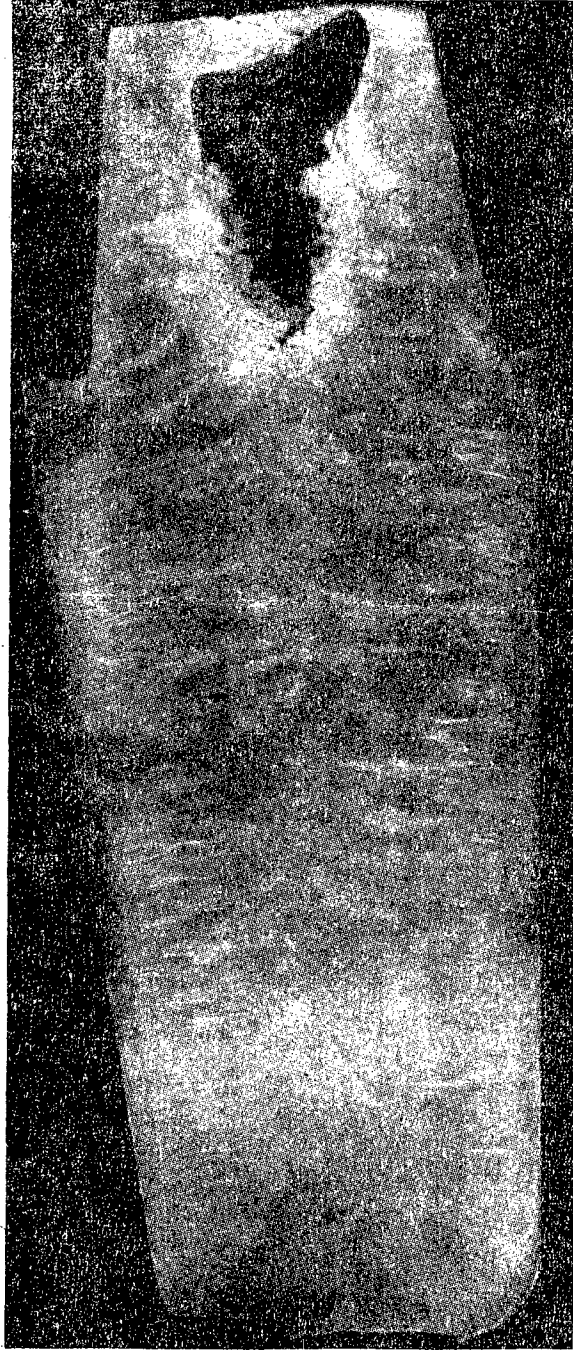

Fig. 7. Macrostructure of longitudinal section of cylindrical ingot weighing 25 kilograms.

Ni-Be alloy, or of metallic beryllium) with a content of oxygen in the initial iron not higher than 0.005 o/o. Carbon is assimilated 80 o/o at a 1,600° temperature of the metallic bath.

2. The use of vacuumed ferrochrome instead of metallic chromium for alloying of vacuum steel does not affect the properties of the steel. In the charge it is possible to use 50 o/o vacuum melt wastes.

3. After melting and pouring steel of brands VNS-1 and EI-928 in vacuum induction furnaces the gas content decreases as compared with the content thereof in usual steels: oxygen by 4-5 times, hydrogen by 6-7 times, and nitrogen by 1.5-2 times. The impurities content of bismuth is lowered by 40 o/o, arsenic by 45 o/o, lead by 60 o/o, tin by 55 o/o and copper by 75 o/o.

4. Steel of brands VNS-1 and EI-928, melted and poured in a vacuum, possesses higher plastic properties.

There have been drawn up instructions on industrial sanitation (jointly with the Institute of Work Hygiene and Occupational Diseases of the Academy of Medical Sciences of the USSR) for production and processing of steels and alloys with content of beryllium up to 2.5 o/o.

Literature

1. K. Diels, Vakuuntechnische Probleme in der Metallurgie [Problems of Vacuum Technics in Metallurgy], Berg- und Huttenmannische Monatshefte, Heft 7/8, 1955.
2. O. Winnler, Die Entwicklung der Induktionsbeheizten Hochvakuum-Schmelzanlagen [Development of Induction-heated High-vacuum Fusion Installation], Berg- und Huttenmannische Monatshefte, Heft 7/8, 1955.
3. B. V. Linchevskiy, V. I. Kashin, Laboratory High-vacuum Induction Furnace, All-Union Institute of Scientific and Technical Information, Moscow, 1958.
4. A. V. Emyashev, On the Technology of Vacuum Fusion of Metals and Alloys, Symposium, "Application of Vacuum in Metallurgy," Publishing House of the Academy of Sciences of the USSR, 1958.

5463
CSO: 1879-D

TECHNOLOGY OF PRECISION CASTING OF HEAT-RESISTING ALLOYS IN VACUUM

[vacuum casting] HS
Following is a translation of an article by N. D. Potashnikov from the Russian-language book Primeneniye vakuuma v metallurgii (Application of Vacuum in Metallurgy), a Symposium, Publishing House of the Academy of Sciences of the USSR, Moscow, 1963, pages 22-26.]

The performance of investment pattern casting in heat-resisting alloys containing such chemically active elements as aluminum or titanium, is associated with major difficulties by reason of the nature of the actual alloy, which is inclined to form oxide blisters. For this reason rejects of castings on account of blisters came to 60 o/o and more, and the utilization factor for the metal came on the average to 10-20 o/o, inasmuch as use of return metal in the charge was allowed to the extent of not more than 50 o/o.

A group of authors, with the participation of workers of the Scientific Research Institute for Iron and Steel Metallurgy, designed high-frequency vacuum apparatus for casting of turbine blades from heat-resisting alloys adaptable to conditions of series production, and also developed a technological process for accurate casting in vacuum which ensures the production of quality castings without the presence of oxide blisters.

Through experiments specially set up there was established the possibility of reduction of metal oxides by means of carbon where the melted metal is kept under lowered pressure within a definite range of temperatures. The reaction of reduction of oxides is accompanied by the separating out of dark bubbles of carbon monoxide. Separation out of such bubbles stops after disappearance of the oxide blister and after complete clearing up of the metal surface which bears witness to a restoration of the oxides by the carbon. Reduction of oxides is accompanied by a sharp decrease of the concentration of carbon during the process of vacuuming the melt. Thus the quantity of carbon in the vacuumed melt decreases to 10-20 o/o of its content in the initial charge. Carbon

monoxide comes to 30 o/o in melting of strongly oxidized waste and 10 o/o in melting of a normal charge.

Construction of the Induction Vacuum Installation

The installation consists of a mobile chamber and a foundation (Fig. 1).

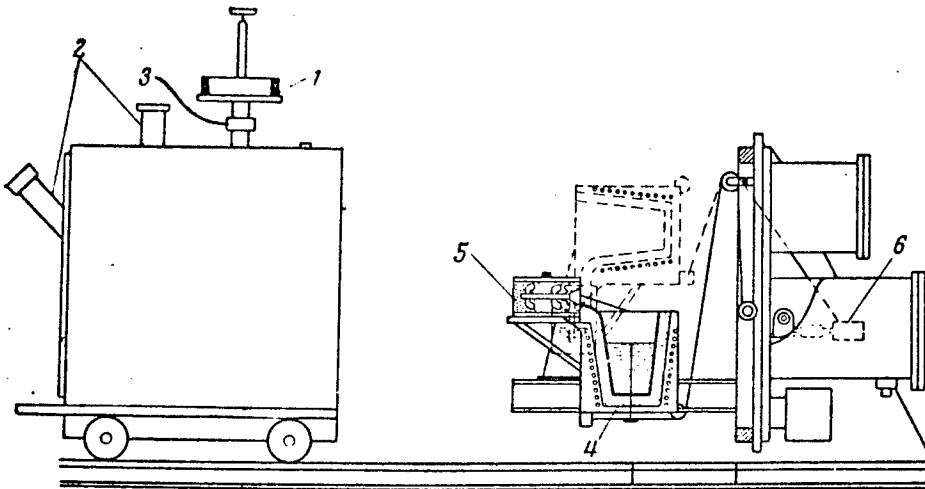

Fig. 1. Vacuum induction furnace of 16-kilogram capacity.

The mobile chamber consists of a rolling water-cooled housing with batching hopper 1 and inspection windows 2. The purpose of the hopper is to introduce additives into the bath without disturbing the vacuum in the chamber. In the hopper are six compartments for storage of various additives. On the housing there is also mounted a radiation pyrometer, 3, for measurement of the temperature of the metal.

On the foundation of the furnace there is fixed a tilting induction melting furnace, 4, with flask, 5, and drive, 6. All important parts of the foundation are cooled by water. The mechanical drive for tilting the furnace is in a separate housing (inside the base of the furnace) and consists of a worm reducing gear connected with a direct current motor, which permits a range of crucible tilting speeds from 12 to 20 seconds. Tilting is carried out by means of a nickel-chromium cable which winds onto drum. To ensure safety of tilting terminal switches are installed. The source of energy for feed of the inductor is a generator of 100-kilowatt power and 2,500-hertz frequency. The voltage produced by the inductor is 1,000 volts.

A pressure of $3 \cdot 10^{-1}$ mercury column is created by fore pumps VN-4 or VN-6. In order to obtain lower vacuum a booster pump BN-1500 is fitted.

On the vacuum duct before the fore pumps (Fig. 2) there are fixed chillers, which consist of a receptacle containing two cylinders with a coil. The interior cylinder is filled with liquid oxygen or nitrogen; the air pumped out passes into the space between the two cylinders; hereupon the vapors which are present are frozen. For cooling the chillers acetone in mixture with solid carbon dioxide is also used.

The installation has filters for catching dust upon the pumping out of air from the furnace.

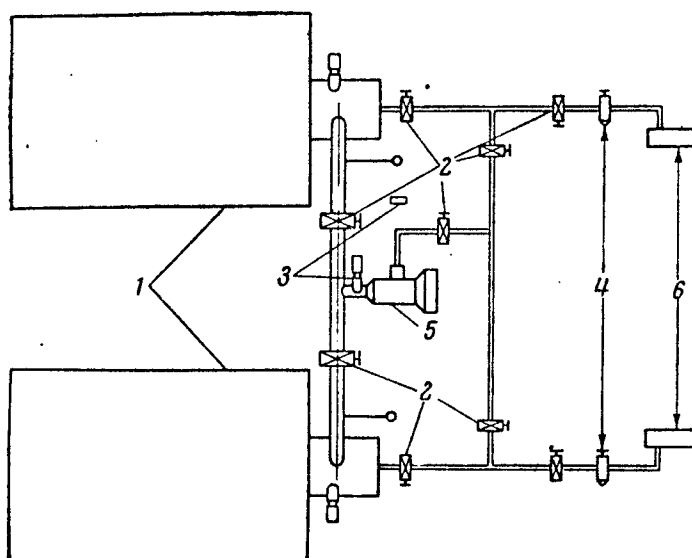

Fig. 2. Diagram of the vacuum system of the installation.
 1) Vacuum furnace; 2) gate valve; 3) vacuum gage;
 4) chiller; 5) booster pump; 6) vacuum pump VN-4.

Technological Peculiarities of Melting and Pouring in a Vacuum

The refractory materials and the technology of filling and burning off the crucible of the furnace. Refractory materials used during open melting, and the technology of lining the crucible, are completely unsuitable in melting under vacuum conditions. A crucible working under vacuum conditions must meet requirements besides the heat resistance, the sufficient fireproof quality, the chemical inertness, necessary in open melting, which are imposed by the simultaneous action of vacuum and high temperature.

The material of the crucible must not interact with metal, otherwise this will lead to contamination of the metal. The lining of crucible must be tight, and the internal surface glazed. Crumbling of the material of the crucible is not permissible in the closed process of melting and pouring where cleaning the surface of the metal is awkward. If the conditions listed are not fulfilled, there occurs contamination of castings through non-metallic inclusions.

There is selected a fire-resistant material satisfying these conditions -- white electrocorundum of EB-99 brand (All-Union Government Standard 3647-47).

The lining is prepared by thoroughly mixing (dry-run) the following fractions of electrocorundum: 70 o/o in granularity No 24-32, 25 o/o in granularity No 80-120 and 5 o/o in granularity No 200-300; furthermore, there is mixed in boric acid in a quantity of 1.5-2 o/o of the weight of the mixture. On the bottom of the crucible prepared from the lining mass there is created a graphite (electrode) pattern in the inductor and there is sprinkled in a dry mixture of electrocorundum of the fractions specified. After ramming of the lining mass and the finishing of the slopes and the pouring lip the furnace is closed and the graphite pattern is heated to 2,100°. Hereupon the fireproof mass is fused and a glazed internal surface of crucible is obtained.

A crucible prepared by this method sustains up to 300 melts.

Making use of the installation. After creation of a vacuum in the system and adjustment of the furnace to the melting crucible there is loaded a charge calculated to fill one mold. Upon completion of charging the current is switched on and on the platform of the furnace there is set a mold heated to 900°; it is fastened by means of a throw-over cleat, then the chamber is rolled to the foundation of the furnace (the motionless part) and it is connected to the vacuum system. Hereupon, thanks to the creation of rarefaction, the chamber is tightly pressed to a rubber obturator ring in the motionless cover. Melting of metal and vacuuming are carried out simultaneously.

After melting of the metal the mirror surface of bath is covered with oxide blisters. In proportion to increase of temperature of the liquid bath the oxide blisters gradually disappear, which is connected with the reduction of oxides in the vacuum. Upon further holding of the metal in the vacuum the ring of oxide blisters decreases and at last completely disappears, a pure mirror surface of liquid metal remaining. Metal is considered well vacuumed, when upon turning off the furnace blisters do not appear on the mirror of the melted metal.

After the mirror surface of the metal is cleansed of blisters, the temperature of the metal is brought to 1,630-1,650° on the ardometer and pouring into the mold is carried out. Upon completion of pouring the gate valve between chamber and vacuum system is closed and the valve connecting the chamber with the atmosphere is opened. Then the chamber is rolled away, the molds are removed, the crucible is cleansed of remnants from the preceding melt, and after ventilation with compressed air the furnace is set in vertical position for the following melt. Duration of melt comes to 1 kg/min; time of vacuuming is 10-12 minutes.

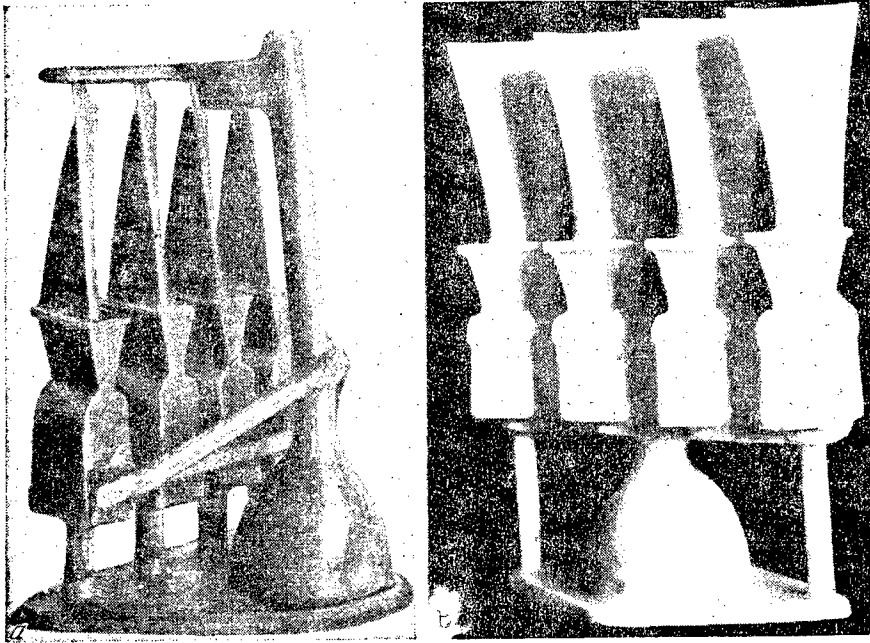

Fig. 3. Flow gate system in casting in air (a) and in vacuum (b).

Method of casting. In casting in vacuum the need for complicated flow gate systems disappears; their purpose was to take up oxides and to ensure undisturbed filling of the mold without turbulence or spouting, and with minimum oxidation of the stream of metal. Upon casting in vacuum the flow gate takes on especially important significance in ensuring the direction of crystallization (Fig. 3).

A flow gate system for filling the mold from above with the edge of the mold up against the furnace is considered to satisfy these requirements; the mold is set horizontally to the placement of the axis of flow gate movement (the riser) at an angle of 90° to the axis of the melting crucible. This method of filling ensures minimum motion of metal from furnace to mold. The stream of metal does not erode the mold in view of the constancy of the trajectory of the motion of metal and the careful centering of the pouring basin with reference to the lip of the melting crucible.

In the process of cooling a casting in vacuum there frequently appears at various points friability which is occasioned by insufficient metallostatic pressure. Compensating metallostatic pressure by increasing airholes was not successful in all cases; furthermore, this course leads to increased expenditure of liquid metal.

A method of obtaining a suitable casting was found in a combination of pouring in vacuum with crystallization under conditions of atmospheric pressure. With this aim the chamber of the vacuum installation is fitted

with a valve for fast supplying of air after filling the mold is finished, and prior to the beginning of crystallization.

Conclusions

1. The new technology of precision casting of heat-resistant alloys in vacuum afforded a possibility of eliminating defects and reject castings on account of oxide blisters which had come to 60 o/o and more.

In melting and casting in vacuum, carbon monoxide and irrevocable losses decrease significantly. Return metal is more completely used, since its use in the charge as though it were fresh material is permitted (in open melting there is used in the charge no more than 50 o/o of return metal).

2. There have been designed, manufactured, and introduced into exploitation high-frequency vacuum furnaces for melting and pouring of heat-resistant alloys applicable to series conditions of production.

5463
CSC: 1879-D

INFLUENCE OF VACUUM MELTING ON PROPERTIES
OF STEELS EI-846, EI-852, EI-847, and EI-437B

Following is a translation of an article by V. M. Amnenko, I. S. Bolgov, M. P. Zeydlits, V. M. Azhazha from the Russian-language book Primeneniye vakuuma v metallurgi (Application of Vacuum in Metallurgy), a Symposium, Publishing House of the Academy of Sciences of the USSR, Moscow, 1963, pages 61-64.

The contemporary development of technology imposes extraordinarily high demands upon materials working at high temperatures. In many cases, aside from high heat resistance materials have to possess good plasticity and must not create difficulties during their treatment. Especially important is an optimum combination of these properties during manufacture of thin-walled articles which are to work at high temperatures.

From native and foreign practice it is known that heat-resisting steels and alloys, prepared under vacuum conditions possess a number of advantages as compared with those melted in open furnaces. Their mechanical and physicochemical properties both at room temperatures and at high temperatures are improved [1, 2].

Steels EI-846, EI-847, EI-852 and alloy EI-437B, melted in open furnaces, contain a significant quantity of non-metallic inclusions, which markedly hamper the technology of manufacture of thin-walled articles and can become a cause of premature breakdown of these details.

Naturally the study of the properties of the materials indicated after their being melted in vacuum is of significant scientific and practical interest.

Equipment and Technology of Melting

Steel was melted in an induction vacuum furnace with a machine generator having 100 kilowatts power and capacity of crucible 20-25 kilograms.

Construction of the furnace made it possible to maintain a vacuum in the process of melting coming to $1 \cdot 10^{-4} - 5 \cdot 10^{-5}$ mm mercury column, and to carry out measurement of temperatures, taking of test samples, loading of charge, deoxidation and alloying with various additives during the process of melting. The melted metal could be poured into one or several casting molds. Melting was carried out in crucibles of pure aluminum oxide. The working surface of the crucibles was fused [3].

For melting of steels and alloy in vacuum the following charge materials were used: Armco iron, nickel of brand NO, alumothermal chromium X-1, molybdenum in rods, aluminum A-000, sponge titanium, metallic silicon, Fe-Mn and Ni-B alloys, spectrally pure carbon. Armco iron, nickel and chromium were loaded into the crucible immediately, and the remaining components of the melt were placed in the batching hopper. After production of a vacuum the metal was melted and was held for 10-15 minutes, then deoxidation of the melt by means of carbon was carried out and the remaining alloying elements were introduced in the order usual for all steels. The introduction of big additions was carried out in 4-6 minutes, that of small ones in 2-3 minutes. Metal was poured into casting molds in 8-10 minutes after introduction of all alloying additions, at a temperature 100-120 higher than the melting point of the alloy in question. The ingots secured, weighing 5-12 kilograms, were forged by steam hammer a diameter of 40-100 mm into rods of 18-20 mm.

After heat treatment of the materials indicated, samples for tests were prepared from them.

Results of Investigations

Steel EI-846. High-quality melting of this steel in an open furnace encounters a number of difficulties. The steel should have a very low content of carbon -- 0.02-0.03 o/o; such a carbon content, especially at the lower limit, is very difficult to secure due to the elevated content thereof in the charge materials. But this condition can easily be met when melting this steel under vacuum.

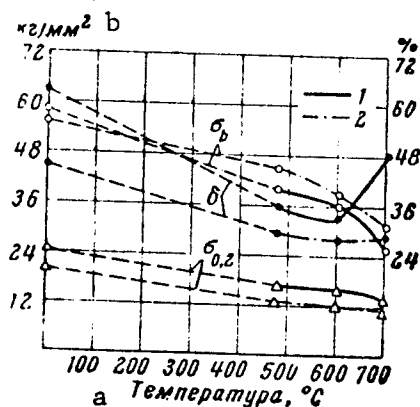

Fig. 1. Properties of steel EI-846 with 0.1 o/o of boron. Melting: Line 1 -- in vacuum; line 2 -- in air. a) Temperature, degrees C; b) kg/mm².

The steel has a high content of boron -- 0.1-0.8 o/o. In melting steel in air with content of boron nearer to the lower limit it is still possible to ensure sufficient plasticity of material, but with high content of boron plasticity of steel is sharply lowered. The most radical means to increase plasticity of high-boron steels is to melt them under vacuum.

In Fig. 1 there are set forth the mechanical properties of steel EI-846 with 0.1 o/o tungsten, melted under vacuum and in air. As can be seen, the limits for the strength and the fluidity of both meltings are approximately alike, but the relative stretch for steel melted under vacuum, rose at room temperature by 50 o/o, at high temperatures by almost twice. Impact ductility increases sharply: steel, melted in air, has $a_k = 9.5 \text{ kgm/cm}^2$, and that prepared under vacuum has $a_k = 20.5 \text{ kgm/cm}^2$.

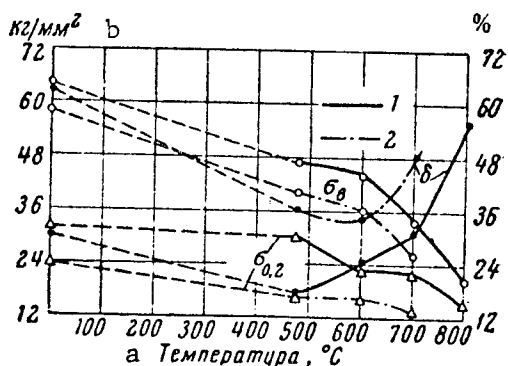

Fig. 2. Properties of steel EI-846, melted in vacuum: line 1 -- with 0.1 o/o tungsten; line 2 -- with 0.8 o/o tungsten.
a) Temperature, degrees C;
b) kg/mm².

In Fig. 2 there are indicated mechanical properties under short-duration fracture depending upon temperature of testing steels with boron content of 0.1 and 0.8 o/o. Results of tests show that increase of content of boron in vacuum steels increases ultimate strength and yield point, but the relative stretch of such a steel is significantly lower than with steel with 0.1 o/o tungsten; but still stretch remains sufficiently high. Impact ductility of an alloy with 0.8 o/o tungsten is equal to 4.5 kgm/cm². Melted under vacuum, this same steel with even higher content of boron (1.15 o/o) had approximately the same plastic characteristics as steel with 0.8 o/o tungsten, but higher figures for ultimate strength and yield stress. The investigations conducted showed that boron is evenly distributed all along the ingot.

Steel EI-852. In Fig. 3 there are set forth the mechanical properties under short-duration fracture depending upon temperature of testing steel melted in air and under vacuum. On melting under vacuum ultimate strength and yield stress are strongly lowered; relative stretch is increased approximately by 2 times at high temperatures. Impact ductility remains the same.

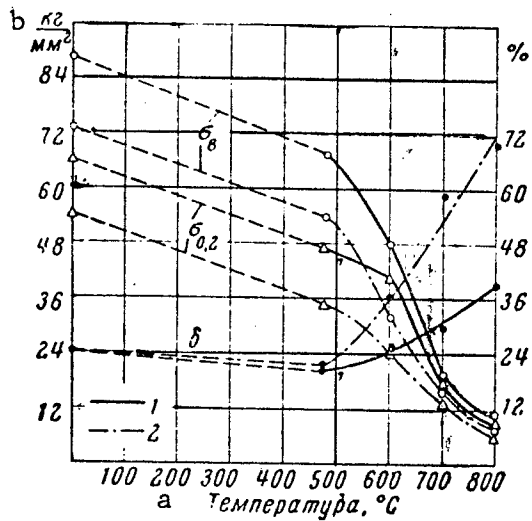

Fig. 3. Properties of steel EI-852. Melting: line 1 -- in air; line 2 -- in vacuum. a) Temperature, degrees C; b) kg/mm².

Steel EI-847. This heat-resistant steel, after being poured under vacuum improved almost all its mechanical properties. As can be seen from the data presented in Fig. 4, ultimate strength and yield stress rose insignificantly; relative stretch was improved, especially at high temperatures. Impact ductility of material melted under vacuum was $a_k = 22 \text{ kgm/cm}^2$, and in air $a_k = 15 \text{ kgm/cm}^2$.

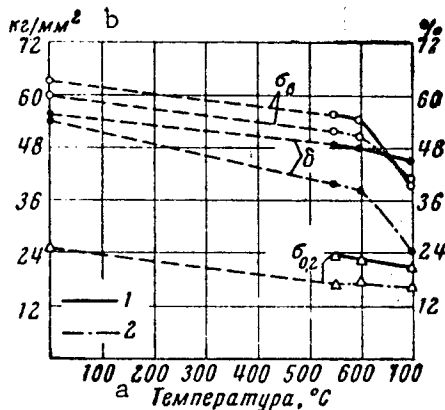

Fig. 4. Properties of steel EI-847. Melting: line 1 -- in vacuum; line 2 -- in air. a) Temperature, degrees C; b) kg/mm².

Alloy EI-437B. This heat-resistant alloy, melted under vacuum, possesses increased plasticity over the entire range of temperatures. Impact ductility is 16-18 kgm/cm². Below (see table) there are set forth the results of tests of the alloy, melted under vacuum and in air.

The level of heat resistance of alloy EI-437B does not diverge from what the literature says. For all steels, melted under vacuum, hardness was approximately 10-20 o/o lower, than for steels melted in an open furnace.

In all steels, melted under vacuum, the number of non-metallic inclusions was considerably lower, and their size did not exceed one point. The gases content of the alloy melted under vacuum was 5-10 times lower than in steels melted in air, and came to: oxygen $7 \cdot 10^{-4} - 2 \cdot 10^{-3}$ o/o, hydrogen $1 \cdot 10^{-4} - 3 \cdot 10^{-4}$ o/o, nitrogen $1 \cdot 10^{-3} - 3 \cdot 10^{-3}$ o/o.

Mechanical Properties of Alloy EI-437B

Temperature, °C	σ_D , kg/mm ²		σ_S , kg/mm ²		δ , %	
	Air	Vacuum	Air	Vacuum	Air	Vacuum
25	96	109	66.5	63.7	14.0	31.2
600	94	92.5	59.0	57.4	22.0	32
700	84	85.6	56.5	56.0	16.5	23.8
800	56	60.5	44	48	16	13
900	--	30	--	25.3	--	16

Conclusions

In melting steels under vacuum plastic properties considerably increase and other characteristics of the metal are improved. Quantity and dimensions of nonmetallic inclusions are lowered, content of gases decreases significantly.

Literature

1. L. D. Codd, "Steel," 1955, 137, 7, 136.
2. J. Moore, "Iron Age," 1953, 171, 14, 154.
3. A. V. Emyashev, Symposium, "Application of Vacuum in Metallurgy," Publishing House of Academy of Sciences of USSR, 1958, page 54.
4. D. E. Livshits, Symposium, "Research on Heat-Resistant Steels," Publishing House of the Academy of Sciences of the USSR, 1957, Vol. IX, page 26.

5463

CSC: 1879-D

IMPROVING HEAT TREATMENT OF MAGNETICALLY SOFT ALLOYS IN A VACUUM

Following is a translation of an article by N. I. Lapkin from the Russian-language book Primeneniye vakuuma v metallurgii (Application of Vacuum in Metallurgy), a Symposium, Publishing House of the Academy of Sciences of the USSR, Moscow, 1963, pages 237-248.

Among magnetically soft alloys are included alloys of iron with silicon (electrotechnical steels), aluminum, nickel, cobalt, molybdenum and other alloying elements.

The metallurgical industry is manufacturing more than 50 brands of transformer steels or electrotechnical steels (including hot-rolled, slightly and highly grain-oriented steel), and also almost 20 brands of iron-nickel, iron-nickel-molybdenum, and iron-cobalt magnetically soft alloys in the form of sheets and tape having thicknesses from 3.0 to 0.010 mm and widths from 10 to 1,000 mm.

According to their magnetic properties magnetically soft alloys are arbitrarily divided into 5 groups: 1 -- with elevated magnetic permeability and highest factor of saturation induction (45N, 50N); 2 -- with rectangular hysteresis loop, having crystallographic or magnetic texture (50NP, 47NMP, 65NP, 34NKMP, E330A); 3 -- with elevated magnetic permeability and high electrical resistance (37NS, 42NS, 50NKhS); 4 -- with high and highest magnetic permeability in weak fields (78N, 80NKhS, 79NM, 79NMA, 74NMD, 76NKhD, 80NKh); 5 -- with highest magnetic saturation and increased permeability in regions of high inductions (35KKh, 50KF).

Chemical compositions, heat-treatment conditions and magnetic properties of the main brands of magnetically soft alloys are presented in tables 1 and 2.

Today's industry, especially its latest branches -- radio-electronics, aircraft instrument-making, automation, telemechanics -- impose upon the quality of magnetically soft alloys ever higher requirements.

Table 1. Chemical Composition of Main Brands of Magnetically Soft Alloys

Brand of Alloy	Chemical Composition, %							
	Fe	Ni	Si	Mo	Co	Al	C	O
E220	97.60	0.10	2.0	--	--	0.15	0.040	0.030
E43A	95.40	0.05	4.50	--	--	0.010	0.015	0.020
E330A	96.95	0.01	3.0	--	--	0.010	0.005	0.010
Yu16	84.0	--	0.008	--	--	16.0	$5 \cdot 10^{-5}$	$1 \cdot 10^{-5}$
50N*	49.0							
65NP	34.0	65.0	0.3	Mn 0.5	--	--	0.020	0.005
80NKbS	16.0	80.0	1.5	0.5	Cr 1.5	--	0.020	0.005
79NMA*	15.0							

* On nickel basis.

Table 2. Magnetic Properties of Magnetically Soft Alloys After Annealing Under Vacuum

Brand of Alloy	Temperature, °C	Conditions of Heat Treatment			
		Vacuum, mm mercury column	Duration, hours	Speed of Cooling, °C/hr	
				1300-600°	600-300°
E220	900	30	16	200	5-10
E43A	1,100	30	20	200	5-10
E330A	1,150	30	24	200	5-10
E370	1,160	30	12	100	30
Yu-16	1,050	--	4	100	Hardening in oil
50N	1,100	10^{-4}	3-4	50-100	Air
65NP	1,100	10^{-4}	3-4	50-100	In magnetic field
80NKbS	1,100	10^{-4}	3-4	50-100	Air
79NMA	1,300	10^{-4}	3-4	50-100	Air

<u>Chemical Composition, %</u>				<u>Method Smelting</u>
<u>N</u>	$\frac{\text{cm}^2}{100 \text{ g}}$	<u>S</u>	<u>P</u>	
0.005	5.0	0.030	0.040	Open-hearth furnace
0.010	2.0	0.005	0.010	Arc furnace with vacuuming in ladle
0.005	1.5	0.003	0.005	
$3 \cdot 10^{-4}$	--	0.002	0.001	Vacuum induction furnace
				Arc vacuum furnace
0.001	5.0	0.020	0.020	Open induction furnace
0.001	5.0	0.020	0.020	Same
				Arc vacuum furnace

<u>Minimum Thickness of Tape, mm</u>	<u>V_r, kilo-gauss</u>	<u>H_c, oersted</u>	<u>Magnetic Properties</u>			
			<u>μ_0, Gauss-oersted</u>	<u>μ_{max}, Gauss-oersted</u>	<u>ρ, $\frac{\text{ohm-mm}^2}{\text{m}}$</u>	<u>d, $\frac{\text{g}}{\text{cm}^3}$</u>
0.50	23.0	0.50	500	$5 \cdot 10^3$	0.50	7.70
0.10	22.0	0.30	800	$12 \cdot 10^3$	0.60	7.55
0.35	22.5	0.20	1,200	$15 \cdot 10^3$	0.45	7.65
0.05	22.5	0.10	1,500	$20 \cdot 10^3$	0.55	7.65
0.10	9.5	0.05	4,000	$80 \cdot 10^3$	1.50	6.50
0.05	15.0	0.05	5,000	$100 \cdot 10^3$	0.45	8.25
0.10		0.05			0.45	8.20
0.05	7.5	0.01	$20 \cdot 10^3$	$300 \cdot 10^3$	0.60	8.20
0.05	7.5	0.008	$50 \cdot 10^3$	$500 \cdot 10^3$		8.20

Along with a high level of magnetic properties, magnetically soft alloys must be distinguished by homogeneity and stability, i.e., they must preserve high magnetic properties under change of the external medium -- temperature (from -60° to $+400^{\circ}$), pressure (from 760 to 10^{-6} mm mercury column), mechanical load (impact, shaking, tightening of packages), radioactive irradiations.

As experience shows, satisfying the high requirements of today's industry upon the quality of magnetically soft alloys is possible only on the condition that one uses the most highly perfected methods of melting, cold rolling and especially heat treatment, which is the final technological operation.

The technology of vacuum annealing of electrical steels, briefly presented in the literature [1-3], is still insufficiently studied and requires radical improvement. Still less studied are the physical bases of heat treatment of iron-nickel and iron-cobalt magnetically soft alloys [4-5]. But there is enough available experience to indicate ways of improving heat treatment of magnetically soft alloys: 1) improvement of construction of vacuum electric furnaces and installations; 2) increase of temperature of annealing; 3) creation of the deepest possible vacuum; 4) use of gas absorbers (getter); 5) creation of conditions for adjustment of speed of cooling upon annealing in deep vacuum; 6) annealing in vacuum with cooling in a magnetic field.

Improvement of Construction of Vacuum Furnaces and Installations

Inertial vacuum furnaces. The highest brands of electrotechnical steels at metallurgical factories are subjected to a long annealing at $1,100-1,150^{\circ}$ (Table 2) in cupola electric furnaces of type UKR-03, ensuring low vacuum (30-50 mm mercury column) and having an inleakage up to 600 mm mercury column per hour (1, a). The advantages of these furnaces, first designed by Engineer N. V. Zhukov at the Verkh-Isetsk metallurgical factory, are simplicity of construction and reliability in exploitation. The furnaces can work under the severest conditions with absence of thorough care.

After the Verkh-Isetsk metallurgical factory, cupola vacuum furnaces, prepared by the industrial enterprise "Ukrpromielektropech," were set up at all factories preparing electrotechnical steel. The technical characteristics of vacuum furnaces for annealing magnetically soft alloys are set forth in Table 3.

Table 3. Technical Characteristics of Certain Types of Electric Vacuum Furnaces Used for Annealing Magnetically Soft Alloys

<u>Designation of Furnace</u>	<u>Type (source)</u>	<u>Consumed Power, kvt</u>	<u>Operating Voltage</u>	<u>Operating Temperature, °C</u>
Cupola	UKR-03B	310	380	1,180
Muffle inertial	--	12	10	1,250
Retort	--	20	12	1,100
Muffle non-inertial	MPV-2M	40	10	1,600
Pit non-inertial	TsEP-301	75	15	1,300
Non-inertial with cylindrical screens	[8]	--	--	1,200
Non-inertial with turning flat screens	[9]	200	--	1,180

To increase magnetic properties of electrical steels it is necessary to ensure in cupola furnaces a vacuum not over 0.005 mm mercury column at an operating temperature of 1,250-1,300° and duration of the whole cycle of annealing of 120-140 hours. For this purpose it is necessary to create a vacuum in the actual muffle (Fig. 1, b), which is technically complicated to carry out. At a temperature above 1,000-1,100°

<u>Maximum Vacuum, mm mercury column</u>	<u>Quantity of Screens</u>	<u>Dimensions of Working Space, mm</u>	<u>Year of Manufacture</u>	<u>Producing Factory (firm name)</u>
50	--	4000x1500x1300	1955	"Ukrprom-elektro-pech"
10 ⁻³	--	500x200x150	1946	VIZ, "Amaryllis" plant and others
10 ⁻³	--	∅200, H=400	1945	TsNIICHM
10 ⁻⁵	5	250x80x130	1957	"Platin-opribor" plant
10 ⁻⁵	7	∅250, H=572	1958	"Tsentropromelektropech"
10 ⁻³	--	1220x1220x3660	1956	Westinghouse Electric Corp., Medville, Pennsylvania, USA
10 ⁻³	--	2400x1525x915	1956	North American Aviation, Inc., Los Angeles, California, USA

under deep vacuum a muffle of heat-resistant steel is deformed and rapidly collapses.

It is most expedient to make the cupola electric furnaces, shown in Fig. 1, c. In these furnaces an initial vacuum is created under the cupola, and in the muffle a deep vacuum. In this way the muffle oxidizes less and is not deformed during long heating in the high temperature zone.

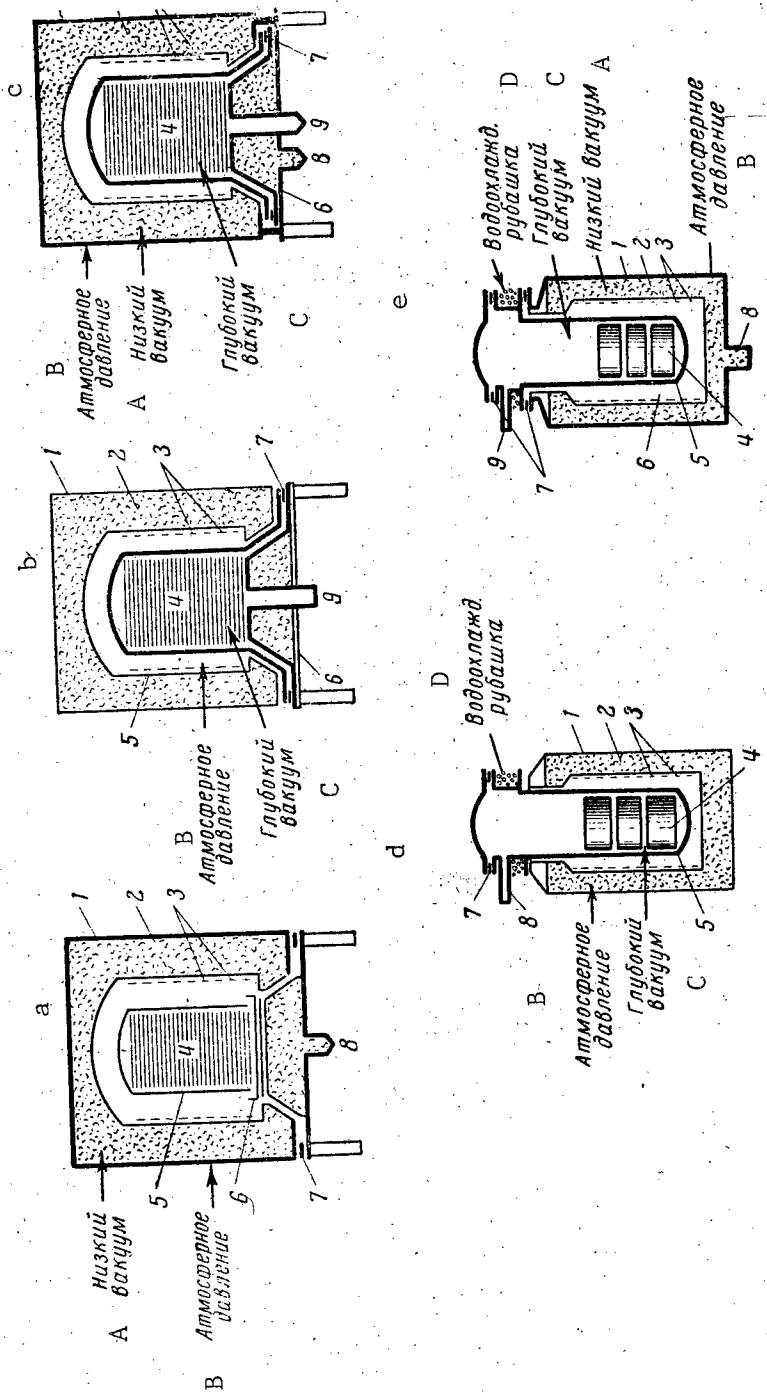

Fig. 1. Diagram of modern inertial vacuum furnaces (a, b, c, -- cupola; d, e -- pit): 1 -- housing; 2 -- fireproof lining; 3 -- heaters; 4 -- pile (charge); 5 -- muffle (of retort); 6 -- tray; 7 -- vacuum packings; 8 -- branch pipe to pump vacuum; 9 -- connection to deep vacuum pumps; A) low vacuum; B) atmospheric pressure; C) deep vacuum; D) water-cooling sleeve.

Cupola vacuum furnaces for annealing of electrical steels in piles have capacities of 10-20 t. For annealing of small piles, rolls, or stampings, weighing up to 500 kg, it is more expedient to use pit deep-vacuum furnaces with electric heating, a diagram of which is presented in Fig. 1, d, e.

Improvement of designs of housing, muffle and vacuum drive of existing cupola vacuum furnaces for annealing of electrotechnical steels will make it possible to use, instead of low-vacuum water-ring pumps (types RMK-3--RMK-4), valve-oil pumps (type VN-6) in combination with boosters (BN-3, BN-1,500 and others) and steam oil-pumps (N-8T) and deep-vacuum traps. Instead of heaters of alloy OKh25Yu5, cupola vacuum furnaces, intended for annealing of the highest brands of electrotechnical steels, will have to be equipped with more heat-resistant molybdenum heaters.

Non-inertial deep-vacuum furnaces. In late years (1955-1960), for heat treatment of stampings and ready-made magnetic circuits of electrotechnical steels and especially iron-nickel, iron-nickel-molybdenum, and iron-cobalt magnetically soft alloys, but also for annealing of articles of titanium, wide use has been made of non-inertial electric furnaces, in which fire-proof lining is replaced by metallic screens of iron-nickel alloys, stainless steel or molybdenum [6-9]. For heaters for non-inertial deep-vacuum furnaces molybdenum is used. The operating temperature of stoves can attain 1,400-1,600° at a vacuum of 10^{-5} mm mercury column.

Technical characteristics and schematic organization of the main types of non-inertial deep-vacuum furnaces made in the USSR and the United States are presented in Table 3 and in Fig. 2-3 [7-8].

Non-inertial vacuum furnaces of native manufacture of type TsEP-301 and MPV-2M are reliable in use and are distinguished by comparatively small dimensions of working space. The furnace TsEP-301 is of pit type, with motionless cylindrical screens, power 50-75 kilowatts. The furnace is serviced by three vacuum pumps (plunger VN-1, booster BN-3 and steam oil-pump N-5) and ensures in heated state a vacuum of $5 \cdot 10^{-5}$ mm mercury column. Feed of furnace is from transformer OSU-80. Temperature is regulated with accuracy of plus or minus 10° via an autotransformer AOMK-100 (0.5), a potentiometer MPShchPr-54 with a millivoltmeter and a platinum-platinorodium thermocouple.

Distinctive peculiarities of non-inertial vacuum furnaces made in the United States, are large dimensions of

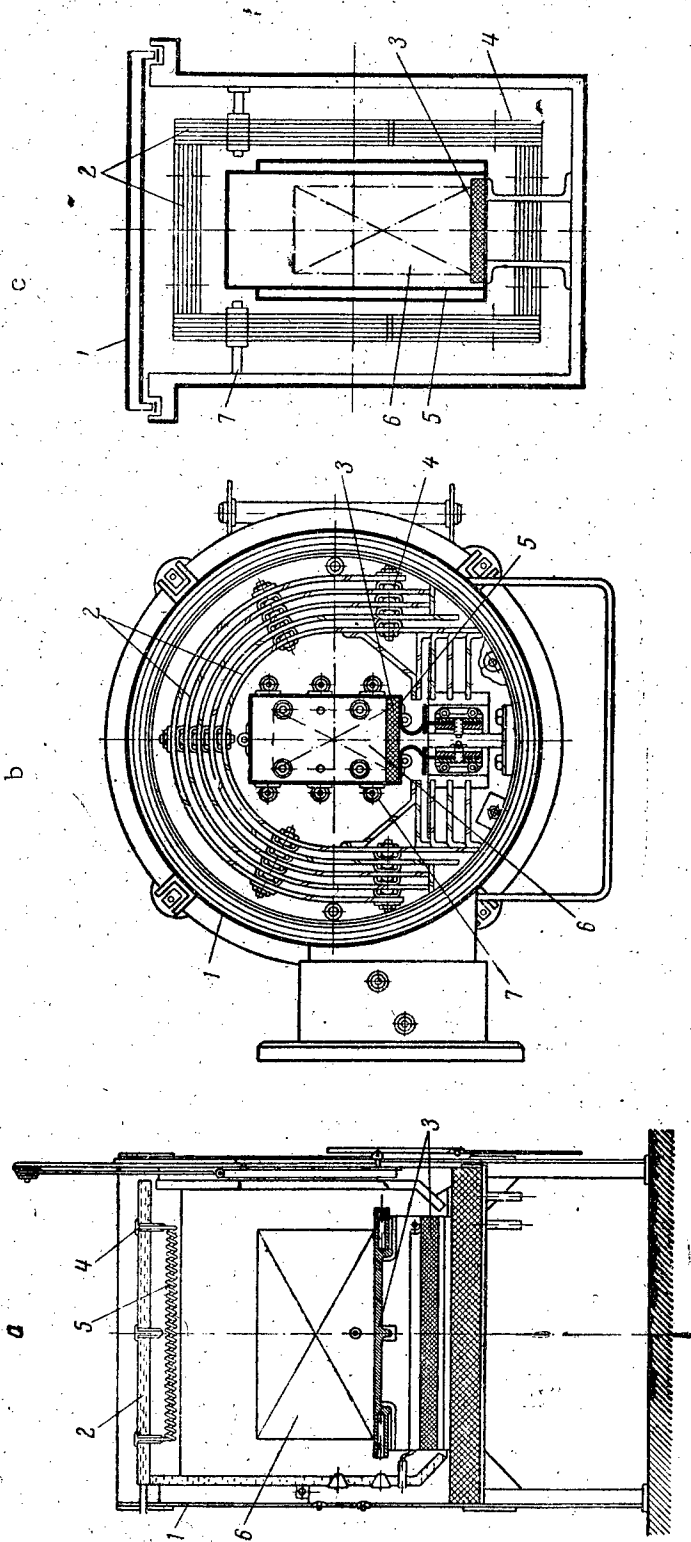

Fig. 2. Non-inertial deep-vacuum furnaces made in the USSR (a -- furnace of M. A. Kuzmin, LPI; b -- furnace of type MPV-2M, "Platinopribor" plant; c -- furnace of type TsEP-301, "Elektrojech" trust): 1 -- water-cooled housing; 2 -- screens; 3 -- bottom slab (alundum, quartz); 4 -- ceramic insulators; 5 -- electric heaters; 6 -- charge; 7 -- frame for suspension of heaters.

to vacuum pumps

к вакуумнасосу

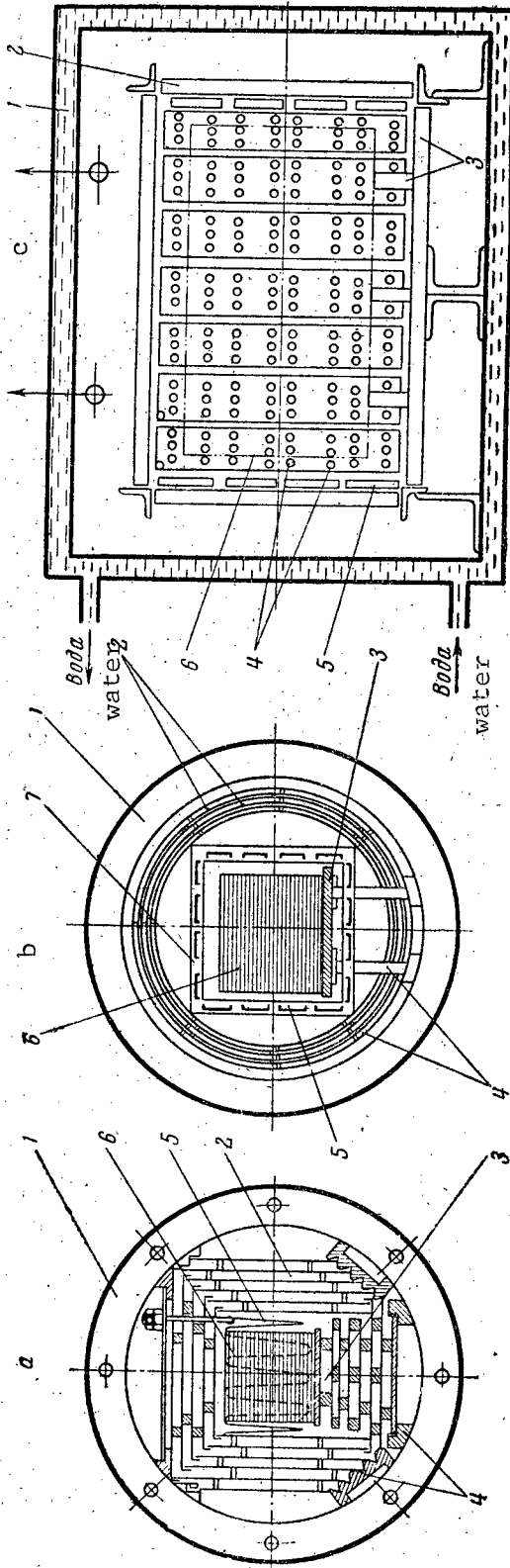

Fig. 3. Non-inertial deep-vacuum furnaces made in the United States [8, 9] (designations same as in Fig. 2): a -- with motionless flat screens; b -- with cylindrical screens; c -- with turning flat screens.

working space (length up to 6,000 mm), large consumed power (200 kilowatt), arrangement of screens on turning panels (Fig. 3, b) with forced cooling of annealed articles by neutral gases. In stove with turning flat panels, the screens together with the spiral heaters are fastened on seven panels independent one from another, which can without disturbance of vacuum be turned 180° , thereby significantly accelerating the process of cooling annealed articles. Charging the furnace is carried out with the help of a ground-type loading machine through an unscrewing end door. Articles are placed on 27 graphite (or alundum) supports of cylindrical form, fixed in three rows on the bottom of the furnace. The furnace is fully automated and is intended for annealing and brazing articles of titanium weighing up to 50 t under vacuum less than 10^{-2} mm mercury column at $1,180^\circ$ with long duration [9].

Multizone semicontinuous deep-vacuum furnaces. The electric vacuum furnace of semicontinuous action [8] has three zones: I -- degassing, II -- heating, and III -- cooling. In each zone a vacuum is created from three independent vacuum systems. The deepest vacuum is created in the zone of heating, the initial vacuum in the zone of degassing and cooling. The article to be annealed is periodically moved from one zone into another, without disturbance of vacuum. In each of the zones there are created necessary conditions for carrying out the proper technological operations; removal of occluded gases and vapors from the surfaces of articles, heating of metal, and accelerated cooling.

Three-zonal semicontinuous deep-vacuum furnaces are used in the United States for heat treatment of components made of heat-resisting alloys. Such a furnace can be used with success for low-temperature annealing of dynamo and transformer steels in place of the tunnel furnaces now used, which work on liquid fuel without protective devices.

Multizone vacuum furnaces of continuous action can be made, when necessary, on the principle of non-inertial vacuum furnaces, with turning flat screens and electric heaters.

Increase of Magnetic Properties of Electrotechnical Steels Upon Annealing Under Deep Vacuum

Increase of temperature of annealing to $1,250-1,300^\circ$ and lowering of pressure in furnace to $10^{-3} - 10^{-4}$ mm mercury column ensure removal from sheet transformer steel of gases (H_2 , CO , CO_2 , CH_4), and also of the more stable chemical compounds (nitrides, sulfides). In the process there are removed internal stresses and distortions of the crystalline network.

High-temperature annealing makes it possible to increase magnetic permeability and induction in weak and average fields in steel containing 3.0-4.0 o/o Si by 2-3 times, but also significantly to lower loss on hysteresis and coercive force $\sqrt{10-11}$ %. But even in workshop conditions, upon annealing in a retort, when the temperature of annealing does not exceed 1,100-1,150°, it is possible, upon increase of vacuum from 50 to 0.1 mm mercury column, to increase magnetic induction and to lower specific losses of hot-rolled transformer steels by 20-30 o/o, something which is of great practical significance (Fig. 4).

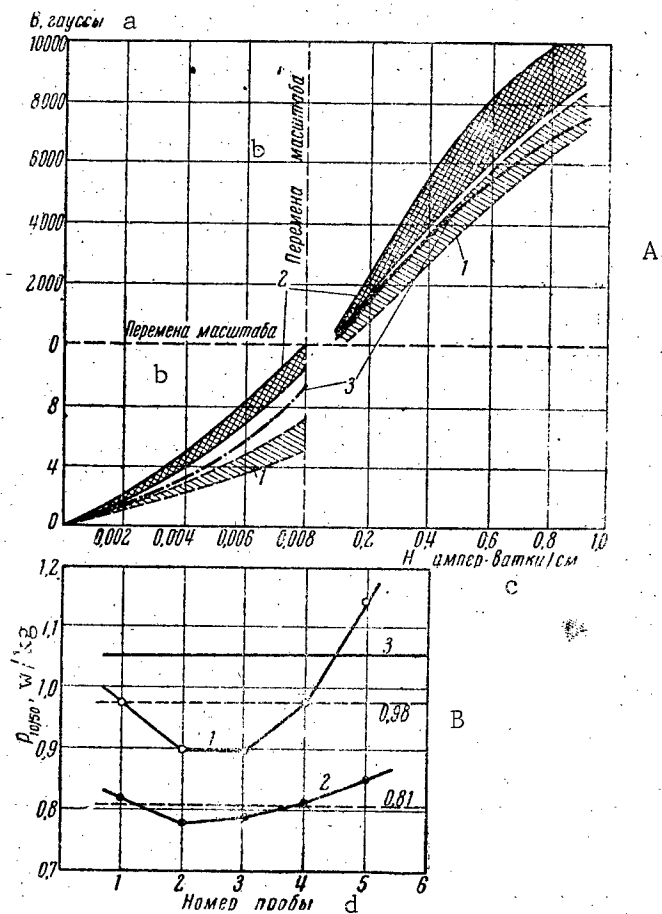

Fig. 4. Influence of depth of vacuum on magnetic induction (A) and specific losses (B) of transformer steels; 1 -- annealing in cupola furnace UKP-03B, vacuum 50 mm mercury column; 2 -- annealing in retort, vacuum 0.1 mm mercury column; 3 -- requirement of All-Union Government Standard 802-58 (brands E46 and E43). a) B , Gauss; b) change of scale; c) H ampere-vatki/cm; d) number of test.

As is known, all brands of hot-rolled and little-textured dynamo steels and medium-alloyed transformer steels are subjected to a final low-temperature (800-850°) annealing in tunnel or cupola furnaces. As can be seen from Table 4, low-temperature annealing under deep vacuum (in a retort) affords the possibility of lowering specific losses of hot-rolled transformer steels by 5-10 o/o. Besides, the more contaminated the steel is by harmful impurities and gases, the greater the effect of low-temperature annealing under vacuum. Thus, specific losses of transformer steels, melted in open-hearth furnaces, can (thanks to such annealing) be lowered to the level of specific losses of electric steel.

The experiments carried out allow one to recommend use of low-temperature cupola deep-vacuum furnaces in place of tunnel ones for heat treatment of all brands of hot-rolled dynamo and transformer steels with content of 1.2 and 3 o/o Si.

The opinion of certain production workers to the effect that deeper vacuum does not have vital significance for so-called ordinary brands of electrotechnical steels (E12, E22, E31, E41), is refuted by the experiments.

Table 4. Magnetic Properties of Hot-Rolled Transformer Steels of 0.35-mm Thickness After Low-Temperature Annealing in Cupola Furnace (vacuum 50 mm mercury column) and a Retort (vacuum 0.5 mm mercury column)

Number of Anneal	Furnace			Retort		
	R10/50, w/kg	R15/50, w/kg	V25, Gauss	R10/50, w/kg	R15/50, w/kg	V25, Gauss
Open-hearth steel						
1	1.32	3.03	14890	1.12	2.66	14500
2	1.33	2.89	14900	1.25	2.82	14800
3	1.34	3.14	14800	1.30	2.99	14900
Average	1.33	3.02	14800	1.22	2.82	14700
Electric steel						
1	1.18	2.67	14400	1.14	2.55	14500
2	1.21	3.18	14500	1.13	2.69	14700
3	1.27	2.96	14700	1.19	2.77	14900
Average	1.22	2.93	14500	1.15	2.67	14700

Heat Treatment of Iron-Nickel Alloys

Although iron-nickel alloys, like iron-silicon ones, represent single-phase solidified solutions and fall into a single class of magnetically soft alloys, their heat treatment has vital peculiarities, which it is necessary to take into account.

As can be seen from Fig. 5, maximum magnetic properties of the iron-nickel alloys 50N and 79NM, even in case of annealing under a vacuum of 10^{-4} mm mercury column (in non-inertial deep vacuum furnaces), can be secured only under an optimum temperature of annealing. For alloy 50N, melted in an arc vacuum furnace and having a minimum content of harmful impurities, the best magnetic properties were secured at an annealing temperature of $1,200-1,250^{\circ}$ (Fig. 5, a). In alloy 79NM, alloyed with molybdenum and re-melted in an arc vacuum furnace, it turned out to be possible to secure high magnetic properties at an annealing temperature of $1,100-1,150^{\circ}$, while alloys of the same composition, melted in an open induction furnace, ensure high magnetic properties only at an annealing temperature of not less than $1,300^{\circ}$ (Fig. 5, b). As to how great an influence is exerted upon the grain size (and consequently also on the final magnetic properties) of iron-nickel alloys by the magnitude of deformation on first ($R_1 = 25, 50$ and 75 o/o) and on second ($R_2 = 5, 15, 25, 45, 65, 75, 85$ and 95 o/o) cold rolling, it is possible to judge on the basis of the experimental data set forth in Fig. 5, b.

Thus in order to obtain high magnetic properties for iron-nickel alloys, mere increase of annealing temperature and deep vacuum are insufficient. These alloys are decidedly sensitive to deformation, conditions of cooling, and temperature and medium of final annealing.

It is known that magnetically soft alloys with rectangular hysteresis loop can be secured either by means of very high squeezing pressure during final cold rolling (alloy 50NP), or by cooling in a magnetic field at a temperature somewhat higher than the Curie point (alloy 65NP).

It has been observed that for an increase of maximum magnetic permeability of iron-nickel alloys delayed cooling is required, but for an increase of initial magnetic permeability accelerated cooling is required.

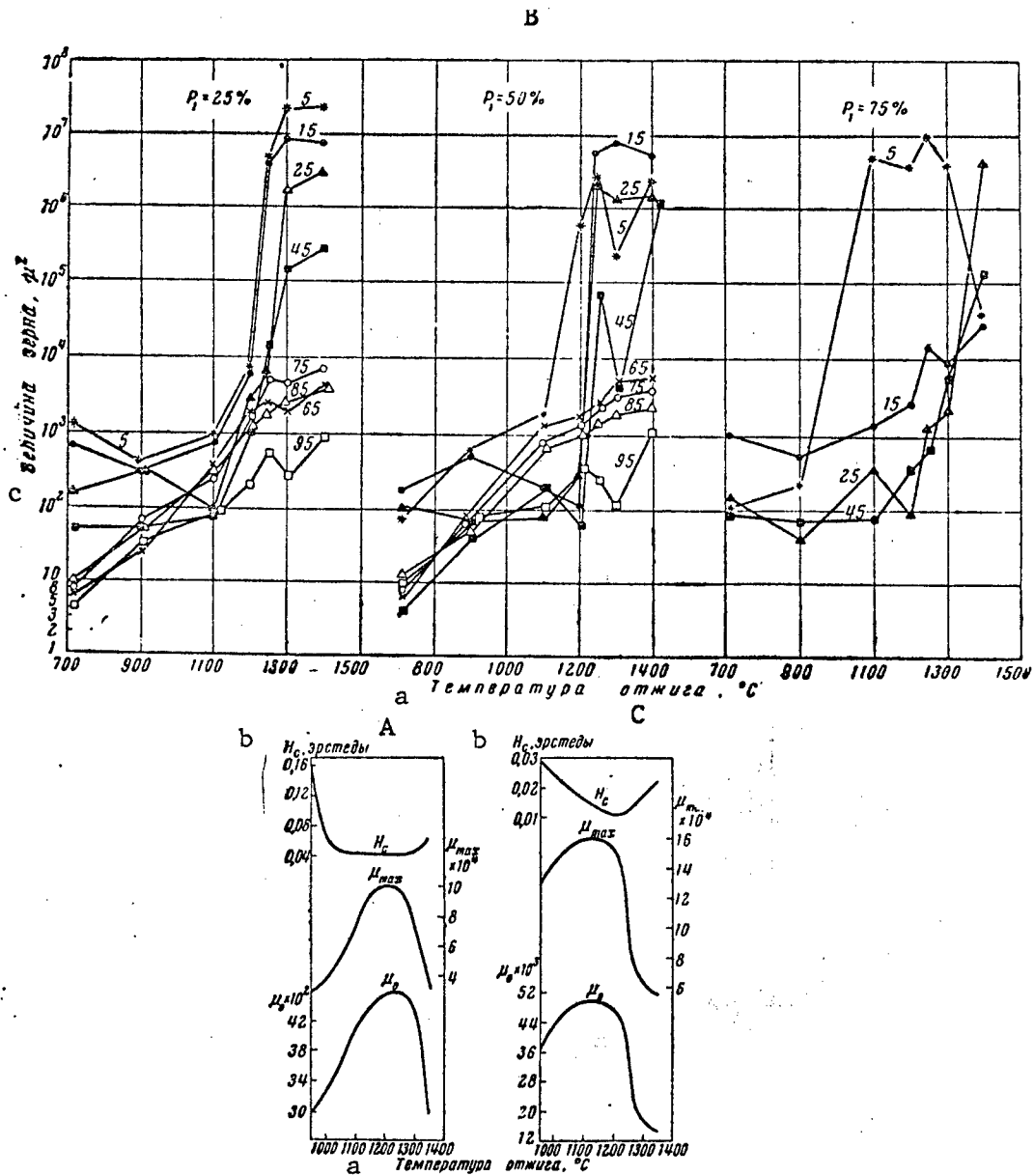

Fig. 5. Influence of temperature of deep-vacuum annealing on magnetic properties and grain size of iron-nickel alloys of brands 50N (A, B) and 79NM (C). Annealing in furnace MPV-2M, vacuum 10^{-4} mm mercury column. a) Temperature of annealing; b) oersteds; c) grain size.

Literature

1. N. I. Lapkin, S. L. Lifshitsyn, Reports at a theoretical oral discussion on magnetically soft materials, 18-21 March 1958, Vol 1, pages 113-123, Central Scientific Research Institute of Ferrous Metallurgy, Moscow.
2. N. F. Dubrov, Bulletin of Central Scientific Research Institute of Ferrous Metallurgy, 1958, No 9 (341), 29-33; Industrial-economic Bulletin of the Sverdlovsk National Economy Council, 1958, No 4, 8-11; "Steel," 1958, No 3, 246-48.
3. S. L. Lifshitsyn, In. T. Tilk, A. G. Toropov, Production of electrical sheet steel, Symposium of articles, Metallurgizdat, 1959, pages 89-94.
4. N. I. Lapkin, V. S. Meskin, Publishing House of the Academy of Sciences of the USSR, physics series, 1959, 23, No 3, 280-84.
5. N. I. Lapkin, Production Problems in the Use of Electrotechnical Steels, Symposium of articles, Sverdlovsk National Economy Council, 1960.
6. M. A. Kuzmin, Non-inertial furnaces, Mashgiz, 1950.
7. Vacuum metallurgy, Translated from English under editorship of A. M. Samarik, Foreign Literature Press, 1960, page 157.
8. R. P. Giler, Industrial heating, 1956, No 10, 2038-2050.
9. P. Fair, Industrial heating, 1957, No 10, 1981-1986.
10. V. S. Meskin, N. I. Lapkin, The Physics of Metals and Metallography, 1955, Vol I, first edition.
11. N. I. Lapkin, G. A. Zykov, Bulletin of Scientific and Technical Information of the Ural Scientific Research Institute for Ferrous Metallurgy, 1958, No 4, 45-52.
12. Precision Alloys, Studies of the Central Scientific Research Institute of Ferrous Metallurgy, issue 23, Metallurgizdat, 1960.

5463
CSC: 1879-D

- END -