

AD _____

Award Number: DAMD17-99-1-9336

TITLE: Oxidases as Breast Cancer Oncogens

PRINCIPAL INVESTIGATOR: Anjana Yeldandi, M.D.

CONTRACTING ORGANIZATION: Northwestern University Medical School
Evanston, Illinois 60208-1110

REPORT DATE: June 2001

TYPE OF REPORT: Annual

PREPARED FOR: U.S. Army Medical Research and Materiel Command
Fort Detrick, Maryland 21702-5012

DISTRIBUTION STATEMENT: Approved for Public Release;
Distribution Unlimited

The views, opinions and/or findings contained in this report are those of the author(s) and should not be construed as an official Department of the Army position, policy or decision unless so designated by other documentation

20011127 053

REPORT DOCUMENTATION PAGE

Form Approved
OMB No. 074-0188

Public reporting burden for this collection of information is estimated to average 1 hour per response, including the time for reviewing instructions, searching existing data sources, gathering and maintaining the data needed, and completing and reviewing this collection of information. Send comments regarding this burden estimate or any other aspect of this collection of information, including suggestions for reducing this burden to Washington Headquarters Services, Directorate for Information Operations and Reports, 1215 Jefferson Davis Highway, Suite 1204, Arlington, VA 22202-4302, and to the Office of Management and Budget, Paperwork Reduction Project (0704-0188), Washington, DC 20503

1. Agency Use Only (Leave blank)	2. Report Date June 2001	3. Report Type and Period Covered (i.e., annual 1 Jun 00 - 31 May 01) Annual (1 Jun 2000 - 31 May 2001)
---	------------------------------------	---

4. Title and Subtitle Oxidases as Breast Cancer Oncogens	5. Award Number DAMD17-99-1-9336
--	--

6. Author(s) Anjana Yeldandi, M.D.	
--	--

7. Performing Organization Name Northwestern University Medical School Evanston, Illinois 60208-1110 E-Mail: a-yeldandi@northwestern.edu	8. Performing Organization Report Number (Leave Blank)
---	---

9. Sponsoring/Monitoring Agency Name and Address U.S. Army Medical Research and Materiel Command Fort Detrick, Maryland 21702-5012	10. Sponsoring/Monitoring Agency Report Number (Leave Blank)
---	---

11. Supplementary Notes (i.e., report contains color photos, report contains appendix in non-print form, etc.)

12a. Distribution/Availability Statement (check one) Approved for public release; distribution unlimited	12b. Distribution Code
--	-------------------------------

13. Abstract (Maximum 200 Words) (abstract should contain no proprietary or confidential information)

This proposal examines the novel concept that H₂O₂ generating oxidase-mediated reactive oxygen species in breast epithelium contribute to the development of breast cancer. Constructs to express xanthineoxidase under the direction of mouse mammary tumor virus (MMTV) promoter were generated. Transfections performed to generate cell lines stable expressing the enzyme were unsuccessful hence urate oxidase was used as an alternative. The choice for urate oxidase is based on the fact that we have used this enzyme in previous studies and showed that cells expressing this enzyme reveal the characteristic crystals of this enzyme in peroxisomes. Transgenic mice expressing UOX under the transcriptional control of MMTV promoter were generated. We have injected the construct in fertilized ova and identified five founder mice initially which failed to transmit the transgene. Additional microinjections generated 9 founders. Five of these were found to express the transgene. Southern, Northern and Western analyses showed the presence of the transgene in the mammary, and testicular tissues. We will now initiate studies to examine the role of reactive oxygen species in causing cell death, cell proliferation and neoplastic transformation.

14. Subject Terms (keywords previously assigned to proposal abstract or terms which apply to this award)	15. Number of Pages 15
	16. Price Code

17. Security Classification of Report Unclassified	18. Security Classification of this Page Unclassified	19. Security Classification of Abstract Unclassified	20. Limitation of Abstract Unlimited
--	---	--	--

Table of Contents

Cover	1
SF 298	2
Foreword	3
Table of Contents	4
Introduction	5
Body	6
Key Research Accomplishments	12
Reportable Outcomes	13
Conclusions	14
References	15
Appendices...	

INTRODUCTION

Carcinoma of the breast is overwhelmingly a disease of females. In the United States, the age-standardized incidence of breast cancer has doubled during the past four decades. The established risk factors are both non-hormone mediated and hormone-mediated. Oxygen free radicals are a well-established risk factor for cancer and aging. Evidence for the role of free radical-induced DNA damage in aging, and cancer comes from the correlations between high consumption of fruit and vegetables, or of specific dietary antioxidants and a relatively low incidence of several types of cancers. Recent literature suggests a role for free radical induced injury in the development of breast cancer. The idea of free radical induced injury having a role in breast cancer development is intriguing since it opens up the possibility of antioxidants being able to prevent its development.

Our idea or hypothesis is that the increased incidence of breast cancer in the United States is due to increased generation of reactive oxygen species (ROS) in the breast epithelium during the reproductive period and antioxidant activity will be beneficial in preventing breast cancer. Accordingly, our idea is based on the notion that xanthine oxidase (XOX), which is present in milk for possible antimicrobial activity, to keep the milk sterile, plays havoc with the breast epithelium of women at risk. We will test the idea that XOX or a different hydrogen peroxide-generating oxidase such as urate oxidase (UOX) over-expression in breast epithelium leads to neoplastic transformation using *in vitro* and *in vivo* transgenic approaches. For this purpose stably transfected mammary epithelial cells will be generated and exposed to xanthine for XOX or uric acid for UOX cells to produce H₂O₂/ ROS and transformation potential will be assessed. Likewise, we will generate transgenic mice over-expressing UOX under the control of mouse mammary tumor virus (MMTV) promoter. We have considerable past experience *in vitro* transformation work using peroxisomal fatty acyl-CoA oxidase and peroxisomal urate oxidase in African green monkey kidney cells and we also have the expertise in our laboratories to generate transgenic mice [1, 2]. .

Body

We are testing the idea that XOX or UOX overexpression in breast epithelium leads to neoplastic transformation using *in vitro* and *in vivo* transgenic approaches. Our proposal will test the idea that XOX mediated generation of ROS in breast epithelium contributes to the development of breast cancer and that XOX levels are hormonally regulated, with highest enzymatic activity in breast epithelium during the reproductive phase of female biology. The hypothesis that breast cancer is due to ROS generated by XOX, or other H₂O₂-generating oxidases such as UOX, will be tested using molecular genetic approaches. The specific aims of the proposed study will address the fundamental issues related to our idea/hypothesis regarding the role of ROS in breast cancer pathogenesis.

Specific Aim : Generate transgenic mouse lineages that overexpress urate oxidase under the control of MMTV-LTR promoter and utilize this *in vivo* model to explore the role of urate oxidase-generated ROS in the development of breast cancer. The goal here is to develop transgenic mouse models to study the role of ROS in breast carcinogenesis.

Construction of Urate oxidase (UOX) expression plasmid under the control of MMTV promoter:

Rat UOX cDNA, previously cloned in our laboratory was used as template to PCR amplify the coding region and cloned into MMTV promoter plasmid at the EcoR I sites of exon 3 region as shown in the Fig. 1. The plasmid contains exon 2 and exon 3 of rabbit beta globin genomic DNA, under the control of MMTV promoter. The plasmid was sequenced and verified for mutational errors and the entire cassette consisting of MMTV promoter, Exon 2 and Exon 3 of rabbit beta globin, rUOX along with Poly A tail was released with double digestion of Hind III and XhoI restriction enzymes. This cassette was used for the generation of chimera mice.

Generation and Characterization of transgenic mice expressing urate oxidase:

We have successfully microinjected the cassette containing MMTV-rUOX into the fertilized ova and generated transgenic mice by implanting these ova in pseudo-pregnant mice. Analyses of 2-week old mouse-tail DNA was performed by Southern blotting and by polymerase chain reaction of partial cDNA of 300 bps. We have previously reported the identification of 5 founders (3 males and 2 females), but these mice were found to be either unproductive or failed to transmit the rUOX transgene to their siblings (Fig. 2). Further injection of ova to generate more founders were taken up and subsequent analyses of the pups generated showed 9 more pups carrying the transgene (Fig 3). These founders (males designated as □ and females designated as O) were bred with wild type male or female mice .

Transgenic analyses of the offspring were carried out by tail genomic DNA analyses which was digested with EcoRI restriction enzyme and Southern blot analyses (Tail genomic DNA was isolated and after restriction digestion was blotted onto a nylon membrane and probed with linearized and labeled UOX cDNA probe). Out of the 9 founders, two founders were found to be non-reproductive (Nos. 189 and 197, designated with X) and also 2 founders did not transmit the transgene to their offspring (Nos. 189 and 201, designated with XX). 5 founders successfully transmitted the gene to their offspring (Fig. 3). These heterozygous offspring (either from the same parent/founder, or from different founders, are shown in the fig. 3) were bred to generate homozygous offspring, in order to boost transgenic expression. A representative Southern analyses is shown in Fig. 4.

Heterozygous were analyzed for UOX expression. Northern analyses showed UOX mRNA expression in testis (Fig.5b) and in Breast (Fig.5d). UOX expression in liver is shown as control (Fig 5a and c). Western analyses confirmed the presence of UOX protein (Fig. 6).

Rabbit β globin genomic DNA

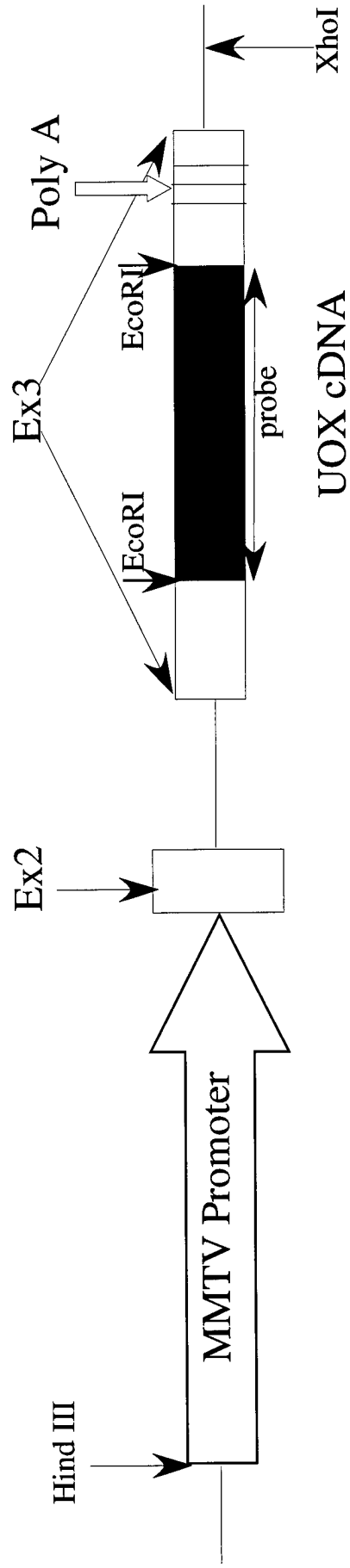
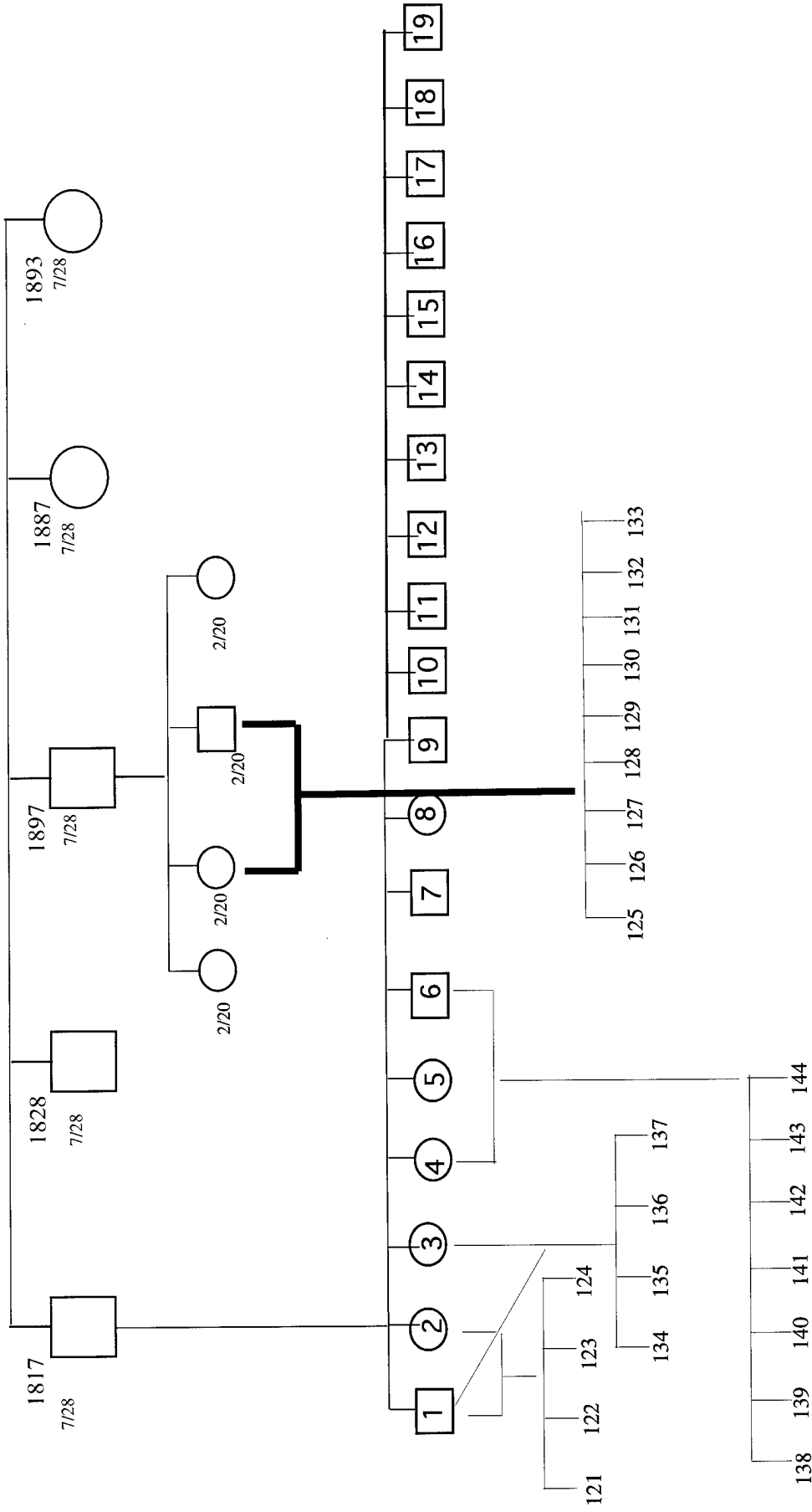

Fig.1 Transgene construct of MMTV-UOX

MMTV-UOX

Fig.2:



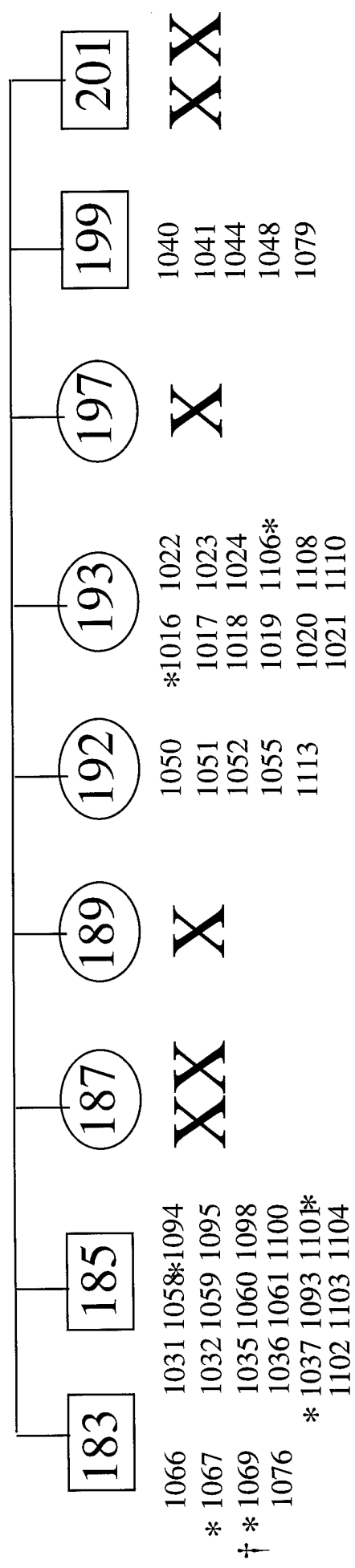
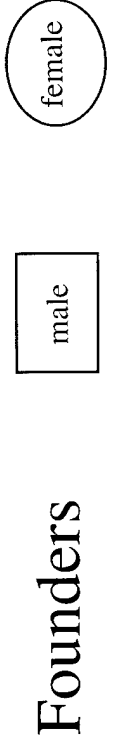

Fig. 3:

* RNA positive mice

† Protein positive mice

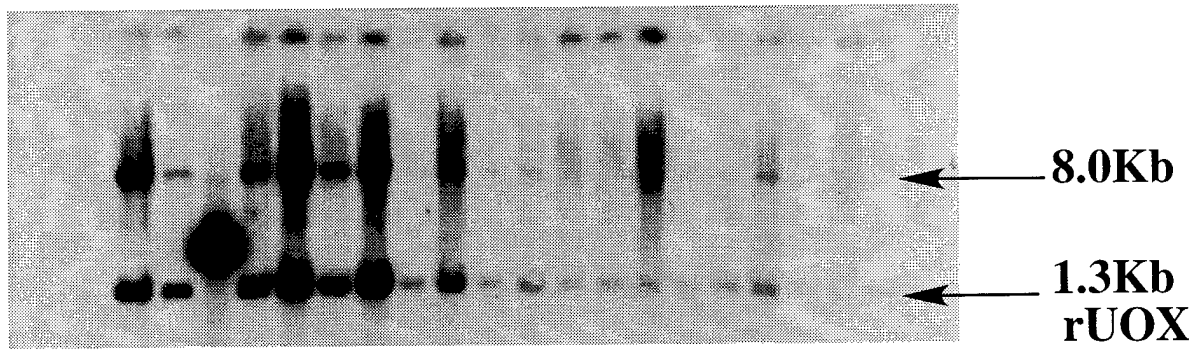

Fig. 4 : Southern Blot analysis of transgenic mice: mouse tail genomic DNA was isolated and restriction digested with EcoR I. The digested DNA was electrophoresed on 1% agarose gel and transferred to nylon membrane. The membrane after blocking was probed with labeled rUOX probe.

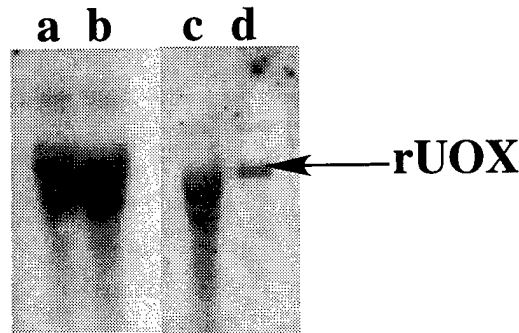

Fig. 5: Northern blot analysis: Total RNA was isolated from testis, liver and mammary tissue and electrophoresed on a 1% agarose gel. The gel was transferred to nitrocellulose membrane and probed with rUOX cDNA labelled probe and exposed to x-ray film. Liver:a &c, testis:b, mammary tissue:d.

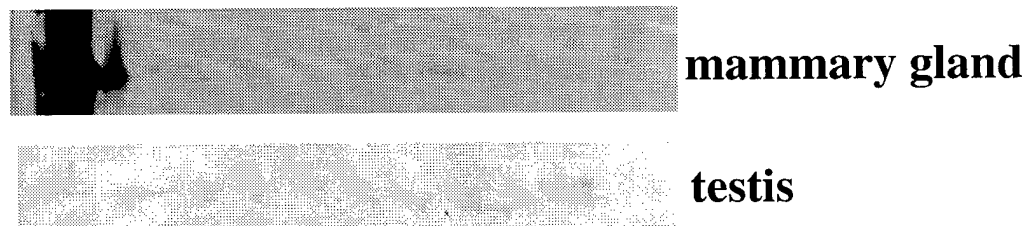

Fig.6: Western blot analysis: UOX expressing tissue of mammary and testis, were homogenized in PBS and separated on a 10% SDS-PAGE. Proteins transferred on to nitrocellulose membrane was probed with anti uox antibody and developed with NBT/BCIP reaction.

KEY RESEARCH ACCOMPLISHMENTS

- Construction of plasmids for in vitro expression
- Construction of MMTV-UOX transgene for the generation of transgenic mice
- Microinjection of transgene into fertilized ova and generation of 14 founder mice.
- Founders were bred with wildtype and germ-line transgenics were established.
- Heterozygous mice containing rUOX were identified by Southern analyses
- Southern positives were screened for RNA expression by Northern analyses
- 7 heterozygous mice from 3 founders were found to be RNA positive
- RNA positive mice were also screened for protein expression and identified by Immunoblot analyses

REPORTABLE OUTCOMES

- Review entitled “Hydrogen peroxide generation in peroxisome proliferator-induced oncogenesis” by Yeldandi, A.V., Rao, M.S., and Reddy, J.K. *Mutation Research* 448:159-177, 2000

CONCLUSIONS

We have successfully generated heterozygous mice and confirmed that they have a functional transgene (UOX), which was confirmed by Southern blot, Northern blot and Immunoblot analyses. We will initiate studies to examine the role of reactive oxygen species in cell death, cell proliferation and neo plastic transformation in mammary cells expressing urate oxidase

REFERENCES:

1. Yeldandi, A.V., M.S. Rao, and J.K.Reddy, *Hydrogen peroxide generation in peroxisomes proliferator-induced oncogenesis*. Mutat Res, (2000) 44: 159-77.
2. Yeldandi, A.V., et al., *Functional expression and peroxisomal targeting of rat urate oxidase in monkey kidney cells*. Gene Expt, (1995) 125-32.
3. Chu,R., et al., *Transformation of epithelial cells stably transfected with h2O2-generating peroxisomal urate oxidase*. Cancer Reseaqrch, (1996) 4846-52.