

AD _____

Award Number: DAMD17-97-1-7284

TITLE: The Molecular Basis of the Response to Radiation

PRINCIPAL INVESTIGATOR: Sharon E. Plon, M.D., Ph.D.

CONTRACTING ORGANIZATION: Baylor College of Medicine
Houston, Texas 77030-3498

REPORT DATE: July 2001

TYPE OF REPORT: Annual

PREPARED FOR: U.S. Army Medical Research and Materiel Command
Fort Detrick, Maryland 21702-5012

DISTRIBUTION STATEMENT: Approved for Public Release;
Distribution Unlimited

The views, opinions and/or findings contained in this report are those of the author(s) and should not be construed as an official Department of the Army position, policy or decision unless so designated by other documentation.

20011128 190

REPORT DOCUMENTATION PAGE

Form Approved
OMB No. 074-0188

Public reporting burden for this collection of information is estimated to average 1 hour per response, including the time for reviewing instructions, searching existing data sources, gathering and maintaining the data needed, and completing and reviewing this collection of information. Send comments regarding this burden estimate or any other aspect of this collection of information, including suggestions for reducing this burden to Washington Headquarters Services, Directorate for Information Operations and Reports, 1215 Jefferson Davis Highway, Suite 1204, Arlington, VA 22202-4302, and to the Office of Management and Budget, Paperwork Reduction Project (0704-0188), Washington, DC 20503

1. AGENCY USE ONLY (Leave blank)		2. REPORT DATE July 2001	3. REPORT TYPE AND DATES COVERED Annual (01 Jul 00 - 30 Jun 01)	
4. TITLE AND SUBTITLE The Molecular Basis of the Response to Radiation			5. FUNDING NUMBERS DAMD17-97-1-7284	
6. AUTHOR(S) Sharon E. Plon, M.D., Ph.D.				
7. PERFORMING ORGANIZATION NAME(S) AND ADDRESS(ES) Baylor College of Medicine Houston, Texas 77030-3498 E-Mail: splon@bcm.tmc.edu			8. PERFORMING ORGANIZATION REPORT NUMBER	
9. SPONSORING / MONITORING AGENCY NAME(S) AND ADDRESS(ES) U.S. Army Medical Research and Materiel Command Fort Detrick, Maryland 21702-5012			10. SPONSORING / MONITORING AGENCY REPORT NUMBER	
11. SUPPLEMENTARY NOTES				
12a. DISTRIBUTION / AVAILABILITY STATEMENT Approved for Public Release; Distribution Unlimited				12b. DISTRIBUTION CODE
13. ABSTRACT (Maximum 200 Words) In the second year of this three year IDEA Award we have continued to make progress towards all three Technical Objectives. The most challenging problem is the isolation of novel cDNAs encoding human homologs of yeast DNA damage response genes. Major efforts to isolate cDNAs for <i>RAD9</i> and <i>DUN1</i> during year 1 and year 2 have not been successful. In contrast, two hybrid screens have resulted in the isolation of human homologs of <i>RAD18</i> and <i>RAD21</i> . Thus, the focus over year 2 has been the characterization of the human Rad21 protein in mammalian cells. We found alterations in expression of human Rad21 mRNA and protein in human breast cancer cell lines. This has lead to development of immunohistochemistry techniques to now expand this research to human breast cancer samples. In Technical Objective 3 we did not see alteration in <i>RAD21</i> mRNA or Rad21 protein phosphorylation in human cells exposed to DNA damage. However, we found that induction of the apoptotic pathway (as opposed to DNA damage itself) induces specific cleavage of the human Rad21 cohesin protein. This cleavage product may play a role in signalling subsequent events in apoptosis or result in aneuploidy in cells that survive the apoptotic response.				
14. SUBJECT TERMS Breast Cancer			15. NUMBER OF PAGES 23	16. PRICE CODE
17. SECURITY CLASSIFICATION OF REPORT Unclassified	18. SECURITY CLASSIFICATION OF THIS PAGE Unclassified	19. SECURITY CLASSIFICATION OF ABSTRACT Unclassified	20. LIMITATION OF ABSTRACT Unlimited	

Table of Contents

Cover.....	1
SF 298.....	2
Table of Contents.....	3
Introduction.....	4
Body.....	4-8
Key Research Accomplishments.....	9
Reportable Outcomes.....	9
Conclusions.....	10
References.....	
Appendices.....	

A. Introduction

The goal of this project is to further define at a molecular level the human gene products required for the normal cell cycle response after DNA damage. The checkpoint response is a fundamental mechanism by which cells control their cell division cycle after experiencing DNA damage from radiation. This response results in an arrest in the G1, S and G2 phases of the cycle until damage is repaired. This checkpoint response is conserved among eukaryotes including the budding yeast *Saccharomyces cerevisiae*. Human cells have an additional response which results in apoptosis after DNA damage. In our application, we proposed to exploit the conservation between yeasts and humans to isolate human checkpoint genes by large scale complementation screens and homology searches isolating novel human cDNAs which can complement yeast G2 checkpoint mutant strains. Subsequent Technical Objectives were directed towards understanding the structure and expression of these genes in both normal and malignant mammary cells. The final Technical Objective was to determine the impact of exogenous expression of these genes on DNA damage responses. In this final report we detail progress during the four years of this Career Development Award towards all three objectives. This grant was co-funded with a companion IDEA Award for the PI, Dr. Sharon Plon (grant #DAMD17-98-1-8281).

B. Progress toward completing the proposed Technical Objectives.

RESULTS

Technical Objective 1 - Isolation of additional human G2 checkpoint genes.

- a. **Complementation Assay:** As previously described, this work comprised the initial years of this award. Human cDNA libraries were screened by expression in yeast *rad9*, *cdc9-8* and *mec1*, *cdc9-8* strains as described in the application. Despite extensive screening no human cDNAs which could reproducibly rescue the checkpoint defect of these strains was identified
- b. A second approach to isolating human checkpoint genes utilized homologous regions between evolutionarily distant species (*S. cerevisiae* and *S. pombe*) to develop degenerate PCR based primers. For example, a fission yeast homolog of *RAD9* named *rhp9* was published. Alignment of those sequences revealed areas of homology that may suggest conserved regions of the protein. One such area is in the carboxy terminus consistent with the known BRCT domain. During year 2 we made a major effort to develop a series of degenerate PCR primers to these regions but the amplified sequences obtained did not demonstrate additional regions of homology to the *S. cerevisiae* *RAD9* or *DUN1* genes. We proposed to try direct amplification from human mammary cDNA and mammary carcinoma cDNA in order to prevent any bias against long messages or "unclonable" sequences that might not be represented in a cDNA library.

During year 3, amplification was performed on multiple human cDNA samples including normal mammary cells, breast carcinoma cell lines and ovarian cDNA. The resulting PCR products were cloned and sequenced. No sequences obtained provided evidence for additional regions of homology between the isolated sequence and the yeast *RAD9* or *DUN1* genes

respectively. Thus, the use of direct cDNA sources from either benign or malignant mammary cells did not result in isolation of novel human cDNAs for these checkpoint genes. During year 4 of the grant the human genome project has neared completion, searches of these resources using a variety of techniques has not identified human genes or cDNAs with significant homology (outside the BRCT domain) for *RAD9* and *DUN1*. Thus, these two genes may not have a direct homolog in the human genome, but their functions may be carried out by other types of proteins, e.g., p53 in the case of Dun1 and BRCA1 for Rad9.

c. Isolation of human *RAD21* cDNA.

We used different genetic screens including two-hybrid screens in yeast for human cDNAs in the DNA damage checkpoint and repair response. As part of those screens cDNAs encoding the human homolog of *S. pombe RAD21* and *S. cerevisiae RAD18* were isolated. The *RAD21* sequence has been previously reported in the literature although the human gene and protein has not been thoroughly characterized previously.

Technical Objective 2A – Checkpoint gene structure and expression in human breast cancer cell lines.

As accomplished during year 2 of this grant, RNA, DNA and protein were derived from eight human mammary derived cell lines, MCF10A, MCF7, MDA-MB-157, MDA-MD-231, MDA-MB-136, BT-20, HBL100 and SKBR-3 grown in culture under controlled conditions. Analysis of expression of *RAD21* reveals increased expression at the RNA level in breast cancer cell lines, specifically MDA-MB-436 and SK-BR-3 in comparison to the HMEC controls.

We then pursued the development of reagents in order to study the expression of human Rad21 in mammary cell lines and breast cancer samples. A polyclonal antibody was obtained towards the end of year 2. During year 3, we obtained a large stock of this anti-sera and obtained affinity purified antibody that is being used in immunohistochemistry and immunofluorescence experiments. We also isolated a monoclonal antisera for additional studies (eg, immunoprecipitation with polyclonal antisera followed by Western blotting with monoclonal antibody). Monoclonal antibody which recognizes the human Rad21 protein was obtained by immunization with a GST-Rad21 fusion protein. The monoclonal is functional in both Western blot and immunoprecipitation assays.

During year 3, we performed Western blots analysis of the cell lines listed above with the anti-Rad21 polyclonal antibody. Expression of Rad21 is variable in human breast cancer cell lines. In particular, the level of Rad21 protein is elevated in MCF-7 and SK-BR-3 cell lines in comparison to MCF10F cells. In contrast Rad21 protein is absent in the BT-20 cell line suggesting a possible mutational mechanism. These results provided a rationale for further analysis of Rad21 protein expression in human breast cancers with known levels of aneuploidy.

In order to accomplish this last goal, during year 4 we have collaborated with the Baylor Breast Cancer Center (Kent Osborne, Director). They have now tested the anti-Rad21 antibody on a pilot sample of breast cancer samples and optimized the protocol to

provide excellent detection by immunohistochemistry after antigen retrieval. This protocol is now being used to systematically determine the expression of Rad21 in breast cancer samples as a function of chromosome number or aneuploidy. These studies are continuing after the end of year 4.

Expression studies of human Rad21 in normal and checkpoint deficient cell lines after DNA damage were undertaken. *RAD21* mRNA is not up or down regulated in response to ionizing radiation. Western analysis revealed that after ionizing radiation there was no change in the major bands representing Rad21 in several cell types including the totally checkpoint deficient A-T cells. Thus, we did not see evidence for a change in phosphorylation or expression after ionizing radiation. However, some cell types demonstrated the production of a lower molecular weight band consistent with cleavage. Further analysis revealed that cells in the early stages of apoptosis demonstrated cleavage of the endogenous Rad21 protein. Induction of apoptosis in multiple human cell lines results in the early (4 hours post insult) generation of a 64 kD cleavage Rad21 product. Identity of this product is confirmed by recognition by affinity purified polyclonal and monoclonal antibody to human Rad21. This product is detected after induction of apoptosis by both DNA damaging agents (ionizing radiation and topoisomerase inhibitors) as well as non-DNA damaging agents (cycloheximide treatment and cytokine withdrawal). Induction of apoptosis is assayed by cleavage of the endogenous PARP protein and morphological changes consistent with apoptosis. In addition, equivalent doses of ionizing radiation in cells which are resistant to apoptosis do not generate this band; thus, it is not a simple byproduct of DNA damage. Addition of caspase inhibitors to the cells blocks the cleavage of Rad21 after an apoptotic signal. Given the role of rad21 in chromosome cohesion, the cleavage product may signal subsequent events of apoptosis including DNA degradation. Further evidence for signalling is provided by the finding that the Rad21 cleavage product is translocated to the cytoplasm after cleavage.

Technical Objective 2B – Structure and Expression of Putative G2 Checkpoint Genes in a Murine Model of Mammary Tumorigenesis.

As originally proposed, Dr. Dan Medina in the Department of Molecular and Cellular Biology at BCM has developed a number of murine cell lines and murine models of mammary tumorigenesis. During years 3 and 4 we have used these cell lines which represent different stages of tumorigenesis from normal through immortal to completely transformed as models of the mammary tumorigenic process. Expression of murine CDC34 and Rad21 protein and RNA were determined in these lines. We also examined expression of murine Rad21 and several other proteins which regulate Rad21 function (including separins) in these lines under different growth conditions and hormone exposure. We did not find any evidence for alterations in CDC34 protein or Rad21 protein in these lines or under these conditions despite a two fold increase in Rad21 RNA expression. However, there was a highly reproducible increase (5-10 fold) in separin protein expression upon steroid hormone exposure. This is an unexpected result and may have implications for the well-documented increase in breast cancer development due to increased steroid hormone exposure. Experiments to determine the impact on altered separin expression on genomic stability and aneuploidy are continuing at the current time.

Technical Objective 3 – Functional Consequences of Altered Structure or Expression of putative Human Checkpoint Genes on cell cycle regulation and genomic stability.

The finding that Rad21 is regulated during apoptosis (as opposed to DNA damage itself) is a novel finding. This has led to a new hypothesis that there may be a direct link between the development of aneuploidy (given Rad21's role in chromosome cohesion) and apoptosis. During year 4 we used our biochemical reagents to purify the cleaved fragment. The isolated peptides were then sequenced in order to determine the specific cleavage site within the protein. This site is unique from the previously identified cleavage that occurs at the end of mitosis. We have also identified that the cleavage is sensitive to the presence of a particular set of phosphatase inhibitors. Current experiments are underway to determine whether expression of either the full length or cleaved product in the cytoplasm will induce apoptosis. As noted in Technical Objective 2B the finding of altered separin expression after hormone exposure has led to experiments to determine if increased expression of separin proteins alters genomic stability in these lines.

Personnel Supported by this Award over the Term of the Grant

Sharon E. Plon, M.D, PhD - Assistant Professor

C. Key Research Accomplishments

- Extensive degenerate PCR cloning to obtain human homologs of *RAD9* and *DUN1* completed utilizing cDNA sources from both normal mammary cells and breast carcinoma cells.
- Polyclonal antibody to human Rad21 protein produced and affinity purified.
- Monoclonal antibody to human Rad21 protein produced.
- Determined expression of Rad21 protein assayed in human mammary and breast cancer cell lines.
- Development and optimization of technique to assay Rad21 expression in human breast cancers accomplished.
- Identification of Rad21 cleavage as an early step in apoptosis.
- Identification of Rad21 cleavage site after induction of apoptosis.

D. Reportable Outcomes:

- Results of this project presented at three meetings:
 - International Meeting on Forkhead/Winged Helix Proteins“ Analysis of *CHES1*, A Human Checkpoint Suppressor,” Scripps Institute, La Jolla, CA, November, 1998
 - Cold Spring Harbor Cell Cycle Meeting, May, 2000, Cold Spring Harbor New York (abstract attached).
 - DOD Era of Hope Meeting, June 2000, Atlanta GA.
- Monoclonal antibody to human Rad21 protein produced.
- Manuscript describing regulation of Rad21 during apoptosis is in preparation.
- DOD Concept, IDEA award and CDA award grant applications were selected for award to co-Investigator, Debananda Pati, to explore the newly identified link between apoptosis and chromosome cohesion.
- Two review articles on BRCA1 and BRCA2 analysis were written and the support of the CDA award acknowledged.

Plon, S.E. (1998). Screening and Clinical Implications for BRCA1 and BRCA2 Mutation Carriers. *J. Mammary Gland Biology and Neoplasia*. 3(4): 377-387

Kedar, I.M. and **Plon, S.E.** (2001) . “Counseling the at Risk Patient in the BRCA1/BRCA2 Era” in Obstetrics and Gynecology Clinics of North America. (Eds. Simpson, J.L. and Gregg, A.R.), *in press*.

E. Conclusions

The most challenging aspect of this project was the isolation of novel cDNAs encoding human homologs of yeast DNA damage response genes. Complementation of the yeast mutant *rad9* did not yield human cDNAs with significant homology. Major efforts to isolate cDNAs by degenerate PCR strategies for *RAD9* and *DUN1* during year 1 and year 2 were also not successful and analysis of the human genome sequence released recently suggests that these homologs may not exist. In contrast, two hybrid screens using known human DNA damage response/cell cycle genes did result in the isolation of human homologs of *RAD18* and *RAD21*. Thus, the focus over year 3 and 4 has been the characterization of the human Rad21 protein in mammalian cells and breast cancer cells.

The subsequent objectives focused on determination of whether cDNAs isolated in genetic screens are altered in expression or structure in breast cancers. As described in this report we do see variable expression of human Rad21 mRNA and protein in human breast cancer cell lines. This has led to development of immunohistochemistry techniques and ongoing experiments on primary human breast cancer samples with the Baylor Breast Care Center investigators. These studies will in particular look for a correlation between Rad21 expression and aneuploidy.

The results of Technical Objective 2 have been most surprising to date. We did not see alteration in *RAD21* mRNA or Rad21 phosphorylation in human cells exposed to DNA damage. However, we did detect specific cleavage of the protein. This has led to determination that induction of the apoptotic pathway (as opposed to DNA damage itself) induces specific cleavage of the human Rad21 cohesin protein. The biochemical characteristics of the cleavage have been identified and the cleavage site in the protein determined. This cleavage product may play a role in signalling subsequent events in apoptosis or result in aneuploidy in cells that survive the apoptotic response. In addition, analysis of murine models of tumorigenesis suggest that separin protein (which regulates Rad21 activity) expression may be hormone dependent and may have implications for the well-documented tumor promotion which results from hormone exposure.

Appendix 1 – Abstract from Cold Spring Harbor Laboratories – Cell Cycle Meeting

CLEAVAGE OF HUMAN Rad21 COHESIN PROTEIN: POTENTIAL ROLE IN EARLY APOPTOSIS**DEBANANDA PATI, Sharon E. Plon**

Department of Pediatrics, Baylor College of Medicine, Houston, TX

Sister chromatid cohesion during DNA replication plays a pivotal role for accurate chromosome segregation in eukaryotic cell cycle. Analysis of Rad21 function in fission yeast and *SCC1/MCD1* in budding yeast have demonstrated that it is required for appropriate chromosome segregation during normal mitotic cell cycles and double strand break repair after DNA damage. In budding yeast sister chromatid separation is promoted by the cleavage of the cohesin sub-unit Scc1 and may involve ubiquitin-mediated proteolysis of regulatory molecules. In a two-hybrid screen for potential targets of human Cdc34 (hCdc34) ubiquitin-conjugating enzyme, we have isolated human Rad21 (hRad21) as an hCdc34 interactor. Transfection studies in mammalian cells have indicated physical association of hCdc34 and hRad21 using co-immunoprecipitation experiments. Level of hRad21 was significantly enhanced in the presence of proteasome inhibitors, indicating the involvement of ubiquitin-mediated proteolysis. In a parallel set of studies to analyze the role of Rad21 in mammalian cells after DNA damage, we have identified a novel regulation of hRad21 protein in apoptosis. Induction of apoptosis in multiple human cell lines results in the early (4 hours post insult) generation of a 64 kDa cleavage hRad21 product. Although Rad21 is a nuclear protein the cleaved 64 kDa product is found in both nuclear and cytoplasmic fractions. Identity of this product is confirmed by recognition by affinity purified polyclonal and monoclonal antibody to hRad21. This product is detected after induction of apoptosis by both DNA damaging agents (ionizing radiation and topoisomerase inhibitors) as well as non-DNA damaging agents (cycloheximide treatment and cytokine withdrawal). In addition, equivalent doses of ionizing radiation in cells which are resistant to apoptosis do not generate this band; thus, it is not a simple byproduct of DNA damage. Given the role of Rad21 in chromosome cohesion, this cleavage product may signal subsequent events of apoptosis including DNA degradation. A role for Rad21 in apoptosis has been further strengthened by identification of a number of genes involved in apoptosis as interactors of hRad21 in a two-hybrid assay. In summary, ubiquitin-mediated proteolysis may play a role in the cleavage of hRad21 during metaphase-anaphase transition. In addition to previously described functions of Rad21 in chromosome segregation and DNA repair, cleavage of the protein is an early event in the apoptotic pathway. These results provide the framework to identify the physiologic role of hRad21 function in the apoptotic response of normal and malignant cells.

Appendix 2 – Abstract from DOD Era of Hope Meeting – 2000.

**CHARACTERIZATION OF THE HUMAN RAD21 COHESIN PROTEIN
AND DETECTION OF SPECIFIC CLEAVAGE EARLY IN APOPTOSIS**

Drs. Sharon E. Plon and Debananda Pati

Department of Pediatrics, Baylor College of Medicine, Houston, TX 77030

E-mail: splon@txccc.org

The goal of this project is to identify human homologs of yeast genes proven to play a role in the response to DNA damage. Isolation of these genes will then allow characterization of their expression and activity in both normal and malignant cells exposed to DNA damage. Our laboratory has employed a number of techniques to identify human homologs of these genes including yeast two hybrid screens with human cell cycle genes. We have identified the human homolog of the yeasts Rad21/*SCC1/MCD1* genes. Prior analysis of Rad21 function in fission yeast and *SCC1/MCD1* in budding yeast have demonstrated that it is required for double strand break repair after DNA damage and appropriate chromosome segregation during normal mitotic cell cycles.

We have now characterized the expression of human Rad21 RNA and protein in mammalian cells in response to DNA damage and in human breast cancer cell lines. Expression of Rad21 is variable in human breast cancer cell lines. In particular, the level of Rad21 protein is elevated in MCF-7 and SK-BR-3 cell lines in comparison to MCF10F cells. In contrast Rad21 protein is absent in the BT-20 cell line suggesting a possible mutational mechanism. These results provide a rationale for further analysis of Rad21 protein expression in human breast cancers with known levels of aneuploidy. Analysis of mammalian cells after DNA damage has identified a novel regulation of Rad21 protein in apoptosis. Induction of apoptosis in multiple human cell lines results in the early (4 hours post insult) generation of a 64 kD cleavage Rad21 product. Identity of this product is confirmed by recognition by affinity purified polyclonal and monoclonal antibody to human Rad21. This product is detected after induction of apoptosis by both DNA damaging agents (ionizing radiation and topoisomerase inhibitors) as well as non-DNA damaging agents (cycloheximide treatment and cytokine withdrawal). In addition, equivalent doses of ionizing radiation in cells which are resistant to apoptosis do not generate this band; thus, it is not a simple byproduct of DNA damage. Given the role of rad21 in chromosome cohesion, this cleavage product may signal subsequent events of apoptosis including DNA degradation. In summary, expression of the human cohesin protein Rad21 is altered in human breast cancer cell lines and in addition to previously described functions in chromosome segregation and DNA repair, cleavage of the protein is an early event in the apoptotic pathway. These results provide the framework to identify the importance of Rad21 function in the apoptotic response of breast cancer cells to treatment.

The U.S. Army Medical Research and Materiel Command under DAMD17-97-1-7284 and DAMD17-98-8281 supported this work.

Screening and Clinical Implications for *BRCA1* and *BRCA2* Mutation Carriers

Sharon E. Plon^{1,2}

In this article, we review the history of testing for mutations in breast cancer susceptibility genes and discuss the current state of testing for mutations in *BRCA1* and *BRCA2* in different clinical settings including at-risk individuals and cancer patients. The risk of breast cancer, other associated malignancies and prognosis in carriers of these mutations are reviewed. A final section includes discussion of current recommendations for surveillance and the need for further research to identify environmental and genetic factors which modify the risk of developing cancer in mutation carriers.

KEY WORDS: *BRCA1*; *BRCA2*; breast cancer; ovarian cancer; cancer susceptibility genes; mutation detection.

INTRODUCTION

The localization (1,2) and eventual cloning (3,4) of specific breast cancer susceptibility genes has led to enormous interest in the clinical application of this data from both the medical and lay communities. In this article we summarize the early and current uses of predictive testing for mutations in the *BRCA1* and *BRCA2* cancer susceptibility genes. We also review the cancer risks that can be attributed to these mutations and then describe some of the pressing research questions with regard to molecular testing, surveillance and prevention of cancer in these high-risk individuals.

The subject of mutational analysis for mutations in *BRCA1* and *BRCA2* includes a substantial literature with regard to the potential legal and ethical problems individuals facing testing must consider. This topic is beyond the scope of this review and has been recently reviewed by a number of authors (5,6). In addition, a

number of professional societies and advocacy groups have developed statements with regard to this topic (7,8). A review of some of the conflicts between these different policy statements has recently been published (9).

INITIAL SCREENING BY LINKAGE ANALYSIS

The localization of an early onset breast cancer gene to chromosome 17q21 was the initiating event in the use of DNA testing to clarify an individual's risk of developing breast cancer (1). A number of epidemiological studies had previously demonstrated that a family history of breast cancer was a major predisposing factor for breast cancer (10). Programs were developed that evaluated women at high risk of developing breast cancer based on significant family histories, adverse reproductive risk factors, adverse pathology on breast biopsy and multiple breast masses (11). However, decisions about risk of cancer were not based on a specific molecular diagnosis, and the models used to predict risk are not accurate in families segregating a dominant breast cancer susceptibility gene (11).

¹ Departments of Pediatrics, Molecular and Human Genetics, Texas Children's Cancer Center, Baylor College of Medicine, Houston, Texas.

² To whom correspondence should be addressed at Texas Children's Hospital MC3-3320, 6621 Fannin Street, Houston, Texas 77030. e-mail: splon@bcm.tmc.edu

sequencing) and is a major impediment to the clinical utility of mutational analysis. The high cost and relatively large pool of potential patients has led to exploration of a microarray or chip based technology for mutation detection in the *BRCA1* and *BRCA2* genes. But to date none of these methods are being offered on a clinical basis.

The initial experiences with full-scale scanning and sequencing analysis in clinical settings have been reported. *BRCA1* mutations were found in 16% of families of 194 affected individuals ascertained to have a positive family history who sought evaluations in a high-risk program (18). Shattuck-Eiden, *et al.*, analyzed the *BRCA1* gene by full sequencing in 918 individuals seeking mutational analysis in clinical centers (19). Overall mutations were found in only 13% of patients. Analysis of the individuals studied by both groups led to prediction of characteristics of patients in whom mutations are more or less likely to be identified. Not surprisingly, women with breast or ovarian cancer who had significant family histories of cancer were the most likely to be mutation carriers. For *BRCA1* analysis individuals with a personal or family history of ovarian cancer were more likely to test positive than those with a history of breast cancer. For breast cancer, a younger age of onset of the cancer in the proband or relative was associated with a greater likelihood of finding a mutation. The finding of *BRCA1* mutations in only 13–16% of subjects contrasts with the results of the Breast Cancer Linkage Consortium (BCLC)³ (17) where mutations were found in *BRCA1* in 64 of 180 (35%) families who met the criteria for the consortium. This difference is due to the large number of individuals seeking evaluation in the former studies who are from “high risk” families with substantially fewer cases of early onset breast cancer and ovarian cancer than required by the Consortium. Mutational analysis has also been performed on cohorts of early-onset breast cancer patients independent of family history. In studies of non-Ashkenazi American breast cancer patients under age 40, specific *BRCA1* mutations are found in approximately 7% (20). Addition of *BRCA2* analysis may only increase this estimate to approximately 10% of cancer patients under age 40 who have a detectable mutation (21).

³ Abbreviations: Breast Cancer Linkage Consortium (BCLC).

CLINICAL PROGRAMS FOR RISK ASSESSMENT AND MOLECULAR DIAGNOSTICS

The high frequency of breast cancer (both hereditary and non-hereditary in origin) has led to the development of a number of different clinical screening programs for risk assessment and molecular diagnostics. The majority of these programs are part of ongoing research studies designed to determine the impact of testing for cancer susceptibility. The need for thorough counseling before and after testing as well as a detailed informed consent process must be emphasized.

At risk individuals from high-risk families. Analysis of molecular diagnostic testing strategies have been most intensive for women with a significant family history of breast cancer who have not yet developed cancer themselves (Fig. 1). Beginning with at risk members of families used in the original studies to identify linkage, investigations were initiated to determine a number of parameters including: interest in testing, likelihood of finding an informative mutation, psychological impact of testing, impact of testing on medical surveillance, and interest in or use of prophylactic surgery.

In initial studies, at-risk women who were offered the theoretical possibility of testing demonstrated very high interest (22). In subsequent studies where testing was actually offered variable interest was observed. The variability is partially due to the way in which

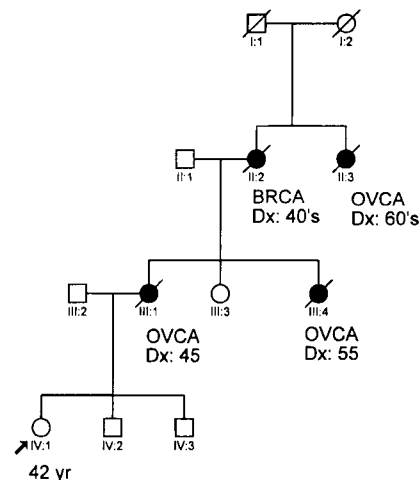

Fig. 1. Example of a pedigree from a 42-year-old woman (arrow-IV:1) seeking evaluation for *BRCA1* and *BRCA2* mutations in a Cancer Genetics clinic. Type of cancer and age of diagnosis (Dx) if known or whether pre- or post-menopausal are indicated. BRCA = breast cancer; OVCA = ovarian cancer; UL = unilateral.

test results and the high mobility of families within the United States.

Given the limitations of initial testing of affected relatives, some clinical programs offer testing to at-risk individuals even if a sample from an affected relative is not available. A positive test with a clearly deleterious mutation would be informative and potentially would allow the individual to make additional decisions with regard surveillance and surgery. In addition, asymptomatic relatives of that individual could be tested for the presence of the deleterious mutation. The caveat to this approach is that a negative *BRCA1* and *BRCA2* analysis does not substantially decrease the individual's risk of developing cancer. Substantial pre-test counseling is required to ensure that the patient does not misunderstand a negative test as lowering their risk of developing cancer. In addition, it must be explained clearly to the patient that the probability of finding a mutation is often <10%, before the expense and difficulty of molecular testing are undertaken.

Populations with recurring mutations. As outlined above, the presence of "private" mutations and the high complexity and cost of mutational analysis has primarily limited the use of *BRCA1* and *BRCA2* mutation testing to women with very significant family histories. Such analysis of families led to the discovery that three particular mutations (185delAG and 5382insC in *BRCA1* and 6174delT in *BRCA2*) occur at the very high frequency of one in 40 in the Ashkenazi Jewish population (28–30). Within Israel, extensive testing for all three mutations of Ashkenazi cancer patients has been performed and resulted in positive testing in nearly 30% of early-onset breast cancer patients (31) and 45% of ovarian cancer patients (32).

The relative simplicity of mutational analysis and the high frequency of these mutations has led to investigation of population-based testing (33). In one study after the discovery of the 185delAG mutation, 90% of 309 Ashkenazi individuals who chose to attend an educational session elected to have mutation testing performed. This group included both individuals with a positive family history of cancer and those without. Mutation analysis in this population (33), along with other studies (34), revealed that mutation carriers often have a family history of breast or ovarian cancer, but it may be much more limited (e.g. only postmenopausal breast cancer) than the BCLC high risk families.

Although population based testing is not being performed outside of research settings, overall, a substantial percentage of women undergoing mutational analysis for *BRCA1* and *BRCA2* mutations in the

United States are Ashkenazi Jewish. For example in the analysis by Couch, *et al.*, 10% of 263 breast cancer patients and families were Ashkenazi (18). However, not all breast cancers in highly affected Ashkenazi Jewish families can be attributed to these three high frequency mutations (35). Other "private" mutations have been identified, and, for a number of families, the dominant gene in the family remains unknown. This latter group of families may be very useful in identification of additional breast cancer susceptibility genes (36). Again, because not all families have one of the three known mutations it is still prudent to perform mutational analysis on an affected relative before testing at risk individuals in Ashkenazi families. However, given the high frequency and greater simplicity of mutation testing for these specific mutations in families where no samples are available from affected individuals analysis for the recurring mutations in at-risk individuals may be indicated.

Subsequent to the finding of the Ashkenazi mutations, recurring mutations in other populations have been identified including mutations in a number of different European and Icelandic populations (35). Within these populations, molecular testing based specifically on these mutations is being developed.

Cancer patients. Although the initial focus of screening programs was on at risk individuals, breast or ovarian cancer survivors seek mutational analysis to determine their risk of second malignancy and the probability of passing a predisposition on to their offspring. The analysis of the BCLC families revealed a 60% risk of a second breast cancer and a 38% risk of ovarian cancer by age 60 in a woman with a *BRCA1* mutation and breast cancer (37). For these individuals analysis is begun by testing their constitutional DNA directly for mutations.

THE RISK OF DEVELOPING CANCER FOR MUTATION CARRIERS

The primary clinical reason for undertaking *BRCA1* and *BRCA2* testing in at-risk individuals is the desire to define further their risk of developing cancer. Therefore, the genetic penetrance (or the likelihood of developing cancer if one has the mutation) of these specific mutations has been of intense research interest. Initial studies, especially of the BCLC families, suggested a very high age-related risk of cancer in carriers of *BRCA1* mutations with a nearly 90% risk of developing breast cancer and 40% risk of developing ovarian

developing ovarian cancer especially in families that carry *BRCA1* mutations (1). With regard to the likelihood of detecting mutations in *BRCA1* a family history of ovarian cancer is a much better indicator than a history of breast cancer or the total number of breast cancer cases in the family (17–19). Although initial studies suggested that there may not be an increased risk of ovarian cancer in *BRCA2* families, this analysis has been revised (Table I) (4). In particular, mutations found in a central region of the *BRCA2* gene including exon 11 (termed the OCR) convey a significantly increased risk of ovarian cancer compared with mutations in either the 5' or 3' regions of the gene (47). This region of *BRCA2* includes the 6174delT common mutation in the Ashkenazi Jewish population and explains the high rate of ovarian cancer associated with this mutation. The biologic basis of this difference is unknown, and the difference is not related to mutation type, because the majority of mutations both within and outside the OCR are truncating mutations.

Given the poor prognosis of women with ovarian cancer, the finding that these mutations also increase ovarian cancer risk is potentially more disturbing to patients than the risk of developing breast cancer. One analysis suggested that the prognosis of *BRCA1* mutation carriers who developed ovarian cancer was improved compared with non-mutation carriers (48). Several other groups have not found such a survival advantage (45) as reviewed by Lynch and Watson (49) when using a variety of methods to ascertain cases and controls. Analysis of larger number of ovarian cancer patients with mutations will be required to further clarify this area.

In addition to the clear occurrence of ovarian cancer, more recent studies have suggested that *BRCA1* and *BRCA2* mutations confer different risks of other malignancies. Initial analysis of colon cancer and prostate cancer in *BRCA1* families has demonstrated relative risks of four and three, respectively, for mutation carriers in the BCLC (50). These risks have not been confirmed in other large series, and there are no current recommendations for increased screening over that recommended for the general population (51). Ashkenazi Jewish individuals with pancreatic cancer are significantly more likely to carry the 6174delT mutation in *BRCA2* than the general Ashkenazi population with an odds ratio of 8.3 (95% C.I. 2.2–23) (52). The increase in pancreatic cancer has not yet been confirmed in other studies but *BRCA2* was initially cloned partially based on a homozygous deletion of that gene in a pancreatic cancer (53). As is the case with ovarian

cancer, knowledge of an increased risk of pancreatic cancer is likely to be extremely troubling to individuals seeking risk assessment. Subsequent analysis of larger cohorts of mutation carriers will help clarify the risk of these malignancies and may expose additional cancer risks.

SURVEILLANCE AND TREATMENT GUIDELINES

One goal of *BRCA1* and *BRCA2* mutation testing is the identification of high-risk women who can be targeted for early surveillance and potentially also for prevention strategies. A number of surveillance guidelines have been used by different centers including early use of mammograms and screening for ovarian cancer. A panel of experts convened by The National Human Genome Research Institute published surveillance guidelines in 1997 (Table II) (51). As discussed by the authors, there is little data that clearly demonstrates a decrease in either morbidity or mortality for women who undergo intensive screening. However, there is a general consensus that increased surveillance should be offered to all women who are known carriers of *BRCA1* and *BRCA2* mutations or who are at substantial risk to carry such a mutation. The finding that the *BRCA1* and *BRCA2* proteins may play a role in DNA repair has led to concern about a potential increase in radiation induced tumors with frequent mammograms. In a recent study of young Ashkenazi Jewish women breast cancer patients Rabson, *et al.* (54) examined ipsilateral breast cancer recurrence in women treated by lumpectomy with radiation therapy. It is reassuring that there was no significant difference in recurrence in the irradiated breast between mutation carriers and non-carriers.

Much more controversial is the question of either chemoprevention or prophylactic surgery for these at

Table II. Recommended Surveillance Guidelines for High Carriers of *BRCA1* and *BRCA2* Mutations^a

Examination	Timing
Breast self-exam	monthly
Clinical breast exam	q6–12 months beginning at age 25–35
Mammography	q6–12 months beginning at age 25–35
Serum CA125	q6–12 months beginning at age 25–35
Transvaginal ultrasound	q6–12 months beginning at age 25–35

^a Data taken from Burke 1997 (51).

women carrying one of the recurrent mutations (61). Analysis of a large cohort of mutation carriers is necessary to determine the impact of reproductive factors, hormone therapy and other lifestyle choices on cancer risk. The creation of the National Cancer Institute Cancer Genetics Network should facilitate these types of studies which require large numbers of mutation carriers. One of the first analyses specifically examining breast cancer risk in mutation carriers has reported a statistically significant decrease in breast cancer development with cigarette smoking (62). An odds ratio of 0.46 for carriers with more than a four pack-year history compared to non-smokers was found. The mechanism of this protection is unclear but may be related to anti-estrogenic activity in cigarette smoke.

In addition to environmental factors, studies to determine whether specific modifier genes alter the risk are underway to identify the genetic components that alter cancer susceptibility. One example is the finding that certain rare alleles of the *HRAS1* locus are associated with an increase risk of ovarian cancer in *BRCA1* mutation carriers (63). Recently, the length of a CAG repeat in the androgen receptor gene has been associated with the age of onset of breast cancer in *BRCA1* carriers. Women with at least one long repeat have significantly earlier onset than those with two shorter alleles (64).

Finally, for the at risk women who enter these studies, better definition of what modifies the risk of malignancy will result in improved counseling about their individual risk and the potential to minimize the risk of cancer that is substantially elevated due to the presence of a mutation in *BRCA1* or *BRCA2*.

ACKNOWLEDGMENTS

The author acknowledges support from the Susan G. Komen Breast Cancer Foundation and the Department of Defense DAMD17-97-7284.

REFERENCES

1. J. M. Hall, M. K. Lee, B. Newman, J. E. Morrow, L. A. Anderson, B. Huey, and M. C. King (1990). Linkage of early-onset familial breast cancer to chromosome 17q21. *Science* **250**:1684-1689.
2. R. Wooster, S. Neuhausen, J. Manigion, Y. Quirk, D. Ford, N. Collins, and K. Nguyen (1994). Localisation of a breast cancer susceptibility gene (*BRCA2*) to chromosome 13q by genetic linkage analysis. *Science* **265**:2088-2090.
3. Y. Miki, J. Swensen, D. Schattuck-Eidens, P. A. Futreal, K. Harshman, S. Tavtigian, Q. Y. Liu, C. Cochran, L. M. Bennett, W. Ding, R. Bell, J. Rosenthal, C. Hussey, T. Tran, H. McClure, C. Frye, T. Hattier, R. Phelps, A. Haugen-Strano, H. Katcher, K. Yakumo, Z. Gholami, D. Shaffer, S. Stone, S. Bayer, C. Wray, R. Borgden, P. Dayananth, J. Ward, P. Tonin, S. Narod, P. Bristow, F. Norris, L. Helvering, P. Morrison, P. Rosetteck, M. Lai, J. C. Barrett, C. Lewis, S. Neuhausen, L. Canon-Albright, D. Goldgar, R. Wiseman, A. Kamb, and M. H. Skolnick (1994). Isolation of *BRCA1*, the 17q-linked breast and ovarian cancer susceptibility gene. *Science* **266**:66-71.
4. R. Wooster, G. Bignell, J. Lancaster, S. Swift, S. Seal, J. Mangion, N. Collins, S. Gregory, C. Gumbs, G. Micklem, R. Barfoot, R. Hamoudi, S. Patel, C. Rice, P. Biggs, Y. Hashim, A. Smith, F. Connor, A. Arason, J. Gudmundsson, D. Ficenec, D. Kelsell, D. Ford, P. Tonin, D. T. Bishop, N. K. Spurr, B. A. J. Ponder, R. Eeles, J. Peto, P. Devilee, C. Cornelisse, H. Lynch, S. Narod, G. Lenoir, V. Egilsson, R. B. Barkardottir, D. F. Easton, D. R. Bentley, P. A. Futreal, A. Ashworth, and M. R. Stratton (1995). Identification of the breast cancer susceptibility gene *BRCA2*. *Nature* **378**:789-792.
5. M. A. Rothstein (1995). Genetic testing: employability, insurability, and health reform. *J. Natl. Cancer Inst. Monogr.* **17**:87-90.
6. K. Rothenberg, B. Fuller, M. Rothstein, T. Duster, M. J. E. Kahn, R. Cunningham, B. Fine, K. Hudson, M. C. King, P. Murphy, G. Swergold, and F. Collins (1997). Genetic information and the workplace: Legislative approaches and policy challenges. *Science* **275**:1755-1757.
7. Statement of the American Society of Human Genetics on genetic testing for breast and ovarian cancer predisposition (1994). *Am. J. Hum. Genet.* **55**:I-IV.
8. Statement of the American Society of Clinical Oncology: Genetic testing for cancer susceptibility. Adopted on February 20, 1996 (1996). *J. Clin. Oncol.* **14**:1730-1736.
9. E. Kodish, G. L. Wiesner, M. Mehlman, and T. Murray (1998). Genetic testing for cancer risk. How to reconcile the conflicts. *J.A.M.A.* **279**:179-181.
10. H. T. Lynch, J. N. Marcus, P. Watson, and J. Lynch (1991). Familial breast cancer, family cancer syndromes, and predisposition to breast neoplasia. In K. I. Bland and E. M. I. Copeland (eds.), *The Breast: Comprehensive Management of Benign and Malignant Diseases*, W. B. Saunders Co., New York, pp. 262-291.
11. M. H. Gail, L. A. Brinton, D. P. Byar, D. K. Corle, S. B. Green, C. Schairer, and J. J. Mulvihill (1989). Projecting individualized probabilities of developing breast cancer for white females who are being examined annually. *J. Natl. Cancer Inst.* **81**:1879-1886.
12. P. M. Conneally, (1990). Huntington disease. In A. E. H. Emery and D. L. Rimoim (eds.), *Principles and Practice of Medical Genetics*, Churchill Livingstone, Edinburgh, pp. 373-382.
13. S. A. Narod, D. Ford, P. Devilee, R. B. Barkardottir, H. T. Lynch, S. A. Smith, B. A. J. Ponder, B. L. Weber, J. E. Garber, J. M. Birch, R. S. Cornelis, D. P. Kelsell, N. K. Spurr, E. Smyth, N. Haites, H. Sobol, Y. J. Bignon, J. Chang-Claude, U. Hamann, A. Lindblom, A. Borg, M. S. Piver, H. H. Gallion, J. P. Struewing, A. Whittemore, P. Tonin, D. E. Goldgar, D. F. Easton, and Breast Cancer Linkage Consortium (1995). An evaluation of genetic heterogeneity in 145 breast-ovarian cancer families. *Am. J. Hum. Genet.* **56**:254-264.
14. M. Durner, D. A. Greenberg, and S. E. Hodge (1996). Phenocopies versus genetic heterogeneity: Can we use phenocopy frequencies in linkage analysis to compensate for heterogeneity? *Hum. Hered.* **46**:265-273.
15. B. B. Biasecker, M. Boehnke, K. Calzone, D. S. Markel, J. E. Gerber, F. S. Collins, and B. L. Weber (1993). Genetic

- T. Peretz, and E. Friedman (1997). Directly derived penetrance estimates for the founder BRCA1/BRCA2 mutations in Jews: The Israeli consortium on hereditary breast cancer. *Am. J. Hum. Genet.* **61**:A72.
41. P. Tonin, B. Weber, K. Offit, F. Couch, T. R. Rebbeck, S. Neuhausen, A. K. Godwin, M. Daly, J. Wagner-Costalos, D. Berman, G. Grana, E. Fox, M. F. Kane, R. D. Kolodner, M. Krainer, D. A. Haber, J. P. Struewing, E. Warner, B. Rosen, C. Lerman, B. Peshkin, L. Norton, O. Serova, W. D. Foulkes, and J. E. Garber (1996). Frequency of recurrent BRCA1 and BRCA2 mutations in Ashkenazi Jewish breast cancer families. *Nat. Med.* **2**:1179–1183.
 42. J. N. Marcus, P. Watson, D. L. Page, S. A. Narod, G. M. Lenoir, P. Tonin, L. Linder-Stephenson, G. Salerno, T. A. Conway, and H. T. Lynch (1996). Hereditary breast cancer. Pathobiology, prognosis, and BRCA1 and BRCA2 gene linkage. *Cancer* **77**:697–709.
 43. J. N. Marcus, D. L. Page, P. Watson, S. A. Narod, G. M. Lenoir, and H. T. Lynch (1997). BRCA1 and BRCA2 hereditary breast carcinoma phenotypes. *Cancer* **80**:543–556.
 44. L. C. Verhoog, C. T. M. Brekelmans, C. Seynaeve, L. M. C. van den Bosch, G. Dahmen, A. N. van Geel, M. M. A. Tilanus-Linthorst, C. C. M. Bartels, A. Wagner, A. van den Ouweland, P. Devilee, E. J. Meijers-Heijboer, and J. G. M. Klijn (1998). Survival and tumour characteristics of breast-cancer patients with germline mutations of BRCA1. *Lancet* **351**:316–321.
 45. O. T. Johannsson, J. Ranstam, A. Borg, and H. Olsson (1998). Survival of BRCA1 breast and ovarian cancer patients: A population-based study from southern Sweden. *J. Clin. Oncol.* **16**:397–404.
 46. P. Watson, J. N. Marcus, and H. T. Lynch (1998). Prognosis of BRCA1 hereditary breast cancer. *Lancet* **351**:304–305.
 47. S. A. Gayther, J. Mangion, P. Russell, S. Seal, R. Barfoot, B. A. Ponder, M. R. Stratton, and D. Easton (1997). Variation of risks of breast and ovarian cancer associated with different germline mutations of the BRCA2 gene. *Nat. Genet.* **15**:103–105.
 48. S. C. Rubin, I. Benjamin, K. Behbakht, H. Takahashi, M. A. Morgan, V. A. LiVolsi, A. Berchuck, M. G. Muto, J. E. Garber, B. L. Weber, H. T. Lynch, and J. Boyd (1996). Clinical and pathological features of ovarian cancer in women with germline mutations of BRCA1. *N. Engl. J. Med.* **335**:1413–1416.
 49. H. T. Lynch and P. Watson (1998). BRCA1, pathology, and survival. *J. Clin. Oncol.* **16**:395–396.
 50. D. Ford, D. F. Easton, D. T. Bishop, S. A. Narod, and D. E. Goldgar (1994). Risks of cancer in BRCA1-mutations carriers. Breast Cancer Linkage Consortium. *Lancet* **343**:692–695.
 51. W. Burke, M. Daly, J. Garber, J. Botkin, M. J. E. Kahn, P. Lynch, A. McTiernan, K. Offit, J. Perlman, G. Petersen, E. Thomson, and C. Varricchio (1997). Recommendations for follow-up care of individuals with an inherited predisposition to cancer: II. BRCA1 and BRCA2. *J.A.M.A.* **277**:997–1003.
 52. H. Ozelik, B. Schmocker, N. Di Nicola, X. H. Shi, B. Langer, M. Moore, B. R. Taylor, S. A. Narod, G. Darlington, I. L. Andrulis, S. Gallinger, and M. Redston (1997). Germline BRCA2 6174delT mutations in Ashkenazi Jewish pancreatic cancer patients. *Nat. Genet.* **16**:17–18.
 53. M. Schutte, L. T. da Costa, S. A. Hahn, C. Moskaluk, A. T. Hoque, E. Rozenblum, C. L. Weinstein, M. Bittner, P. S. Meltzer, and J. M. Trent (1995). Identification by representational difference analysis of a homozygous deletion in pancreatic carcinoma that lies within the BRCA2 region. *Proc. Natl. Acad. Sci. U. S. A.* **92**:5950–5954.
 54. M. Robson, T. Gilewski, B. Haas, D. Levin, P. Borgen, P. Rajan, Y. Hirschaut, P. Pressman, P. P. Rosen, M. L. Lesser, L. Norton, and K. Offit (1998). BRCA-Associated Breast Cancer in Young Women. *J. Clin. Oncol.* **16**:1642–1649.
 55. NIH Consensus Development Panel on Ovarian Cancer (1995). Ovarian cancer. Screening, treatment, and follow-up. *J.A.M.A.* **273**:491–497.
 56. J. P. Struewing, P. Watson, D. F. Easton, B. A. J. Ponder, H. T. Lynch, and M. A. Tucker (1995). Prophylactic oophorectomy in inherited breast/ovarian cancer families. *J. Natl. Cancer Inst. Monogr.* **17**:33–35.
 57. M. S. Piver and C. Wong (1998). Role of prophylactic surgery for women with genetic predisposition to cancer. *Clin. Obstet. Gynecol.* **41**:215–224.
 58. L. Hartmann, R. Jenkins, D. Schaid, and P. Yang (1997). Prophylactic mastectomy (PM): Preliminary retrospective cohort analysis. *Am. Assoc. Cancer Res.* **38**:A168.
 59. D. Schrag, K. M. Kuntz, J. E. Garber, and J. C. Weeks (1997). Decision analysis—Effects of prophylactic mastectomy and oophorectomy on life expectancy among women with BRCA1 or BRCA2 mutations. *N. Engl. J. Med.* **336**:1465–1471.
 60. V. R. Grann, K. S. Panageas, W. Whang, K. H. Antman, and A. I. Neugut (1998). Decision analysis of prophylactic mastectomy and oophorectomy in BRCA1-positive or BRCA2-positive patients. *J. Clin. Oncol.* **16**:979–985.
 61. G. Ursin, B. E. Henderson, R. W. Haile, M. C. Pike, N. Zhou, A. Diep, and L. Bernstein (1997). Does oral contraceptive use increase the risk of breast cancer in women with BRCA1/BRCA2 mutations more than in other women? *Cancer Res.* **57**:3678–3681.
 62. J. S. Brunet, P. Ghadirian, T. R. Rebbeck, C. Lerman, J. E. Garber, P. N. Tonin, J. Abrahamson, W. D. Foulkes, M. Daly, J. Wagner-Costalos, A. K. Godwin, O. I. Olopade, R. Moslehi, A. Liede, P. A. Futreal, B. L. Weber, G. M. Lenoir, H. T. Lynch, and S. A. Narod (1998). Effect of smoking on breast cancer carriers of mutant BRCA1 or BRCA2 genes. *J. Natl. Cancer Inst.* **90**:761.
 63. C. M. Phelan, T. R. Rebbeck, B. L. Weber, P. Devilee, M. H. Ruttledge, H. T. Lynch, G. M. Lenoir, M. R. Stratton, D. F. Easton, B. A. J. Ponder, L. Cannon-Albright, C. Larsson, D. E. Goldgar, and S. A. Narod (1996). Ovarian cancer risk in BRCA1 carriers is modified by the HRAS1 variable number of tandem repeat (VNTR) locus. *Nat. Genet.* **12**:309–311.
 64. T. R. Rebbeck, P.W. Kantoff, K. Krithivas, S.A. Narod, A.K. Godwin, M. B. Kaly, J. E. Garber, B. L. Weber, and M. A. Brown (1998). Modification of breast cancer risk in BRCA1 mutation carriers by the androgen receptor CAG repeat polymorphism. *Am. Assoc. Cancer Res.* **39**:A366.