



Synthesis of Energetic Polyester Thermoplastic Homopolymers and Energetic Thermoplastic Elastomers Formed Therefrom

G. Ampleman
DREV, Canada

S. Brochu
M. Desjardins
BCR Polysyntech Inc.

DISTRIBUTION STATEMENT A
Approved for Public Release
Distribution Unlimited

**Defence R&D Canada
Defence Research Establishment Valcartier**

Technical Report
DREV TR 2001-175
November 2001



National
Defence

Défense
nationale

Canada

20011205 041

SYNTHESIS OF ENERGETIC POLYESTER THERMOPLASTIC HOMOPOLYMERS AND ENERGETIC THERMOPLASTIC ELASTOMERS FORMED THEREFROM

G. Ampleman
DREV

S. Brochu
BCR Polysyntech Inc.

M. Desjardins
BCR Polysyntech Inc.

Defence Research Establishment Valcartier

Technical Report

DREV TR 2001-175

2001-11-01

Author

Guy Ampleman

G. Ampleman

Approved by

Pierre Lessard

Pierre Lessard

Acting Head/ Emerging Energetic Materials Section

Approved for release by

Pierre Lessard

Pierre Lessard

Acting Head/ Emerging Energetic Materials Section

[Enter standard clause here]

© Her Majesty the Queen as represented by the Minister of National Defence, 2001

© Sa majesté la reine, représentée par le ministre de la Défense nationale, 2001

CLASSIFICATION / DESIGNATION
WARNING TERM

Abstract

For many years, DREV has been involved in the synthesis of energetic thermoplastic elastomers (ETPEs) based on linear glycidyl azide polymer (GAP). These polymers are physically-crosslinked rubbery materials that can be melted, dissolved or recycled and could provide a new generation of binders. Since ETPEs are recyclable, disposal of the formulations at the end of their life cycle will be less problematic. Work at DREV led to the preparation of a new thermoplastic segment. The polymerization of α -bromomethyl- α -methyl- β -propiolactone (BMMPL) or α -chloromethyl- α -methyl- β -propiolactone (CMMPL) yielded thermoplastic homopolymers that upon azidation led to a novel energetic thermoplastic polyester: poly (α -azidomethyl- α -methyl- β -propiolactone) (PAMMPL). An energetic copolyether-ester thermoplastic elastomer was prepared by using glycidyl azide polymer as a macroinitiator for the polymerization of BMMPL or CMMPL. The azidation of the resulting copolyether-ester yielded an energetic thermoplastic elastomer that melted at 80-85°C. Polymerization of the α -dibromomethyl- β -propiolactone (DBMPL) resulted in a polymer which upon azidation yielded a new energetic polymer that can be used as a binder or into an energetic thermoplastic elastomer synthesis. This report describes mainly the synthesis and the characterization of these new ETPEs.

Résumé

Pendant plusieurs années, le CRDV a participé à la synthèse de thermoplastiques élastomères énergétiques (TPEE) basés sur le polyazoture de glycidyle linéaire. Ces polymères sont des caoutchoucs réticulés physiquement qui peuvent être fondus ou dissous, recyclés et peuvent représenter une nouvelle génération de liants. Comme les TPEE sont recyclables, l'élimination de ces compositions à la fin de leur cycle de vie sera moins problématique. Le travail au CRDV a mené à la préparation d'un nouveau segment thermoplastique. La polymérisation de l' α -bromométhyl- α -méthyl- β -propiolactone (BMMPL) ou de l' α -chlorométhyl- α -méthyl- β -propiolactone (CMMPL) a produit des homopolymères thermoplastiques qui, une fois azotés, ont permis d'obtenir un nouveau polyester thermoplastique énergétique: le poly (α -azidométhyl- α -méthyl- β -propiolactone) (PAMMPL). Un copolyéther-ester énergétique thermoplastique élastomère a été préparé en utilisant le polyazoture de glycidyle comme macroinitiateur pour la polymérisation de la BMMPL ou de la CMMPL. L'azotation du copolyéther-ester résultant a permis d'obtenir un thermoplastique élastomère énergétique qui a fondu à 80-85°C. La polymérisation de l' α -dibromométhyl- β -propiolactone (DBMPL) a produit un polymère qui, après azotation, a permis d'obtenir un nouveau polymère énergétique qui peut être utilisé comme liant ou dans la synthèse de thermoplastiques élastomères énergétiques. Ce rapport décrit principalement la synthèse et la caractérisation de ces nouveaux TPEE.

This page intentionally left blank.

Executive summary

High-energy solid compositions, such as propellants, plastic-bonded explosives or the like, are usually prepared by combining a variety of materials including oxidizers, binders, plasticizers and a curing agent. Many energetic binders are available for use in the preparation of these high-energy compositions. Usually, these binders are obtained by a curing reaction involving the use of isocyanates and polyhydroxyl energetic or non-energetic prepolymers. Dihydroxyl terminated energetic polymers such as glycidyl azide polymer (GAP) serve as energetic binders and are reacted with a curing agent to form a chemically crosslinked matrix in low smoke propellant formulations and in insensitive cast cured plastic-bonded explosives (PBXs).

For composite explosives, the use of these thermoset binders leads to plastic bounded explosives which are chemically crosslinked and not recyclable. Moreover, the existing melt cast facilities are not suitable for these cast-cured PBX and the curing reaction involves by definition a pot-life. The mixture must be cast before the binder is completely crosslinked in the mixer. An elegant way to formulate PBXs in available melt cast facilities is to use thermoplastic elastomers. The use of thermoplastic elastomers (TPEs) avoids a process that involves curing reactions and hence has no pot life and leads to recyclable PBXs. Furthermore, it would be more desirable to use energetic thermoplastic elastomers because replacing explosives by energetic binders in the composition results in a lesser loss of energy compared to using non-energetic binders.

For years, researchers have tried to synthesize ETPEs melting between 80 °C and 100°C to replace TNT in melt cast compositions. At DREV, it was decided to develop polyesters to achieve that goal since these are usually biodegradable. Having this in mind, polymerization of α -bromomethyl- α -methyl- β -propiolactone (BMMPL) or α -chloromethyl- α -methyl- β -propiolactone (CMMPL) yielded a thermoplastic homopolymer that upon azidation led to a novel energetic thermoplastic polyester: poly(α -azidomethyl- α -methyl- β -propiolactone) that melted at 80-85°C. An energetic copolyether-ester thermoplastic elastomer was obtained by using GAP as a macroinitiator to initiate the polymerization of BMMPL or CMMPL. The azidation of the resulting copolyether-ester yielded an energetic thermoplastic elastomer that melted at 80-85°C. To investigate a structure more energetic, α -dibromomethyl- β -propiolactone (DBMPL) was also polymerized. The resulting polymer was reacted with sodium azide in dimethyl formamide to yield new energetic polyester that can be used as a binder or into an energetic thermoplastic elastomer synthesis. This report describes mainly the synthesis and the characterization of these new ETPEs.

Ampleman, G., Brochu, S., Desjardins, M., 2001. Synthesis of Energetic Polyester Thermoplastic Homopolymers and Energetic Thermoplastic Elastomers Formed Therefrom. DREV TR 2001-175 Defence Research Establishment Valcartier.

Sommaire

Les compositions solides à haute énergie, comme les propergols, les explosifs plastiques et autres composés du genre sont généralement préparés en combinant une variété de matériaux incluant des oxydants, des liants, des plastifiants et un agent de cuisson. Il existe plusieurs liants énergétiques pour la préparation de ces compositions énergétiques. Généralement, ces liants sont obtenus par cuisson impliquant des isocyanates et des prépolymères polyhydroxylés énergétiques ou non énergétiques. Les polymères énergétiques dihydroxylés, comme le polyazoture de glycidyle (PAG) servent de liants énergétiques et réagissent avec un agent de cuisson pour former une matrice réticulée chimiquement dans les compositions de propergols sans fumée et d'explosifs plastiques à risques atténués de type coulés-cuits (PBX).

Pour ces explosifs composites, l'utilisation des liants thermocuits produit des explosifs qui sont chimiquement liés et non recyclables. Les malaxeurs existants pour la fabrication des explosifs coulés-fondus ne sont pas appropriés pour ces explosifs coulés-cuits et la réaction de cuisson implique par définition un point de gel. Les mélanges doivent être coulés avant que le liant ne soit complètement réticulé dans le malaxeur. Une façon élégante de formuler les PBX dans les malaxeurs existants d'explosifs coulés-fondus est d'utiliser des thermoplastiques élastomères (TPE). L'utilisation de TPE permet d'éviter les procédés impliquant des réactions de cuisson et, par conséquent, n'a aucun point de gel et produit des PBX recyclables. De plus, il est préférable d'utiliser des thermoplastiques élastomères énergétiques parce que le remplacement d'explosifs par des liants énergétiques dans la composition occasionne une perte d'énergie moindre par rapport à l'utilisation de liants non énergétiques.

Pendant plusieurs années, les chercheurs ont tenté de préparer des TPEE fondant entre 80 °C et 100 °C pour remplacer le TNT dans les compositions d'explosifs coulés-fondus. Au CRDV, on a décidé de mettre au point des polyesters pour atteindre cet objectif, puisque ceux-ci sont généralement biodégradables. Cela en tête, la polymérisation de l' α -bromométhyl- α -méthyl- β -propiolactone (BMMPL) ou de l' α -chlorométhyl- α -méthyl- β -propiolactone (CMMPL) a permis d'obtenir un homopolymère thermoplastique qui, après azotation, a produit un nouveau polyester thermoplastique énergétique : le poly (α -azidométhyl- α -méthyl- β -propiolactone) qui fond à 80-85 °C. Un copolyéther-ester énergétique thermoplastique élastomère a été préparé en utilisant le PAG comme macroinitiateur pour la polymérisation de la BMMPL ou de la CMMPL. L'azotation du copolyéther-ester résultant a produit un thermoplastique élastomère énergétique qui a fondu à 80-85°C. Pour obtenir une structure plus énergétique, l' α -dibromométhyl- β -propiolactone (DBMPL) a aussi été polymérisée. Le polymère résultant a réagi avec l'azoture de sodium dans le diméthylformamide pour produire un nouveau polyester énergétique qui peut être utilisé comme liant ou dans la synthèse de thermoplastiques élastomères énergétiques. Ce rapport décrit principalement la synthèse et la caractérisation de ces nouveaux TPEEs.

Ampleman, G., Brochu, S., Desjardins, M., 2001. Synthesis of Energetic Polyester Thermoplastic Homopolymers and Energetic Thermoplastic Elastomers Formed Therefrom. DREV TR 2001-175 Defence Research Establishment Valcartier

Table of contents

Abstract	i
Executive summary	iii
Sommaire	iv
Table of contents	v
List of figures	vii
Acknowledgements	viii
1. Introduction	1
2. Theory	3
3. Experimental	6
3.1 Preparation of α -bromomethyl- α -methyl- β -propiolactone (BMMPL).....	8
3.1.1 Preparation of 2,2-dibromomethyl propyl acetate (DBMPAc)	8
3.1.2 Preparation of 2,2-dibromomethyl propionic acid (DBMPA)	9
3.1.3 Preparation of α -bromomethyl- α -methyl- β -propiolactone (BMMPL)10	
3.2 Preparation of α -chloromethyl- α -methyl- β -propiolactone (CMMPL).....	10
3.3 Poly(α -bromomethyl- α -methyl- β -propiolactone) (PBMMPL)	11
3.4 Poly(α -chloromethyl- α -methyl- β -propiolactone) (PCMMPL)	11
3.5 Poly(α -azidomethyl- α -methyl- β -propiolactone) (PAMMPL).....	11
3.6 Synthesis of the copolymer GAP 2000-PAMMPL	12
3.6.1 Copolymerization of GAP 2000 with PBMMPL	12
3.6.2 Azidation of the copolymer GAP 2000-PBMMPL	12
3.7 Synthesis of the copolymer GAP-PAMMPL with HMW GAP	13
3.7.1 Copolymerization of HMW GAP with PBMMPL	13
3.7.2 Azidation of the copolymer HMW GAP-PBMMPL	13
3.8 Synthesis of α -dibromomethyl- β -propiolactone (DBMPL)	14
3.8.1 Preparation of 3-bromo-2,2-dibromomethylpropyl acetate (BDBMPAc)	14

3.8.2	Preparation of 3-bromo-2,2-dibromomethyl propionic acid (BDBMPA)	14
3.8.3	Preparation of α -dibromomethyl- β -propiolactone (DBMPL)	14
3.9	Synthesis of α -dichloromethyl- β -propiolactone (DCMPL).....	14
3.9.1	Preparation of 3-chloro-2,2-dichloromethylpropyl acetate (CDCMPAc)	14
3.9.2	Preparation of 3-chloro-2,2-dichloromethyl propionic acid (CDCMPA)	15
3.9.3	Preparation of α -dichloromethyl- β -propiolactone (DCMPL).....	15
3.10	Synthesis of Poly- α -dibromomethyl- β -propiolactone) (PDBMPL)	15
3.11	Synthesis of poly(α -dichloromethyl- β -propiolactone) (PDCMPL).....	15
3.12	Synthesis of poly(α -diazidomethyl- β -propiolactone) (PDAMPL)	16
4.	Results and discussion.....	17
4.1	Preparation of the Propiolactones	17
4.2	Polymerization of Propiolactones	19
4.3	Copolymerization of Propiolactones with GAP	20
5.	Conclusion.....	22
6.	References	23
	List of symbols/abbreviations/acronyms/initialisms	26
	Glossary.....	28
	Distribution list (Internal).....	29
	Distribution list (External)	30

List of figures

Figure 1. Synthesis of α -bromomethyl- α -methyl- β -propiolactone	7
Figure 2. Synthesis of α -chloromethyl- α -methyl- β -propiolactone.....	7
Figure 3. Synthesis of α -dibromomethyl- β -propiolactone.....	8
Figure 4. Copolymerization of GAP with propiolactones followed by azidation.....	9

Acknowledgements

The authors would like to thank the National Sciences and Engineering Research Council of Canada for their financial support in the form of fellowships (Dr. S. Brochu). The Department of National Defence and especially the Defence Research Establishment Valcartier are gratefully acknowledged for providing materials, laboratories and funds for the contractors.

1. Introduction

High-energy solid compositions, such as propellants, plastic-bonded explosives or the like, are usually prepared by combining a variety of materials including oxidizers, binders, plasticizers and a curing agent. Many energetic binders are available for use in the preparation of these high-energy compositions. Usually, these binders are obtained by a curing reaction involving the use of isocyanates and polyhydroxyl energetic or non-energetic prepolymers. Dihydroxyl terminated telechelic energetic polymers such as glycidyl azide polymer (GAP), poly 3-nitratomethyl-3-methyloxetane (NIMMO) and poly glycidyl nitrate (GLYN) serve as energetic binders [1-2] and are reacted with a curing agent to form a chemically crosslinked matrix for ammonium nitrate in new insensitive low smoke propellant formulations, and for RDX in new insensitive plastic-bonded explosives [3-11]. To produce this chemically crosslinked matrix, a triol or a triisocyanate, or both, or a polymer having a functionality greater than two reacting with a diisocyanate, must be used to ensure the crosslinking [12-16]. In such systems, different mechanical properties of the binder can be obtained by adjusting the parameters of the curing reaction and the component concentrations, which results in varying the crosslink density of the matrix [17].

For composite explosives, the use of these thermoset binders leads to plastic bounded explosives (PBXs), which are chemically crosslinked and not recyclable. Moreover, the existing melt cast facilities are not suitable for cast-cured PBX and the curing reaction involves by definition a pot-life. This is a disadvantage since the formulators must cast the mixture before the binder is completely crosslinked in the mixer. An elegant way to formulate PBXs in available melt cast facilities is to use thermoplastic elastomers. The use of thermoplastic elastomers (TPEs) avoids a process that involves curing reactions and hence has no pot life and leads to recyclable PBXs. Furthermore, it would be more desirable to use energetic thermoplastic elastomers because replacing explosives by energetic binders in the composition results in a lesser loss of energy compared to using non-energetic binders. The limitation of this technology is that thermoplastic elastomers melting in the range of 80-100°C are needed in order to be processed in the existing melt-cast facilities and that those melting at higher temperatures are not suitable for this process.

For years, researchers have tried to synthesize energetic thermoplastic elastomers melting between 80 °C and 100°C. In 1987, Manser established that the polymerization of numerous oxetane monomers yielded energetic homopolymers that could be used as binders [18]. Among these oxetane polymers, Manser isolated BAMO, an energetic thermoplastic homopolymer that melts at 83°C. Until now BAMO was the only available energetic thermoplastic homopolymer. Wardle showed that energetic thermoplastic elastomers could be prepared directly in the mixer by block polymerization of BAMO with other oxetane polymers using an end capped technique [19]. He also showed that ABA triblocks or star thermoplastic elastomers could be obtained by polymerization of the BAMO monomers with other oxetanes monomers [20]. Although useful, all these energetic thermoplastic

elastomers must comprise BAMO as the hard segment. Since energetic thermoplastic elastomers are potential products to introduce in and prepare insensitive high-energy compositions, there is a need to develop new energetic thermoplastic homopolymers and energetic thermoplastic elastomers that melt at 80-85°C.

At DREV, it was decided to develop the synthesis of a polyester since these chemical groups are usually biodegradable. Having a thermoplastic elastomer in a formulation is very good since it gives a recyclable product but using a polyester in the structure would give a product that can be biodegraded leading to an environmental friendly polymer. Having this in mind, polymerization of α -bromomethyl- α -methyl- β -propiolactone (BMMPL) or α -chloromethyl- α -methyl- β -propiolactone (CMMPL) yielded a thermoplastic homopolymer that upon azidation led to a novel energetic thermoplastic polyester: poly (α -azidomethyl- α -methyl- β -propiolactone) (PAMMPL) that melted at 80-85°C. An energetic copolyether-ester thermoplastic elastomer was obtained by using glycidyl azide polymer as a macroinitiator to initiate the polymerization of BMMPL or CMMPL. The azidation of the resulting copolyether-ester yielded an energetic thermoplastic elastomer that melted at 80-85°C. To investigate a structure similar to BAMO, α -dibromomethyl- β -propiolactone (DBMPL) was also polymerized. The resulting polymer was reacted with sodium azide in dimethyl formamide to yield new energetic polyester that can be used as a binder or into an energetic thermoplastic elastomer synthesis. This paper describes mainly the synthesis and the characterization of these new ETPEs.

2. Theory

Thermoplastic elastomers are copolymers of type ABA, AB or (AB)_n, where A and B are respectively the hard segment and the soft segment [21]. Star shaped and grafted copolymers that include A and B blocks are also thermoplastic elastomers. The hard segment is capable of crystallization or association and gives the thermoplastic behaviour to the copolymer, whereas the soft segment gives the elastomeric behaviour to the copolymer. The thermoplastic behaviour is the result of crystalline domain formation by chain associations due to reversible interactions such as dipole-dipole interactions, hydrogen bonding, etc. In practice, at room temperature, a thermoplastic elastomer behaves like a rubber because it is crosslinked in the same fashion as a conventional elastomer, but with reversible physical crosslinks. Since the physical crosslinks are reversible, the thermoplastic elastomer (TPE) can be melted or dissolved in a solvent, so that the polymer can be mixed and processed with other components of, for example, a melt cast explosive. Depending on the processing technique used to prepare the gun or rocket propellant or the explosive formulation, steps such as cooling or evaporating the solvent will allow the TPE bonds to re-form to give the final material. This also means that an obsolete formulation containing a TPE could be melted or re-dissolved allowing the recovery of the ingredients. Therefore, using a TPE will lead to recyclable compositions of energetic materials. The molecular weight of the soft segment and the hard segment must be balanced to get good mechanical properties. Since it is very difficult to predict the mechanical properties of the thermoplastic elastomer, it is often challenging to find the perfect balance for the molecular weights of both segments.

Thermoplastic elastomer copolymers of type ABA are usually obtained by polymerization of a difunctional homopolymer B followed by the addition of monomers of the homopolymer A which is crystalline. To achieve this type of copolymerization, monomers of both types should have a similar reactivity and most of the time the polymerization is a living one. This technology leads to a copolymer of controlled structure with suitable adjustable mechanical properties. A good example of this type of polymerization is the preparation of the AMMO/BAMO ETPE. Since 3-azidomethyl-3-methyloxetane (AMMO) and bis 3,3-azidomethyloxetane (BAMO) are both oxetanes with similar reactivities, polymerization of type ABA is possible. Manser et al. prepared a wide variety of AMMO/BAMO copolymers of different molecular weights and mechanical properties by varying the monomer concentrations and the polymerization parameters [22]. Copolymers of type AB could be obtained by polymerization of a monofunctional homopolymer B followed by the addition of monomers of the homopolymer A which is crystallisable or by using monofunctional homopolymer B as a macroinitiator for the polymerization of the homopolymer A. On the other hand, copolymers of type (AB)_n are usually obtained by mixing monomers of both types having reactive compatible ending groups and represents a simpler technology. For industrial uses, copolymers of type (AB)_n are more attractive since the process is often simpler than for copolymers of type ABA or AB.

Since a biodegradable polyester was sought after, the preparation of pivalolactone monomers and their polymerization were investigated. Copolymers of pivalolactone are well known as thermoplastic elastomers but these copolymers are not energetic, moreover, it is not possible to introduce an energetic group on pivalolactone ring [23]. It is possible though to synthesize halogenated derivative of lactones having a structure similar to pivalolactones [24]. Since nucleophilic substitution of chlorine or bromine is possible by azide groups, these routes were chosen to prepare energetic lactone monomers and to synthesize energetic homopolymers. The poly halogenated pivalolactones have melting point between 100-250 °C [24] and it was thought that introducing azide groups would lower the melting point to the desired 80-85 °C as in BAMO. Indeed, the melting temperature of BAMO halogenated precursors was around 180-220 °C while the BAMO itself melted at 88°C [25-28].

To isolate energetic thermoplastic polyester, one can prepare the energetic monomer and polymerize it or polymerize the halogenated monomer and perform the azidation on the resulting polymer. In the present study, the novel energetic thermoplastic polyester was synthesized by polymerizing α -bromomethyl- α -methyl- β -propiolactone (BMMPL) or α -chloromethyl- α -methyl- β -propiolactone (CMMPL) to isolate poly (α -bromomethyl- α -methyl- β -propiolactone) (PBMMPL) or poly (α -chloromethyl- α -methyl- β -propiolactone) (PCMMPL). The azidation of PBMMPL or PCMMPL in dimethylformamide at 90°C and 120°C respectively yielded poly (α -azidomethyl- α -methyl- β -propiolactone) (PAMMPL). Many initiators are suitable for the polymerization of β -propiolactones. Cationic initiators usually lead to low molecular weight polymers while high molecular weight polymers can be obtained with the use of anionic or organometallic compounds [29-30]. Organometallic initiators are often used with small amounts of co-initiators, such as water, and polyhydroxylated compounds. Lithium t-butoxide was chosen to polymerize both lactones. Those skilled in the art will know that different functionalities of the polylactones can also be obtained using di, tri- or tetra functional initiators.

To prepare the energetic copolyether-ester thermoplastic elastomer, the dihydroxyl terminated prepolymer must be activated to serve as a macroinitiator. To remove the proton of the hydroxyl groups, many reagents can be used, such as organic and inorganic bases, and organometallic compounds. In this study, n-butyl lithium was chosen and used to generate the alkoxide ions with GAP [28]. The generated alkoxide ions initiated the polymerization of CMMPL or BMMPL. This copolymer was then reacted with sodium azide to isolate the energetic copolyether-ester thermoplastic elastomer which has the following structure:

PAMMPL-DHTEP-PAMMPL

where PAMMPL is the energetic polyester hard block A and DHTEP is the dihydroxyl terminated polyether GAP used as the soft block B. Our study concentrated on the use of GAP as the dihydroxyl terminated prepolymer but this copolymerization is not limited to and could be done with other hydroxyl terminated energetic prepolymers such as: poly 3-azidomethyl-3-methyloxetane (AMMO), poly 3-nitratomethyl-3-methyloxetane (NIMMO) and poly glycidyl nitrate (GLYN). Those

skilled in the art will see that the functionality of the soft segment is not restricted to two. In fact, using the process with a difunctional soft segment such as GAP resulted in an ABA triblock copolymer but using a monofunctional soft segment would have resulted in an AB diblock copolymer. The use of a tri-, tetra- or polyfunctional soft segment would have led to star shaped or grafted thermoplastic elastomers.

Different mechanical properties can be obtained by varying the molecular weights of the soft and hard segments. Soft to tough rubber or hard waxes are among the possibilities for the appearance of the copolymer. Commercially available glycidyl azide polymer has a molecular weight of 2000 g/mol and this prepolymer was used as the macroinitiator for the polymerization of BMMPL and CMMPL. To increase the elastomeric behavior of the copolymer, a higher molecular weight (50 000 g/mol) GAP was synthesized and used as the macroinitiator [29]. It was observed that more elasticity can be incorporated, but at the expense of a higher viscosity in the melted state.

As mentioned earlier, balancing the molecular weights of both segments can be challenging. It is believed that the best mechanical properties will be obtained when using a soft segment of 10 000 to 20 000 g/mol and hard segment of 6 000 to 10 000 g/mol on each side of the soft segment. Efforts to produce GAP at these molecular weights are still ongoing.

To increase the energy of the thermoplastic segment, one could imagine a polyester having a structure similar to BAMO so, poly-(α -diazidomethyl- β -propiolactone) (PDAMPL) was prepared. The syntheses of α -dibromomethyl- β -propiolactone (DBMPL) and α -dichloromethyl- β -propiolactone (DCMPL) and their polymerization and azidation were achieved using the same principles to yield a new energetic polyester homopolymer that can be used as a binder or be introduced in an energetic thermoplastic elastomer synthesis.

3. Experimental

GAP Mn=2000 g/mol (GAP 2000) was obtained from 3M company, Minnesota, U.S.A. GAP Mn=50 000 g/mol was synthesized according to a known process developed by Vandenberg for the synthesis of a high molecular weight polyepichlorohydrin (PECH) followed by the azidation of this PECH to yield a high molecular weight GAP which was used as a macroinitiator [29]. Most of the other chemicals were purchased from Aldrich Chem Co.

The monomers α -bromomethyl- α -methyl- β -propiolactone (BMMPL) and α -chloromethyl- α -methyl- β -propiolactone (CMMPL) have to be synthesized prior to their polymerization [31-33]. CMMPL could be synthesized in a one step synthesis while BMMPL requires three steps. According to Figure 1, 2,2-dibromomethyl propyl acetate (DBMPAc) is obtained by acetylation and bromation of 2-hydroxymethyl-2-methyl-1,3-propanediol (HMPD) in a one-pot step. DBMPAc is then oxidized to 2,2-dibromomethyl propionic acid (DBMPA) followed by lactonisation to isolate BMMPL. The same synthetic procedure was applied to prepare CMMPL, but started with the commercial 2,2-dichloromethyl propionic acid (DCMPA)(Fig. 2). Since only one step is needed to prepare CMMPL compared to three for the BMMPL, it would be more appropriate to use only CMMPL but once its polymerization is done with the macroinitiator, the azidation has to be conducted at 120°C. At this temperature, some degradation of GAP was observed as well as with the other energetic prepolymers. With PBMMPL, the temperature of azidation was 90 °C and degradation was not observed.

The syntheses of α -dibromomethyl- β -propiolactone (DBMPL) and α -dichloromethyl- β -propiolactone (DCMPL) were similar to the one of BMMPL, except that the starting material was pentaerythritol [34] (Fig.3). Three steps were needed to complete each synthesis. The first step involved, in both cases, the simultaneous halogenation and acetylation of pentaerythritol using hydrobromic or hydrochloric acid to give 3-bromo-2,2-dibromomethylpropyl acetate or 3-chloro-2,2-dichloromethylpropyl acetate, respectively. Those acetates were then oxidized to 3-bromo-2,2-dibromomethyl propionic acid or 3-chloro-2,2-dichloromethyl propionic acid. DBMPL or DCMPL were obtained by the cyclisation of the acids.

Polymerization of BMMPL and CMMPL yielded PBMMPL and PCMMPL that upon azidation gave the same PAMMPL. Copolymerization of BMMPL and CMMPL with GAP as the macroinitiator followed by azidation yielded an energetic copolyether-ester that melted at 80-85 °C. Polymerization of DBMPL and DCMPL was achieved to yield PDBMPL and PDCMPL. Azidation of both polymers gave the same PDAMPL.

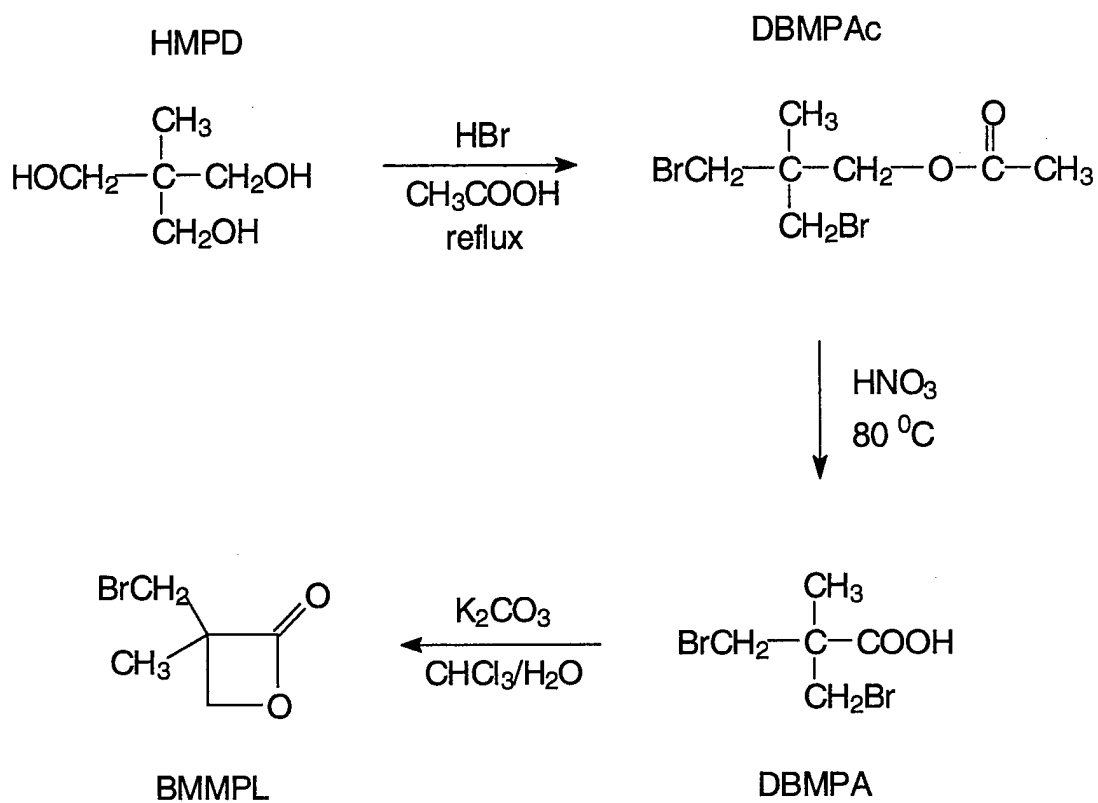

Figure 1: Synthesis of α -bromomethyl- α -methyl- β -propiolactone

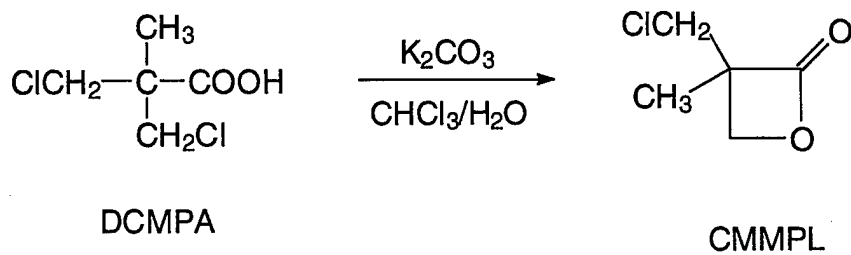

Figure 2: Synthesis of α -chloromethyl- α -methyl- β -propiolactone

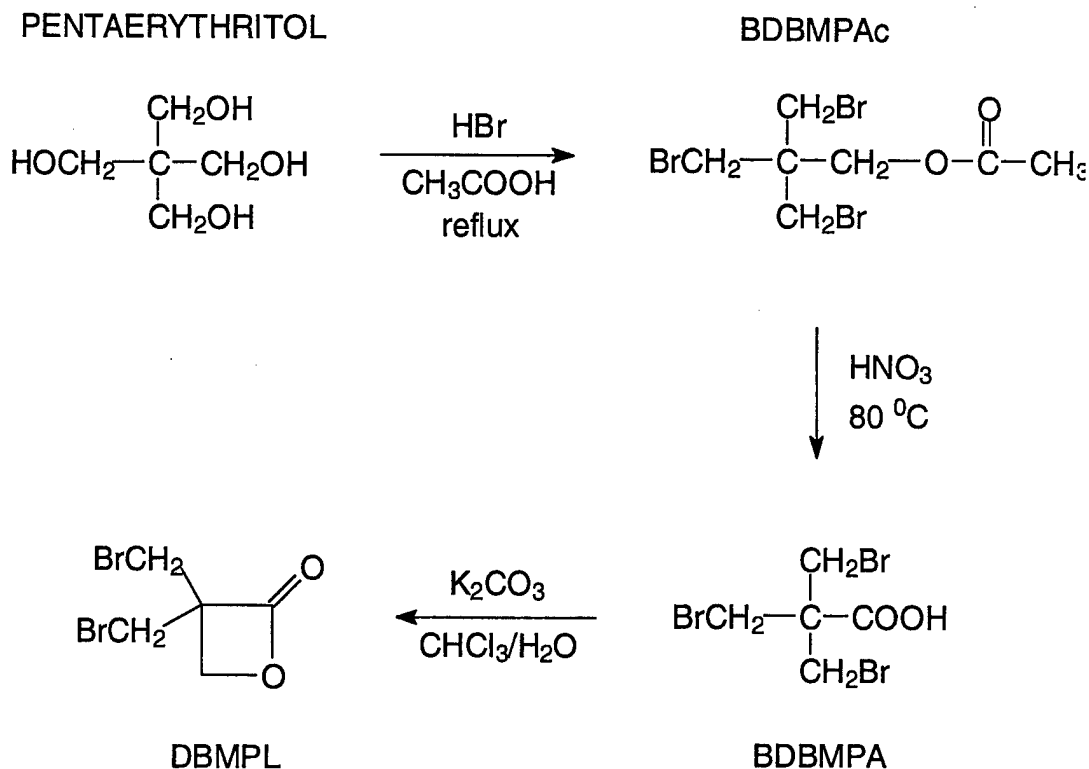

Figure 3: Synthesis of α -dibromomethyl- β -propiolactone

3.1 Preparation of α -bromomethyl- α -methyl- β -propiolactone (BMMPL)

3.1.1 Preparation of 2,2-dibromomethyl propyl acetate (DBMPAc)

In a round bottom flask, equipped with a condenser and a magnetic stirrer, a mixture of hydrogen bromide in acetic acid (30% w/w, 500 mL) and of 2-hydroxymethyl-2-methyl-1,3-propanediol (HMPD) (100 g, 0.833 mol) was heated to reflux for 24 hours. The solution was then cooled and transferred into a separatory funnel. After the addition of cold water (1.2 L), the organic phase was separated and distilled to yield 2,2-dibromomethyl propyl acetate. The fraction boiling at 80°C and 0.5 mm Hg was collected to yield 225 g of DBMPAc (0.781 mol, 94%).

^1H NMR: δ (CDCl_3) ppm: 1.18 (s, 3H, CH_3), 2.09 (s, 3H, CH_3CO), 3.42 (s, 4H, CH_2Br), 4.07 (s, 2H, CH_2).

^1H NMR = proton nuclear magnetic resonance, ^{13}C NMR = carbon nuclear magnetic resonance, J = coupling constant in hertz (Hz), s = singlet, d = doublet, q = quintuplet, m = multiplet

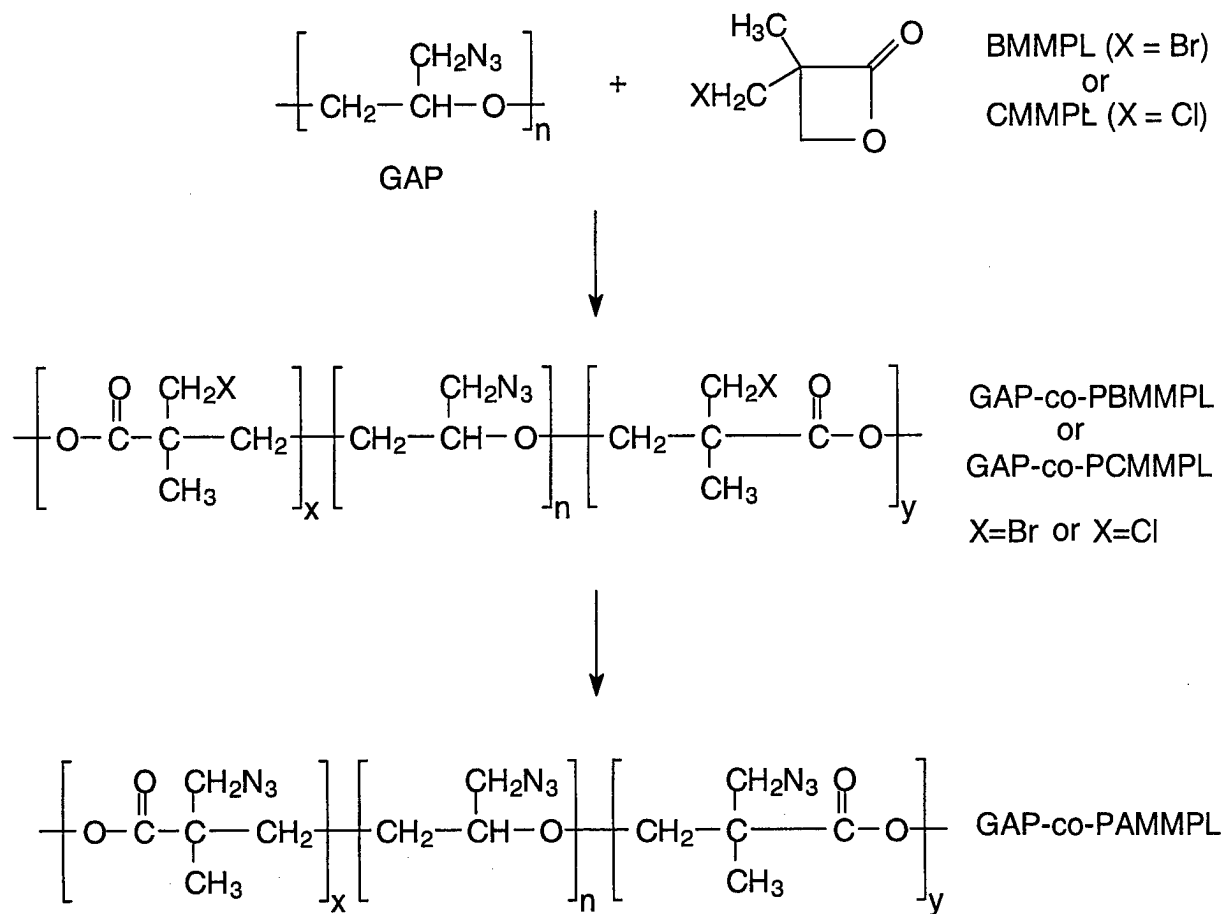

Figure 4: Copolymerization of GAP with propiolactones followed by azidation

3.1.2 Preparation of 2,2-dibromomethyl propionic acid (DBMPA)

In a three-neck flask equipped with an addition funnel, a large condenser, a thermometer and a magnetic stirrer, were introduced concentrated nitric acid (70%, 400 mL, 1.40 g/mL) and fuming nitric acid (50 mL, 1.52 g/mL). This solution was heated to 90 °C and DBMPAc (100 g, 0.347 mol) was added dropwise. The temperature was maintained at 80-90 °C for the duration of the addition. Red fumes evolved abundantly once approximately a third of the MDBMP was added. The mixture was heated at 80-90 °C for an additional two hours after the end of the addition and was stirred overnight at room temperature. It was then poured in 2 L of ice water. The solid was filtered, washed with ice water and used without further purification for the next step (73 g, 0.28 mol, 81%, Mp: 60-62 °C). The aqueous phase can be extracted with chloroform to yield a supplementary 16 g of DBMPA (0.062 mol) which need to be purified by recrystallization in a mixture benzene/petroleum ether to give almost a quantitative yield for the reaction.

¹HNMR: δ (CDCl₃) ppm: 1.49 (s, 3H, CH₃), 3.70 (q, 4H, CH₂Br), 10.5 (s, COOH).

3.1.3 Preparation of α -bromomethyl- α -methyl- β -propiolactone (BMMPL)

In a beaker equipped with a magnetic stirrer, DBMPA (60 g, 0.228 mol) was added to water (600 mL). To this suspension was added dropwise a potassium carbonate solution (1.0 M) until the pH of the solution was 8 (approximately 180 mL). When all the DBMPA was dissolved, the solution was quickly filtered into an erlenmeyer and methylene chloride was added (600 mL). This mixture was strongly stirred for 18 hours and poured into a separatory funnel. The organic phase was separated and the aqueous phase was washed with methylene chloride (2 x 300 mL). The organic phases were combined and dried over magnesium sulfate, filtered in a round bottom flask previously washed with hydrochloric acid (1 M) and evaporated to yield BMMPL (36 g, 0.20 mol). This product was rapidly filtered again on a neutral alumina column (5 x 10 mm) under dynamic vacuum into a round bottom flask also washed with HCl 1 M, dried over calcium hydride for three hours and distilled under vacuum over molecular sieves. The fraction boiling at 37-39 °C and 1 mm Hg was collected to yield 27 g (0.15 mol, 65%). This pure BMMPL can be stored over molecular sieves and under a nitrogen atmosphere at 5 °C.

¹HNMR: δ (CDCl₃) ppm: 1.59 (s, 3H, CH₃), 3.45, 3.67 (2 d, 2H, CH₂Br), 4.11, 4.39 (2 d, 2H, CH₂).

¹³CNMR: δ (CDCl₃) ppm: 19.08 (CH₃), 33.43 (CH₂Br), 58.99 (C), 71.33 (CH₂), 171.49 (CO).

3.2 Preparation of α -chloromethyl- α -methyl- β -propiolactone (CMMPL)

The synthesis of CMMPL is similar to the synthesis of BMMPL except that the starting available material was 2,2-dichloromethyl propionic acid (DCMPA) (20 g, 0.12 mol). It was poured in 800 mL of water, neutralized to pH 8 with a 1.0 M potassium carbonate solution (approximately 80-90 mL), filtered and vigorously agitated overnight with 800 mL of chloroform. The fraction boiling at 55-57 °C and 1 mm Hg was collected to yield 7.6 g (0.054 mol, 45%). This pure CMMPL can be stored over molecular sieve and under a nitrogen atmosphere at 5 °C.

¹HNMR: δ (CDCl₃) ppm: 1.56 (s, 3H, CH₃), 3.59, 3.81 (2 d, 2H, CH₂Cl), 4.12, 4.45 (2 d, 2H, CH₂).

¹³CNMR: δ (CDCl₃) ppm: 18.22 (CH₃), 45.30 (CH₂Cl), 59.48 (C) 70.11 (CH₂), 171.74 (CO).

3.3 Poly(α -bromomethyl- α -methyl- β -propiolactone) (PBMMPL)

Freshly distilled anhydrous BMMPL (2.21 g, 12.3 mmol) was injected into a flame-dried two-neck flask equipped with a magnetic stirrer, a nitrogen inlet and septa, previously flushed under vacuum and kept under a nitrogen stream. BMMPL was injected with a syringe precisely weighed before and after the injection. Anhydrous tetrahydrofuran (THF) (12.0 mL) was injected in the flask followed by an injection (496 μ L) of a solution of lithium t-butoxide in THF (1.0 mol/L). In less than five minutes, the mixture was solid. After 24 hours, this solid was stirred in methanol (80 mL), filtered and dried under vacuum at 60 °C for 24 hours. PBMMPL was isolated as a fine white powder (1.56 g, 71%) and was insoluble in most organic solvents. DSC analyses revealed a melting point of 230-245 °C followed by decomposition of the polymer and an enthalpy of fusion of between 40 Joules/g and 50 Joules/g. Since the polyester is insoluble, molecular weight could not be determined.

3.4 Poly(α -chloromethyl- α -methyl- β -propiolactone) (PCMMPL)

The procedure for the polymerization of CMMPL can be almost identical to the one for BMMPL, but other catalysts worked as well. As an example, a 1.0 M solution of triethylaluminium in hexane (2.24 mL, 2.24 mmol) and 20 μ L (1.11 mmol) of water were injected into a flame-dried two-neck flask equipped with a magnetic stirrer, a nitrogen inlet and septa, previously flushed under vacuum and kept under a nitrogen stream. The initiator was then reacted 0.5 h and dried under vacuum 0.5 h. Anhydrous toluene (9 mL) and freshly distilled CMMPL (2.9 g, 22 mmol) were added to the two-neck flask. The solution formed a gel very quickly. After two hours, the polymer was precipitated in a 10% v/v solution of hydrochloric acid in methanol (100 mL) and washed with pure methanol until neutral, filtered and dried under vacuum at 60 °C for 24 h. PCMMPL was isolated as a fine white powder (2.87 g, 99 %) and was insoluble in most organic solvents. DSC analyses revealed a melting point between 200 °C and 250 °C followed by decomposition of the polymer and an enthalpy of fusion of 60-75 J/g. Since the polyester is insoluble, its molecular weight could not be determined.

3.5 Poly(α -azidomethyl- α -methyl- β -propiolactone) (PAMMPL)

In a three-neck flask equipped with a condenser, a thermometer and a magnetic stirrer, were introduced PBMMPL (7.29 g, 40.7 mmol of CH₂Br) dimethylformamide (DMF, 88 mL) and sodium azide (2.92 g, 44.9 mmol). The suspension was heated to 90 °C for 18 hours and then poured in a beaker containing water (800 mL) to be

stirred vigorously. The polymer was isolated by filtration and dried under vacuum at 60 °C for 24 hours, yielding 6.66 g of PAMMPL (99%). According to NMR spectroscopy, the azidation was complete. DSC analyses revealed a melting point of 85 °C and an enthalpy of fusion of 35-40 J/g. Since the polyester is only partly soluble in common organic solvents, its molecular weight could not be determined.

¹HNMR: δ (DMSO) ppm: 1.1 (s, 3H, CH₃), 3.5 (s, 2H, CH₂N₃), 4.1 (s, 2H, CH₂).

¹³CNMR: δ (DMSO) ppm: 17.7 (CH₃), 46.8 (C), 54.1 (CH₂N₃), 66.3 (CH₂), 171.8 (CO).

The same procedure was applied with PCMMPL except that the temperature was 120 °C for 24 hours. PAMMPL was isolated as described with an overall yield of 71%. The spectroscopic analysis was identical. PAMMPL is a white cotton like solid that had a melting point of 80 °C and an enthalpy of fusion of 25-30 J/g. The molecular weight could not be determined because of the low solubility of this polymer in common organic solvents.

3.6 Synthesis of the copolymer GAP 2000-PAMMPL

3.6.1 Copolymerization of GAP 2000 with PBMMPL

GAP-2000 (0.316 g, 3.19 mmol of CH₂N₃) was thoroughly dried overnight under vacuum at 50 °C in a three-neck flask equipped with a stirrer, a nitrogen inlet and septa. GAP was then put under a nitrogen stream for the remainder of the reaction. Anhydrous tetrahydrofuran (3.2 mL) was added to the flask and, after complete dissolution of GAP, a 1.6 M solution of n-butyl lithium in hexane (0.164 mL, 0.263 mmol) was injected, followed by 1.012 g (5.65 mmol) of BMMPL. The material (1.10 g, 83%) was recuperated 24 h later by precipitation in methanol, filtration and drying overnight under vacuum at 60 °C. DSC analyses indicated a glass transition temperature of -29°C, characteristic of the soft segments of GAP. The melting point of the hard segments, expected above 200 °C from the results obtained for PBMMPL, could not be detected because of the decomposition of GAP beginning at 200 °C. The molecular weight of this material could not be determined because of its insolubility in common organic solvents. The copolymer was composed of 52% mol/mol GAP, as evaluated by the quantity of nitrogen in the polymer determined by elementary analysis (%C=34.5%, %H=4.5% %N=10.7%).

3.6.2 Azidation of the copolymer GAP 2000-PBMMPL

In a three-neck flask equipped with a condenser, a thermometer and a magnetic stirrer, were introduced (GAP 2000)-co-PBMMPL (0.204 g), dimethylformamide

(DMF, 4.0 mL) and sodium azide (0.074 g, 1.14 mmol). The suspension was heated to 90 °C for 18 hours and then poured in a beaker containing water to be stirred vigorously. After a few hours of agitation, the polymer stuck to the walls of the beaker; it was isolated by decantation of water and dried under vacuum at 60 °C for 24 hours, yielding 0.171 g of PAMMPL-GAP-PAMMPL. DSC analyses revealed a glass transition temperature of -26°C, a melting point between 80 °C and 85 °C and an enthalpy of fusion of 12 Joules/g. The molecular weight was estimated at 7300 g/mole from GPC measurements.

3.7 Synthesis of the copolymer GAP-PAMMPL with HMW GAP

3.7.1 Copolymerization of HMW GAP with PBMMPL

High molecular weight GAP (162.8 g, 1.64 mol of CH₂N₃) was thoroughly dried under vacuum at 50 °C for 4-5 days in a 4-L reaction kettle equipped with a mechanical stirrer, a nitrogen inlet and septa. GAP was then put under a nitrogen stream for the remainder of the reaction. Anhydrous tetrahydrofuran (3 L) was added to the reaction kettle and, after complete dissolution of GAP, a 1.6 M solution of n-butyl lithium in hexane (20.5 mL, 32.9 mmol) was injected, followed by 154.5 g (0.863 mol) of BMMPL. The material (270 g, 85%) was recuperated 24 h later by precipitation in methanol, filtration and drying under vacuum at 60 °C for 2-3 days. DSC analyses indicated a glass transition temperature of -32 °C, characteristic of the soft segments of GAP. The melting point of the hard segments, expected above 200 °C from the results obtained for PBMMPL, could not be detected because of the decomposition of GAP beginning at 200 °C. The molecular weight of this material could not be determined because of its low solubility in common organic solvents.

3.7.2 Azidation of the copolymer HMW GAP-PBMMPL

In a three-neck flask equipped with a condenser, a thermometer and a magnetic stirrer, were introduced PBMMPL-GAP-PBMMPL (250 g), dimethylformamide (DMF, 5.0 L) and sodium azide (91.0 g, 1.40 mol). The suspension was heated to 90 °C for 18 hours and then poured in a beaker containing water to be stirred vigorously. The polymer was isolated by filtration and dried under vacuum at 60 °C for 24 hours, yielding 160 g of PAMMPL-GAP-PAMMPL. DSC analyses revealed a glass transition temperature of -31 °C, a melting point of 86°C and an enthalpy of fusion of 2-3 Joules/g. Since the polyester is only partly soluble in common organic solvents, its molecular weight could not be determined.

3.8 Synthesis of α -dibromomethyl- β -propiolactone (DBMPL)

3.8.1 Preparation of 3-bromo-2,2-dibromomethylpropyl acetate (BDBMPAc)

This synthesis is similar to the one of DBMPAc, except that 60 g of pentaerythritol (0.45 mol) were reacted with 500 mL of hydrogen bromide in acetic acid (30% w/w). The yield of BDBMPAc after the extraction was 92% (152 g, 0.414 mol). This product can be used in the next step without additional purification.

$^1\text{HNMR}$: δ (CDCl_3) ppm: 2.11 (s, 3H, CH_3), 3.54 (s, 6H, CH_2Br), 4.19 (s, 2H, CH_2).

3.8.2 Preparation of 3-bromo-2,2-dibromomethyl propionic acid (BDBMPA)

This synthesis is similar to the one of DBMPA, except that for 100 g of BDBMPAc (0.272 mol), 310 mL of concentrated nitric acid (70%, 1.40 g/mL) and 36 mL of fuming nitric acid (1.52 g/mL) were needed. The total yield of BDBMPA (Mp: 83-86 °C) was 86% (72 g, 0.21 mol).

$^1\text{HNMR}$: δ (CDCl_3) ppm: 3.77 (s, CH_2Br).

3.8.3 Preparation of α -dibromomethyl- β -propiolactone (DBMPL)

This synthesis protocol was similar to that for BMMPL. Yields after distillation (55-59 °C, 1 mm Hg) were between 60% and 70%.

$^1\text{HNMR}$: δ (CDCl_3) ppm: 3.79 (s, 4H, CH_2Br), 4.45 (s, 2H, CH_2).

3.9 Synthesis of α -dichloromethyl- β -propiolactone (DCMPL)

3.9.1 Preparation of 3-chloro-2,2-dichloromethylpropyl acetate (CDCMPAc)

This synthesis protocol was similar that for BDBMPAc, except that 20 g of pentaerythritol (0.15 mol) were reacted at 160 °C in a closed vessel with 225 mL of hydrochloric acid and 75 mL of glacial acetic acid. After 24 h, the solution was cooled and transferred into a separatory funnel. After the addition of cold water (300 mL), the organic phase (14.1 g) was separated. NMR analysis revealed that this phase was constituted of a mixture of CDCMPAc (84%) and 2,2-dichloromethylpropyl acetate (DCMPAc). The rest of the solution was extracted with methylene chloride, dried and

evaporated to yield again a mixture (14.6 g) of CDCMPAc (46%) and DCMPAc. CDCMPAc could not be completely purified by distillation; it was noted that the boiling temperature raised continuously between 82 °C and 110°C (1 mm Hg). The first fraction (20.1 g), isolated between 82 °C and 102 °C, contained approximately 85% CDCMPAc, while the second one (4.2 g, 103-110 °C) was comprised of 73% CDCMPAc.

¹HNMR: δ (CDCl₃) ppm: 2.10 (s, 3H, CH₃), 3.64 (d, 6H, CH₂Cl), 4.16 (s, 2H, CH₂).

3.9.2 Preparation of 3-chloro-2,2-dichloromethyl propionic acid (CDCMPA)

The synthesis protocol was similar to that for DBMPA, except that for 24 g of CDCMPAc, 121 mL of concentrated nitric acid (70%, 1.40 g/mL) and 13.6 mL of fuming nitric acid (1.52 g/mL) were needed. The total yield of CDCMPA was 74% (15.9 g, 0.77 mol).

¹HNMR: δ (CDCl₃) ppm: 3.87 (s, CH₂Cl).

3.9.3 Preparation of α-dichloromethyl-β-propiolactone (DCMPL)

The synthesis protocol was similar to that for of BMMPL.

¹HNMR: δ (CDCl₃) ppm: 3.90 (d, 4H, CH₂Cl), 4.44 (s, 2H, CH₂).

3.10 Synthesis of Poly-α-dibromomethyl-β-propiolactone (PDBMPL)

The synthesis protocol was similar to that for PBMMPL and PCMMPL. PDBMPL was found to be a fine white powder that was insoluble in most common organic solvents.

3.11 Synthesis of poly(α-dichloromethyl-β-propiolactone) (PDCMPL)

The synthesis protocol was similar to that for PBMMPL and PCMMPL. PDBMPL was found to be a fine white powder that was insoluble in most common organic solvents.

3.12 Synthesis of poly(α -diazidomethyl- β -propiolactone) (PDAMPL)

The synthesis protocol was similar to that for PAMMPL, except that for 1.05 g of PDBMPL (4.07 mmol), 12.6 mL of dimethylformamide and 0.581 g of sodium azide (8.9 mmol) were needed. The molecular weight could not be determined because of the low solubility of PDAMPL in common organic solvents.

$^1\text{HNMR}$: δ (DMSO) ppm: 3.7 (s, 4H, CH_2N_3), 4.2 (s, 2H, CH_2).

4. Results and discussion

All the attempts to cause the azidation of BMMPL or CMMPL monomers failed and resulted in the polymerization of the lactones. Sodium azide as a nucleophile initiated the polymerization and poor yields with low molecular weights were observed. Therefore, the non-energetic lactones were synthesized and polymerized before their azidation to yield the energetic thermoplastic homopolymers. This was our preferred route since it minimized the number of manipulations with energetic materials. All the copolymerizations were done with GAP as the macroinitiator and different ETPEs were obtained.

4.1 Preparation of the Propiolactones

The monomers α -bromomethyl- α -methyl- β -propiolactone (BMMPL) and α -chloromethyl- α -methyl- β -propiolactone (CMMPL) were prepared according to a modified known procedure (Fig. 1 and 2) [24, 31-33]. CMMPL could be synthesized in one step since 2,2-dichloromethyl propionic acid is available commercially while BMMPL requires three steps starting from 2-hydroxymethyl-2-methyl-1,3-propanediol (HMPD). According to Figure 1, 2,2-dibromomethyl propyl acetate (DBMPAc) was obtained by acetylation and bromation of 2-hydroxymethyl-2-methyl-1,3-propanediol (HMPD) in a one-pot step. The procedure described by Litherland and Mann was modified and a solution of hydrobromic acid in acetic acid (HBr/AcOH 30% w/w) was used as the reagent [35]. After 24 hours of reaction, DBMPAc was isolated by distillation (80 °C, 0.5 mm Hg) with an excellent yield (94%). The NMR spectroscopy confirmed the structure and the introduction of the acetate. DBMPAc was then oxidized to 2,2-dibromomethyl propionic acid (DBMPA) in an almost quantitative yield. The first crop of solid was pure enough to be used directly for the next step and yielded DBMPA (m.p. 60-62 °C). Extraction of the aqueous phase with chloroform yielded more DBMPA than once recrystallized in a mixture of benzene/petroleum ether made the reaction almost quantitative. The NMR spectroscopy confirmed that the acetate group was removed and the methylene group was oxidized to carboxylic acid since the signals at 2.09 and 4.07 ppm corresponding respectively to the acetate and to the methylene disappeared. A signal corresponding to the proton of the carboxylic acid was observed at 10.5 ppm. The cyclisation of DBMPA was done using a potassium carbonate solution. The neutralization of the acidic proton followed by the nucleophilic substitution of the bromine atom resulted in the formation of the lactone. BMMPL was isolated from the distillation (37-39 °C, 1 mm Hg) with a good yield (65%). The spectroscopy confirmed the structure of a lactone with signals corresponding to the methyl at 1.59 ppm, to methylene and bromomethyl groups as AB systems at 4.11-4.39 and 3.45-3.67 ppm respectively. The overall yield for these three steps synthesis of BMMPL is around 60% if we consider the second step as almost quantitative.

The same synthetic procedure was applied to prepare CMMPL, but started with the commercial 2,2-dichloromethyl propionic acid (DCMPA) (Fig. 2). The removal of the acidic proton by the carbonate group followed by the nucleophilic substitution of the chlorine atom resulted in the formation of the lactone. CMMPL was isolated from the distillation (55-57 °C, 1 mm Hg) with a good yield (45%). The spectroscopy confirmed the structure of a lactone with signals corresponding to the methyl at 1.56, to methylene and chloromethyl groups as AB systems at 4.12-4.45 and 3.59-3.81 respectively. The overall yield for the synthesis of CMMPL is 45% which is lower than for BMMPL.

Since only one step with a yield of 45% is needed to prepare CMMPL compared to three with an overall yield at 60% for the BMMPL and considering the fact that more manipulations are needed to prepare BMMPL, it would be more appropriate to use only CMMPL. However, the azidation of PCMMPL has to be conducted at 120°C which induces some degradation of the polymer. With PBMMPL, the temperature of azidation was 90 °C and degradation was not observed. It was decided to choose this route for the preparation of the polylactones.

The syntheses of α -dibromomethyl- β -propiolactone (DBMPL) and α -dichloromethyl- β -propiolactone (DCMPL) were similar to the one of BMMPL, except that the starting material was pentaerythritol (Fig.3) [34]. Three steps were needed to complete each synthesis. The first step involved, in both cases, the simultaneous halogenation and acetylation of pentaerythritol to give 3-bromo-2,2-dibromomethylpropyl acetate or 3-chloro-2,2-dichloromethylpropyl acetate, respectively. The modified Litherland procedure was used to prepare BDBMPAc and CDCMPAc with a solution of hydrobromic acid in acetic acid (HBr/AcOH 30% w/w). The advantage of the modified procedure was that the lower water concentration in the reaction medium allowed to perform the reaction directly on pentaerythritol instead of preparing the tetraacetyl derivative as explained in the literature [35]. BDBMPAc was easier to prepare and better results and yields were obtained compared with CDCMPAc. Conditions to prepare BDBMPAc were identical to the ones used to prepare DBMPAc and the product was isolated pure enough to be used in the next step without additional purification with a yield of 92%. The NMR spectroscopy of this product was in accordance with the structure of BDBMPAc with signals at 2.11, 3.54 and 4.19 for the methyl, to bromomethyl and methylene groups respectively. CDCMPAc was prepared using slightly different conditions: Pentaerythritol, hydrochloric acid and acetic acid were heated in a closed vessel at 160 °C to give a mixture of CDCMPAc and DCMPAc with a yield of 43% in CDCMPAc. The purification by distillation was difficult and CDCMPAc could not be completely purified. The boiling temperature was continuously rising between 82-110 °C at 1 mm Hg and the fraction collected between 82 and 102 °C contained CDCMPAc at 85%. The second fraction contained 73% of CDCMPAc. The NMR spectroscopy was identical to BDBMPAc excepted that the signals were observed at 2.10, 3.64 and 4.16 ppm.

The next step was the oxidation of the two acetates to give 3-bromo-2,2-dibromomethyl propionic acid or 3-chloro-2,2-dichloromethyl propionic acid using the same procedure than DBMPA. BDBMPA was isolated with a yield of 86% (m.p.

83-86 °C). The NMR spectra showed only one signal corresponding to bromomethyl groups at 3.77 ppm. In the same conditions, the yield for CDCMPA was 74% and the NMR signal corresponding to chloromethyl groups was observed at 3.87 ppm. DBMPL or DCMPL were obtained by the cyclisation of these acids according to the same procedure used to produce BMMPL. The yields for both dihalogenated lactones were 60-70% and their spectroscopy showed small differences such as a doublet observed for the chloromethyl groups while a singlet was observed for the bromomethyl groups. Two signals were observed for the halomethyl groups and the methylene groups at 3.79 and 4.45 for DBMPL and at 3.90 and 4.44 for DCMPL.

4.2 Polymerization of Propiolactones

Freshly distilled BMMPL was charged into a flask and polymerized using lithium t-butoxide. It is known that alkoxide or carboxylate ions initiate the opening and polymerization of lactones [23-24]. Since we had in mind to use GAP as the macroinitiator, we concentrated our efforts in studying the polymerization of the lactones with alkoxide ions. Carboxylate ions can attack only at the β position giving a regular structure having carboxylate ending groups. The alkoxide ions can attack both the carbonyl and the β position. The use of alkoxide ions could therefore lead to defects and different ending groups in the polyester lowering its melting point. Nevertheless, alkoxide ions were chosen because of their simplicity of use and also because our main target was not to build a perfect structure, but instead to obtain a thermoplastic segment with a melting point of 85 °C. PBMMPL was isolated as a fine white powder (71%). DSC analysis revealed a melting point at 230-245 °C. Since most of the polyester synthesized in this study were insoluble in common organic solvents, their molecular weights could not be determined.

CMMPL was also polymerized. The same initiator than for the polymerization of BMMPL could be used but other worked as well. Triethylaluminum in hexane was used to polymerize CMMPL and PCMMPL was isolated at 99% yield. Its melting point was around 200-250 °C as measured by DSC analysis. This polymer was also insoluble.

PBMMPL and PCMMPL were reacted with sodium azide in DMF to yield respectively PAMMPL at 99 and 71% yields. According to NMR spectroscopy, the azidation was complete. The differences between the azidation of PBMMPL and PCMMPL was the temperature and the duration of the reaction. PBMMPL was azidated at 90 °C for 18 hours while PCMMPL required 24 hours at 120°C. Both polymers had identical spectroscopies. DSC analyses revealed a melting point at 85 °C for the PAMMPL coming from PBMMPL and a melting point of 80 °C for the PAMMPL coming from PCMMPL. The molecular weight of both PAMMPL samples could not be determined because of their low solubility in common organic solvents.

Polymerization of DBMPL and DCMPL were achieved using the same procedure used for the preparation of PBMMPL (lithium t-butoxide). Since the DBMPL was an unstable monomer, very difficult to purify, its polymerization was difficult and yields

as low as 40% were observed. The same observations were made with DCMPL. The crystallinity of PDBMPL and PDCMPL was also very low and melting points between 59-150 °C were observed in some cases. The NMR spectroscopy was difficult to achieve since the samples were almost insoluble. Azidation of these samples was achieved in DMF using sodium azide. The solubility of the samples was high enough for the NMR analysis but not for a molecular weight determination. Preliminary DSC analysis revealed that the PDAMPL could be amorphous. Therefore, no copolymerization with GAP as the macroinitiator was achieved yet. Work is still in progress in this area.

4.3 Copolymerization of Propiolactones with GAP

As mentioned before, the azidation of PCMMPL was at 120 °C induced some degradation of the polymer chains. Azidation at lower temperatures led to incomplete substitution. Since these problems were not encountered with the bromo derivative PBMMPL, it was decided to concentrate our efforts on the copolymerization of the PBMMPL with GAP. Commercially available GAP of molecular weight 2000 was reacted with n-butyl lithium to produce a macroinitiator that was used to initiate the polymerization of BMMPL (Fig. 4). The resulting copolymer was recuperated by precipitation in methanol (83% yield). DSC revealed a glass transition of -29 °C related to the soft segment GAP. The melting point of the hard segment, expected to be over 200 °C from the results obtained with PBMMPL, could not be detected because of the decomposition of GAP beginning at 200 °C. CHN analysis revealed that the copolymer was composed of 52% mol/mol GAP. Again, this copolyether-ester was not soluble enough to allow the molecular weight determination. The azidation of the copolymer was done in the same conditions than for the azidation of the PBMMPL (90 °C, 18 hours). The resulting PAMMPL-GAP-PAMMPL was isolated at 84% yield. DSC analysis revealed a glass transition of -26 °C and a melting point of 80-85 °C. The molecular weight was estimated at 7300 g/mole from GPC measurements. The product was a hard wax not elastic enough to be introduced and used as an energetic thermoplastic elastomer into an explosive formulation. Attempts were made to lower the molecular weight of the hard segments but failed to produce the best candidate for insensitive formulation. It was thought that GAP 2000 does not have a molecular weight high enough to produce the desired elastomeric behaviour. More elasticity is still needed and work is still ongoing to produce the ideal ETPE. It was decided to produce a high molecular weight GAP to increase the elasticity of the resulting copolymer.

High molecular weight GAP (50000-70000 g/mole) was prepared using the Vandenberg approach [29]. This prepolymer was reacted with n-butyl lithium and used as the macroinitiator to initiate the polymerization of BMMPL. The resulting copolymer was isolated 24 hours later from precipitation in methanol followed by filtration and drying under vacuum at 60 °C for 2-3 days (85% yield). DSC analysis revealed a glass transition temperature of -32 °C related to the soft segment GAP. The melting point could not be observed for reasons already mentioned for the GAP 2000-PBMMPL copolymer. Azidation of the resulting copolymer yielded the

energetic copolyether-ester thermoplastic elastomer with a yield of 70%. DSC analysis revealed a glass transition temperature of $-31\text{ }^{\circ}\text{C}$ and a melting point of $86\text{ }^{\circ}\text{C}$. This copolymer had excellent rubbery characteristics but did not flow above its fusion temperature since it was too viscous. The molecular weight could not be determined because of its low solubility. More work is still ongoing to prepare a GAP sample having a molecular weight of $15,000\text{ g/mole}$. It is still believed that the ETPE that will melt and flow above the melting point and be a good rubber will have a soft segment around $10,000\text{-}20,000\text{ g/mole}$ with hard segments on each side having molecular weight of $6,000\text{-}10,000\text{ g/mole}$. As already mentioned, balancing the hard and the soft segment could be very challenging.

5. Conclusion

It was shown that new energetic thermoplastic homopolymers melting at 80-85 °C can be synthesized. A route to produce poly- α -azidomethyl- α -methyl- β -propiolactone which consisted in polymerizing halogenated propiolactones and substituting the halogen by an azide groups was developed. This new energetic thermoplastic polyester homopolymer melted at 80-85 °C. To produce this polymer, the halogenated propiolactones monomers α -bromomethyl- α -methyl- β -propiolactone and α -chloromethyl- α -methyl- β -propiolactone were prepared to synthesize poly- α -bromomethyl- α -methyl- β -propiolactone and poly- α -chloromethyl- α -methyl- β -propiolactone that upon azidation gave poly- α -azidomethyl- α -methyl- β -propiolactone. It was found that α -chloromethyl- α -methyl- β -propiolactone could be synthesized in a one step synthesis while α -bromomethyl- α -methyl- β -propiolactone required three steps. In this context, 2,2-dibromomethyl propyl acetate was obtained by acetylation and bromation of 2-hydroxymethyl-2-methyl-1,3-propanediol in a one-pot step. 2,2-dibromomethyl propyl acetate was oxidized to 2,2-dibromomethyl propionic acid that upon cyclisation gave the α -bromomethyl- α -methyl- β -propiolactone. To prepare the chloro derivative of the lactone, the synthesis was done in one step starting with the commercial 2,2-dichloromethyl propionic acid. Polymerization of both lactones can be accomplished by the use of lithium t-butoxide as the initiator. It was also found that the azidation of poly- α -chloromethyl- α -methyl- β -propiolactone has to be conducted at 120°C. Some degradation of the polymer chains was however observed at this temperature. With poly-(α -bromomethyl- α -methyl- β -propiolactone), the temperature of azidation was 90 °C and degradation was not observed. The overall yield, the number of steps and the degradation of poly-(α -chloromethyl- α -methyl- β -propiolactone) on azidation prompted us to produce and concentrate our efforts on α -bromomethyl- α -methyl- β -propiolactone.

By analogy to the BAMO structure, the syntheses of α -dibromomethyl- β -propiolactone and α -dichloromethyl- β -propiolactone were also achieved. Their polymerization and azidation were done according to procedures similar to the ones used to prepare the other lactones except that the starting material was pentaerythritol. Preliminary analysis revealed that the energetic homopolymer could be amorphous.

Copolymerizations using commercial GAP 2000 and synthetic high molecular weight GAP as macroinitiators for the α -bromomethyl- α -methyl- β -propiolactone polymerization were achieved. In the former case, GAP 2000 was not able to give enough elasticity to the energetic thermoplastic elastomer. Even by lowering the molecular weight of the hard segment, still hard waxes were obtained with GAP 2000 as the soft block. Using high molecular weight GAP solved the elasticity problem and excellent rubbery material was obtained but at the expense of a very high viscosity above the melting point temperature. In fact, the material did not flow at temperatures higher than the melting point. Work is still ongoing to prepare a GAP sample having a molecular weight of 10,000-20,000 g/mole to increase the elastomeric character of the ETPE and to polymerize hard segments of 6,000-10,000 g/mole on each end.

6. References

1. Frankel, M.B., Grant, L.R. and Flanagan, J.E., "Historical Development of Glycidyl Azide Polymer"; *Journal of Propulsion and Power*, 8 (3), 560, 1992.
2. Leach, C., Debenham, D., Kelly, J. And Gillespie, K., "Advances in PolyNIMMO Composite Gun propellants", *Propellants, Explosives, Pyrotechnics*, 23, 313, 1998.
3. Lessard, P., Druet, L., Villeneuve, S., Thiboutot, S., Benchabane, M. and Alexander, D., "Development of a Minimum Smoke Propellant Based on Glycidyl Azide Polymer and Ammonium Nitrate", NATO Advisory Group for Aerospace Research and Development, Conference Proceedings AGARD-CP-511 on Insensitive Munitions, Bonn (Germany), 1991.
4. Hooton, I., Bélanger, C. and Pelletier, P., "Preliminary Studies of Energetic Binder Based PBXs", (U) DREV M-2996/89, August 1989, CONFIDENTIAL.
5. Hooton, I. and Bélanger, C., "Improvements in GAP-Based Plastic Bonded Explosive Formulations" (U); DREV M-3154/93, October 1993, CONFIDENTIAL.
6. Villeneuve, S. and Carignan, P., "Binders for Rocket Propellant Formulations Based on Glycidyl Azide Polymers", DREV R-4631/91, February 1991, UNCLASSIFIED.
7. Henke, K., Böhnlein-Maub, J. and Schubert, H., "Characteristic Properties of AN/GAP-Propellants"; *Propellants, Explos., Pyrotech.*, 21, 139, 1996.
8. Oyumi, Y., Kimura, E., Hayakama, S., Nakshita, G. and Kato, K., "Insensitive Munitions(IM) and Combustion Characteristics of GAP/AN Composite Propellants"; *Propellants, Explos., Pyrotech.*, 21, 271, 1996.
9. Oyumi, Y. and Nagayama, K., "Development of High Burn Rate Azide Polymer Propellant"; *J. Energetic Materials*, 15, 59, 1997.
10. Hori, K. and Kimura, M., "Combustion Mechanism of Glycidyl Azide Polymer"; *Propellants, Explos., Pyrotech.*, 21, 160, 1996.
11. Kubota, N., Yano, Y., Miyata, K., Kuwahara, T., Mitsuno, M. and Nakagawa, I., "Energetic Solid Fuels for Ducted Rockets(II)"; *Propellants, Explos., Pyrotech.*, 16, 287, 1991.
12. Ampleman, G., Lee, A.K. and Lavigne, J., "The Curing of Glycidyl Azide Polymer with Diisocyanates", DREV M-3023/90, May 1990, UNCLASSIFIED.

13. Ampleman, G., Désilets, S. and Marois, A., "A New Class of Glycidyl Azide Polymers with Increased Functionality and Reactivity: Part I – Synthesis"; DREV R-4680/92, December 1992, UNCLASSIFIED.
14. Villeneuve, S. and Ampleman, G., "Curing and Tensile Mechanical Properties of Binders Based on Increased Functionality Glycidyl Azide Polymer"; DREV M-3142/93, May 1993, UNCLASSIFIED.
15. Désilets, S., Ampleman, G. and Marois, A., "A New Class of Glycidyl Azide Polymer with Increased Functionality and Reactivity: Part II – Characterization" (U); DREV R-4715/94, April 1994, CONFIDENTIAL.
16. Hepburn, C., "Polyurethane Elastomers", Applied Science Publishers, London, 1982.
17. Stacer, R. and Husband, D.M., "Molecular Structure of the Ideal Solid Propellant Binder"; Propellants, Explos., Pyrotech., 16, 167, 1991.
18. Manser, G., "Nitramines Oxetanes and Polyethers Formed Therefrom"; U.S. Patent 4,707,540, 1987.
19. Wardle, B., "Method of Producing Thermoplastic Elastomers Having Alternate Crystalline Structure for Use as Binders in High-Energy Composition"; U.S. Patent 4,806,613, 1989.
20. Wardle, B., "Synthesis of ABA Triblock Polymers and AnB Star Polymers From Cyclic Ethers"; U.S. Patent 4,952,644.
21. West, J.C. and Cooper, S.L., "Thermoplastic Elastomers", Science and Technology of Rubbers, Academic Press, Chapter 13, pp. 531-567, 1978.
22. Manser, G.E. and Fletcher, R.W., "Energetic Thermoplastic Elastomers", Summary Report, Office of Naval Research Contract N00014-87-C-0098, 1988.
23. Tijsma, E.J., Van der Does, L., Bantjes, A., et Vuliel, J., "Synthesis, Structure and Properties of Polymers Based on Pivalolactone"; J.M.S.-Rev. Macromol. Chem. Phys. C-34, 515, 1994.
24. Johns, D.B. and Lenz, R.W., "Ring Opening Polymerization"; T.J. Ivin and T. Saegusa eds, Elsevier, NY, Vol 1, Chap 7, 1984.
25. Wunderlich, B., "Macromolecular physics"; Academic Press, NY, Vol 1, Tab IV.1, 1973, and Vol 3, Tab VIII.6, 1980.
26. Campbell, T.W., "Some Reactions of 3,3-Bis(Chloromethyl) Oxetane"; J. Org. Chem., 22,1029, 1957.
27. Hardenstine, K.E., Henderson Jr, G.V.S., Sperling, L.H., Murphy, C.J., and Manser, G.E., "Crystallization Behavior of Poly (3,3-Bisethoxymethyl Oxetane)

- and Poly (3,3-Bisazidomethyl Oxetane)"; J. Polym. Sci., Polym. Phys. Ed., 23, 1597, 1985.
28. Yamashita, Y and Hane, T., "Block Polymerization VI. Polymerization of Pivalolactone With Macromolecular Initiators From Polystyrene and Polytetrahydrofuran"; J. Polym., Polym. Chem. Ed., 11, 425, 1973.
 29. Vandenberg, E. J., "Macromolecular Chemistry"; John Wiley and Sons: New-York, 1972; Vol.4, p.49.
 30. Kim, C. S., Kuo, L., Fish, R., Russell, J., Curb, P. and Immoos, J., "Telechelic Polymerization of Epichlorohydrin Using 1,4-Butanediyl Ditriflate as The initiator"; Macromolecules, 23, 4715, 1990.
 31. Vickers, E.J. and Reynolds, R.J.W., "A New Lactone and Polyesters Therefrom"; Imperial Chemical Industries Limited, GB patent 775,495, 1957.
 32. Reynolds, R.J.W. and Vickers, E.J., " α : α -Bis-(Chloromethyl)- β -Propiolactone and Process For Its Production"; Imperial Chemical Industries Limited, US patent 2,977,373, 1961.
 33. Reynolds, R.J.W. and Vickers, E.J., "New Lactones"; Imperial Chemical Industries Limited, US patent 2,853,474, 1958.
 34. Thiebaut, R., Fischer, N., Etienne, Y. et Coste, J., "Nouveaux polyesters à partir de bêta-lactones substitués"; Industrie des Plastiques Modernes, 13, 1962.
 35. Litherland, A. and Mann, F.G., "The Amino Derivatives of Pentaerythritol. Part I. Preparation"; J. Chem. Soc., 1588, 1938.

List of symbols/abbreviations/acronyms/initialisms

¹³ C NMR	Carbon-13 Nuclear Magnetic Resonance Spectroscopy
¹ H NMR	Proton Nuclear Magnetic Resonance Spectroscopy
AMMO	Poly-3-azidomethyl-3-methyl-oxetane
BAMO	Poly-bis-azidomethyl-3-methyl-oxetane
CRDV	Centre de recherches pour la défense Valcartier
DHTEP	Dihydroxyl Terminated Prepolymer
DMF	N,N-Dimethyl Formamide
DND	Department of National Defence
DREV	Defence Research Establishment Valcartier
DSC	Differential Scanning Calorimetry
ETPE	Energetic Thermoplastic Elastomer
GAP	Glycidyl Azide Polymer
GLYN	Poly-Glycidyl Nitrate
HBr	Hydrobromic Acid
HCl	Hydrochloric Acid
NIMMO	Poly-3-nitratomethyl-3-methyl-oxetane
PAG	Polyazoture de glycidyle
PBX	Plastic Bounded Explosive
PECH	Polyepichlorohydrin
RDX	Research Development Explosive

THF	Tetrahydrofuran
TPE	Thermoplastique élastomère
TPEE	Thermoplastique élastomère énergétique

Glossary

AMMPL	α -Azidomethyl- α -methyl- β -propiolactone
BDBMPA	3-Bromo-2,2-dibromomethyl propionic acid
BDBMPAc	3-Bromo-2,2-dibromomethyl propyl acetate
BMMPL	α -Bromomethyl- α -methyl- β -propiolactone
CDCMPA	3-Chloro-2,2-dichloromethyl propionic acid
CDCMPAc	3-Chloro-2,2-dichloromethyl propyl acetate
CMMPL	α -Chloromethyl- α -methyl- β -propiolactone
DBMPA	2,2-Dibromomethyl propionic acid
DBMPAc	2,2-Dibromomethyl propyl acetate
DBMPL	α -Dibromomethyl- β -propiolactone
DCMPA	2,2-Dichloromethyl propionic acid
DCMPL	α -Dichloromethyl- β -propiolactone
HMPD	2-Hydroxymethyl-2-methyl-1,3-propanediol
HMWGAP	High Molecular Weight Glycidyl Azide Polymer
PAMMPL	Poly- α -azidomethyl- α -methyl- β -propiolactone
PBMMPL	Poly- α -bromomethyl- α -methyl- β -propiolactone
PCMMPL	Poly- α -chloromethyl- α -methyl- β -propiolactone
PDAMPL	Poly- α -diazidomethyl- β -propiolactone
PDBMPL	Poly- α -dibromomethyl- β -propiolactone
PDCMPL	Poly- α -dichloromethyl- β -propiolactone

Distribution list (Internal)

- 1 - Director General
- 1 - H/EM Section
- 6 - Document Library
- 1 - Dr. G. Ampleman (author)
- 1 - Dr. S. Brochu (author)
- 1 - Ms. M. Desjardins (author)
- 1 - Dr. S. Thiboutot
- 1 - Dr. L.-S. Lussier
- 1 - Dr. S. Désilets
- 1 - Mr. P. Brousseau
- 1 - Dr. C. Dubois
- 1 - Mr. P. Dubé
- 1 - Dr. F. Wong
- 1 - Mr. P. Lessard
- 1 - Ms. S. Villeneuve
- 1 - Ms. E. Diaz

Distribution list (External)

- 1 - DRDKIM
- 1 - DRDKIM (unbound copy)
- 1 - DRDC
- 1 - DSTL
- 1 - DSTL-3
- 1 - DSAA
- 1 - DSAM
- 3 - DAPM-3
- 1 - DMCS
- 1 - DARFT
- 1 -3M Corporation
 - Milwaukee, Minnesota
 - attention: Mr. T. Manzara
- 1- Bibliothèque Nationale du Canada
- 1- ICIST
- 1- BNC
- 1- DTIC

SANS CLASSIFICATION
COTE DE SÉCURITÉ DE LA FORMULE
(plus haut niveau du titre, du résumé ou des mots-clefs)

FICHE DE CONTRÔLE DU DOCUMENT

1. PROVENANCE (le nom et l'adresse)
CRDV

2. COTE DE SÉCURITÉ
(y compris les notices d'avertissement, s'il y a lieu)
non classifié

3. TITRE (Indiquer la cote de sécurité au moyen de l'abréviation (S, C, R ou U) mise entre parenthèses, immédiatement après le titre.)
Synthesis of Energetic Polyester Thermoplastic Homopolymers and Energetic Thermoplastic Elastomer Formed Therefrom

4. AUTEURS (Nom de famille, prénom et initiales. Indiquer les grades militaires, ex.: Bleau, Maj. Louis E.)
G. Ampleman, S. Brochu et M. Desjardins

5. DATE DE PUBLICATION DU DOCUMENT (mois et année)
Oct 2001

6a. NOMBRE DE PAGES
42

6b. NOMBRE DE REFERENCES
35

7. DESCRIPTION DU DOCUMENT (La catégorie du document, par exemple rapport, note technique ou memorandum. Indiquer les dates lorsque le rapport couvre une période définie.)
rapport du CRDV

8. PARRAIN (le nom et l'adresse)

9a. NUMÉRO DU PROJET OU DE LA SUBVENTION
(Spécifier si c'est un projet ou une subvention)

9b. NUMÉRO DE CONTRAT

10a. NUMÉRO DU DOCUMENT DE L'ORGANISME EXPÉDITEUR

10b. AUTRES NUMÉROS DU DOCUMENT

N/A

11. ACCÈS AU DOCUMENT (Toutes les restrictions concernant une diffusion plus ample du document, autres que celles inhérentes à la cote de sécurité.)

- Diffusion illimitée
- Diffusion limitée aux entrepreneurs des pays suivants (spécifier)
- Diffusion limitée aux entrepreneurs canadiens (avec une justification)
- Diffusion limitée aux organismes gouvernementaux (avec une justification)
- Diffusion limitée aux ministères de la Défense
- Autres

12. ANNONCE DU DOCUMENT (Toutes les restrictions à l'annonce bibliographique de ce document. Cela correspond, en principe, aux données d'accès au document (11). Lorsqu'une diffusion supplémentaire (à d'autres organismes que ceux précisés à la case 11) est possible, on pourra élargir le cercle de diffusion de l'annonce.)

SANS CLASSIFICATION
COTE DE LA SÉCURITÉ DE LA FORMULE
(plus haut niveau du titre, du résumé ou des mots-clefs)

SANS CLASSIFICATION

COTE DE LA SÉCURITÉ DE LA FORMULE
(plus haut niveau du titre, du résumé ou des mots-cléfs)

13. SOMMAIRE (Un résumé clair et concis du document. Les renseignements peuvent aussi figurer ailleurs dans le document. Il est souhaitable que le sommaire des documents classifiés soit non classifié. Il faut inscrire au commencement de chaque paragraphe du sommaire la cote de sécurité applicable aux renseignements qui s'y trouvent, à moins que le document lui-même soit non classifié. Se servir des lettres suivantes: (S), (C), (R) ou (U). Il n'est pas nécessaire de fournir ici des sommaires dans les deux langues officielles à moins que le document soit bilingue.)

(u) For many years, DREV has been involved in the synthesis of energetic thermoplastic elastomers (ETPEs) based on linear glycidyl azide polymer (GAP). These polymers are physically-crosslinked rubbery materials that can be melted or dissolved, recycled and could provide a new generation of binders. Since ETPEs are recyclable, disposal of the formulations at the end of their life cycle will be less problematic. Work at DREV led to the preparation of a new thermoplastic segment. The polymerization of α -bromomethyl- α -methyl- α -propiolactone (BMMPL) or α -chloromethyl- α -methyl- α -propiolactone (CMMPL) yielded thermoplastic homopolymers that upon azidation led to a novel energetic thermoplastic polyester: poly (α -azidomethyl- α -methyl- α -propiolactone) (PAMMPL). An energetic copolyether-ester thermoplastic elastomer was prepared by using glycidyl azide polymer as a macroinitiator for the polymerization of BMMPL or CMMPL. The azidation of the resulting copolyether-ester yielded an energetic thermoplastic elastomer that melted at 80-85° C. Polymerization of the α -dibromomethyl- α -propiolactone (DBMPL) resulted in a polymer which upon azidation yielded a new energetic polymer that can be used as a binder or into an energetic thermoplastic elastomer synthesis. This paper describes mainly the synthesis and the characterization of these new ETPEs.

(nc) Pendant plusieurs années, le CRDV a été impliqué dans la synthèse de thermoplastiques élastomères énergétiques (TPEE) basés sur le polyazoture de glycidyle linéaire. Ces polymères sont des caoutchoucs réticulés physiquement qui peuvent être fondus ou dissous, recyclés et peuvent représenter une nouvelle génération de liants. Comme les TPEEs sont recyclables, l'élimination de ces formulations à la fin de leur cycle de vie sera moins problématique. Le travail au CRDV a conduit à la préparation d'un nouveau segment thermoplastique. La polymérisation de l' α -bromométhyl- α -méthyl- α -propiolactone (BMMPL) ou de l' α -chlorométhyl- α -méthyl- α -propiolactone (CMMPL) a donné des homopolymères thermoplastiques qui, une fois azoturés, a conduit à un nouveau polyester thermoplastique énergétique: le poly (α -azidométhyl- α -méthyl- α -propiolactone) (PAMMPL). Un copolyéther-ester énergétique thermoplastique élastomère a été préparé en utilisant le polyazoture de glycidyle comme macroinitiateur pour la polymérisation de la BMMPL ou de la CMMPL. L'azoturation du copolyéther-ester résultant a donné un thermoplastique élastomère énergétique qui a fondu à 80-85° C. La polymérisation de l' α -dibromométhyl- α -propiolactone (DBMPL) a donné un polymère qui, après azoturation, a conduit à l'obtention d'un nouveau polymère énergétique qui peut être utilisé comme liant ou dans la synthèse de thermoplastiques élastomères énergétiques. Ce papier décrit principalement la synthèse et la caractérisation de ces nouveaux TPEEs.

14. MOTS-CLÉS, DESCRIPTEURS OU RENSEIGNEMENTS SPÉCIAUX (Expressions ou mots significatifs du point de vue technique, qui caractérisent un document et peuvent aider à le cataloguer. Il faut choisir des termes qui n'exigent pas de cote de sécurité. Des renseignements tels que le modèle de l'équipement, la marque de fabrique, le nom de code du projet militaire, la situation géographique, peuvent servir de mots-clés. Si possible, on doit choisir des mots-clés d'un thésaurus, par exemple le "Thesaurus of Engineering and Scientific Terms (TESTS)". Nommer ce thésaurus. Si l'on ne peut pas trouver de termes non classifiés, il faut indiquer la classification de chaque terme comme on le fait avec le titre.)

thermoplastic, elastomer, energetic, GAP, polyester,

SANS CLASSIFICATION

COTE DE SÉCURITÉ DE LA FORMULE
(plus haut niveau du titre, du résumé ou des mots-cléfs)

Defence R&D Canada

is the national authority for providing
Science and Technology (S&T) leadership
in the advancement and maintenance
of Canada's defence capabilities.

R et D pour la défense Canada

est responsable, au niveau national, pour
les sciences et la technologie (S et T)
au service de l'avancement et du maintien des
capacités de défense du Canada.



www.drdc-rddc.dnd.ca