

Electromagnetic Emissions from an Engineering Model BHT-200 Thruster

31 October 2001

Prepared by

E. J. BEITING and J. E. POLLARD
Propulsion Science and Experimental Mechanics Department
Space Materials Laboratory

and

B. POTE
Busek Company
11 Tech Circle
Natick, MA 01760

Prepared for

THE AIR FORCE RESEARCH LABORATORY
1 Ara Road
Edwards Air Force Base, CA 93524-7013

Engineering and Technology Group

APPROVED FOR PUBLIC RELEASE;
DISTRIBUTION UNLIMITED

This report was submitted by The Aerospace Corporation, El Segundo, CA 90009-2957, under Contract No. F04701-00-C-0009 with the Space and Missile Systems Center, P.O. Box 92960, Los Angeles AFB, CA 90009-2960. It was reviewed and approved for The Aerospace Corporation by P. D. Fleischauer, Principal Director, Space Materials Laboratory. Daron R. Bromaghim was the project officer.

This report has been reviewed by the Public Affairs Office (PAS) and is releasable to the National Technical Information Service (NTIS). At NTIS, it will be available to the general public, including foreign nationals.

This technical report has been reviewed and is approved for publication. Publication of this report does not constitute Air Force approval of the report's findings or conclusions. It is published only for the exchange and stimulation of ideas.

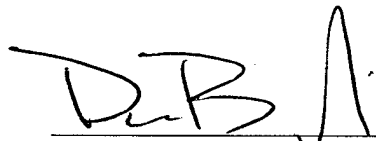
A handwritten signature in black ink, appearing to read 'D.R. Bromaghim', written over a horizontal line.

Daron R. Bromaghim
Project Officer

REPORT DOCUMENTATION PAGE

Form Approved
OMB No. 0704-0188

Public reporting burden for this collection of information is estimated to average 1 hour per response, including the time for reviewing instructions, searching existing data sources, gathering and maintaining the data needed, and completing and reviewing the collection of information. Send comments regarding this burden estimate or any other aspect of this collection of information, including suggestions for reducing this burden to Washington Headquarters Services, Directorate for Information Operations and Reports, 1215 Jefferson Davis Highway, Suite 1204, Arlington, VA 22202-4302, and to the Office of Management and Budget, Paperwork Reduction Project (0704-0188), Washington, DC 20503.

1. AGENCY USE ONLY (Leave blank)	2. REPORT DATE <p style="text-align: center;">July 2001</p>	3. REPORT TYPE AND DATES COVERED
----------------------------------	--	----------------------------------

4. TITLE AND SUBTITLE Electromagnetic Emissions from an Engineering Model BHT-200 Thruster	5. FUNDING NUMBERS F04701-00-C-009
---	---

6. AUTHOR(S) E. J. Beiting and J. E. Pollard	
---	--

7. PERFORMING ORGANIZATION NAME(S) AND ADDRESS(ES) The Aerospace Corporation Technology Operations El Segundo, CA 90245	8. PERFORMING ORGANIZATION REPORT NUMBER TR-2001(1306)-5
--	---

9. SPONSORING/MONITORING AGENCY NAME(S) AND ADDRESS(ES) Space and Missile Systems Center Air Force Materiel Command 2430 E. El Segundo Blvd. Los Angeles Air Force Base, CA 90245	10. SPONSORING/MONITORING AGENCY REPORT NUMBER SMC-TR-02-03
---	--

11. SUPPLEMENTARY NOTES

12a. DISTRIBUTION/AVAILABILITY STATEMENT Approved for public release; distribution unlimited	12b. DISTRIBUTION CODE
---	------------------------

13. ABSTRACT (Maximum 200 words) Radiated electric fields were measured from a BHT-200 Hall thruster from 10 kHz to 18 GHz following MIL-STD 461E (RE102) specifications. The thruster, operated by a laboratory power supply, was located in a fiberglass vacuum tank that was enclosed in a shielded semi-anechoic room. The measurements were made for discharge potentials of 225, 250, 275, and 300 volts and anode flow rates of 0.80, 0.90, 0.94, and 1.0 mg/s (150–240 W discharge power) as well as for several cathode flow rates. For all flow rates and discharge voltages, emission exceeded MIL-STD 461E limits between 10 kHz to 200 MHz. However, for the anticipated thruster operating point (250 V, 0.94 mg/s), electromagnetic emissions remained below MIL-STD 461E limits between 350 MHz and 18 GHz. Generally, electromagnetic emission decreased with increasing anode flow rate below 500 kHz and between 15–30 MHz but increased with anode flow rate between 1–5 MHz. Above 30 MHz, there was no variation of emission with anode flow rate. When the thruster operated at 250 V and 0.94 mg/s anode flow rate, emission decreased with increasing cathode flow rate below 500 kHz. There was no significant variation of emission with discharge voltage above 500 kHz. There was no appreciable difference between spectra taken with the high frequency blocking filter located inside a shielding box next to the thruster and spectra taken with the filter located outside the vacuum chamber. Spectra of the anode current oscillations recorded between 1 kHz and 50 MHz were similar to the radiated spectra and show minimal variation with cathode flow rate.

14. SUBJECT TERMS Electromagnetic emissions, radiated electric fields, MIL-STD 461E, BHT-200 thruster	15. NUMBER OF PAGES 35
--	-------------------------------

	16. PRICE CODE
--	----------------

17. SECURITY CLASSIFICATION OF REPORT UNCLASSIFIED	18. SECURITY CLASSIFICATION OF THIS PAGE UNCLASSIFIED	19. SECURITY CLASSIFICATION OF ABSTRACT UNCLASSIFIED	20. LIMITATION OF ABSTRACT
---	--	---	----------------------------

Abstract

Radiated electric fields were measured from a BHT-200 Hall thruster from 10 kHz to 18 GHz following MIL-STD 461E (RE102) specifications. The thruster, operated by a laboratory power supply, was located in a fiberglass vacuum tank that was enclosed in a shielded semi-anechoic room. The measurements were made for discharge potentials of 225, 250, 275, and 300 volts and anode flow rates of 0.80, 0.90, 0.94, and 1.0 mg/s (150–240 W discharge power) as well as for several cathode flow rates. For all flow rates and discharge voltages, emission exceeded MIL-STD 461E limits between 10 kHz to 200 MHz. However, for the anticipated thruster operating point (250 V, 0.94 mg/s), electromagnetic emissions remained below MIL-STD 461E limits between 350 MHz and 18 GHz. Generally, electromagnetic emission decreased with increasing anode flow rate below 500 kHz and between 15–30 MHz but increased with anode flow rate between 1–5 MHz. Above 30 MHz, there was no variation of emission with anode flow rate. When the thruster operated at 250 V and 0.94 mg/s anode flow rate, emission decreased with increasing cathode flow rate below 500 kHz. There was no significant variation of emission with discharge voltage above 500 kHz. There was no appreciable difference between spectra taken with the high frequency blocking filter located inside a shielding box next to the thruster and spectra taken with the filter located outside the vacuum chamber. Spectra of the anode current oscillations recorded between 1 kHz and 50 MHz were similar to the radiated spectra and show minimal variation with cathode flow rate.

Contents

1. Purpose and Scope of Tests.....	1
2. EMC Facility Configuration	3
3. Radiated Electric Field Measurements.....	9
4. Discharge Current Oscillations	19
5. Summary	21
6. References.....	22
Appendix I: Log of Electromagnetic Data.....	23
Appendix II: Operating Points.....	27
Appendix III: Receiver and Antenna Specifications	31

Figures

Figure 1. Layout of the Facility	3
Figure 2. BHT-200 on Water Cooled Aluminum Mounting Plate	4
Figure 3. Scale Drawing of Anechoic Room.....	5
Figure 4. EMC Facility Correction Terms.....	6
Figure 5. Shielding configuration for the BHT-200	7
Figure 6. Interior View of RFI Box	8
Figure 7. Schematic of Low Pass Filter.....	8
Figure 8. HP 8572A Receiver System.....	9
Figure 9. Positions of the Four Antennas	13
Figure 10. BHT-200 radiation at 225 V, Vertical Polarization.....	14
Figure 11. BHT-200 radiation at 250 V, Vertical Polarization.....	14
Figure 12. BHT-200 radiation at 275 V, Vertical Polarization.....	15
Figure 13. BHT-200 radiation at 300 V, Vertical Polarization.....	15
Figure 14. BHT-200 radiation at 225 V, Horizontal Polarization	16
Figure 15. BHT-200 radiation at 250 V, Horizontal Polarization	16
Figure 16. BHT-200 radiation at 275 V, Horizontal Polarization	17
Figure 17. BHT-200 radiation at 300 V, Horizontal Polarization	17
Figure 18. BHT-200 radiation with Cathode Flow Variation.....	18
Figure 19. BHT-200 radiation for Two Filter Positions	18
Figure 20. Spectra of Current Oscillations	20

Tables

Table 1. Main Test Matrix	1
Table 2. Cathode Flow Test Matrix.....	2
Table 3. RE102 Electromagnetic Band Parameters.....	10
Table 4. List of Composite Electric Field Spectra.....	11
Table 5. Spectrum Analyzer Bandwidths for Discharge Current	19

1. Purpose and Scope

Radiated electric fields from 10 kHz to 18 GHz were measured from an engineering model BHT-200 thruster [1]. The fields were recorded following MIL-STD 461E specifications. The thruster was operated with a laboratory power supply (through a high frequency blocking filter) and a laboratory xenon flow controller. Spectra of the anode current oscillations were also recorded for several operating conditions.

The purpose of the tests was to create a survey of the radiated field as a function of discharge voltage, anode flow rate, cathode flow rate, and discharge filter configuration. The main study measured emissions for the operating points shown in Table 1. This matrix was repeated nine times (for five frequency intervals and two antenna polarizations) to generate a complete data set. The cathode flow rate was kept at 8% of the anode flow rate and the magnetic field was adjusted to minimize the discharge current. The powers listed in Table 1 are examples of the measured values. The thruster would not operate reliably at setting No. 17.

Table 1. Main Test Matrix

No.	Discharge Voltage	Discharge Current (A)	Power (W)	Anode Flow (mg/s)	Cathode Flow (mg/s)
1	OFF	0.67	0	OFF	OFF
2	225	0.67	151	0.8	0.064
3	250	0.67	168	0.8	0.064
4	275	0.67	184	0.8	0.064
5	300	0.77	203	0.8	0.064
6	225	0.77	173	0.9	0.072
7	250	0.77	190	0.9	0.072
8	275	0.77	209	0.9	0.072
9	300	0.81	240	0.9	0.072
10	225	0.81	185	0.94	0.074
11	250	0.81	205	0.94	0.074
12	275	0.81	226	0.94	0.074
13	300	0.86	243	0.94	0.074
14	225	0.86	196	1.0	0.080
15	250	0.86	218	1.0	0.080
16	275	0.86	239	1.0	0.080
17	300	--	--	1.0	0.080

A second study measured the emission from the thruster for setting No. 11 in Table 1 while the cathode flow rate was varied. The test matrix for this study is shown in Table 2. The thruster would not operate at setting No. 3 of Table 2. Finally, a third study repeated operating point No. 11 in Table 1 with the discharge filter components outside the vacuum system.

Table 2. Cathode Flow Test Matrix

No.	Discharge Voltage	Anode Flow Rate (mg/s)	Cathode Flow Rate (mg/s)	Power (W)
1	250	0.94	0.075	202.5
2	250	0.94	0.0564	202.5
3	250	0.94	0.0376	0
4	250	0.94	0.094	202.5
5	250	0.94	0.1128	202.5
6	OFF	OFF	OFF	0

2. Facility and Configuration

The Aerospace Corporation EMC facility comprises three components. The first is a small, all-dielectric vacuum tank that houses the thruster. This fiberglass tank is transparent to electromagnetic radiation and mates to a large vacuum stainless steel chamber that has a xenon pumping capacity of 165,000 liter/sec. For this test, the pumping speed was 95,000 l/s because only three of the five cryo-pumps were used. The second component is a semi-anechoic room that surrounds the dielectric tank to shield the thruster from the ambient electromagnetic environment. This room is lined with 0.6 m high pyramids that absorb radiation from the thruster at frequencies higher than 80 MHz in order to mitigate reflections from the metallic walls of the room. The final component is a calibrated receiver that records the radiation emanating from the thruster. The receiver connects to series of antennas through a panel in the semi-anechoic room using a two-section semi-rigid cable with known attenuation. The arrangement of these components is shown in Figure 1.

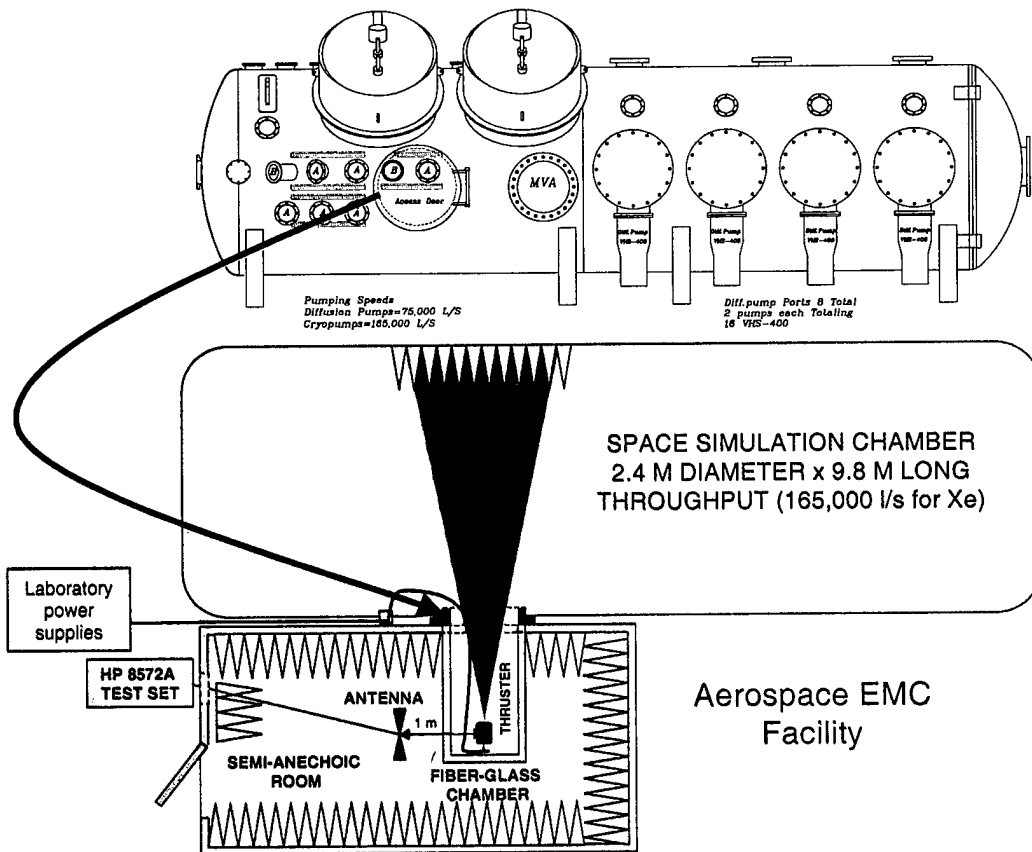

Figure 1. Layout of the facility used to measure electromagnetic emissions from electric thrusters.

The cylindrical dielectric vacuum tank is 0.9 m in diameter and 1.8 m in length. This small size allows antennas to be placed outside the vacuum to the side and behind the thruster at a distance of 1 m from the thruster as required by MIL-STD 461/462. Because the antennas are placed outside the vacuum, there is no concern with antenna plasma interaction. Additionally, the antennas required for recording emission

between 10 kHz and 18 GHz (or higher frequencies) can be positioned sequentially, eliminating the possibility of antenna-antenna interaction.

The pyramid-lined 5 m by 3 m by 3 m semi-anechoic room surrounding the fiberglass tank provides >100 dB shielding from 14 kHz to 18 GHz (MILSTD 285 and NSA 65-5 compliant) and has an interior wall absorption of <-6 dB (80-250 MHz) and -30 dB above 250 MHz. A modular design with a free-standing ceiling allows sections of the walls of the room to be removed to allow complete access to the main vacuum tank when EMC measurements are not required. The vacuum tank that houses the thruster, as well as all bolts, fittings, cooling lines, and support fixtures that are located inside the semi-anechoic room, are fabricated of electrically non-conducting materials.

As shown in Figure 2, the BHT-200 thruster was mounted on a water-cooled aluminum plate approximately the same size as the bottom of the thruster to ensure that little electromagnetic scattering profile is added to the assembly. The water-cooled plate remained below 25° C for all operating conditions. All support structures, fixtures, and tubing attached to the mounting plate were nonmetallic. As indicated in Figure 3, the back of the thruster was less than 25 cm from the inside surface of the end cap of the dielectric tank; the axis of the thruster was aligned along the axis of the dielectric tank. Shielded cables and propellant lines were routed along the bottom of the dielectric chamber underneath a fiberglass plate to a vacuum feed-through in the main chamber.

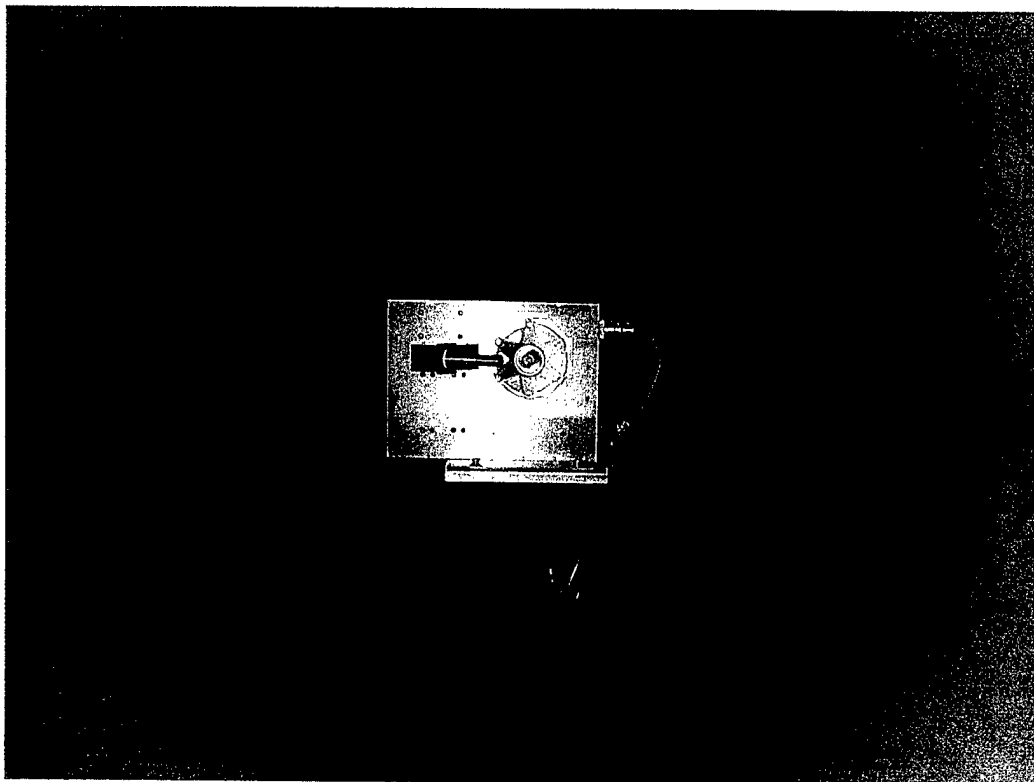

Figure 2. BHT-200 on water-cooled aluminum mounting plate with filter box behind the thruster. The back of the fiberglass tank is removed, allowing the absorbing pyramids in the anechoic room to be seen.

The plume of the thruster exhausted into the main vacuum tank, terminating on a beam dump comprising a series of aluminum pyramids 0.6 m high covered with flexible graphite to reduce sputtering by the high-energy ions. The pyramidal design of this conducting beam dump serves to reduce scattering of electromagnetic radiation from the thruster by the main tank at frequencies > 80 MHz.

Electromagnetic radiation was sensed by antennas that meet MIL-STD 461/462 requirements. Signals were routed using calibrated cables through a panel in the anechoic room to a Hewlett Packard Model 8572A microwave receiver. This receiver was controlled by a computer that also stored the data for later processing by custom software.

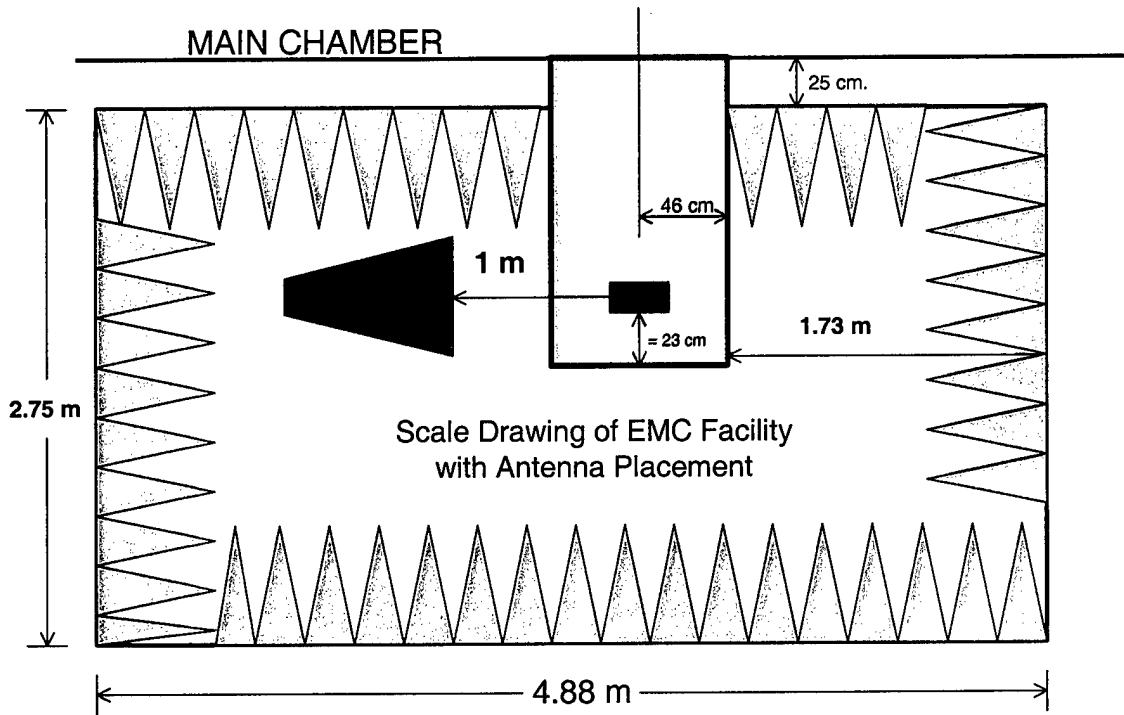

Figure 3. Scale drawing of anechoic room showing antenna and thruster placement.

The small anechoic room and the fiberglass vacuum chamber distort the electromagnetic spectrum emitted from a thruster. The anechoic enclosure, with its cross-sectional dimensions of 3 m by 3 m, is expected to have resonance frequencies near 50 MHz. Filling the enclosure with absorbing pyramids lowers the Q of the room, which increases the bandwidth and lowers the resonance frequencies. The 0.6 m anechoic pyramids have a quarter wavelength that corresponds to a frequency of 125 MHz and most effectively absorb radiation above this frequency. The transmission coefficient of an S2 fiberglass wall of 1 cm thickness is predicted to undergo sinusoidal oscillations between 0 and -3 dB with a period of 7.5 GHz.

To quantify and correct for these room and tank perturbations, the emission from a 15 cm long stub radiator was measured and compared to its calculated emission expected in free space at a distance of 1 m. The distortion terms for the two receiving antenna polarizations obtained through this procedure are shown in Figure 4 for frequencies between 10 and 200 MHz. The corrections vary between -30 and +30 dB and are stronger for the vertically polarized receiving antennas than for the horizontally polarized antennas, but are significant for both polarizations. These distortion terms can be added to the measured

fields to obtain a better measure of the true emissions from the thrusters. Details of the procedure and additional information on the EMC facility have been published [2].

With the thruster operating at nominally 200W (250V, 0.8 A, total xenon flow of 1 mg/s), the pressure measured in main chamber was 5.6×10^{-6} T (corrected to 1.95×10^{-6} T for Xe). Pressures behind the thruster in the dielectric chamber were about two times higher than the values measured near the cryo-pump.

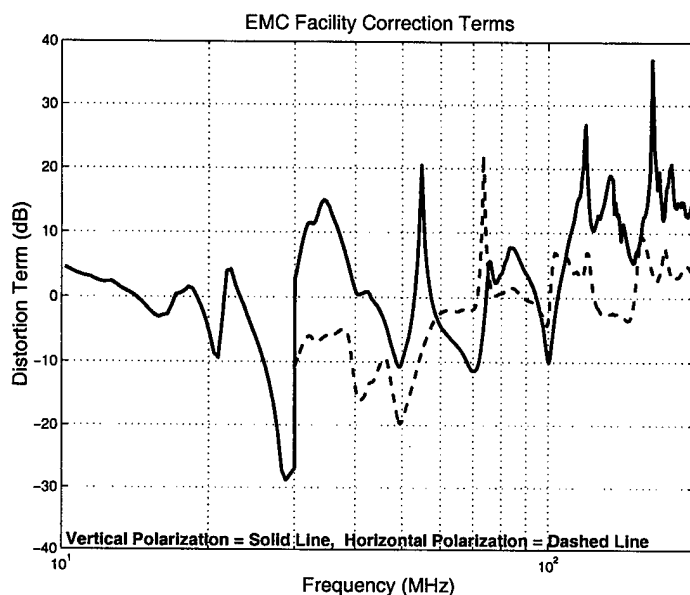

Figure 4. EMC facility correction terms for vertical and horizontally polarized receiving antennas. These values can be added to the (dB) electric field data to correct for room resonance.

Care was taken to isolate the current oscillations from the thruster using an RFI box attached to the back of the thruster in the approximate position that will be occupied by the PPU. Double-shielded cables were routed from this RFI box under a fiberglass floor in the fiberglass tank through the wall of main vacuum chamber to the power supplies. This configuration is shown in Figure 5.

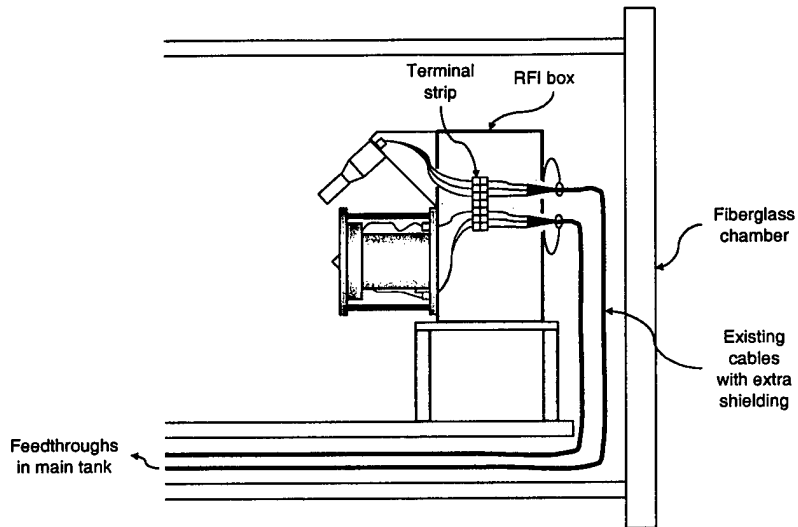

Figure 5. Shielding configuration for the BHT-200 tests. Filter components in the RFI box are not shown.

A discharge filter was located in the RFI box for the main series of tests (Tables 1 and 2). The placement of this filter in the RFI box is shown in Figure 6 and the circuit is given in Figure 7. This filter was later removed and placed outside the vacuum and the anechoic room before the power supplies. The latter arrangement permits the anode current oscillations to be measured.

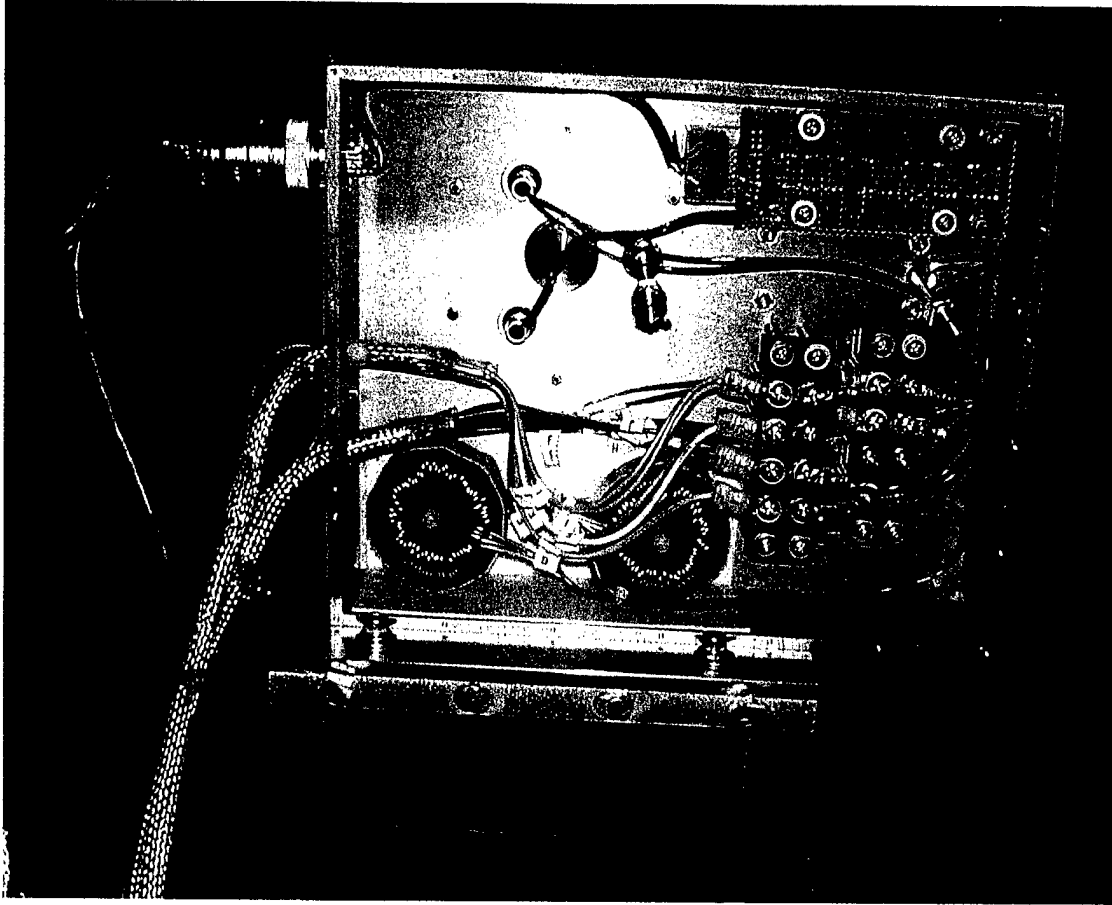

Figure 6. View of interior of RFI box, shielded cables and discharge (low-pass) filter components mounted on water cooled plate.

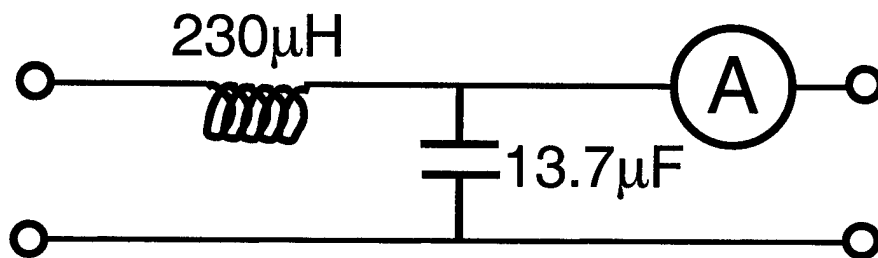

Figure 7. Schematic of low-pass filter used to block high-frequency current oscillations from power cables.

3. Radiated Electric Field Measurements

All radiated field measurements were made using HP 85689A software, a recently calibrated HP 8572A Option 462 receiver, MIL-STD 461/462 antennas, and cables with known (measured) attenuation. The specifications and characteristics of these components are presented in Appendix III. An HP 8447F dual preamplifier, visible in Figure 8, could be added to the 8572A receiver to increase the sensitivity by 25 dB between 100 kHz and 1 GHz. This additional gain is required to meet the sensitivity requirements specified by MIL-STD 461E. However, for the signal levels encountered here, this additional gain was not needed. Therefore, a preamplifier was not used in order to maintain a large dynamic range.

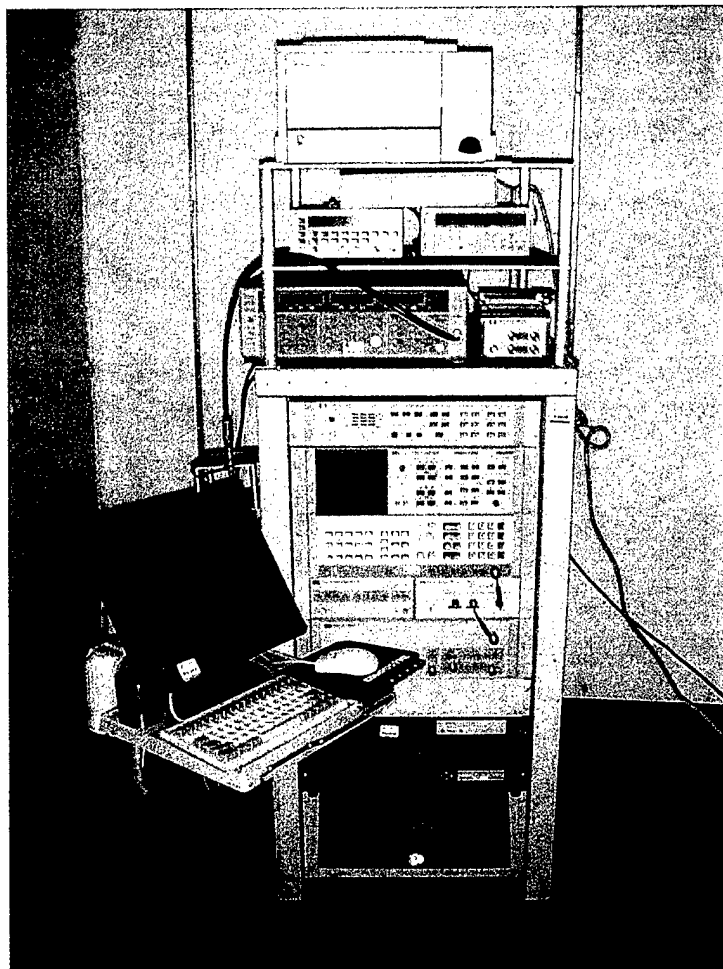

Figure 8. HP 8572A receiver, HP 8447F dual preamplifier on top right of the receiver, and built-in computer console used for the measurements. A Wiltron Model 6617B (10 MHz - 8 GHz) synthesized sweep generator on top of the receiver rack was used to verify the operation of the receiver through the antennas.

Measurements of the radiative electric field were made following the specifications in RE102 of MIL-STD 461E. The bands, resolution bandwidths (RBW), and antennas used are listed in Table 3. Also listed in Table 3 are constant dB values that must be added to these data if they are to be compared with data that are displayed as dB $\mu\text{V}/\text{m}/\text{MHz}$ as required by the older 461/462C specifications (see discussion at end of this section).

The emission from a band for each element in the test matrix and the background emission from that band were measured before reconfiguring for the next band. Calibration of the receiver was performed for all bands at the beginning of each day's measurements. The exact sequence of the measurements is given in the data log in Appendix I.

Table 3. RE102 Electromagnetic Band Parameters

461E Bands	461E Wavelength Ranges	461E RBW (kHz)	461C RBW (kHz)	461C/E Term (dB)*	Antenna	Ant Polari zation	L (m)	Far Field Distance**
10 - 150 kHz	30 - 2 km	1	3	60	Active Rod	V	1	90km - 6 km
0.15 - 30 MHz	2000 - 10m	10	3, 10, 30	40	Active Rod	V	1	6000m - 10m
30 - 200 MHz	10 - 1.5m	100	30, 100	20	Biconical	V,H	1.5	10m - 4.5 m
0.2 - 1 GHz	1.5m - 30cm	100	300	20	DR Horn 1	V,H	1	4.5 m 7m
1 - 18 GHz	30 - 1.67 cm	1000	3000	0	DR Horn 2	V,H	0.20	1m - 5m

*Value that must be added to data taken using 461E displayed as dB μ V/m to compare with 461C broadband data that are displayed as dB μ V/m/MHz if the bandwidth of the emission is greater than the resolution bandwidths and noise is purely coherent (see discussion in text).

**Greater of 3λ or $2L^2/\lambda$ where L is the largest antenna dimension.

All measurements were made with the antennas placed 1 meter to the side of the thruster (see Figure 9). At this distance, all measurements were made in the near field as indicated by the last column in Table 3. The counterpoise of the active rod antenna was grounded to the floor of the semi-anechoic room using a 12 in wide, 5 mil copper sheet. The use of an active rod obviated the need for band switching for the low frequency measurements. The height of the biconical and double ridge horn antennas was 120 cm above the grounded floor.

The composite electric field spectra are presented in Figures 10–19; Table 4 lists the test parameters for each spectrum. Each figure displays the data, background, and 461E limit line. Data from the main test matrix (Figures 10 - 17) were grouped by flow rate rather than by discharge voltage because there was less variation with discharge voltage. The horizontally polarized data begins at 30 MHz because the rod antenna can be used only in vertical polarization. All values displayed above 85 dB μ V/m on these figures are inaccurate. The true field values are less than the values shown.

Observations from these spectra include:

a. For vertically polarized receiving antennas:

1. Between 10 kHz and 200 MHz, broadband emissions exceed MIL-STD 461E limits by 20–60 dB μ V/m for all flow rates and discharge voltages.
2. Near 300 MHz, emission was 5 -10 dB μ V/m above MIL-STD 461E limits.
3. Emission decreased with increasing anode flow rate below 500 kHz and between 15–30 MHz but emission increased with flow rates between 1–5 MHz; above 30 MHz there was no variation of emission with anode flow rate except at the 300 V discharge voltage, which had higher emission at the highest flow rate obtainable (0.94 mg/s) at that voltage.
4. The emission variation with discharge voltage was less pronounced: below 500 kHz, emission from the thruster operating at the lowest voltage discharge (225 V) was about 10 dB μ V/m lower

than when the thruster was operating at the highest voltage (300 V); there was no significant variation of emission with discharge voltage above 500 kHz.

5. Emission decreased with increasing cathode flow rate below 500 kHz with a maximum variation of 10 dB μ V/m; between 500 kHz and 30 MHz there was no significant variation in emission with cathode flow rate.
6. There was no significant difference between spectra taken with the low-pass filter inside the RFI box next to the thruster and spectra taken with the filter outside the vacuum chamber.

b. For horizontally polarized receiving antennas:

1. From 30–350 MHz broadband emissions exceed MIL-STD 461E limits by 5–50 dB μ V/m for all flow rates and discharge voltages.
2. Between 30–200 MHz, there was no significant variation in emissions with anode flow rate.
3. Between 200–350 MHz, emission was 5 -10 dB μ V/m lower for 0.80 mg/s anode flow rate than for the higher flow rates for all discharge voltages.
4. Between 2–4 GHz for a discharge voltage of 300 V, emission was approximately 10 dB μ V/m higher for the 0.90 mg/s anode flow rate than the other two flow rates.

Table 4. List of Composite Electric Field Spectra

Figure No.	Variable	Discharge Voltage (V)	Anode Flow Rate (mg/s)	Antenna Polarization	Frequency Range
10	Anode Flow	225	0.8, 0.9, 0.94, 1.0	Vertical	10kHz – 18 GHz
11	Anode Flow	250	0.8, 0.9, 0.94, 1.0	Vertical	10kHz – 18 GHz
12	Anode Flow	275	0.8, 0.9, 0.94, 1.0	Vertical	10kHz – 18 GHz
13	Anode Flow	300	0.8, 0.9, 0.94	Vertical	10kHz – 18 GHz
14	Anode Flow	225	0.8, 0.9, 0.94, 1.0	Horizontal	30 MHz – 18 GHz
15	Anode Flow	250	0.8, 0.9, 0.94, 1.0	Horizontal	30 MHz – 18 GHz
16	Anode Flow	275	0.8, 0.9, 0.94, 1.0	Horizontal	30 MHz – 18 GHz
17	Anode Flow	300	0.8, 0.9, 0.94	Horizontal	30 MHz – 18 GHz
18	Cathode Flow	250	0.94	Vertical	10kHz – 30 MHz
19	Filter Position	250	0.94	Vertical	10kHz – 18 GHz

Caution should be exercised when comparing these data with measurements made using MIL-STD 461C or earlier specifications. Under these earlier provisions, broadband measurements are taken with an unspecified (but specific) bandwidth and then normalized to a 1 MHz bandwidth; narrow band measurements are also acquired but are not displayed normalized to a frequency bandwidth. MIL-STD 461E specifies bandwidths at a 6 dB width and requires that data not be displayed normalized to a frequency bandwidth. When the spectra of the (noise) signals are broader than the resolution bandwidths of the spectrum analyzer, increasing the bandwidth of the analyzer increases the signal registered. If the

noise is purely incoherent (Gaussian noise), the noise displayed increases linearly with bandwidth; a 10x increase in bandwidth will lead to a 10 dB increase in the displayed signal. If, however, the noise is coherent (random impulse signals), the signal increases with the square of the bandwidth and a 10x increase in bandwidth leads to a 20 dB increase in signal. For example, if broadband data were taken with a bandwidth of 1 kHz and displayed as field strength per MHz, assuming broadband coherent noise, 60 dB would be added to the displayed signal. High noise from these thrusters is principally coherent but not purely so.

There is another consideration. All MIL-STD 461 revisions require using instrument filters whose widths are defined 6 dB down from center (peak) transmission, but many instruments are configured with 3 dB filters. These 3 dB filters are broader than filters defined at the 6 dB level by a factor of approximately 1.5 if the filters have similar standard band shapes. If data is taken using a 3 dB instrument, the bandwidth of this instrument must be redefined to be in accordance with MIL-STD 461. This requires a reduction in the displayed data by an amount that depends on the character of the noise as discussed above. So comparison of data taken under different specifications depends on the character of the noise, bandwidths, bandwidth definitions, and even somewhat on band shapes. It is for these reasons that 461E specifies specific bandwidths and bandwidth definitions, and requires no bandwidth normalization.

Active Rod

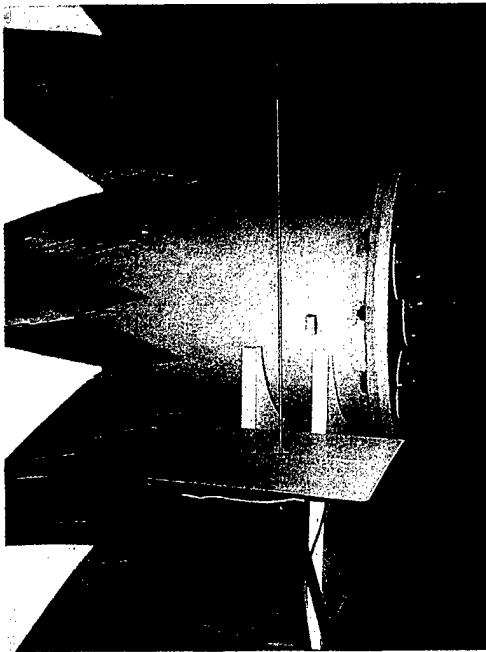

Biconical, Vertical

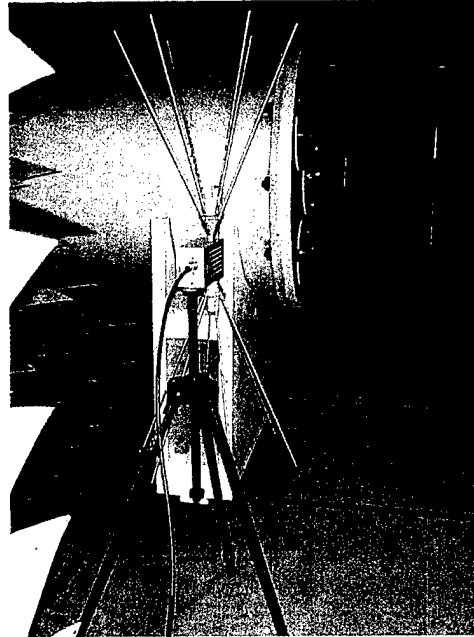

DR Horn 1, Horizontal

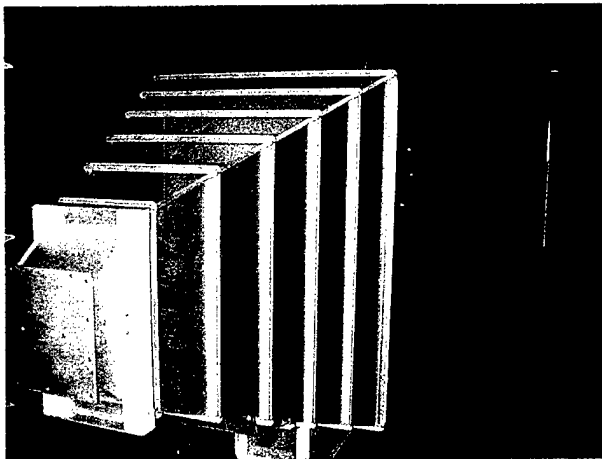

DR Horn 2, Horizontal

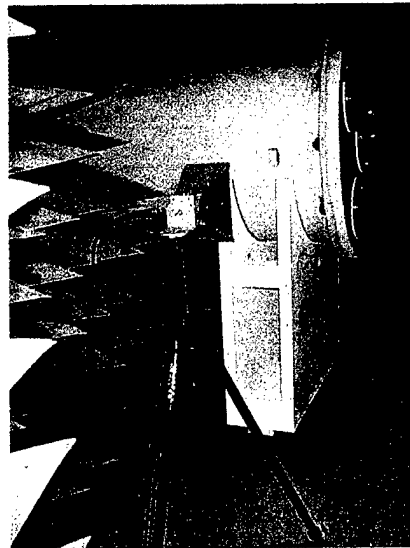

Figure 9. Positions of the four antennas used for the ML-STD 461E measurements.

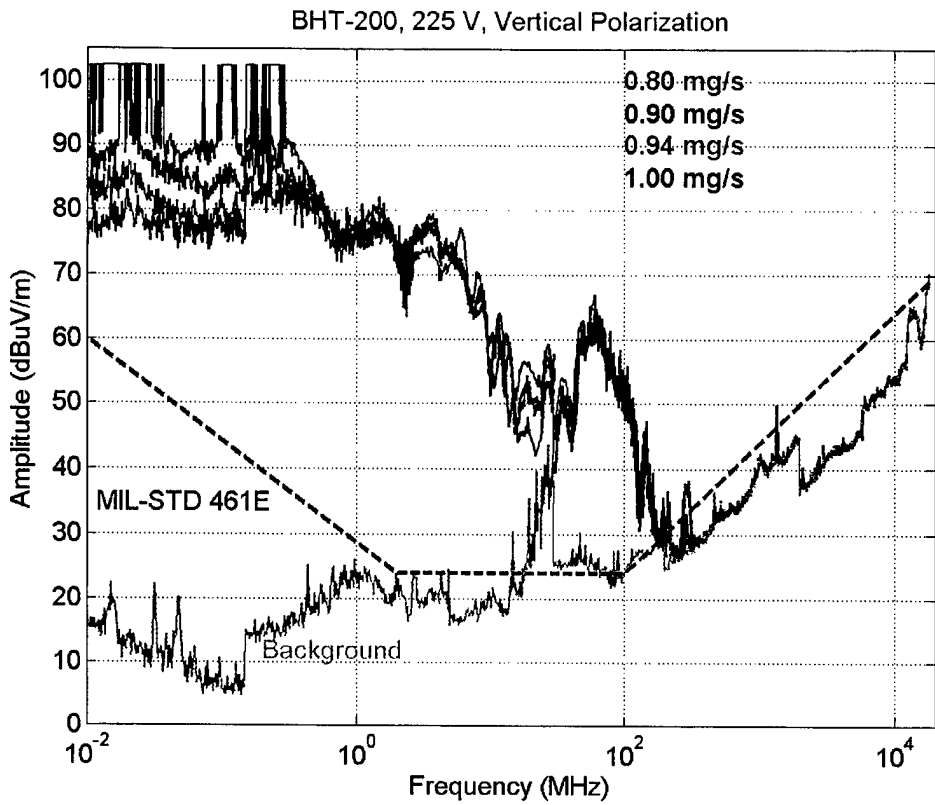

Figure 10. BHT-200 radiation at 225 V and four anode flow rates, vertical polarization.

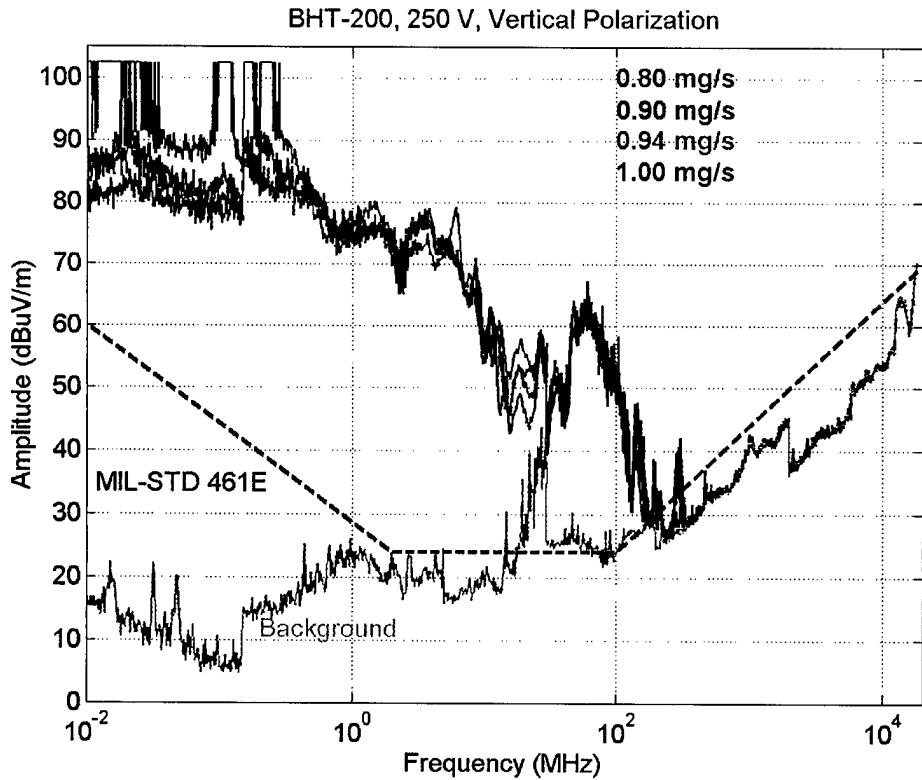

Figure 11. BHT-200 radiation at 250 V and anode flow rates, vertical polarization.

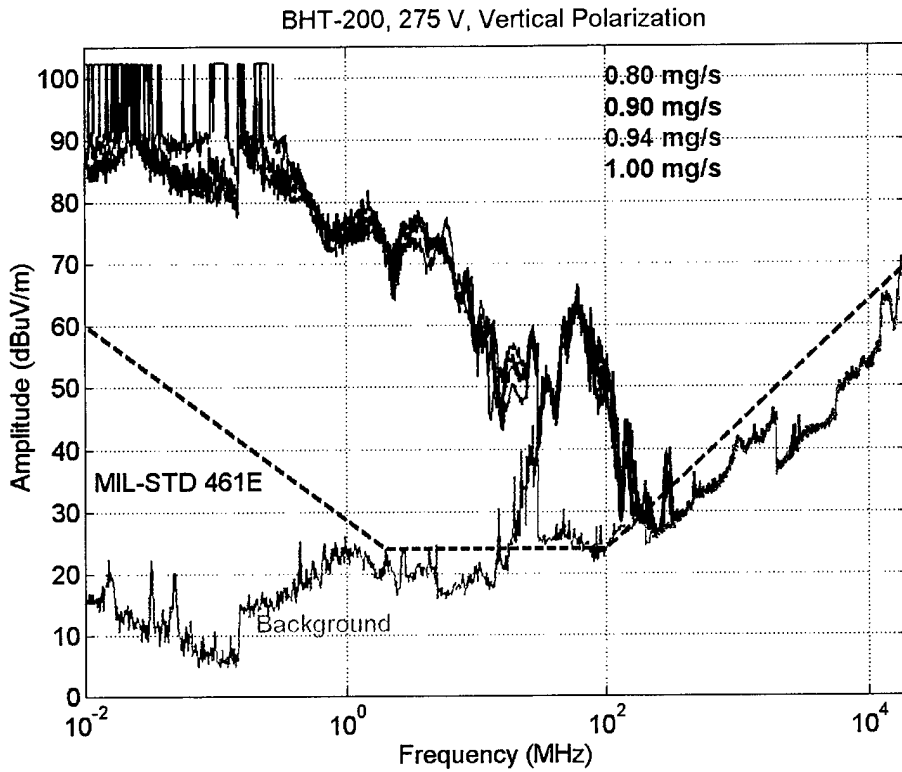

Figure 12. BHT-200 radiation at 275 V and four anode flow rates, vertical polarization.

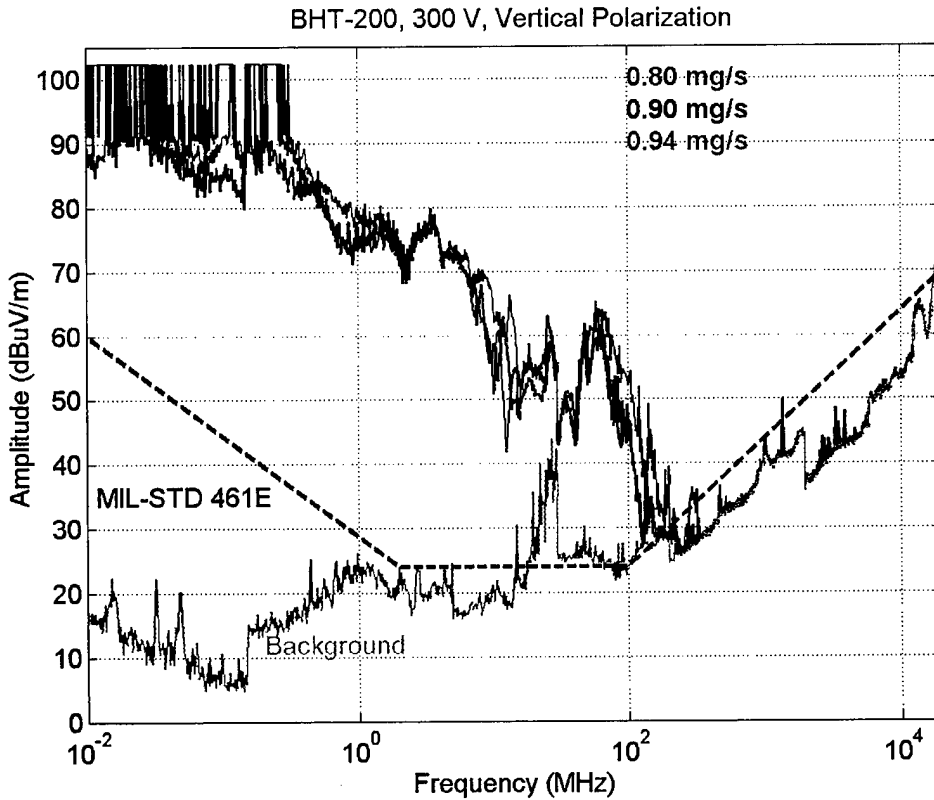

Figure 13. BHT-200 radiation at 300 V and four anode flow rates, vertical polarization.

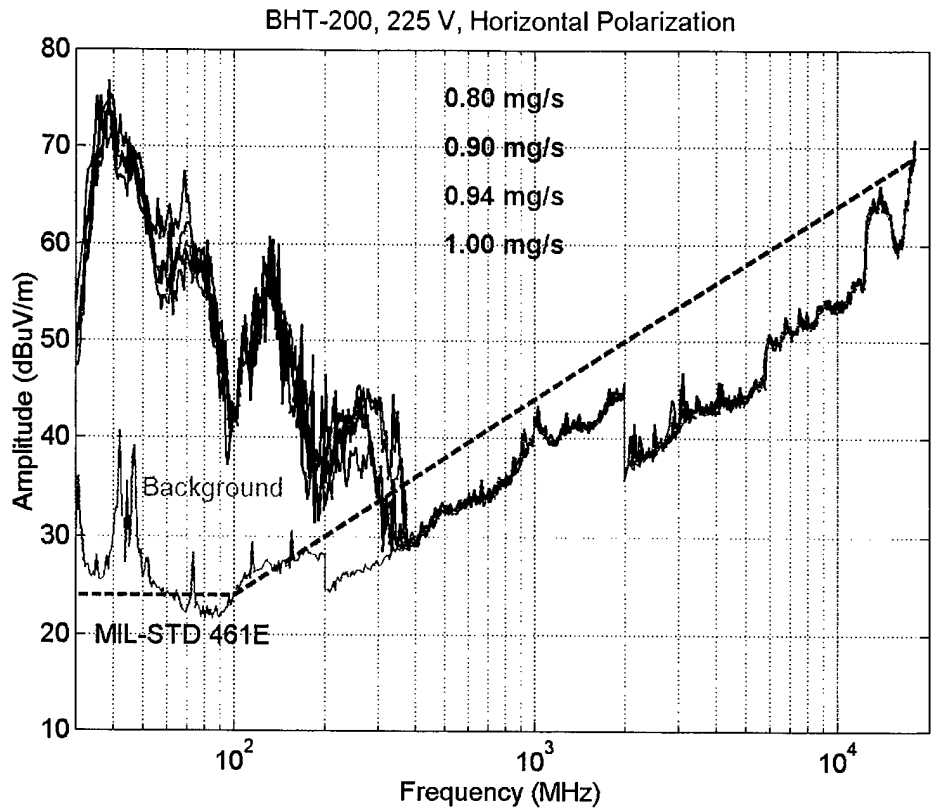

Figure 14. BHT-200 radiation at 225 V and four anode flow rates, horizontal polarization.

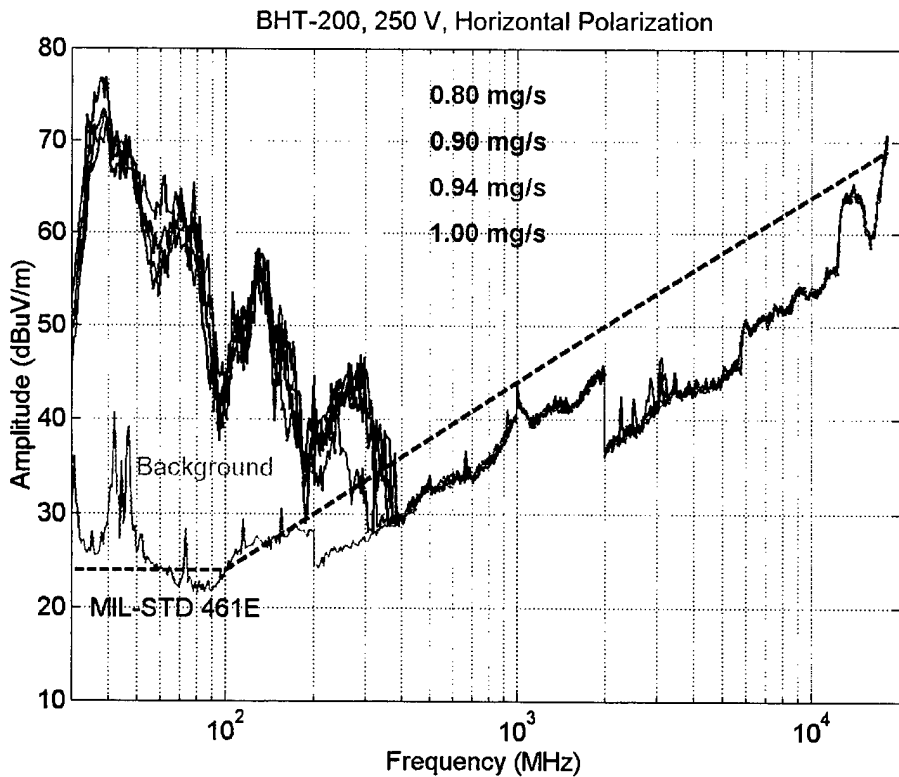

Figure 15. BHT-200 radiation at 250 V and four anode flow rates, horizontal polarization.

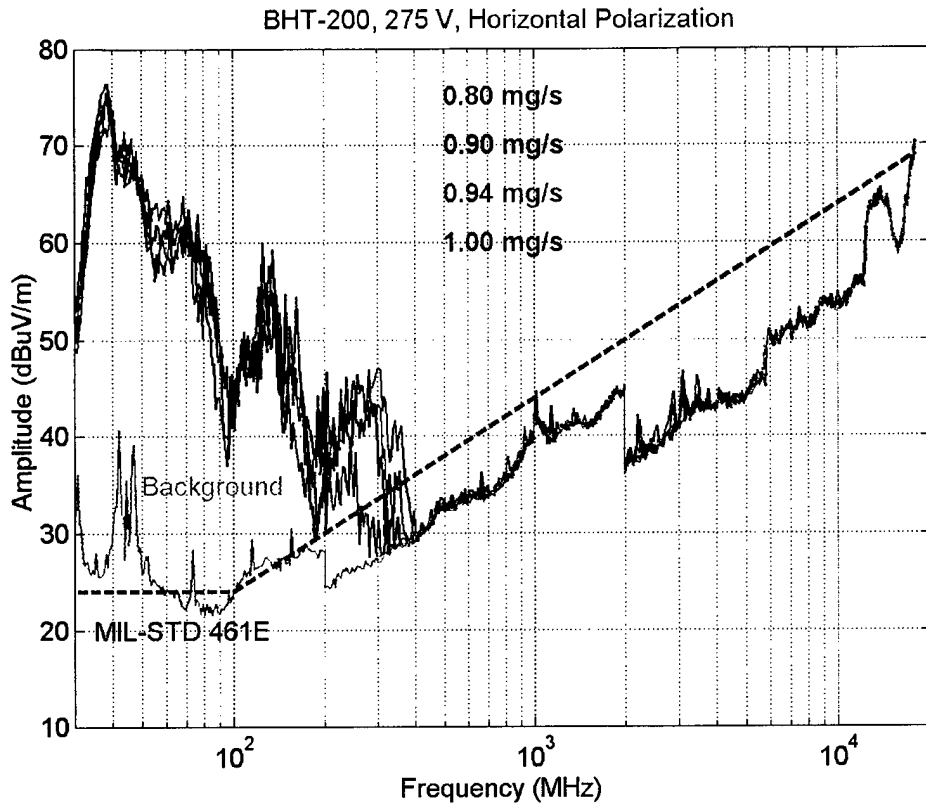

Figure 16. BHT-200 radiation at 275 V and four anode flow rates, horizontal polarization.

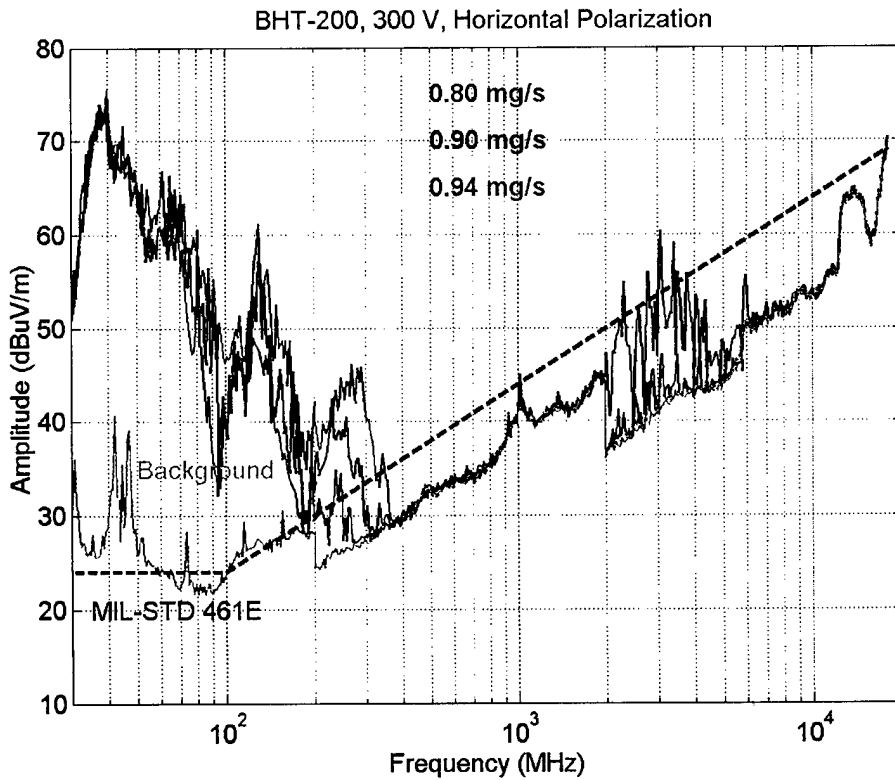

Figure 17. BHT-200 radiation at 300 V and four anode flow rates, horizontal polarization.

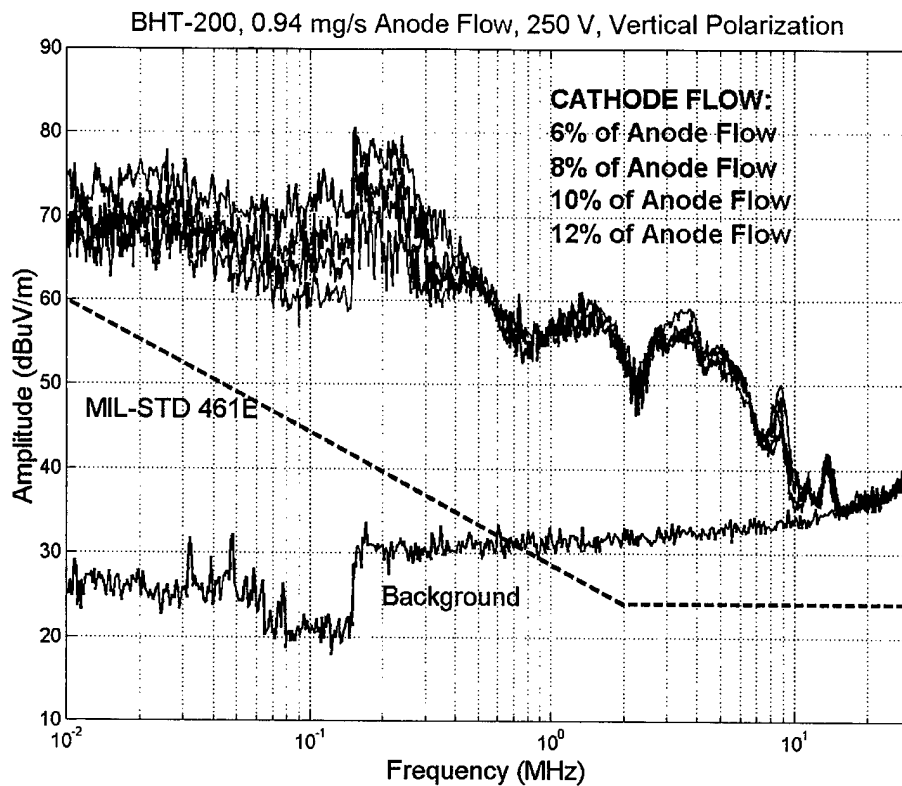

Figure 18. BHT-200 radiation at 250 V and four cathode flow rates, vertical polarization.

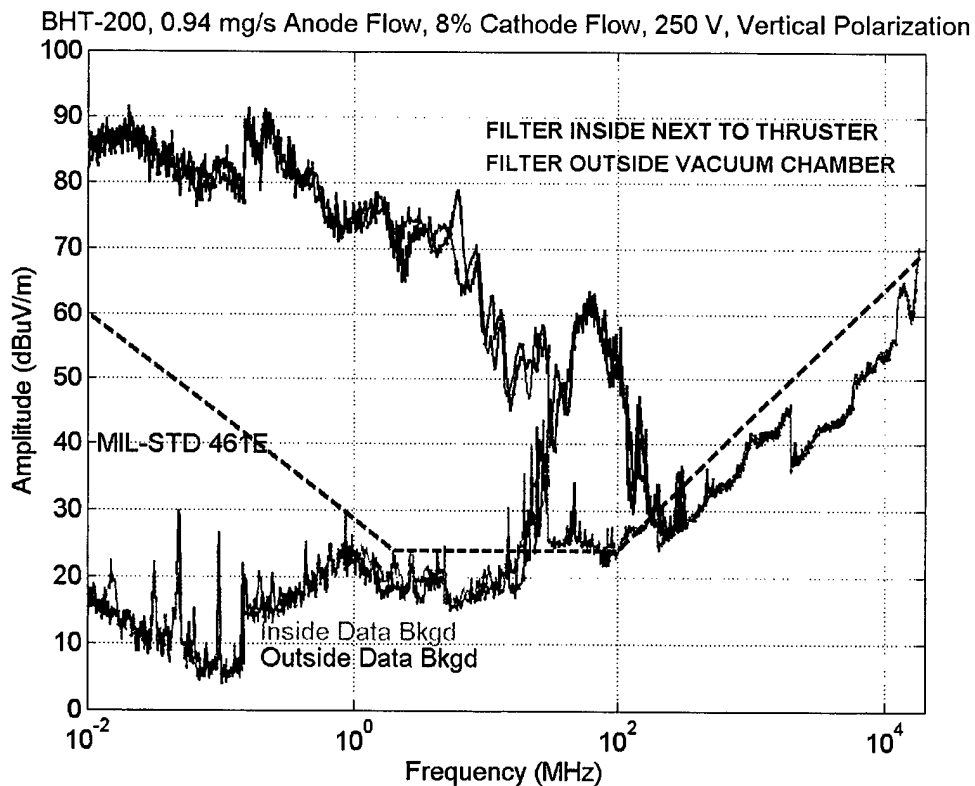

Figure 19. BHT-200 radiation at 250 V for two filter positions, vertical polarization.

4. Characterization of Discharge Current Oscillations

When the discharge filter was moved from the RFI box to a position outside the vacuum chamber, the discharge current oscillations for four different cathode flow rates were measured. Discharge current oscillations of Hall thrusters are often linked to their radiated emissions.

A Tektronics A6302 clip-on current probe with a 50 MHz bandwidth was attached to an exposed section of the anode cable. The signal from the current probe was fed to a Tektronics AM503B preamplifier connected to a Tektronix 2755AP spectrum analyzer through a RC high-pass filter with a cutoff frequency of 530 Hz. Prior to taking these measurements, the probe was calibrated in-house between 30 Hz and 10 MHz. The measured transfer impedance was 3.3V/A and found to be independent of frequency.

For each thruster operating point the signal was sampled in one-decade frequency increments. A LabView program loaded spectrum analyzer settings for each frequency band and then stored the 1000 data points. After all spectral segments were collected, the cathode flow rate was varied and the measurements repeated. The resolution bandwidth in each band was chosen automatically by the spectrum analyzer. These settings were identical for all of the test runs and are summarized in Table 5. The spectrum analyzer's video bandwidth was used to reduce the noise without changing the envelope of the spectrum. The video bandwidths used are also listed in Table 5.

Table 5. Discharge Current Analyzer Bandwidths

Frequency band	Resolution Bandwidth	Video Bandwidth
1 kHz – 11 kHz	100 Hz	3.3 Hz
10 kHz -110 kHz	1 kHz	33 Hz
100 kHz – 1.1 MHz	10 kHz	330 Hz
1 MHz – 11 MHz	100 kHz	3.3 kHz
10 MHz – 110 MHz	1 MHz	33 kHz

The data were post-processed by normalizing the measured signal by the corresponding resolution bandwidth and then correcting for the probe impedance. The graphs of the data are presented in Figure 20 and represent dBmA per unit resolution bandwidth. These were obtained with the thruster operating at 200 W (250 V, 0.8 A discharge current). A peak of -15 dBmA/Hz occurred near 20 kHz and decreased about 5% as the cathode flow rate increased from 6 to 12 % of the anode flow rate. No significant changes were observed in the spectrum as the cathode mass flow was varied. These spectra of the anode current are similar to the radiated spectra.

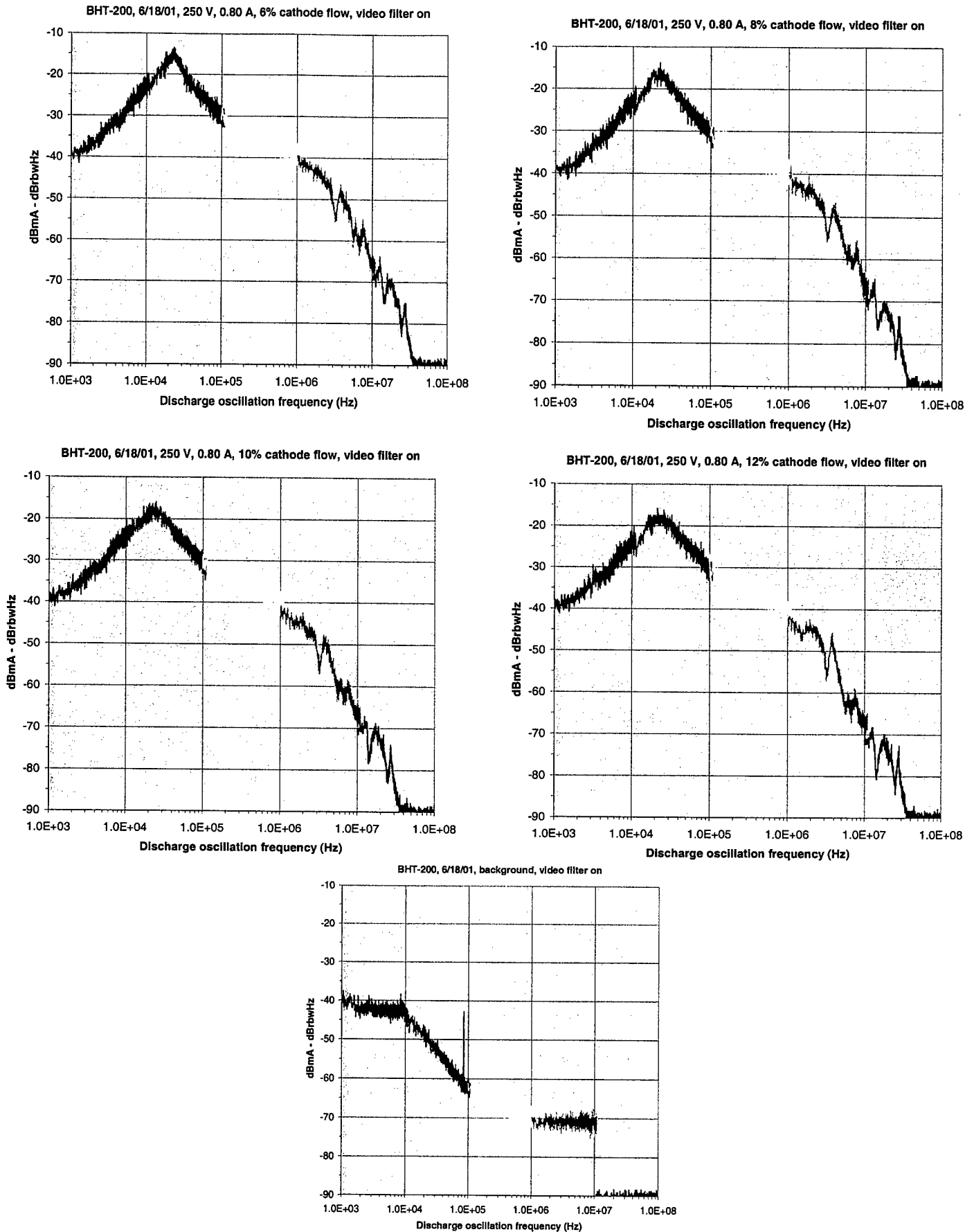

Figure 20. Spectrum of BHT-200 current oscillations (200 W for four cathode flows. Bottom plot is power off).

6. Summary

Electromagnetic emissions from Hall thrusters are linked to plasma instabilities and are not a strong function of the power of the thruster. For the BHT-200, as is typical of most Hall thrusters, the emissions between 10 kHz and a few hundred MHz greatly exceed MIL-STD 461E limits. In general, the more stable the anode current, the lower the radiated emission, which is clear from the data presented here for the BHT-200. It is not uncommon for Hall thrusters to exhibit emissions above 461E limits at much higher frequencies (> 500 MHz). These higher-frequency emissions usually occur in isolated frequency intervals and can be troublesome for some communication bands. The BHT-200 exhibited no emissions above 461E limits above 350 MHz at its anticipated operating point.

7. References

1. V. Hruby, J. Monheiser, B. Pote, C. Freeman, and W. Connolly, *Low Power, Hall Thruster Propulsion System*, IEPC-99-092, 26th International Electric Propulsion Conference, Kitakyushu, Japan, 17–21 October 1999.
2. E. J. Beiting, *Design and Performance of a Facility to Measure Electromagnetic Emissions from Electric Satellite Thrusters*, AIAA-2001-3344, 37th AIAA/ASME/SAE/ASEE Joint Propulsion Conference & Exhibit, Salt Lake City, Utah, 8–11 July 2001.

Appendix I: Log of Electromagnetic Data

No.	Disch V	A Flow R	C Flow R	EM	File ID	Time	Date
<i>CALIBRATE INSTRUMENT</i>							
<i>ACTIVE ROD (10kHz - 30MHz)</i>							
1	OFF	OFF	OFF	1	TS EM-1-OOFF	11:27	6/12/2001
2	225	0.8	0.064	1	TS EM-1-A225	13:18	6/12/2001
3	250	0.8	0.064	1	TS EM-1-A250	13:25	6/12/2001
4	275	0.8	0.064	1	TS EM-1-A275	13:29	6/12/2001
5	300	0.8	0.064	1	TS EM-1-A300	13:34	6/12/2001
6	225	0.9	0.072	1	TS EM-1-B225	13:52	6/12/2001
7	250	0.9	0.072	1	TS EM-1-B250	13:57	6/12/2001
8	275	0.9	0.072	1	TS EM-1-B275	14:04	6/12/2001
9	300	0.9	0.072	1	TS EM-1-B300	14:11	6/12/2001
10	225	0.94	0.074	1	TS EM-1-C225	12:35	6/12/2001
11	250	0.94	0.074	1	TS EM-1-C250	12:17	6/12/2001
12	275	0.94	0.074	1	TS EM-1-C275	12:44	6/12/2001
13	300	0.94	0.074	1	TS EM-1-C300	12:55	6/12/2001
14	225	1.0	0.080	1	TS EM-1-D225	14:40	6/12/2001
15	250	1.0	0.080	1	TS EM-1-D250	14:45	6/12/2001
16	275	1.0	0.080	1	TS EM-1-D275	14:52	6/12/2001
17	300	1.0	0.080	1	TS EM-1-D300	NOT DONE	6/12/2001
<i>CHANGE TO BICONNICAL (30 MHz - 200 MHz, Horizontal Polarization), CHANGE CABLE</i>							
18	225	0.8	0.064	2	TS EM-2-A225	15:38	6/12/2001
19	250	0.8	0.064	2	TS EM-2-A250	15:43	6/12/2001
20	275	0.8	0.064	2	TS EM-2-A275	15:48	6/12/2001
21	300	0.8	0.064	2	TS EM-2-A300	15:55	6/12/2001
22	225	0.9	0.072	2	TS EM-2-B225	16:08	6/12/2001
23	250	0.9	0.072	2	TS EM-2-B250	16:12	6/12/2001
24	275	0.9	0.072	2	TS EM-2-B275	16:15	6/12/2001
25	300	0.9	0.072	2	TS EM-2-B300	16:20	6/12/2001
26	225	0.94	0.074	2	TS EM-2-C225	16:35	6/12/2001
27	250	0.94	0.074	2	TS EM-2-C250	16:39	6/12/2001
28	275	0.94	0.074	2	TS EM-2-C275	16:41	6/12/2001
29	300	0.94	0.074	2	TS EM-2-C300	16:45	6/12/2001
30	225	1.0	0.080	2	TS EM-2-D225	15:06	6/12/2001
31	250	1.0	0.080	2	TS EM-2-D250	15:14	6/12/2001
32	275	1.0	0.080	2	TS EM-2-D275	15:19	6/12/2001
33	300	1.0	0.080	2	TS EM-2-D300	NOT DONE	6/12/2001
34	OFF	OFF	OFF	2	TS EM-2-OOFF	16:56	6/12/2001
<i>ROTATE BICONNICAL TO VERTICAL POLARIZATION</i>							
35	OFF	OFF	OFF	3	TS EM-3-OOFF	17:00	6/12/2001
36	225	0.8	0.064	3	TS EM-3-A225	17:34	6/12/2001
37	250	0.8	0.064	3	TS EM-3-A250	17:38	6/12/2001
38	275	0.8	0.064	3	TS EM-3-A275	17:41	6/12/2001
39	300	0.8	0.064	3	TS EM-3-A300	17:46	6/12/2001
40	225	0.9	0.072	3	TS EM-3-B225	17:57	6/12/2001
41	250	0.9	0.072	3	TS EM-3-B250	18:01	6/12/2001
42	275	0.9	0.072	3	TS EM-3-B275	18:04	6/12/2001
43	300	0.9	0.072	3	TS EM-3-B300	18:08	6/12/2001
44	225	0.94	0.074	3	TS EM-3-C225	17:12	6/12/2001
45	250	0.94	0.074	3	TS EM-3-C250	17:16	6/12/2001
46	275	0.94	0.074	3	TS EM-3-C275	17:18	6/12/2001
47	300	0.94	0.074	3	TS EM-3-C300	17:21	6/12/2001
48	225	1.0	0.080	3	TS EM-3-D225	18:19	6/12/2001
49	250	1.0	0.080	3	TS EM-3-D250	18:22	6/12/2001
50	275	1.0	0.080	3	TS EM-3-D275	18:26	6/12/2001
51	300	1.0	0.080	3	TS EM-3-D300	NOT DONE	6/12/2001

No.	Disch V	A Flow R	C Flow R	EM	File ID	Time	Date
<i>CHANGE TO DR HORN 1 (200 MHz - 1000 MHz, Horizontal Polarization), RECALIBRATE</i>							
52	225	0.8	0.064	4	TS EM-4-A225	8:27	6/13/2001
53	250	0.8	0.064	4	TS EM-4-A250	8:24	6/13/2001
54	275	0.8	0.064	4	TS EM-4-A275	8:38	6/13/2001
55	300	0.8	0.064	4	TS EM-4-A300	8:43	6/13/2001
56	225	0.9	0.072	4	TS EM-4-B225	8:58	6/13/2001
57	250	0.9	0.072	4	TS EM-4-B250	9:04	6/13/2001
58	275	0.9	0.072	4	TS EM-4-B275	9:10	6/13/2001
59	300	0.9	0.072	4	TS EM-4-B300	9:16	6/13/2001
60	225	0.94	0.074	4	TS EM-4-C225	9:29	6/13/2001
61	250	0.94	0.074	4	TS EM-4-C250	9:33	6/13/2001
62	275	0.94	0.074	4	TS EM-4-C275	9:39	6/13/2001
63	300	0.94	0.074	4	TS EM-4-C300	9:43	6/13/2001
64	225	1.0	0.080	4	TS EM-4-D225	8:00	6/13/2001
65	250	1.0	0.080	4	TS EM-4-D250	8:08	6/13/2001
66	275	1.0	0.080	4	TS EM-4-D275	8:15	6/13/2001
67	300	1.0	0.080	4	TS EM-4-D300	NOT DONE	6/13/2001
68	OFF	OFF	OFF	4	TS EM-4-OOFF	7:24	6/13/2001
<i>ROTATE DR HORN 1 TO VERTICAL POLARIZATION</i>							
69	OFF	OFF	OFF	5	TS EM-5-OOFF	11:46	6/13/2001
70	225	0.8	0.064	5	TS EM-5-A225	10:25	6/13/2001
71	250	0.8	0.064	5	TS EM-5-A250	10:30	6/13/2001
72	275	0.8	0.064	5	TS EM-5-A275	10:35	6/13/2001
73	300	0.8	0.064	5	TS EM-5-A300	10:43	6/13/2001
74	225	0.9	0.072	5	TS EM-5-B225	10:55	6/13/2001
75	250	0.9	0.072	5	TS EM-5-B250	11:00	6/13/2001
76	275	0.9	0.072	5	TS EM-5-B275	11:04	6/13/2001
77	300	0.9	0.072	5	TS EM-5-B300	11:11	6/13/2001
78	225	0.94	0.074	5	TS EM-5-C225	10:01	6/13/2001
79	250	0.94	0.074	5	TS EM-5-C250	10:05	6/13/2001
80	275	0.94	0.074	5	TS EM-5-C275	10:09	6/13/2001
81	300	0.94	0.074	5	TS EM-5-C300	10:13	6/13/2001
82	225	1.0	0.080	5	TS EM-5-D225	11:22	6/13/2001
83	250	1.0	0.080	5	TS EM-5-D250	11:22	6/13/2001
84	275	1.0	0.080	5	TS EM-5-D275	11:28	6/13/2001
85	300	1.0	0.080	5	TS EM-5-D300	11:35	6/13/2001
<i>CHANGE TO DR HORN 2 (1 GHz - 2 GHz, Horizontal Polarization), RECALIBRATE</i>							
86	225	0.8	0.064	6	TS EM-6-A225	12:56	6/13/2001
87	250	0.8	0.064	6	TS EM-6-A250	12:59	6/13/2001
88	275	0.8	0.064	6	TS EM-6-A275	13:01	6/13/2001
89	300	0.8	0.064	6	TS EM-6-A300	13:06	6/13/2001
90	225	0.9	0.072	6	TS EM-6-B225	14:01	6/13/2001
91	250	0.9	0.072	6	TS EM-6-B250	13:58	6/13/2001
92	275	0.9	0.072	6	TS EM-6-B275	13:55	6/13/2001
93	300	0.9	0.072	6	TS EM-6-B300	13:52	6/13/2001
94	225	0.94	0.074	6	TS EM-6-C225	14:13	6/13/2001
95	250	0.94	0.074	6	TS EM-6-C250	14:17	6/13/2001
96	275	0.94	0.074	6	TS EM-6-C275	14:21	6/13/2001
97	300	0.94	0.074	6	TS EM-6-C300	14:25	6/13/2001
98	225	1.0	0.080	6	TS EM-6-D225	12:41	6/13/2001
99	250	1.0	0.080	6	TS EM-6-D250	12:37	6/13/2001
100	275	1.0	0.080	6	TS EM-6-D275	12:34	6/13/2001
101	300	1.0	0.080	6	TS EM-6-D300	NOT DONE	6/13/2001
102	OFF	OFF	OFF	6	TS EM-6-OOFF	11:56	6/13/2001

No.	Disch V	A Flow R	C Flow R	EM	File ID	Time	Date
<i>ROTATE DR HORN 2 TO VERTICAL POLARIZATION</i>							
103	OFF	OFF	OFF	7	TS EM-7-OOFF	12:00	6/13/2001
104	225	0.8	0.064	7	TS EM-7-A225	13:22	6/13/2001
105	250	0.8	0.064	7	TS EM-7-A250	13:17	6/13/2001
106	275	0.8	0.064	7	TS EM-7-A275	13:15	6/13/2001
107	300	0.8	0.064	7	TS EM-7-A300	13:08	6/13/2001
108	225	0.9	0.072	7	TS EM-7-B225	13:36	6/13/2001
109	250	0.9	0.072	7	TS EM-7-B250	13:38	6/13/2001
110	275	0.9	0.072	7	TS EM-7-B275	13:41	6/13/2001
111	300	0.9	0.072	7	TS EM-7-B300	13:47	6/13/2001
112	225	0.94	0.074	7	TS EM-7-C225	14:39	6/13/2001
113	250	0.94	0.074	7	TS EM-7-C250	14:35	6/13/2001
114	275	0.94	0.074	7	TS EM-7-C275	14:31	6/13/2001
115	300	0.94	0.074	7	TS EM-7-C300	14:28	6/13/2001
116	225	1.0	0.080	7	TS EM-7-D225	12:23	6/13/2001
117	250	1.0	0.080	7	TS EM-7-D250	12:28	6/13/2001
118	275	1.0	0.080	7	TS EM-7-D275	12:38	6/13/2001
119	300	1.0	0.080	7	TS EM-7-D300	NOT DONE	6/13/2001
<i>ROTATE DR HORN 2 TO HORIZONTAL POLARIZATION (2 GHz - 18 GHz)</i>							
120	225	0.8	0.064	8	TS EM-8-A225	7:43	6/14/2001
121	250	0.8	0.064	8	TS EM-8-A250	8:04	6/14/2001
122	275	0.8	0.064	8	TS EM-8-A275	8:11	6/14/2001
123	300	0.8	0.064	8	TS EM-8-A300	8:34	6/14/2001
124	225	0.9	0.072	8	TS EM-8-B225	8:44	6/14/2001
125	250	0.9	0.072	8	TS EM-8-B250	9:06	6/14/2001
126	275	0.9	0.072	8	TS EM-8-B275	9:12	6/14/2001
127	300	0.9	0.072	8	TS EM-8-B300	9:34	6/14/2001
128	225	0.94	0.074	8	TS EM-8-C225	6:36	6/14/2001
129	250	0.94	0.074	8	TS EM-8-C250	7:01	6/14/2001
130	275	0.94	0.074	8	TS EM-8-C275	7:08	6/14/2001
131	300	0.94	0.074	8	TS EM-8-C300	7:31	6/14/2001
132	225	1.0	0.080	8	TS EM-8-D225	11:34	6/14/2001
133	250	1.0	0.080	8	TS EM-8-D250	11:41	6/14/2001
134	275	1.0	0.080	8	TS EM-8-D275	12:02	6/14/2001
135	300	1.0	0.080	8	TS EM-8-D300	NOT DONE	6/14/2001
136	OFF	OFF	OFF	8	TS EM-8-OOFF	9:40	6/14/2001
<i>ROTATE DR HORN 2 TO VERTICAL POLARIZATION</i>							
137	OFF	OFF	OFF	9	TS EM-9-OOFF	9:46	6/14/2001
138	225	0.8	0.064	9	TS EM-9-A225	7:50	6/14/2001
139	250	0.8	0.064	9	TS EM-9-A250	7:57	6/14/2001
140	275	0.8	0.064	9	TS EM-9-A275	8:18	6/14/2001
141	300	0.8	0.064	9	TS EM-9-A300	8:27	6/14/2001
142	225	0.9	0.072	9	TS EM-9-B225	8:51	6/14/2001
143	250	0.9	0.072	9	TS EM-9-B250	8:59	6/14/2001
144	275	0.9	0.072	9	TS EM-9-B275	9:19	6/14/2001
145	300	0.9	0.072	9	TS EM-9-B300	9:27	6/14/2001
146	225	0.94	0.074	9	TS EM-9-C225	6:47	6/14/2001
147	250	0.94	0.074	9	TS EM-9-C250	6:54	6/14/2001
148	275	0.94	0.074	9	TS EM-9-C275	7:16	6/14/2001
149	300	0.94	0.074	9	TS EM-9-C300	7:24	6/14/2001
150	225	1.0	0.080	9	TS EM-9-D225	11:28	6/14/2001
151	250	1.0	0.080	9	TS EM-9-D250	11:48	6/14/2001
152	275	1.0	0.080	9	TS EM-9-D275	11:55	6/14/2001
153	300	1.0	0.080	9	TS EM-9-D300	NOT DONE	6/14/2001

No.	Disch V	A Flow R	C Flow R	EM	File ID	Time	Date	Notes
<i>ACTIVE ROD (10kHz - 30MHz)</i>								
154	250	0.94	0.075	1	TS EM-1-C250-8	12:59	6/14/2001	10 dB ant attn + 20 dB attn preSel
155	250	0.94	0.0564	1	TS EM-1-C250-6	13:14	6/14/2001	
156	250	0.94	0.0376	1	TS EM-1-C250-4		6/14/2001	thruster would not run
157	250	0.94	0.094	1	TS EM-1-C250-10	13:31	6/14/2001	
158	250	0.94	0.1128	1	TS EM-1-C250-12	13:37	6/14/2001	
159	OFF	OFF	OFF	1	TS EM-1-C250-OFF	13:39	6/14/2001	

MEASUREMENTS WITH FILTER OUTSIDE OF THE CHAMBER								
No.	Disch V	A Flow R	C Flow R	EM	File ID	Time	Date	Tek File
<i>CALIBRATE INSTRUMENT</i>								
<i>ACTIVE ROD with 10 dB internal attenuation (10kHz - 30MHz)</i>								Video Filter OFF/ON
162	OFF	OFF	OFF	1a	TS EM-1a-OFF-o	10:29	6/18/2001	
163	250	0.94	0.074	1a	TS EM-1a-C250-8-o	11:30	6/18/2001	B753F884/B753F8E9
164	250	0.94	0.074	1a	TS EM-1a-C250-6-o	11:37	6/18/2001	B753FB20/B753FB5F
165	250	0.94	0.074	1a	TS EM-1a-C250-10-o	11:47	6/18/2001	B753FD16/B753FD57
166	250	0.94	0.074	1a	TS EM-1a-C250-12-o	11:53	6/18/2001	B753FFOC/B753FF56
<i>ACTIVE ROD (10kHz - 30MHz)</i>								
167	250	0.94	0.074	1	TS EM-1-C250-8-o	12:20	6/18/2001	
168	250	0.94	0.074	1	TS EM-1-C250-6-o	12:26	6/18/2001	
169	250	0.94	0.074	1	TS EM-1-C250-10-o	12:12	6/18/2001	
170	250	0.94	0.074	1	TS EM-1-C250-12-o	12:06	6/18/2001	
171	OFF	OFF	OFF	1	TS EM-1-OFF-o	12:30	6/18/2001	B75407F8/B7540838
<i>CHANGE TO BICONNICAL (30 MHz - 200 MHz, Horizontal Polarization), CHANGE CABLE</i>								
172	OFF	OFF	OFF	2	TS EM-2-OFF-o	12:42	6/18/2001	
173	250	0.94	0.074	2	TS EM-2-C250-8-o	13:02	6/18/2001	B7540F1F/B7540F62
<i>ROTATE BICONNICAL TO VERTICAL POLARIZATION</i>								
174	250	0.94	0.074	3	TS EM-3-C250-8-o	13:07	6/18/2001	
175	OFF	OFF	OFF	3	TS EM-3-OFF-o	13:11	6/18/2001	B75410C0/B7541101
<i>CHANGE TO DR HORN 1 (200 MHz - 1000 MHz, Horizontal Polarization),</i>								
176	OFF	OFF	OFF	4	TS EM-4-OFF-o	13:22	6/18/2001	
177	250	0.94	0.074	4	TS EM-4-C250-8-o	13:45	6/18/2001	
<i>ROTATE DR HORN 1 TO VERTICAL POLARIZATION</i>								
178	250	0.94	0.074	5	TS EM-5-C250-8-o	13:59	6/18/2001	
179	OFF	OFF	OFF	5	TS EM-5-OFF-o	14:04	6/18/2001	
<i>CHANGE TO DR HORN 2 (1 GHz - 2 GHz, Horizontal Polarization),</i>								
180	OFF	OFF	OFF	6	TS EM-6-OFF-o	14:15	6/18/2001	
181	250	0.94	0.074	6	TS EM-6-C250-8-o	14:36	6/18/2001	
<i>ROTATE DR HORN 2 TO VERTICAL POLARIZATION</i>								
182	250	0.94	0.074	7	TS EM-7-C250-8-o	14:42	6/18/2001	
183	OFF	OFF	OFF	7	TS EM-7-OFF-o	14:45	6/18/2001	
<i>ROTATE DR HORN 2 TO HORIZONTAL POLARIZATION (2 GHz - 18 GHz)</i>								
184	OFF	OFF	OFF	8	TS EM-8-OFF-o	14:49	6/18/2001	
185	250	0.94	0.074	8	TS EM-8-C250-8-o	15:20	6/18/2001	
<i>ROTATE DR HORN 2 TO VERTICAL POLARIZATION</i>								
186	250	0.94	0.075	9	TS EM-9-C250-8-o	15:27	6/18/2001	
187	OFF	OFF	OFF	9	TS EM-9-OFF-o	15:33	6/18/2001	

Appendix II: Operating Points

Date	Run	Time	V Dot An	M Dot An	V Dot Cath	M Dot Cath	Tank Press.	V Keepr	J Keepr	Keepr Pwr	V Dschrg	J Dschrg	Dschrg Pwr	V Mag	J Mag	Mag Pwr	Floating V
37054		0.430555556	7.7	0.8	0.8	0.083	0.00000597	12.4	0.49	6.076	250	0.8	200	3.69	1	3.69	-7.61
37054		0.451388889	7.7	0.8	0.8	0.083	0.00000597	12.5	0.49	6.125	250	0.8	200	4.01	1	4.01	-7.65
37054		0.464583333	7.7	0.8	0.8	0.083	0.00000602	12.4	0.49	6.076	275	0.81	222.75	4.16	1.01	4.2016	-7.5
37054		0.466666667	7.7	0.8	0.8	0.083	0.00000597	12.5	0.49	6.125	226	0.8	180.8	4.13	1	4.13	-7.65
37054		0.472916667	7.7	0.8	0.64	0.066	0.00000587	12.5	0.49	6.125	226	0.8	180.8	4.14	1	4.14	-7.62
37054	No. 11	0.520833333	7.7	0.8	0.72	0.074	0.00000583	12.5	0.49	6.125	225	0.8	180	3.96	1	3.96	-7.63
37054	No. 10	0.525	7.7	0.8	0.72	0.074	0.00000581	12.5	0.49	6.125	225	0.8	180	3.96	1	3.96	-7.63
37054	No. 12	0.527777778	7.7	0.8	0.72	0.074	0.00000586	12.5	0.49	6.125	275	0.81	222.75	4.01	1	4.01	-7.64
37054	No. 12A	0.534027778	7.7	0.8	0.72	0.074	0.00000592	12.5	0.49	6.125	220	0.8	220	5.12	1.41	7.2192	-7.64
37054	No. 13	0.534722222	7.7	0.8	0.72	0.074	0.00000597	12.5	0.49	6.125	300	0.84	252	4.13	1	4.13	-7.68
37054	No. 2	0.555555556	6.6	0.68	0.64	0.065	0.00000509	13.2	0.49	6.468	225	0.67	150.75	2.38	0.66	1.5708	-8.29
37054	No. 3	0.559027778	6.6	0.68	0.64	0.065	0.00000512	13.3	0.49	6.517	250	0.67	167.5	2.82	0.7	1.974	-8.5
37054	No. 4	0.5625	6.6	0.68	0.64	0.065	0.00000517	13.3	0.49	6.517	275	0.67	184.25	2.82	0.7	1.974	-8.62
37054	No. 5		6.6	0.68	0.64	0.065	0.0000052	13.3	0.49	6.517	300	0.67	201	2.62	0.65	1.703	-8.7
37054	No. 6	0.577083333	7.4	0.77	0.7	0.72	0.00000556	12.7	0.49	6.223	225	0.77	173.25	3.26	0.8	2.608	-7.72
37054	No. 7	0.58125	7.4	0.77	0.7	0.72	0.00000556	12.7	0.49	6.223	250	0.76	190	3.66	0.9	3.294	-7.83
37054	No. 8	0.586111111	7.4	0.77	0.7	0.72	0.00000564	12.7	0.49	6.223	275	0.76	209	3.7	0.9	3.33	-7.83
37054	No. 9	0.590972222	7.4	0.77	0.7	0.72	0.00000572	12.8	0.49	6.272	300	0.77	231	2.87	0.72	2.0664	-7.98
37054	No. 11B	14.23	7.8	0.81	0.72	0.074	0.00000591	12.5	0.49	6.125	250	0.81	202.5	4.03	0.99	3.9897	-7.62
37054	No. 14	0.611111111	8.3	0.86	0.78	0.08	0.00000614	11.4	0.49	5.886	225	0.86	193.5	5.07	1.2	6.084	-6.69
37054	No. 15	0.614583333	8.2	0.86	0.78	0.08	0.0000062	11.4	0.49	5.886	250	0.87	217.5	5.1	1.2	6.12	-6.71
37054	No. 16	0.619444444	8.2	0.86	0.78	0.08	0.00000623	11.4	0.49	5.886	275	0.87	239.25	6.42	1.49	9.5658	-6.57
37054	No. 30	0.631944444	8.2	0.86	0.77	0.08	0.00000614	11.4	0.49	5.886	225	0.86	193.5	5.23	1.2	6.276	-6.69
37054	No. 31	0.635416667	8.2	0.86	0.77	0.08	0.00000619	11.4	0.49	5.886	250	0.87	217.5	5.24	1.2	6.288	-6.71
37054	No. 32	0.639583333	8.2	0.86	0.77	0.08	0.00000622	11.4	0.49	5.886	275	0.85	233.75	6.55	1.49	9.7595	-6.62
37054	No. 18	0.649305556	6.6	0.68	0.64	0.066	0.00000511	12.3	0.49	6.027	225	0.67	150.75	3.08	0.7	2.156	-7.44
37054	No. 19	0.654661111	6.6	0.68	0.64	0.066	0.00000512	12.4	0.49	6.076	250	0.67	167.5	3.01	0.7	2.107	-7.71
37054	No. 20	0.661805556	6.6	0.68	0.64	0.066	0.00000515	12.5	0.49	6.125	275	0.67	184.25	2.99	0.7	2.093	-7.89
37054	No. 21	0.663194444	6.6	0.68	0.64	0.066	0.00000518	12.6	0.49	6.174	300	0.68	204	2.68	0.63	1.6884	-8.03
37054	No. 25	0.68125	7.4	0.77	0.7	0.72	0.00000563	12.1	0.49	6.125	225	0.67	150.75	2.77	0.66	1.8282	-7.59
37054	No. 22	0.673611111	7.4	0.77	0.7	0.72	0.00000553	12.4	0.49	6.076	225	0.77	173.25	3.31	0.7	2.317	-7.13
37054	No. 23	0.675694444	7.4	0.77	0.7	0.72	0.00000558	12.1	0.49	5.929	250	0.76	190	3.72	0.9	3.348	-7.29
37054	No. 24	0.677083333	7.4	0.77	0.7	0.72	0.00000563	12.1	0.49	5.929	275	0.77	211.75	3.74	0.9	3.366	-7.37
37054	No. 26	0.691666667	7.8	0.81	0.72	0.74	0.00000581	11.9	0.49	5.831	300	0.77	231	3.01	0.72	2.1672	-7.49
37054	No. 27	0.694444444	7.8	0.81	0.72	0.74	0.00000585	11.9	0.49	5.831	225	0.81	182.25	4.2	1	4.2	-7.04
37054	No. 28	0.696527778	7.8	0.81	0.72	0.74	0.00000588	11.9	0.49	5.831	250	0.81	202.5	4.21	1	4.21	-7.16
37054	No. 29	0.697916667	7.8	0.81	0.72	0.74	0.00000592	11.9	0.49	5.831	275	0.82	225.5	4.21	1	4.21	-7.12
37054		0.704861111			0.72	0.74	0.00000592	11.9	0.49	5.831	300	0.82	246	4.24	1	4.24	-7.1
37054	No. 44	0.717361111	7.8	0.81	0.72	0.74	0.00000572	11.9	0.49	5.831	225	0.81	182.25	4.09	1	4.09	-6.97
37054	No. 45	0.719444444	7.8	0.81	0.72	0.74	0.00000579	11.9	0.49	5.831	250	0.81	202.5	4.1	1	4.1	-7.01
37054	No. 46	0.721527778	7.8	0.81	0.72	0.74	0.00000583	11.9	0.49	5.831	275	0.82	225.5	4.12	1	4.12	-6.99
37054		0.722916667	7.8	0.81	0.72	0.74	0.00000587	11.8	0.49	5.782	300	0.82	246	4.12	1	4.12	-6.98
37054	No. 36	0.732638889	6.6	0.68	0.63	0.065	0.00000506	12.4	0.49	6.076	225	0.67	150.75	2.93	0.7	2.051	-7.52
37054	No. 37	0.734722222	6.6	0.68	0.63	0.065	0.0000051	12.5	0.49	6.125	250	0.67	167.5	2.83	0.7	2.051	-7.52
37054	No. 38	0.7375	6.6	0.68	0.63	0.065	0.0000051	12.5	0.49	6.125	275	0.67	184.25	2.89	0.7	2.023	-7.97

Date	Run	Time	V Dot An	M Dot An	V Dot Cath	M Dot Cath	Tank Press.	V Keepr	J Keepr	Keepr Pwr	V Dschrg	J Dschrg	Dschrg Pwr	V Mag	J Mag	Mag Pwr	Floating V
37054	No. 39	0.740972222	6.6	0.68	0.63	0.065	0.00000514	12.6	0.49	6.174	300	0.86	204	2.64	0.63	1.6632	-8.07
37054	No. 40	0.747916667	7.7	0.77	0.7	0.72	0.00000553	12.1	0.49	5.929	225	0.77	173.25	2.89	0.7	2.023	-7.18
37054	No. 41	0.751388889	7.7	0.77	0.7	0.72	0.00000556	12.1	0.49	5.929	250	0.76	190	3.66	0.9	3.294	-7.35
37054	No. 42	0.753472222	7.7	0.77	0.7	0.72	0.00000561	12.22	0.49	5.9878	275	0.77	211.75	3.67	0.9	3.303	-7.47
37054	No. 43	0.75625	7.7	0.77	0.7	0.72	0.00000564	12.2	0.49	5.978	300	0.77	231	2.98	0.72	2.1456	-7.6
37054	No. 48	0.763888889	8.2	0.86	0.78	0.8	0.00000608	11.7	0.49	5.733	225	0.86	193.5	4.88	1.19	5.8072	-6.97
37054	No. 49	0.765972222	8.2	0.86	0.78	0.8	0.00000612	11.7	0.49	5.733	250	0.86	215	5.01	1.2	6.012	-7.03
37054	No. 50	0.768055556	8.2	0.86	0.78	0.8	0.00000615	11.7	0.49	5.733	275	0.86	236.5	6.22	1.49	9.2678	-7.04
37055	No. 64	0.324305556	8.2	0.86	0.78	0.08	0.00000585	11.5	0.5	5.75	225	0.86	193.5	3.23	1	3.23	-6.79
37055	No. 64	0.333333333	8.2	0.86	0.78	0.08	0.00000587	11.5	0.5	5.75	225	0.86	193.5	4.13	1.2	4.956	-6.83
37055	No. 65	0.338194444	8.2	0.86	0.78	0.08	0.0000059	11.5	0.5	5.75	250	0.86	215	4.31	1.2	5.172	-6.9
37055	No. 66	0.34375	8.2	0.86	0.78	0.08	0.00000593	11.6	0.5	5.8	275	0.86	236.5	5.59	1.49	8.3291	-6.89
37055	No. 52	0.352083333	6.6	0.68	0.64	0.065	0.00000492	12.4	0.5	6.2	225	0.66	148.5	2.82	0.7	1.974	-7.47
37055	No. 53	0.356944444	6.6	0.68	0.64	0.065	0.00000492	12.5	0.5	6.25	250	0.66	165	2.83	0.7	1.981	-7.7
37055	No. 54	0.360416667	6.6	0.68	0.64	0.065	0.00000493	12.5	0.5	6.25	275	0.67	184.25	2.83	0.7	1.981	-7.89
37055	No. 55	0.363888889	6.6	0.68	0.64	0.065	0.00000494	12.5	0.5	6.25	300	0.67	201	2.57	0.63	1.6191	-8.02
37055	No. 56	0.373611111	7.4	0.77	0.7	0.072	0.00000543	12.1	0.5	6.05	225	0.76	171	2.86	0.7	2.002	-7.15
37055	No. 57	0.378472222	7.4	0.77	0.7	0.072	0.00000549	12.1	0.5	6.05	250	0.76	190	3.62	0.9	3.258	-7.33
37055	No. 58	0.381944444	7.4	0.77	0.7	0.072	0.0000055	12.2	0.5	6.1	275	0.76	209	3.67	0.9	3.303	-7.45
37055	No. 59	0.386111111	7.4	0.77	0.7	0.072	0.00000549	12.1	0.5	6.05	300	0.77	231	2.95	0.72	2.124	-7.61
37055	No. 60	0.395833333	7.8	0.81	0.72	0.074	0.00000569	11.9	0.5	5.95	225	0.81	182.25	4.13	1	4.13	-7.13
37055	No. 61	0.398611111	7.8	0.81	0.72	0.074	0.00000574	12	0.5	6	250	0.81	202.5	4.15	1	4.15	-7.17
37055	No. 62	0.402777778	7.8	0.81	0.72	0.074	0.00000575	12	0.5	6	275	0.81	222.75	4.18	1	4.18	-7.14
37055	No. 63	0.405555556	7.8	0.81	0.72	0.074	0.00000576	12	0.5	6	300	0.81	243	4.21	1	4.21	-7.24
37055	No. 78	0.417361111	7.8	0.81	0.72	0.074	0.0000057	11.9	0.5	5.95	225	0.81	182.25	4.27	1	4.27	-7.05
37055	No. 79	0.420138889	7.8	0.81	0.72	0.074	0.00000574	12	0.5	6	250	0.81	202.5	4.28	1	4.28	-7.17
37055	No. 80	0.423611111	7.8	0.81	0.72	0.074	0.00000574	12	0.5	6	275	0.81	222.75	4.29	1	4.29	-7.24
37055	No. 81	0.426388889	7.8	0.81	0.72	0.074	0.00000577	12	0.5	6	300	0.81	243	4.29	1	4.29	-7.21
37055	No. 70	0.434722222	6.6	0.68	0.64	0.065	0.00000502	12.6	0.5	6.3	225	0.67	150.75	3.03	0.7	2.121	-7.53
37055	No. 71	0.4375	6.6	0.68	0.64	0.065	0.00000505	12.6	0.5	6.3	250	0.67	167.5	3.03	0.7	2.121	-7.76
37055	No. 72	0.441666667	6.6	0.68	0.64	0.065	0.00000502	12.6	0.5	6.3	275	0.67	184.25	2.99	0.7	2.093	-7.97
37055	No. 73	0.447222222	6.6	0.68	0.64	0.065	0.00000502	12.5	0.5	6.25	300	0.67	201	2.69	0.63	1.6947	-8.18
37055	No. 74	0.454861111	7.4	0.77	0.7	0.072	0.00000545	11.9	0.5	5.95	225	0.77	173.25	2.95	0.7	2.065	-7.35
37055	No. 75	0.458333333	7.4	0.77	0.7	0.072	0.00000551	11.9	0.5	5.95	250	0.77	192.5	3.74	0.9	3.366	-7.53
37055	No. 76	0.461805556	7.4	0.77	0.7	0.072	0.00000554	12	0.5	6	275	0.77	211.75	3.75	0.9	3.375	-7.66
37055	No. 77	0.465972222	7.4	0.77	0.7	0.072	0.00000553	12	0.5	6	300	0.77	231	3.06	0.72	2.2032	-7.77
37055	No. 82	0.473611111	8.2	0.86	0.78	0.08	0.000006	11.5	0.5	5.75	225	0.86	193.5	4.18	1	4.18	-7.11
37055	No. 83	0.477777778	8.2	0.86	0.78	0.08	0.00000605	11.5	0.5	5.75	250	0.86	215	5.02	1.2	6.024	-7.27
37055	No. 84	0.482638889	8.2	0.86	0.78	0.08	0.00000605	11.5	0.5	5.75	275	0.86	236.5	5.12	1.2	6.144	-7.12
37055	No. 85	0.488194444	8.2	0.86	0.78	0.08	0.00000605	11.5	0.5	5.75	300	0.87	261	6.37	1.49	9.4913	-7.12
37055	No. 116	0.516666667	8.2	0.86	0.78	0.08	0.00000591	11.5	0.5	5.75	225	0.86	193.5	3.96	1	3.96	-6.85
37055	No. 117	0.520138889	8.2	0.86	0.78	0.08	0.00000597	11.6	0.5	5.8	250	0.86	215	4.77	1.2	5.724	-6.95
37055	No. 118	0.521527778	8.2	0.86	0.78	0.08	0.00000598	11.5	0.5	5.75	275	0.86	236.5	4.81	1.2	5.772	-6.81
37055	No. 119	0.525277778	8.2	0.86	0.78	0.08	0.00000598	11.5	0.5	5.75	300	0.86	261	6.37	1.49	9.4913	-7.12

Date	Run	Time	V Dot An	M Dot An	V Dot Cath	M Dot Cath	Tank Press.	V Kepr	J Kepr	Kepr Pwr	V Dschrg	J Dschrg	Dschrg Pwr	V Mag	J Mag	Mag Pwr	Floating V
37055	No. 98	0.529166667	8.2	0.86	0.78	0.08	0.00000595	11.5	0.5	5.75	225	0.86	193.5	4.22	1	4.22	-6.79
37055	No. 99	0.519444444	8.2	0.86	0.78	0.08	0.00000595	11.6	0.5	5.8	250	0.86	215	4.22	1.2	5.904	-6.92
37055	No. 100	0.524305556	8.2	0.86	0.78	0.08	0.00000597	11.5	0.5	5.75	275	0.86	236.5	4.87	1.2	5.844	-6.87
37055			8.2	0.86	0.78	0.08		0	0.5	0			0		1.49	0	
37055	No. 86	0.539583333	6.6	0.68	0.64	0.065	0.00000493	12.4	0.5	6.2	225	0.67	150.75	2.99	0.7	2.093	-7.53
37055	No. 87	0.540972222	6.6	0.68	0.64	0.065	0.00000497	12.4	0.5	6.2	250	0.67	167.5	2.98	0.7	2.086	-7.74
37055	No. 88	0.543055556	6.6	0.68	0.64	0.065	0.00000489	12.5	0.5	6.25	275	0.67	184.25	2.97	0.7	2.079	-7.9
37055	No. 89	0.545833333	6.6	0.68	0.64	0.065	0.00000498	12.5	0.5	6.25	300	0.67	201	2.68	0.63	1.6684	-8.03
37055	No. 107	0.548611111	6.6	0.68	0.64	0.065	0.00000498	12.5	0.5	6.25	300	0.67	201	2.67	0.63	1.6821	-8.01
37055	No. 106	0.552083333	6.6	0.68	0.64	0.065	0.00000498	12.5	0.5	6.25	275	0.67	184.25	2.94	0.7	2.058	-7.92
37055	No. 105	0.553472222	6.6	0.68	0.64	0.065	0.00000494	12.5	0.5	6.25	250	0.67	167.5	2.93	0.7	2.051	-7.73
37055	No. 104	0.556944444	6.6	0.68	0.64	0.065	0.00000493	12.5	0.5	6.25	225	0.67	150.75	2.93	0.7	2.051	-7.53
37055	No. 108	0.565972222	7.4	0.77	0.7	0.072	0.00000542	12.1	0.5	6.05	225	0.77	173.25	2.94	0.7	2.058	-7.14
37055	No. 109	0.56875	7.4	0.77	0.7	0.072	0.00000546	12.1	0.5	6.05	250	0.76	190	3.73	0.9	3.357	-7.3
37055	No. 110	0.570138889	7.4	0.77	0.7	0.072	0.00000548	12.1	0.5	6.05	275	0.76	209	3.74	0.9	3.366	-7.42
37055	No. 111	0.571527778	7.4	0.77	0.7	0.072	0.00000549	12.1	0.5	6.05	300	0.77	231	3.42	0.82	2.8044	-7.49
37055	No. 93	0.578472222	7.4	0.77	0.7	0.072	0.0000055	12.1	0.5	6.05	300	0.77	231	3.42	0.82	2.8044	-7.42
37055	No. 92	0.580555556	7.4	0.77	0.7	0.072	0.00000572	12.2	0.5	6.1	275	0.76	209	3.75	0.9	3.375	-7.42
37055	No. 91	0.582638889	7.4	0.77	0.7	0.072	0.00000545	12.2	0.5	6.1	250	0.76	190	3.77	0.9	3.393	-7.32
37055	No. 90	0.584722222	7.4	0.77	0.7	0.072	0.00000545	12.1	0.5	6.05	225	0.77	173.25	2.98	0.7	2.086	-7.12
37055	No. 94	0.593055556	7.8	0.81	0.72	0.074	0.00000569	11.9	0.5	5.95	225	0.81	182.25	4.22	1	4.22	-7.03
37055	No. 95	0.595138889	7.8	0.81	0.72	0.074	0.00000572	11.9	0.5	5.95	250	0.81	202.5	4.25	1	4.25	-7.14
37055	No. 96	0.598611111	7.8	0.81	0.72	0.074	0.00000575	12	0.5	6	275	0.81	224.125	4.26	1	4.26	-7.17
37055	No. 97	0.601388889	7.8	0.81	0.72	0.074	0.00000575	11.9	0.5	5.95	300	0.82	246	5.08	1.2	6.096	-7.18
37055	No. 115	0.604166667	7.8	0.81	0.72	0.074	0.00000575	11.9	0.5	5.95	300	0.815	244.5	5.12	1.2	6.144	-7.17
37055	No. 114	0.605555556	7.8	0.81	0.72	0.074	0.00000573	12	0.5	6	275	0.81	222.75	4.32	1	4.32	-7.04
37055	No. 113	0.608333333	7.8	0.81	0.72	0.074	0.00000573	12	0.5	6	250	0.81	202.5	4.33	1	4.33	-7.16
37055	No. 112	0.569444444	7.8	0.81	0.72	0.074	0.00000573	11.9	0.5	5.95	225	0.81	182.25	4.33	1	4.33	-7.06
37056	No. 128	0.276388889	7.8	0.81	0.72	0.074	0.00000552	11.9	0.5	5.95	225	0.82	184.5	3.26	1	3.26	-7.17
37056	No. 146	0.283333333	7.8	0.81	0.72	0.074	0.00000553	11.9	0.5	5.95	225	0.82	184.5	3.5	1	3.5	-7.16
37056	No. 147	0.2875	7.8	0.81	0.72	0.074	0.00000556	11.9	0.5	5.95	250	0.82	205	3.6	1	3.6	-7.28
37056	No. 129	0.292361111	7.8	0.81	0.72	0.074	0.00000555	11.9	0.5	5.95	250	0.82	205	3.72	1	3.72	-7.27
37056	No. 130	0.296527778	7.8	0.81	0.72	0.074	0.00000559	11.9	0.5	5.95	275	0.82	225.5	3.8	1	3.8	-7.29
37056	No. 148	0.302777778	7.8	0.81	0.72	0.074	0.00000558	12	0.5	6	275	0.82	225.5	3.93	1	3.93	-7.28
37056	No. 149	0.308333333	7.8	0.81	0.72	0.074	0.00000561	11.9	0.5	5.95	300	0.82	246	4.82	1.2	5.784	-7.26
37056	No. 131	0.313194444	7.8	0.81	0.72	0.074	0.00000561	11.9	0.5	5.95	300	0.81	243	4.93	1.21	5.9653	-7.28
37056	No. 138	0.322222222	6.6	0.68	0.63	0.065	0.00000493	12.5	0.5	6.25	225	0.67	150.75	2.96	0.7	2.072	-7.6
37056	No. 139	0.327083333	6.6	0.68	0.63	0.065	0.00000491	12.6	0.5	6.3	225	0.67	150.75	2.94	0.7	2.058	-7.65
37056	No. 137	0.33125	6.6	0.68	0.63	0.065	0.00000493	12.7	0.5	6.35	250	0.67	167.5	2.9	0.7	2.03	-7.85
37056	No. 121	0.336111111	6.6	0.68	0.63	0.065	0.00000489	12.7	0.5	6.35	250	0.67	167.5	2.9	0.7	2.03	-7.84
37056	No. 122	0.340972222	6.6	0.68	0.63	0.065	0.00000491	12.7	0.5	6.35	275	0.67	184.25	2.88	0.7	2.016	-8.05
37056	No. 140	0.347222222	6.6	0.68	0.63	0.065	0.0000049	12.7	0.5	6.35	275	0.67	184.25	2.86	0.7	2.002	-8.05
37056	No. 141	0.352083333	6.6	0.68	0.63	0.065	0.00000494	12.7	0.5	6.35	300	0.675	202.5	2.98	0.63	1.6254	-8.14
37056	No. 123	0.356944444	6.6	0.68	0.63	0.065	0.00000491	12.7	0.5	6.35	300	0.675	202.5	2.98	0.62	1.5872	-8.13
37056	No. 124	0.363888889	7.4	0.77	0.7	0.072	0.00000533	12.3	0.5	6.15	225	0.77	173.25	2.85	0.7	1.995	-7.29
37056	No. 142	0.371527778	7.4	0.77	0.7	0.072	0.00000538	12.3	0.5	6.15	225	0.77	173.25	2.85	0.7	1.995	-7.29
37056	No. 143	0.374305556	7.4	0.77	0.7	0.072	0.0000054	12.3	0.5	6.15	250	0.76	190	3.63	0.9	3.267	-7.48
37056	No. 125	0.379861111	7.4	0.77	0.7	0.072	0.00000538	12.3	0.5	6.15	250	0.76	190	3.68	0.9	3.312	-7.49

Date	Run	Time	V Dot An	M Dot An	V Dot Cath	M Dot Cath	Tank Press.	V Keepr	J Keepr	Keepr Pwr	V Dschrg	J Dschrg	Dschrg Pwr	V Mag	J Mag	Mag Pwr	Floating V
37056	No. 126	0.363333333	7.4	0.77	0.7	0.072	0.0000543	12.3	0.5	6.15	275	0.76	209	3.68	0.9	3.312	-7.59
37056	No. 144	0.368888889	7.4	0.77	0.7	0.072	0.000054	12.3	0.5	6.15	275	0.76	209	3.68	0.9	3.312	-7.61
37056	No. 145	0.393055556	7.4	0.77	0.7	0.072	0.0000543	12.3	0.5	6.15	300	0.76	228	3.74	0.9	3.366	-7.65
37056	No. 127	0.397916667	7.4	0.77	0.7	0.072	0.0000545	11	0.5	5.5	300	0.8	240	3.62	0.86	3.1132	-7.24
37056	No. 136									0	0		0			0	
37056	No. 137									0	0		0			0	
37056	No. 150	0.478472222	8.3	0.86	0.77	0.08	0.0000584	11.8	0.5	5.9	225	0.87	195.75	3.49	1	3.49	-6.92
37056	No. 132	0.481944444	8.3	0.86	0.77	0.08	0.0000584	11.7	0.5	5.85	225	0.87	195.75	3.56	1	3.56	-6.91
37056	No. 133	0.486805556	8.3	0.86	0.77	0.08	0.0000588	11.7	0.5	5.85	250	0.87	217.5	4.29	1.2	5.148	-7.08
37056	No. 151	0.491666667	8.3	0.86	0.77	0.08	0.0000587	11.7	0.5	5.85	250	0.87	217.5	4.55	1.2	5.46	-7.05
37056	No. 152	0.496527778	8.3	0.86	0.77	0.08	0.000059	11.7	0.5	5.85	275	0.87	239.25	4.71	1.2	5.652	-7.07
37056	No. 134	0.501388889	8.3	0.86	0.77	0.08	0.0000589	11.7	0.5	5.85	275	0.87	239.25	4.84	1.2	5.808	-7.06
37056	No. 154	0.543055556	7.8	0.81	0.72	0.074	0.0000565	12	0.5	6	250	0.81	202.5	4.3	1	4.3	-7.19
37056	No. 155	0.551388889	7.8	0.81	0.56	0.057	0.0000561	12.1	0.5	6.05	250	0.81	202.5	4.3	1	4.3	-7.18
37056	No. 156									0	250		0			0	
37056	No. 157	0.5625	7.8	0.81	0.91	0.095	0.0000569	11.8	0.5	5.9	250	0.81	202.5	4.2	1	4.2	-7.32
37056	No. 158	0.566666667	7.8	0.81	1.09	0.113	0.0000577	11.7	0.5	5.85	250	0.81	202.5	4.22	1	4.22	-7.35
37056	No. 159	0.56875								0	0		0			0	
37056	No. 160	0.579166667	6.6	0.68	0.63	0.065	0.0000477	12.4	0.5	6.2	225	0.66	148.5	2.88	0.7	2.016	-7.52
37056	No. 161	0.584722222	6.6	0.68	0.63	0.065	0.000049	11.2	0.5	5.6	300	0.74	222	2.56	0.62	1.5872	-6.24
37060	No. 163	0.472222222	7.8	0.81	0.71	0.073	0.0000568	12.2	0.5	6.1	250	0.8	200	3.58	1	3.58	-7.7
37060	No. 164	0.483333333	7.8	0.81	0.56	0.058	0.0000571	12.3	0.5	6.15	250	0.8	200	3.95	1	3.95	-7.6
37060	No. 165	0.491666667	7.8	0.81	0.91	0.095	0.000058	12	0.5	6	250	0.8	200	4.05	1	4.05	-7.6
37060	No. 166	0.495138889	7.8	0.81	1.08	0.112	0.0000588	11.9	0.5	5.95	250	0.8	200	4.09	1	4.09	-7.6
37060	No. 170	0.503472222	7.8	0.81	1.08	0.112	0.0000588	11.9	0.5	5.95	250	0.8	200	4.09	1	4.09	-7.6
37060	No. 169	0.508333333	7.8	0.81	0.91	0.095	0.0000595	11.9	0.5	5.95	250	0.8	200	4.14	1	4.14	-7.6
37060	No. 167	0.513888889	7.8	0.81	0.72	0.074	0.0000584	12	0.5	6	250	0.8	200	4.18	1	4.18	-7.5
37060	No. 168	0.518055556	7.8	0.81	0.56	0.058	0.0000578	12.1	0.5	6.05	250	0.8	200	4.17	1	4.17	-7.5
37060	No. 171	0.520833333								0	0		0			0	
37060	No. 173	0.543055556	7.8	0.81	0.72	0.074	0.0000571	12.1	0.5	6.05	250	0.8	200	3.98	1	3.98	-7.4
37060	No. 174	0.546527778	7.8	0.81	0.72	0.074	0.0000571	12.1	0.5	6.05	250	0.8	200	4	1	4	-7.4
37060	No. 175	0.548611111															
37060	No. 177	0.572916667	7.8	0.81	0.72	0.074	0.0000566	12.1	0.5	6.05	250	0.8	200	3.83	1	3.83	-7.4
37060	No. 178	0.581944444	7.8	0.81	0.72	0.074	0.0000572	12	0.5	6	250	0.8	200	3.95	1	3.95	-7.2
37060	No. 181	0.604166667	7.8	0.81	0.72	0.074	0.000057	11.9	0.5	5.95	250	0.8	200	3.96	1	3.96	-7.2
37060	No. 182	0.611111111	7.8	0.81	0.72	0.074	0.000057	11.9	0.5	5.95	250	0.8	200	3.96	1	3.96	-7.2
37060	No. 185	0.638194444	7.8	0.81	0.72	0.074	0.0000567	11.9	0.5	5.95	250	0.8	200	3.91	1	3.91	-7.2
37060	No. 186	0.64375	7.8	0.81	0.72	0.074	0.0000569	11.9	0.5	5.95	250	0.8	200	3.98	1	3.98	-7.2

Appendix III: Receiver and Antenna Specifications

The instrumentation used for these measurements comprised an HP 8572A receiver, an HP 8447F Option H64 dual preamplifier used before the HP 8572A receiver, two compound cables used to connect the antennas to the preamplifier and/or receiver, and five antennas. Preamplifier 1 of the HP 8447F provided 28 dB (9 kHz - 50 MHz) to the HP 8572A input 1; preamplifier 2 increased the sensitivity of input 2 of the HP 8572A by 25 dB (100 kHz - 1.3 GHz). Characteristics of the receiver, antennas and cables are presented below.

HP 8572A EMC Receiver Specifications and Characteristics

The HP 8572A receiver is capable of making measurements in an 20 Hz to 22 GHz frequency range. It comprises an HP 8566B spectrum analyzer with Options 002 and 462, an HP 85685A RF preselector, an HP 11713A attenuator/switch driver, an HP 8449B Option H01 preamplifier, and an HP 85650A quasi-peak adapter (not used during these tests). This instrumentation was operated using HP 85869PC EMI measurement software. The frequency and sensitivity amplitude specifications of this receiver are listed below.

Frequency Specifications

Frequency Range: 20 Hz to 22 GHz

Frequency Readout Resolution [Fixed-Tuned (Zero Span)]: 1 Hz

Frequency Accuracy

[Fixed-tuned (Zero Span)]:

$$\pm (\text{frequency reference error} \times \text{tuned frequency} + \text{bandwidth center frequency error} + 10 \text{ Hz})$$

[In Swept Scanning Mode]

$$\text{Spans } \leq n \times 5 \text{ MHz: } \pm 2\% \text{ of frequency span} + \text{frequency reference error} \times \text{tuned frequency} + \text{bandwidth center error}^1 + 10 \text{ Hz}$$

$$\text{Spans } > n \times 5 \text{ MHz: } \pm (2\% \text{ of frequency span} + n \times 100 \text{ kHz} = \text{frequency reference error} \times \text{tuned frequency} + \text{bandwidth center error} + \text{center} + 10 \text{ Hz})$$

where n is the harmonic mixing number, depending on center frequency as shown below:

$$n = 1 \text{ for } 20 \text{ Hz to } 5.8 \text{ GHz center frequency}$$

$$n = 2 \text{ for } 5.8 \text{ GHz to } 12.5 \text{ GHz center frequency}$$

$$n = 3 \text{ for } 12.5 \text{ GHz to } 18.6 \text{ GHz center frequency}$$

$$n = 4 \text{ for } 18.6 \text{ GHz to } 22.0 \text{ GHz center frequency}$$

Examples:

<u>Center Freq.</u>	<u>Freq. Span</u>	<u>Bandwidth</u>	<u>Freq. Accuracy</u>
100 Hz	100 Hz	10 Hz	$\pm 15 \text{ Hz (Char.)}$
10 kHz	1 kHz	10 Hz	$\pm 33 \text{ Hz (char.)}$
1 MHz	100 kHz	1 kHz	$\pm 2.31 \text{ kHz (char.)}$
1 GHz	10 MHz	100 kHz	$\pm 330 \text{ kHz (char.)}$
10 GHz	100 MHz	300 MHz	$\pm 2.29 \text{ MHz (Char.)}$

After adjusting FREQ ZERO at stabilized temperature.

Frequency Span Readout Accuracy

Spans $\leq n \times 5 \text{ MHz}$

$\pm 1\%$ of indicated frequency separation.

Spans $> n \times 5 \text{ MHz}$

$\pm 3\%$ of indicated frequency separation.

Amplitude Specifications and Characteristics

Displayed Average Noise Level

Input 1 and Input 2 (HP 85685A) with 0 dB HP 85685A and HP 8566 B attenuation

Displayed average Noise Level typically > 3 dB lower than specifications;
 Noise with Peak Detection typically 8 dB higher than Displayed Average Noise;
 Noise with Quasi_PeAK Detection typically 5 dB higher than Displayed Average Noise Level.

20 Hz to 9 kHz	See Graph below
9 Hz to 150 kHz	30 dB noise figure (characteristic) < - 25 dB μ V with 10 Hz resolution bandwidth < - 12 dB μ V with 200 Hz C.I.S.P.R. bandwidth
150 kHz to 1 MHz	< 30 dB noise figure 1 (characteristic) < - 25 dB μ V with 10 Hz resolution bandwidth , + 4 dB μ V with 9 kHz C.I.S.P.R. bandwidth
1 MHz to 30 MHz	< 13 dB noise figure (characteristic) < - 43 dB μ V with 10 Hz resolution bandwidth < 13 dB μ V with 9 kHz C.I.S.P.R. bandwidth
30 MHz to 1.5 GHz	< 13 dB noise figure (characteristic) < - 43 dB μ V with Hz resolution bandwidth < - 1 dB μ V with 120 kHz C.I.S.P.R. bandwidth
1.5 GHz to 2.0 GHz	< 15 dB noise figure (characteristic) < - 40 dB μ V with 10 Hz resolution bandwidth + 2 dB μ V with 120 kHz C.I.S.P.R. bandwidth

Input 3 (HP 8449B)

0 HP 8566B attenuation; 10 Hz resolution bandwidth with Gain Correction Factor Applied

1.0 GHz to 5.8 GHz	< 10 dB noise figure (characteristic) < - 45 dB μ V
5.8 GHz to 12.5 GHz	< 13 dB noise figure (characteristic) < - 42 dB μ V
12.5 GHz to 18.6 GHz	< 19 dB noise figure (characteristic) < - 36 dB μ V
18.6 GHz to 22.0 GHz	< 23 dB noise figure (characteristic) < - 32 dB μ V

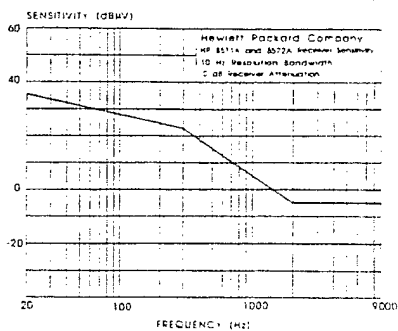

Measurement Range

Input 1 (HP 85685A) and Input 2 (HP 85685) (20 Hz to 3 GHz)	+ 137 dB μ V to 3 dB above the Displayed Average Noise Level (characteristic)
T01 Within RF Passband	92 dB μ V (characteristic)
Outside RF Passband	127 dB μ V (characteristic)
S01 Within RF Passband	127 dB μ V (characteristic)
Outside RF Passband	147 dB μ V (characteristic)
Input 3 (HP 8449B) (1 to 22 GHz)	+ 70 dB μ V to 3 dB above the Displayed Average noise Level(characteristic)
T01	74 dB μ V (characteristic)
S01	97 dB μ V (characteristic)

Absolute Amplitude Accuracy*

Input 1 (HP 85685A) and Input 2 (HP 85685A)	20 Hz to 2.0 GHz
10 dB HP 8566B attenuation	$\leq \pm 2\text{dB}\ddagger$ (Meets C.I.S.P.R. Publication 16 specs)
0 dB HP 8566B attenuation	$< +2.5\text{B}\ddagger$
Input 3 (HP 8449B)	1 GHz to 22 GHz
	$\leq \pm 2\text{dB}\ddagger$

* After 2 hour warm-up. Ambient temperature 20 to 30°C.

Peak of signal in top 7 divisions of display for log mode.

Peak of signal in top 9-1/2 divisions for linear mode.

† After Performing system calibration using HP 85685A comb generator.

HP 8568A attenuation 0 to 40 dB (20 Hz to 200 kHz).

HP 85685A attenuation 0 to 20 dB (200 kHz to 3 GHz).

HP 85685A attenuation 0 to 30 dB (200 kHz to 2 GHz using C.I.S.P.R. bandwidths).

Power level at HP 85685A input connector $\leq (-40\text{ dBm} + \text{HP 85685A attenuation})$.

‡ After performing Input 3 system calibration.

HP 8566B attenuation 0 or 10 dB. With Gain Correction Factor applied.

Using HP 8566B Preselector-Peak.

Gain Compression

Input 1 (HP 85685A) and Input 2 (HP 85685A)	
0 dB HP 8566B attenuation 0 dB HP 85685A attenuation	
Within RF Passband	$< 1\text{ dB}$ for input signal levels $\leq 77\text{ dB}\mu\text{V}$ (characteristic)
Outside RF Passband	$< 1\text{ dB}$ for input signals levels $\leq 117\text{ dB}\mu\text{V}$ (characteristic)
Input 3 (HP 8449B)	$\leq 1\text{ DB}$ for input signal levels $< 70\text{ dB}\mu\text{V}$ (characteristic)
10 dB HP 8566B attenuation	

Antenna Characteristics

Four different antennas were used to measure the radiated electromagnetic field for four different frequency ranges. The frequency-dependent conversion factor (called the antenna factor) in dB form is added to the measured voltage to infer the field. All transducers were designed to meet MIL-STD 461/462 and were manufactured by EMCO.

The manufacturer supplied calibration factors for the transducers. The electromagnetic antennas included calibrations only for one polarization. This is not a concern for the active rod antenna, which is used only in a vertical orientation. However, for the other frequency ranges, measurements for both vertical and horizontal polarization are required. Fortunately, the difference between the vertical and horizontal polarization is generally less than 1 dB. The antenna factors for all antennas, as well as the typical difference between the vertical and horizontal antenna factors for the antennas where both polarization orientations are required, are shown below. All results are presented in graphical form. The frequency ranges in which each of these antennas were used are listed in Table 3 above.

