

NBS MONOGRAPH 63

AMPTIAC

54986

**Tensile and Impact Properties of
Selected Materials From 20 to 300 °K**

DISTRIBUTION STATEMENT A
Approved for Public Release
Distribution Unlimited



20011210 055

**U.S. DEPARTMENT OF COMMERCE
NATIONAL BUREAU OF STANDARDS**

THE NATIONAL BUREAU OF STANDARDS

Functions and Activities

The functions of the National Bureau of Standards are set forth in the Act of Congress, March 3, 1901, as amended by Congress in Public Law 619, 1950. These include the development and maintenance of the national standards of measurement and the provision of means and methods for making measurements consistent with these standards; the determination of physical constants and properties of materials; the development of methods and instruments for testing materials, devices, and structures; advisory services to government agencies on scientific and technical problems; invention and development of devices to serve special needs of the Government; and the development of standard practices, codes, and specifications. The work includes basic and applied research, development, engineering, instrumentation, testing, evaluation, calibration services, and various consultation and information services. Research projects are also performed for other government agencies when the work relates to and supplements the basic program of the Bureau or when the Bureau's unique competence is required. The scope of activities is suggested by the listing of divisions and sections on the inside of the back cover.

Publications

The results of the Bureau's research are published either in the Bureau's own series of publications or in the journals of professional and scientific societies. The Bureau itself publishes three periodicals available from the Government Printing Office: The Journal of Research, published in four separate sections, presents complete scientific and technical papers; the Technical News Bulletin presents summary and preliminary reports on work in progress; and CRPL Ionospheric Predictions provides data for determining the best frequencies to use for radio communications throughout the world. There are also five series of nonperiodical publications: Monographs, Applied Mathematics Series, Handbooks, Miscellaneous Publications, and Technical Notes.

A complete listing of the Bureau's publications can be found in National Bureau of Standards Circular 460, Publications of the National Bureau of Standards, 1901 to June 1947 (\$1.25), and the Supplement to National Bureau of Standards Circular 460, July 1947 to June 1957 (\$1.50), and Miscellaneous Publication 240, July 1957 to June 1960 (includes Titles of Papers Published in Outside Journals 1950 to 1959) (\$2.25); available from the Superintendent of Documents, Government Printing Office, Washington 25, D.C.

UNITED STATES DEPARTMENT OF COMMERCE • Luther H. Hodges, *Secretary*

NATIONAL BUREAU OF STANDARDS • A. V. Astin, *Director*

Tensile and Impact Properties of Selected Materials From 20 to 300 °K

K. A. Warren and R. P. Reed

54986
5100

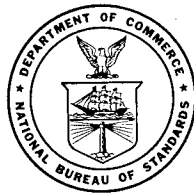

National Bureau of Standards Monograph 63

Issued June 28, 1963

For sale by the Superintendent of Documents, U.S. Government Printing Office
Washington 25, D.C. - Price 35 cents

**Reproduced From
Best Available Copy**

Library of Congress Catalog Card Number: 63-60026

Contents

	Page
Introduction.....	1
Equipment.....	1
Specimens.....	2
Experimental procedure.....	2
Reduction of data.....	3
Results.....	3
References.....	3
Data (tables I to VII).....	4
Tensile properties (figures 1 to 6).....	26
Impact properties (figures 7 to 13).....	30
Identification table (table 8).....	36
Specimen designs (figures 14 to 30).....	37

Tensile and Impact Properties of Selected Materials from 20 to 300 °K

K. A. Warren* and R. P. Reed

The tensile and ^{all} impact properties of structural materials were experimentally determined at temperatures from 20 to 300 °K. Tensile properties of a few materials were also determined at 4 °K. The materials included forty-two commercial alloys of iron, aluminum, titanium, copper, nickel, and cobalt, and two metal-bonded carbides. The properties experimentally ^{all} determined were the yield strength, ^{all} tensile strength, ^{all} elongation, and ^{all} reduction of area, the stress versus strain curve, and the impact energy. The test equipment and procedures are described. The individual data are presented in tables, and the average results are displayed in graphs.

[Cryogenic testing]

Introduction

There has been a lack of information on the low-temperature mechanical and physical properties of certain materials that might be used in cryogenic devices. Even where data existed, they were not always available in convenient form. Also the designer was sometimes faced with the necessity of choosing between conflicting data.

In order to remedy these problems insofar as certain missile applications were concerned, the Cryogenic Engineering Laboratory of the Bureau was requested by the Air Force Ballistic Missile Division to search the literature published between 1940 and 1960 for pertinent mechanical and physical properties data on selected materials at low temperatures, to evaluate these data, and to supplement them with experimental measurements at room and low temperatures where deemed advisable. This program was initiated early in 1959 under Air Force Contract Number AF 04(647)-59-3. It led to preparation of a Cryogenic Materials Data Handbook which had a limited distribution to the Air Force and some of its contractors.

This Monograph is presented to provide more detailed documentation of the experimental portion of the program and to make the results more generally available. Included are tensile strength, yield strength, elongation, and reduction of area values, stress-strain curves, and impact data for alloys of aluminum, cobalt, copper, iron, nickel, and titanium, and two metal-bonded carbides. Only one condition of each material was tested (except for beryllium copper). The condition selected was the one thought to be the most useful for low temperature missile applications. The materials were tested at four temperatures: 300 °K (room), 195 °K (dry ice and alcohol), 76 °K (boiling liquid nitrogen), and 20 °K (boiling liquid hydrogen). A few results are reported for tests made at 4 °K (boiling liquid helium).

Equipment

To implement the testing program a tensile cryostat, which has been described in the literature [1]¹, was designed and built. This cryostat is capable of transmitting tensile forces up to a maximum of 5,000 pounds. This load limit influenced the specimen design as will be subsequently described. Later in the program another cryostat [2], of a different design and capable of sustaining tensile forces of more than 10,000 pounds, was designed and built for another project. This cryostat was also used, and its use significantly accelerated the experimental program.

The tensile tests were performed using two universal testing machines, one a 60,000 pound hydraulic machine, the other a 10,000 pound mechanical machine. Both machines were equipped with 10,000 pound load cells. The load versus extension curve was plotted automatically on an *x-y* recorder. The recorders used were equipped with time plotting devices for the *x* axis so that load versus crosshead travel (time) could be recorded after the limit of travel of the extensometer was reached.

Nearly all of the specimens were equipped during testing with an extensometer to allow an accurate determination of yield strength and stress versus strain. Three types of extensometers were available. Initially a commercial clip-on strain gage extensometer built for 1-inch gage length was used. Because of the desirability of conforming to the convention that the initial gage length should equal four times the diameter of the specimen, two strain-gage type extensometers meeting this requirement were developed (fig. 1) that fit respectively the two principal types of specimens. At the same time it proved possible to greatly extend the strain range, inasmuch as the commercial extensometer had only utilized a small portion of the elastic region of the strain gages and beams. By using a different method of transmitting the strain of the specimen to the strain

*Present address: Granville-Phillips Co., Boulder, Colo.

¹ Figures in brackets indicate the literature references on page 3.

gage sensing elements of the extensometer, the full elastic region was utilized. In this method the knife edges are attached rigidly to the ends of thin beams on which are mounted the strain gages. As the specimen extends, the knife edges rotate about the contact points where they grip the specimen. Whereas the commercial extensometer was limited to measuring only slightly over 10 percent elongation, the new extensometers are linear and reproducible up to about 85 percent elongation. The strain sensitivities are about the same.

A simple cryostat was built for calibration of the extensometers at cryogenic temperatures. It consisted of a commercially available stainless steel widemouth Dewar with a cover fabricated mainly from plastic components and provided with suitable fittings, such as electrical connector, vent tube, fill tube, and calibration extension member tube, all with seals to permit use with liquid hydrogen.

The extensometers were calibrated prior to the tests by mounting them on a calibration device incorporating a precision micrometer accurate to 1×10^{-5} inches over a 2 inch range. The motion of the micrometer was transmitted into the calibration cryostat by stainless steel extension members. For low temperature calibrations the extensometer was immersed in an appropriate cryogen in the calibration cryostat. The decrease in sensitivity of the extensometers in going from room temperature to liquid hydrogen temperature was about 8 percent. This figure varied slightly with changes in, or replacements of, the strain gage transducing elements of the extensometers.

A measuring microscope was used for determining the initial and final gage lengths needed for calculation of percent elongation values. The specimen diameters were measured with a precision micrometer.

The impact measurements were conducted using a standard impact testing machine with a 15 or 30 pound hammer, and a drop in height of the hammer of 2 or 4 feet. The resulting velocity at impact is 11.3 or 16.0 feet per second.

Specimens

Because of the limited load capacity of the first tensile cryostat, as mentioned earlier, it was necessary to use subsize tensile specimens, since the tensile strengths of some of the materials were expected to approach 300,000 psi and many would approach 200,000 psi at low temperatures. Thus, these two strength values and the 5000 pound load limit were used as a basis for determining two tensile specimen designs which incorporated nominal reduced section diameters of 0.144 inches and 0.177 inches respectively (fig. 2). Selection of the particular diameter to be used for each material was based on its expected maximum tensile strength at low temperatures. Exceptions to these standard specimen designs were the Elgiloy and 301 XFH specimens.

Initial tests of Elgiloy showed it to be considerably stronger than anticipated at low temperatures; thus a reduced section diameter of 0.125 inch was used. Since the 301 XFH stainless steel was available only in sheet form, flat tensile specimens 0.040 inch thick were used for this material (fig. 2).

The reduced section of each specimen was tapered slightly toward the center (by about 0.003 inch on the diameter or width) in an attempt to prevent the occurrence of fractures outside the gage length markings. A tolerance of ± 0.1 inch was placed on the axial location of the minimum diameter. Very short and shallow gage length marks were put on each specimen using a carbide scribe and a guide. Measuring reference points were indicated with short marks applied normal to and across the gage marks. The tolerance on coaxiality of thread axis and reduced section axis was set at 0.0002 inch. This close tolerance was provided to reduce the effects of eccentricity which would be accentuated by the smallness of the specimens.

The impact specimen designs were standard Charpy U, Charpy V, and subsize ($\frac{1}{2}$) Charpy V (fig. 2). Subsize specimens were used for materials which exhibited an impact strength greater than 110 foot-pounds or which did not completely fracture during preliminary tests with standard size specimens. The notch contour of the specimens was checked using an optical comparator. The tolerances of the notch radius, specimen width, and specimen thickness from the bottom of the notch to the opposite side were ± 0.001 inch.

It was necessary to heat treat some of the materials (A286, 17-4PH, 17-7PH, 1075, Unimach #1) before specimen manufacture. The data spread which occurred in some of these materials can probably be attributed to variations in microstructure that were found to exist. The condition of each material is recorded in table I.

Experimental Procedure

The extensometer was mounted on the specimen, and the specimen placed in the cryostat. Parts of the cryostat were then installed in their respective locations, all electrical and mechanical connections were made and checked, and the cryostat was filled with refrigerant if a low temperature run was to be made. In using liquid hydrogen, suitable safety precautions were observed [3]. With solid CO₂-ethyl alcohol mixtures, the temperature was checked with a liquid-in-glass thermometer. Nearly all tensile tests were run with a crosshead velocity of 0.02 inch per minute. Exceptions to this are indicated.

After fracture, the broken specimen was assembled in a holder, and the final gage length was determined with the measuring microscope. An average was taken of two traverses made in opposite directions. Final diameter determinations were made by using another fixture and the precision hand micrometer. Because necking

occurred in most materials, $\frac{1}{16}$ inch diameter wires were placed between the specimen and the micrometer spindle and anvil to obtain a reliable reduced-diameter measurement.

The extensometers were calibrated periodically at all test temperatures to ensure accuracy of strain measurement recording. Also they were always calibrated after replacing component parts such as beams and strain gages. For the commercial extensometer it was often necessary to sharpen the knife edges; this change had little effect on the calibration of the extensometer.

The impact tests were conducted with the aid of a combination specimen aliner and holder which could be inserted while containing the specimen into a refrigerant bath and cooled down to the test temperature. This cool down took place quite rapidly, but extra time at temperature was allowed before removing the specimen from the bath. The transfer from the bath to the impact machine was made within 3 seconds. As the holding fixture was withdrawn it positioned the specimen properly in the supports. Immediately thereafter the hammer was allowed to drop. The liquid hydrogen tests on the subsize Charpy V specimens were performed in the same manner except that the tests were conducted outdoors for reasons of safety. Paper boats were glued to these specimens prior to the tests for the purpose of retaining the liquid hydrogen around the specimen until fracture. Without the paper boats the temperature rise of the specimens prior to fracture would have been about 30 degrees K.

Reduction of Data

The tensile strength values were computed by dividing the maximum load sustained by the specimen by its initial minimum cross-sectional area. All yield-strength values were obtained by using the 0.2 percent offset method. In a few instances where the initial portion of the stress-strain curve was distorted due to back lash in the recording system, an accurate value of the modulus of elasticity, when known for the particular material at the particular temperature, was used in conjunction with the extensometer calibration to locate the 0.2 percent offset point on the curve. The yield strength values were computed by dividing the yield load by the initial minimum cross-sectional area. The stress-strain curves in figures 3 to 30 were derived from the continuously recorded load versus strain and crosshead extension plots and were adjusted to the average values of yield strength, tensile strength, and elongation.

The percent elongation values are based on a 4D gage length. The one exception to this is the 301 XFH stainless steel for which a 1-inch gage length was used.

For high elongation materials it was often necessary to switch to a crosshead movement measurement system before fracture occurred, due to the limited travel of the extensometers. The effective gage length was somewhat indefinite for

this portion of the stress-strain curve. For this reason some of the tabulated elongations do not agree exactly with those that might be calculated from the stress-strain diagrams. The latter should be given no weight.

Careful consideration was given to data accuracy. Stress data are reported to 4 place accuracy and elongation and reduction of area data are reported to 3 places. When experimental results occurred which could be attributed to a variation in experimental procedure (such as fracturing on the gage length marking) the results were not reported. The authors conclude that the reason for the data spread is specimen material inconsistency, not experimental technique.

The averages of the impact energies in some cases include both "high drop" and "low drop" readings. However the results are not indexed as to height of drop inasmuch as no significant effect due to this variable was found. In cases where a large spread in the impact data exists, this can again be partially attributed to variations of microstructure. Where fracture was incomplete the percent fracture reported in the impact results is an approximate figure based on visual estimation of the fracture surfaces of the specimens which had been tested. The energy absorbed values are reported to the nearest 0.5 foot-pound of energy in tables II-VIII.

Results

The results of the tests performed on individual specimens are reported and averaged in tables II-VIII. The material condition and tensile specimen configuration (with reference to fig. 2) are noted in the "Material" column.

Figures 3 through 30 show typical stress-strain curves, the temperature dependences of the average tensile properties, and the average values of impact energy absorbed for each material. Chemical composition, condition, grain size, and room-temperature hardness for each material are listed in table I.

The authors acknowledge the assistance of the following who contributed to the experimental program: R. P. Mikesell, R. M. McClintock, T. F. Durham, C. J. Guntner, R. L. Greeson, G. W. Pickering, F. M. Reames, H. P. Gibbons, and many others. Of particular help in preparation of this Monograph was Mrs. C. J. Dallman, who did the typing.

References

- [1] R. M. McClintock and K. A. Warren, Tensile cryostat for the temperature range 4 to 300 °K, Materials Research and Standards, ASTM Bulletin, V. 1, \$2, p. 95-98 (1961).
- [2] R. P. Reed, A cryostat for tensile tests in the temperature range 300 to 4 °K, Advances in Cryogenic Engineering, V. 7, paper K-3, p. 448-454, (Plenum Press, 1961).
- [3] D. Chelton, Safety in the use of liquid hydrogen, The Technology and Use of Liquid Hydrogen, Editors W. H. Denton, R. B. Scott, and C. M. Nicholls (Pergamon Press, London, to be published).

TABLE I. IDENTIFICATION OF THE MATERIALS.

Materials	Form	Condition	C	Ti	Mn	Si	Ni	Cr	Fe	Mg	Cu	Zn	Co	W	Others	Hardness	ASTM Grain Size	
<u>Aluminum Alloys</u>																		
<u>TENS-50</u>																		
	Specimen	Sand cast, T6	*	.2		8.2			.2	.4					Be-.1	R _B 60		
356	3/4" bar	Chill cast, T6	*	.1		6.9			.2	.2	.1					R _B 41		
1100	3/4" bar	0	*			.1			.6		.2					R _H 53	3.5	
2020	3/4" bar	T6	*		.5	.1			.1		4.3				Li-1.1 Cd-.2	R _B 91	7	
2024	3/4" bar	T86	*		.5	.1			.2	1.4	4.1	.1				R _B 83	8	
6061	3/4" bar	T6	*	.2	.2	.6	.3	.7	.7	1.0	.3	.3				R _B 51	5	
7075	3/4" bar	T6	*	.2	.3	.5	.3	.7	.7	2.5	1.6	5.6				R _B 90	7	
<u>Cobalt Alloys</u>																		
Elgiloy	3/8" bar	Cold reduced 45%	.15		2.0		15.0	20.0	16.0				40.0		Mo-7.0	R _C 46	4	
Stellite 3	3/4" bar	Sand cast	2.45				3.0	30.5	3.0					12.5		R _C 55		
Stellite 25	3/4" bar	Cold reduced 26%	.07		1.6	.6	10.0	20.2	2.4					15.2	P-.01 S-.01	R _C 41	2	
<u>Copper Alloys</u>																		
Berylico 25	3/4" bar	Annealed	*			.1			.1				.2		Be-1.8 Al-.1	R _B 55	9	
Berylico 25	3/4" bar	Hard	*			.1			.1				.2		Be-1.8 Al-.1	R _B 95	9.5	
70/30 Brass	3/4" bar	3/4 Hard	*													R _B 88	8.5	
OFHC Copper	3/4" bar	"Soft" Annealed	*													R _H 86	5	

Copper and Silver = 99.99

1405 -

AP 177

TABLE I. IDENTIFICATION OF THE MATERIALS (Continued)

Material	Form	Condition	C	P	S	Ni	Cr	Mo	Mn	Si	Al	Cu	Others	Hardness	ASTM Grain Size
Iron Alloys															
Invar 36	3/4" bar	12-15% cold drawn	.08	.01	.01	36.0			.8	.4			Se-.2	R _B 95	7
NiSpan "C"	3/4" bar	Age hardened 1200°F - 5 hrs., AC, tempered	.03		.01	42.7	5.1		.5		.4	.1	Ti-2.5	R _C 35	8
Unimach #1 (Vascojet 1000)	3/4" bar	Heat treated 1850°F - 1 hr., AC, Double tempered 1025°F - 3/4 hr. **	.41	.02	.01		4.9	1.4	.3	.9			V-.4	R _C 52 tensile, R _C 56 impact	5
17-4PH	3/4" bar	H 1100 **	.03	.02	.01	4.3	16.0		.2	.5		3.6	Cb-.2	R _C 38	8
17-7PH	3/4" bar	TH 1050 **	.07	.02	.01	7.4	17.2		.7	.4	1.2			R _C 42	7
A-286	3/4" bar	Solution treated 1800°F - 1-1/2 hrs., AC, Aged 1350°F - 16 hrs., AC**	.04	.01	.01	25.4	14.8	1.2	1.4	.6	.2		Ti-2.1 V-.3	R _C 30	7
301	.039" sheet	Extra full hard	.09	.02	.01	6.8	17.6	.2	.7	.4		.1			
302	3/4" bar	Cold drawn to 125,000 psi. *	.08	.02	.01	8.7	18.6		.6	.6				R _C 31	4
303	3/4" bar	Annealed *	.10	.03	.29	8.7	17.6	.4	1.2	.6		.4		R _B 95	7
304L	3/4" bar	Annealed *	.02	.02	.01	9.7	18.4		1.4	.6				R _B 94	3
310	3/4" bar	Annealed *	.08	.02	.02	20.8	24.8	.1	1.7	.7		.1		R _B 79	2
321	3/4" bar	Annealed *	.06	.02	.02	9.8	17.9	.2	1.4	.6		.3	Ti-.4	R _B 97	6
347	3/4" bar	Annealed *	.06	.02	.02	10.3	18.0	.2	1.5	.6		.2	Cb-.9	R _B 95	9
410	3/4" bar	Heat treated 1800°F - 1 hr., OQ, tempered 700°F - 4 hrs., AC	.12	.02	.01		12.2		.5	.2				R _C 42	4
416	3/4" bar	Heat treated 1800°F - 1 hr., OQ, tempered 700°F - 4 hrs., AC	.13	.02	.22		12.6	.4	.5	.6				R _C 41	6
440C	3/4" bar	Heat treated 1875°F - 1/2 hr., OQ, Double tempered 1000°F - 6 hrs. and 1050°F - 6 hrs.	1.08	.02	.01		17.3	.6	.5	.4				R _C 40	6
1075	3/4" hex. bar	Heat treated 1450°F - 1 hr., OQ, tempered 720°F - 1 hr., AC	.80						.30	.15				R _C 43	9
2800 (9% Ni)	3/4" bar	Double normalized 1650°F and 1450°F, tempered 1050°F - 2 hrs.	.09	.02	.02	8.8	.2		.71	.1				R _C 29	9
4340	3/4" bar	Cold drawn and annealed *	.39	.02	.02	1.8	.8	.3	.7	.3				R _C 32	8

50.44.2

TABLE I. IDENTIFICATION OF THE MATERIALS (Continued)

Material	Form	Condition	Chemical Composition (per cent)										Hardness	ASTM Grain Size	
			C	S	Si	Mn	Cr	Al	Fe	Ti	Cu	H ₂			Others
<u>Nickel Alloys</u>															
Inconel 600	3/4" bar	20% Cold drawn *	.04	.01	.2	.2	15.5	7.3			.01			R _C 27	6
Inconel "X"	3/4" bar	Hot rolled, direct aged 1300°F - 20 hrs., AC, tempered	.05	.01	.3	.6	15.4	.9	7.0	2.5				R _C 39	7
"K" Monel	3/4" bar	Age hardened 1100°F - 21 hrs., 1000°F - 8 hrs., AC	.15	.01	.3	.4	2.9	1.2	.5	30.9				R _C 35	7
"S" Monel	Rough Cast Specimen Configuration	Cast, annealed 1600°F - 1 hr., 1300°F - 1/2 hr., OQ	.03		4.1	.7	1.8			27.7				R _C 25	
"A" Nickel	3/4" bar	Annealed 1725°F - 1/2 hr.	.06	.01		.3	.1							R _B 70	2
René 41	3/4" bar	Solution treated 1975°F - 4 hrs., WQ	.09	.01	.2	18.8	1.4	1.3	3.2					R _C 39	8
<u>Titanium Alloys</u>															
5Al-2.5Sn, (A-110AT)	3/4" bar	Annealed *	.07				5.5	.2			.02			R _C 35	
13V-11Cr-3Al (B-120 VCA)	3/4" bar	Solution treated *	.03				10.8	3.0	.2		.01			R _C 34	
6Al-4V (C-120 AV)	3/4" bar	Annealed *	.01				6.2	.1			.01			R _C 36	7.5
<u>Carbides</u>															
TiC	Specimen	Sintered *	9.2				2.5	2.5		41.0				R _C 60	
WC (Ca-10)	Specimen	Sintered *					13% Cobalt, Balance Tungsten Carbide							R _C 72	

* Reported condition represents standard mill heat treating procedure. General data regarding this procedure may be found in the company brochures.

** Heat treatment performed at NBS.

TABLE II ALUMINUM ALLOYS

MATERIAL	Test Temp °K	TENSILE PROPERTIES					IMPACT PROPERTIES		
		Crosshead Velocity	Tensile Strength	Yield Strength (0.2% offset)	Elongation	Reduction of Area	Energy Absorbed	Charpy Geometry	Fracture Area
		in/min	psi	psi	% in 4D	%	ft-lb		%
TENS 50 Sand Cast T6 Specimen Type A	Room	0.01	44,200	---	---	---	2.5		
		0.01	41,100	31,500	4.3	8.7	2.5		
		0.01	40,400	32,200	3.3	9.8	2.5		
		0.01	39,300	32,200	---	9.7			
		0.01	42,500	33,200	5.5	9.7			
		0.01	42,400	33,000	---	---			
		avg	41,600	32,400	4.4	9.4	2.5	V	100
	195	0.01	43,000	35,400	3.4	5.9	2.5		
		0.01	43,100	---	3.9	8.8	2.5		
		0.01	47,200	37,800	4.8	10.8	2.5		
			avg	44,400	36,600	4.0	8.5	2.5	V
	76	0.01	55,400	38,300	6.2	9.1	2.0		
0.01		52,100	---	3.6	6.9	1.0			
0.01		46,300	38,800	2.5	6.6	1.5			
0.01		53,400	---	---	3.6	1.5			
0.01		47,600	39,400	---	9.5	1.5			
0.01		45,000	38,300	1.4	3.0				
0.01		51,000	---	3.1	4.7				
0.01		50,200	35,700	2.4	7.1				
0.01		51,300	---	2.4	6.7				
		avg	50,300	38,100	3.1	6.4	1.5	V	100
20	0.01	55,900	43,600	2.6	4.4				
	0.01	57,000	44,600	3.0	5.1				
		avg	56,400	44,100	2.8	4.8			
356 Cast T6 Specimen Type A	Room	0.02	40,500	28,700	10.7	11.8	2.0		
		0.02	36,500	23,300	12.0	13.6	2.0		
		0.02	36,100	22,700	15.8	18.4	2.0		
			avg	37,700	24,900	12.8	14.6	2.0	V
	195	0.02	39,300	---	12.3	12.5	2.0		
		0.02	38,200	24,700	---	---	3.5		
		0.02	38,300	24,800	11.7	13.4	2.5		
			avg	38,600	24,800	12.0	13.0	2.0	V
	76	0.02	48,800	28,400	11.1	11.6	2.5		
		0.02	48,600	25,800	---	12.3	2.5		
		0.02	47,000	27,100	10.0	9.6	1.5		
			avg	48,100	27,100	10.6	11.2	2.5	V
20		0.02	60,700	35,600	7.2	6.9			
		0.02	60,400	33,200	10.9	11.2			
		avg	60,600	34,400	9.0	9.0			

TABLE II ALUMINUM ALLOYS (Continued)

MATERIAL	Test Temp °K	TENSILE PROPERTIES				IMPACT PROPERTIES			
		Crosshead Velocity	Tensile Strength	Yield Strength (0.2% offset)	Elongation	Reduction of Area	Energy Absorbed	Charpy Geometry	Fracture Area
		in/min	psi	psi	% in 4D	%	ft-lb		%
1100 0 Specimen Type A	Room	0.02	13,500	7,400	46.8	88.8	23.0		
		0.02	13,400	6,900	44.1	86.8	22.5		
		0.02	13,500	6,500	46.7	89.7	23.0		
		avg	13,500	6,900	45.9	88.4	23.0	1/2 V	50
	195	0.02	16,100	7,300	47.4	85.6	27.5		
		0.02	16,900	---	---	---	29.0		
		0.02	16,500	7,100	52.5	85.7	28.0		
		avg	16,500	7,200	50.0	85.6	28.0	1/2 V	50
	76	0.02	27,800	---	55.8	81.6	35.5		
		0.02	27,900	9,100	57.0	82.2	36.5		
		0.02	27,300	8,900	---	79.7	33.5		
		avg	27,700	9,000	56.4	81.2	35.0	1/2 V	50
20	0.02	47,400	9,600	52.6	57.8	33.5			
	0.02	47,700	9,300	55.7	62.1	31.5			
						30.0			
	avg	47,600	9,400	54.2	60.0	31.5	1/2 V	75	
2020 T6 Specimen Type A	Room	0.02	83,400	74,900	9.9	16.4	1.5		
		0.02	82,600	74,100	9.8	16.6	1.5		
		0.02	82,000	73,400	10.4	16.8	1.5		
		avg	82,700	74,100	10.0	16.6	1.5	V	100
	195	0.02	89,400	78,100	6.9	8.8	1.5		
		0.02	90,200	79,600	6.5	7.5	1.5		
							1.5		
		avg	89,800	78,800	6.7	8.2	1.5	V	100
	76	0.02	99,300	86,800	5.3	6.2	1.5		
		0.02	99,400	87,300	5.2	6.6	1.5		
							1.5		
		avg	99,400	87,000	5.2	6.4	1.5	V	100
20	0.02	110,300	93,300	7.3	9.0				
	0.02	108,600	92,400	7.9	10.2				
	avg	109,400	92,800	7.6	9.6				
2024 T86 Specimen Type A	Room	0.02	74,300	---	9.9	25.7	3.5		
		0.02	73,900	71,600	9.4	26.5	3.0		
		0.02	74,300	71,500	9.5	26.8	3.5		
		0.02	---	---	9.3	27.3	3.0		
	avg	74,200	71,600	9.5	26.6	3.5	V	100	
	195	0.02	79,900	76,500	9.6	24.1	3.0		
		0.02	80,100	76,100	9.1	22.3	3.0		
							3.0		
		avg	80,000	76,300	9.4	23.2	3.0	V	100
	76	0.02	91,100	85,500	10.8	20.8	3.5		
		0.02	92,400	85,700	10.6	21.9	3.5		
							3.5		
avg		91,800	85,600	10.7	21.4	3.5	V	100	
20	0.02	104,400	93,000	14.6	25.8				
	0.02	105,400	93,300	15.6	23.1				
	avg	104,900	93,200	15.1	24.4				

TABLE II ALUMINUM ALLOYS (Continued)

MATERIAL	Test Temp °K	TENSILE PROPERTIES				IMPACT PROPERTIES			
		Crosshead Velocity	Tensile Strength	Yield Strength (0.2% offset)	Elongation	Reduction of Area	Energy Absorbed	Charpy Geometry	Fracture Area
		in/min	psi	psi	% in 4D	%	ft-lb		%
6061 T6 Specimen Type A	Room	0.02	44,600	39,300	18.5	56.3	16.0		
		0.02	44,200	39,200	17.7	55.7	16.0		
		avg	44,400	39,200	18.1	56.0	16.0	V	100
	195	0.02	48,600	42,100	19.4	54.2	16.0		
		0.02	48,600	42,100	19.8	54.0	16.0		
		avg	48,600	42,100	19.6	54.1	16.0	V	100
	76	0.02	59,900	47,900	24.7	51.4	16.5		
		0.02	59,700	47,700	24.2	51.0	16.0		
							16.0		
							17.0		
							16.5		
		avg	59,800	47,800	24.4	51.2	16.5	V	100
20	0.02	75,400	51,700	29.4	45.8				
	0.02	76,000	51,900	30.2	43.4				
	avg	75,800	51,800	29.8	44.6				
7075 T6 Specimen Type A	Room	0.02	80,600	72,100	15.3	35.8			
		0.02	82,100	73,900	15.2	34.6			
		0.02	81,800	---	15.3	34.3			
		avg	81,500	73,000	15.3	34.9			
	195	0.02	87,200	79,000	14.4	27.7			
		0.02	87,800	78,900	13.9	27.2			
		avg	87,500	79,000	14.2	27.4			
	76	0.02	99,700	89,700	14.2	24.2			
		0.02	99,400	89,300	14.9	24.6			
		avg	99,600	89,500	14.6	24.4			
	20	0.02	115,000	97,900	15.2	21.3			
		0.02	115,700	101,400	15.0	21.4			
avg		115,400	99,600	15.1	21.4				

TABLE III COBALT ALLOYS

MATERIAL	Test Temp °K	TENSILE PROPERTIES				IMPACT PROPERTIES				
		Crosshead Velocity	Tensile Strength	Yield Strength (0.2% offset)	Elongation	Reduction of Area	Energy Absorbed	Charpy Geometry	Fracture Area	
		in/min	psi	psi	% in 4D	%	ft-lb		%	
ELGILOY Cold reduced 45% Specimen Type C	Room	0.02	245,700	209,200	12.0	47.2				
		0.02	251,000	210,000	10.4	45.7				
		avg	248,400	209,600	11.2	46.4				
	195	0.02	271,400	210,800	11.7	44.6				
		0.02	271,700	213,500	13.2	44.1				
		avg	271,600	212,200	12.4	44.4				
	76	0.02	321,700	251,500	14.7	32.8				
		0.02	326,000	255,600	14.5	34.7				
		avg	323,800	253,600	14.6	33.8				
	20	0.02	362,300	284,000	6.4	32.3				
		0.02	361,300	278,900	7.0	30.4				
		avg	361,800	281,400	6.7	31.4				
STELLITE 3 Sand Cast	Room						0.5			
							1.0			
							1.0			
	195							0.5		
								0.5		
		avg						0.5	V	100
	76							0.5		
								0.5		
		avg						0.5	V	100
	STELLITE 25 Cold reduced 26%	Room						35.0		
								38.0		
								37.0		
195								36.5	U	100
								31.5		
								33.0		
76								33.0		
								32.5	U	100
		avg						22.5		
20								25.0		
								23.0		
		avg						23.5	U	100

TABLE IV COPPER ALLOYS

MATERIAL	Test Temp °K	TENSILE PROPERTIES					IMPACT PROPERTIES		
		Crosshead Velocity	Tensile Strength	Yield Strength (0.2% offset)	Elongation	Reduction of Area	Energy Absorbed	Charpy Geometry	Fracture Area
		in/min	psi	psi	% in 4D	%	ft-lb		%
BERYLCO 25 Annealed Specimen Type A	Room	0.02	69,200	26,900	62.4	79.7	102.0		
		0.02	70,600	27,800	62.9	79.4	101.5		
		avg	69,900	27,400	62.6	79.6	102.5	U	50
	195	0.02	74,700	34,500	68.9	77.6	90.5		
		0.02	75,100	34,900	69.0	80.5	103.0		
		avg	74,900	34,700	69.0	79.0	103.5	U	50
	76	0.02	98,900	49,700	72.8	75.7	83.5		
		0.02	99,200	49,200	66.7	69.9	86.5		
		avg	99,000	49,400	69.8	72.8	90.0	U	75
	20	0.02	117,900	58,500	69.9	71.0			
		0.02	116,600	57,800	68.1	68.5			
		avg	117,200	58,200	69.0	69.8			
BERYLCO 25 Hard Specimen Type A	Room	0.02	101,800	96,100	19.6	68.0	37.5		
		0.02	101,700	97,200	18.8	68.0	36.5		
		avg	101,800	96,700	19.2	68.0	39.0	U	75
	195	0.02	107,700	99,200	23.7	69.6	39.5		
		0.02	109,200	101,000	22.1	70.1	42.0		
		avg	108,400	100,100	22.9	69.8	38.0	U	75
	76	0.02	131,000	120,300	31.5	66.1	34.0		
		0.02	132,800	117,200	30.5	65.8	35.0		
		avg	131,900	118,800	31.0	66.0	35.0	U	100
	20	0.02	153,700	117,900	31.4	60.0			
		0.02	153,800	120,200	31.4	60.0			
		avg	153,800	119,000	31.4	60.0			

TABLE IV COPPER ALLOYS (Continued)

MATERIAL	Test Temp °K	TENSILE PROPERTIES				IMPACT PROPERTIES			
		Crosshead Velocity	Tensile Strength	Yield Strength (0.2% offset)	Elongation	Reduction of Area	Energy Absorbed	Charpy Geometry	Fracture Area
		in/min	psi	psi	% in 4D	%	ft-lb		%
70/30 BRASS 3/4 Hard Specimen Type A	Room	0.02	96,100	66,400	14.2	58.3	14.0		
		0.02	95,100	57,300	14.2	58.2	14.0		
		0.02	94,900	58,900	14.2	58.4	15.5		
		0.05	94,600	---	---	---	18.0		
		avg	95,200	60,900	14.2	58.3	15.5	V	100
	195	0.02	100,700	60,400	16.6	62.8	15.5		
		0.02	100,800	68,500	16.8	61.6	15.5		
		0.02	100,700	63,500	18.2	63.3	16.0		
		0.02	100,500	64,100	17.9	61.2			
		0.02	101,400	65,100	17.2	62.4			
	avg	100,800	64,300	17.3	62.3	15.5	V	100	
	76	0.02	118,500	70,400	27.6	63.0	15.0		
		0.02	115,400	66,800	29.1	63.8	14.5		
							18.5		
						15.5			
						14.0			
avg	117,000	68,600	28.4	63.4	15.5	V	100		
20	0.02	133,200	74,200	32.4	58.5				
	0.02	131,800	72,600	32.1	58.0				
	avg	132,500	73,400	32.2	58.2				
OFHC Soft Specimen Type A	Room	0.02	31,800	10,700	54.2	85.1	52.5		
		0.02	31,900	10,800	53.4	87.7	52.0		
		0.2	32,500	10,500	---	---	53.0		
		0.2	32,500	10,600	---	85.4			
		0.2	32,500	12,000	---	86.5			
	avg	32,200	10,900	53.8	86.2	52.5	1/2 V	25	
	195	0.02	38,500	10,300	53.1	83.8	57.0		
		0.02	39,200	9,200	53.3	84.0	56.5		
		0.2	39,800	14,600	---	84.3	57.5		
		0.2	39,400	11,100	---	---			
		0.2	38,800	12,700	---	85.7			
	avg	39,100	11,600	53.2	84.5	57.0	1/2 V	25	
	76	0.02	51,500	13,100	59.8	82.6	67.0		
		0.02	51,100	10,100	60.8	85.4	62.0		
0.02		52,300	---	59.7	85.6	66.5			
0.2		52,500	15,600	---	84.3				
0.2		52,700	12,300	---	---				
0.2	53,100	12,800	---	82.8					
avg	52,200	12,800	60.1	84.1	65.5	1/2 V	25		
20	0.02	59,400	14,900	70.7	83.4	64.0			
	0.02	59,900	10,200	67.8	83.8	62.5			
	0.02	61,300	10,800	68.1	---	64.5			
	0.2	61,800	13,500	---	82.6				
	0.2	61,000	15,900	---	82.3				
avg	60,700	13,100	68.9	83.0	63.5	1/2 V	25		

TABLE V IRON ALLOYS

MATERIAL	Test Temp °K	TENSILE PROPERTIES					IMPACT PROPERTIES		
		Crosshead Velocity	Tensile Strength	Yield Strength (0.2% offset)	Elongation	Reduction of Area	Energy Absorbed	Charpy Geometry	Fracture Area
		in/min	psi	psi	% in 4D	%	ft-lb		%
INVAR 36	Room	0.01	93,600	90,100	---	61.6	27.5		
		0.01	94,400	91,500	21.5	62.4	28.5		
		0.01	93,900	91,900	19.5	62.1	25.5		
		0.01	93,200	89,900	21.5	61.1			
		0.05	95,400	92,100	---	---			
	avg	94,100	91,100	20.8	61.8	27.0	U	75	
	195	0.01	111,900	104,400	27.6	61.2	26.0		
		0.01	115,100	105,200	27.9	60.4	21.0		
		0.01	115,400	105,000	28.4	58.3	24.5		
		0.01	113,600	106,800	27.9	59.7	23.0		
0.01		114,500	105,000	32.0	60.0				
0.02	115,200	104,500	---	---					
0.02	116,300	106,600	---	---					
avg	114,600	105,400	28.8	59.9	24.0	U	95		
12-15% Cold drawn Specimen Type A	76	0.01	157,800	---	25.5	59.9	21.5		
		0.01	156,300	133,600	---	61.8	23.5		
		0.01	155,700	134,100	---	62.3	23.0		
		0.01	155,700	132,700	27.6	61.7	24.0		
		0.01	155,700	132,700	27.6	61.7	23.5		
	avg	156,400	133,500	26.6	61.4	23.0	U	100	
	20	0.02	171,300	163,900	---	57.1			
		0.01	170,300	156,800	27.0	59.9			
		0.01	172,500	---	25.0	59.7			
		0.05	---	161,300	17.6	53.6			
0.02		174,300	164,500	22.9	57.8				
avg	172,100	161,600	23.1	57.6					
4	0.05	177,800	160,900	19.8	51.8				
	avg	177,800	160,900	19.8	51.8				
NiSpan "C" Age hardened at 1200°F, AC Specimen Type B	Room	0.02	174,500	112,200	24.2	51.0	18.0		
		0.02	174,100	---	---	---	18.0		
		0.02	174,400	112,100	23.9	48.9	18.0		
		avg	174,300	112,200	24.0	50.0	18.0	U	100
	195	0.02	196,700	121,300	24.7	47.6	17.0		
		0.02	188,600	119,200	29.7	49.7	17.5		
		0.02	189,500	120,200	26.8	48.1	18.0		
	avg	191,600	120,200	27.1	48.5	17.5	U	100	
	76	0.02	222,300	132,500	30.9	47.6	17.0		
		0.02	225,000	132,300	29.8	45.1	17.0		
0.02		226,800	128,700	34.1	48.4	17.0			
avg		224,700	131,200	31.6	47.0	17.0	U	100	
20	0.02	243,400	145,700	31.6	43.1				
	0.02	245,600	144,000	29.0	43.5				
	avg	244,500	144,900	30.3	43.3				

TABLE V IRON ALLOYS (Continued)

MATERIAL	Test Temp °K	TENSILE PROPERTIES				IMPACT PROPERTIES			
		Crosshead Velocity	Tensile Strength	Yield Strength (0.2% offset)	Elongation	Reduction of Area	Energy Absorbed	Charpy Geometry	Fracture Area
		in/min	psi	psi	% in 4D	%	ft-lb		%
UNIMACH #1 (Vascojet 1000) Heat treated at 1850°F, 1025°F double temper Specimen Type B	Room	0.02	299,000	236,100	10.3	38.1	8.0		
		0.02	300,900	239,500	10.0	37.2	8.0		
		avg	300,000	237,800	10.2	37.6	8.0	V	100
	195	0.02	318,500	275,200	7.4	21.9	7.0		
		0.02	317,400	---	6.7	22.3	6.5		
		0.02	318,000	257,400	8.8	29.1	5.5		
		0.02	312,100	262,400	7.0	19.7	5.5		
		avg	316,500	265,000	7.5	23.3	6.0	V	100
	76	0.02	365,400	324,000	1.4	1.1	1.5		
		0.02	350,900	302,000	0.5	0	3.0		
		0.02	340,600	300,700	0.3	0	3.0		
			avg	352,300	308,900	0.7	0.4	2.5	V
20	0.02	350,800	350,800	---	---				
	0.02	353,200	350,100	0.3	0				
	avg	352,000	350,500	0.3	0				
17-4 PH H 1100 Specimen Type B	Room	0.02	187,800	179,500	15.4	56.3	64.0		
		0.02	183,700	176,600	15.8	59.4	47.0		
							50.5		
							61.0		
							46.5		
		avg	185,800	178,100	15.6	57.8	54.0	V	100
	195	0.02	213,300	206,600	15.0	55.6	14.5		
		0.02	213,300	206,200	14.6	54.9	16.5		
		avg	213,300	206,400	14.8	55.2	15.0	V	100
	76	0.02	233,400	230,300	12.9	44.7	2.5		
		0.02	246,600	241,300	10.4	30.2	3.0		
		0.02	257,900	251,100	2.7	5.0	3.0		
avg		246,000	240,900	8.7	26.6	3.0	V	100	
20	0.02	293,100	293,100	0.7	3.7				
	0.02	---	---	1.0	5.0				
	0.02	289,900	287,100	0.8	5.1				
	avg	291,500	290,100	0.8	4.6				

TABLE V IRON ALLOYS (Continued)

MATERIAL	Test Temp °K	TENSILE PROPERTIES				IMPACT PROPERTIES			
		Crosshead Velocity	Tensile Strength	Yield Strength (0.2% offset)	Elongation	Reduction of Area	Energy Absorbed	Charpy Geometry	Fracture Area
		in/min	psi	psi	% in 4D	%	ft-lb		%
321 Annealed Specimen Type B	Room	0.02	97,900	62,800	55.7	80.4	48.5		
		0.02	97,200	61,600	54.5	78.4	46.5		
		avg	97,600	62,200	55.1	79.4	49.0	1/2 V	100
	195	0.02	151,300	53,800	44.6	72.9	42.5		
		0.02	153,000	54,900	46.4	73.3	42.5		
		0.02	154,100	59,100	46.1	71.8			
		avg	152,800	55,900	45.7	72.7	42.5	1/2 V	100
	76	0.02	229,400	---	37.8	62.9	30.0		
		0.02	220,700	64,600	38.2	58.0	34.0		
		0.02	219,800	66,200	37.1	53.3	34.5		
		0.02	221,700	46,400	38.6	65.6			
		avg	222,900	59,100	37.9	60.0	33.0	1/2 V	100
20		0.02	267,400	58,300	---	---	27.0		
		0.02	271,700	58,600	34.7	43.6	35.5		
		avg	269,600	58,500	34.7	43.6	30.5		
347 Annealed Specimen Type B	Room	0.02	103,300	64,000	55.3	76.8	52.0		
		0.02	104,200	62,800	55.4	75.5	59.5		
		avg	103,800	63,400	55.4	76.2	49.0	1/2 V	100
	195	0.02	148,400	67,200	50.2	70.6	56.0		
		0.02	143,900	69,500	50.5	70.4	57.5		
		0.02	149,100	69,700	49.9	69.3	61.5		
		avg	147,100	68,800	50.2	70.1	58.5	1/2 V	100
	76	0.02	---	60,100	---	---	53.0		
		0.02	217,400	62,500	41.7	60.0	56.0		
		0.02	216,400	60,500	41.7	57.3	54.5		
		0.02	218,600	65,500	41.1	56.3			
		avg	217,500	62,200	41.5	57.9	54.5	1/2 V	75
20		0.02	266,400	72,100	38.3	42.3	44.5		
	0.02	268,600	74,900	38.2	48.0	44.5			
	0.02	269,200	82,200	37.6	45.5				
	avg	268,100	76,400	38.0	45.3	44.5	1/2 V	75	

TABLE V IRON ALLOYS (Continued)

MATERIAL	Test Temp °K	TENSILE PROPERTIES					IMPACT PROPERTIES		
		Crosshead Velocity in/min	Tensile Strength psi	Yield Strength (0.2% offset) psi	Elongation % in 4D	Reduction of Area %	Energy Absorbed ft-lb	Charpy Geometry V	Fracture Area %
440 C Heat treated at 1875°F; 1000°F, 1050°F double temper	Room						3.5		
							3.0		
		avg					3.0	V	100
	195						1.0		
							2.0		
		avg					2.0	V	100
	76						1.0		
							1.0		
							1.0		
						1.0			
	avg					1.0	V	100	
1075 Heat treated at 1450°F, 720°F temper Specimen Type B	Room	0.02	151,100	106,200	---	---	12.5		
		0.02	142,800	93,400	17.3	57.2	18.0		
		0.02	152,000	103,000	17.8	59.2	15.5		
							16.0		
							17.5		
		avg	148,600	100,900	17.6	58.2	16.0	V	100
	195	0.02	164,700	112,100	18.7	51.8	7.0		
		0.02	162,400	109,300	17.9	51.8	7.0		
		0.02	173,600	127,000	---	57.5			
		avg	166,900	116,100	18.3	53.7	7.0	V	100
	76	0.02	224,400	---	14.5	40.9	1.5		
0.02		218,900	189,300	15.3	38.3	1.5			
0.02		228,500	201,000	8.3	11.7				
0.02		214,600	187,000	---	33.8				
		avg	221,600	192,400	12.7	31.2	1.5	V	100
20	0.02	268,300	---	1.5	5.5				
	0.02	271,200	262,900	1.4	5.7				
		avg	269,800	262,900	1.4	5.6			

TABLE V IRON ALLOYS (Continued)

MATERIAL	Test Temp °K	TENSILE PROPERTIES				IMPACT PROPERTIES			
		Crosshead Velocity	Tensile Strength	Yield Strength (0.2% offset)	Elongation	Reduction of Area	Energy Absorbed	Charpy Geometry	Fracture Area
		in/min	psi	psi	% in 4D	%	ft-lb		%
17-7 PH TH 1050 Specimen Type B	Room	0.02	219,200	204,700	11.3	35.8	2.5		
		0.02	219,500	207,200	10.4	31.2	3.5		
		avg	219,400	206,000	10.8	33.5	5.5	V	100
	195	0.02	246,600	228,100	10.4	24.0	2.5		
		0.02	244,000	229,100	8.0	17.3	2.5		
		avg	245,300	228,600	9.2	20.6	2.5	V	100
	76	0.02	271,800	265,700	0.4	0	1.5		
		0.02	273,000	267,600	0.4	0	1.5		
		avg	272,400	266,600	0.4	0	1.5	V	100
	20	0.02	239,100	---	0.3	0			
		0.02	258,500	---	0.2	0			
		0.02	237,400	---	0	0			
avg	245,000	---	0.2	0					
A - 286 Solution treated at 1800°F, Aged at 1350°F Specimen Type B	Room	0.02	160,600	111,400	25.4	49.9	57.0		
		0.02	159,500	110,800	---	48.7	55.0		
		avg	160,000	111,100	25.4	49.3	55.5	V	100
	195	0.02	176,000	120,200	29.0	51.6	55.0		
		0.02	175,600	120,400	29.1	52.0	57.0		
		avg	175,800	120,300	29.0	51.8	58.0	V	100
	76	0.02	209,100	135,300	36.2	48.3	52.0		
		0.02	209,700	135,500	35.3	50.0	52.5		
		avg	209,400	135,400	35.8	49.2	52.0	V	100
	20	0.02	235,100	150,600	36.8	43.9			
		0.02	235,500	149,800	35.5	41.8			
		avg	235,300	150,200	36.2	42.8			
301 Extra full hard Specimen Type D	Room	0.02	240,300	---	14.1	---			
		0.02	241,800	218,900	13.5	25.2			
		0.02	241,200	221,200	18.3	26.4			
	avg	241,100	220,000	15.3	25.8				
	195	0.02	267,300	222,100	16.8	25.9			
		0.02	268,000	218,800	17.1	26.3			
		avg	267,600	220,500	17.0	26.1			
	76	0.02	329,100	280,000	19.1	24.7			
		0.02	327,500	264,500	18.7	24.8			
		avg	328,300	272,200	18.9	24.8			
	20	0.02	352,700	314,700	2.7	13.2			
		0.02	352,600	---	2.7	11.6			
avg		352,600	314,700	2.7	12.4				

TABLE V IRON ALLOYS (Continued)

MATERIAL	Test Temp °K	TENSILE PROPERTIES					IMPACT PROPERTIES		
		Crosshead Velocity	Tensile Strength	Yield Strength (0.2% offset)	Elongation	Reduction of Area	Energy Absorbed	Charpy Geometry	Fracture Area
		in/min	psi	psi	% in 4D	%	ft-lb		%
2800 (9% Nickel Steel) Double normal-ized 1650°F and 1450°F; 1050°F temper Specimen Type A (except (*) type B)	Room	0.02	126,800	119,600	24.6	70.3	52.0		
		0.02	124,000	117,200	23.8	70.4	53.0		
							51.0		
		avg	125,400	118,400	24.2	70.4	52.0	U	75
	195	0.02	145,900	131,400	25.1	67.3	50.5		
		0.02	147,000	127,700	25.6	67.7	50.0		
							47.0		
		avg	146,500	129,600	25.4	67.5	49.0	U	75
	76	0.02	180,600	159,200	27.1	59.6	25.0		
		0.02	180,100	159,900*	27.2*	60.2*	25.0		
		0.02	176,800*	160,100*	25.7*	62.0*	26.0		
		avg	179,200	159,700	26.7	60.6	25.5	U	100
20	0.02	218,600*	---	13.5*	36.9*				
	0.02	220,100*	206,400*	23.1*	58.6*				
	0.02	217,700*	210,100	---	---				
	avg	218,800*	208,300*	18.3*	47.8*				
4340 Annealed	Room					11.0			
						11.5			
					11.5				
	avg					10.5			
	avg					11.0	V	100	
76	195					3.5			
						3.0			
						3.0			
						3.0			
	avg					3.0	V	100	
76	76					1.5			
						1.5			
						2.0			
						1.0			
	avg					1.5	V	100	

TABLE V IRON ALLOYS (Continued)

MATERIAL	Test Temp °K	TENSILE PROPERTIES				IMPACT PROPERTIES			
		Crosshead Velocity	Tensile Strength	Yield Strength (0.2% offset)	Elongation	Reduction of Area	Energy Absorbed	Charpy Geometry	Fracture Area
		in/min	psi	psi	% in 4D	%	ft-lb		%
302 Cold Drawn Specimen Type B	Room	0.02	129,700	97,200	62.9	75.1	54.0		
		0.02	133,000	97,600	57.2	76.9	52.0		
		avg	131,400	97,400	60.0	76.0	53.5	U	100
	195	0.02	187,200	95,700	44.7	67.7	57.0		
		0.02	189,000	97,300	45.0	69.5	56.0		
		avg	188,100	96,500	44.8	68.6	55.5	U	100
	76	0.02	258,200	101,300	37.4	56.1	46.0		
		0.02	260,600	102,700	37.8	56.0	47.0		
							51.0		
							48.5		
		avg	259,400	102,000	37.6	56.0	48.0	U	100
20	0.02	---	114,400	---	---				
	0.02	312,300	117,300	33.3	35.2				
	0.02	315,000	---	31.1	37.8				
	avg	313,600	115,800	32.2	36.5				
303 Annealed Specimen Type B	Room	0.02	109,000	60,600	71.6	71.1	34.5		
		0.02	109,800	62,100	70.4	71.6	33.0		
							34.5		
						36.5			
	avg	109,400	61,400	71.0	71.4	34.5	U	100	
	195	0.02	177,600	62,200	43.5	61.6	60.0		
		0.02	176,400	64,300	42.8	61.0	60.0		
							51.0		
							48.0		
							71.0		
							53.0		
	avg	177,000	63,200	43.2	61.3	57.0	U	25	
76	0.02	245,300	69,000	37.1	56.9	87.0			
	0.02	240,600	65,500	37.0	55.2	93.5			
						83.0			
						91.0			
	avg	243,000	67,200	37.0	56.0	88.5	U	25	
20	0.02	297,400	---	32.9	36.8				
	0.02	298,400	82,700	33.0	38.0				
	0.02	296,600	82,500	---	---				
	avg	297,500	82,600	33.0	37.4				

TABLE V IRON ALLOYS (Continued)

MATERIAL	Test Temp °K	TENSILE PROPERTIES				IMPACT PROPERTIES			
		Crosshead Velocity	Tensile Strength	Yield Strength (0.2% offset)	Elongation	Reduction of Area	Energy Absorbed	Charpy Geometry	Fracture Area
		in/min	psi	psi	% in 4D	%	ft-lb		%
304 LC Annealed Specimen Type B	Room	0.02	98,300	56,700	79.2	83.7	65.0		
		0.02	98,400	57,000	78.6	83.0	65.5		
		avg	98,400	56,900	78.9	83.4	66.0	1/2 V	75
	195	0.02	153,500	61,100	71.8	76.8	102.0		
		0.02	152,500	62,100	67.6	76.7	82.0		
		avg	153,000	61,600	69.7	76.8	71.5	1/2 V	75
	76	0.02	222,300	66,900	42.3	69.6	80.5		
		0.02	221,400	65,700	43.6	68.9	74.5		
		avg	221,600	66,300	42.9	69.1	70.5	1/2 V	75
	20	0.02	272,900	75,400	47.8	38.6	63.0		
		0.02	273,300	75,800	36.7	42.1	74.5		
		avg	273,100	75,600	42.2	40.4	70.5	1/2 V	100
4	0.20	241,800	77,900	33.6	58.6	62.0			
	0.20	242,600	77,900	---	55.8				
	avg	242,200	77,900	33.6	57.2				
310 Annealed Specimen Type B	Room	0.02	84,900	31,800	62.1	70.2	70.0		
		0.02	84,200	31,700	56.3	72.2	71.0		
		avg	84,500	31,500	58.4	71.0	70.0	1/2 V	100
	195	0.02	106,700	43,500	69.8	67.7	66.0		
		0.02	107,300	44,300	73.3	68.4	71.0		
		avg	107,000	43,900	71.6	68.0	67.0	1/2 V	100
	76	0.02	157,700	76,500	68.8	46.2	51.0		
		0.02	156,600	75,600	66.6	53.0	55.0		
		avg	157,200	76,000	67.7	49.6	46.0	1/2 V	100
	20	0.005	181,100	99,300	41.9	34.8	48.5		
		0.02	185,000	100,200	46.8	38.5	44.5		
		avg	185,800	99,400	49.3	34.1	44.0	1/2 V	100
4	0.02	185,800	99,400	49.3	34.1	44.0			
	1.0	164,500	103,900	---	50.3				
	avg	179,100	100,700	46.0	39.4	45.5	1/2 V	100	
4	0.02	186,700	102,100	49.8	41.0				
	avg	186,700	102,100	49.8	41.0				

TABLE V IRON ALLOYS (Continued)

MATERIAL	Test Temp °K	TENSILE PROPERTIES				IMPACT PROPERTIES				
		Crosshead Velocity	Tensile Strength	Yield Strength (0.2% offset)	Elongation	Reduction of Area	Energy Absorbed	Charpy Geometry	Fracture Area	
		in/min	psi	psi	% in 4D	%	ft-lb		%	
410 Heat treated at 1800°F, 700°F temper Specimen Type B	Room	0.02	201,400	201,400	14.5	67.1	20.5			
		0.02	194,700	194,700	13.9	68.2	26.0			
		0.02	205,700	205,700	14.6	66.2	16.5			
			avg	200,600	200,600	14.3	67.2	34.0		
							21.0			
							21.5			
							17.0			
							22.5	V	100	
		195	0.02	216,400	216,400	15.6	63.7	6.0		
	0.02		205,800	205,800	15.8	66.3	8.0			
	0.02		214,300	214,300	13.8	63.2	12.0			
			avg	212,200	212,200	15.1	64.4	6.5		
						13.0				
						9.5				
						11.0				
						9.0				
						12.0				
		avg	264,100	264,100	5.8	20.6	9.5	V	100	
	76	0.02	258,900	258,900	6.2	20.6	3.0			
0.02		269,300	269,300	5.4	20.7	2.0				
			avg	264,100	264,100	5.8	20.6	2.0		
						3.0				
						2.0				
						2.0				
	20	0.02	327,600	---	0.7	6.0				
0.02		315,900	---	0.8	5.2					
			avg	321,800	---	0.8	5.6			
	Room	0.02	205,600	165,600	15.6	53.9	33.5			
0.02		201,300	179,100	14.9	53.8	33.5				
0.02		202,500	177,500	14.9	52.2	34.0				
			avg	203,100	174,100	15.1	53.3	33.5	V	
						100				
	195	0.02	217,300	182,300	15.5	51.6	10.0			
0.02		218,900	182,900	15.3	52.5	9.5				
			avg	218,100	182,600	15.4	52.0	10.0		
						10.0				
						10.0	V	100		
	76	0.02	258,300	230,200	8.4	18.8	2.0			
0.02		262,300	233,400	11.1	29.8	2.5				
0.02		260,700*	---	---	27.1*	3.0				
0.02		263,000	---	8.2	18.2	2.5				
			avg	261,100	231,800	9.2	23.5	2.5	V	
						100				
	20	0.02	290,100	290,100	0.4	2.1				
0.02		295,100	295,100	---	2.5					
			avg	292,600	292,600	0.4	2.3			

TABLE VI NICKEL ALLOYS

MATERIAL	Test Temp °K	TENSILE PROPERTIES				IMPACT PROPERTIES			
		Crosshead Velocity	Tensile Strength	Yield Strength (0.2% offset)	Elongation	Reduction of Area	Energy Absorbed	Charpy Geometry	Fracture Area
		in/min	psi	psi	% in 4D	%	ft-lb		%
INCONEL Cold drawn 20% Specimen Type A	Room	0.02	131,900	124,200	17.2	58.8	62.0		
		0.02	130,600	122,700	16.8	56.9	80.5		
							72.5		
		avg	131,200	123,400	17.0	57.9	84.0	V	75
	195	0.02	143,700	133,600	19.7	57.8	88.5		
		0.02	142,800	130,400	20.5	58.9	91.0		
							89.0		
		avg	143,300	132,000	20.1	58.4	89.5	V	100
	76	0.02	167,700	150,500	26.2	62.1	77.0		
		0.02	168,900	---	26.6	61.7	86.0		
							85.0		
		avg	168,300	150,500	26.4	61.9	82.5	V	100
20	0.02	180,400	160,000	30.4	55.5				
	0.02	181,700	160,700	30.6	55.9				
	avg	181,100	160,400	30.5	55.7				
INCONEL "X" Direct aged 1300°F, AC, tempered Specimen Type B	Room	0.02	191,600	136,300	24.1	47.5	40.5		
		0.02	191,900	136,300	26.5	46.6	40.0		
		0.02	188,600	136,900	25.6	44.6	40.0		
		avg	190,900	136,600	25.9	46.6	40.0	V	100
	195	0.02	204,900	143,500	30.1	49.1			
		0.02	203,100	143,700	30.0	47.4			
		avg	204,000	143,600	30.0	48.3			
	76	0.02	227,500	151,300	31.7	45.6	35.0		
		0.02	226,500	---	32.4	45.7	34.5		
		0.02	226,500	150,200	32.9	45.4	35.0		
		avg	227,200	150,600	32.6	45.3	35.0	V	100
20	0.02	248,500	156,100	33.3	43.6				
	0.02	247,200	155,300	34.0	40.0				
	0.02	241,000	155,400	34.7	43.3				
	avg	243,600	153,800	35.6	42.2				
	avg	245,100	155,200	34.4	42.3				

TABLE VI NICKEL ALLOYS (Continued)

MATERIAL	Test Temp °K	TENSILE PROPERTIES				IMPACT PROPERTIES				
		Crosshead Velocity	Tensile Strength	Yield Strength (0.2% offset)	Elongation	Reduction of Area	Energy Absorbed	Charpy Geometry	Fracture Area	
		in/min	psi	psi	% in 4D	%	ft-lb		%	
"A" NICKEL Annealed Specimen Type A	Room	0.02	62,700	---	---	---	89.5			
		0.02	64,000	21,400	49.1	66.2	94.5			
		0.02	64,300	20,400	47.8	66.2	94.5			
		avg	63,700	20,900	48.4	66.2	93.0	1/2 V	50	
	195	0.02	71,100	21,100	51.4	69.2	79.0			
		0.02	69,900	22,200	48.8	64.1	92.5			
		0.02	71,300	22,800	50.6	63.5	88.0			
		avg	70,800	22,000	50.3	65.6	84.5	1/2 V	50	
	76	0.02	93,200	28,400	62.1	76.2	86.5			
		0.02	92,200	28,000	60.8	75.1	90.0			
		0.02	93,600	29,000	60.7	74.3	87.0			
		avg	93,000	28,500	61.2	75.2	81.0	1/2 V	75	
	20	0.02	112,400	37,300	59.2	68.2	99.5			
		0.02	111,400	39,600	59.1	67.5	93.5			
							100.5			
		avg	111,900	38,400	59.2	67.8	98.0	1/2 V	75	
	RENE 41 (R41) Solution treated at 1975°F, WQ Specimen Type B	Room	0.02	192,300	138,000	28.9	32.3	15.0		
			0.02	191,900	---	24.6	33.0	15.5		
			0.02	191,000	140,300	25.2	33.2	14.5		
			avg	191,700	139,200	26.2	32.8	15.0	1/2 V	100
		195	0.02	207,600	---	---	---	13.0		
			0.02	197,100	140,000	30.3	34.8	12.0		
			0.02	202,400	143,800	28.9	33.1	13.5		
			avg	202,400	141,900	29.6	34.0	12.5	1/2 V	100
76		0.02	238,900	162,200	27.7	24.6	11.5			
		0.02	240,500	164,400	29.3	26.6	10.5			
							10.5			
		avg	239,700	163,300	28.5	25.6	10.5	1/2 V	100	
20		0.02	254,000	---	27.4	26.6	11.5			
		0.02	254,200	172,900	24.9	24.3	10.0			
							11.5			
		avg	254,100	172,900	26.2	25.4	11.0	1/2 V	100	

TABLE VI NICKEL ALLOYS (Continued)

MATERIAL	Test Temp °K	TENSILE PROPERTIES				IMPACT PROPERTIES			
		Crosshead Velocity	Tensile Strength	Yield Strength (0.2% offset)	Elongation	Reduction of Area	Energy Absorbed	Charpy Geometry	Fracture Area
		in/min	psi	psi	% in 4D	%	ft-lb		%
"K" MONEL Age hardened at 1100°F and 1000°F, AC Specimen Type B	Room	0.02	169,100	118,700	26.6	51.6	35.0		
		0.02	170,900	119,700	27.6	53.7	41.5		
							32.0		
							41.5		
							34.0		
		avg	170,000	119,200	27.1	52.6	37.0	V	100
	195	0.02	178,100	128,700	30.3	54.2	37.5		
		0.02	179,000	130,900	28.3	54.5	37.5		
		0.02	176,100	129,000	27.3	54.3	30.5		
							28.0		
							36.5		
		avg	177,700	129,500	28.6	54.3	34.0	V	100
76	0.02	199,500	142,900	33.4	54.3	30.5			
	0.02	196,100	142,700	33.2	54.3	36.5			
						28.5			
						28.5			
	avg	197,800	142,800	33.3	54.3	31.0	V	100	
20	0.02	212,300	152,900	34.3	52.6				
	0.02	214,400	152,000	33.8	52.1				
	avg	213,400	152,400	34.0	52.4				
"S" MONEL Cast, annealed 1600°F, 1300°F, OQ Specimen Type A	Room	0.02	115,100	78,600	---	36.0	26.0		
		0.02	102,800	74,100	4.5	28.0	54.5		
		0.02	111,600	---	9.0	27.4	39.5		
							46.5		
							39.5		
		avg	109,800	76,400	6.8	30.5	41.0	V	100
	195	0.02	117,100	83,700	12.5	26.0	43.5		
		0.02	126,700	---	9.3	21.6	37.0		
		0.02	126,800	86,200	17.0	32.0	53.0		
							41.5		
		avg	123,500	85,000	12.9	26.5	43.5	V	100
	76	0.02	127,800	97,100	18.5	32.8	30.0		
0.02		137,200	97,200	---	17.4	43.0			
0.02		135,700	---	12.7	18.0	43.5			
	avg	133,600	97,200	15.6	22.7	39.0	V	100	
20	0.02	135,400	106,500	17.4	28.1				
	0.02	145,100	---	---	23.4				
	0.02	168,500	---	12.4	20.8				
	avg	149,700	106,500	14.9	24.1				

TABLE VII TITANIUM ALLOYS

MATERIAL	Test Temp °K	TENSILE PROPERTIES				IMPACT PROPERTIES				
		Crosshead Velocity	Tensile Strength	Yield Strength (0.2% offset)	Elongation	Reduction of Area	Energy Absorbed	Charpy Geometry	Fracture Area	
		in/min	psi	psi	% in 4D	%	ft-lb		%	
5Al-2.5Sn, (A-110AT) Annealed Specimen Type B	Room	0.02	135,200	127,800	17.4	42.4	17.5			
		0.02	133,000	126,000	20.5	44.7	17.5			
		avg	134,100	126,900	19.0	43.6	17.5	V	100	
	195	0.02	159,700	150,400	13.2	37.5	14.5			
		0.02	160,500	150,600	14.0	39.5	15.0			
		avg	160,100	150,500	13.6	38.5	13.5	V	100	
	76	0.02	208,100	200,000	13.5	29.2	11.5			
		0.02	208,800	200,300	14.2	29.8	11.5			
		avg	208,400	200,200	13.8	29.5	10.5	V	100	
		20	0.02	250,900	242,900	10.7	17.2			
			0.02	250,800	242,200	12.3	19.4			
			avg	250,800	242,600	11.5	18.3			
13V-11Cr-3Al (B-120 VCA) Solution treated Specimen Type B	Room	0.02	136,900	136,900	27.4	56.2	20.0			
		0.02	137,400	137,600	25.6	55.6	18.5			
		avg	137,200	137,200	26.5	55.9	20.5	V	100	
	195	0.02	182,800	181,900	17.3	48.0	11.5			
		0.02	183,900	183,900	16.1	46.0	9.5			
		avg	183,400	182,900	16.7	47.0	9.5	V	100	
	76	0.02	279,400	273,200	6.1	20.5	4.0			
		0.02	279,600	273,500	7.3	21.4	5.0			
		avg	279,500	273,400	6.7	21.0	2.5	V	100	
		20	0.02	327,100	---	0.3	2.5			
			0.02	338,900	---	0.6	4.4			
			avg	333,000		0.4	3.4			
6Al-4V (C-120 AV) Annealed Specimen Type B	Room	0.02	147,900	138,000	17.0	48.4	28.5			
		0.02	149,100	138,000	16.1	46.3	28.0			
		avg	148,500	138,000	16.6	47.4	26.0	V	100	
	195	0.02	173,500	163,900	12.5	41.5	22.5			
		0.02	174,300	164,400	13.3	41.6	22.0			
		avg	173,900	164,200	12.9	41.6	22.5	V	100	
	76	0.02	236,800	227,200	10.0	40.7	14.5			
		0.02	239,500	230,000	10.4	40.5	16.0			
		avg	238,200	228,600	10.2	40.6	16.5	V	100	
		20	0.02	285,900	277,200	6.7	32.3			
			0.02	286,400	278,400	6.7	29.8			
			avg	286,200	277,800	6.7	31.0			

FIGURE 1 HIGH-ELONGATION EXTENSOMETER

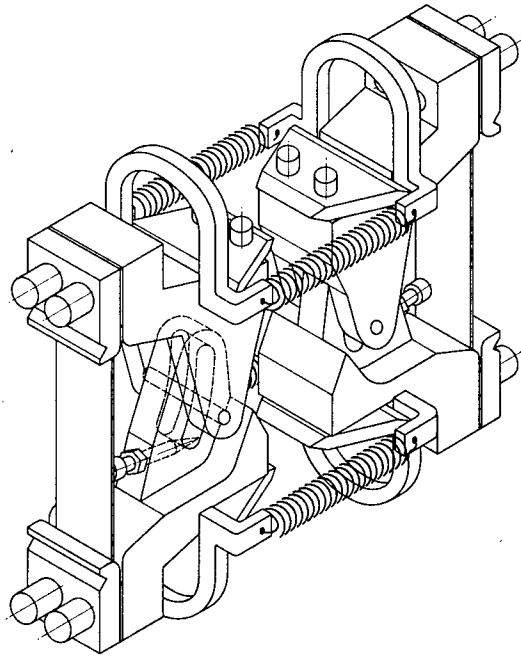

FIGURE 2 TEST SPECIMEN CONFIGURATION

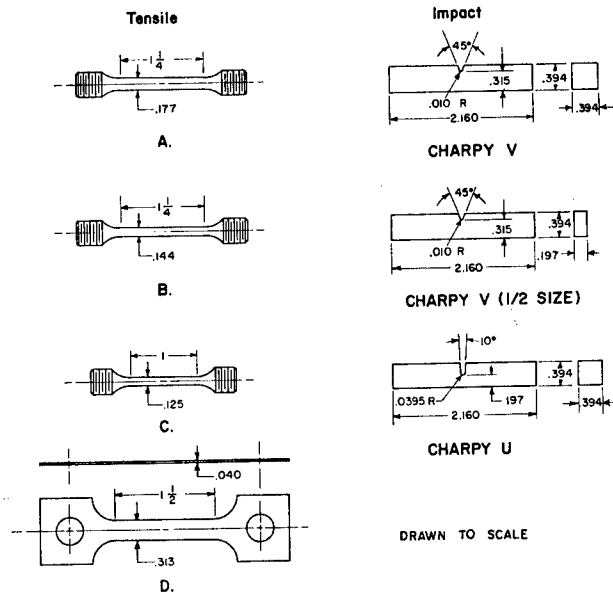
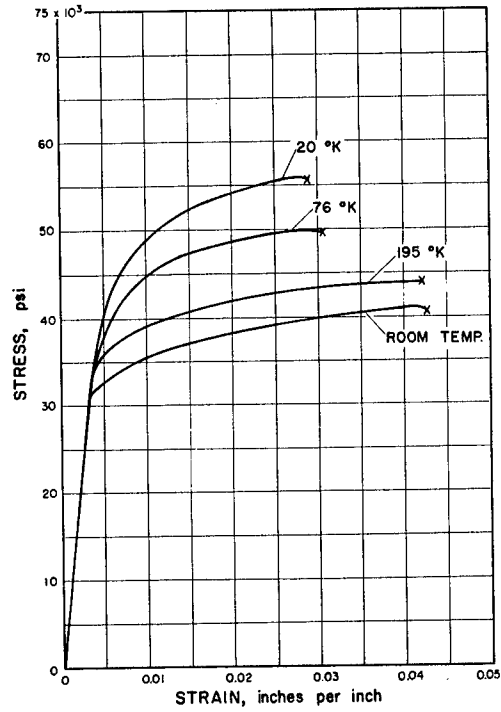
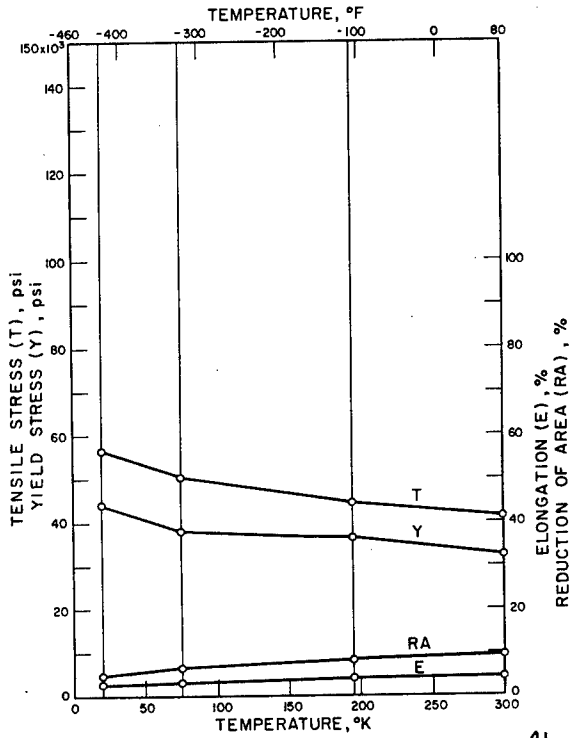
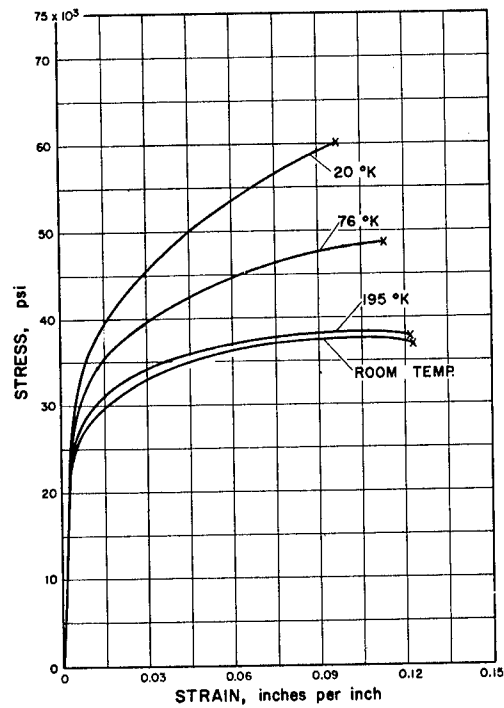
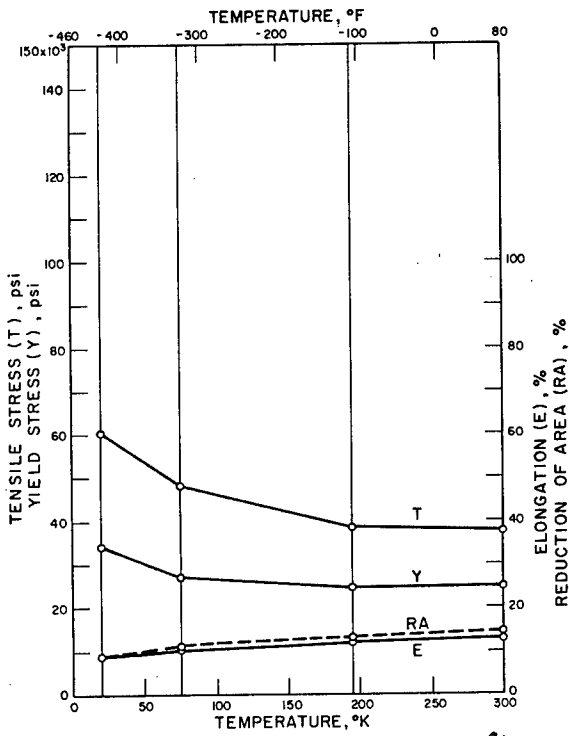

FIGURE 3. TENSILE PROPERTIES OF THE ALUMINUM ALLOYS.



AI
TENS 50, SAND CAST T 6



AI
356, CHILL CAST T 6

FIGURE 4. TENSILE PROPERTIES OF THE ALUMINUM ALLOYS.

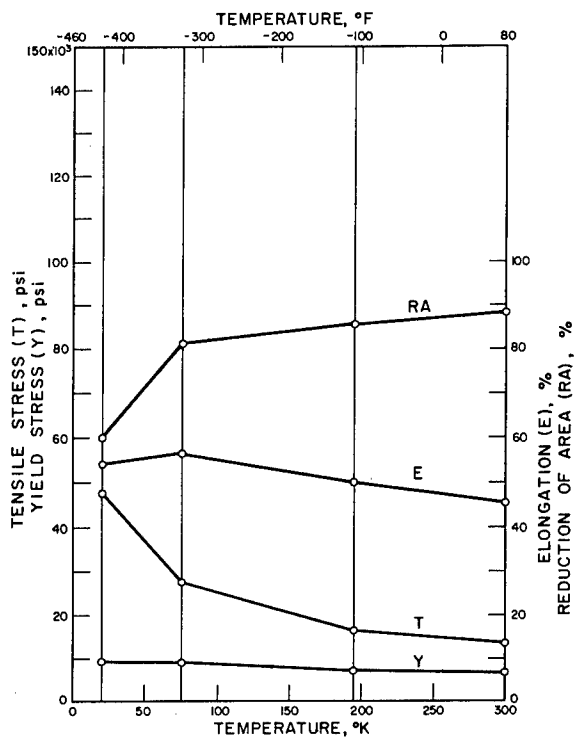

Al 1100, 0

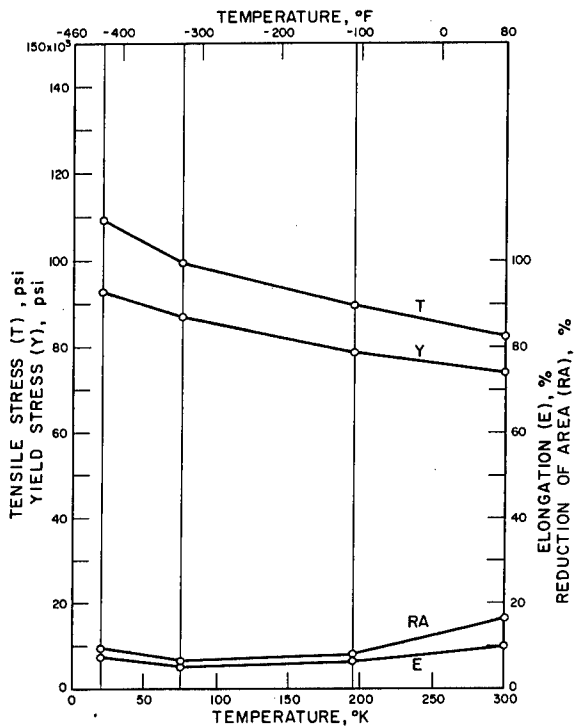
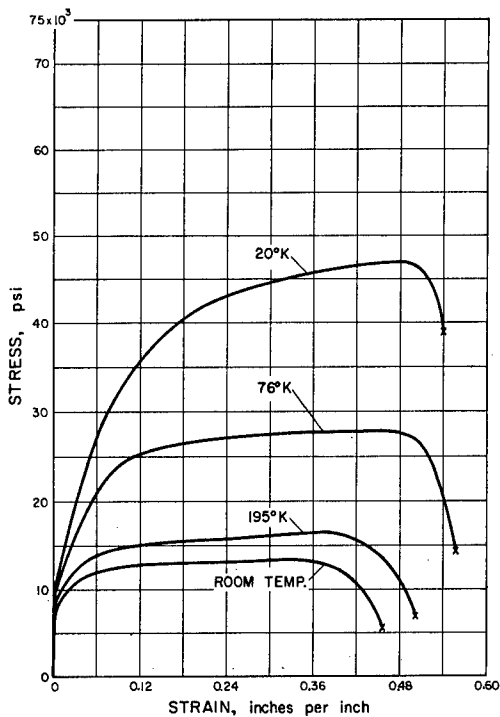

Al 2020, T6

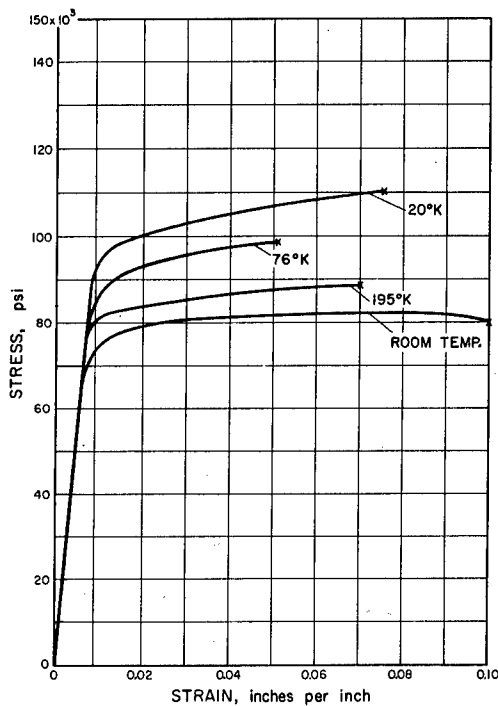
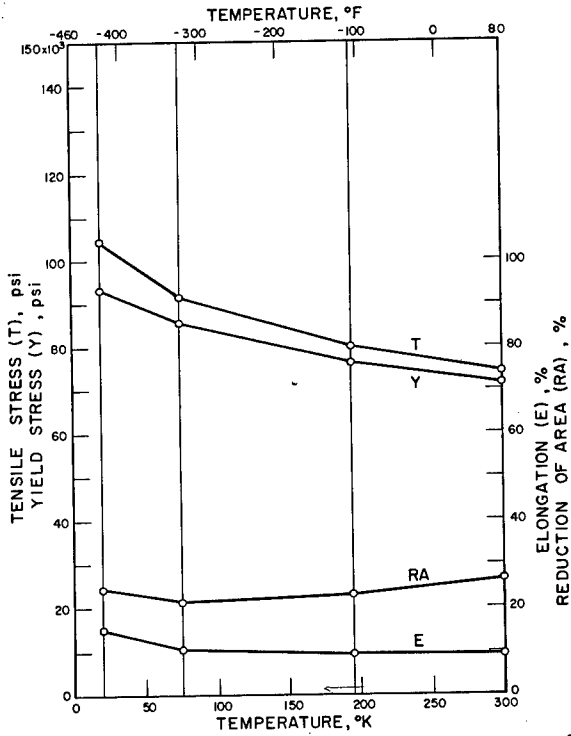
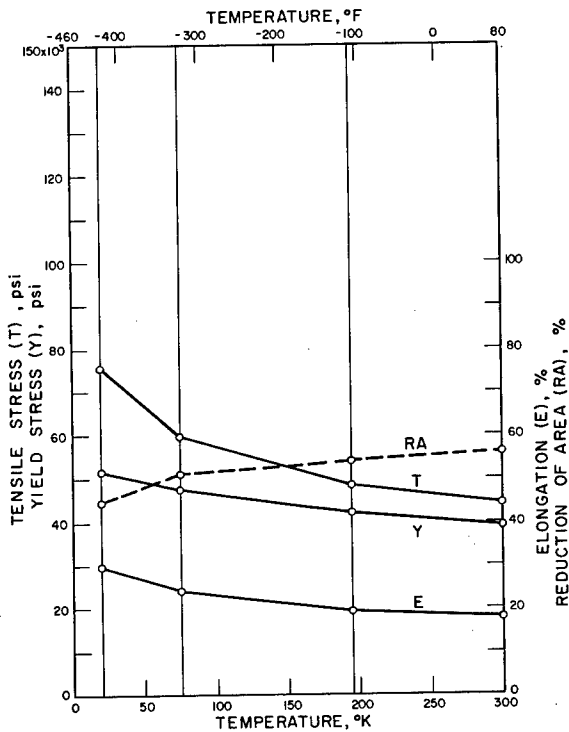
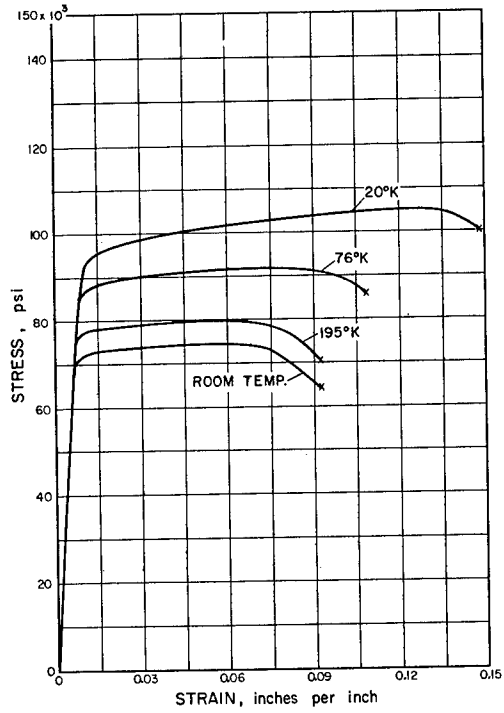

FIGURE 5. TENSILE PROPERTIES OF THE ALUMINUM ALLOYS.



2024 Al, T86



6061 Al, T6

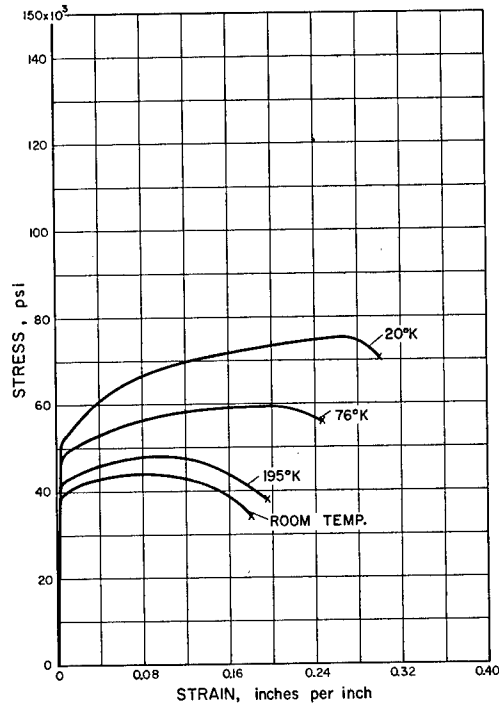

FIGURE 6. TENSILE PROPERTIES OF THE ALUMINUM ALLOYS.

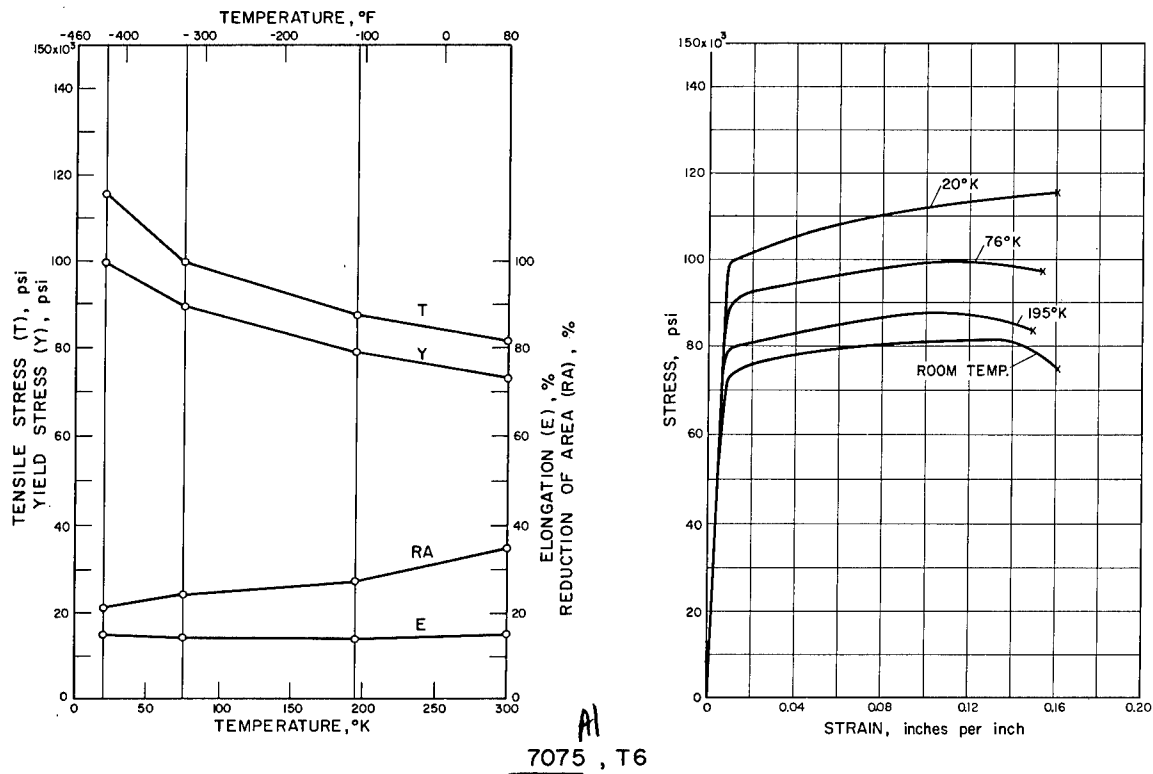

FIGURE 7. IMPACT PROPERTIES OF THE ALUMINUM ALLOYS.

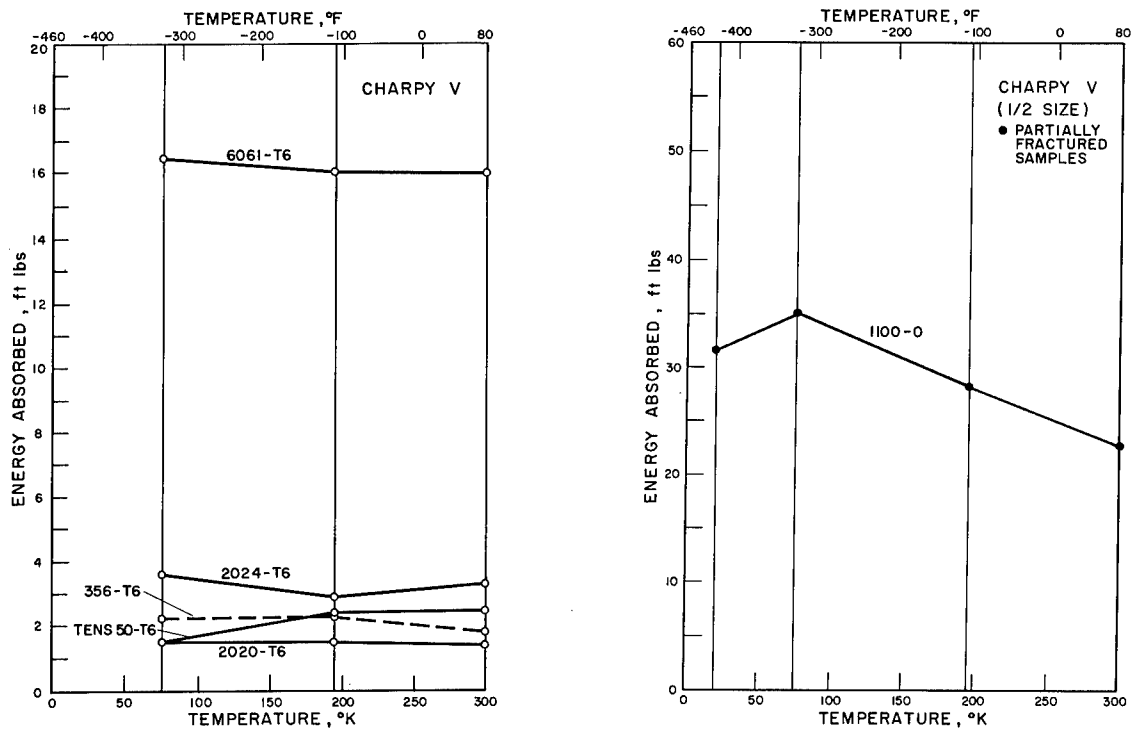
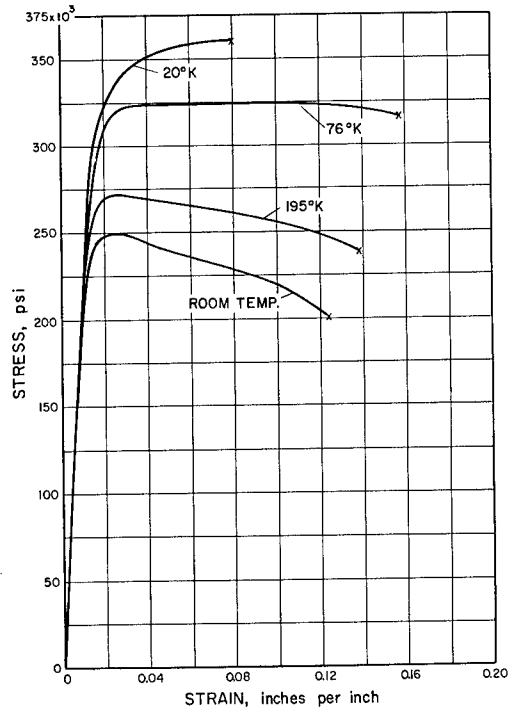
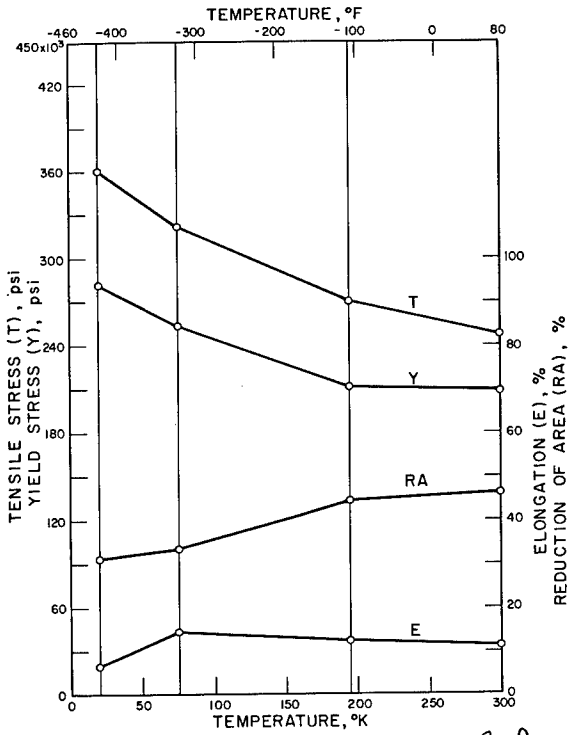

FIGURE 8. TENSILE PROPERTIES OF THE COBALT ALLOYS.



CoB
ELGILOY, COLD REDUCED 45%

FIGURE 9. IMPACT PROPERTIES OF THE COBALT ALLOYS.

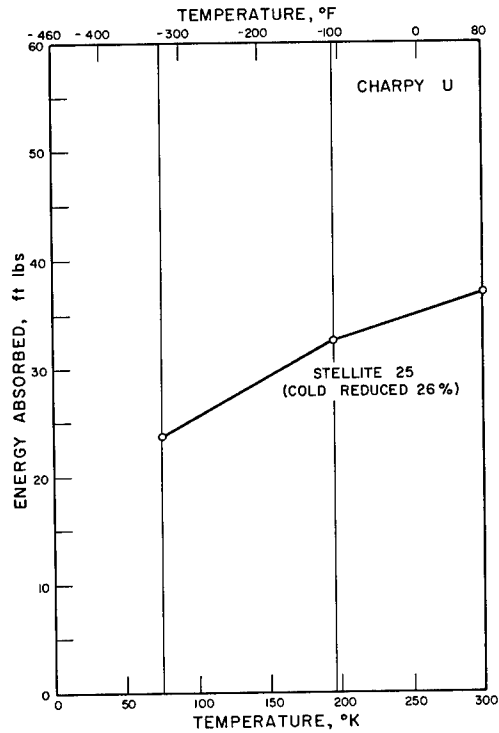
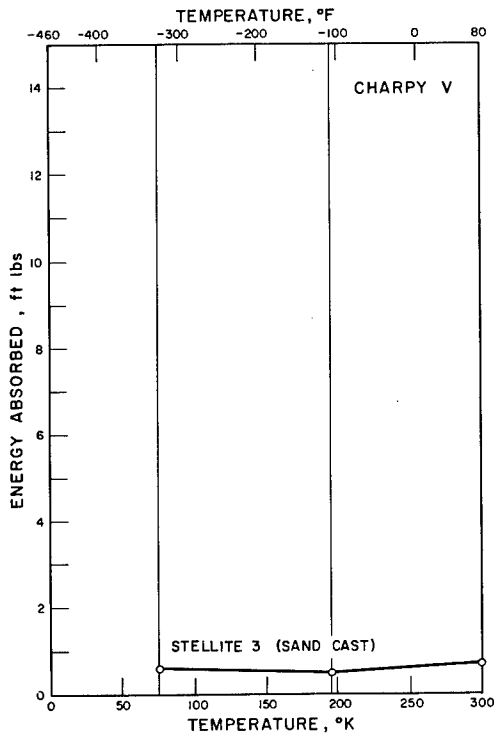
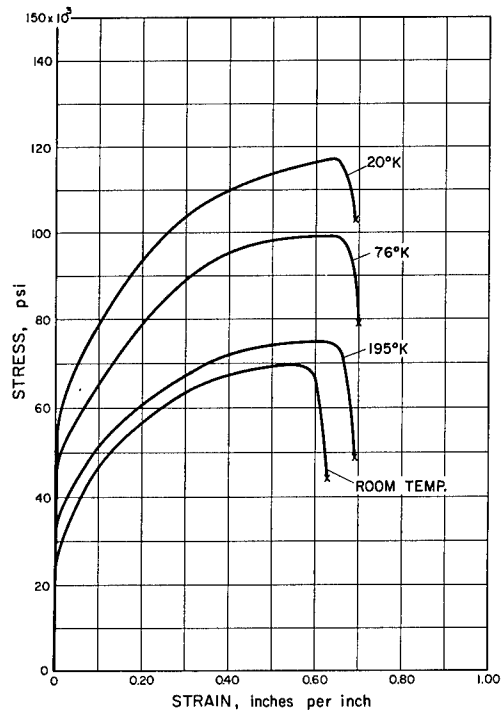
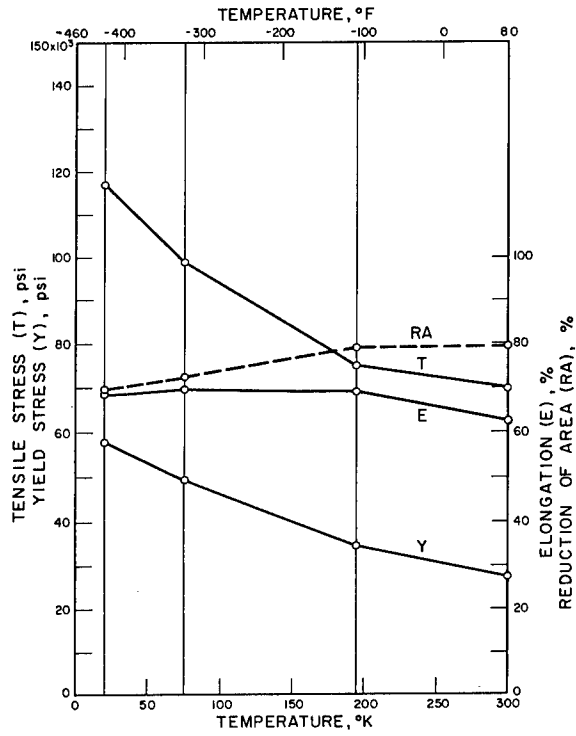
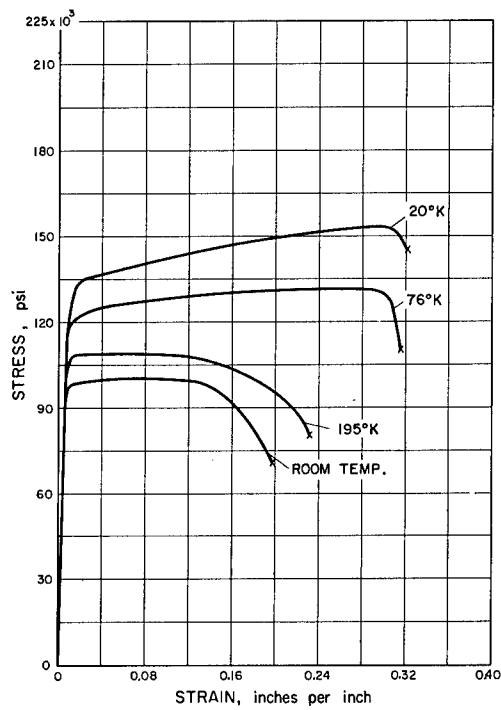
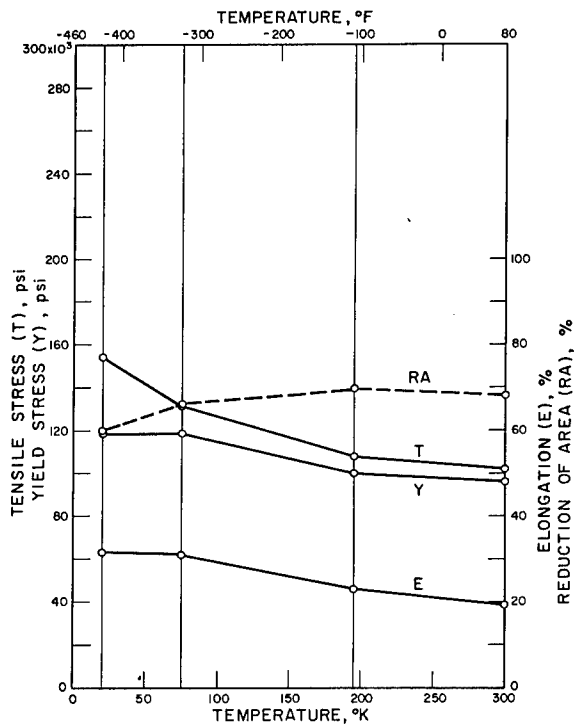

FIGURE 10. TENSILE PROPERTIES OF THE COPPER ALLOYS.



BERYLCO 25 , ANNEALED



BERYLCO 25 , HARD

FIGURE II. TENSILE PROPERTIES OF THE COPPER ALLOYS.

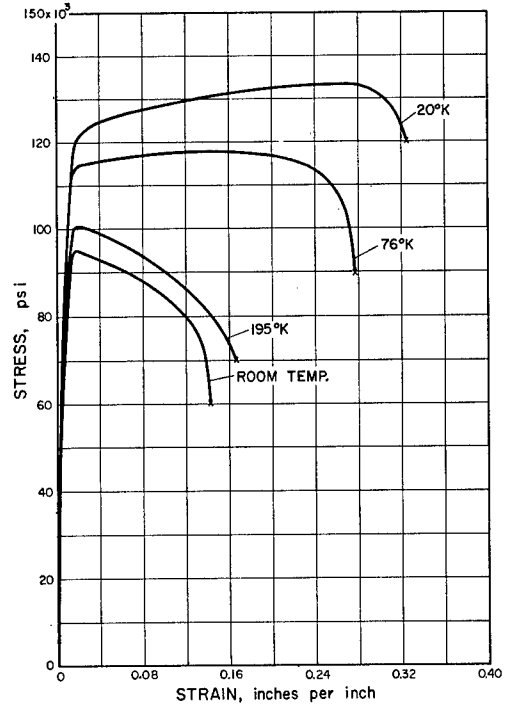
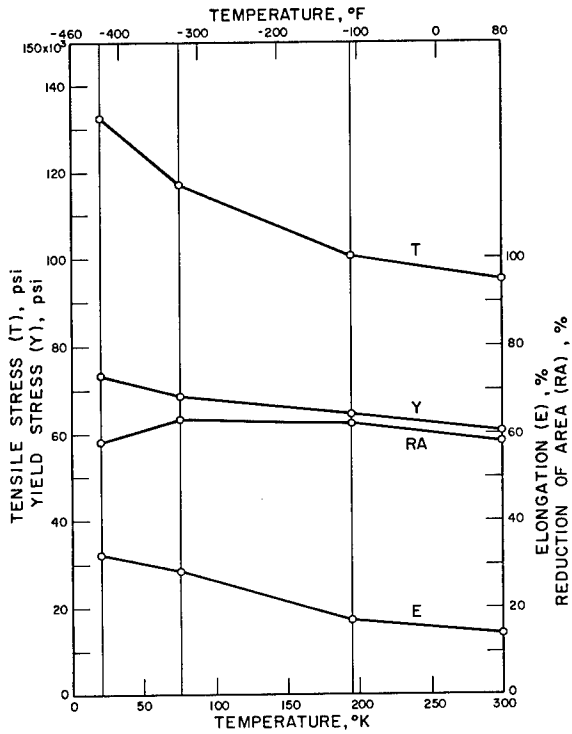

70/30 BRASS , 3/4 HARD

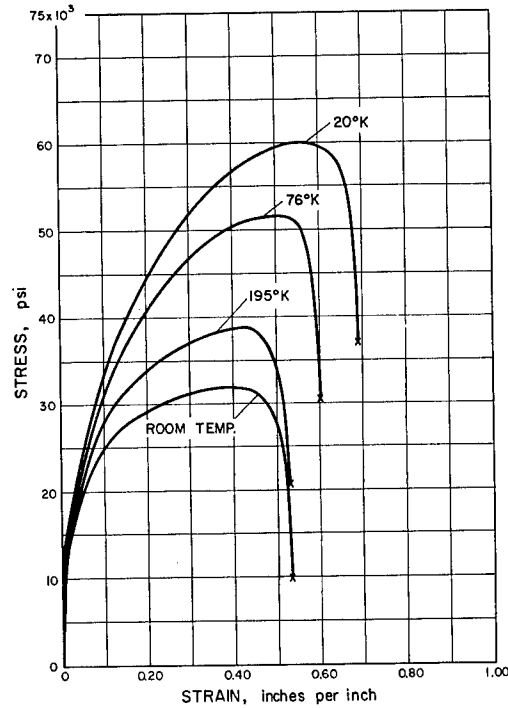
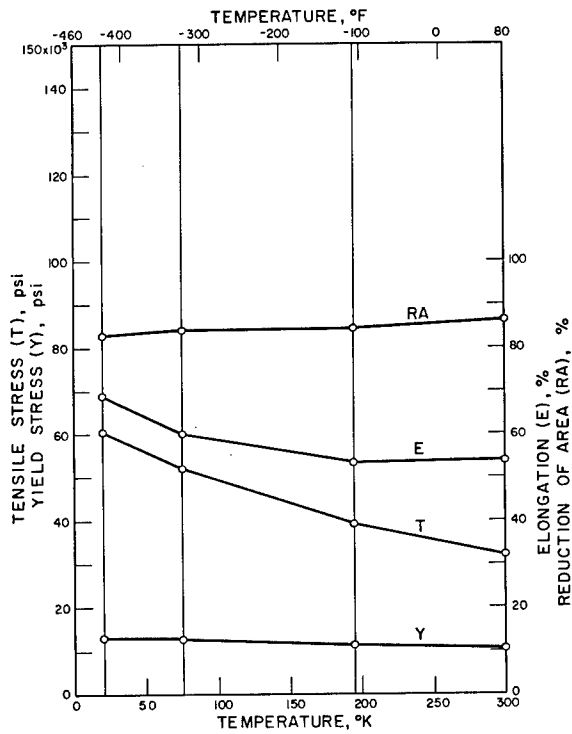

OFHC , SOFT

FIGURE 12. IMPACT PROPERTIES OF THE COPPER ALLOYS.

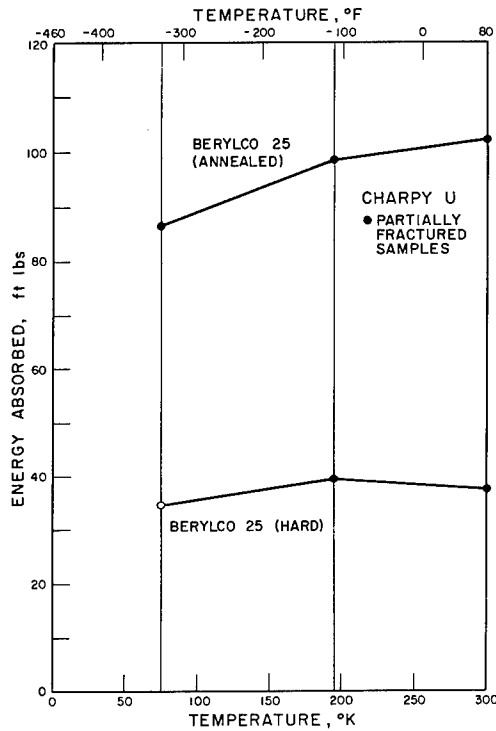
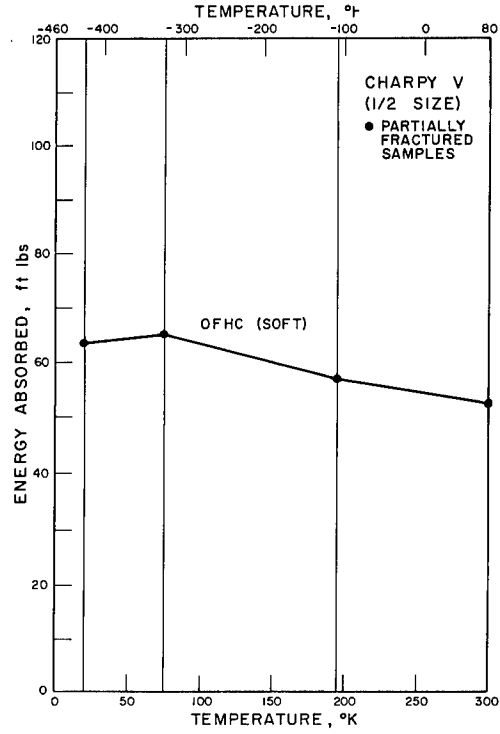
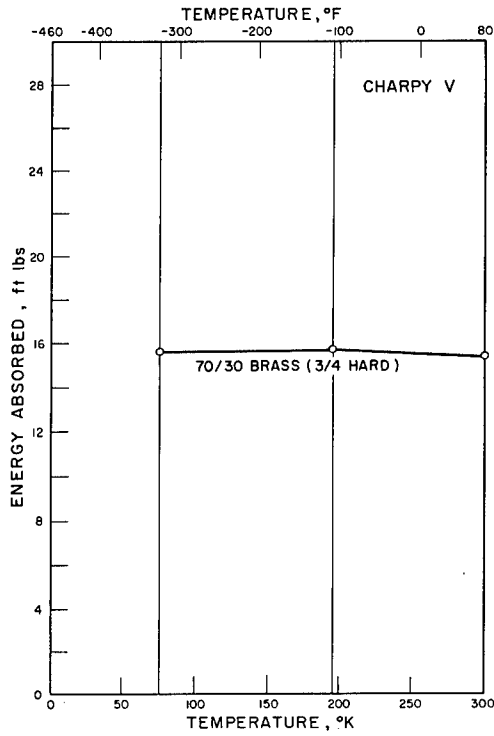
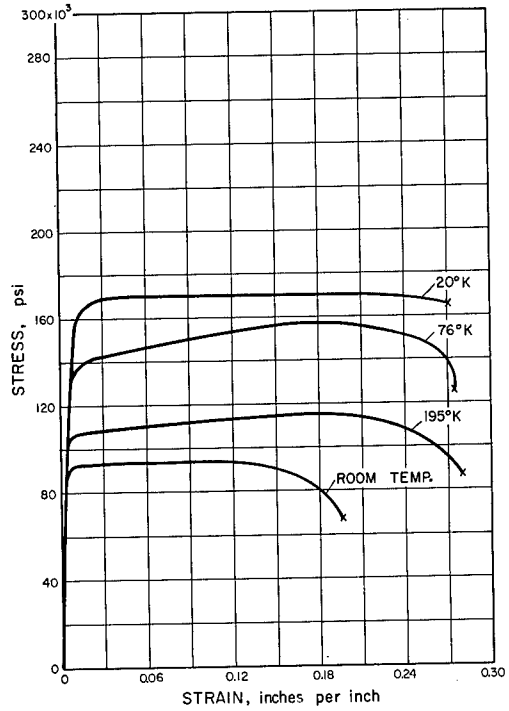
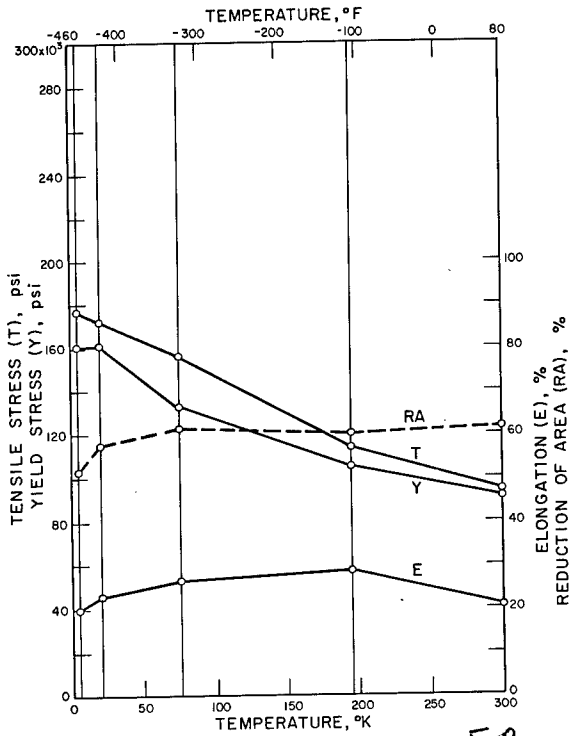
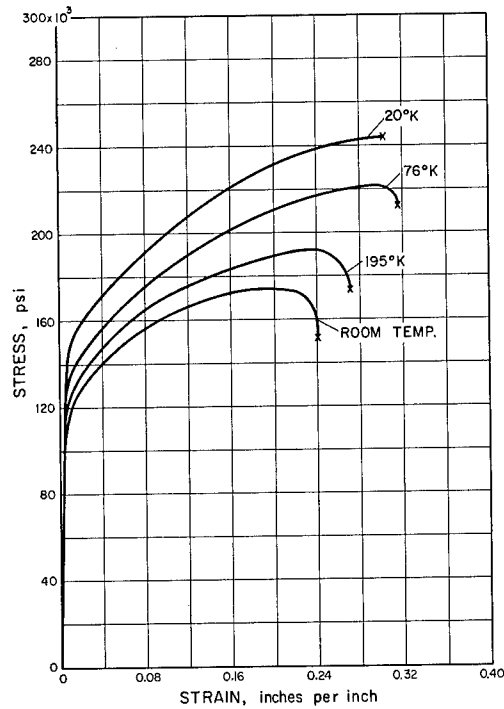
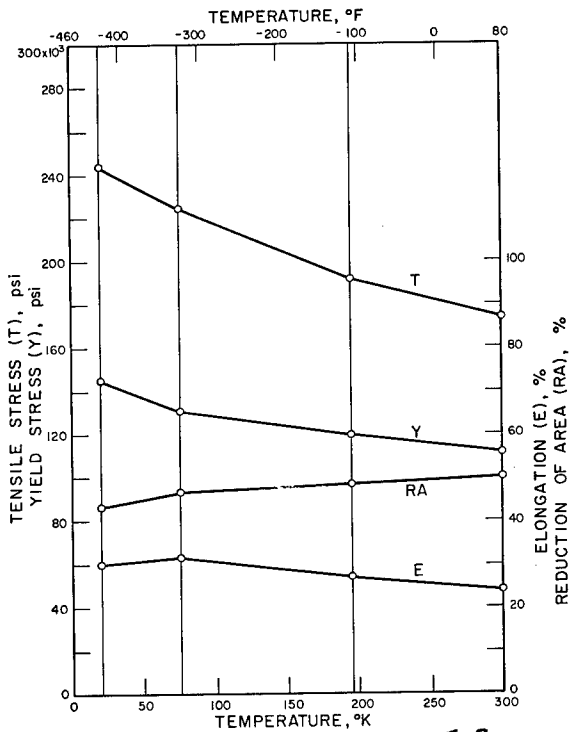

FIGURE 13. TENSILE PROPERTIES OF THE IRON ALLOYS.



FeB
INVAR 36, 12-15% COLD DRAWN



FeB
NISPAN "C", AGE HARDENED 1200°F - 5 HR, AC, TEMPERED

TABLE VIII

MATERIAL	Test Temp °K	TENSILE PROPERTIES					IMPACT PROPERTIES		
		Crosshead Velocity	Tensile Strength	Yield Strength (0.2% offset)	Elongation	Reduction of Area	Energy Absorbed	Charpy Geometry	Fracture Area
		in/min	psi	psi	% in 4D	%	ft-lb		%
<u>TITANIUM CARBIDE</u> RF Sintered (32% Ni)	Room						.30		
							.25		
							.25		
		avg					.25	V	100
	195						.20		
							.20		
							.20		
		avg					.20	V	100
	76						.20		
							.20		
							.20		
		avg					.20	V	100
<u>TUNGSTEN CARBIDE</u> RF (CA-10) Sintered (13% Co)	Room						1.0		
							1.0		
							1.0		
		avg					1.0	V	100
	195						1.0		
							1.0		
							1.0		
		avg					1.0	V	100
	76						1.0		
							1.0		
							1.0		
		avg					1.0	V	100

FIGURE 14. TENSILE PROPERTIES OF THE IRON ALLOYS.

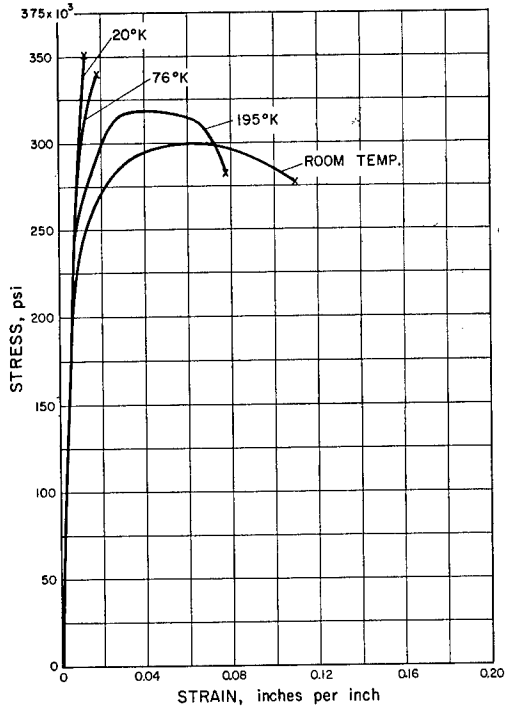
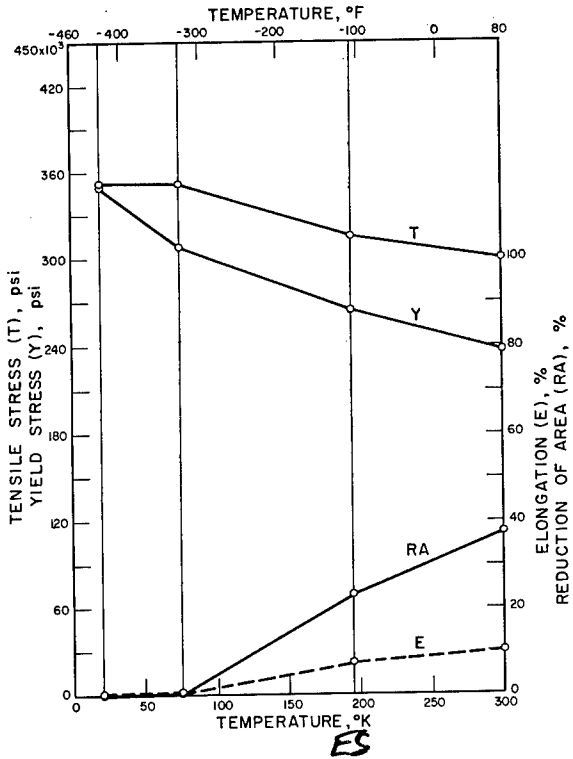

UNIMACH #1 (VASCOJET 1000), HEAT TREATED 1850 °F - 1 HR, AC, DOUBLE TEMPERED 1025 °F - 3/4 HR

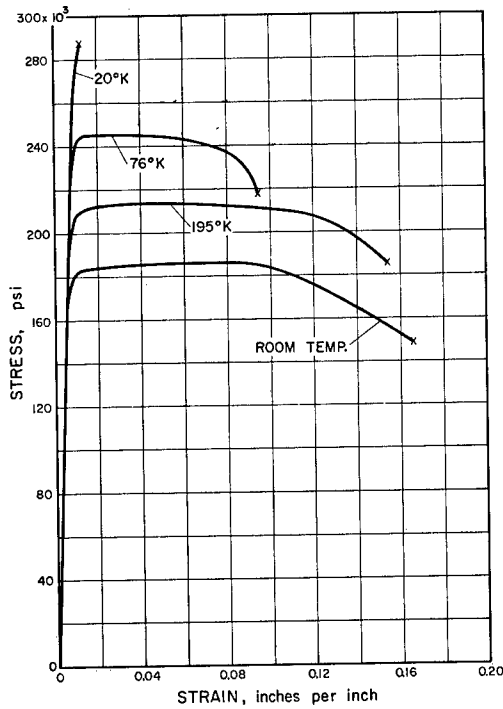
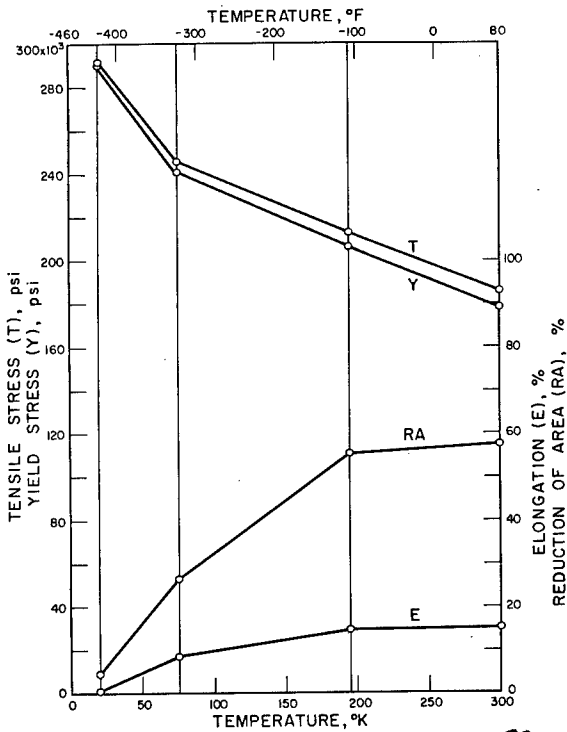

SS
17-4 PH, H 1100

FIGURE 15. TENSILE PROPERTIES OF THE IRON ALLOYS.

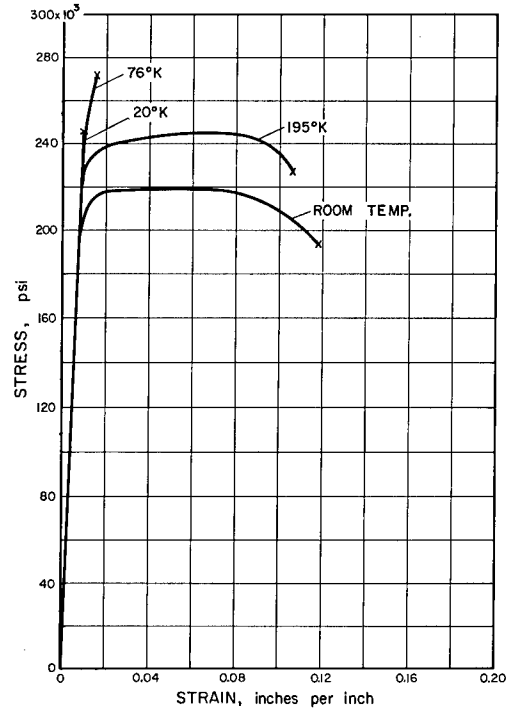
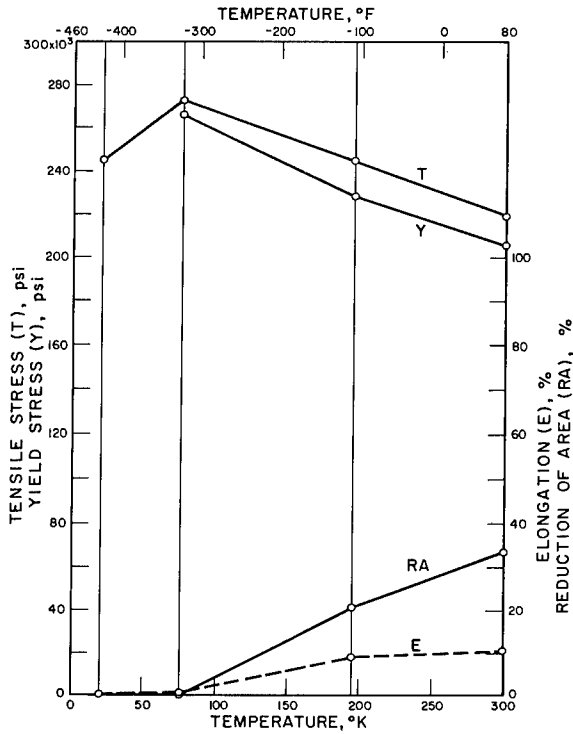

SS
17-7 PH, TH 1050

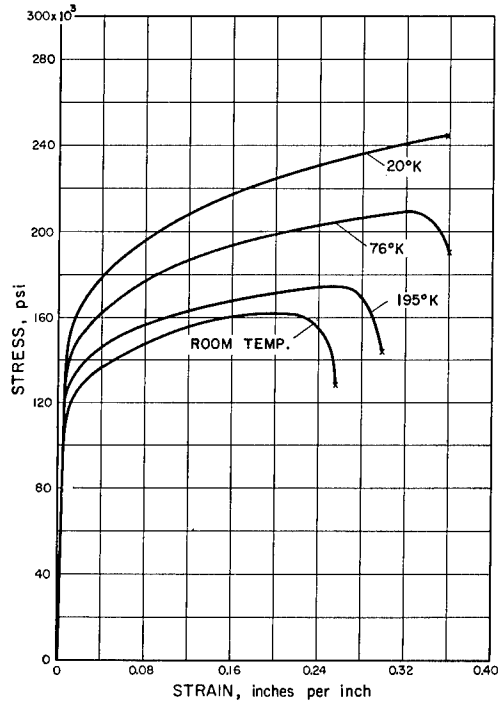
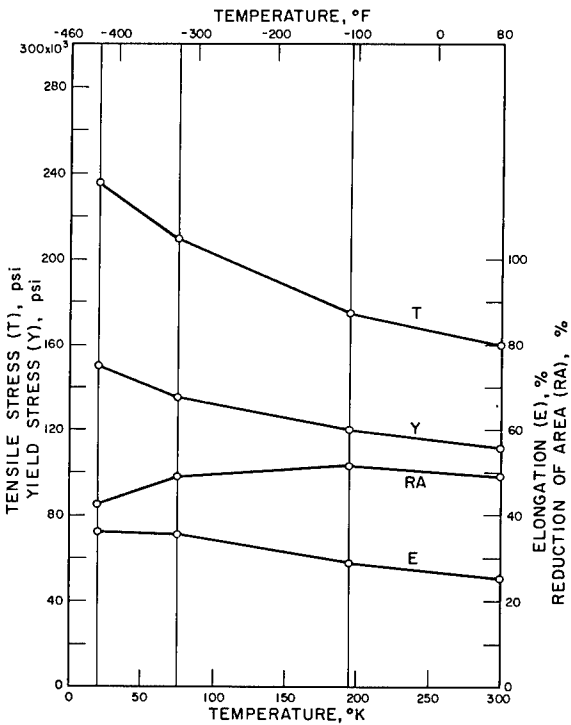

SS
A-286, SOLUTION TREATED 1800°F - 1 1/2 HR, AC, AGED AT 1350 °F - 16HR, AC

FIGURE 16. TENSILE PROPERTIES OF THE IRON ALLOYS.

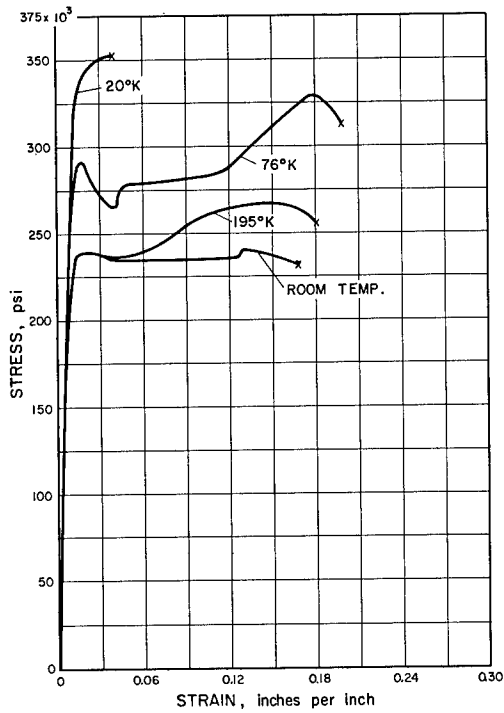
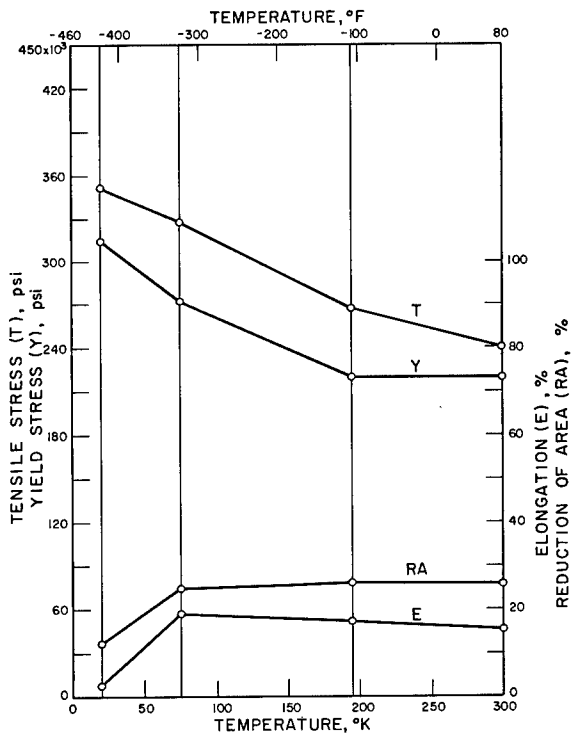

SS
301, EXTRA FULL HARD

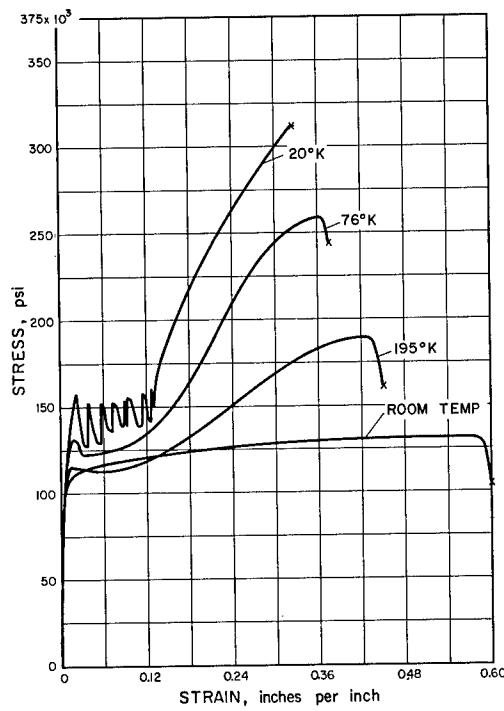
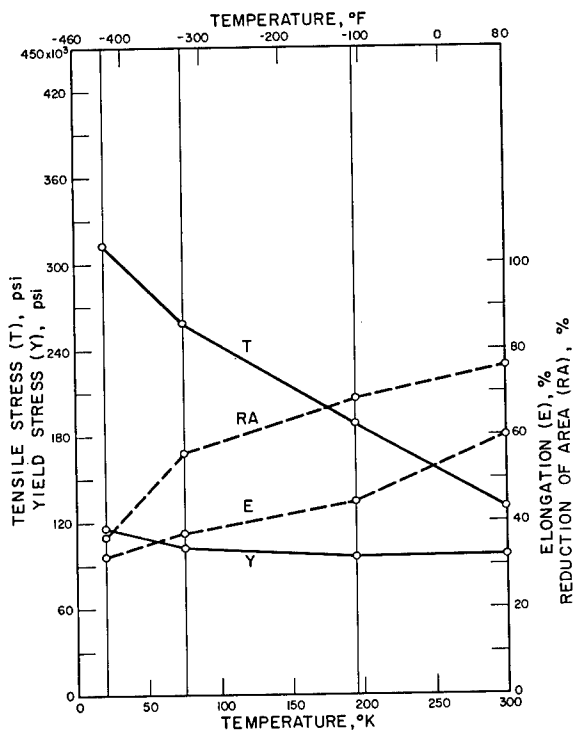

SS
302, COLD DRAWN

FIGURE 17. TENSILE PROPERTIES OF THE IRON ALLOYS.

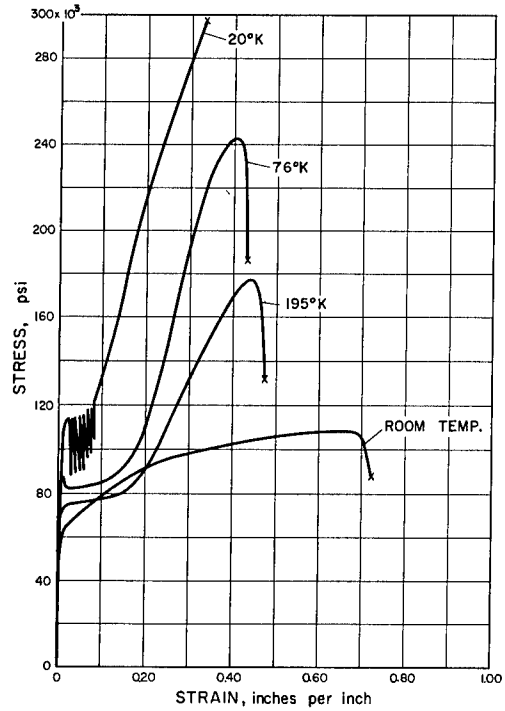
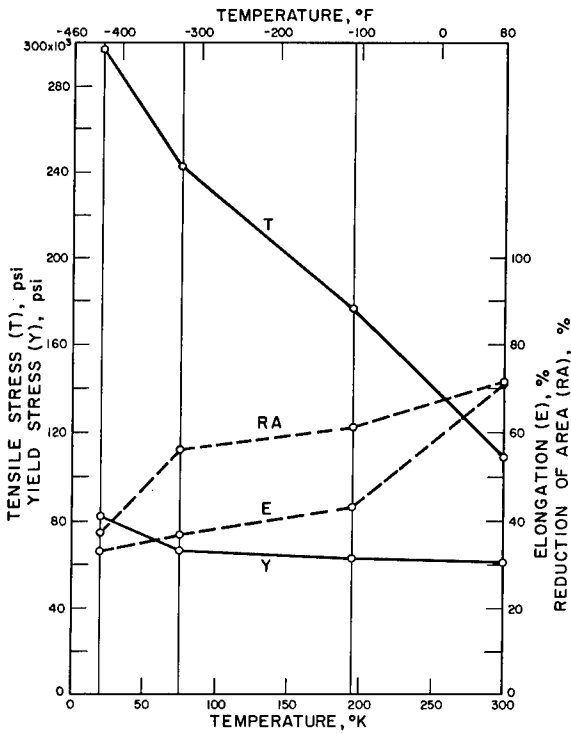

SS
303, ANNEALED

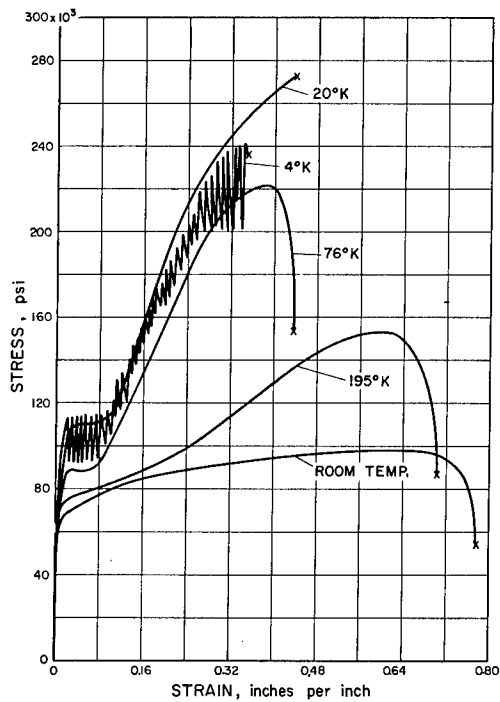
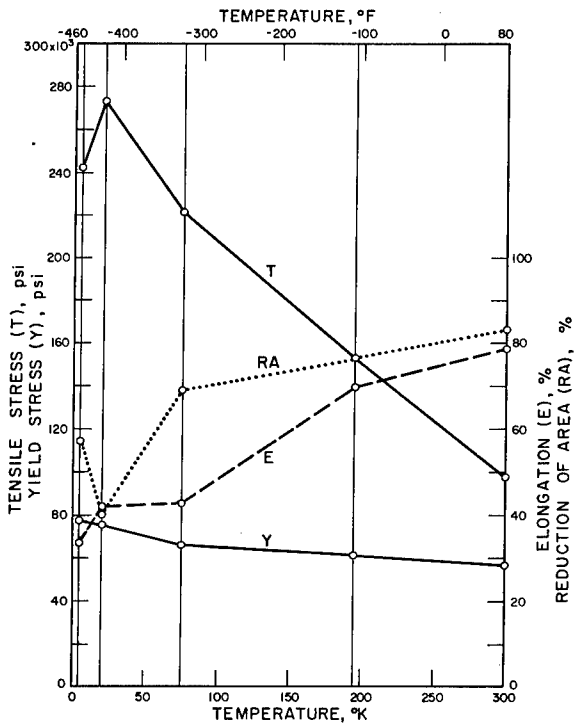

SS
304 L, ANNEALED

FIGURE 18. TENSILE PROPERTIES OF THE IRON ALLOYS.

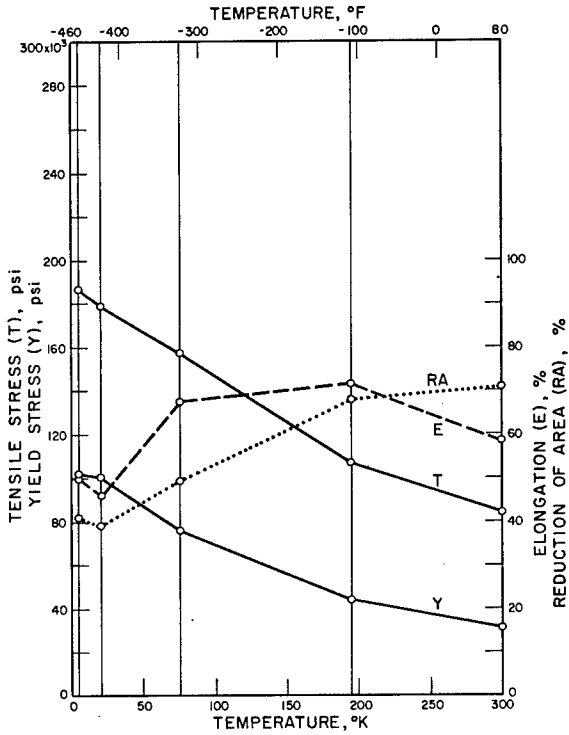

SS
310, ANNEALED

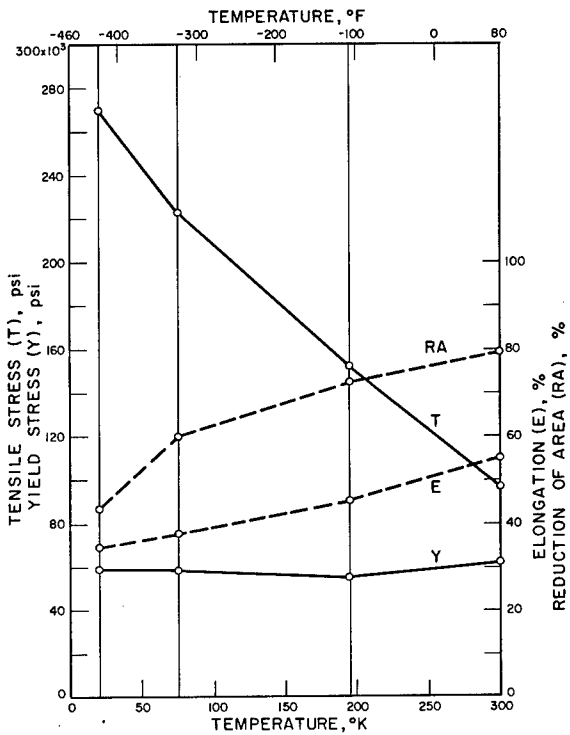
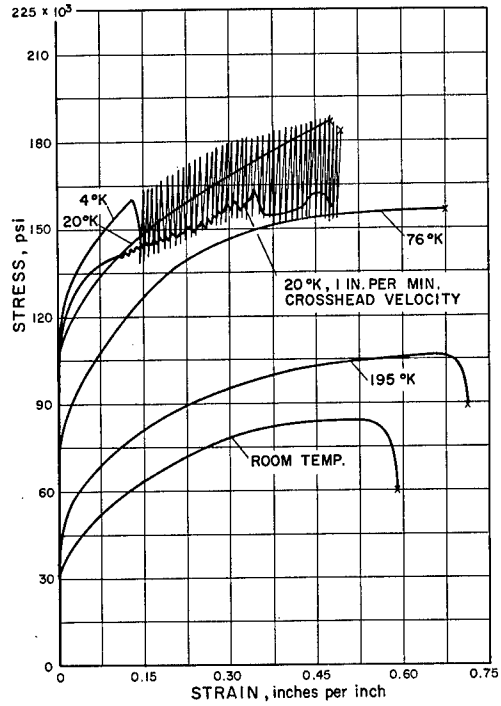

SS
321, ANNEALED

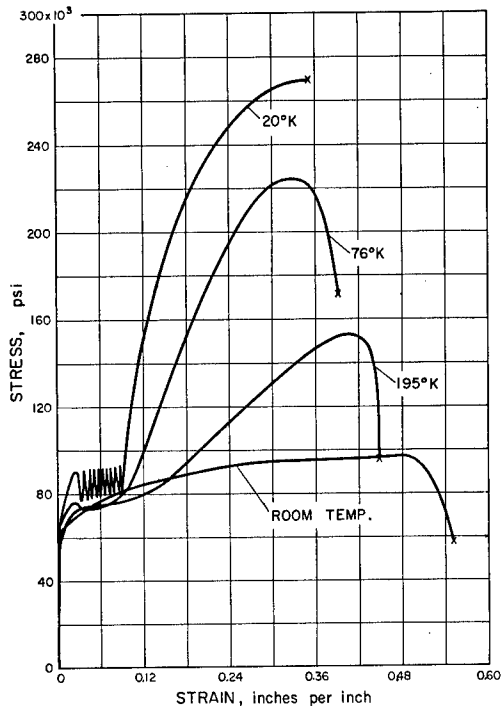
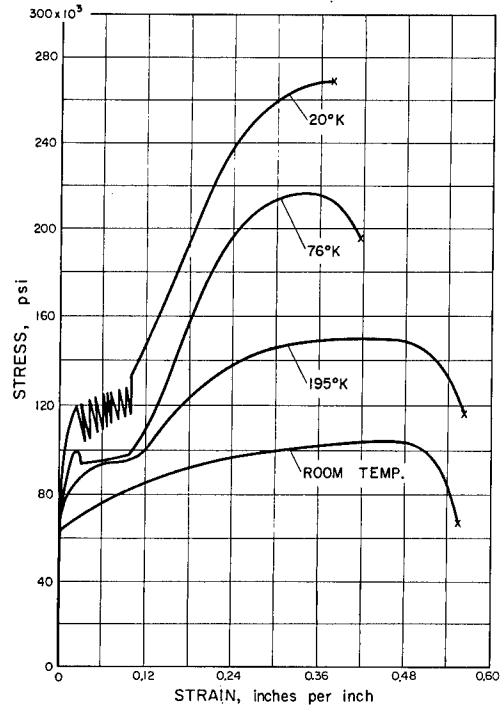
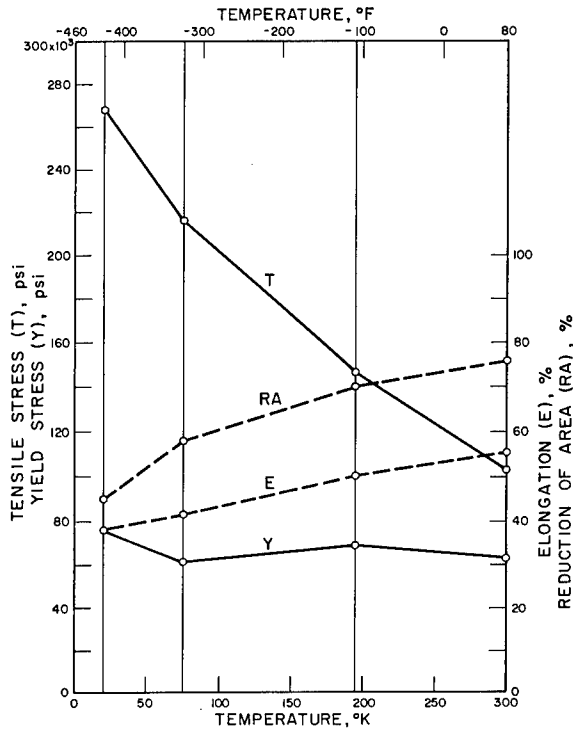
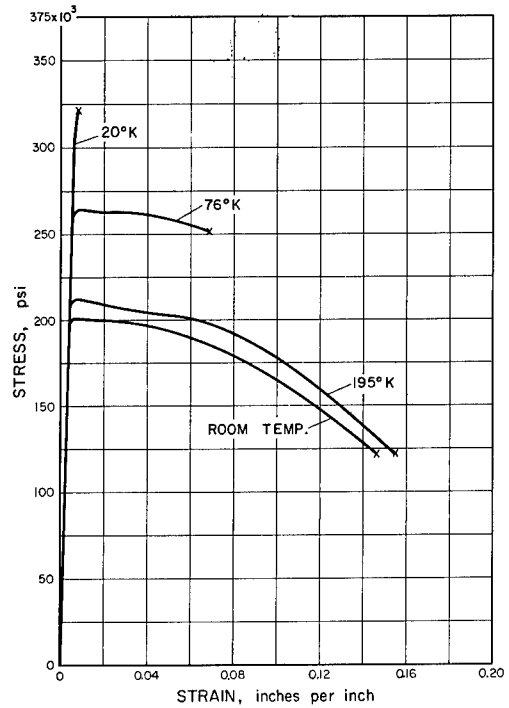
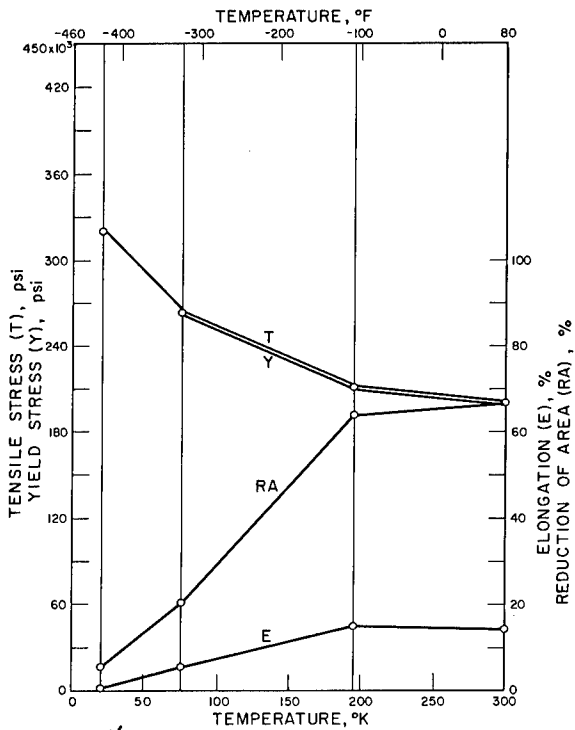

FIGURE 19. TENSILE PROPERTIES OF THE IRON ALLOYS.



SS
347, ANNEALED



SS
410, HEAT TREATED 1800 °F - 1 HR, OQ, TEMPERED 700 °F - 4 HR, AC

FIGURE 20. TENSILE PROPERTIES OF THE IRON ALLOYS.

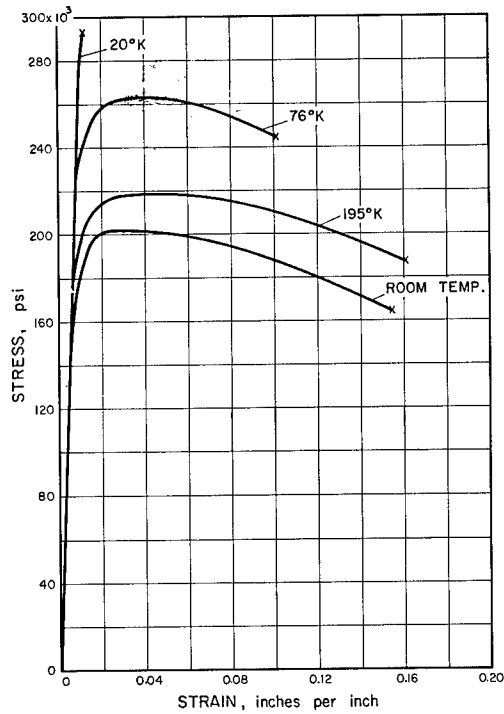
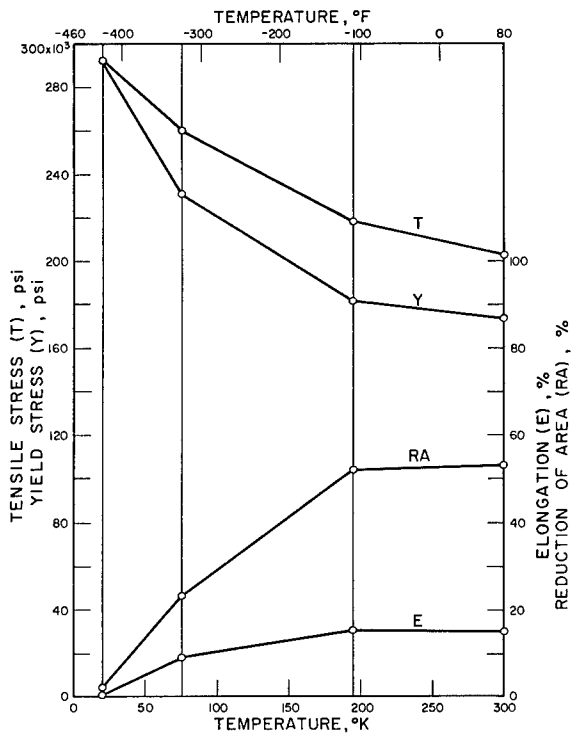

SS
416, HEAT TREATED 1800 °F - 1HR, OQ, TEMPERED 700 °F - 4HR, AC

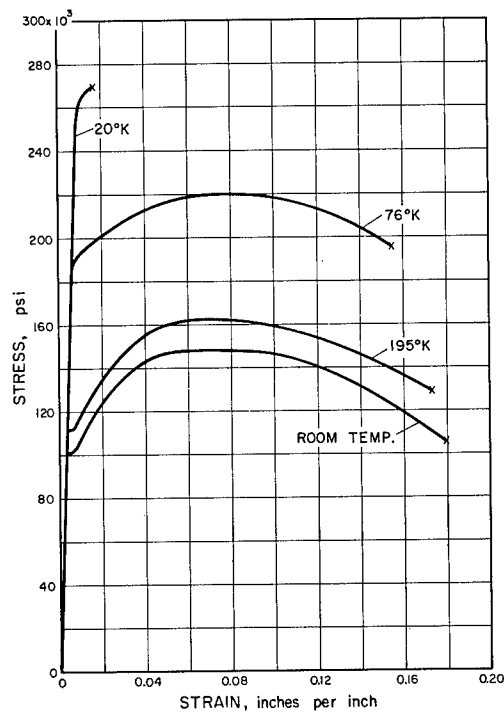
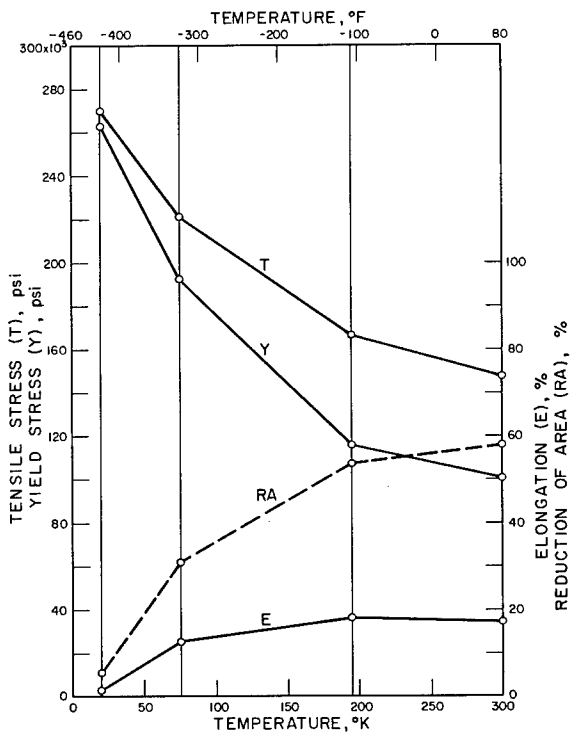

ES
1075, HEAT TREATED 1450 °F - 1HR, OQ, TEMPERED 720 °F - 1HR, AC

FIGURE 21. TENSILE PROPERTIES OF THE IRON ALLOYS.

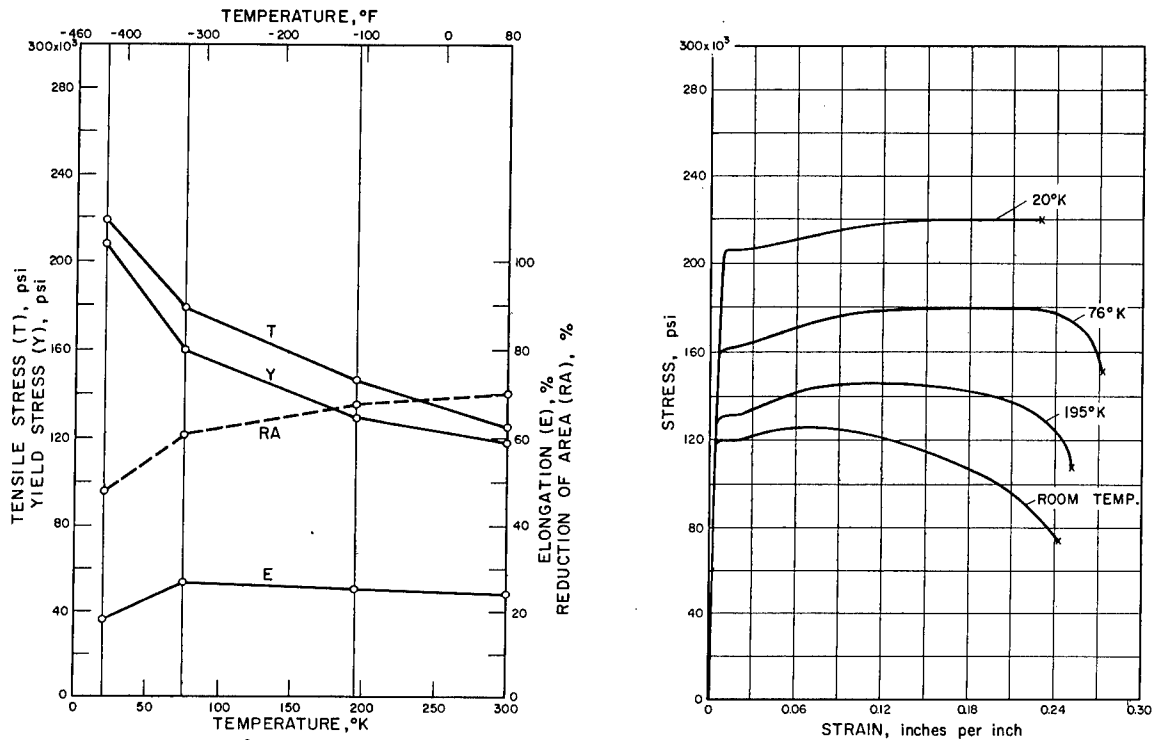

2800 ^{FEB} (9%Ni), DOUBLE NORMALIZED 1650 °F AND 1450 °F, TEMPERED 1050 °F - 2 HR

FIGURE 22. IMPACT PROPERTIES OF THE IRON ALLOYS.

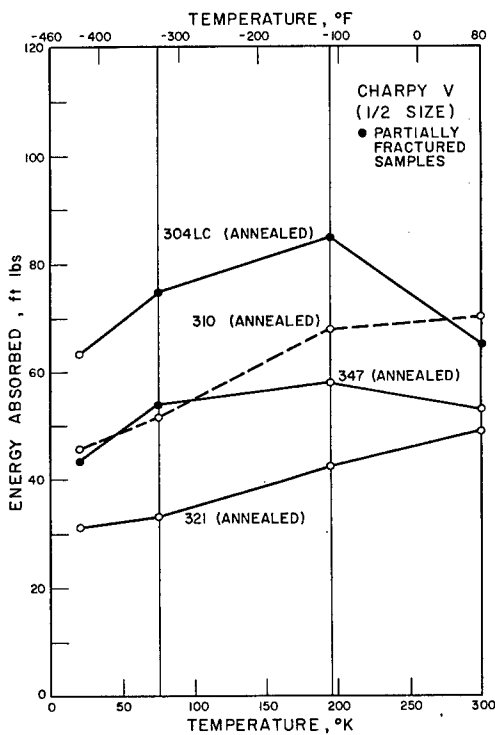
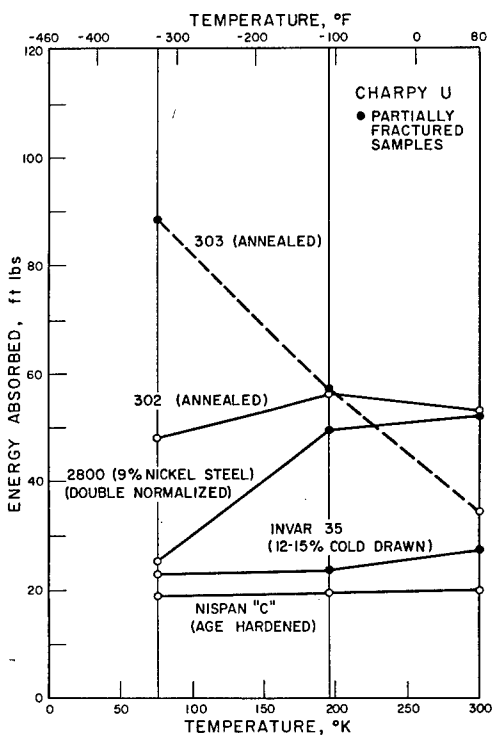
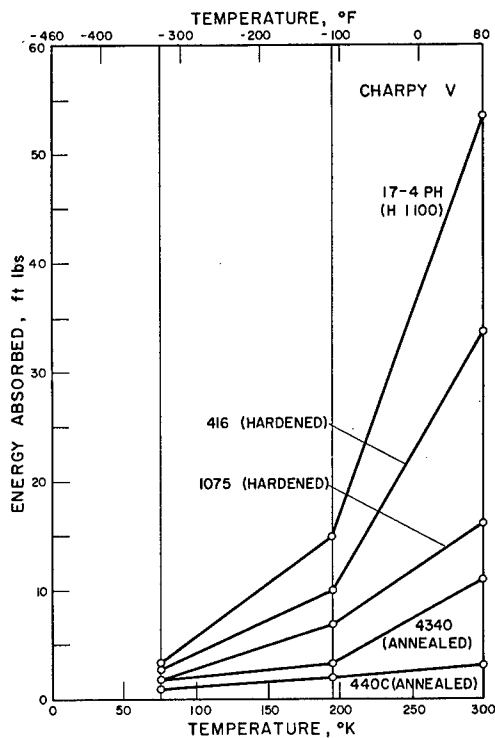
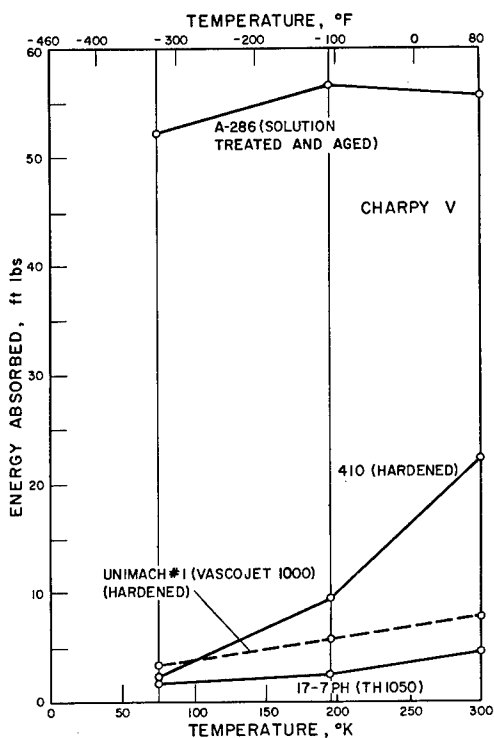
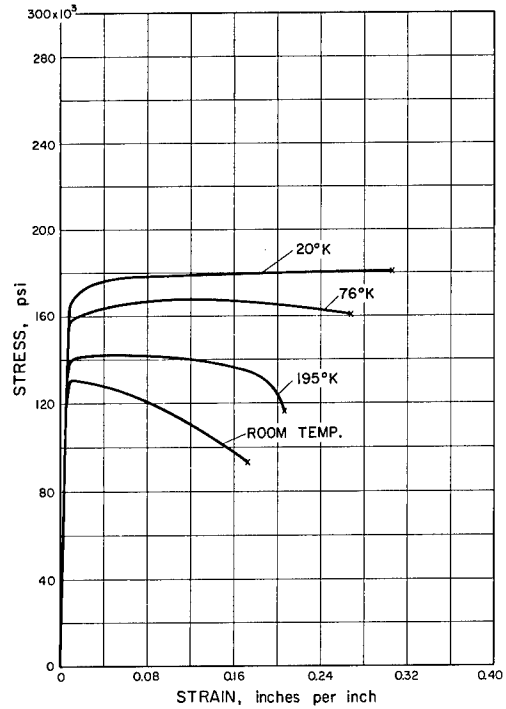
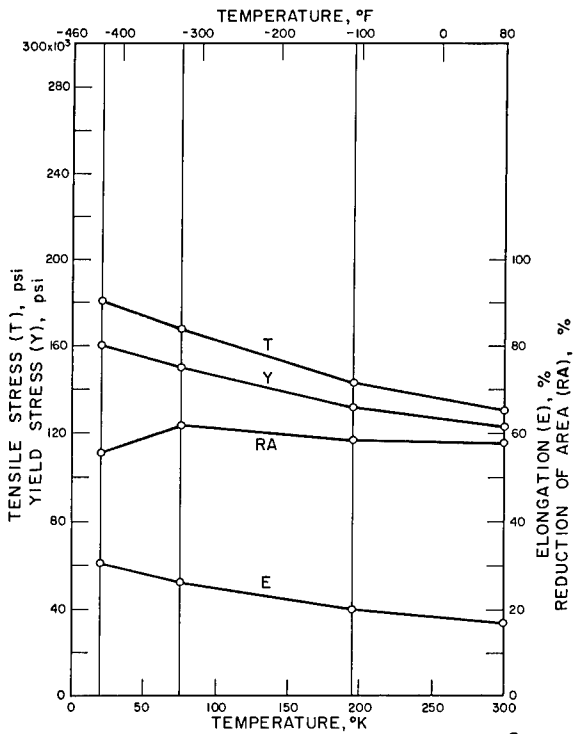
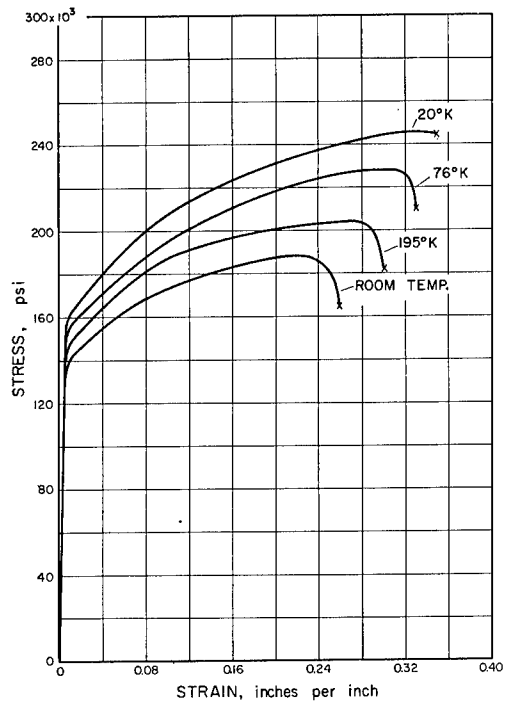
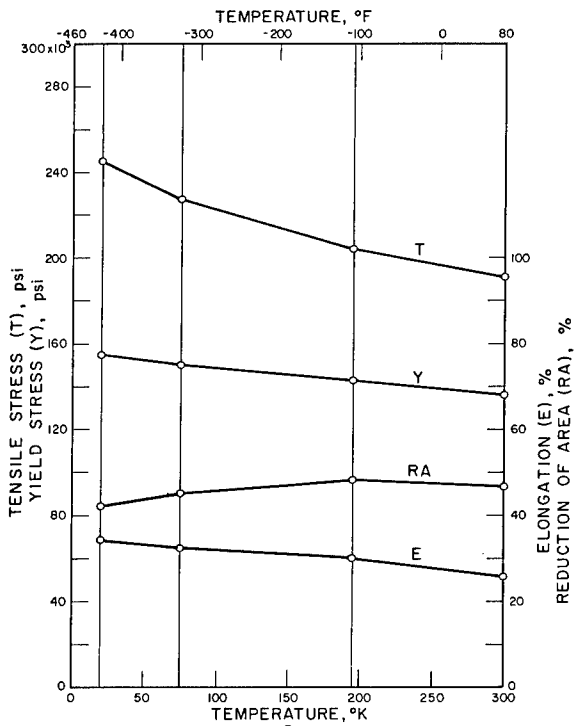

FIGURE 23. TENSILE PROPERTIES OF THE NICKEL ALLOYS.



NiB
INCONEL, 20% COLD DRAWN



NiB
INCONEL "X", HOT ROLLED, DIRECT AGED 1300 °F - 20 HR. AC TEMPERED

FIGURE 24. TENSILE PROPERTIES OF THE NICKEL ALLOYS.

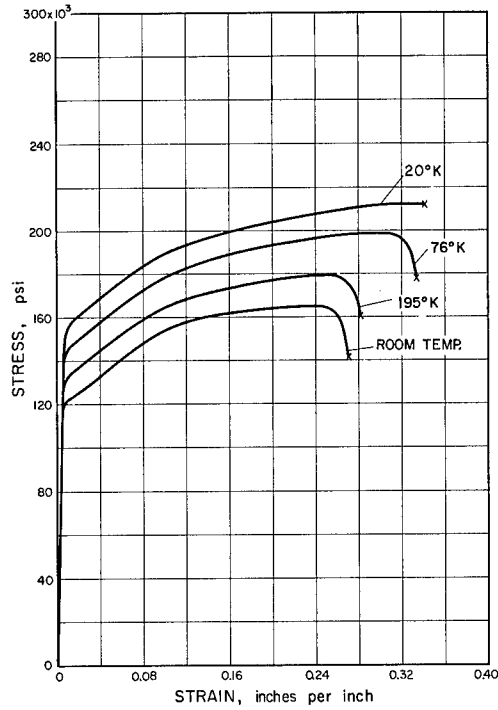
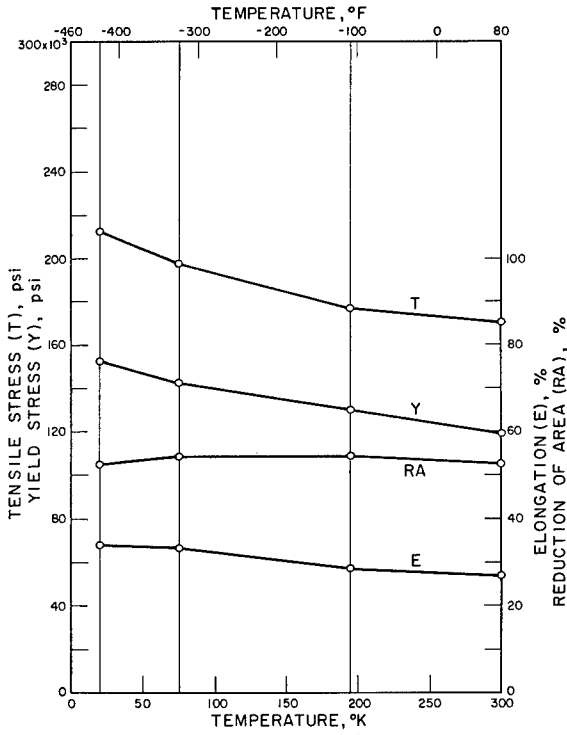

"K" MONEL ^{NiB}, AGE HARDENED 1100 °F - 21 HR, 1000 °F - 8 HR, AC

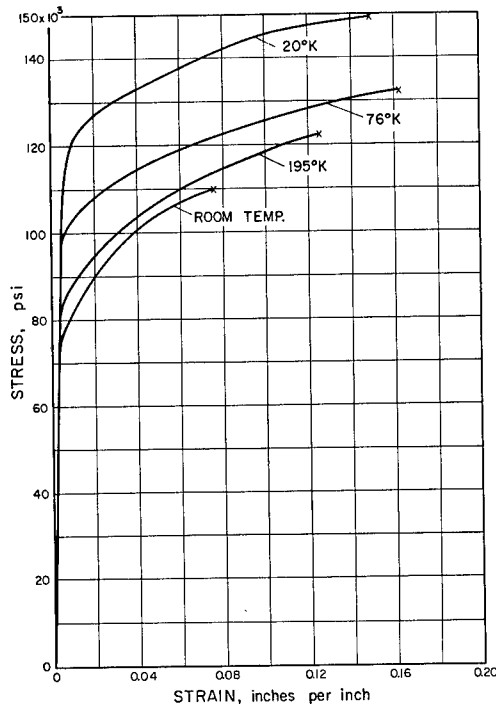
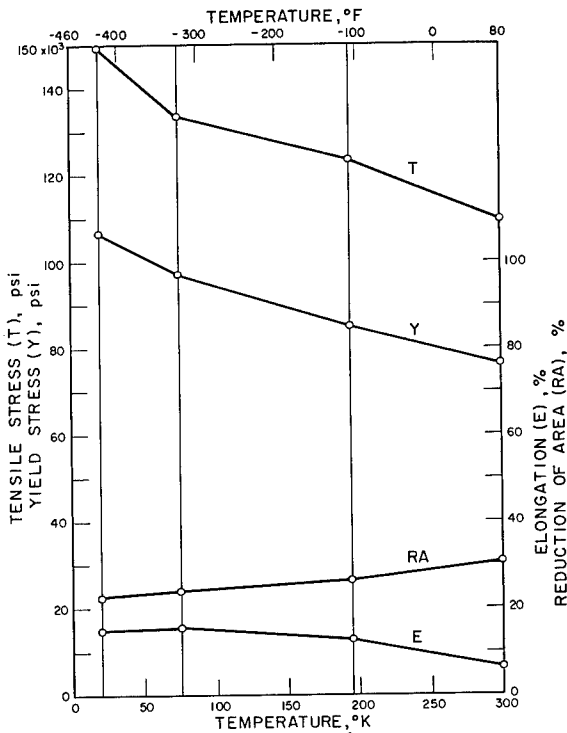

"S" MONEL ^{NiB}, CAST, ANNEALED 1600 °F - 1 HR, 1300 °F - 1/2 HR, OQ

FIGURE 25. TENSILE PROPERTIES OF THE NICKEL ALLOYS.

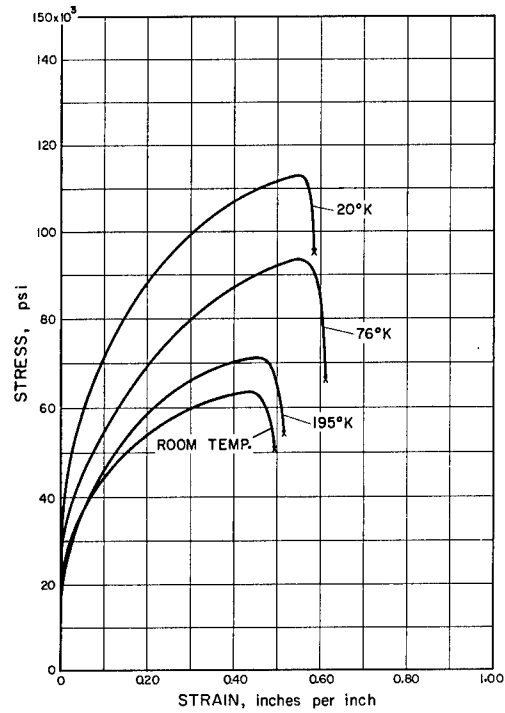
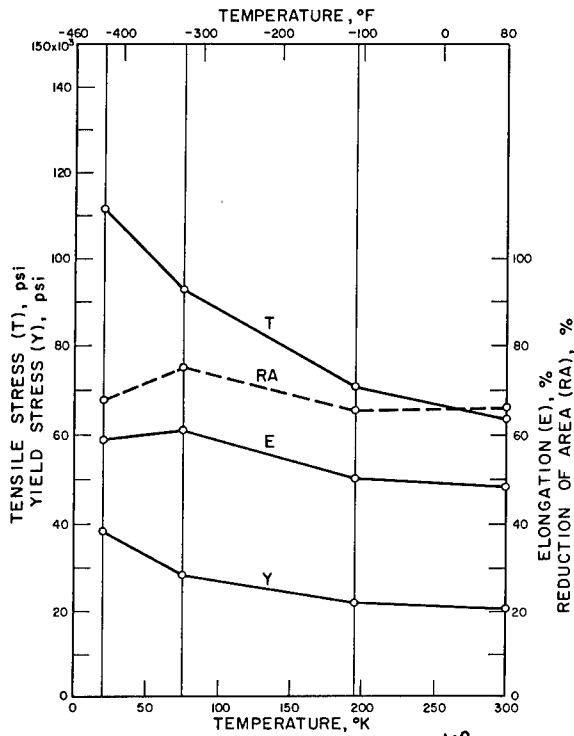

NiB
"A" NICKEL, ANNEALED 1725 °F - 1/2 HR

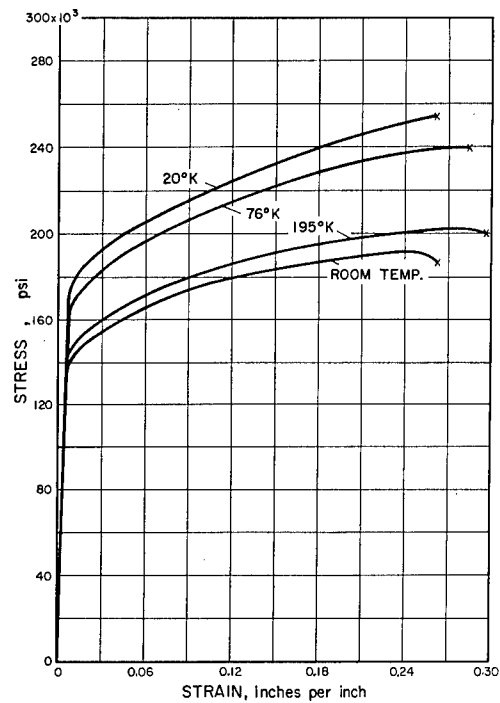
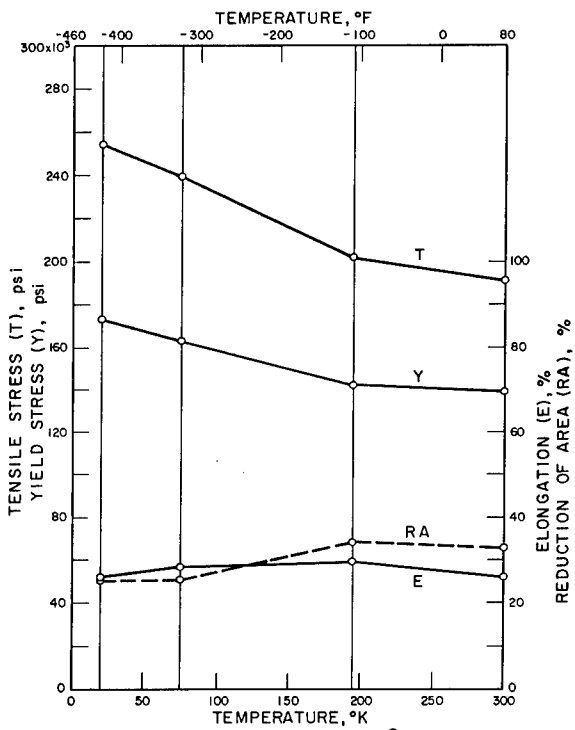

NiB
RENÉ 41, SOLUTION TREATED 1975 °F - 4 HR, WQ

FIGURE 26. IMPACT PROPERTIES OF THE NICKEL ALLOYS.

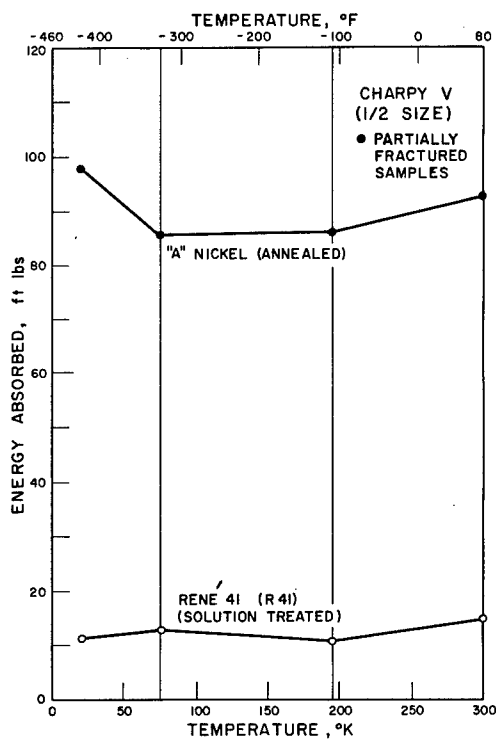
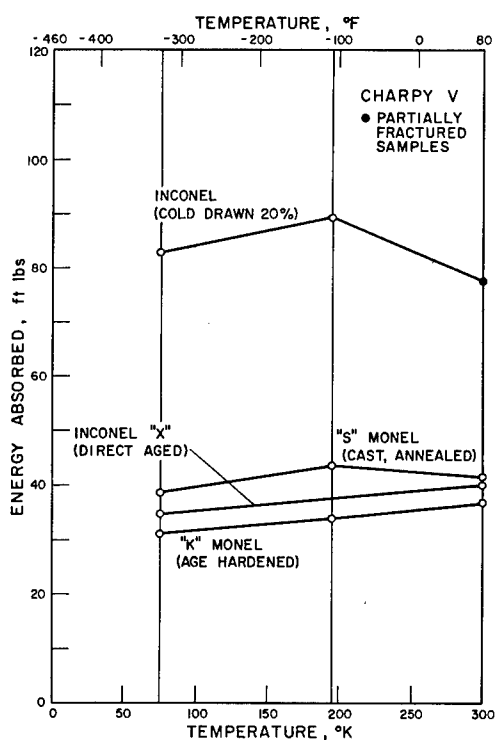
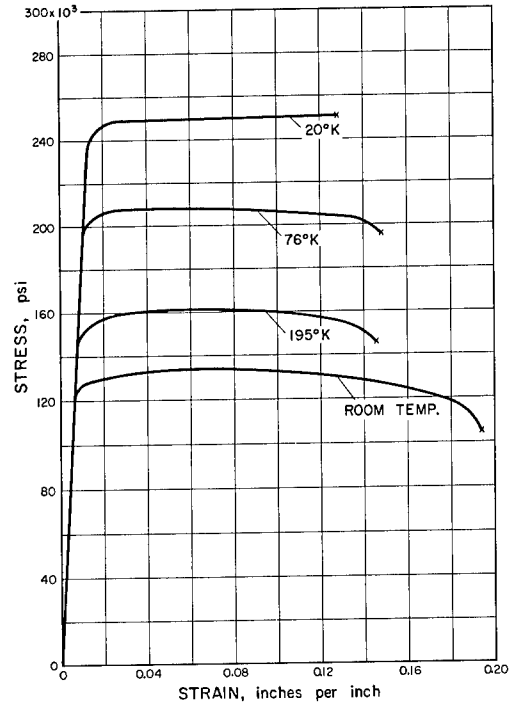
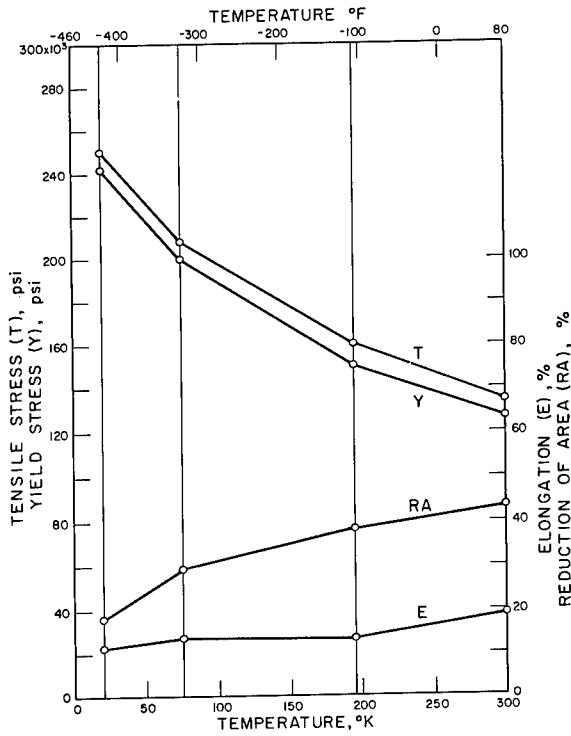
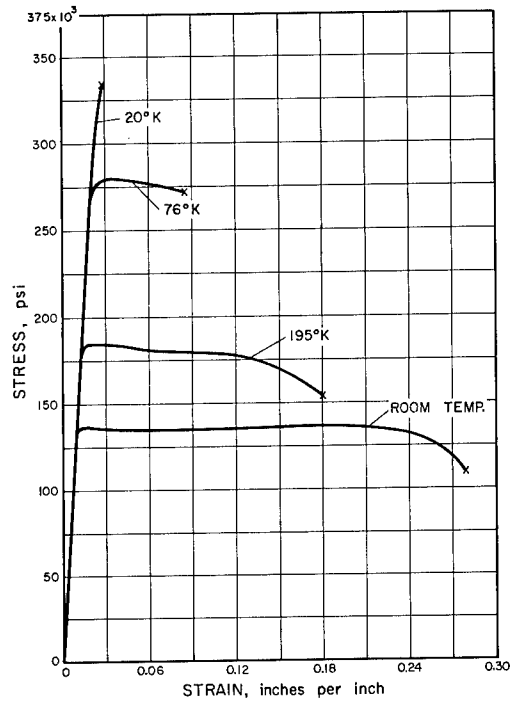
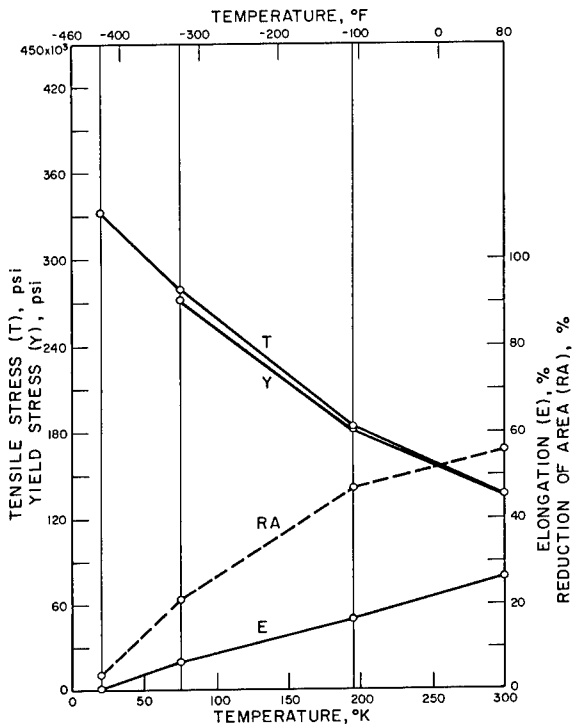

FIGURE 27. TENSILE PROPERTIES OF THE TITANIUM ALLOYS.



Ti
5Al - 2.5 Sn, ANNEALED



Ti
13V - 11Cr - 3Al, SOLUTION TREATED

FIGURE 28: TENSILE PROPERTIES OF THE TITANIUM ALLOYS.

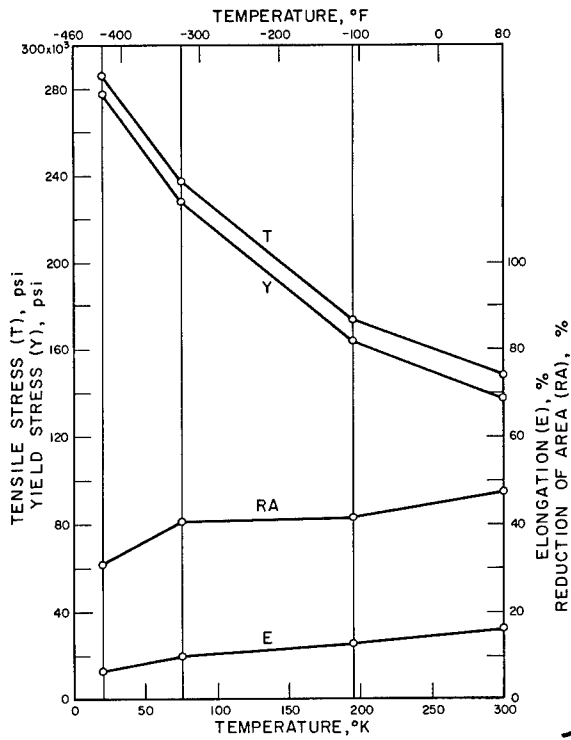

6Al-4V, ANNEALED

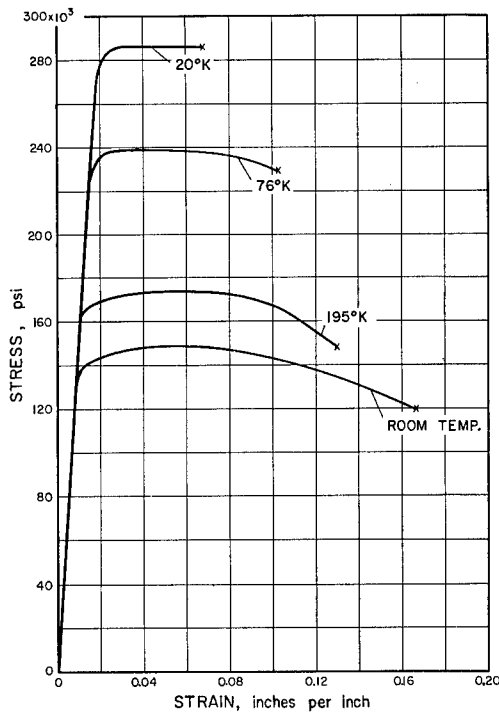
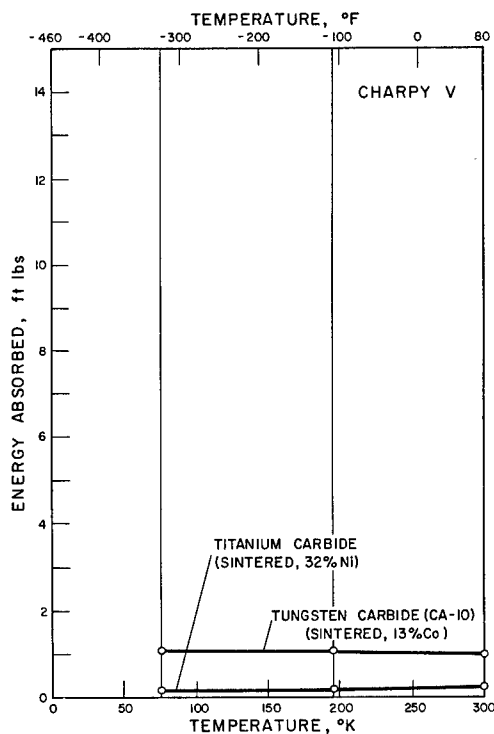
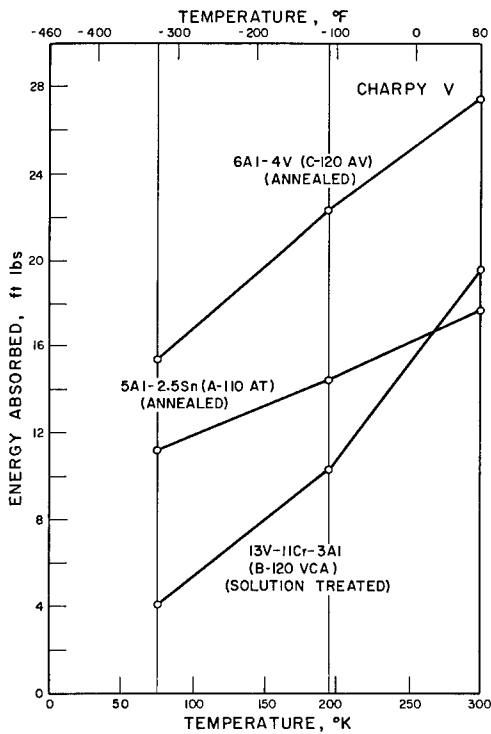

FIGURE 29. IMPACT PROPERTIES OF THE TITANIUM ALLOYS.

FIGURE 30. IMPACT PROPERTIES OF THE CARBIDES.



U.S. DEPARTMENT OF COMMERCE

Luther H. Hodges, *Secretary*

NATIONAL BUREAU OF STANDARDS

A. V. Astin, *Director*



THE NATIONAL BUREAU OF STANDARDS

The scope of activities of the National Bureau of Standards at its major laboratories in Washington, D.C., and Boulder, Colorado, is suggested in the following listing of the divisions and sections engaged in technical work. In general, each section carries out specialized research, development, and engineering in the field indicated by its title. A brief description of the activities, and of the resultant publications, appears on the inside of the front cover.

WASHINGTON, D.C.

Electricity. Resistance and Reactance. Electrochemistry. Electrical Instruments. Magnetic Measurements. Dielectrics. High Voltage. Absolute Electrical Measurements.

Metrology. Photometry and Colorimetry. Refractometry. Photographic Research. Length. Engineering Metrology. Mass and Scale. Volumetry and Densimetry.

Heat. Temperature Physics. Heat Measurements. Cryogenic Physics. Equation of State. Statistical Physics.

Radiation Physics. X-ray. Radioactivity. Radiation Theory. High Energy Radiation. Radiological Equipment. Nucleonic Instrumentation. Neutron Physics.

Analytical and Inorganic Chemistry. Pure Substances. Spectrochemistry. Solution Chemistry. Standard Reference Materials. Applied Analytical Research. Crystal Chemistry.

Mechanics. Sound. Pressure and Vacuum. Fluid Mechanics. Engineering Mechanics. Rheology. Combustion Controls.

Polymers. Macromolecules; Synthesis and Structure. Polymer Chemistry. Polymer Physics. Polymer Characterization. Polymer Evaluation and Testing. Applied Polymer Standards and Research. Dental Research.

Metallurgy. Engineering Metallurgy. Microscopy and Diffraction. Metal Reactions. Metal Physics. Electrolysis and Metal Deposition.

Inorganic Solids. Engineering Ceramics. Glass. Solid State Chemistry. Crystal Growth. Physical Properties. Crystallography.

Building Research. Structural Engineering. Fire Research. Mechanical Systems. Organic Building Materials. Codes and Safety Standards. Heat Transfer. Inorganic Building Materials. Metallic Building Materials.

Applied Mathematics. Numerical Analysis. Computation. Statistical Engineering. Mathematical Physics. Operations Research.

Data Processing Systems. Components and Techniques. Computer Technology. Measurements Automation. Engineering Applications. Systems Analysis.

Atomic Physics. Spectroscopy. Infrared Spectroscopy. Far Ultraviolet Physics. Solid State Physics. Electron Physics. Atomic Physics. Plasma Spectroscopy.

Instrumentation. Engineering Electronics. Electron Devices. Electronic Instrumentation. Mechanical Instruments. Basic Instrumentation.

Physical Chemistry. Thermochemistry. Surface Chemistry. Organic Chemistry. Molecular Spectroscopy. Elementary Processes. Mass Spectrometry. Photochemistry and Radiation Chemistry.

Office of Weights and Measures.

BOULDER, COLO.

Cryogenic Engineering Laboratory. Cryogenic Equipment. Cryogenic Processes. Properties of Materials. Cryogenic Technical Services.

CENTRAL RADIO PROPAGATION LABORATORY

Ionosphere Research and Propagation. Low Frequency and Very Low Frequency Research. Ionosphere Research. Prediction Services. Sun-Earth Relationships. Field Engineering. Radio Warning Services. Vertical Soundings Research.

Radio Propagation Engineering. Data Reduction Instrumentation. Radio Noise. Tropospheric Measurements. Tropospheric Analysis. Propagation-Terrain Effects. Radio-Meteorology. Lower Atmosphere Physics.

Radio Systems. Applied Electromagnetic Theory. High Frequency and Very High Frequency Research. Frequency Utilization. Modulation Research. Antenna Research. Radiodetermination.

Upper Atmosphere and Space Physics. Upper Atmosphere and Plasma Physics. High Latitude Ionosphere Physics. Ionosphere and Exosphere Scatter. Airglow and Aurora. Ionospheric Radio Astronomy.

RADIO STANDARDS LABORATORY

Radio Physics. Radio Broadcast Service. Radio and Microwave Materials. Atomic Frequency and Time-Interval Standards. Radio Plasma. Millimeter-Wave Research.

Circuit Standards. High Frequency Electrical Standards. High Frequency Calibration Services. High Frequency Impedance Standards. Microwave Calibration Services. Microwave Circuit Standards. Low Frequency Calibration Services.