

P

NASA TECHNICAL NOTE

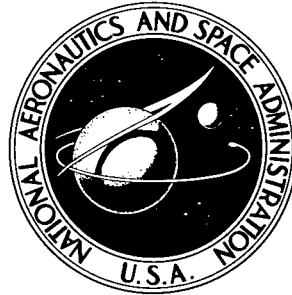

NASA TN D-1981

NASA TN D-1981

[Handwritten signature]
AMPTIAC

54669

**INVESTIGATION OF THE IMPACT
OF COPPER FILAMENTS INTO
ALUMINUM TARGETS AT VELOCITIES
TO 16,000 FEET PER SECOND**

DISTRIBUTION STATEMENT A
Approved for Public Release
Distribution Unlimited

*by C. Robert Nysmith, James L. Summers,
and B. Pat Denardo*

*Ames Research Center
Moffett Field, California*

**Reproduced From
Best Available Copy**

20011129 165

INVESTIGATION OF THE IMPACT OF COPPER FILAMENTS
INTO ALUMINUM TARGETS AT VELOCITIES TO
16,000 FEET PER SECOND

By C. Robert Nysmith, James L. Summers,
and B. Pat Denardo

Ames Research Center
Moffett Field, Calif.

NATIONAL AERONAUTICS AND SPACE ADMINISTRATION

For sale by the Office of Technical Services, Department of Commerce,
Washington, D.C. 20230 -- Price \$0.50

INVESTIGATION OF THE IMPACT OF COPPER FILAMENTS

INTO ALUMINUM TARGETS AT VELOCITIES TO

16,000 FEET PER SECOND*

By C. Robert Nysmith, James L. Summers, and
B. Pat Denardo

SUMMARY

One-half-inch-diameter aluminum spheres were fired into thin copper filaments (0.0025-inch diameter and 0.75-inch length) at velocities to 16,000 feet per second, then recovered and sectioned to determine the damage. The principal variable was the filament angle of inclination. Microscopic examination of the sectioned targets and photographs revealed the various crater characteristics and penetration parameters for each shot.

As the angle of inclination increased from 0° to 7° , the depth of penetration decreased by a factor greater than 3 with most of the decrease occurring in the range from 4° to 5° . Above 10° inclination angle, the penetration decreased more gradually to a final depth at broadside impact of approximately 1/10 that for end-on impact. The characteristic features of the craters also changed in these inclination ranges.

Limited tests with filaments of 0.0015-inch diameter showed a decrease in penetration approximately in proportion to the decrease in diameter. This result is very preliminary and may not be applicable to conditions other than those of this test. Incidental observations showed that small curvature of the filament may have a large effect on depth of penetration for end-on impacts but has essentially no effect for impacts of inclined filaments. The data are used to evaluate the probability of penetration greater than a selected depth for randomly oriented filaments.

INTRODUCTION

Investigations concerning the impact of thick metal targets by low-fineness-ratio projectiles, such as spheres and cylinders, have yielded a considerable amount of data relating the various impact parameters. This information has made it possible to predict, with fair confidence, the penetration of a target by a given projectile at velocities to about 30,000 ft/sec. Extrapolation of this information to higher impact velocities depends upon the assumption made as to the physical law that governs cratering at these higher velocities.

*The unclassified portion of a paper presented at the Sixteenth Meeting of AMRAC, Oct. 22-24, 1963.

On the other hand, information concerning the impact of targets by high-fineness-ratio projectiles is rather limited and has been obtained at relatively low-impact velocities with few variables considered. Even so, the information indicates that high-fineness-ratio projectiles are more efficient in penetrating targets than corresponding blunt projectiles of the same mass (see ref. 1). Thus, it is felt that more information pertaining to the impact of high-fineness-ratio projectiles should be obtained so that the penetration efficiency of these bodies can be evaluated.

With this in mind, a program of research directed toward determining the damage produced by the impact of high-fineness-ratio projectiles upon structures is being conducted at the NASA Ames Research Center. The results described here concern the depth of penetration of high-fineness-ratio copper filaments into aluminum targets. The tests were conducted at a nominal velocity of 15,000 ft/sec and for inclination angles from 0° to 90° .

TEST PROCEDURE

The launching of a projectile from a gun (the basic technique in these tests) involves accelerating the projectile to high velocity in a short time; as the launch velocity is increased, acceleration loads on the projectile also increase. Low-fineness-ratio projectiles, such as spheres and cylinders, can tolerate acceleration loads as high as the compressive strength of the projectile material and thus can be launched to fairly high velocities. High-fineness-ratio projectiles, on the other hand, tend to fail as columns when accelerated axially, and it is virtually impossible to launch them to any reasonable velocity. To circumvent this limitation, an unusual experimental technique was used in this program in that the target was launched into a stationary projectile. The "target" in this case was an aluminum sphere. The "projectiles" were fine copper filaments placed directly in the path of the sphere.

The spheres were made of 1/2-inch-diameter 2017-T4 aluminum and were launched from a 20-millimeter light-gas gun in nylon sabots. Upon leaving the launch tube, the targets entered the first section of the flight-test range which contained air at a pressure of 4 mm Hg. This pressure was sufficient to insure the target's separation from the sabot, so that impact with the filament would not be complicated by sabot effects, but was low enough that deceleration of the target in this section was negligible. This section of the range was 25 feet long, had three velocity measuring stations, and was separated from the second section by a 1-mil mylar diaphragm. The second section of flight-test range, approximately 200 feet long, contained air at one atmosphere and had four velocity measuring stations. The target decelerated in this section to a velocity at impact of about 3500 feet per second. A model catcher made of polystyrene foam and cotton waste was located at the end of the second section. As the result of this particular recovery technique, damage to the target on impact was very slight. Ablation of the target due to aerodynamic heating in flight did, however, occur and had to be accounted for.

The wire filaments were supported on the range center line by 1/4-mil nylon strands just uprange of the diaphragm at the end of the first section of the flight-test range. Angles of inclination could be varied by placing the supporting nylon strands in various notches in the holder as shown by sketch (a). Holder tolerances were such that angles of inclination were held within an accuracy of 20 minutes of arc. A 90° bend was made in the rear of the filament to insure its remaining in place during range evacuation and to give a clearer representation of the filament-target orientation at impact. Two filament diameters were used in this series of tests, 0.0025 inch and 0.0015 inch. The length of the straight sections was always 3/4 inch, and the length of the tails, as a result of the 90° bend mentioned above, was 1/8 inch. Filament fineness ratios then were 300 and 500, respectively. All filaments were straightened before they were mounted in the holder. This was done by heating the wires electrically and simultaneously applying a tensile load. This process annealed the copper filaments and reduced the filament curvature to what was felt to be a practical minimum. In some cases several filaments were placed in the holder (by adding additional sets of nylon supporting strands) and several noninterfering impacts were obtained from a single shot.

FILAMENT SETUP

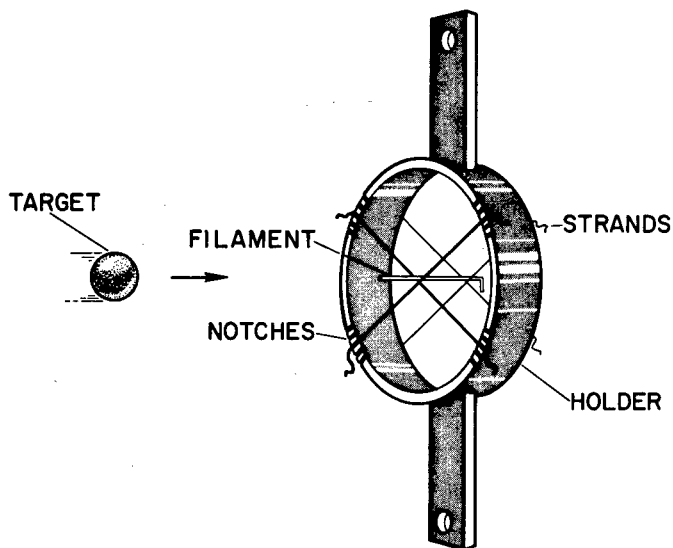

Sketch (a)

The velocity at impact was determined from the time-distance history obtained by the seven spark-shadowgraph stations located along the flight path. The method of plotting the reciprocal of the model velocity versus time described in reference 2 was used.

After recovery, the targets were sectioned parallel to the crater plane on a milling machine and the penetration was measured microscopically. Figure 1(a) is a photograph of a target just after recovery and prior to sectioning. One can see the impression made by the 90° bend and the ablation due to flight through the second section of the flight-test range. Figure 1(b) is a photograph of the same target after sectioning. The crater is clearly visible. The loss of material due to ablation was estimated in determining the various penetration parameters.

DISCUSSION OF RESULTS

Tests were conducted to determine the effect of filament inclination upon maximum depth of penetration. The inclination is defined here as the angle between the filament longitudinal axis and the flight trajectory. It is not a

function of the obliquity which is defined as the angle between the trajectory and the radius vector of the sphere at the point of impact (a definition consistent with the usual definition of obliquity for impact work). Sketch (b) below illustrates these two angles. The maximum depth of penetration is measured from the target surface parallel to the trajectory and thus is not dependent upon target obliquity.

FILAMENT-TARGET ORIENTATION

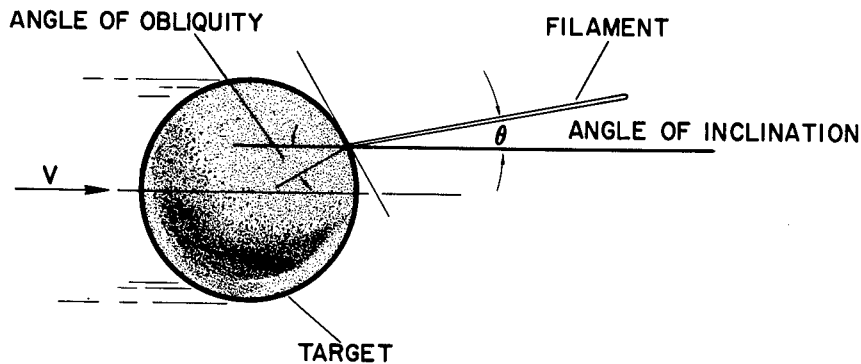

Sketch (b)

Plotted in figure 2 is the maximum depth of penetration in inches versus filament inclination in degrees for 0.0025-inch-diameter filaments of fineness ratio 300. Each square symbol shown in figure 2 represents one experimental point determined from target examination and measurement. Flagged symbols indicate that the sphere was completely penetrated by the filament. However, it may be noted that the penetration in these cases was always less than 1/2 inch, the target diameter. This simply indicates that the filaments impacted the spheres slightly off center.

It should be noted that target velocities from the 20-mm shock-heated light-gas gun used in this series of tests are not precisely repeatable from round to round. Thus, square symbols in figure 2 represent data in which the impact velocities varied from 13,500 to 15,700 ft/sec. It is felt that one can adjust the data to a common velocity so long as the adjusted data are in the same impact regime in which the original data were acquired. (See ref. 3.) It was decided to adjust the present data to a common velocity of 15,000 ft/sec. If it is assumed that the volume of material removed is proportional to the kinetic energy of the projectile, then the penetration will be proportional to the 2/3 power of the velocity. Thus it will be assumed that

$$p \approx V^{2/3}$$

as in reference 3.

The original data of figure 2 adjusted to a velocity of 15,000 ft/sec are replotted as round symbols and the solid curve of figure 2. The two curves of figure 2 differ only slightly. For normal impacts (0° angle of inclination) and broadside impacts (90° angle of inclination) there is a degree of scatter in the data. For end-on impacts, this is felt to be a result of the remaining curvature of the filaments which would be expected to influence the depth of penetration; for broadside impacts, ablation loss was of the order of the depth of penetration, and deduced penetration depths were, accordingly, very sensitive to ablation-loss measurements.

It is interesting to note that there appears to be essentially no scatter in the data throughout the inclination range from 4° to 15° . This indicates that small filament curvature does not influence inclined impacts.

The data of figure 2 show that impacts occurring at 0° angle of inclination produce relatively deep craters. As the inclination is increased to 4° the penetration decreases rapidly. Craters from impacts within this inclination range, however, are similar in appearance in that they have small diameters (about 10 filament diameters) and are relatively deep. Figures 3(a) and 3(b) are photographs of sectioned targets impacted at 0° and 4° , respectively. The similarity between these two craters is evident.

As the inclination is increased from 4° to 5° , the penetration decreases abruptly. In figure 2 the penetration resulting from impact at 5° is roughly half that from impact at 4° . One would suspect that the cratering process must undergo some drastic change to account for this phenomenon. Figure 3(c) is a photograph of a sectioned crater from impact at 5° inclination. Comparison of this figure with figure 3(b) (impact at 4°) shows that these craters are dissimilar. The 5° inclination impact crater appears to be fairly shallow and relatively broad in the plane of the filament while the other is narrow and deep. It appears that the nature of the cratering process has undergone a transition within this small inclination range.

Increasing the inclination from 5° to 15° reduces the penetration more gradually. Figures 3(d), 3(e), and 3(f) are photographs of sectioned models after impact at inclination angles of 7° , 10° , and 15° , respectively. These craters all exhibit characteristics similar to those observed for impact at 5° . As the inclination is increased from 5° to 15° , the penetration decreases systematically and the craters become broader, in the filament plane, according to the projected filament length in the direction of the target trajectory.

At angles of inclination from 15° to 90° the penetration decreases a small amount and it is clear that damage within this inclination range is similar to broadside impacts.

In addition to the inclination tests described above, a number of firings were made with a 0.0015-inch-diameter filament with fineness ratio 500 at 0° and 90° inclination. It was observed that for these inclination extremes, a 66-percent increase in filament diameter resulted in an 85-percent increase in penetration. It should be pointed out that this result is very preliminary in nature and should be used with caution. Future tests will enable the effects of this variable to be evaluated more completely.

The information presented in the previous sections may be used to estimate the probability that a particular impact of one of these filaments will produce a crater of greater than a given depth in an aluminum structure. First, it is assumed that the vehicle being considered will be struck by the given filament. Second, it is assumed that impacts will occur at a velocity of 15,000 ft/sec. The probability to be calculated is nothing more than the probability that the impact will occur at an inclination, θ , less than that which yields the chosen penetration. If the distribution of filament inclination is assumed to be random, the probability that impact will occur at $\theta < \theta_c$ is

$$\eta = 1 - \cos \theta_c$$

where $\theta = 0^\circ$ for end-on impact and 90° for broadside impact.

As shown in figure 4, for the assumed conditions, all impacts yield penetrations greater than 0.039 inch; thus, the probability is 1.0. The probability of twice this penetration is 0.32, and the probability of four times this penetration is 0.0045. This illustrates the extreme insensitivity to inclination in the range from 15° to 90° .

Extrapolation of these data to other materials, projectile fineness ratios, and impact velocities is not possible because these parameters have not been varied sufficiently. It is interesting, however, to compare the penetrating ability of the inclined filaments with that of spheres as functions of their respective masses: First, a sphere with a mass 130 times that of a filament is required to penetrate to the same depth as the filament striking end-on. Second, a filament at 39° inclination penetrates to the same depth as a sphere of the same mass. These observations clearly show the penetrating superiority of aligned filaments over spheres on a mass-to-mass basis.

Ames Research Center
National Aeronautics and Space Administration
Moffett Field, Calif., July 9, 1963

REFERENCES

1. Summers, James L., and Niehaus, William R.: A Preliminary Investigation of the Penetration of Slender Metal Rods in Thick Metal Targets. NASA TN D-137, 1959.
2. Yee, Layton, Bailey, Harry E., and Woodward, Henry T.: Ballistic Range Measurements of Stagnation-Point Heat Transfer in Air and in Carbon Dioxide at Velocities up to 18,000 Feet Per Second. NASA TN D-777, 1961.
3. Summers, James L.: Investigation of High-Speed Impact: Regions of Impact and Impact at Oblique Angles. NASA TN D-94, 1959.



AR-1583-23

(a) Photograph of model after recovery and prior to sectioning.

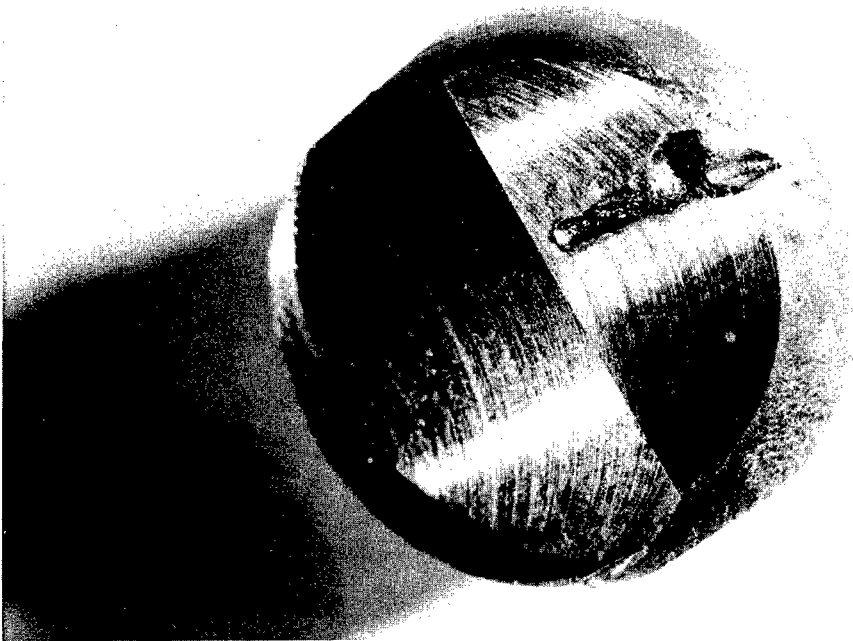

AR-1583-54

(b) Photograph of model after sectioning.

Figure 1.- Model before and after sectioning.

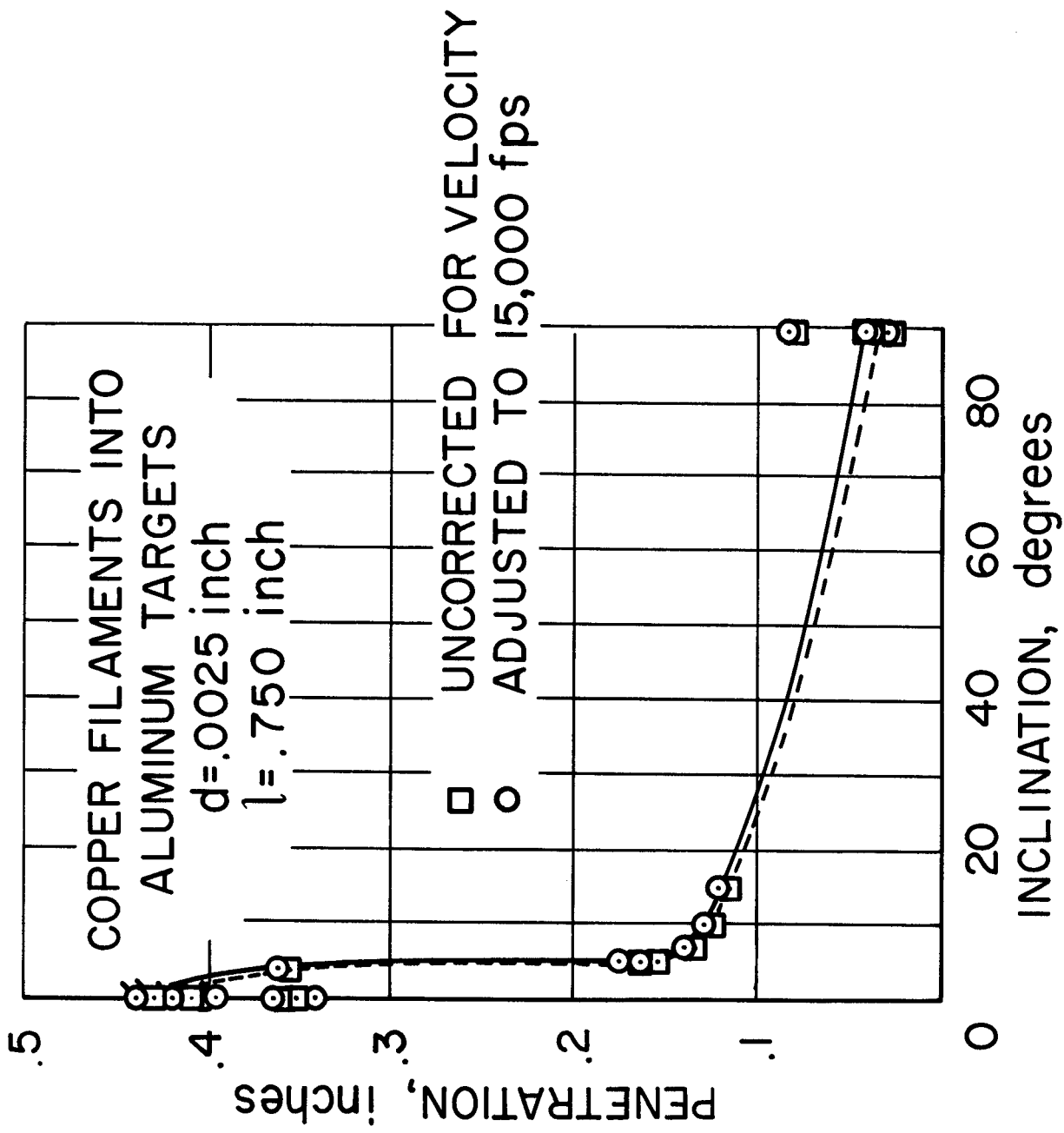
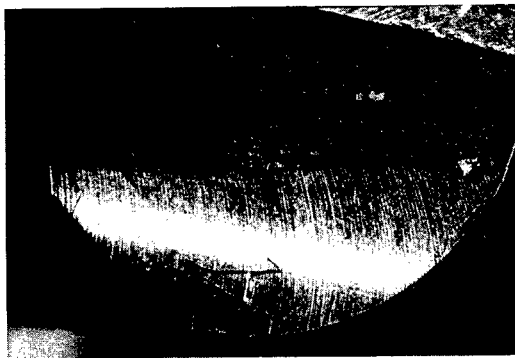
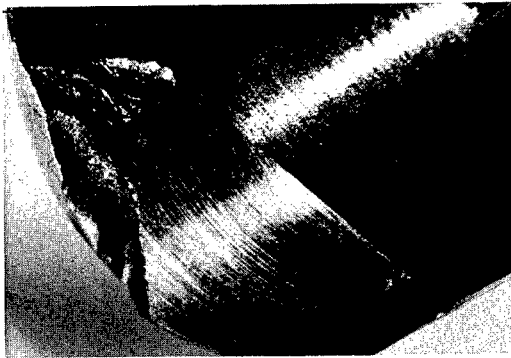

Figure 2.- Variation of penetration with angle of inclination.



AR-1583-13

(a) $\theta = 0^\circ$



AR-1583-46

(d) $\theta = 7^\circ$

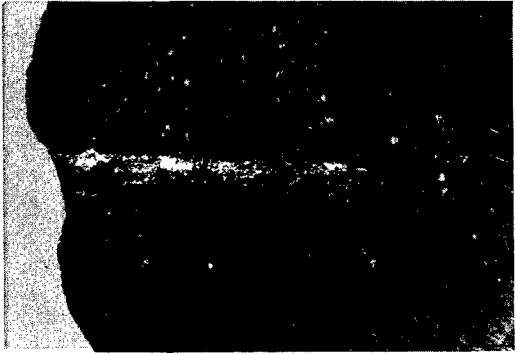

AR-1583-47

(b) $\theta = 4^\circ$

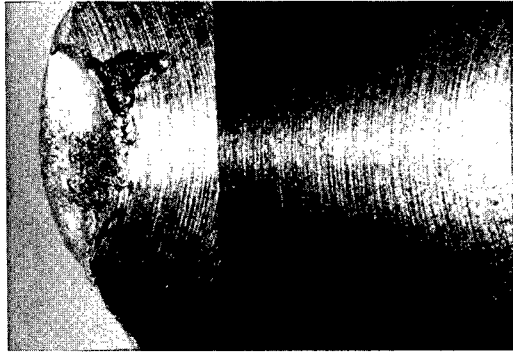

AR-1583-43

(e) $\theta = 10^\circ$



AR-1583-41

(c) $\theta = 5^\circ$

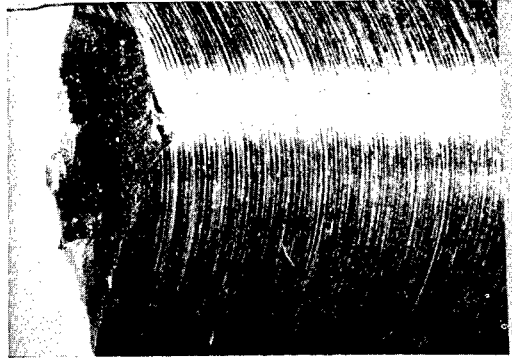

AR-1583-44

(f) $\theta = 15^\circ$

Figure 3.- Photographs of sectioned filament craters at various angles of inclination.

COPPER FILAMENTS
 INTO
 ALUMINUM TARGETS

$l = .750$ inch
 $d = .0025$ inch
 $v = 15,000$ fps

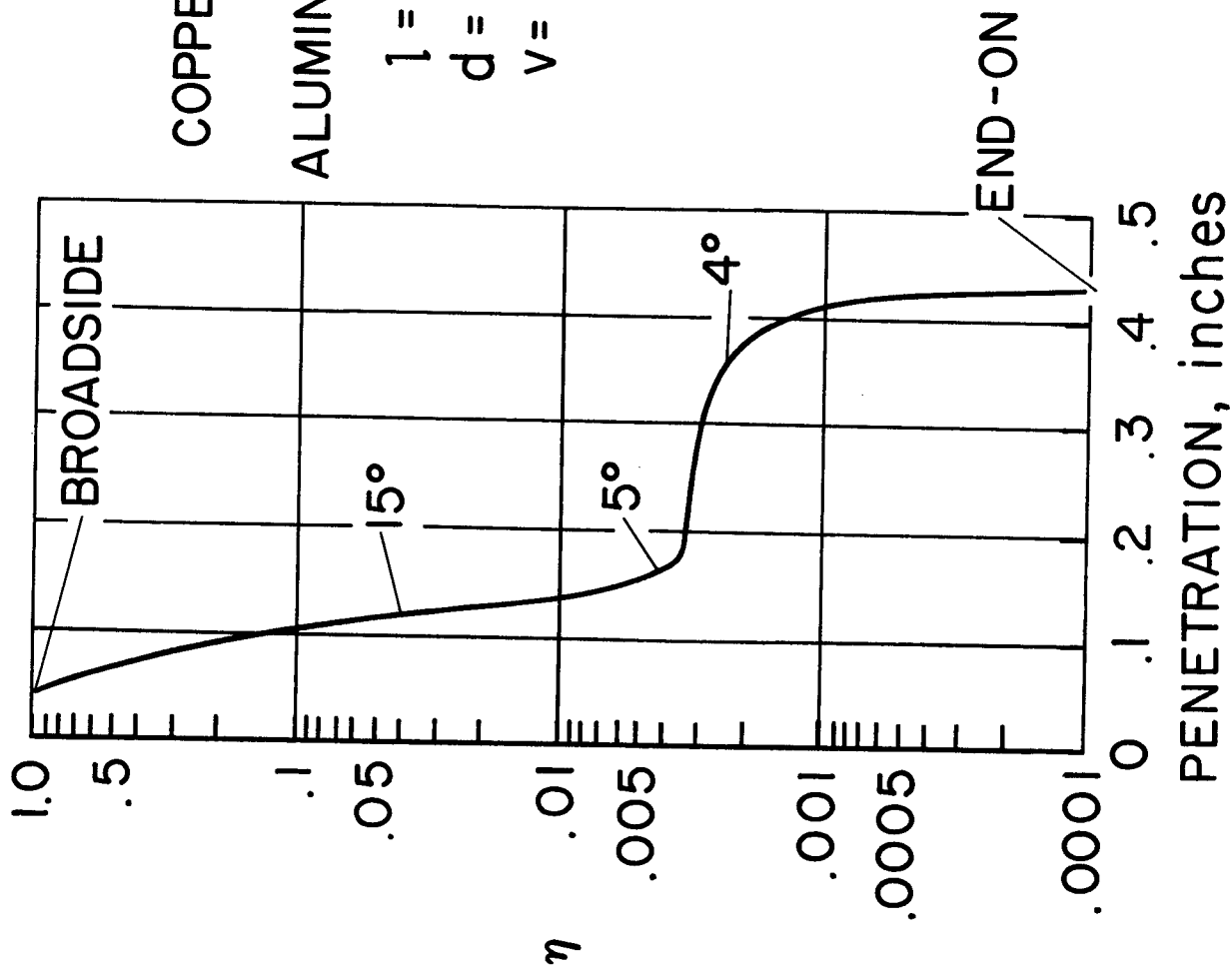

Figure 4.- Probability of penetration greater than a selected depth for randomly oriented filaments.

NASA TN D-1981
 National Aeronautics and Space Administration.
 INVESTIGATION OF THE IMPACT OF COPPER
 FILAMENTS INTO ALUMINUM TARGETS AT
 VELOCITIES TO 16,000 FEET PER SECOND.
 C. Robert Nysmith, James L. Summers, and
 B. Pat Denardo. February 1964. 10p. OTS price,
 \$0.50. (NASA TECHNICAL NOTE D-1981)

Aluminum targets were impacted by thin copper
 filaments to determine the effect of filament angle
 of inclination upon maximum depth of penetration.
 The effects of small filament curvature, filament
 diameter, and impact velocity are also discussed.
 The data are used to evaluate the probability of
 penetrations greater than any given depth by fila-
 ments having random orientation.

- I. Nysmith, C. Robert
- II. Summers, James L.
- III. Denardo, B. Pat
- IV. NASA TN D-1981

NASA

NASA TN D-1981
 National Aeronautics and Space Administration.
 INVESTIGATION OF THE IMPACT OF COPPER
 FILAMENTS INTO ALUMINUM TARGETS AT
 VELOCITIES TO 16,000 FEET PER SECOND.
 C. Robert Nysmith, James L. Summers, and
 B. Pat Denardo. February 1964. 10p. OTS price,
 \$0.50. (NASA TECHNICAL NOTE D-1981)

Aluminum targets were impacted by thin copper
 filaments to determine the effect of filament angle
 of inclination upon maximum depth of penetration.
 The effects of small filament curvature, filament
 diameter, and impact velocity are also discussed.
 The data are used to evaluate the probability of
 penetrations greater than any given depth by fila-
 ments having random orientation.

- I. Nysmith, C. Robert
- II. Summers, James L.
- III. Denardo, B. Pat
- IV. NASA TN D-1981

NASA

NASA TN D-1981
 National Aeronautics and Space Administration.
 INVESTIGATION OF THE IMPACT OF COPPER
 FILAMENTS INTO ALUMINUM TARGETS AT
 VELOCITIES TO 16,000 FEET PER SECOND.
 C. Robert Nysmith, James L. Summers, and
 B. Pat Denardo. February 1964. 10p. OTS price,
 \$0.50. (NASA TECHNICAL NOTE D-1981)

Aluminum targets were impacted by thin copper
 filaments to determine the effect of filament angle
 of inclination upon maximum depth of penetration.
 The effects of small filament curvature, filament
 diameter, and impact velocity are also discussed.
 The data are used to evaluate the probability of
 penetrations greater than any given depth by fila-
 ments having random orientation.

- I. Nysmith, C. Robert
- II. Summers, James L.
- III. Denardo, B. Pat
- IV. NASA TN D-1981

NASA

NASA TN D-1981
 National Aeronautics and Space Administration.
 INVESTIGATION OF THE IMPACT OF COPPER
 FILAMENTS INTO ALUMINUM TARGETS AT
 VELOCITIES TO 16,000 FEET PER SECOND.
 C. Robert Nysmith, James L. Summers, and
 B. Pat Denardo. February 1964. 10p. OTS price,
 \$0.50. (NASA TECHNICAL NOTE D-1981)

Aluminum targets were impacted by thin copper
 filaments to determine the effect of filament angle
 of inclination upon maximum depth of penetration.
 The effects of small filament curvature, filament
 diameter, and impact velocity are also discussed.
 The data are used to evaluate the probability of
 penetrations greater than any given depth by fila-
 ments having random orientation.

- I. Nysmith, C. Robert
- II. Summers, James L.
- III. Denardo, B. Pat
- IV. NASA TN D-1981

NASA