

Lee S... P

NASA TECHNICAL NOTE

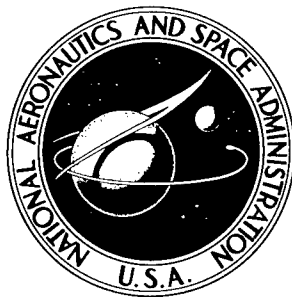

NASA TN D-2495

NASA TN D-2495

PROPERTY OF

Handwritten text, possibly a name or signature, is faintly visible below the 'PROPERTY OF' stamp.

DISTRIBUTION STATEMENT A
Approved for Public Release
Distribution Unlimited

57507

PROGRESS IN SUPERALLOYS

by John C. Freche

*Lewis Research Center
Cleveland, Ohio*

2001129 085

PROGRESS IN SUPERALLOYS

By John C. Freche

Lewis Research Center
Cleveland, Ohio

**Reproduced From
Best Available Copy**

NATIONAL AERONAUTICS AND SPACE ADMINISTRATION

For sale by the Office of Technical Services, Department of Commerce,
Washington, D.C. 20230 -- Price \$0.50

PROGRESS IN SUPERALLOYS

by John C. Freche

Lewis Research Center

SUMMARY

Advanced temperature nickel- and cobalt-base alloys are under development at the NASA Lewis Research Center. The strongest nickel-base alloys developed compare favorably in high-temperature strength with the strongest cast commercial nickel-base alloys and have some workability. The cobalt-base alloys compare well in high-temperature strength with the strongest cast commercial cobalt-base alloys and have good rollability characteristics.

The cobalt-base alloys are unique in that they are strengthened primarily by low-volatility materials, such as the refractory metals. Because of this, they are inherently more resistant to evaporation in a vacuum environment than conventional cobalt-base superalloys that contain large amounts of chromium. This would indicate that, in addition to space-power applications, they might be used advantageously in industrial applications where high-temperature strength and resistance to evaporative loss are major requirements. *Freche*

INTRODUCTION

Superalloys perform a major role in meeting space-age materials requirements in the intermediate temperature range between approximately 1500° and 2200° F. Their high strength at these temperatures coupled with generally good oxidation resistance makes such alloys prime candidates for many aerospace applications. These include turbojet engine stator vanes, turbine buckets, combustion chamber and tailpipe assemblies, and suborbital and space vehicle structural members, to mention a few. *Start* [The NASA is conducting research to develop improved superalloys in order to meet the severe materials requirements imposed by advanced engine and vehicle designs.] Of course, these alloys can be applied in areas other than the aerospace field, and it is expected that industry will benefit from the availability of newer and stronger superalloys.

Research programs are in progress to provide both improved advanced-temperature nickel-base superalloys (refs. 1 to 5), as well as cobalt-base alloys (refs. 6 and 7). [A review of the progress made to date in these research areas is presented.]

NICKEL-BASE ALLOY RESEARCH

The nominal composition in weight percent of the basic NASA nickel-base alloy is given in the following table:

Molybdenum	Chromium	Aluminum	Zirconium	Nickel
8	6	6	1	Balance

This composition was selected for high-temperature strength and ductility from screening studies of various experimental compositions by stress-rupture and tensile tests. It was selected as the basis for further systematic alloying studies utilizing the following elements: carbon, titanium, vanadium, tungsten, and tantalum as well as certain combinations of these elements. All the experimental alloys investigated were induction melted under an inert gas cover. It is significant to note that vacuum casting techniques are not required for these alloys. Experimental melts were approximately 3 pounds in weight, and investment casting techniques were employed to make test specimens.

High-Temperature Strength

By way of an overall summary, figure 1 shows the improvements in 15,000-pound-per-square-inch stress-rupture properties obtained to date by modifications of the basic alloy.

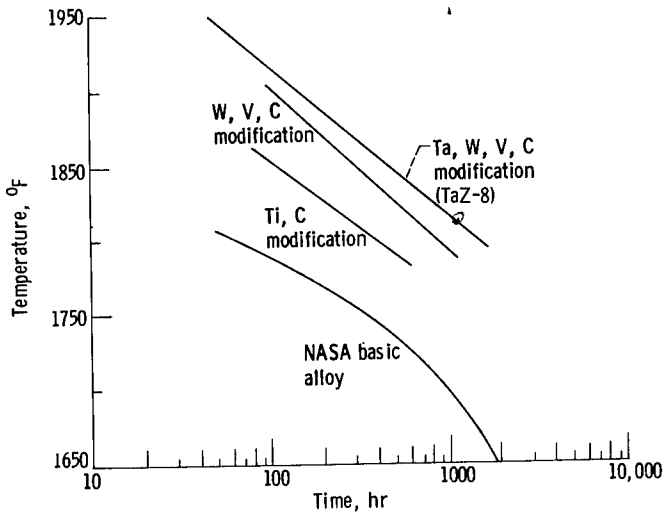

Figure 1. - Stress-rupture comparison of the NASA nickel-base alloy series at stress of 15,000 pounds per square inch.

Successive improvements were made by means of the titanium (Ti), carbon (C) modification, the tungsten (W), vanadium (V), C modification, and the tantalum (Ta), W, V, C modification, also referred to as the NASA TaZ-8 alloy. The extent of the improvements is quite appreciable. Thus, at 1800° F, average life has been extended from less than 100 hours with the basic alloy to approximately 1200 hours with the TaZ-8 alloy. Perhaps even more important has been the increase in use temperature that was obtained. For 100-hour life, for example, 15,000 pound per square inch use temperature has been increased from approximately 1780° F for the basic alloy to 1915° F with the TaZ-8 alloy.

The nominal chemical composition in weight percent of the tantalum-modified nickel-base alloy (NASA TaZ-8) is given in the following table:

Chromium	Aluminum	Molybdenum	Tungsten	Tantalum	Zirconium	Vanadium	Carbon	Nickel
6	6	4	4	8	1	2.5	0.125	Balance

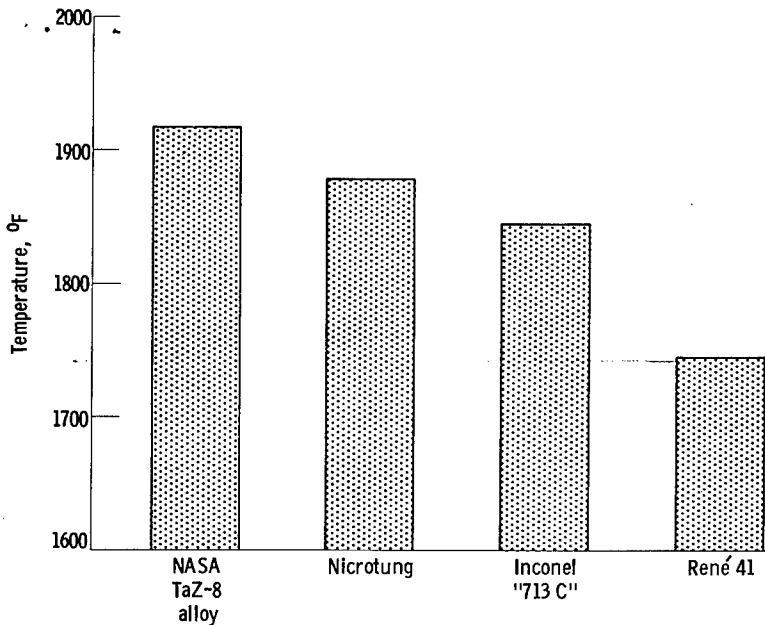

Figure 2. - Operating temperature for 100-hour life at stress of 15,000 pounds per square inch for several nickel-base superalloys.

This composition differs from the basic NASA alloy in that Ta, V, W, and C have been added and the molybdenum (Mo) content reduced.

To provide an indication of how the strongest of these alloys, the TaZ-8 alloy, compares with the strongest commercial nickel-base alloys, a bar-chart comparison of use temperature is given in figure 2. The 100-hour operating temperature at 15,000-pound-per-square-inch stress is presented for the TaZ-8 alloy, for Nicrotung and René 41 (ref. 8), and for Inconel 713C (ref. 9).

René 41 is included as representative of a fully workable nickel-base alloy. The TaZ-8 alloy compares favorably with all of these alloys. Although they are not shown on the figure, more recent commercial alloys, TRW 1800 and IN 100 (ref. 9), also have 100-hour

use temperatures less than that of the TaZ-8 alloy. Recently acquired data for another nickel-base alloy, SM 200 (ref. 10), indicate that its 100-hour use temperature at this stress level is comparable to that of the TaZ-8 alloy. It is important to note, however, that SM 200 is considered by the manufacturer to be a cast product, whereas the TaZ-8 alloy has some workability, as will be shown in the following section.

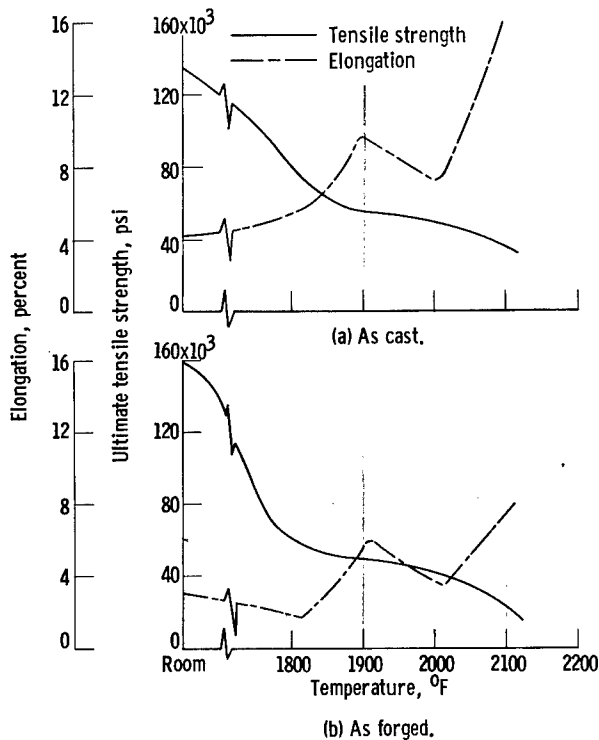

Figure 3. - Tensile properties of NASA TaZ-8 alloy.

Figure 3 shows the tensile properties of TaZ-8 alloy as a function of temperature in both the as-cast and the as-forged condition. In the as-cast condition, ultimate tensile strength ranges from approximately 135,000 pounds per square inch at room temperature to 35,000 pounds per square inch at 2100° F. In the forged condition, ultimate tensile strength varies from 158,000 to 18,000 pounds per square inch at these temperatures. Maximum elonga-

tion values were 16 and 8 percent at 2100° F in the as-cast and as-forged condition, respectively. These elevated temperature tensile strengths are high for nickel-base alloys. At 2000° F, for example, the as-cast ultimate tensile strength of the TaZ-8 alloy exceeds that of any of the unalloyed refractory metals.

Workability

In addition to excellent long time high-temperature-strength properties, this alloy has sufficient ductility so that it has workability potential. With regard to workability, figure 4 shows the degree of deformation achieved at

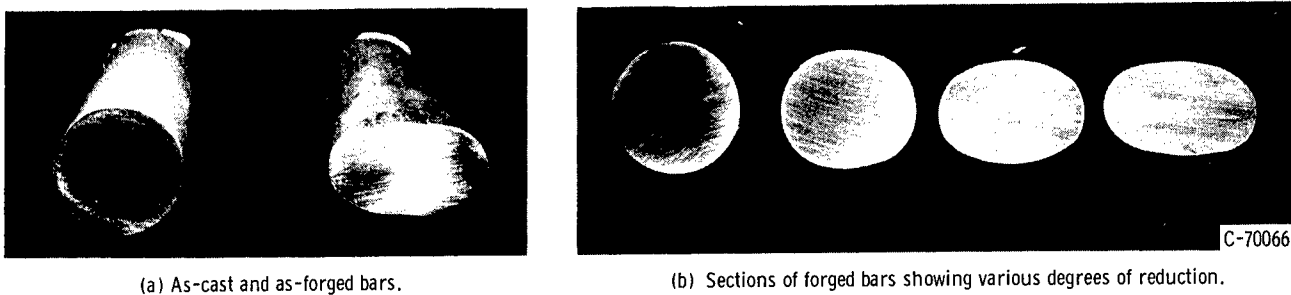

Figure 4. - Deformation of cold-forged bars of NASA TaZ-8 alloy.

room temperature in a 4500-pound drop forge with a 1/2-inch-diameter cast round of the TaZ-8 alloy. Reductions in thickness of 29 percent, as shown here, have been obtained without edge cracking. These results indicate that the alloy has a considerable degree of ductility. Superstrength sheet has also been obtained from this alloy. This work was done under Air Force sponsorship by another investigator (ref. 11). Cast slabs of the TaZ-8 alloy that were 0.100 inch thick were successfully reduced to 0.015-inch-thick sheets by using specialized rolling equipment.

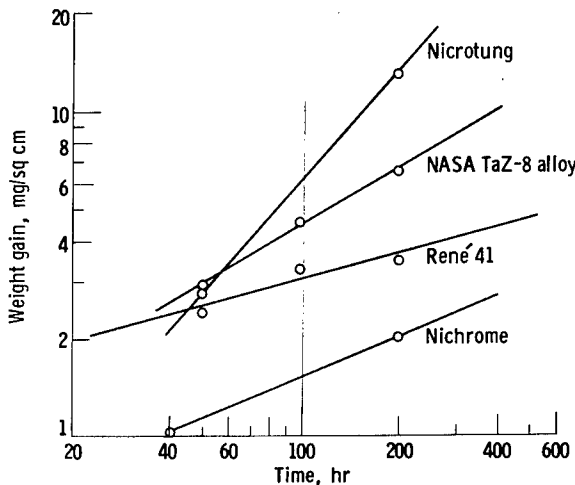

Figure 5. - Oxidation data for several nickel-base alloys at 1900° F.

Oxidation Resistance

In addition to good workability and high short-time, elevated-temperature strength, good oxidation resistance at high temperatures is also required from nickel-base alloys, particularly for reentry vehicle applications. Figure 5 compares the 1900° F oxidation resistance on the basis of weight gain per unit area of the NASA TaZ-8 alloy with René 41, presently a leading contender for reentry vehicle skin panels. Also shown in figure 5 are data for Nicrotung, a strong cast nickel-base alloy, and Nichrome, a very weak material with

excellent oxidation resistance, which is included here as a frame of reference. The TaZ-8 alloy shows a weight gain per unit area intermediate to Microtung and René 41, which indicates oxidation characteristics more favorable than Microtung but less favorable than René 41.

Some spalling of the oxide scales was observed with all of these alloys, but it was more pronounced with the TaZ-8 alloy. Spalling of the oxide is particularly undesirable for thin panel sections of reentry vehicles since it continually exposes a fresh metal surface to the oxidizing environment. This can adversely affect the structural integrity of such a thin section.

Metallographic studies indicate another aspect of the oxidation problem with these alloys that is of importance. Figure 6 shows the microstructures of

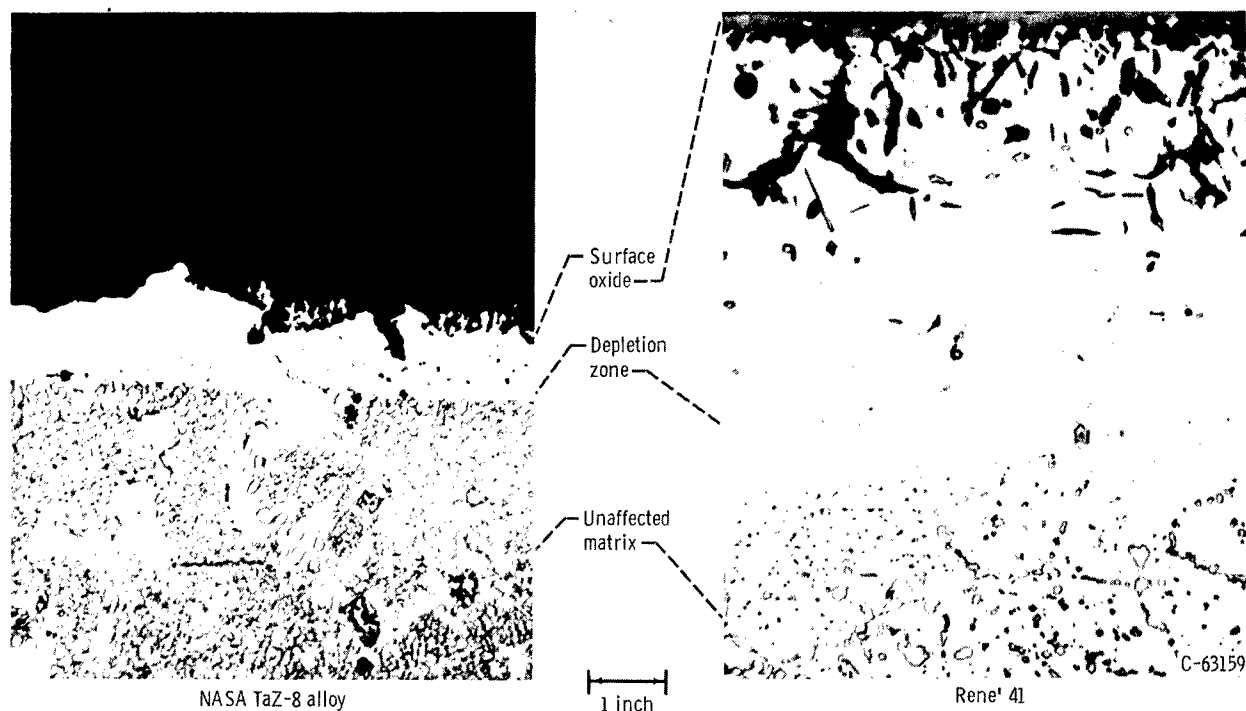

Figure 6. - Microstructure of oxidation test specimens after 200 hours at 1900° F. X750.

oxidized samples of TaZ-8 and René 41. Both alloys display an external oxide layer, a depletion zone adjacent to the oxidized surface, and a relatively unaffected zone. The depth of depletion zone is appreciably less for TaZ-8, however. This implies that TaZ-8 may be less subject to structural deterioration as a result of depletion of alloying constituents upon exposure to high-temperature oxidizing conditions, even though it is more subject to spalling than René 41.

Various modifications of the NASA TaZ-8 alloy are under investigation to improve its high-temperature oxidation resistance as well as its high-temperature strength. Some preliminary oxidation data obtained at 1900° F with one of the most promising modifications are shown in figure 7 compared with the TaZ-8 alloy and with René 41 on a weight gain per unit area basis. The modified

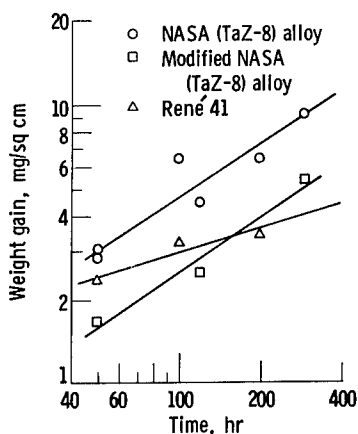

Figure 7. - Oxidation behavior of several nickel-base alloys at 1900° F.

NASA TaZ-8 alloy shows a lower weight gain per unit area than René 41 up to approximately 200 hours but a greater gain beyond 200 hours. It is of interest to note that the spalling observed previously with the TaZ-8 alloy appears to have been virtually eliminated with the modified alloy, and that it was significantly less than that observed with René 41. The high-temperature properties and workability of this modified alloy are now being investigated, and preliminary data indicate that these properties are at least as good as those of the TaZ-8 alloy.

Applications

[A major area of interest for nickel-base superalloys is in turbojet engine applications.] Figure 8 shows the results of some jet engine tests made with one of the earlier alloys in this series, a Ti,C modification of the basic alloy.

This alloy was evaluated as a turbine rotor bucket material along with several commercial superalloys in a modified J33-9 engine. Turbine inlet

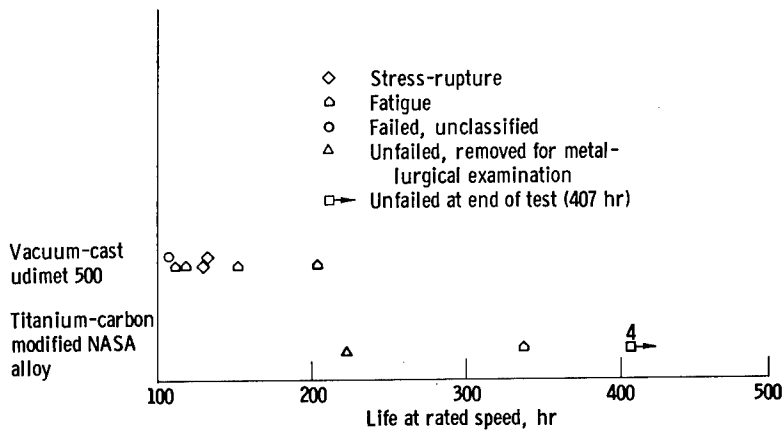

Figure 8. - Results of alloy evaluation in turbojet engine. Bucket temperature, 1650°.

gas temperature was 1800° F and the maximum bucket temperature was 1650° F. It is significant to note that these temperatures are approximately 100° F or more above those currently employed in commercial turbojet engines. As buckets failed or were severely damaged during the course of the test, which was conducted at rated engine speed, they were replaced with new ones. [The results obtained with this alloy are compared with those of cast Udimet 500.] After 407 hours, four of the original six NASA alloy buckets remained intact. One was removed for metallographic examination after 223 hours, and another failed in fatigue after 340 hours. The later alloys of this series have better high-temperature strength and ductility than the Ti,C modified alloy. This suggests that they should also perform more favorably as turbine buckets at inlet gas temperatures of 1800° F and above.

[Another interesting application for these alloys now under consideration is in suborbital flight vehicles such as the NASA X-15 airplane] shown in figure 9. As the X-15 descends through the Earth's atmosphere, the temperatures of many parts of this airplane assume values at which material strength deterio-

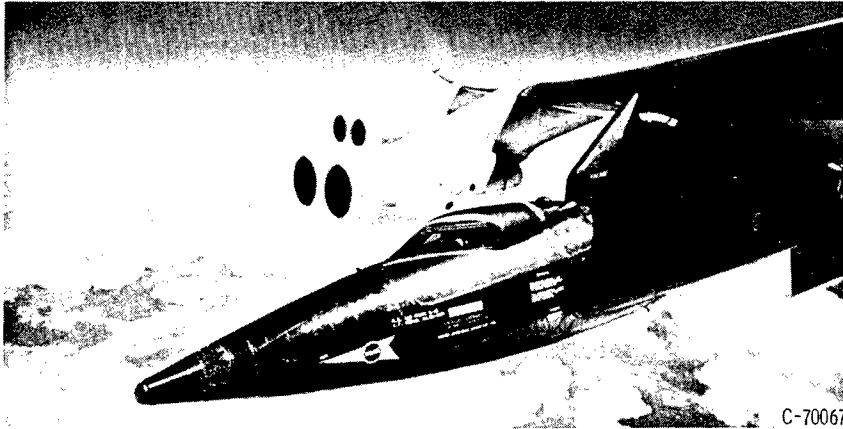

Figure 9. - NASA X-15 airplane.

rates markedly. One such area is the nose sensor. Figure 10 illustrates an investment cast blank of the nose sensor (instrument housing) cast from one of the NASA alloys for an advanced version of this airplane. This will be machined to the final shape shown adjacent to it.



Figure 10. - Nose instrument housing of X-15 airplane.

These two illustrative applications are, of course, directly related to the aerospace field, which is the area of immediate NASA interest. It should be reiterated, however, that these alloys have potential for use in any engineering application where high-temperature strength and ductility are required at temperatures up to perhaps 2100° F.

COBALT-BASE ALLOY RESEARCH

Research is also being conducted to provide advanced temperature cobalt-base alloys primarily for application to advanced space-power systems. Fig-

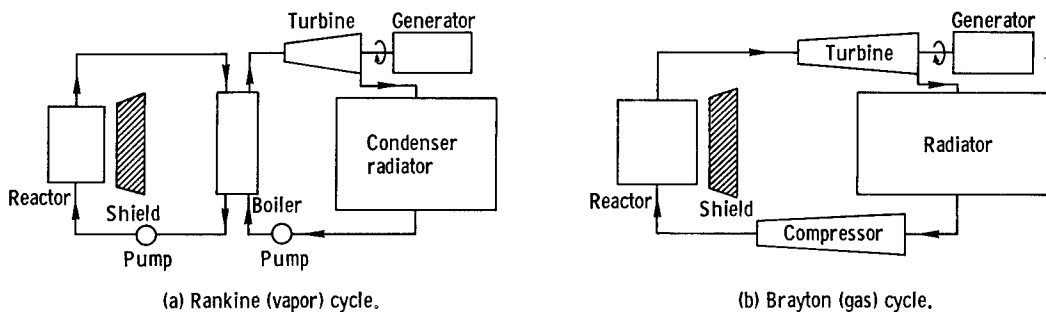

Figure 11. - Nuclear turbogenerator systems.

ure 11 illustrates two promising systems of this type. The figure shows schematic diagrams of two turboelectric power systems in which nuclear power is converted to electric power through the medium of closed thermodynamic cycles. Both a Rankine and a Brayton cycle are shown. In both systems heat energy is supplied by a nuclear reactor. A heat-transfer fluid is used to extract heat from the reactor and drive a turbogenerator. The major differences between the two systems lie in the fact that the Rankine cycle employs a dual loop and uses liquid-metal heat-transfer and turbine drive fluids, whereas the Brayton cycle employs a single loop and an inert gas as the heat-transfer and turbine drive fluid.

For systems of this type, alloys with superior properties are needed for radiator, ducting, turbine, and generator components. Because these must in many cases function in an intermediate temperature range between approximately 1500° and 2200° F, superalloys are prime contenders for use in these components. Cobalt-base alloys are of particular interest if a liquid metal is used as the heat-transfer fluid (Rankine cycle). Extensive corrosion studies made with mercury up to 1300° F for times up to 1000 hours have shown nickel-free cobalt-base alloys to be superior to nickel-base and nickel-bearing cobalt-base alloys, although inferior to refractory metals (ref. 12). Only limited corrosion data are available to date with the alkali metals, and extensive research is still required to establish fully the relative merits of various materials with respect to alkali metal corrosion. The alkali metals are, of course, also under consideration for use in these space-power systems. Also, cobalt has a somewhat lower evaporative loss rate than nickel.

The importance of low volatility in materials to be used in a space environment can better be understood by consideration of figure 12, which shows the loss rates of various metals as a function of temperature in inches per 10,000 hours. This period of time is approximately equivalent to an interplanetary mission of 1 year. These data were compiled from reference 13. Only Ti, C, Zr, and the refractory metals have lower loss rates than cobalt. Both aluminum (Al) and chromium (Cr) have high loss rates. Perhaps most significant is the high evaporative loss rate of Cr, which is present in quantities up to 25 percent in virtually all commercial cobalt-base alloys. For example, at 1800° F, Cr has an evaporation loss rate of 0.030 inch in 10,000 hours, which is clearly undesirable for thin wall tubing applications. Of course, these calculations were made for pure metals, and dilution and other effects will probably exist in the case of alloys.

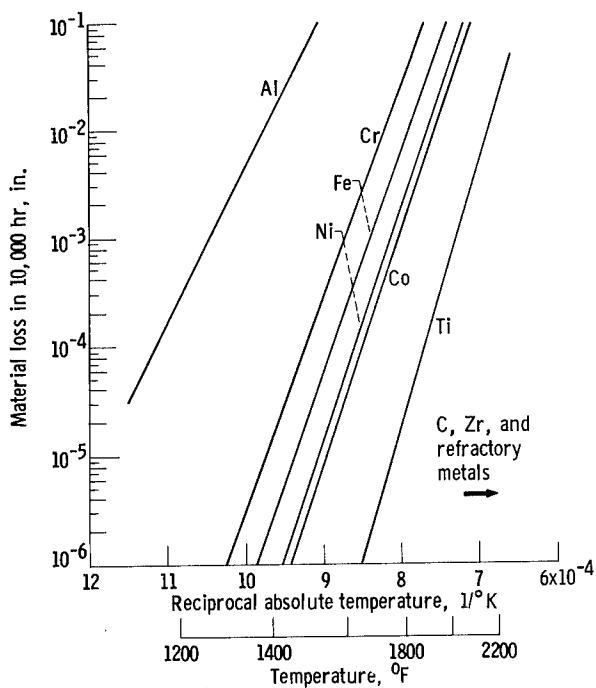

Figure 12. - Vaporization loss of various metals.

Nevertheless, it appears from the magnitude of these losses that evaporation of volatile alloying constituents cannot safely be ignored and that structural de-

terioration could occur with alloys containing large quantities of Cr, upon their exposure for long time periods at high temperature in a space environment.

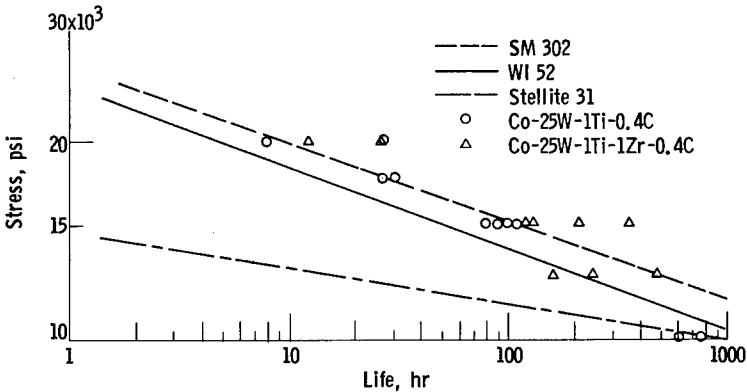

Figure 13. - Comparison of stress-rupture properties at 1800° F of several cast cobalt-base alloys.

base alloys which are strengthened primarily by low volatility alloying constituents for advanced space-power-system applications. Experimental compositions of cobalt - refractory-metal alloys were screened for high-temperature strength and ductility by stress-rupture and tensile tests. A ternary alloy, Co-25W-1Ti, was selected as the basis for further systematic alloying studies utilizing low-volatility additives. All alloys were induction melted under an inert gas cover. Vacuum melting is not required for these alloys. Melts were approximately 3 pounds in size and investment casting techniques were used to make test specimens.

High-Temperature Strength

Figure 13 illustrates the as-cast 1800° F stress-rupture properties in air of two of the strongest alloys developed thus far, a 0.4C modified alloy and the 0.4C,1Zr modified alloy, compared with several of the strongest current cast cobalt-base alloys ~~SM 302 and Stellite 31~~ (ref. 15), and ~~WI-52~~ (ref. 16). It is evident that, although no attempts were made to protect the experimental alloys against oxidation by coatings, the lives of these alloys compare favorably with those of the commercial alloys, all of which contain between 21 and 25 percent Cr.

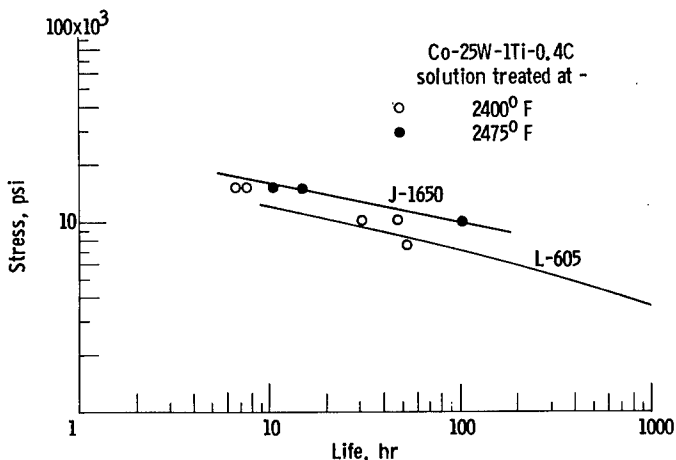

Figure 14. - Stress-rupture properties at 1800° F of Co-25W-1Ti-0.4C alloy sheet in helium and current sheet alloys in air.

Some recent data by Russian investigators (ref. 14) have come to light which suggest that there may be a point of controversy as to the relative evaporative loss rates of metals such as cobalt and nickel. Until further data are obtained, the data referenced herein represent the most complete and accepted data on this subject and must form the basis for any comparisons of this nature.

An investigation is being conducted to provide advanced temperature cobalt-

base alloys compared with several of the strongest current cast cobalt-base alloys ~~SM 302 and Stellite 31~~ (ref. 15), and ~~WI-52~~ (ref. 16). It is evident that, although no attempts were made to protect the experimental alloys against oxidation by coatings, the lives of these alloys compare favorably with those of the commercial alloys, all of which contain between 21 and 25 percent Cr.

Some ^{CoB} stress-rupture data have also been obtained with sheet material of the 0.4C modified alloy. Figure 14 illustrates the

1800° F sheet stress-rupture properties of this alloy compared with those of two of the strongest current cobalt-base sheet alloys, J-1650 (ref. 15) and L-605 also known as Haynes Alloy 25 (ref. 17). To avoid loss of load bearing area by oxidation, the small cobalt - refractory-metal alloy sheet (0.060-in.) specimens were tested in helium. Although only limited data have been obtained to date, these data compare quite well with the commercial alloys. Solution treatments were the only heat treatments attempted with the experimental alloy. It is probable that its properties could be improved by suitable aging or combinations of working and aging. Sheet specimens will be tested in vacuum to simulate space conditions more closely.

The ^{CoB} tensile properties of the 0.4C and the 0.4C - 1Zr modified alloys are summarized in the following table:

Alloy	Condition	Test temperature, °F	Ultimate tensile strength, psi	Elongation, percent
Cast				
Co-25W-1Ti-0.4C	As-cast	Room	97,000	6.2
		1800	44,870	12.5
Co-25W-1Ti-1Zr-0.4C	As-cast	Room	98,580	3.5
Sheet				
Co-25W-1Ti-0.4C ↓	As-rolled	Room	204,400	22.6
	Solution treated at 2475° F	Room	106,000	14.4
	Solution treated at 2400° F	Room	144,250	20.3
	Solution treated at 2400° F	1800	34,800	15.5
Co-25W-1Ti-1Zr-0.4C ↓	As-rolled	Room	179,300	20.2
	Solution treated at 2400° F	Room	147,030	20.5
	Solution treated at 2400° F	1800	38,250	19.5

Both as-cast and sheet data are shown. Several points should be noted with respect to these data. The elongations range between approximately 15 and 22 percent for the sheet material. The as-hot-rolled room-temperature tensile strengths exceed 200,000 pounds per square inch. The latter fact may be of considerable interest for room-temperature applications where high-strength sheet is required. Still higher strengths are probably obtainable by cold rolling. These alloys thus afford a combination of high-elevated-temperature and room-temperature strength.

Further alloying investigations are being conducted to extend further the high-temperature strength capability of this family of alloys.]

Workability

Since good workability is another major requirement for advanced power system ducting and radiator applications, attempts were made to form the strongest cobalt - refractory-metal alloys into sheet. [The alloys were readily rollable.] This is illustrated pictorially in figure 15, which shows a chill-cast slab of the Co-25W-1Ti-1Zr-0.4C alloy approximately 2 by

$2\frac{1}{2}$ inches and $\frac{1}{2}$ inch thick.

The 0.045-inch sheet adjacent to it was obtained by hot rolling at 2150° F, and no edge cracking was observed. On the right is a section of a 0.045-inch-thick sheet that was further reduced to a thickness of 0.013 inch by cold rolling.

The ease with which these alloys can be rolled suggests that they can be formed into the complex shapes required for radiator and ducting components of advanced space-

power systems and used for other high-temperature aerospace applications as well.

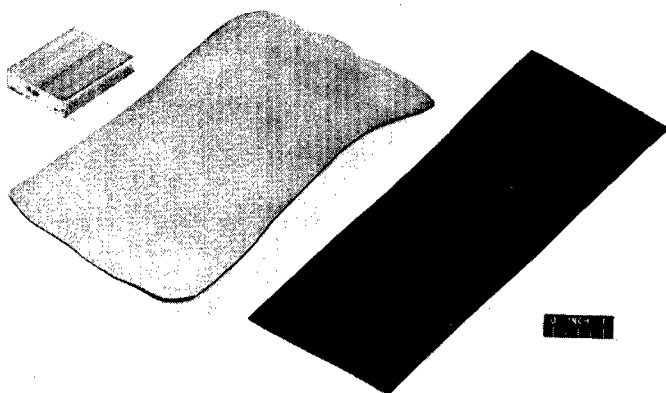

C-66228

Figure 15. - Steps in rolling alloy Co-25W-1Ti-1Zr-0.4C.

Oxidation Resistance

[Although the cobalt - refractory-metal alloys] ^{Cap} under investigation [cannot be expected to have the same high degree of oxidation resistance observed in high Cr bearing superalloys, it was found that these alloys certainly do not oxidize catastrophically. On the contrary, their long life in air in high-temperature stress-rupture tests suggests that these alloys have at least limited applicability in the uncoated condition in an oxidizing environment. Of course, in space-power-system applications where a vacuum environment is involved, oxidation is not a problem. By providing protective coatings, the potential of these alloys is further enhanced for a variety of other high-temperature applications including turbojet engine components, such as stator vanes, turbine buckets, combustor, and tailpipe components.]

CONCLUDING REMARKS

[In view of the potential of these nickel- and cobalt-base alloys for high-temperature aerospace applications, research is continuing to extend their high-temperature capability. Although these alloys were developed for aero-]

space applications, their advantageous properties suggest that they be considered for appropriate high-temperature industrial applications as well. *end*

Lewis Research Center
National Aeronautics and Space Administration
Cleveland, Ohio, June 24, 1964

REFERENCES

1. Freche, John C., and Waters, William J.: Exploratory Investigation of Advanced-Temperature Nickel-Base Alloys. NASA MEMO 4-13-59E, 1959.
2. Freche, John C., Riley, Thomas J., and Waters, William J.: Continued Study of Advanced-Temperature Nickel-Base Alloys to Investigate Vanadium Additives. NASA TN D-260, 1960.
3. Freche, John C., Waters, William J., and Riley, Thomas J.: A New Series of Nickel-Base Alloys for Advanced-Temperature Applications. Trans. ASM, vol. 53, 1961, pp. 523-537.
4. Freche, J. C., Waters, W. J., and Riley, T. J.: A New Series of Advanced-Temperature Nickel-Base Alloys. High Temperature Materials - II, G. M. Ault, ed., Interscience Pub., 1963, pp. 215-228.
5. Freche, John C., and Waters, William J.: Continued Investigation of an Advanced-Temperature, Tantalum-Modified, Nickel-Base Alloy. NASA TN D-1531, 1963.
6. Freche, John C., Ashbrook, Richard L., and Klima, Stanley J.: Cobalt-Base Alloy for Space-Power Systems. Jour. Metals, vol. 15, no. 12, Dec. 1963, pp. 928-934.
7. Freche, John C., Ashbrook, Richard L., and Klima, Stanley J.: A New Series of Cobalt - Refractory-Metal Alloys for Advanced Space Power Systems. Cobalt, no. 20, Sept. 1963, pp. 114-116.
8. Wagner, H. J.: Recent Developments in Superalloys. DMIC Memo. 64, Defense Metals Info. Center, Sept. 8, 1960, p. 9.
9. Lund, C. H.: The Use of Nickel-Base Alloys in the Rotating Parts of Gas Turbines for Aerospace Applications. DMIC Memo. 145, Defense Metals Info. Center, Jan. 11, 1962, p. 18.
10. Anon.: SM 200 - High Temperature Nickel Base Superalloy. Martin Metals Co.
11. Greenewald, H., Jr., and Riley, T. J.: Development of a Nickel Base Alloy Sheet for High Temperature Application. Rep. ASD-TDR-62-869, Mar. 15, 1961-July 15, 1962, Wright-Patterson Air Force Base, Apr. 1963.

12. Scheuermann, C. M., Barrett, C. A., Lowdermilk, W. H., and Rosenblum, Louis: Snap-8 Materials. *Astronautics and Aerospace Eng.*, vol. 1, no. 11, Dec. 1963, pp. 40-43.
13. Dushman, Saul: *Scientific Foundations of Vacuum Technique*. Second ed., John Wiley & Sons, Inc., 1962. *Out Catalog*
14. Nesmeyanov, A. N.: *Vapor Pressure of the Elements*. Academic Press, N. Y., 1963. *Ref Book*
15. Wagner, H. J., and Hall, A. M.: *The Physical Metallurgy of Cobalt-Base Superalloys*. DMIC Rep. 171, Defense Metals Info. Center, July 6, 1962, pp. 39;70.
16. Morral, F. R., and Wagner, H. J.: *Physical and Mechanical Properties of the Cobalt-Chromium-Tungsten Alloy WI-52*. DMIC Memo. 66, Defense Metals Info. Center, Sept. 22, 1960, p. 9.
17. Anon.: *Haynes Alloy Number 25*. Haynes Stellite Co., June 62.

NASA TN D-2495
National Aeronautics and Space Administration.
PROGRESS IN SUPERALLOYS. John C. Freche.
October 1964. 13p. OTS price, \$0.50.
(NASA TECHNICAL NOTE D-2495)

Advanced temperature nickel- and cobalt-base alloys are under development at the NASA Lewis Research Center. The strongest nickel-base alloys developed compare favorably in high-temperature strength with the strongest cast commercial nickel-base alloys and have some workability. The cobalt-base alloys compare well in high-temperature strength with the strongest cast commercial cobalt-base alloys and have good rollability characteristics.

I. Freche, John C.
II. NASA TN D-2495

NASA

NASA TN D-2495
National Aeronautics and Space Administration.
PROGRESS IN SUPERALLOYS. John C. Freche.
October 1964. 13p. OTS price, \$0.50.
(NASA TECHNICAL NOTE D-2495)

Advanced temperature nickel- and cobalt-base alloys are under development at the NASA Lewis Research Center. The strongest nickel-base alloys developed compare favorably in high-temperature strength with the strongest cast commercial nickel-base alloys and have some workability. The cobalt-base alloys compare well in high-temperature strength with the strongest cast commercial cobalt-base alloys and have good rollability characteristics.

I. Freche, John C.
II. NASA TN D-2495

NASA

NASA TN D-2495
National Aeronautics and Space Administration.
PROGRESS IN SUPERALLOYS. John C. Freche.
October 1964. 13p. OTS price, \$0.50.
(NASA TECHNICAL NOTE D-2495)

Advanced temperature nickel- and cobalt-base alloys are under development at the NASA Lewis Research Center. The strongest nickel-base alloys developed compare favorably in high-temperature strength with the strongest cast commercial nickel-base alloys and have some workability. The cobalt-base alloys compare well in high-temperature strength with the strongest cast commercial cobalt-base alloys and have good rollability characteristics.

I. Freche, John C.
II. NASA TN D-2495

NASA

NASA TN D-2495
National Aeronautics and Space Administration.
PROGRESS IN SUPERALLOYS. John C. Freche.
October 1964. 13p. OTS price, \$0.50.
(NASA TECHNICAL NOTE D-2495)

Advanced temperature nickel- and cobalt-base alloys are under development at the NASA Lewis Research Center. The strongest nickel-base alloys developed compare favorably in high-temperature strength with the strongest cast commercial nickel-base alloys and have some workability. The cobalt-base alloys compare well in high-temperature strength with the strongest cast commercial cobalt-base alloys and have good rollability characteristics.

I. Freche, John C.
II. NASA TN D-2495

NASA

NASA TN D-2495
National Aeronautics and Space Administration.
PROGRESS IN SUPERALLOYS. John C. Freche.
October 1964. 13p. OTS price, \$0.50.
(NASA TECHNICAL NOTE D-2495)

Advanced temperature nickel- and cobalt-base alloys are under development at the NASA Lewis Research Center. The strongest nickel-base alloys developed compare favorably in high-temperature strength with the strongest cast commercial nickel-base alloys and have some workability. The cobalt-base alloys compare well in high-temperature strength with the strongest cast commercial cobalt-base alloys and have good rollability characteristics.

I. Freche, John C.
II. NASA TN D-2495

NASA

NASA TN D-2495
National Aeronautics and Space Administration.
PROGRESS IN SUPERALLOYS. John C. Freche.
October 1964. 13p. OTS price, \$0.50.
(NASA TECHNICAL NOTE D-2495)

Advanced temperature nickel- and cobalt-base alloys are under development at the NASA Lewis Research Center. The strongest nickel-base alloys developed compare favorably in high-temperature strength with the strongest cast commercial nickel-base alloys and have some workability. The cobalt-base alloys compare well in high-temperature strength with the strongest cast commercial cobalt-base alloys and have good rollability characteristics.

I. Freche, John C.
II. NASA TN D-2495

NASA

"The aeronautical and space activities of the United States shall be conducted so as to contribute . . . to the expansion of human knowledge of phenomena in the atmosphere and space. The Administration shall provide for the widest practicable and appropriate dissemination of information concerning its activities and the results thereof."

—NATIONAL AERONAUTICS AND SPACE ACT OF 1958

NASA SCIENTIFIC AND TECHNICAL PUBLICATIONS

TECHNICAL REPORTS: Scientific and technical information considered important, complete, and a lasting contribution to existing knowledge.

TECHNICAL NOTES: Information less broad in scope but nevertheless of importance as a contribution to existing knowledge.

TECHNICAL MEMORANDUMS: Information receiving limited distribution because of preliminary data, security classification, or other reasons.

CONTRACTOR REPORTS: Technical information generated in connection with a NASA contract or grant and released under NASA auspices.

TECHNICAL TRANSLATIONS: Information published in a foreign language considered to merit NASA distribution in English.

TECHNICAL REPRINTS: Information derived from NASA activities and initially published in the form of journal articles.

SPECIAL PUBLICATIONS: Information derived from or of value to NASA activities but not necessarily reporting the results of individual NASA-programmed scientific efforts. Publications include conference proceedings, monographs, data compilations, handbooks, sourcebooks, and special bibliographies.

Details on the availability of these publications may be obtained from:

SCIENTIFIC AND TECHNICAL INFORMATION DIVISION
NATIONAL AERONAUTICS AND SPACE ADMINISTRATION
Washington, D.C. 20546