

P

NASA TECHNICAL NOTE

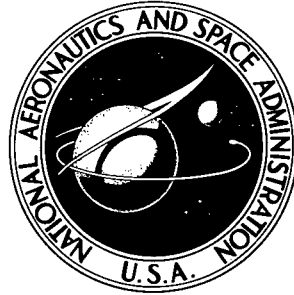

NASA TN D-2814

NASA TN D-2814

AMPTIAC

60290

DISTRIBUTION STATEMENT A
Approved for Public Release
Distribution Unlimited

OR

COLLAPSE TESTS OF PRESSURIZED
MEMBRANE-LIKE CIRCULAR CYLINDERS
FOR COMBINED COMPRESSION AND BENDING

by Walter J. Leumont, Jr.
Langley Research Center
Langley Station, Hampton, Va.

20011129 124

NASA TN D-2814

COLLAPSE TESTS OF PRESSURIZED
MEMBRANE-LIKE CIRCULAR CYLINDERS FOR COMBINED
COMPRESSION AND BENDING

By Walter J. Leumont, Jr.

Langley Research Center
Langley Station, Hampton, Va.

**Reproduced From
Best Available Copy**

NATIONAL AERONAUTICS AND SPACE ADMINISTRATION

For sale by the Clearinghouse for Federal Scientific and Technical Information
Springfield, Virginia 22151 - Price \$1.00

COLLAPSE TESTS OF PRESSURIZED
MEMBRANE-LIKE CIRCULAR CYLINDERS FOR COMBINED
COMPRESSION AND BENDING

By Walter J. Leumont, Jr.
Langley Research Center

SUMMARY

Experimental collapse loads are presented for combined compression and bending of internally pressurized membrane-like cylinders with a length-radius ratio of three and with large values of radius-thickness ratio. The results show a linear relationship of compressive loads and bending moments for collapse of cylinders of length such that column-bending effects are negligible.

INTRODUCTION

The postbuckling behavior of internally pressurized cylinders subjected to bending moments and compressive loads has been viewed from a membrane-theory approach (refs. 1 and 2). These studies indicated a need for experimental data for internally pressurized cylinders subjected to combined bending and compression and designed to be well into the range of membrane behavior. Accordingly, the data were obtained by testing cylinders made of thin polyester film and the results are presented herein. Cylinders with radius-thickness ratios of 3000, 6000, and 12 000 were tested at internal pressures so that data well into the range of membrane behavior were obtained.

SYMBOLS

The units used for the physical quantities defined in this section are given both in the U.S. Customary units and in the International System of Units (SI). Factors relating the two systems are given in reference 3.

- P compressive load at collapse of cylinder, pounds (newtons)
- P_0 applied compressive load causing collapse in absence of bending loads, pounds (newtons)
- P'_0 theoretical collapse load, $p\pi r^2 + 1.2\pi Et^2$, pounds (newtons)

E	Young's modulus, pounds/inch ² (newtons/meter ²)
l	length of cylinder between end plates, inches (meters)
M	bending moment at collapse of cylinder, inch-pounds (meter-newtons)
M ₀	applied bending moment causing collapse in absence of compressive loads, inch-pounds (meter-newtons)
M' ₀	theoretical collapse moment, $p\pi r^3$, inch-pounds (meter-newtons)
r	radius of cylinder, inches (meters)
p	internal hydrostatic pressure, pounds/inch ² (newtons/meter ²)
p*	pressure parameter (ref. 1), $[12(1 - \mu^2)]^{1/2} \left(\frac{p}{E}\right)\left(\frac{r}{t}\right)^2$
t	thickness of wall material, inch (meter)
μ	Poisson's ratio

TEST SPECIMENS AND PROCEDURES

The general configuration and dimensions of the test cylinders are shown in figure 1 and table I. The radius-thickness ratios of the cylinders were 3000, 6000, and 12 000; all cylinders had the same length-radius ratio, that is, l/r of 3.0. The cylinder walls of transparent plastic [polyethylene terephthalate] film were fabricated with the rolled direction in the longitudinal direction. Two diametrically opposed, 0.5-inch (1.27-cm) lap seams, parallel to the longitudinal axis, were positioned along the neutral axis of each specimen. After cutting the material for the proper circumferential dimension, the two seams were bonded. The cylindrical shape was then slipped over a long machine-finished mandrel for attachment of the split end rings. (See fig. 1.) While the plastic film was on the mandrel, the split rings were positioned and bonded to the cylinder wall. Excess film was then trimmed from the ends leaving 0.5 inch (1.27 cm) of film to be notched, turned back, and bonded to the face of the rings. All bonds were made with a synthetic elastomeric adhesive. Finally, following removal of the mandrel, the end plates with attached gaskets were bolted to the end rings and thus sealed the pressure vessel. End plate details are shown in figure 1.

The test setup is shown in figure 2. The suspension system was arranged to permit many degrees of freedom. Wherever rotations occurred, knife edges of hardened steel were used to minimize the effects of friction. Dead loads applied slowly provided all loading conditions. Compressive loading was accomplished by restraining, although not fixing, one end plate and pulling the opposite end plate toward the restrained end. The restrained end plate was

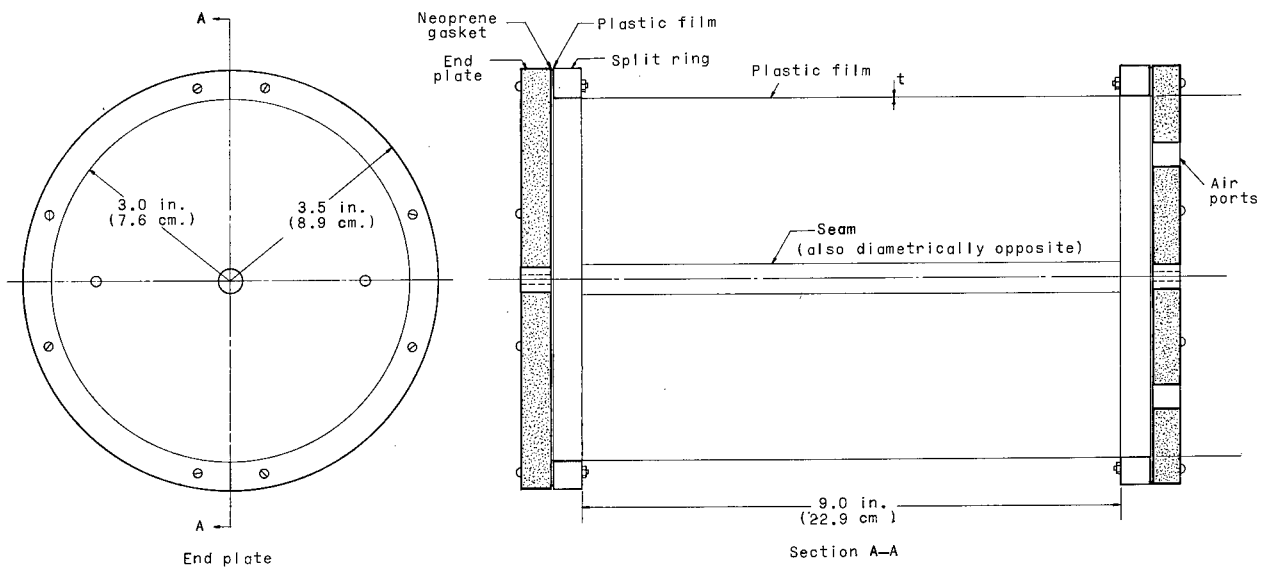

Figure 1. - Details of plastic film cylinders.

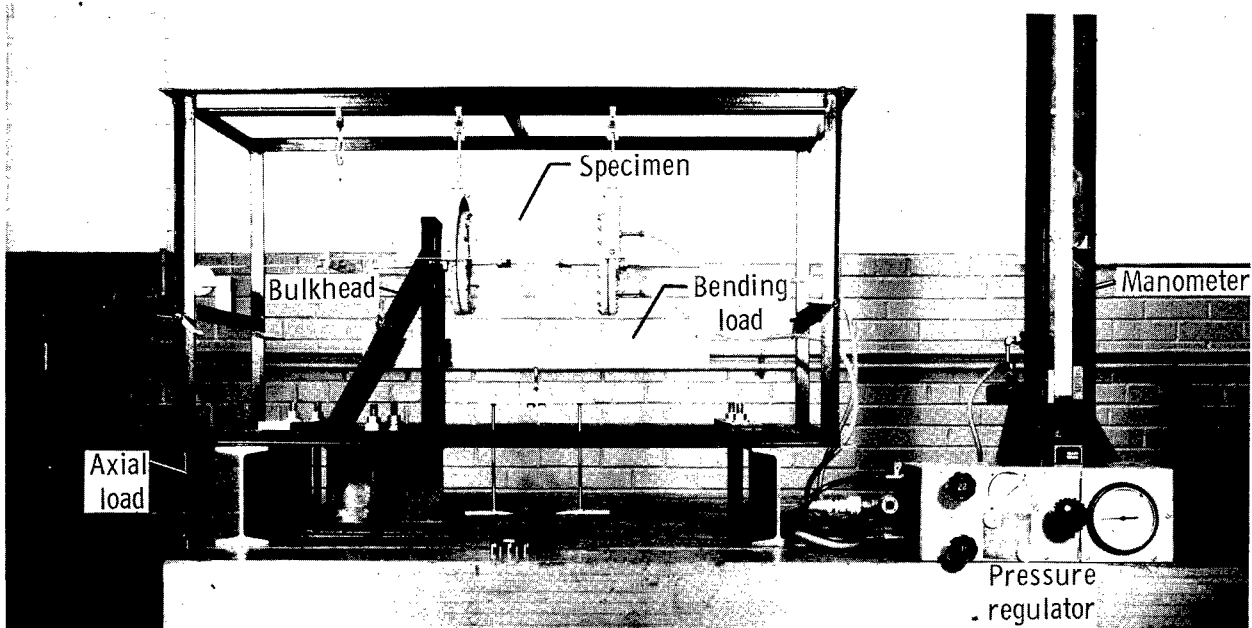

Figure 2. - General view of test setup.

L-63-1972.1

free to rotate about the neutral axis but was not free to translate. Pure bending was introduced into the specimen by placing a load at a fixed eccentricity from the center of rotation of the end fixture; transverse shear forces due to the eccentric load were counteracted by the end suspension system. Hence, combined loadings were introduced into the cylinder wall by relative rotation and translation of the end plates. A detailed view of the suspension and load application systems is shown in figure 3. Prior to attaching the cylinder onto the end plates, all weights resulting from attached fixtures (loading bar, pressure lines, end plates) were counterbalanced to eliminate the introduction of extraneous bending loads. The specimens were pressurized by a constant slow rate of flow of air through the cylinder throughout the duration of the testing to permit small volume changes without a corresponding pressure change. Pressure was controlled by a conventional pressure regulator with fine adjustment valves and monitored with a water manometer. The internal pressure loaded the cylinder hydrostatically; that is, the pressure load on the ends of the cylinder was carried by the walls of the cylinder not by the test fixtures. The pressures were such that at least four discrete values of the parameter p^* were investigated within each of the three r/t groups. Experimental compressive strength P_0 (zero bending moment), and experimental bending strength M_0 (zero compressive load), were determined for these values of p^* . In the combined-load tests a minimum of five values of axial compression were successively applied. The axial compression ranged from 8 to 94 percent of the

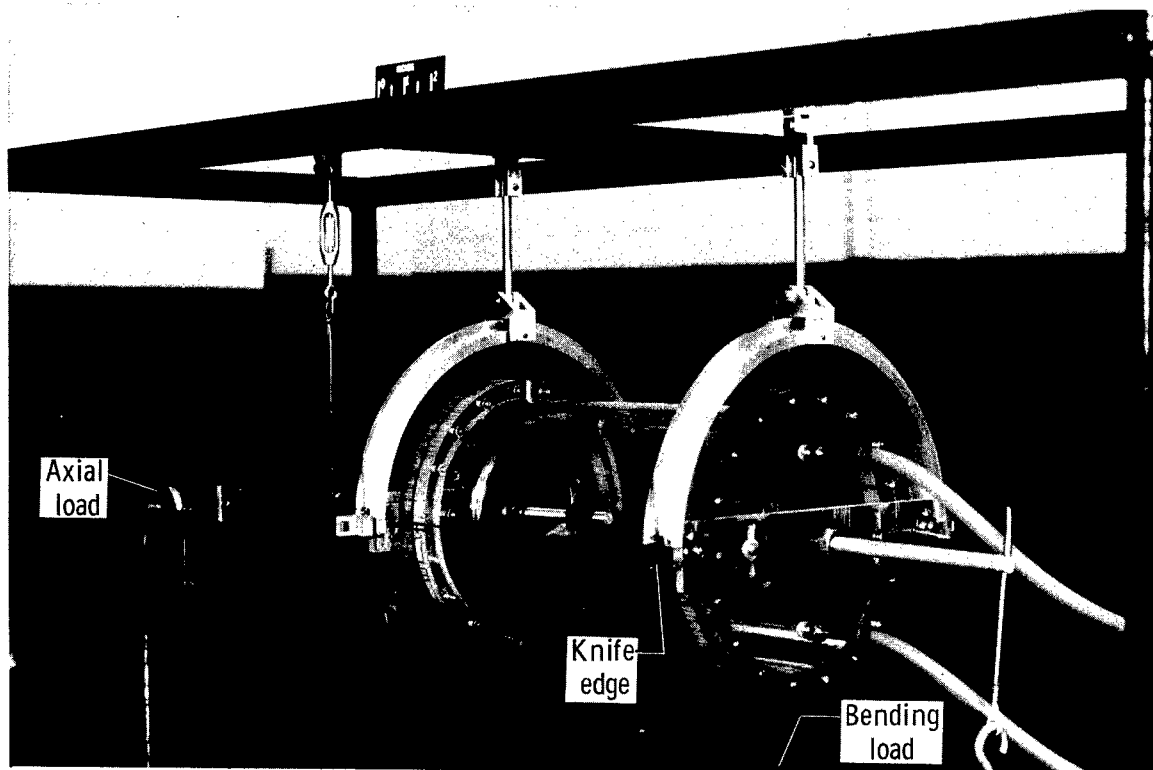

Figure 3. - Details of test setup.

L-63-1971.1

compressive load required to buckle the cylinder in the absence of bending moments. The test procedure consisted of subjecting the cylinder to a particular pressure followed by the prescribed compressive load. Bending moments were then applied and were increased in small increments until the deflection would not stabilize but continued to grow without the application of an additional bending moment. This point was defined as collapse. Collapse was never severe enough to cause rupture of the specimen. However, deformations observed as the specimen approached failure were excessive. Deep wrinkling encompassing approximately 75 percent of the circumference and center-line deflections approaching 1/2 inch (1.3 cm) were not uncommon. Particular care was taken to inspect the specimen after each test to determine the presence of damage to the bond and to the cylinder wall. After each run, at least two check tests were performed to determine the repeatability of experimental collapse loads. In all cases the reported collapse loads could be duplicated. The repeatability of results was taken to be an indication that the large deformations experienced by the cylinder had no deleterious effects on the test cylinders that would influence the next test.

In an effort to reduce the variation of material properties with temperature and humidity, all tests were performed in a controlled environment; room temperature was regulated between 70° F and 74° F (294° K and 296° K), and the relative humidity remained less than 50 percent.

It was not the intent of the test program to conduct a detailed investigation into the material properties of the plastic film. No measurements were made to accurately establish Poisson's ratio μ , and thickness measurements were performed only to verify the nominal thickness of the material. These nominal thicknesses were used in reducing the data. The results of modulus tests are given in table II. Two types of tensile tests on strips of plastic film 1.0 inch (2.54 cm) wide and one test on a cylinder were performed. On the basis of these tests and on the basis of the results of reference 4, Young's modulus E was taken as 700 000 psi (4.82 GN/m²) and Poisson's ratio μ was taken as 1/3. It should be noted that the combined-load data presented herein are rather insensitive to the exact values of E and μ employed in reducing the data. The quantity Et^2 appears in the expression for P'_0 and for p^* but otherwise these values are not used. The term with Et^2 in the expression for P'_0 is small compared with the other term for cylinders with large radius-thickness ratios and internal pressures. The effect on the value of p^* is more direct but small changes of p^* in the region considered do not seriously affect the results.

RESULTS AND DISCUSSION

The combinations of compressive load P and bending moment M for collapse of the cylinders are given in table I. Each group of data in the table shows results obtained from one cylinder; the initial row of each group shows the collapse load for pure compression, subsequent rows show combinations of compression and bending, and the last row of each group, the collapse moment for pure bending. The pure loading tests were performed principally to obtain

reference points for the combined-load data; however, some comments regarding the pure loading results follow.

Pure Compression

The experimental collapse loads for pure compression P_O were divided by the theoretical collapse load P'_O where

$$P'_O = p\pi r^2 + 2\pi r t \left[\frac{Et}{r\sqrt{3(1-\mu^2)}} \right]$$

The results are shown in the column P_O/P'_O in table I. The values of P_O/P'_O are seen to be slightly above unity in most cases as might be expected for the following reasons:

(a) The spliced material is not included in the theoretical calculations

(b) The thickness of the material probably deviates from the nominal value used in the calculations. This deviation might be expected to be most noticeable for the thinnest gage material and this reasoning is consistent with the test results

(c) The modulus of elasticity may differ from the value assumed and discussed under Test Specimens and Procedures

Although these shortcomings are worthy of mention, the validity of the test results for the pure-compressive loads is demonstrated by the reasonably good agreement with the theoretical values and the substantiation of the loads provided by the duplicate tests.

Pure Bending

The experimental collapse moments for pure bending M_O were divided by the theoretical membrane-collapse moments M'_O where

$$M'_O = p\pi r^3$$

It should be noted that the reference moment M'_O does not include the effect of wall stiffness of the cylinder as was the case for the reference load P'_O shown in the previous section. In the case of the moment loading, uncertainty exists as to the contribution of the wall stiffness. (See refs. 1 and 2.) Consequently the membrane moment without any wall stiffness contribution was used as the reference moment herein. The results are shown in the column headed M_O/M'_O in table I. Whereas theoretical considerations indicate that the value of M_O/M'_O should be greater than unity, the results are seen to be slightly below unity in most cases; the following causes may contribute to these low results:

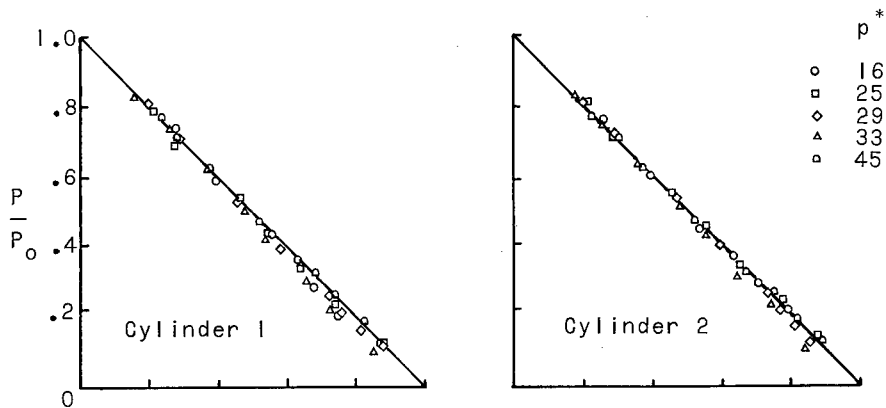

(a) $r/t = 3000$.

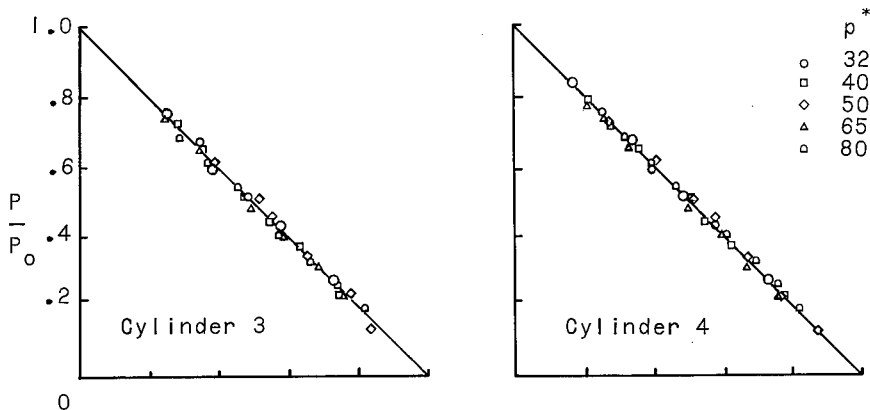

(b) $r/t = 6000$.

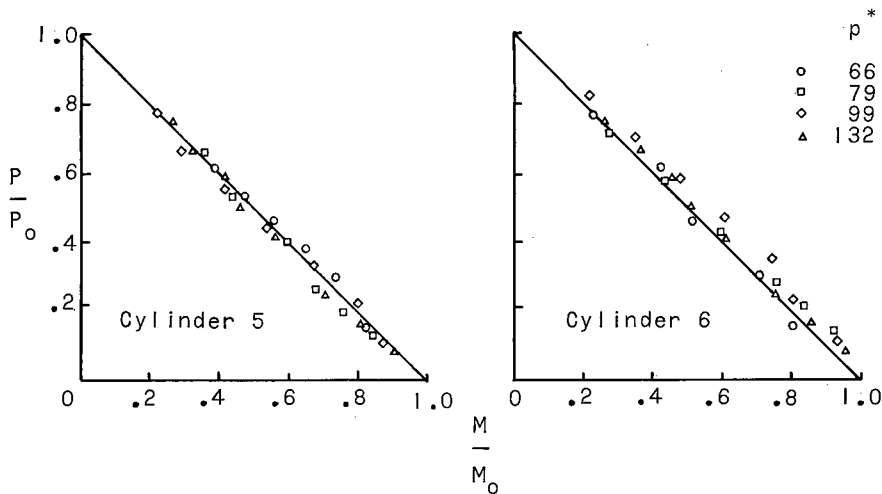

(c) $r/t = 12000$.

Figure 4. - Combined compression and bending of pressurized cylinders.

(a) The collapse of the cylinders at the lowest pressure (initial test in each case) may have minutely creased or weakened the material so that a preferred buckling mode occurred when the cylinders were subsequently tested at higher pressures

(b) Although deep wrinkling encompassed much of the periphery of the cylinder when each test was completed (see Test Specimens and Procedures), the complete periphery was not buckled as assumed by the limit theory result for M_0 .

Combined Compression and Bending

The experimental combined load and moment for collapse were divided by the experimental pure load and moment, respectively, for each cylinder and the results are given under the columns P/P_0 and M/M_0 in table I. These results are presented in figure 4, and are compared with a linear interaction curve given by

$$\frac{P}{P_0} + \frac{M}{M_0} = 1$$

The linear relationship is in good agreement with experimental data for all the cylinders tested and is presumed to be representative of cylinders with a length-radius ratio less than those tested ($l/r = 3.0$). The linear behavior would not be expected for cylinders much longer than those tested; column-bending effects for longer cylinders would be expected to produce deviations from the linear behavior found for the test cylinders. (See ref. 5.)

CONCLUDING REMARKS

Combined-load tests of internally pressurized cylinders with a length-radius ratio of three and with large values of the radius-thickness ratio show a linear relationship of compressive loads and bending moments for collapse of the cylinders. Column-bending effects for longer cylinders would be expected to produce deviations from the linear behavior found for the test cylinders.

Langley Research Center,
National Aeronautics and Space Administration,
Langley Station, Hampton, Va., March 3, 1965.

REFERENCES

1. Zender, George W.: The Bending Strength of Pressurized Cylinders. J. Aerospace Sci. (Readers' Forum), vol. 29, no. 3, Mar. 1962, pp. 362-363.
2. McComb, Harvey G., Jr.; Zender, George W.; and Mikulas, Martin M., Jr.: The Membrane Approach to Bending Instability of Pressurized Cylindrical Shells. Collected Papers on Instability of Shell Structures - 1962, NASA TN D-1510, 1962, pp. 229-238.
3. Mechtly, E. A.: The International System of Units, Physical Constants and Conversion Factors. NASA SP-7012, 1964.
4. Seide, P.; Weingarten, V. I.; and Morgan, E. J.: The Development of Design Criteria for Elastic Stability of Thin Shell Structures. STL/TR-60-000-19425 (AFBMD/TR-61-7) Space Technol. Lab., Inc., Dec. 31, 1960.
5. Jahsman, W. E.: Combined Bending and Compression of a Pressurized Circular Cylindrical Membrane Column. Paper No. 64 - WA/Av-2, Am. Soc. Mech. Engrs., 1964.

TABLE I.- DIMENSIONS AND TEST RESULTS

(a) Cylinder 1: $t = 0.001$ in. ($25.4 \mu\text{m}$); $r/t = 3000$

P		M		$\frac{P}{P_0}$	$\frac{M}{M_0}$	$\frac{P_0}{P_0}$	$\frac{M_0}{M_0}$	
lb	N	in-lb	mN					
$p^* = 16; p = 0.368$ psi (2537 N/m ²)								
13.0	57.9	0	0	1.00	0	1.00		
9.7	43.2	9.00	1.02	.75	.28			
7.7	34.3	12.75	1.44	.59	.40			
5.7	25.4	18.00	2.03	.44	.56			
4.7	20.9	20.25	2.29	.36	.63			
3.7	16.5	21.75	2.46	.28	.68			
2.7	12.0	24.00	2.71	.21	.74			
0	0	32.22	3.63	0	1.00			
$p^* = 25; p = 0.580$ psi (3999 N/m ²)								
19.7	87.7	0	0	1.00	0	1.03		
15.7	69.9	9.75	1.10	.80	.21			
13.7	61.0	12.75	1.44	.70	.27			
10.7	47.6	21.75	2.45	.54	.46			
8.7	38.7	25.50	2.88	.44	.54			
6.7	29.8	30.00	3.39	.34	.64			
4.7	20.9	34.50	3.90	.24	.73			
2.7	12.0	41.25	4.65	.14	.87			
0	0	47.22	5.34	0	1.00			
$p^* = 29; p = 0.677$ psi (4668 N/m ²)								
22.0	97.7	0	0	1.00	0	1.01		
17.7	78.8	11.25	1.27	.81	.21			
15.7	69.9	15.75	1.78	.72	.29			
11.7	52.1	24.75	2.80	.53	.45			
8.7	38.7	31.50	3.56	.40	.58			
5.7	25.4	39.00	4.41	.26	.71			
4.7	20.9	41.25	4.66	.21	.75			
3.7	16.5	44.25	5.00	.17	.81			
2.7	12.0	48.00	5.42	.12	.88			
0	0	54.72	6.18	0	1.00			
$p^* = 33; p = 0.770$ psi (5309 N/m ²)								
25.2	112.1	0	0	1.00	0	1.03		
20.7	92.1	10.50	1.19	.82	.17			
18.7	83.2	15.75	1.78	.74	.25			
15.7	69.9	22.50	2.54	.62	.36			
12.7	56.5	29.25	3.31	.50	.47			
10.7	47.6	33.00	3.73	.42	.53			
7.7	34.3	40.50	4.58	.31	.65			
5.7	25.4	45.00	5.09	.23	.72			
2.7	12.0	52.50	5.93	.11	.85			
0	0	62.10	7.02	0	1.00			
$p = 45; p = 1.063$ psi (7329 N/m ²)								
33.2	147.7	0	0	1.00	0	1.01		
25.7	114.4	18.00	2.03	.77	.23			
23.7	105.5	22.50	2.54	.71	.29			
20.7	92.1	29.25	3.31	.62	.37			
15.7	69.9	40.50	4.58	.47	.52			
10.7	47.6	52.50	5.93	.32	.67			
8.7	38.7	57.75	6.53	.26	.73			
5.7	25.4	64.50	7.29	.17	.82			
3.7	16.5	69.00	7.80	.11	.88			
0	0	78.60	8.80	0	1.00			
0.87								

TABLE I.-- DIMENSIONS AND TEST RESULTS - Continued

(b) Cylinder 2: $t = 0.001$ in. ($25.4 \mu\text{m}$); $r/t = 3000$

P		M		$\frac{P}{P_0}$	$\frac{M}{M_0}$	$\frac{P_0}{P_0}$	$\frac{M_0}{M_0}$
lb	N	in-lb	mN				
$p^* = 16; p = 0.368$ psi (2537 N/m ²)							
12.7	56.5	0	0	1.00	0	0.97	
9.7	43.2	8.25	.93	.76	.26		
7.7	34.3	12.75	1.44	.61	.40		
5.7	25.4	17.25	1.95	.45	.54		
4.7	20.9	20.25	2.29	.37	.63		
3.7	16.5	22.50	2.54	.29	.70		
2.7	12.0	25.50	2.88	.21	.79		
0	0	32.10	3.63	0	1.00		1.03
$p^* = 25; p = 0.580$ psi (3999 N/m ²)							
19.2	85.4	0	0	1.00	0	1.01	
15.7	69.9	9.75	1.10	.82	.21		
13.7	61.0	13.50	1.53	.71	.29		
10.7	47.6	21.00	2.37	.56	.45		
8.7	38.7	25.50	2.88	.45	.55		
6.7	29.8	30.00	3.39	.35	.65		
4.7	20.9	36.00	4.07	.24	.78		
2.7	12.0	40.50	4.58	.14	.87		
0	0	46.35	5.24	0	1.00		0.94
$p^* = 29; p = 0.677$ psi (4668 N/m ²)							
21.7	96.6	0	0	1.00	0	1.00	
17.7	78.8	11.25	1.27	.81	.21		
15.7	69.9	15.75	1.78	.72	.29		
11.7	52.1	25.50	2.88	.54	.47		
8.7	38.7	32.25	3.64	.40	.59		
5.7	25.4	39.75	4.49	.26	.73		
4.7	20.9	42.00	4.75	.22	.77		
3.7	16.5	44.25	5.00	.17	.81		
2.7	12.0	46.50	5.25	.12	.85		
0	0	54.60	6.17	0	1.00		0.95
$p^* = 33; p = 0.770$ psi (5309 N/m ²)							
24.7	109.9	0	0	1.00	0	1.01	
20.7	92.1	11.25	1.27	.84	.18		
18.7	83.2	15.75	1.78	.76	.25		
15.7	69.9	22.50	2.54	.64	.36		
12.7	56.5	30.00	3.39	.51	.48		
10.7	47.6	34.50	3.90	.43	.55		
7.7	34.3	40.50	4.58	.31	.64		
5.7	25.4	46.50	5.25	.23	.74		
2.7	12.0	53.25	6.02	.11	.85		
0	0	62.85	7.10	0	1.00		0.96
$p^* = 45; p = 1.063$ psi (7329 N/m ²)							
33.2	147.7	0	0	1.00	0	1.01	
25.7	114.4	18.00	2.03	.77	.22		
23.7	105.5	24.00	2.71	.71	.30		
20.7	92.1	30.00	3.39	.62	.37		
15.7	69.9	42.00	4.75	.47	.52		
10.7	47.6	54.00	6.10	.32	.67		
8.7	38.7	60.00	6.78	.26	.74		
5.7	25.4	66.00	7.46	.17	.81		
3.7	16.5	72.00	8.14	.11	.89		
0	0	81.00	9.15	0	1.00		0.90

TABLE I.- DIMENSIONS AND TEST RESULTS - Continued

(c) Cylinder 3: $t = 0.0005$ in. (12.7 μm); $r/t = 6000$

P		M		$\frac{P}{P_0}$	$\frac{M}{M_0}$	$\frac{P_0}{P_0^T}$	$\frac{M_0}{M_0^T}$		
lb	N	in-lb	mN						
$p^* = 32$; $p = 0.191$ psi (1317 N/m ²)									
6.2	27.6	0	0	1.00	0	1.14	0.95		
4.7	20.9	4.00	.45	.76	.25				
4.2	18.7	5.49	.62	.68	.34				
3.7	16.5	6.24	.71	.60	.39				
3.2	14.2	7.74	.87	.52	.48				
2.7	12.0	9.24	1.04	.44	.58				
1.7	7.6	11.64	1.32	.27	.73				
0	0	16.00	1.81	0	1.00				
$p^* = 40$; $p = 0.236$ psi (1627 N/m ²)									
7.2	32.0	0	0	1.00	0			0.98	0.98
5.2	23.1	5.49	.62	.72	.28				
4.7	20.9	7.00	.79	.65	.36				
3.7	16.5	9.30	1.05	.51	.48				
3.2	14.2	10.74	1.21	.44	.55				
2.7	12.0	12.24	1.38	.38	.63				
1.7	7.6	14.49	1.64	.24	.74				
0	0	19.50	2.20	0	1.00				
$p^* = 50$; $p = 0.295$ psi (2034 N/m ²)									
9.2	40.9	0	0	1.00	0	1.02	0.92		
5.7	25.4	9.00	1.02	.62	.39				
4.7	20.9	12.00	1.36	.51	.52				
4.2	18.7	12.75	1.44	.46	.55				
3.2	14.2	15.00	1.70	.35	.65				
2.2	9.8	18.00	2.03	.24	.78				
1.2	5.3	19.25	2.18	.13	.83				
0	0	23.10	2.61	0	1.00				
$p^* = 65$; $p = 0.383$ psi (2641 N/m ²)									
11.7	52.1	0	0	1.00	0			1.02	0.94
8.7	38.7	7.50	.85	.74	.25				
7.7	34.3	10.50	1.19	.66	.34				
5.7	25.4	15.00	1.70	.49	.49				
4.7	20.9	18.00	2.03	.40	.59				
3.7	16.5	21.00	2.37	.32	.69				
2.7	12.0	23.25	2.63	.23	.76				
0	0	30.60	3.46	0	1.00				
$p^* = 80$; $p = 0.472$ psi (3254 N/m ²)									
13.5	60.1	0	0	1.00	0	0.96	0.92		
9.7	43.2	10.50	1.19	.72	.29				
8.7	38.7	13.50	1.53	.64	.37				
7.7	34.3	16.50	1.86	.57	.45				
5.7	25.4	21.00	2.37	.42	.57				
4.7	20.9	24.00	2.71	.35	.66				
3.7	16.5	27.00	3.05	.27	.74				
2.7	12.0	30.00	3.39	.20	.82				
0	0	36.60	4.14	0	1.00				

TABLE I.- DIMENSIONS AND TEST RESULTS - Continued

(d) Cylinder 4: $t = 0.0005$ in. ($12.7 \mu\text{m}$); $r/t = 6000$

P		M		$\frac{P}{P_0}$	$\frac{M}{M_0}$	$\frac{P_0}{P_0^i}$	$\frac{M_0}{M_0^i}$
lb	N	in-lb	mN				
$p^* = 32$; $p = 0.191$ psi (1317 N/m ²)							
6.2	27.6	0	0	1.00	0	1.14	
5.2	23.1	2.64	.30	.84	.17		
4.7	20.9	4.00	.45	.76	.25		
4.2	18.7	5.49	.62	.68	.34		
3.7	16.5	6.24	.71	.60	.39		
3.2	14.2	7.74	.87	.52	.48		
2.7	12.0	9.24	1.04	.44	.58		
1.7	7.6	11.64	1.32	.27	.73		
0	0	16.00	1.81	0	1.00		0.95
$p^* = 40$; $p = 0.236$ psi (1627 N/m ²)							
7.2	32.0	0	0	1.00	0	0.98	
5.7	25.4	4.00	.45	.79	.20		
5.2	23.1	5.49	.62	.72	.28		
4.7	20.9	7.00	.79	.65	.35		
3.7	16.5	10.00	1.13	.51	.51		
3.2	14.2	10.74	1.21	.44	.54		
2.7	12.0	12.24	1.38	.38	.62		
1.7	7.6	15.24	1.72	.24	.77		
0	0	19.74	2.23	0	1.00		0.99
$p^* = 50$; $p = 0.295$ psi (2034 N/m ²)							
9.2	40.9	0	0	1.00	0	1.02	
6.7	29.8	6.24	.71	.73	.27		
5.7	25.4	9.24	1.04	.62	.41		
4.7	20.9	11.49	1.30	.51	.51		
4.2	18.7	13.00	1.47	.46	.57		
3.2	14.2	15.24	1.72	.35	.67		
2.2	9.8	17.49	1.98	.24	.77		
1.2	5.3	19.74	2.23	.13	.87		
0	0	22.74	2.57	0	1.00		0.91
$p^* = 65$; $p = 0.383$ psi (2641 N/m ²)							
11.7	52.1	0	0	1.00	0	1.02	
9.2	40.9	6.24	.71	.79	.20		
8.7	38.7	7.74	.87	.74	.25		
7.7	34.3	10.00	1.13	.66	.32		
5.7	25.4	15.24	1.72	.49	.49		
4.7	20.9	18.24	2.06	.40	.59		
3.7	16.5	20.49	2.32	.32	.66		
2.7	12.0	23.49	2.65	.23	.76		
0	0	31.00	3.50	0	1.00		0.96
$p^* = 80$; $p = 0.472$ psi (3254 N/m ²)							
14.2	63.2	0	0	1.00	0	1.01	
9.7	43.2	11.49	1.30	.68	.32		
8.7	38.7	14.49	1.64	.61	.40		
7.7	34.3	16.74	1.89	.54	.46		
5.7	25.4	22.00	2.49	.40	.61		
4.7	20.9	25.00	2.83	.33	.69		
3.7	16.5	27.24	3.08	.26	.75		
2.7	12.0	29.49	3.33	.19	.81		
0	0	36.24	4.10	0	1.00		0.91

TABLE I.- DIMENSIONS AND TEST RESULTS - Continued

(e) Cylinder 5: $t = 0.00025$ in. ($6.4 \mu\text{m}$); $r/t = 12\ 000$

P		M		$\frac{P}{P_0}$	$\frac{M}{M_0}$	$\frac{P_0}{P_0^T}$	$\frac{M_0}{M_0^T}$
lb	N	in-lb	mN				
$p^* = 66; p = 0.10$ psi (689 N/m ²)							
3.25	14.5	0	0	1.00	0	1.08	
2.00	8.9	3.27	.37	.62	.38		
1.75	7.8	4.00	.45	.54	.47		
1.50	6.7	4.77	.54	.46	.56		
1.25	5.6	5.52	.62	.38	.65		
1.00	4.5	6.27	.71	.31	.74		
.50	2.2	7.02	.79	.15	.82		
0	0	8.52	.96	0	1.00		1.01
$p^* = 79; p = 0.12$ psi (827 N/m ²)							
3.75	16.7	0	0	1.00	0	1.05	
2.50	11.1	3.27	.37	.67	.35		
2.00	8.9	4.00	.45	.53	.43		
1.50	6.7	5.52	.62	.40	.60		
1.00	4.5	6.27	.71	.27	.68		
.75	3.3	7.02	.79	.20	.76		
.50	2.2	7.77	.88	.13	.84		
0	0	9.27	1.05	0	1.00		0.92
$p^* = 99; p = 0.15$ psi (1034 N/m ²)							
4.50	20.0	0	0	1.00	0	1.02	
3.50	15.6	2.52	.28	.78	.22		
3.00	13.4	3.27	.37	.67	.28		
2.50	11.1	4.77	.54	.56	.41		
2.00	8.9	6.27	.71	.44	.54		
1.50	6.7	7.77	.88	.33	.67		
1.00	4.5	9.27	1.05	.22	.80		
.50	2.2	10.00	1.13	.11	.87		
0	0	11.52	1.30	0	1.00		0.91
$p^* = 132; p = 0.20$ psi (1379 N/m ²)							
6.00	26.7	0	0	1.00	0	1.03	
4.50	20.0	4.00	.45	.75	.26		
4.00	17.8	4.77	.54	.67	.31		
3.50	15.6	6.27	.71	.58	.41		
3.00	13.4	7.02	.79	.50	.46		
2.50	11.1	8.52	.96	.42	.56		
1.50	6.7	10.77	1.22	.25	.71		
1.00	4.5	12.27	1.39	.17	.80		
.50	2.2	13.77	1.56	.08	.90		
0	0	15.27	1.73	0	1.00		0.90

TABLE I.- DIMENSIONS AND TEST RESULTS - Concluded

(f) Cylinder 6: $t = 0.00025$ in. ($6.4 \mu\text{m}$); $r/t = 12\ 000$

P		M		$\frac{P}{P_0}$	$\frac{M}{M_0}$	$\frac{P_0}{P_0}$	$\frac{M_0}{M_0}$
lb	N	in-lb	mN				
$p^* = 66; p = 0.10$ psi (689 N/m ²)							
3.25	14.5	0	0	1.00	0	1.08	
2.50	11.1	1.77	.20	.77	.23		
2.00	8.9	3.27	.37	.62	.42		
1.50	6.7	4.00	.45	.46	.51		
1.00	4.5	5.52	.62	.31	.71		
.50	2.2	6.27	.71	.15	.81		
0	0	7.77	.88	0	1.00		
$p^* = 79; p = 0.12$ psi (827 N/m ²)							
3.50	15.6	0	0	1.00	0	0.98	
2.50	11.1	2.52	.28	.71	.27		
2.00	8.9	4.00	.45	.57	.43		
1.50	6.7	5.52	.62	.43	.60		
1.00	4.5	7.02	.79	.29	.76		
.75	3.3	7.77	.88	.21	.84		
.50	2.2	8.52	.96	.14	.92		
0	0	9.27	1.05	0	1.00		
$p^* = 99; p = 0.15$ psi (1034 N/m ²)							
4.25	18.9	0	0	1.00	0	0.97	
3.50	15.6	2.25	.25	.82	.20		
3.00	13.4	4.00	.45	.71	.35		
2.50	11.1	5.52	.62	.59	.48		
2.00	8.9	7.02	.79	.47	.61		
1.50	6.7	8.52	.96	.35	.74		
1.00	4.5	9.27	1.05	.24	.80		
.50	2.2	10.77	1.22	.12	.93		
0	0	11.52	1.30	0	1.00		
$p^* = 132; p = 0.20$ psi (1379 N/m ²)							
6.00	26.7	0	0	1.00	0	1.03	
4.50	20.0	4.00	.45	.75	.26		
4.00	17.8	5.52	.62	.67	.36		
3.50	15.6	7.02	.79	.58	.46		
3.00	13.4	7.77	.88	.50	.51		
2.50	11.1	9.27	1.05	.42	.61		
1.50	6.7	11.52	1.30	.25	.75		
1.00	4.5	13.02	1.47	.17	.85		
.50	2.2	14.52	1.64	.08	.95		
0	0	15.27	1.72	0	1.00		

TABLE II.-- TEST RESULTS ON PLASTIC FILM TO DETERMINE YOUNG'S MODULUS E

Direction of roll	Values of Young's modulus E obtained for -					
	Controlled strain rate (0.005/min)		Controlled stress		Load-shortening observations on 1.0 mil (25.4 μ m) cylinder	
	ksi	GN/m ²	ksi	GN/m ²	ksi	GN/m ²
Transverse	584.5	4.02	603	4.16	---	---
Transverse	589.3	4.06	757	5.22	---	---
Transverse	597.3	4.12	678	4.67	---	---
Longitudinal	705.2	4.86	847	5.84	605	4.17
Longitudinal	630.3	4.37	706	4.87	569	3.92

"The aeronautical and space activities of the United States shall be conducted so as to contribute . . . to the expansion of human knowledge of phenomena in the atmosphere and space. The Administration shall provide for the widest practicable and appropriate dissemination of information concerning its activities and the results thereof."

—NATIONAL AERONAUTICS AND SPACE ACT OF 1958

NASA SCIENTIFIC AND TECHNICAL PUBLICATIONS

TECHNICAL REPORTS: Scientific and technical information considered important, complete, and a lasting contribution to existing knowledge.

TECHNICAL NOTES: Information less broad in scope but nevertheless of importance as a contribution to existing knowledge.

TECHNICAL MEMORANDUMS: Information receiving limited distribution because of preliminary data, security classification, or other reasons.

CONTRACTOR REPORTS: Technical information generated in connection with a NASA contract or grant and released under NASA auspices.

TECHNICAL TRANSLATIONS: Information published in a foreign language considered to merit NASA distribution in English.

TECHNICAL REPRINTS: Information derived from NASA activities and initially published in the form of journal articles.

SPECIAL PUBLICATIONS: Information derived from or of value to NASA activities but not necessarily reporting the results of individual NASA-programmed scientific efforts. Publications include conference proceedings, monographs, data compilations, handbooks, sourcebooks, and special bibliographies.

Details on the availability of these publications may be obtained from:

SCIENTIFIC AND TECHNICAL INFORMATION DIVISION
NATIONAL AERONAUTICS AND SPACE ADMINISTRATION
Washington, D.C. 20546