

Bo 56033

**NASA CONTRACTOR  
REPORT**

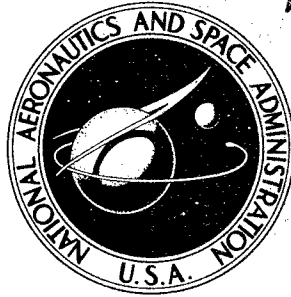

**NASA CR-79**

NASA CR-79

**AMPTIAC**

56033

**DISTRIBUTION STATEMENT A**  
Approved for Public Release  
Distribution Unlimited

**THE DEVELOPMENT OF  
MAGNESIUM-LITHIUM ALLOYS  
FOR STRUCTURAL APPLICATIONS**

*by T. G. Byrer, E. L. White, and P. D. Frost*

Prepared under Contract No. NAS 8-5049 by  
**BATTELLE MEMORIAL INSTITUTE**  
Columbus, Ohio

*for*

20011217 160

56033

THE DEVELOPMENT OF MAGNESIUM-LITHIUM ALLOYS  
FOR STRUCTURAL APPLICATIONS

By T. G. Byrer, E. L. White, and P. D. Frost

Prepared under Contract No. NAS 8-5049 by  
BATTELLE MEMORIAL INSTITUTE  
Columbus, Ohio

**Reproduced From  
Best Available Copy**

This report was reproduced photographically from copy supplied by the contractor. Its publication should not be construed as an endorsement or evaluation by NASA of any commercial product.

NATIONAL AERONAUTICS AND SPACE ADMINISTRATION

---

For sale by the Office of Technical Services, Department of Commerce,  
Washington, D. C. 20230 -- Price \$2.50

TABLE OF CONTENTS

	<u>Page</u>
INTRODUCTION . . . . .	1
SUMMARY . . . . .	1
SHEET FORMABILITY . . . . .	2
Sheet Fabrication . . . . .	3
Forming Studies . . . . .	5
TUBE-EXTRUSION STUDIES . . . . .	12
Extrusion Procedure . . . . .	12
Extrusion Results . . . . .	18
METAL-REMOVAL STUDIES . . . . .	21
Machinability . . . . .	21
Chemical Milling . . . . .	25
ELECTROPLATED COATINGS . . . . .	31
Chemical Prefinishing and Activating . . . . .	31
Zincate Activation . . . . .	32
Copper Plating . . . . .	32
Nickel Plating . . . . .	33
Aluminum Plating . . . . .	33
BRAZING STUDIES . . . . .	33

APPENDIX A

CORROSION RESISTANCE AND CORROSION PROTECTION OF MAGNESIUM-LITHIUM ALLOYS - A REVIEW OF THE PRESENT STATE OF DEVELOPMENT . . . . .	A-1
--	-----

APPENDIX B

DATA SHEETS ON SURFACE TREATMENTS AND COATINGS FOR COMMERCIAL MAGNESIUM ALLOYS . . . . .	B-1
---	-----

# THE DEVELOPMENT OF MAGNESIUM-LITHIUM ALLOYS FOR STRUCTURAL APPLICATIONS

by

T. G. Byrer, E. L. White, and P. D. Frost

## INTRODUCTION

The research described in this report continued the investigation of magnesium-lithium alloys conducted during 1957-1959 for the George C. Marshall Space Flight Center. The final report\* of the earlier research received wide distribution and stimulated the present interest in the use of magnesium-lithium alloys for missile and space hardware components. The present contract was initiated in June, 1962, and terminated in January, 1963.

## SUMMARY

Exploratory studies were initiated on magnesium-lithium alloys LA141 and LA91 in the following areas:

Formability of sheet  
Extrusion of thin-wall tubing  
Machinability  
Chemical milling  
Deposition of metallic coatings  
Brazing  
Corrosion behavior and protection.

The capability of LA141 to be warm formed into typical aerospace parts requiring simultaneous shrink and stretch operations was demonstrated. Likewise, the ability of the alloy to be extruded through porthole dies into tubular sections having a wall 0.025 inch thick was shown.

The LA141 alloy was found to have machinability, in lathe tests, comparable to that of 2024 aluminum alloy at low feed rates but much greater than the aluminum alloy at high feed rates. Both LA141 and LA91 were found to be readily adaptable to metal removal by chemical milling. Phosphoric acid solutions appear to be suitable reagents in this respect.

\*"Evaluation of Magnesium-Lithium Alloys for Possible Missile and Space Applications", Battelle Memorial Institute, January 31, 1960, Army Ballistic Missile Agency Contract DA-33-019-ORD-2593.

Limited experiments were conducted on electroplating of copper, nickel, and aluminum on LA141 alloy. Electroplating was found to be feasible for this alloy. Further research will be needed to scale up these experiments for larger surfaces.

Brazing experiments revealed that existing brazing filler metals for commercial magnesium alloys are not suitable for magnesium-lithium alloys because of incompatible melting ranges. The development of special brazing filler metals will be required.

A review of the literature on corrosion behavior and protection of magnesium-lithium alloys is given in Appendix A. Data sheets on surface treatments and coatings for commercial magnesium alloys are given in Appendix B. *Lead*

### SHEET FORMABILITY

A total of 175 pounds of 1/4 to 2-inch-thick LA141 alloy plate stock was received from the Dow Metal Products Company, Midland, Michigan, for (1) use in the research program, and (2) for supplying the Sponsor with rolled sheet and extruded tubing for in-house investigations. An additional material order for 50 pounds each of LA141 and LA91 alloys was placed with Magnesium Elektron, Limited, New York, New York. After several delays, a 65-pound ingot of LA91 alloy was received from this supplier but only limited fabrication of this material was possible due to funding limitations on the present contract. The order for the additional LA141 alloy stock was cancelled because Magnesium Elektron had difficulty obtaining the composition specified and their delivery date was delayed. The funds were used for additional effort in laboratory research.

Spectrographic analysis of the Dow material was obtained and the results are listed below along with two commercial material specifications which are available.

	<u>Dow</u> <u>Material</u>	<u>Lockheed</u> <u>Specification</u>	<u>IBM</u> <u>Specification</u>
Li	13.6	13-15	13.5-14.5
Al	0.82	0.75-1.25	1-2
Mn	0.10	0.05 max	0.15 max
Fe	0.001	0.005 max	0.005 max
Cu	0.003	n. a. (a)	0.04 max
Ni	<0.001	n. a. (a)	0.005 max
Na	0.02	0.003 max	0.005 max
Si	0.003	n. a. (a)	0.10 max

(a) Not available.

The only impurity content which does not fall within one or the other of the two specifications is sodium. In alloys of this strength level 0.02 per cent sodium is not believed to be critical to ductility, and although the sodium is well above specifications placed by other organizations\*, this is not a matter for concern.

\*The Lockheed and IBM specifications for sodium are believed to be based on prior research done at Battelle and Dow.

Analysis of the Magnesium Elektron LA91 alloy material was provided by the supplier and is given below:

Element	Analysis, per cent	
	Ingot 780	Ingot 781
Li	9.6	9.6
Al	1.5	1.55
Mn	0.08	0.10
Fe	0.007	0.006
Cu	0.002	0.002
Ni	0.001	0.001
Na	0.0036	0.0038
Si	0.005	0.005

Impurity contents agree favorably with the material specification listed previously, except for the iron contents which are slightly higher than the 0.005 per cent maximum required by the Lockheed and IBM specifications.

#### Sheet Fabrication

Sheet material was fabricated for (1) research studies on chemical milling, electroplating, and brazing, and (2) supplying the Sponsor with 0.050- and 0.100-inch-thick sheet. Rolling was done on Battelle's 16 by 24-inch two-high mill at roll speeds of 100 ft/min for reductions down to 0.250 inch thick, and 60 ft/min from 0.250 inch to finish size. A water-soluble oil mixture was sprayed on the rolls for lubrication during rolling.

Four pieces of LA141 ingot material which remained from the previous research program on Contract DA-33-019-ORD-2593 also was processed to 0.100, 0.065, and 0.050-inch-thick sheet for use in the research studies mentioned earlier. This amounted to 9.3 pounds of sheet. Three pieces of Dow material were processed to 0.050-inch-thick sheet for shipment to the Sponsor according to the processing schedule presented in Table 1. This material totaled 40.7 pounds in initial plate weight. A total of 37 pounds was ultimately shipped to the Sponsor. Two rolled sheets showed evidence of laps apparently from defects in the original material. This material was scrapped.

One piece of Dow material measuring 1 by 3-1/8 by 23 inches (4.7 pounds) was similarly processed to 0.100-inch-thick sheet for research studies.

Late in the program, a final shipment of sheet material was made to the Sponsor consisting of:

<u>LA141</u>	<u>LA91</u>
3-1/2 lb 0.050-in.-thick sheet	16-1/2 lb 0.050-in.-thick sheet
8 lb 0.085-in.-thick sheet	16-1/2 lb 0.100-in.-thick sheet
63 lb 0.100-in.-thick sheet	

TABLE 1. PROCESSING SCHEDULE FOR FABRICATION OF 0.050-INCH-THICK  
LA141 ALLOY SHEET

(1)	(2)	(3)
<p>Starting Size: 0.250 x 20 x 36 in.</p> <p>↓</p> <p>Sectioned into six pieces at 0.250 x 18 x 20 in.</p> <p>↓</p> <p>Heated to 500 F and held 1 hour at temperature</p> <p>↓</p> <p>Rolled unidirectionally in 30 per cent passes to 0.121-in. sheet</p> <p>↓</p> <p>Reheated to 500 F</p> <p>↓</p> <p>Rolled unidirectionally in 30 per cent passes to 0.060-in. sheet</p> <p>↓</p> <p>Reheated to 500 F</p> <p>↓</p> <p>Cross rolled in six passes to 0.050-in. sheet</p>	<p>Starting Size: 0.250 x 21-3/4 x 36 in.</p> <p>↓</p> <p>Sectioned into two pieces 0.250 x 18 x 21-3/4 in.</p> <p>↓</p> <p>Processed the same as (1)</p>	<p>Starting Size: 0.437 x 12-1/2 x 14-3/8 in.</p> <p>↓</p> <p>Heated to 500 F and held 30 min at temperature</p> <p>↓</p> <p>Rolled unidirectionally in 30 per cent passes to 0.220-in. plate</p> <p>↓</p> <p>Reheated to 500 F</p> <p>↓</p> <p>Rolled unidirectionally in 30 per cent passes to 0.060-in. sheet</p> <p>↓</p> <p>Sectioned and reheated to 500 F</p> <p>↓</p> <p>Rolled unidirectionally to 0.056-in. sheet</p> <p>↓</p> <p>Rolled <u>cold</u> to 0.050-in. sheet</p> <p>↓</p> <p>Reheated to 250 F for 12 hr<sup>(a)</sup></p>

(a) The cold finishing passes caused sheet warpage and the reheating to 250 F for 12 hours was done under weights to flatten the sheets.

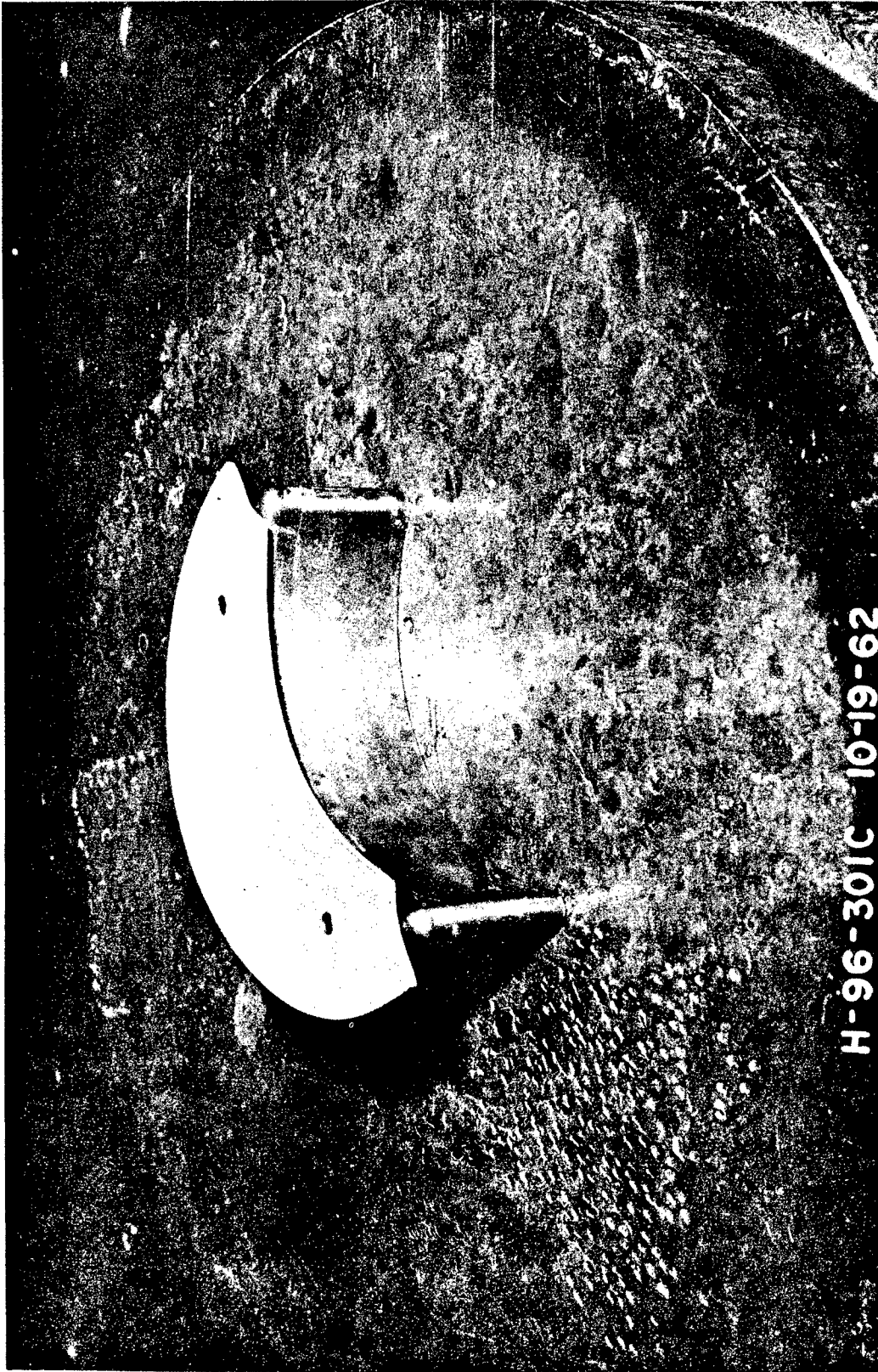

N96445

FIGURE 2. LA141 BLANK POSITIONED ON THE FORMING DIE FOR THE STRETCH-SHRINK FORMABILITY TESTS

Variations in blank size produced varying amounts of stretch and shrink in forming.  
(Photograph courtesy of North American Aviation.)

TABLE 2. RESULTS OF STRETCH-SHRINK<sup>(a)</sup> FORMABILITY TESTS ON LA141 ALLOY SHEET

Specimen	Bend Radius, in.	Blank		Stretch, per cent	Shrink Radius R <sub>3</sub> , in.	Shrink, per cent	Time at 350 F, min	Results
		Stretch Radius R <sub>1</sub> , in.	Shrink Radius					
<u>0.100-Inch-Thick Sheet</u>								
1	3/32	2-5/8	3-3/8	14	3-3/8	11	3	Part completely formed
2	3/32	2-5/8	3-3/8	14	3-3/8	11	2	Ditto
3	3/32	2-5/8	3-3/8	14	3-3/8	11	1	"
4	3/32	2-5/8	3-3/8	14	3-3/8	11	0	Incomplete forming of stretch flange
5	1/8	2-5/8	3-3/8	14	3-3/8	11	0	Ditto
6	1/8	2-1/2	3-1/2	20	3-1/2	14	5	Ripples on shrink flange
7	1/8	2-1/2	3-1/2	20	3-1/2	14	3	Ditto
8	3/32	2-1/2	3-1/2	20	3-1/2	14	3	"
9	3/32	2-1/2	3-1/2	20	3-1/2	14	1	"
10	3/32	2-1/2	3-1/2	20	3-1/2	14	0	Fracture of shrink flange
<u>0.050-Inch-Thick Sheet</u>								
1	1/8	2-3/4	3-1/4	9	3-1/4	7-1/2	0	Part formed completely
2	3/32	2-3/4	3-1/4	9	3-1/4	7-1/2	0	Ditto
3	3/32	2-5/8	3-3/8	14	3-3/8	11	1	"
4	3/32	2-5/8	3-3/8	14	3-3/8	11	0	"
5	1/8	2-5/8	3-3/8	14	3-3/8	11	0	Ripples on shrink flange
6	3/32	2-1/2	3-1/2	20	3-1/2	14	0	Ripples on shrink flange; slight tear on edge of stretch flange
7	3/32	2-1/2	3-1/2	20	3-1/2	14	1	Slight rippling on shrink flange
8	1/8	2-1/2	3-1/2	20	3-1/2	14	1	Ditto
9	1/8	2-1/2	3-1/2	20	3-1/2	14	0	Ripples on shrink flange

(a) Definitions of nomenclature and method for calculating "per cent stretch" and "per cent shrink" are given in Figure 1.

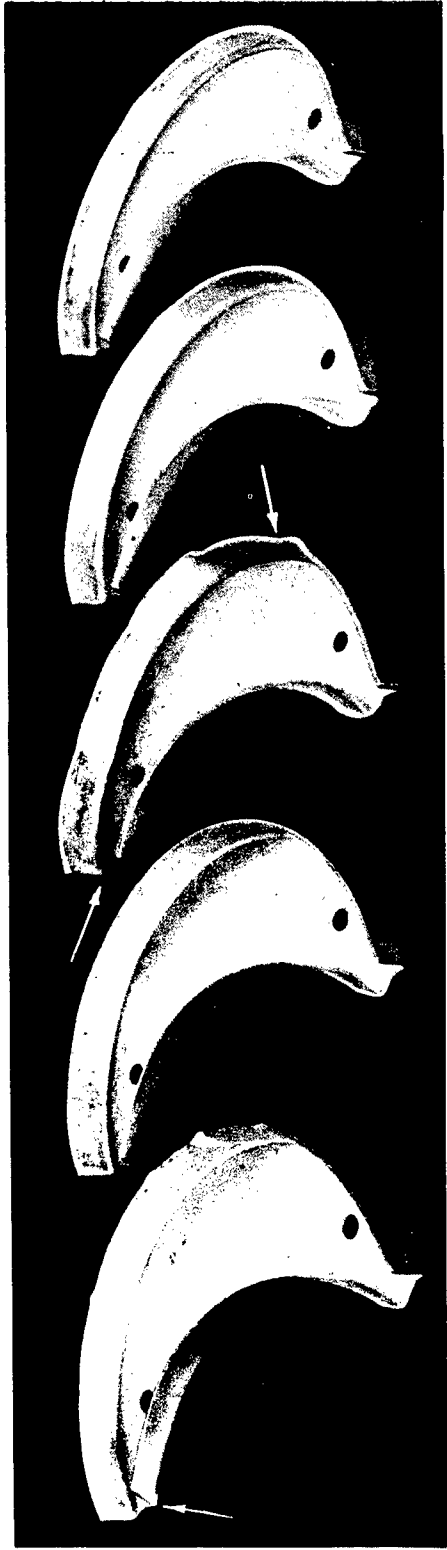

N95065

Gage:	0.050 inch	0.100 inch	0.100 inch	0.100 inch	0.100 inch
Bend Radius:	3/32 inch	3/32 inch	3/32 inch	1/8 inch	3/32 inch
Preheat Time at 350 F:	Cold	1 min	Cold	3 min	1 min

**FIGURE 3. EFFECT OF PREHEAT TIME AT 350 F ON FORMABILITY OF LA141 ALLOY**

Test conditions of 20 per cent stretch-14 per cent shrink. Arrows show location of radius tears.



N95067

b. 0.100 Inch Thick

a. 0.050 Inch Thick

FIGURE 4. SUCCESSFULLY FORMED LA141 PARTS AFTER PREHEATING 1 MINUTE AT 350 F

Test conditions of 20 per cent stretch-14 per cent shrink.

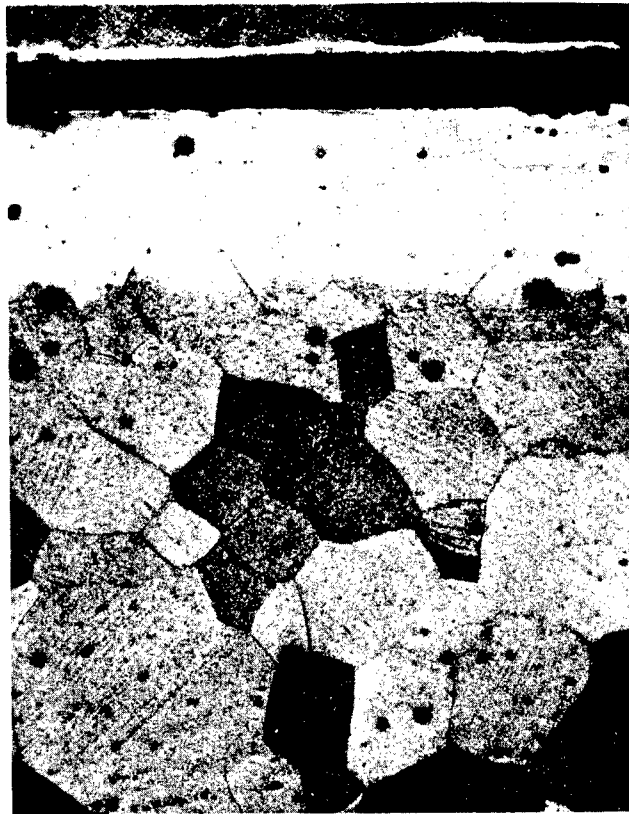

250X

N95954

FIGURE 5. MICROSTRUCTURE OF AN LA141 BLANK USED IN THE STRETCH-SHRINK FORMABILITY STUDIES

Lithium-depleted zone (light area) about 10 mils deep.  
Etched in solution of: 60 parts ethylene glycol, 40 parts  $H_2O$ , 5 parts acetic acid, 1 part  $HNO_3$ .

## TUBE-EXTRUSION STUDIES

The object of this phase of the program was to extrude magnesium-lithium alloys in the form of 1-inch-OD thin-walled (0.025 inch) tubing. An extrusion practice was to be developed and a sample lot of material was to be supplied to the Sponsor.

### Extrusion Procedure

The 2-inch-thick plate stock received from Dow was sectioned into bars 2 by 2 by 36 inches. These bars were press forged at 500 F into 2-1/8-inch-diameter rounds and sectioned into 5 to 6-inch billet lengths. Billets were subsequently machined to 2-inch-diameter rounds for extrusion. During press forging some center splitting of the bars occurred. This material was used but the billets were segregated from the sound stock so that any effects of billet defects could be observed.

Extrusion trials were conducted on the 700-ton hydraulic press in the Battelle Metalworking Laboratory shown in Figure 6. In order to accommodate the use of a 2-inch-diameter billet, auxiliary tooling was designed and built for use with the existing 3.275-inch-diameter container. The tool design used for these studies is shown in Figure 7.

The porthole die assembly was designed and built by Moczik Tool and Die Works, Detroit, Michigan. Design details are shown in Figure 8.

Fifty-two billets of LA141 alloy were extruded under the conditions summarized below:

Extrusion temperature	500-650 F
Container temperature	450-650 F
Die temperature	400-650 F
Ram speed	0.25-1.50 ipm
Tubing runout speed	1-11 fpm
Extrusion ratio	61:1

Extrusion data are presented in Table 3. Billets were heated to temperature in an air-circulating furnace prior to insertion into the container. The die assembly was heated to 650 F at the beginning of each particular series of extrusion trials. The dies were not reheated between pushes, but a die temperature of 450 to 500 F was maintained throughout most of the extrusion trials.

Colloidal graphite was sprayed on the die and in the liner bore prior to the first extrusion trial. No additional lubrication was used in subsequent trials.

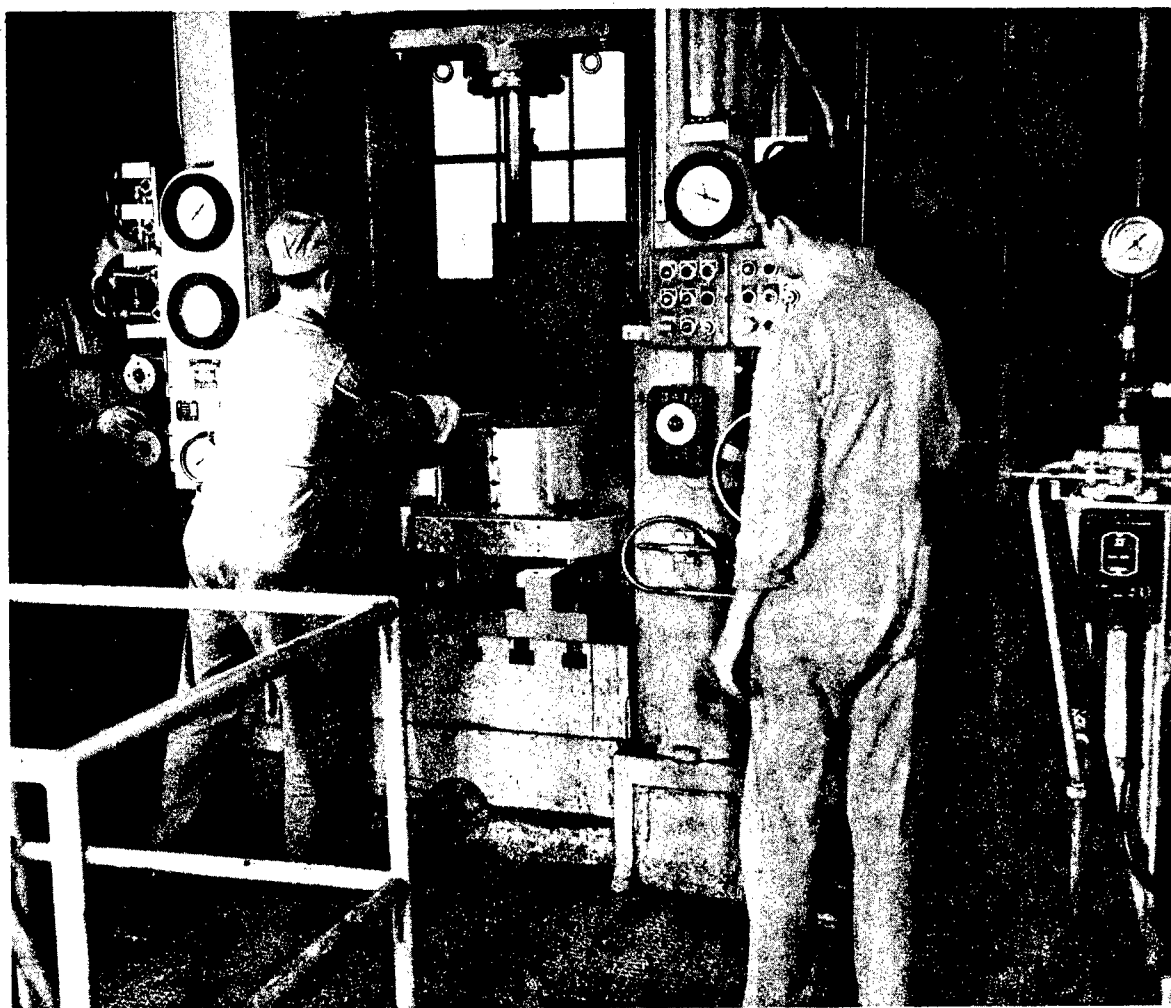

N37233

FIGURE 6. 700-TON EXTRUSION PRESS IN BATTELLE'S METALWORKING LABORATORY

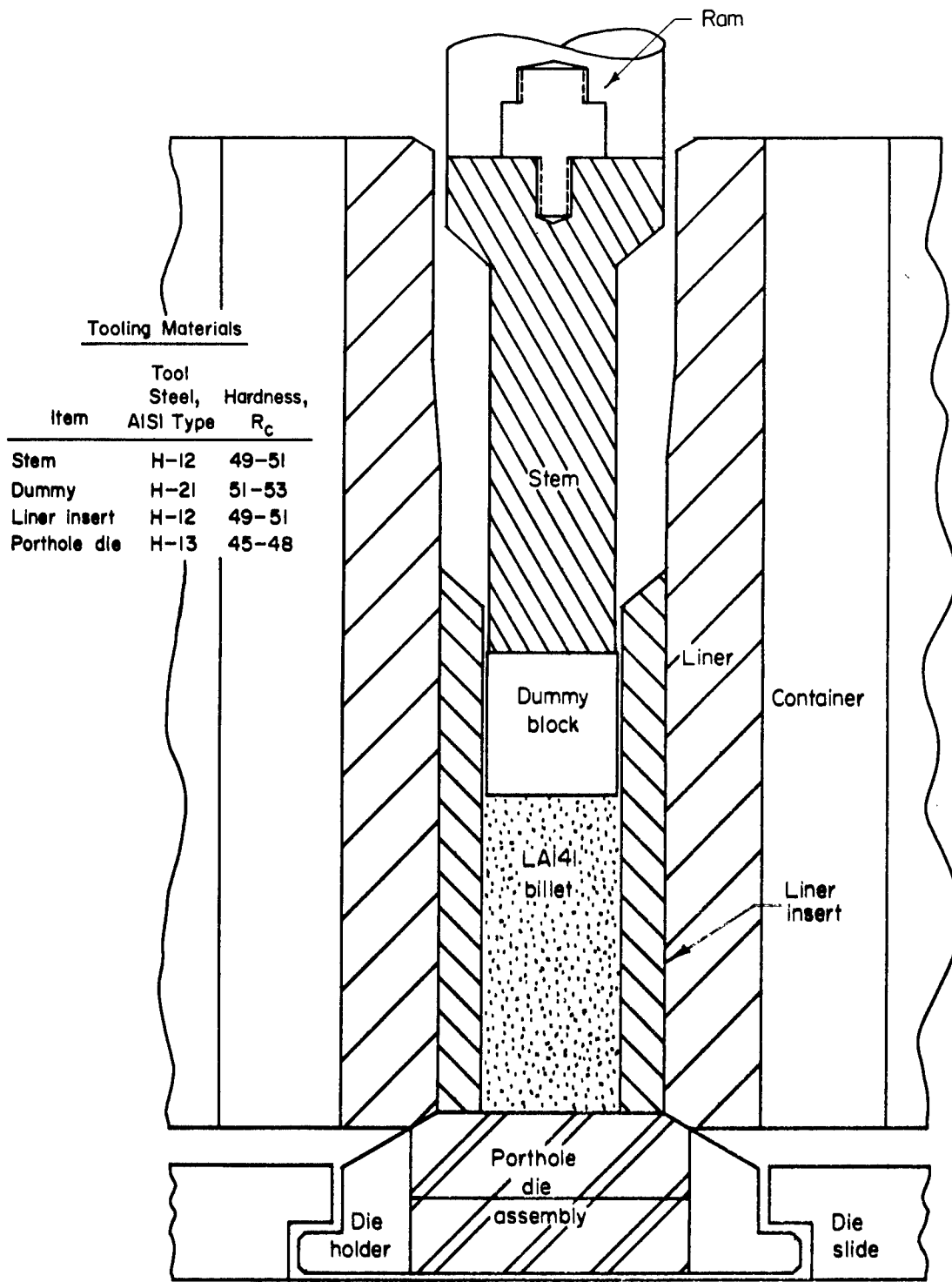

Scale: 6" = 1'

A-44150

FIGURE 7. TOOL ASSEMBLY FOR EXTRUDING LA141 ALLOY THIN-WALLED TUBING ON BATTELLE'S 700-TON EXTRUSION PRESS

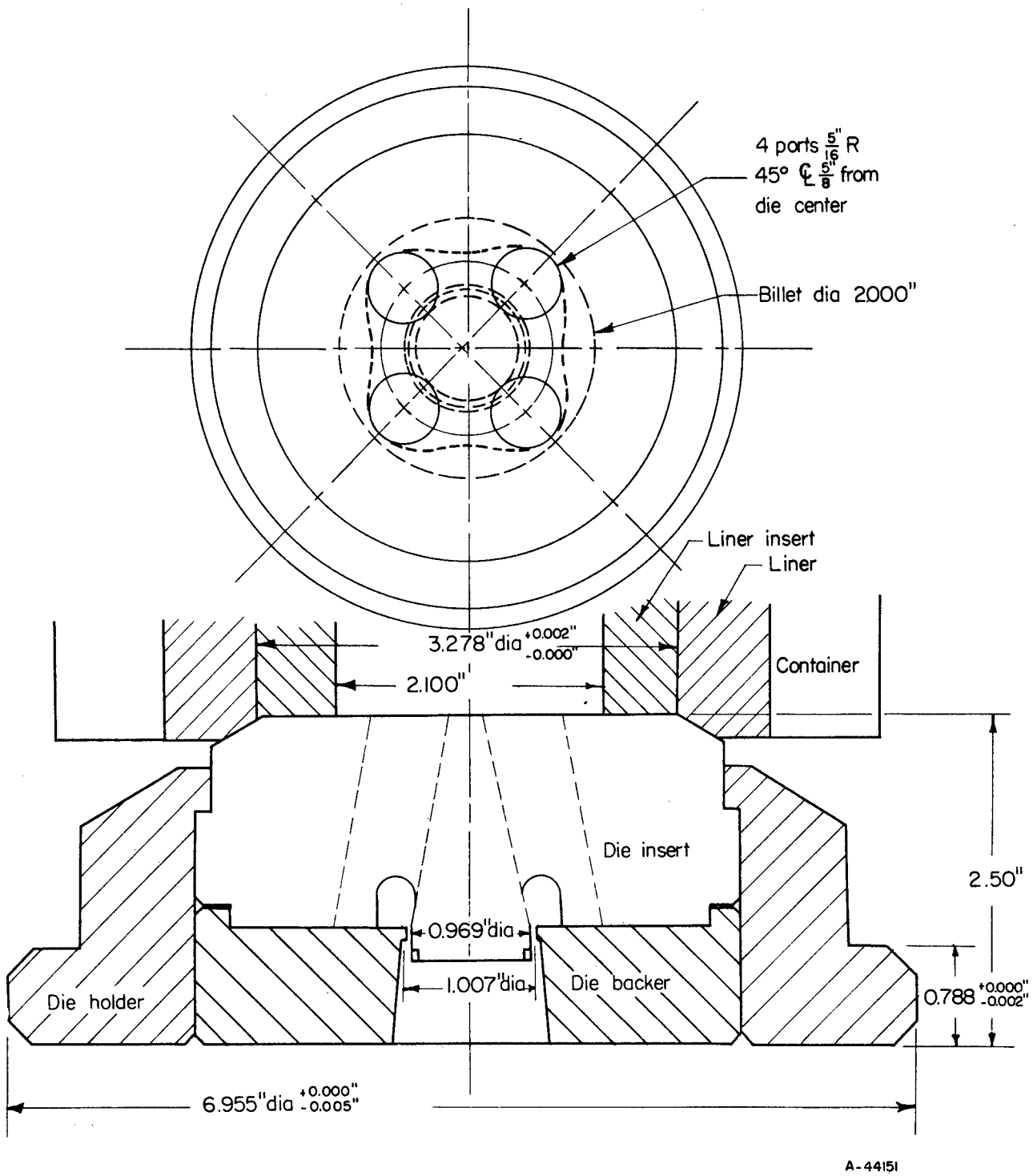

FIGURE 8. DESIGN OF PORTHOLE DIE FOR EXTRUSION OF LA141 TUBING

Die Material: AISI Type H-13; heat treated to 45/48 R<sub>c</sub>.

TABLE 3. DATA FOR EXTRUSION OF LA141 THIN-WALL TUBING

Trial	Billet Length, in.	Center Splits(a)		Extrusion Temperature, F		Ram Speed, ipm		Tube Extrusion Speed, fpm		Extrusion Pressure, 1000 psi		Extruded Length, ft	Comments	
		Billet Nose	Billet Rear	Billet	Container	Die	Break-through	Runout	Break-through	Runout	Break-through			Runout
1	4-1/4	✓		500	500	500	500	0.25	0.25	1	173	173	1/2	Too cold
2	4		✓	600	600	600	600	0.23	0.34	0.75	173	173	14	--
3	5		✓	600	600	600	600	0.23	0.51	1.75	173	173	16	--
4	5-3/4			600	600	600	600	0.23	0.75	3	173	173	25	--
5	5-3/4		✓	600	600	600	600	0.23	0.67	0.75	173	173	20	--
6	5-3/4		✓	650	600	650	600	0.23	0.83	--	--	--	25	--
7	5-3/4		✓	650	600	600	600	0.28	0.28	--	--	--	20-1/2	Poor ovalness, torn Heavy die lines
8	5-3/4		✓	650	600	600	600	0.18	0.67	--	--	--	20	Ditto
9	5-3/4		✓	650	600	600	600	0.18	0.67	--	--	--	20	"
10	5-3/4		✓	650	600	600	600	0.18	0.67	--	--	--	20	"
11	6			650	600	650	600	0.18	0.67	--	--	--	20	"
12	6		✓	650	600	600	600	--	--	14	150	150	21	Runout too fast to handle
13	6			650	600	600	600	0.18	0.67	0.6	150	115	21	Good tubing
14	6			650	600	600	600	0.18	0.67	0.6	150	115	21	Ditto
15	6		✓	650	600	600	600	0.18	0.67	0.6	150	115	21	"
16	6		✓	600	600	600	600	0.18	0.67	0.6	150	115	21	"
17	6			600	600	600	600	0.18	0.67	0.6	150	115	21	"
18	6		✓	600	600	600	600	0.18	0.67	0.6	150	115	21	"
19	6		✓	600	600	600	600	0.18	0.67	0.6	150	115	21	"
20	6		✓	600	600	600	600	0.18	0.67	0.6	150	115	21	"
21	6		✓	650	500	650	500	0.18	1.25	8	200	173	21	--
22	6		✓	650	650	600	600	1.25	1.25	8	150	100	21	--
23	6		✓	650	650	500	500	1.25	1.25	8	173	100	21	--
24	6		✓	650	650	650	650	0.67	0.67	3.5	188	120	21	--
25	6			650	600	600	600	0.67	1.50	11	127	100	21	Good straight tubing
26	6-1/8			650	600	600	600	0.67	1.50	11	173	115	21	Ditto
27	6-1/8			650	600	600	600	0.67	1.1	3.5	173	115	21	"
28	6			650	600	600	600	0.52	1.1	3	173	110	22-1/2	"
29	6			650	600	600	600	0.52	1.1	3	173	115	22-1/2	"
30	6			650	600	600	600	0.44	1.1	3	188	118	22-1/2	"
31	6		✓	650	600	600	600	0.44	1.1	3.5	173	110	22-1/2	"
32	6			600	650	600	600	0.44	1.1	3.5	130	104	22-1/2	"
33	6			600	650	500	500	0.44	1.1	3.5	170	110	22-1/2	"
34	6		✓	600	650	450	450	0.44	1.1	3.5	159	110	22-1/2	"
35	6			600	650	450	450	0.44	1.1	3.5	170	107	22-1/2	"
36	5-3/8			650	600	650	600	0.52	1.1	3	187	130	22-1/2	"
37	6-1/8			650	600	600	600	0.44	1.1	3.5	187	121	22-1/2	"
38	6			650	600	500	500	0.52	1.1	3	138	98	22-1/2	"
39	6		✓	650	600	400	400	0.52	1.1	3	173	110	22-1/2	"
40	6-1/8		✓	650	600	400	400	0.52	1.1	3	173	110	22-1/2	Oxide from center split in billet present in end weld

TABLE 3. (Continued)

Trial	Billet Length, in.	Center Splits(a)		Extrusion Temperature, F		Ram Speed, ipm		Tube Extrusion Speed, fpm		Extrusion Pressure, 1000 psi		Extruded Length, ft	Comments	
		Billet Nose	Billet Rear	Billet	Container	Die	Break-through	Runout	Break-through	Runout	Break-through			Runout
41	6			650	600	450	0.52	1.1	3	7	185	115	22-1/2	Good straight tubing
42	6-1/8			650	600	450	0.52	1.1	3	7	185	107	22-1/2	Ditto
43	6	✓		650	600	450	0.52	1.1	3	7	196	110	22-1/2	"
44	6-1/8			650	600	450	0.52	1.1	3	7	185	110	22-1/2	"
45	6	✓		650	600	450	0.52	1.1	3	7	179	115	22-1/2	"
46	5-3/4	✓		650	600	450	0.52	1.1	3	7	--	101	22-1/2	"
47	6			650	600	450	0.52	1.1	3	7	--	--	22-1/2	"
48	6			650	600	450	0.52	1.1	3	7	--	--	22-1/2	"
49	6-1/4			650	600	450	0.52	1.1	3	7	--	--	22-1/2	"
50	6-1/4			650	600	450	0.52	1.1	3	7	--	--	22-1/2	Split tube
51	6-1/4			650	600	450	0.52	1.1	3	7	--	--	22-1/2	"
52	6-1/8	✓		650	600	350	0.44	0.44	--	--	200	150	--	Die froze, tube scrapped

(a) Check marks (✓) indicate center splits present.

The use of a porthole die precluded cleaning the die between each push since there was no mechanical method available for clearing the die of extruding material. As a result, each billet was extruded until only a 1/4 to 1/2-inch-thick butt remained. This butt was then sheared off flush with the die. The container was reseated on the die and the next billet was extruded. As subsequent discussion will show, no difficulties with end welding were apparent with this technique of semicontinuous extrusion. Design of the porthole die is shown in Figure 8.

### Extrusion Results

Approximately 1150 feet of LA141 tubing (43 pounds) was extruded. Tube lengths were limited to 10 to 12 feet maximum because of the dimensions of the pit under the extrusion press.

The extruded tubing was subsequently inspected and all obvious defects (holes, blisters, etc.) were cut out. Defective material was weighed before being scrapped and this amounted to 3.5 per cent of the total weight of tubing produced. Ultimately, 36 pounds of tubing were shipped to the Sponsor.

Inspection of the extruded tubing showed the following:

- (1) Exterior and interior surfaces were good but light die lines were present generally as shown in Figure 9. Exterior surface finish measured 20 to 50 microinches, average.
- (2) Random measurements of ovalness showed about 0.002 to 0.003-inch difference between the maximum and minimum measurements of the outside tube diameter.
- (3) Random measurements of the outside diameter showed a spread from 0.993 to 1.007 inches in diameter.
- (4) Random measurements of wall thickness showed a variation from 0.018 to 0.025 inch. Most of the tubing showed a 0.022-inch-wall thickness. In general, the higher the speed of extrusion, the thinner the wall thickness obtained.
- (5) Circumferential rings on the tubing surface characterized by an increased OD dimension were the result of stopping and restarting extrusion for each new billet. Examination of the areas immediately behind each "ring" showed good tube soundness and no difficulty from end welding of one billet to another.
- (6) The center splits in the billet stock caused no apparent difficulty with the exception of Billet 40, in which oxides in the center split flowed into the end welds and produced defects in the tubing.



N95066

FIGURE 9. CLOSEUP OF A TYPICAL SECTION OF 1-INCH-OD BY 0.022-INCH-WALL  
LA141 EXTRUDED TUBING

OD surface finish of 20 to 50 microinches, average.

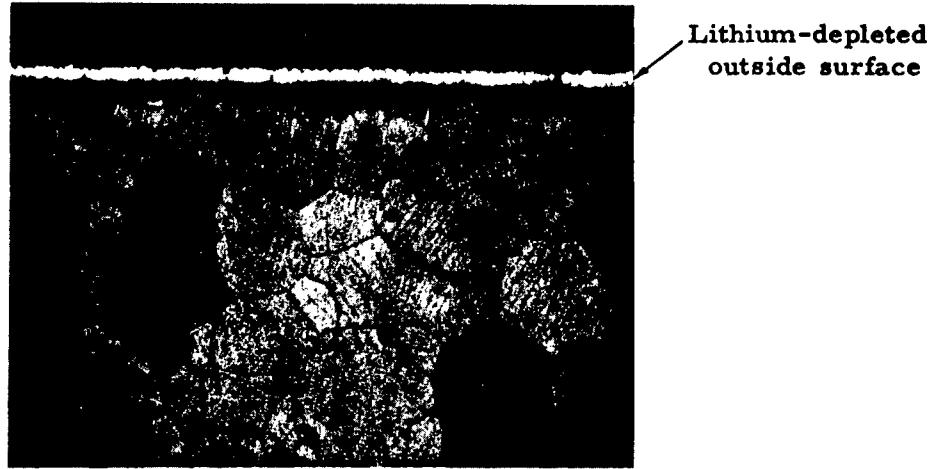

250X

N95952

a. Portion of Cross Section Showing Lithium-Depleted Surface Skin

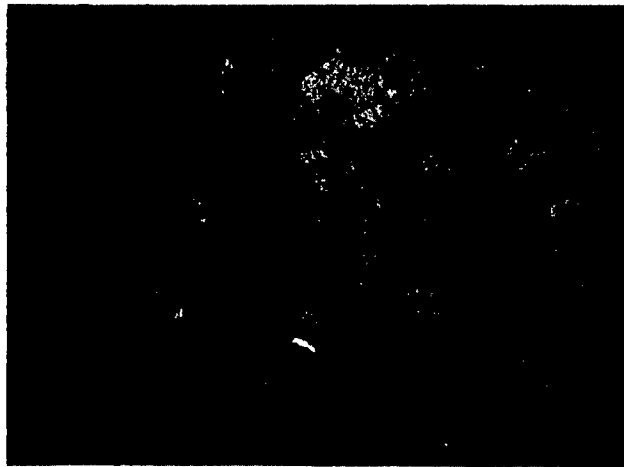

250X

N95952

b. Transverse Cross Section Showing Partially Recrystallized Microstructure

FIGURE 10. EXTRUDED LA141 TUBING

Based on the postextrusion inspection and the data presented previously in Table 3, the best extrusion conditions are believed to be:

- |                           |   |
|---------------------------|---|
| (1) Billet temperature    | 600-650 F                                     |
| (2) Container temperature | 600 F   |
| (3) Die temperature       | 450-500 F                                     |
| (4) Extrusion speed       | 3-3.5 fpm (breakthrough)<br>7-11 fpm (runout) |

Metallographic examination of the microstructure of the extruded tubing showed:

- (1) A lithium-depleted skin on the outside surface about 1 mil thick (see Figure 10a). A similar skin about 1/2 mil thick was present on the inside surface.
- (2) A partially recrystallized grain structure (see Figure 10b). The unrecrystallized areas were found generally in the center of the tube cross section.

Several pieces of as-extruded tubing which split longitudinally during extrusion were flattened and cold rolled on a 1-5/8 by 6-inch four-high rolling mill. One piece was rolled successfully to 0.0015-inch-thick foil; a second to 0.0010-inch strip. This work suggests the feasibility of producing these alloys in foil form.

## METAL-REMOVAL STUDIES

### Machinability

A constant-pressure machinability test was used to determine the relative machinability of LA141 alloy and 2024 aluminum alloy. Prior to a discussion of the results, a description of the constant-pressure test and a definition of the various terms used in evaluating results is included to provide a background for the test results. The lathe test is based on the fact that materials of different machining characteristics cut at different rates when surface speed, depth of cut, and tool geometry are kept constant, and a fixed pressure is applied to the tool.

The lathe is of standard design with 16 spindle speeds ranging from 24 to 1000 rpm. The constant pressure, which produces the feed, is controlled by a weight-and-pulley system which turns the handwheel of the lathe and moves the carriage.

The lateral movement of the carriage is measured by a roller chain-and-sprocket assembly attached to the carriage. Rotation of this assembly turns a cogwheel which, in turn, closes an electrical circuit after each 0.2 inch of carriage travel and rings a bell. The number of revolutions of the spindle during each 0.2 inch of carriage travel is indicated by a counter geared to indicate every second revolution of the spindle.

Thus, the readings obtained in each test correspond to the number of spindle revolutions during 0.1 inch of tool travel.

In a typical test, a series of bars, including an arbitrary standard, are each tested several times, each test consisting of five to ten 0.2-inch cuts. The materials are tested in a different order in each series, to compensate for tool wear during machining.

The readings obtained for each individual test are averaged to give an "R" value which is the average number of spindle revolutions occurring during 0.1 inch of tool travel. These "R" values are again averaged for all tests made on a given material, giving a final "R" value to be used for comparison with the standard.

For comparative purposes, a machinability index called "M" is used, which is defined as the ratio of "R" values, or

$$M = \frac{\text{"R" Standard}}{\text{"R" Unknown}} \times 100.$$

The standard bar (2024-T351 alloy in this case) is considered, arbitrarily, to have an "M" value of 100; all other materials then have "M" values of some percentage of the standard "M" value. Thus, a bar with an "M" rating of 50 machined only half as well as the standard.

The 7/8-inch round 2024-T351 bar stock was purchased from a local commercial supplier. The 7/8-inch round LA141 bar stock was extruded on this project during the production of the LA141 thin-walled tubing. The extruded LA141 material was not straightened so both alloys were turned down to 0.840-inch-diameter stock to provide straight test material.

The following set of conditions was used for both alloys:

Spindle speed	760 rpm
Bar diameter	0.840 inch
Depth of cut	1/8 inch
Thrust force	40.5-79.5 pounds
Tool geometry	5-degree back rake angle 10-degree front relief angle

Cobalt high-speed steel (Firthite) throwaway inserts were used as cutting tools on all machinability tests.

Table 4 contains the results of the machinability studies. A plot of rate of feed  $\left(\frac{0.1}{R}\right)$  versus the thrust force is shown in Figure 11.

TABLE 4. CONSTANT-PRESSURE MACHINABILITY TEST DATA  
FOR LA141 AND 2024 ALLOYS

Alloy	Hanger Weight, lb	Thrust Force(a), lb	Number of Tests	Average "R" Value	Feed, in./rev	Machinability Index
2024-T351	2	40.5	5	52.9	0.00192	100
	2-1/2	47.0	8	54.3	0.00184	100
	3	53.5	5	49.2	0.00203	100
	3-1/2	60.0	2	47.0	0.00213	100
	4	66.5	2	34.3	0.00292	100
	5	79.5	--	--	--	100
	6	92.5	1	21.1	0.00475	100
LA141	2	40.5	4	93.2	0.00107	57
	2-1/2	47.0	10	67.2	0.00149	81
	3	53.5	--	--	--	79(b)
	3-1/2	60.0	2	58.5	0.00171	81
	4	66.5	3	19.3	0.00519	178
	5	79.5	2	9.2	0.01089	286(b)
	6	92.5	1	Too fast to record	--	--

(a) Thrust force = [hanger weight + pan weight (1.12 lb)] x 13 mechanical advantage.

(b) Interpolated values based on the curves in Figure 11.

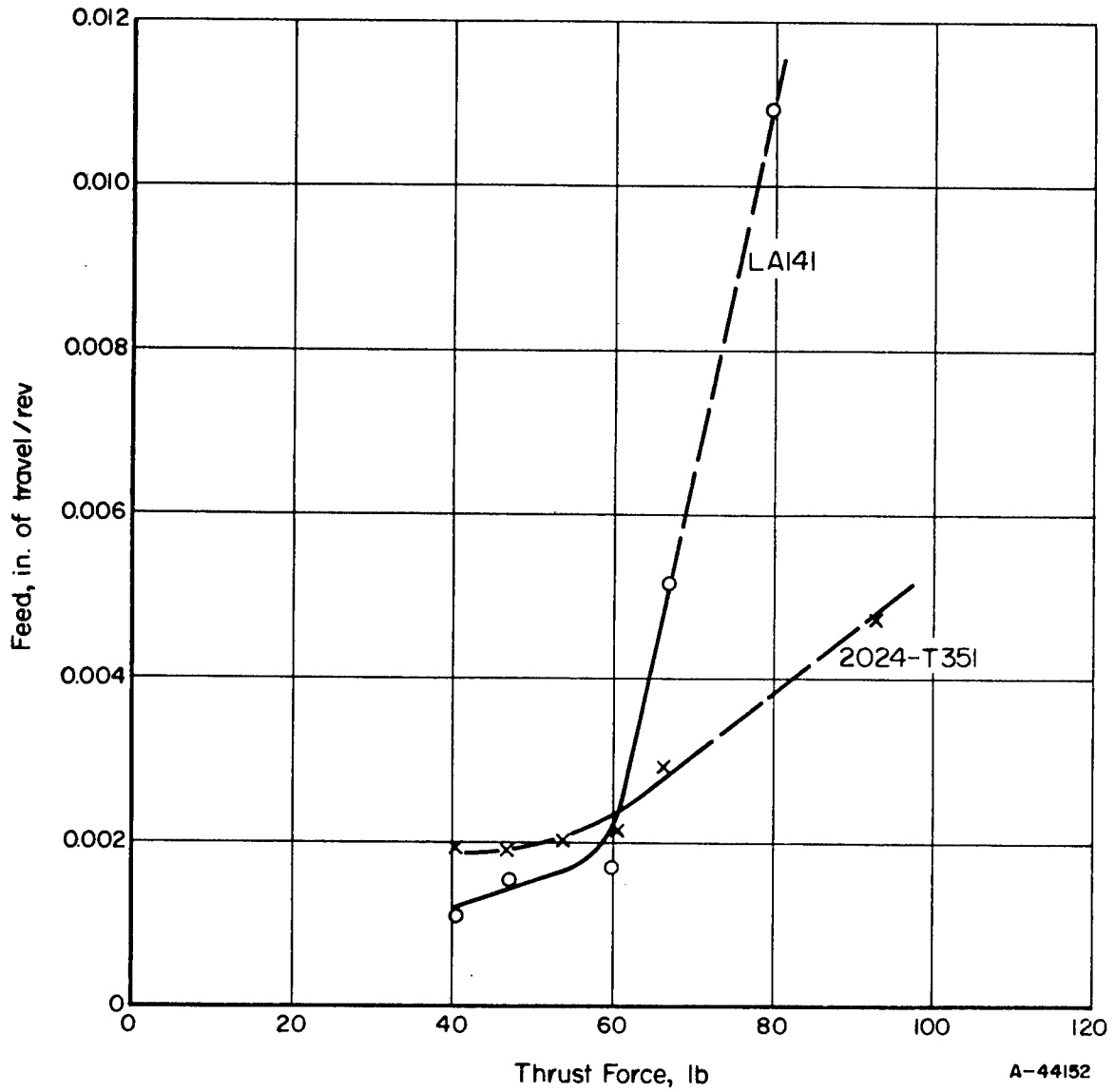

FIGURE 11. EFFECT OF THRUST FORCE ON THE RATE OF FEED FOR LA141 AND 2024 ALUMINUM ALLOY IN CONSTANT-PRESSURE LATHE TEST

As the data show, with increasing rates of feed, the machinability of LA141 surpasses that of the 2024 alloy. Due to the limited number of tests which were performed at the higher rates of feed the projected curves in Figure 11 would require additional tests for verification. However, the fact that very little scatter occurred in the 5 to 10 readings taken in each test at these feed rates would indicate that good duplication of the present data could be realized.

Machinability evaluation studies were not made for LA91 alloy. There is little doubt that this alloy would have a rating quite comparable to that of LA141.

### Chemical Milling

Chemical milling is a commercially used method for selectively removing metal to shape a part and reduce its weight. This process was investigated briefly in the present project to ascertain the feasibility of chemical milling of magnesium-lithium alloys.

Most of the experimental work was done with the LA141 alloy, although enough work was done with LA91 to assure that the two alloys responded similarly. Small sheet specimens about 4 by 5 by 0.060 inch were used. For this investigation areas not to be chemical milled were masked with pressure-sensitive plastic tape. In production, the magnesium-lithium alloys could be masked by comparable techniques for chemical milling of aluminum.

The LA91 alloy reacted slower than did the LA141 alloy. Table 5 contains data on metal-removal rates for acid mixtures. The more concentrated phosphoric acid solutions had rates of less than 1 mil (0.001 inch) per minute. Sulfuric acid solutions were considerably more reactive and gave much higher rates, probably too high to be practical.

The Wyandotte 1066A compound, used with sulfuric acid for etching magnesium alloys, had a rate (1.1 mils per minute) which should be controllable for production use. However, this mixture produced a surface which was not smooth, but appeared as a series of craters. Both the sulfuric and phosphoric acid solutions produced a smooth surface. All the chemical-milled surfaces tarnished after exposure to air.

Figures 12, 13, and 14 are photographs of 4 by 4- or 4 by 6-inch specimens of chemically milled LA141 alloy etched with phosphoric acid, sulfuric acid, and the Wyandotte etchant, respectively. Figure 15 shows panels of LA141 and LA91 alloy masked and milled to demonstrate the ability of the etchants to produce uniform etching rates and adequate undercutting.

Although the work described has been very limited, it can be concluded that:

- (1) Chemical milling of magnesium-lithium-aluminum alloys can be accomplished in phosphoric or sulfuric acid solutions.
- (2) Selection of acid strengths and temperature will depend on physical size of parts and the amount of material to be removed so that convenient etching rates can be selected.

TABLE 5. CHEMICAL-MILLING RATES FOR LA141 AND LA91 ALLOY

Alloy	Solution	Temperature, F	Milling Rate, mil/minute/side
LA141	Phosphoric acid (85 per cent by weight)	70	0.1
LA141	Phosphoric acid (85 per cent) - 1 volume Water - 1 volume	78	0.4
LA141	Phosphoric acid (85 per cent) - 1 volume Water - 9 volumes	110	3.5
LA141	Phosphoric acid (85 per cent) - 1 volume Sulfuric acid (96 per cent) - 1 volume Water - 18 volumes Magnesium sulfate 20 g/l	95	1.85
LA141	Wyandotte 1066A 2.1 lb/gallon Sulfuric acid 5 N	85	1.1
LA141	Sulfuric acid 5 N	120	22
LA141	Sulfuric acid (96 per cent) - 1 volume Water - 19 volumes	92	13
LA91	Sulfuric acid (96 per cent) - 1 volume Water - 19 volumes	85	6



N94171

FIGURE 12. LA141 ALLOY CHEMICALLY MILLED IN 10 PER CENT PHOSPHORIC ACID SOLUTION

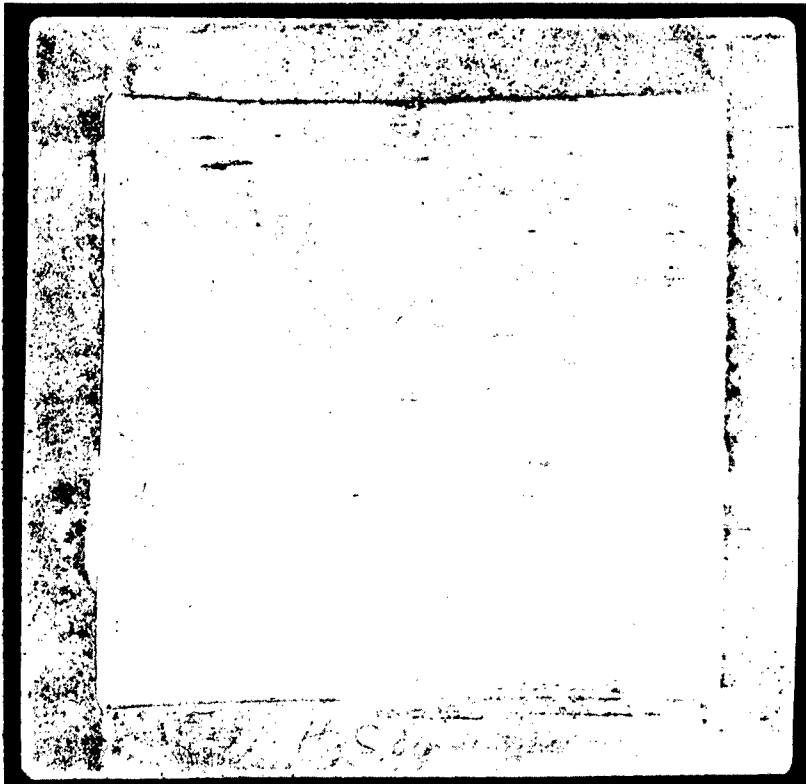

N94172

FIGURE 13. LA141 ALLOY CHEMICALLY MILLED IN 5 N  
SULFURIC ACID SOLUTION

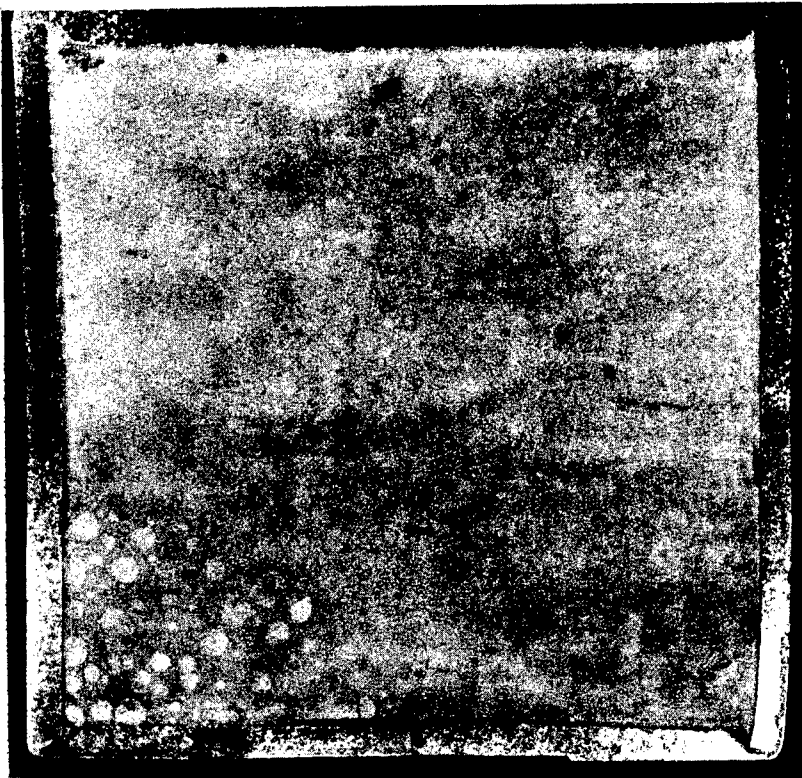

N94173

FIGURE 14. LA141 ALLOY CHEMICALLY MILLED IN WYANDOTTE  
MAGNESIUM ETCHING SOLUTION



N93107

FIGURE 15. CHEMICALLY MILLED MAGNESIUM-LITHIUM ALLOYS ETCHED IN DILUTE SULFURIC ACID SOLUTIONS (5 PER CENT BY VOLUME)

- (3) Appropriate masking materials and methods of application will have to be selected before commercial use is made of chemical milling.

### ELECTROPLATED COATINGS

Surface coatings were desired on the magnesium-lithium-aluminum alloys (LA91 and LA141) that could provide corrosion protection and a heat-reflective surface. The uncoated alloys, when exposed to air with 100 per cent relative humidity at 95 F for 30 days, have been shown to corrode extensively at a rate of  $8 \pm 1.3$  mg/sq dm/day. Anodized coatings (Dow 17) reduced these corrosion rates by a factor of 3-16, depending upon the anodizing voltage, sealing, and the lithium content of the alloy. Corrosion products on the alloy ranged from a thin, white film to a crust-type corrosion product. The latter product was formed on the uncoated alloy surface.

Reported\* procedures for electroplating on magnesium were not directly applicable to the magnesium alloys containing 9 to 14 per cent lithium and 1 to 2 per cent aluminum. Reported\*\* information discussed a displacement tin coating on magnesium alloy LA141 as a primer base for organic coatings. No reports for electroplating on the lithium-aluminum-containing alloys were found.

Two alloys, LA91 and LA141, were considered in the present project. The alloy LA141 was used, for the most part, because any process worked out for the 14 per cent lithium alloy presumably would be adaptable to the alloy containing 9 per cent lithium.

The initial batch of alloy showed gross surface imperfections and inclusions throughout the alloy. These surface defects prevented the application of an adherent, uniform, electroplated coating. A second alloy material (LA141), much improved, has been rolled from cleaner alloy stock and was relatively free of gross surface scale. This material had been burnished with steel wool and water to remove surface scale.

A third material (LA141) was the same alloy stock as the second material. The descaled, as-rolled sheet was heated in air for 1 hour at 425 F to oxidize the lithium-rich alloy phases. Subsequent burnishing with water and steel wool removed the surface oxides.

Satisfactory electroplated coatings were produced on both of the latter two materials. Limited attempts to improve the first material were abortive.

### Chemical Prefinishing and Activating

Chemical prefinishing to remove about 1 mil of the surface metal was accomplished by immersion of the alloy surface for about 5 minutes in phosphoric acid (85 per cent  $H_3PO_4$ ) at room temperature (75 per cent  $\pm 10$  F). The prefinished surface was brightened and smoothed but did not take a uniform zinc film (zincate).

\*DeLong, H. K., "Plating on Magnesium by Electrodeposition and Chemical Reduction Methods", 48th Annual Proceedings of American Electroplaters' Society (1961).

\*\*Glesner, C. W., DeLong, H. K., "Protective Coatings on Magnesium Alloys Intended for Use on Components for Airborne Vehicles", Final Report on Contract DA 20-018-ORD-19650 (July 1, 1960).

Chemical activation of the prefinished alloy surface for adherent zinc coating was accomplished by a 1-minute immersion in a phosphoric acid ammonium bifluoride solution (4.4 N  $\text{H}_3\text{PO}_4$ , 2 M  $\text{NH}_4\text{FHF}$ ), rinsing, a 1/4-minute immersion in dilute hydrochloric acid solution (about 0.3 N HCl) and rinsing prior to immersion in the zincate solution. The alloy surface after the first activation was often coated with a gray to black smut. The second activation treatment produced a bright and active surface which was receptive to the zincate treatment.

#### Zincate Activation

Prior to electroplating on magnesium, a thin (<0.1 mil) zinc coating is produced on the active alloy surface. The zincate solution was one conventionally recommended for preparing magnesium alloys for plating:

Tetrasodium pyrophosphate ( $\text{Na}_4\text{P}_3\text{O}_7 \cdot 10\text{H}_2\text{O}$ )	200 g/l
Zinc sulfate ( $\text{ZnSO}_4 \cdot 7\text{H}_2\text{O}$ )	40 g/l
Potassium fluoride ( $\text{KF} \cdot 2\text{H}_2\text{O}$ )	10 g/l
Potassium carbonate ( $\text{K}_2\text{CO}_3$ )	5 g/l
Temperature	$190 \pm 5$ F
pH	$10.0 \pm 0.2$ (electrometric)
Time	5 minutes

Immersion time and temperature for the zincate treatment were investigated to a limited extent. Although the alloy appeared to be much more chemically active than conventional magnesium alloys, lower temperatures (<178 F) and shorter immersion times, 1 to 3 minutes, did not produce satisfactory zinc coatings. Higher temperatures (>180 F) are necessary for production of the proper zinc coating.

#### Copper Plating

Copper was deposited over the zinc-displacement coating using a modified cyanide bath, designed for plating on magnesium.

Copper cyanide (CuCN)	26 g/l
Potassium cyanide (KCN)	46 g/l
Potassium hydroxide (KOH)	7.5 g/l
Potassium fluoride ( $\text{KF} \cdot 2\text{H}_2\text{O}$ )	50 g/l
Potassium carbonate ( $\text{K}_2\text{CO}_3$ )	15 g/l

pH	13.0 ± 0.3
Temperature	140 ± 10 F

The adherence of the copper-coated magnesium alloy was indirectly appraised as follows:

- (1) Heating with infrared (150+ F)
- (2) Burnishing with steel wool
- (3) Polishing on canvas wheel
- (4) Shearing
- (5) Prying at cut edge with a knife blade.

Samples prepared and plated as above withstood (1) to (4). One-mil-thick copper coatings, at times, could be peeled (5).

#### Nickel Plating

Semibright nickel (Udylite NC 2) was plated satisfactorily over the copper-coated alloy using conventional techniques. Subsequent polishing of the nickel-coated alloy produced good image reflectivity.

#### Aluminum Plating

Aluminum was plated on the copper-coated alloy using a  $\text{AlCl}_3$ -LiH-ether bath. The aluminum coating when polished showed good image reflectivity.

After 20 hours, the copper-plus-aluminum coating blistered in the low-current-density areas where the copper was thinnest and evidently was penetrated by the aluminum plating bath (during aluminum plating).

These experiments, although limited, demonstrate that electroplated coatings can be deposited on magnesium-lithium-aluminum alloys. It is felt that further development of electroplated coatings, toward specific requirements, should be carried on.

#### BRAZING STUDIES

Research on welding of LA141 and LA91 was originally contemplated for this project. A review was made of reports on welding that have been issued by Lockheed and IBM, in addition to earlier reports from Battelle. Although welding problems still exist, it was concluded that the LA141 alloy has received enough welding research that

it presents no serious difficulties. The same welding techniques used for LA141 also are applicable to LA91 alloy. This does not mean that improved techniques cannot be developed for these alloys, nor that research will not be needed for other magnesium-lithium alloys.

Since only limited funds were available for metals-joining research on this contract, the effort was devoted to an exploration of the feasibility of brazing magnesium-lithium alloys.

Brazing is not used extensively for commercial magnesium alloys. This may reflect the difficulties of obtaining filler metals with the desired melting range, meltability, fluidity, and corrosion properties. Since brazing is of great importance in the aerospace industry, it is likely that there will be a requirement to join magnesium-lithium by this process.

A survey was made on the availability of brazing filler metals for magnesium and its alloys. The latest American Welding Society specifications list two classifications: (1) B Mg-1, which has a brazing range of 1120 to 1160 F, and (2) B Mg-2, which has a range of 1080 to 1130 F.

Samples of the latter alloys\* were obtained from Dow in 1/16-inch-diameter wire and 0.010-inch foil forms. The melting range of LA141 alloy was estimated from the phase diagrams to be about 1050 to 1070 F. There was some doubt, therefore, about the suitability of even the lower melting B Mg-2 class of filler metal for brazing LA141.

Preliminary experiments were made to verify the estimated brazing temperature ranges of the LA141 base metal and the AZ125XA filler metal. Samples of base metal and filler metal were heated in a tube furnace under argon, and the melting temperatures were recorded by means of thermocouples attached to the strips of alloy. The results showed that the LA141 alloy started to melt at about 1040 to 1050 F, which was about the solidus temperature estimated from the phase diagrams. The AZ125XA filler metal started to melt at about 770 F and was completely melted at about 1050 F. The latter temperature is about 30 F below the recommended brazing temperature range.

Several attempts were made to torch braze LA141 to itself, using a lap joint with AZ125XA filler metal. It was found that the base metal melted before the filler metal. It was thought that this may have been caused by nonuniform heating with the oxyacetylene torch. Therefore, several samples were to be furnace brazed at progressively decreasing temperatures, starting at the lower end of the brazing range of AZ125XA filler metal. Two runs were made, one at 1100 F and the other at 1080 F. In both cases, the base metal melted along with the filler metal. Further furnace brazing attempts were discontinued because of fund limitations.

Results of this preliminary investigation indicate that the lowest melting commercial brazing alloys for magnesium melt too high for practical use in joining the magnesium-lithium alloys. It is believed that additional research should be done and that this work should be directed, first, toward developing new brazing filler alloys having melting ranges compatible with the magnesium-lithium alloys.

TGB/ELW/PDF:ims

---

\*The Dow Metal Products Company alloy designation for this alloy is AZ125XA.

APPENDIX A

CORROSION RESISTANCE AND CORROSION PROTECTION OF  
MAGNESIUM-LITHIUM ALLOYS - A REVIEW OF  
THE PRESENT STATE OF DEVELOPMENT

## APPENDIX A

CORROSION RESISTANCE AND CORROSION PROTECTION  
OF MAGNESIUM-LITHIUM ALLOYSIntroduction

The corrosion resistance of magnesium-lithium alloys is superior to what might be predicted for alloys containing relatively high atomic percentages of the active metal, lithium. Actually, the corrosion resistance in some ranges of lithium content is similar to that of commercial magnesium alloys.

Unfortunately, the data available on the corrosion behavior and methods of protecting magnesium-lithium alloys are limited. The purpose of this report is to present the information that is available and to point out the areas in which it is important to obtain additional data.

Part of the information on corrosion behavior reported herein originated from research conducted at Battelle some years ago; most of the information on the corrosion protection of commercial magnesium alloys was obtained from the Dow Metal Products Company. In general, many of the methods of protection for magnesium alloys also are applicable to magnesium-lithium alloys.

The compilation of the material in this report was done as one part of a research project conducted at Battelle for the George C. Marshall Space Flight Center, National Aeronautics and Space Administration.

SummaryCorrosion Behavior of Magnesium-Lithium Alloys

Data on the corrosion behavior of magnesium-lithium alloys are limited. Most of the information in this report is based on research conducted at Battelle and at the Dow Metal Products Company.

Binary magnesium-lithium alloys having about 11 per cent lithium are single-phase, body-centered cubic in structure. These have substantially better corrosion resistance in salt water than do lower-lithium alloys of the hexagonal structure. The 11Li alloy\* is about equivalent in this respect to certain commercial magnesium alloys, e. g. , M1A.

---

\*Compositions are in weight per cent.

Alloys of the LA141 type, that is, body-centered cubic alloys with lithium contents in the range of 13 to 15 per cent and aluminum in the range of 0.5 to 2 per cent, have reasonably good resistance to mild atmospheric corrosion. They appear to be nearly equivalent to AZ31B in this respect. Such alloys have substantially less corrosion resistance in salt water than the 11Li binary alloy, but much better corrosion resistance than complex alloys with large amounts of zinc, cadmium, or silver.

Mg-Li-Al body-centered cubic alloys having up to 2 per cent aluminum appear to have better corrosion resistance than do alloys having higher aluminum contents.

Although there is some evidence that manganese inhibits corrosion in the LA141 type of alloy by removing iron in the melt, the results available in the literature do not appear to be sufficient to permit such a conclusion.

Mg-Li-Zn alloys with about 11 per cent lithium and low zinc content (2 to 5 per cent) have corrosion resistance in salt water about equal to that of the Mg-Li-Al alloys with similar lithium and aluminum levels.

At least one two-phase alloy (Mg-8.7Li-5Al-5Zn) has demonstrated corrosion resistance equivalent to that of commercial AZ31A alloy in long-time exposure to a marine atmosphere.

The effects of minor impurities, e. g. , sodium and iron, on the corrosion behavior of magnesium-lithium alloys are not well documented. It would be expected, and there are limited confirming data, that these elements are very detrimental. However, additional evidence is needed before this can be concluded.

#### Protective Measures for Mg-Li Base Alloys

Although no adequate comparative evaluation has been made of the effectiveness of the many possible protective-treatment systems, in general the following statements can be made.

As with all magnesium alloys, magnesium-lithium alloys must be protected when used in most applications. In general, if other magnesium alloys would need protection, magnesium-lithium alloy would also need protection in the same application.

As with all magnesium alloys, galvanic corrosion from dissimilar metals should be avoided. The usual preventive measures for magnesium alloys must be used.

Conversion coatings originally developed for magnesium usually do not give as good protection on magnesium-lithium alloys. The main factor with the magnesium-lithium alloys is the higher alkalinity at the surface. Because of this, the straight-chromate immersion coatings are not effective on magnesium-lithium alloys.

Heavy anodic coatings, such as Dow 17 and HAE, applied to magnesium-lithium alloys do provide some protection in themselves, but usually the additional protection afforded by the application of an organic coating will be required.

The light fluoride anodic coating provides a good paint base.

The stannate immersion coating provides useful protection unpainted; it also is a good paint base.

It appears that an epoxy primer coat plus either an epoxy or other top coat are probably the best paint systems.

Organotin inhibitors for the primer coat are found to be better than the chromates. Tin dust may be added with the organotin.

Conversion coatings and paint systems other than those listed above may find application in mildly corrosive applications. However, in many cases, the selection of protection systems is difficult because of the lack of comparative data.

### Corrosion Behavior of Magnesium-Lithium Alloys

#### Mg-Li Binary Alloys

It will be helpful in understanding the corrosion behavior of binary magnesium-lithium alloys to refer to the phase relationships shown in Figure A-1. Magnesium solid solutions containing up to about 5.7 per cent lithium are hexagonal in structure; those between 5.7 and 10.3 per cent have a two-phase, hexagonal and body-centered cubic structure; those with greater than 10.3 per cent lithium are single-phase, body-centered cubic in structure.

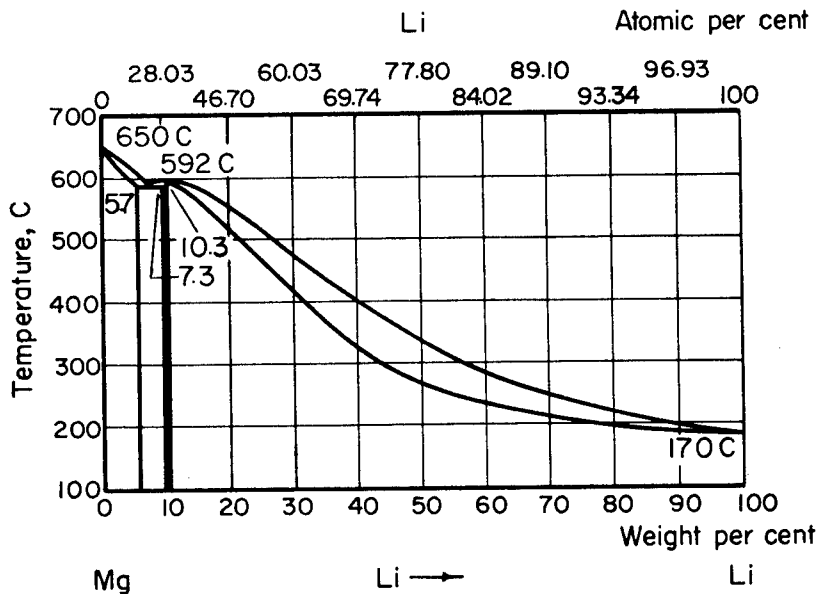

FIGURE A-1. MAGNESIUM-LITHIUM EQUILIBRIUM DIAGRAM<sup>(1)</sup>

Limited experimental data on corrosion rates for binary magnesium-lithium alloys in salt water, humid air, and at elevated temperatures are reported in Table A-1. Photographs of specimens exposed to salt water in the laboratory are shown in Figure A-2. It is indicated that the salt water corrosion resistance of binary alloys containing 2 or 4 per cent lithium was substantially poorer than that of commercial M1A alloy. Increasing the lithium to 9.3 or 11 per cent markedly improved the resistance to salt-water corrosion.

The data suggest that the 11Li alloy is superior to the 9.3Li alloy. This probably reflects the fact that the former has the single-phase structure while the latter has the two-phase structure. It is surprising but very interesting that the single-phase, body-centered cubic alloy with 11Li should have so much better resistance than the single-phase hexagonal alloy with only 2Li.

The higher-lithium alloys displayed corrosion behavior in salt water comparable with or only slightly poorer than that of the commercial magnesium alloys M1, J1, and FS1.

In the humidity tests the 9Li alloy showed corrosion resistance essentially equal to that of M1A alloy. Alloys with 12 and 16 per cent lithium were not so resistant.

#### Mg-Li-Al Alloys

Table A-2 is a compilation of available data on the corrosion behavior of Mg-Li-Al ternary alloys. Considering first the data on the humidity tests made at Battelle, it is seen that alloys containing lithium up to 16 per cent, regardless of aluminum content, had relatively good corrosion resistance. That is, their corrosion rates were about equal to or not much greater than that of the commercial M1A control specimen. On the other hand, alloys containing 20 and 25 per cent lithium with various amounts of aluminum disintegrated in the humidity cabinet. It is not possible, from these data, to define any trends in the effect of the aluminum level on the rate of corrosion in a humid atmosphere.

Looking next at the Battelle results of corrosion by alternate immersion in salt water, as would be expected, this environment is more severe on the alloys than the 100 per cent humidity environment. All of the Mg-Li-Al alloys corroded at faster rates than did the commercial alloys M1 and AZ31. Although it is difficult to make definite conclusions regarding the effects of lithium and aluminum contents, the following observations appear to be valid:

- (1) The alloys with about 14 per cent lithium and about 1 to 3 per cent aluminum have as good as or better resistance than that of any of the magnesium-lithium alloys. (These alloys are body-centered cubic.)
- (2) Alloys with at least 9 per cent lithium (all or predominantly body-centered cubic) have greater resistance than do those with 7.5 or 8 per cent lithium (larger amounts of hexagonal phase in body centered cubic matrix).

TABLE A-1. CORROSION RESISTANCE OF MAGNESIUM-LITHIUM BINARY ALLOYS

Nominal Alloy Composition, per cent	Corrosion Rate(a, b), mcd	Remarks	Reference Number
<u>100 Per Cent Humidity, 95 F, 30 Days</u>			
Mg-16Li	0.18	--	(2)
Mg-12Li	0.10-0.15	--	(2)
Mg-9Li	0.053	--	(2)
Dow MIA	0.034	--	(2)
<u>Indoor Air, 5 Months</u>			
Mg-6Li	--	Resistance similar to other Mg alloys	(3)
<u>Air at 390 F, 40 Hours</u>			
Mg-5Li	--	Slight tarnishing	(3)
<u>Air at 570 F, 40 Hours</u>			
Mg-5Li	--	Heavy attack; black powder formed on surface	(3)
<u>Alternate Immersion, 3 Per Cent NaCl, 95 F, 8 Days</u>			
Mg-11Li	0.57	--	(4)
Mg-9.3Li	0.77	--	(4)
Mg-4Li	4.44	--	(4)
Mg-2Li	4.92	--	(4)
Dow FS-1	0.4	--	(4)
Dow J-1	0.3	--	(4)
Dow M-1	0.5	--	(4)

(a) If an average density of 1.35 g/cc is assumed for these alloys, the average penetration rate can be calculated by the following relation: mils/yr = mcd x 1.06. Uneven attack will produce much higher rates of attack in some areas.

(b) "mcd" = milligrams of metal loss per square centimeter of surface area per day of exposure.

Heat 875  
Mg-10.6Li-4Zn  
Lattice Structure  $\beta$

Heat 690  
Mg-9Li-4Zn  
Lattice Structure  $\beta$

Heat 874  
Mg-11Li  
Lattice Structure  $\beta$

Heat 873  
Mg-9.3Li  
Lattice Structure  $\alpha-\beta$

Heat 872  
Mg-4Li  
Lattice Structure  $\alpha$

Heat 871  
Mg-2Li  
Lattice Structure  $\alpha$

Heat 251  
Mg-1.26Mn  
MLA Alloy  
Lattice Structure  $\alpha$



N-96418

FIGURE A-2. SPECIMENS OF MAGNESIUM-LITHIUM ALLOYS COMPARED WITH A COMMERCIAL Mg-1.26Mn ALLOY FOLLOWING CYCLIC IMMERSION CORROSION TEST IN 3 PER CENT NaCl AT 95 F FOR 8 DAYS

TABLE A-2. CORROSION BEHAVIOR OF Mg-Li-Al TERNARY ALLOYS

Nominal Composition, per cent (Balance Mg)		Corrosion Rate, mcd	Remarks	References
Li	Al Other			
Strip Specimens, Approx. 0.065 x 1 x 7 Inches, 100 Per Cent Humidity, 95 F, 30 Days				
9	0.5 to 2	0.06 to 0.08		(2)
10.4	7	0.05 to 0.06		(2)
14	1.5 to 3	0.08 to 0.11	2.5Al showed lowest resistance	(2)
14.1	1.5	0.035		(2)
16	0.5 to 6	0.07 to 0.24	6Al showed lowest resistance	(2)
20	1 to 10	--	Disintegrated after 30 days	(2)
25	2 to 10	--	Disintegrated after 10 days	(2)
--	--	0.045	MIA commercial magnesium alloy	(2)
1.5Mn				
Strip Specimens, Approx. 0.065 x 1 x 7 Inches, Alternate Immersion in 3 Per Cent NaCl Solution, 48 Hours				
14.1	1	Mg/Li = 6	Solution treated and aged	(5)
14	2	Mg/Li = 6	Ditto	(5)
13.8	3.5	Mg/Li = 6	"	(5)
10.9	0.5	Mg/Li = 8.1	"	(5)
10.8	1.5	Mg/Li = 8.1	"	(5)
10.7	2	Mg/Li = 8.1	"	(5)
7.5	6.5	19.9	"	(5)
7.5	6.5	11.1	"	(5)
8	6.5	11.6	"	(5)
8.5	6.5	17.8	"	(5)
9	6.5	6.27	"	(5)
10	6.5	4.79	"	(5)

TABLE A-2. (Continued)

Nominal Composition, per cent (Balance Mg)		Corrosion Rate, mcd	Remarks	References
Li	Al			
<u>Strip Specimens, Approx. 0.065 x 1 x 7 Inches, Alternate Immersion in 3 Per Cent NaCl Solution, 48 Hours (Continued)</u>				
8	7	17.9	Solution treated and aged	(5)
9	7	4.29	Ditto	(5)
10	7	4.07	"	(5)
8	7.5	8.52	"	(5)
9	7.5	8.64	"	(5)
10	7.5	18.1	"	(5)
8	8	16.3	"	(5)
9	8	2.40	"	(5)
10	8	2.95	"	(5)
8	8.5	4.34	"	(5)
9	8.5	12.2	"	(5)
10	8.5	5.24	"	(5)
--	1	3Zn	Hard-rolled AZ31 commercial alloy	(5)
--	--	1.5Mn	Hard-rolled M1 commercial alloy	(5)
<u>Alternate Immersion in 3 Per Cent NaCl, 7 Days</u>				
13	3	+1.0(b)		(6)
13	4	+0.1(b)		(6)
13	5	+0.1(b)		(6)
13.5	1.5	+0.3 to -0.3(b)		(6)
15	3	+1.0(b)		(6)
15	4	+3.0(b)		(6)
15	5	-0.5(b)		(6)
20	3	+2.0(b)		(6)
20	5	+1.0(b)		(6)

(a) Mills per year = mcd x 1.06 (using 1.35 g/cc as the average density of the alloys).

(b) Weight change, in grams, of uncleaned specimens.

- (3) In general, the alloys having lower aluminum contents (0.5 to 3.5 per cent) have better resistance than do the higher-aluminum alloys. However, this is not consistent.

The data from the alternate-immersion tests made at Armour Research Foundation do not reveal any trends. Since the specimens were not cleaned after removal from the salt solution it is not possible to make any direct comparisons between these results and the Battelle results previously discussed.

Although it has not been confirmed in research at Battelle, it has been reported by the Dow Metal Products Company that small amounts of aluminum improve the corrosion resistance of binary magnesium-lithium alloys. The improvement is said to result from a change in the type of corrosion product from a powdery, nonadherent film to a more adherent form.

It has been observed in research at both Dow and Battelle that the commercial magnesium alloys, in general, have more adherent corrosion products than do the magnesium-lithium alloys. Over long exposure periods the corrosion rates for the commercial alloys decrease with time; those for the magnesium-lithium alloys are more likely to remain constant or decrease much more slowly.

#### Effect of Manganese on Mg-Li-Al Ternary Alloys

Manganese is added to commercial magnesium alloys for improved corrosion resistance. The manganese forms intermetallic compounds with the iron, which is present as an impurity, and precipitates the iron in the molten metal as a sludge. Alloys that contain iron, and which are not so treated with manganese, have poor corrosion resistance.

In the alloying research conducted at Battelle on magnesium-lithium alloys, it was never demonstrated that manganese additions had any effect on corrosion resistance. The Battelle data are not reported here because they are neither extensive nor conclusive.

The Dow Metal Products Company, on the other hand, has conducted extensive experiments on the effects of manganese on magnesium-lithium alloys. They have concluded that additions of about 0.1 per cent manganese are beneficial to corrosion resistance, and used manganese in the heats of LA142 alloy that were made for the M113 armored-vehicle program. Some of the results of the Dow studies on the effect of manganese on the corrosion resistance of LA142 alloys are summarized in Table A-3<sup>(8)</sup>. On the basis of this and other data, Dow concluded that the following percentage compositional limits were necessary to good corrosion resistance in LA142 alloy:

Lithium	- 13.5 maximum
Manganese	- 0.1 minimum
Iron	- 0.005 maximum

After reaching this conclusion, additional heats of the alloy were made which met or came close to meeting these requirements. All of these heats had poor corrosion resistance. The reasons were not apparent, but there was a possibility that lack of

soundness may have been a contributing factor<sup>(8)</sup>. At any rate, the poor corrosion of these heats raised some doubts as to the significance of the compositional restrictions cited above.

TABLE A-3. PARTIAL RESULTS OF CORROSION TESTS ON LA142 ALLOY CONDUCTED AT DOW METAL PRODUCTS COMPANY<sup>(7, 8)</sup>

Alternate Immersion in 3 Per Cent NaCl Solution

Source of Alloy	Number of Alloys in Group <sup>(a)</sup>	Corrosion Rate, mcd		
		Average	Median	90 Per Cent Have Rate Less Than
<u>Alloys With Li &lt; 13.5 Per Cent and Mn &gt; 0.10 Per Cent</u>				
Pilot production	6	2.0	1.5	4.4 (max)
Laboratory	11	4.5	2.1	9.1
Both sources	17	3.7	1.9	8.9
<u>Alloys With Li ≥ 13.5 Per Cent and Mn &lt; 0.10 Per Cent</u>				
Pilot production	9	21	26	37 (max)
Laboratory	12	13	11	32
Both sources	21	17	14	32
<u>All Alloys Tested</u>				
Pilot production	15	14	5.8	33
Laboratory	23	8.0	4.6	20
Both sources	38	11	4.6	29

(a) All alloys given a stabilizing anneal prior to testing.

Other conclusions reached by Dow concerning the salt-water corrosion resistance of LA142 alloy are as follows<sup>(8)</sup>:

- (1) Composition appears to be more important to corrosion resistance than rolling temperatures and other processing variables.
- (2) Copper, in amounts up to about 0.006 per cent, does not appear to be detrimental. However higher contents are not recommended.
- (3) Calcium, in amounts up to about 0.35 per cent, appears to be tolerable.
- (4) As much as 0.005 per cent sodium has no significant effect, and as much as 0.04 per cent Na appears to be tolerable\*.
- (5) Aluminum contents between 0.90 to 2.03 per cent have no significant effects.

\*Payne and Eynon have reported deleterious effects of sodium corrosion resistance in some magnesium-lithium alloys when sodium is present in amounts exceeding 0.002 per cent<sup>(9)</sup>.

- (6) A stabilizing thermal treatment appears to be important. Dow has suggested a treatment of 6 to 12 hours at 350 F. Likewise, stabilization after welding is suggested, specifically 24 hours at 300 F or its time-temperature equivalent.

Willner<sup>(10)</sup>, in reporting application research on the LA141 type alloy for Lockheed Missiles and Space Company stated that salt-spray tests indicated that manganese was not necessary for corrosion resistance. Since manganese apparently causes some difficulty in forming, it was eliminated from the Lockheed specification. The latter is as follows:

Designation	LA141XA*
Lithium	13.00 to 15.00
Aluminum	0.75 to 1.25
Manganese	0.05 maximum
Sodium	0.003 maximum
Iron	0.005 maximum

It is very interesting that Dow found the corrosion resistance of the LA142 alloy to be quite good in the outdoor atmosphere and also in a 100 per cent humidity environment<sup>(8)</sup>. The alloy was stated to be only slightly inferior to AZ31B under conditions of mild weathering. Table 4 shows the results of humidity tests made by Dow on two different heats of LA142 alloy<sup>(8)</sup>.

TABLE A-4. RESISTANCE OF LA142 ALLOY TO CYCLIC HUMIDITY-CONDENSATION TESTING

Alloy	Days on Test	Corrosion Rate, mcd
LA142 <sup>(a)</sup> (Heat A)	42	.028
	68	.027, .023
LA142 <sup>(a)</sup> (Heat A)	42	.020
	68	.013, .013
AZ31B	42	.006
	68	.016, .008
ZK60A-T5	42	.013
	68	.013, .013

(a) Stabilized 6 hours at 350 F.

\*As the names imply, LA141, LA142, and LA141XA are essentially the same alloy with slight variations specified in composition. The nominal composition is Mg-14Li-1Al.

Effects of Elements Other Than Aluminum on  
Corrosion Resistance of Magnesium-Lithium Alloys

The effects of various alloying elements other than aluminum on the corrosion resistance of several magnesium-lithium base materials are shown in Table A-5. The addition of zinc in amounts up to 4 per cent to magnesium-lithium alloys appears to lower slightly the corrosion resistance in salt water alternate immersion exposure. The effect of zinc in a humid environment appears to be insignificant. Other metals have been evaluated in combinations. The data are limited; however, it appears that silver, cadmium, and copper lower the corrosion resistance of magnesium-lithium alloys and that some combinations greatly lower the resistance.

The combined effects of silver and zinc in the salt-water corrosion of some of the complex alloys listed in Table A-5 are summarized in Figure A-3<sup>(4)</sup>.

Alloys of these complex compositions have good mechanical properties at room temperature but gradually lose strength at temperatures of 150 F or higher. Interest in one such alloy\*, which had a tensile strength in excess of 45,000 psi, led to attempts to protect it by cladding. Panels of this alloy were roll-clad with an 11.1Li binary alloy. The sacrificial protection afforded by the latter alloy may be seen in Figures A-4 and A-5. On the other hand the binary alloy has much better resistance than the complex alloy when exposed by itself. This difference in behavior is undoubtedly associated with the type of attack. The binary alloy does not pit appreciably, whereas the complex alloy is extremely susceptible to pitting.

Effect of Marine Atmosphere on Selected Alloys

Some of the most extensive outdoor-exposure tests that have been conducted on magnesium-lithium alloys are described in Reference (11). Panels 4 x 6 x .064 inch of alloys of the alpha-beta type (i. e. , alloys having a mixed hexagonal and body-centered cubic microstructure) were exposed for a period up to 32 months on racks located near the shore at Daytona Beach, Florida. Table A-6 gives the results, including those from Alloy AZ31A, for the same exposure period. The weight-loss curves are shown in Figure A-6, and photographs of the most corrosion-resistant alloys are shown in Figures A-7 and A-8.

The behavior of the Mg-8.7Li-5Al-8Zn alloy is of particular interest, since the alloy showed corrosion resistance essentially equal to that of AZ31A. The notation in Table 6 to the short life of carbon steel is in reference to steel panels exposed at another period on the same racks. This does, however, show that unprotected steel is less resistant than some magnesium-lithium alloys when exposed to a marine atmosphere.

Unfortunately this research was done prior to the time when interest began to be demonstrated in the LA141 type of alloy. It would be desirable to expose the newer alloys to the same test.

---

\*Mg-11.5Li-15Cd-5Ag

TABLE A-5. CORROSION OF MAGNESIUM-LITHIUM ALLOYS WITH ADDITIONS OF OTHER ELEMENTS

Nominal Alloy Composition, per cent (Balance Mg)	Corrosion Rate, mcd
<u>100 Per Cent Humidity, 95 F, 30 Days (2)</u>	
11.7Li-18Zn	0.034
MIA	0.034
<u>Alternate Immersion, 3 Per Cent NaCl, 8 Days (4)</u>	
9.3 Li	0.77
9Li-4Zn	2.81
11Li	0.57
11Li-4Zn	2.83
12.6Li-6Zn-6Ag	18.7
12.3Li-6Zn-4Cd-4Ag	8.2
12.0Li-6Zn-4Cd-6Ag	12.6
12.0Li-4Zn-6Cd-6Ag	8.8
10.9Li-4Zn-4Cd-5Ag	6.4
10.7Li-4Zn-4Cd-6Ag	10.5
10.7Li-4Zn-6Cd-4Ag	4.7
10.5Li-4Zn-6Cd-6Ag	8.3
10.4Li-5Zn-6Cd-6Ag	10.8
10.9Li-3Zn-7Cd-3Ag	2.2
9.0 Li-6Zn-6Cd-6Ag	11.1
10.6Li-4Zn	2.2
Dow FS-1	0.4
Dow J-1	0.3
Dow M-1	0.5
<u>Alternate Immersion, 3 Per Cent NaCl, 7 Days (6)</u>	
13.5Li-3Zn	0.0(a)
13.5Li-5Zn	0.5(a)
13.5Li-7Zn	2.8(a)
12Li-7Zn-1Ag	2.8(a)
12Li-7Zn-2Ag	2.3(a)
12Li-7Zn-3Ag	3.3(a)
12Li-18Cd-1Ag	0.5(a)
12Li-18Cd-2Ag	0.3(a)
12Li-18Cd-3Ag	1.75(a)
12Li-18Cd-1Cu	0.0(a)
12Li-18Cd-2Cu	4.0(a)
12Li-18Cd-3Cu	5.0(a)

(a) Weight loss, in grams, from uncleaned specimens after 7-day exposure.

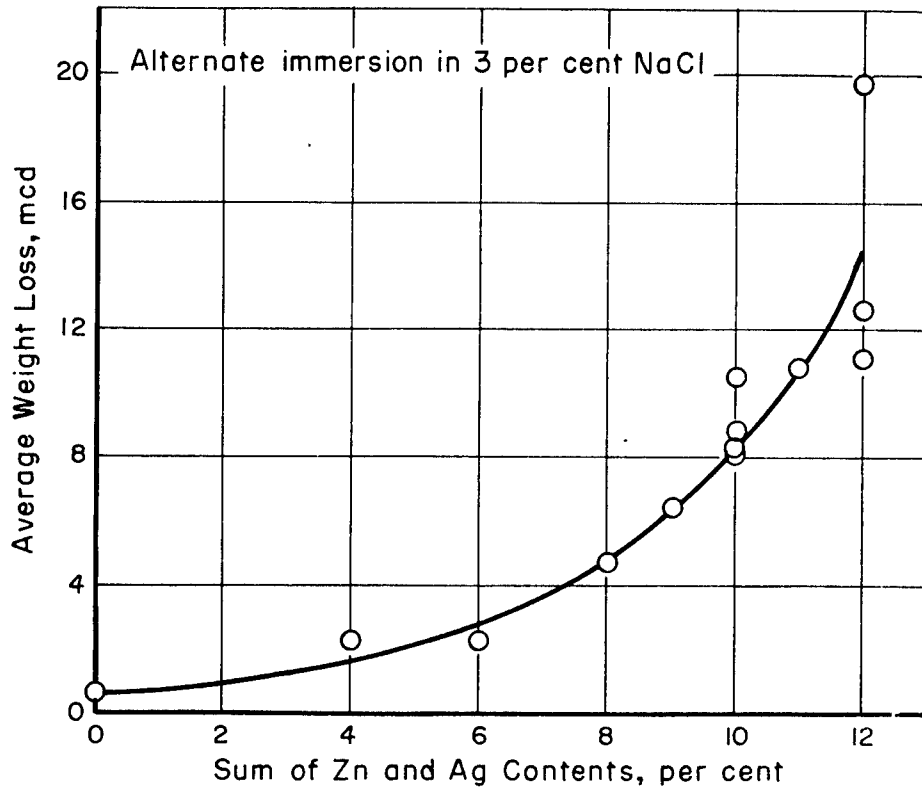

FIGURE A-3. EFFECT OF SILVER AND ZINC ON CORROSION RESISTANCE OF MAGNESIUM-LITHIUM ALLOYS IN SALT WATER

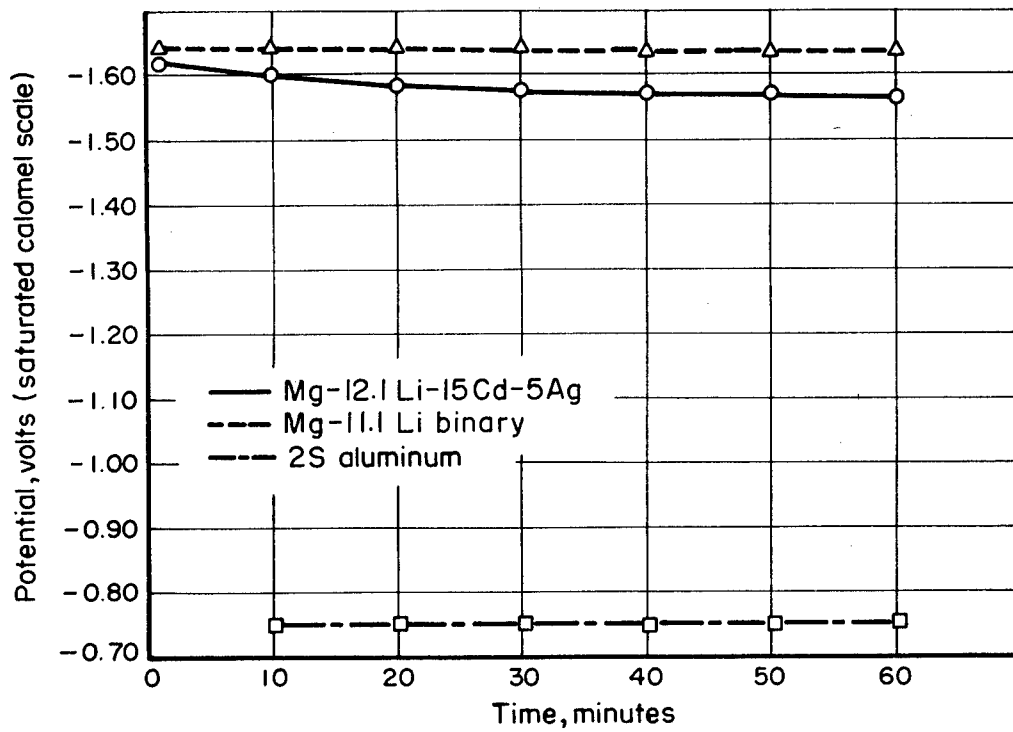
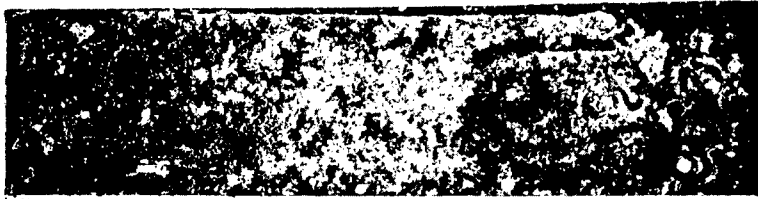
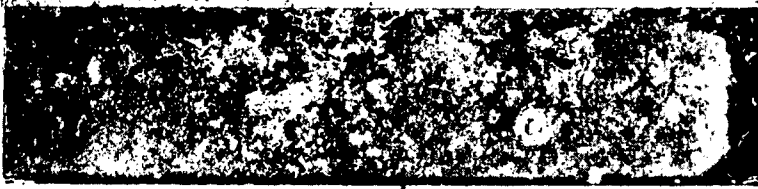

FIGURE A-4. TIME-POTENTIAL VALUES FOR MAGNESIUM-LITHIUM ALLOYS COMPARED WITH ALUMINUM

3 per cent NaCl solution at 95 F.



Binary alloy



Exposed base alloy,  
1/16 inch

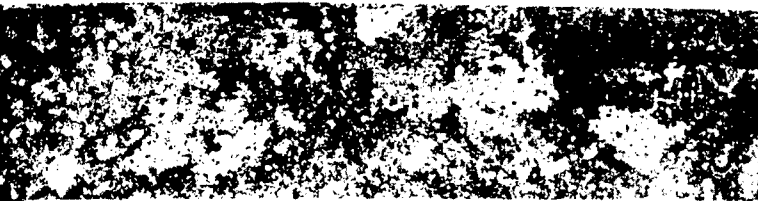

Binary alloy



Exposed base alloy,  
1/8 inch



Binary alloy



Binary alloy

Exposed base alloy,  
1/4 inch



Binary alloy

2X

N96417

FIGURE A-5. RESULTS OF EXPERIMENT TO SHOW THE SACRIFICIAL PROTECTION GRANTED BY THE Mg-11, 1Li BINARY ALLOY TO THE Mg-11, 5Li-15Cd-5Ag BASE ALLOY

Test Conditions: 48 hours in aerated sea water at 95 F.

The amount of cladding exposed is the same in all three experiments.

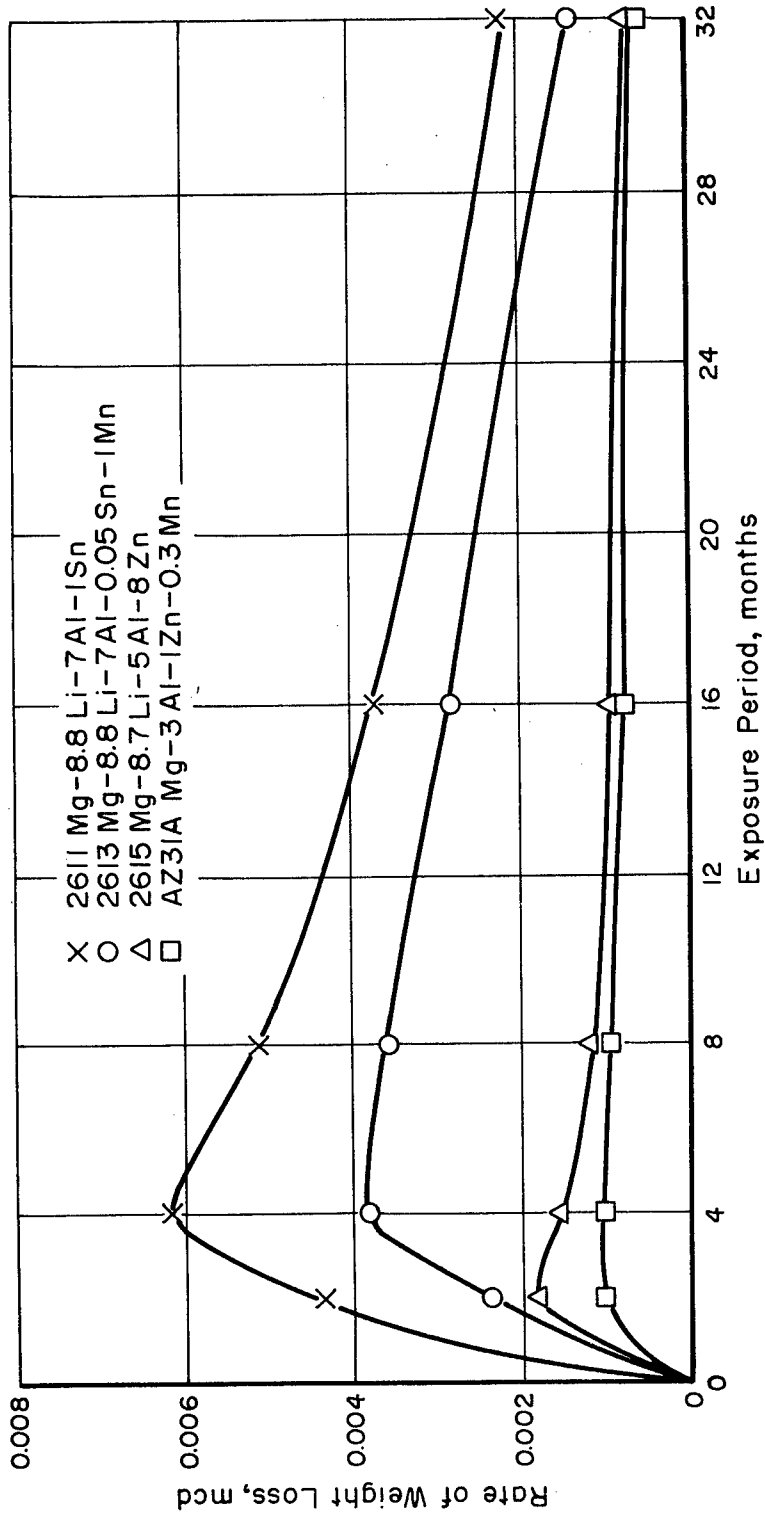
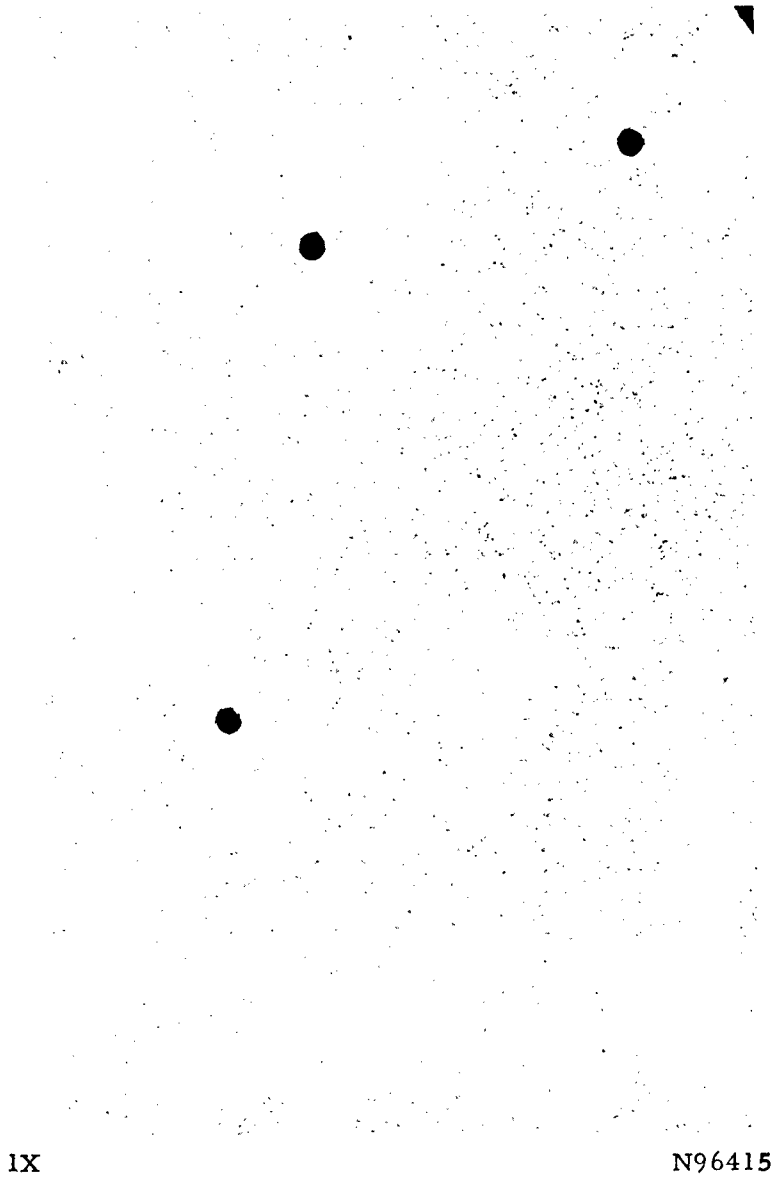

FIGURE A-6. CORROSION RATE, EXPRESSED AS WEIGHT LOSS, OF EXPERIMENTAL MAGNESIUM-LITHIUM BASE ALLOYS COMPARED WITH COMMERCIAL AZ31A ALLOY



IX

N96415

**FIGURE A-7. UNDERSIDE OF PANEL OF THE 8.7Li-5Al-8Zn ALLOY  
AFTER 16 MONTHS' EXPOSURE AT DAYTONA BEACH**

**Corrosion products have been removed.**



1X

N96416

**FIGURE A-8. UNDERSIDE OF PANEL OF AZ31A (Mg-3Al-1Zn) ALLOY  
AFTER 16 MONTHS' EXPOSURE AT DAYTONA BEACH**

**Corrosion products have been removed.**

TABLE A-6. CORROSION OF SELECTED ALLOYS EXPOSED  
32 MONTHS IN MARINE ATMOSPHERE AT  
DAYTONA BEACH, FLORIDA(11)

Alloy Composition	Corrosion Rate, mcd
Mg-8.8Li-7Al-1Sn	.022
Mg-8.8Li-7Al-0.05Sn-1Mn	.015
Mg-8.7Li-5Al-8Zn	.008
AZ31A	.008
Carbon steel	--(a)

(a) Disintegrated in 24 months.

The Mg-8.7Li-5Al-8Zn alloy, or one having a somewhat similar composition, may be of interest to NASA in the future, since it has higher strength than LA141 or LA91.

Protective Treatments Used on  
Magnesium Alloys in General

A number of treatments are in common use for the corrosion protection of magnesium alloys in general. Some of these treatments are not effective on magnesium-lithium alloys. However, the protection afforded by coating systems on magnesium is as follows, ranging from least protective (No. 1) to the most protective (No. 7).

- (1) Light-immersion coating, without paint
  - (a) Chrome pickle, Dow 1 (chromate)
  - (b) Dow-15 and -16 (chromate)
  - (c) Ferric nitrate pickle (chromate, nitrate)
- (2) Light anodic coatings, not sealed, without paint
  - (a) Dow-17 (thin), ac or dc (chromate)
  - (b) Modified Dow-17 (clear) (chromate)
  - (c) Modified HAE coating (thin) (fluoride, manganate, hydroxide)
  - (d) New Chrome (thin) (hydroxide fluoride phosphate)
  - (e) Fluoride anodize (fluoride)
  - (f) Dow-9 (chromate)
  - (g) Manodyz (hydroxide)
- (3) Heavy-immersion coatings, without paint
  - (a) Dichromate treatment, Dow-7 (chromate)
  - (b) RAE, half-hour (chromate)
  - (c) MEL chrome-manganese (chromate, manganate)
  - (d) Irridite 15 (chromate)

- (4) Heavy anodic coatings, not sealed, without paint
  - (a) HAE (thick) (fluoride, manganate, hydroxide)
  - (b) Dow-17 (thick), ac or dc (chromate)
  - (c) CR-22 (fluoride phosphate)
  - (d) New Chrome (hydroxide, fluoride, phosphate)
- (5) Heavy anodic coatings, sealed, without paint
  - (a) Dow-17 (thick) + waterglass sealant (chromate)
  - (b) HAE (thick) + dichromate bifluoride treatment (fluoride, manganate, hydroxide)
- (6) Heavy-immersion coatings, with paint
  - (a) Dow-7 + paint (chromate)
  - (b) RAE, half-hour + paint (chromate)
  - (c) MEL chrome-manganese + paint (chromate)
  - (d) Dow-18 + paint (phosphate, hydroxide)
  - (e) Dow-19 + paint (chromate)
  - (f) Stannate coating + paint (stannate hydroxide)
  - (g) 8 per cent phosphoric acid + paint (phosphate)
- (7) Light or heavy anodic coatings, with paint
  - (a) Dow-17 + paint (chromate)
  - (b) HAE + dichromate bifluoride + paint (fluoride, manganate, hydroxide)
  - (c) CR-22 + paint (fluoride phosphate)
  - (d) New Chrome + paint (hydroxide, fluoride, phosphate)
  - (e) Manodyz + paint (hydroxide)
  - (f) MEL fluoride anodize + Aldrite 950 paint.(fluoride)

There is some question as to the order of the above classification of protective treatments; that is, within the several groupings, no effort was made to arrange the coatings in order. Also there probably is considerable overlapping of adjacent groups. There are other coatings which might be considered; however, those listed above are probably the most used.

If a bright metal surface is desired, only four coatings could be used. These are Dow-15 and -16, ferric nitrate pickle, modified Dow 17, and fluoride anodize, any of which can be further protected with a clear lacquer.

#### Protective Treatments on Magnesium-Lithium Alloys

Of all the possible treatments, those that have been tried on magnesium-lithium alloys are described in the following pages.

It has been shown that some of the potential treatments for producing corrosion-resistant or paint-base conversion coatings are applicable to magnesium-lithium alloys and some are not. The following treatments, which include cleaning and pickling as well as anodic and simple immersion-coating treatments, have been used with success on magnesium-lithium alloys:

- (1) Dow-16 (Data Sheet 24\*)(<sup>12</sup>)
- (2) Phosphoric acid, with neutralization (Data Sheet 22)(<sup>12</sup>)
- (3) Ferric nitrate pickle (Data Sheet 25)(<sup>12</sup>)
- (4) Dow-17 (thin) (Data Sheet 23)(<sup>12</sup>, 2)
- (5) Dow-18 touch-up (Data Sheet 20)(<sup>12</sup>)
- (6) Irridite-15 touch-up (Data Sheet 21)(<sup>12</sup>)
- (7) Nitric acid pickle (Data Sheet 3)(<sup>12</sup>)
- (8) Stannate coating (Data Sheet 1)(<sup>13</sup>)
- (9) HAE (Data Sheet 30)
- (10) Dow-17 (heavy) (Data Sheet 29)(<sup>2</sup>)

The surface treatments which have been tried and found unsatisfactory on magnesium-lithium alloys for any of several reasons are as follows(<sup>12</sup>):

- (1) Dow-1
- (2) Dow-7
- (3) Dow-9
- (4) Dow-10
- (5) Dow-15
- (6) Hydrofluoric acid pickle
- (7) Acetic acid pickle
- (8) Dow-19, touch-up
- (9) Modified Dow-19, touch up.

\*Data sheets are in Appendix B.

Dow-17 Anodic Treatment. The Dow-17 anodic coating has been applied to Mg-Li-Al alloys with favorable results. Data Sheets 23, 29, and 30 describe the procedures for applying these coatings. The Dow-17 thick, Dow-17 thin, and Dow-17 thin sealed coatings have been evaluated by exposure to humid air. The results of these tests are listed in Table A-7(2).

The coatings were somewhat porous. The corroded specimens were covered with a thin white film of corrosion product, while bare specimens were crusted with thick white corrosion products. The anodic coating alone improved the corrosion resistance about 60 to 70 per cent for the thin coating and 80 to 90 per cent for the thick coating. The waterglass sealant did not improve the corrosion resistance of the thin coating and was not tried on the thick coating. After corrosion had taken place and the specimens were removed from the high-humidity medium, the corrosion product and coating tended to spall. This would indicate that alternate wet and dry conditions would be worse than continual high-humidity exposures.

The Dow-17 thin coating has been evaluated in the painted condition<sup>(14, 15)</sup>. Of the coatings tested the Dow-17 coating performed as well as or better than other paint bases.

TABLE A-7. CORROSION RATES OF Mg-14Li-1.5Al AND Mg-9Li-1Al ALLOYS EXPOSED TO 100 PER CENT HUMIDITY AT 95 F FOR 30 DAYS(2)

Alloy Surface Finish	Corrosion Rates, mcd wt gain	
	Mg-14Li-1.5Al	Mg-9Li-1Al
Bare metal	0.103 - .092	.089 - .067
Dow-17 (thin)(a)	.016 - .028	.017 - .022
Dow-17 (thick)(b)	-- - .019	-- - .008
Dow-17 (thin) + waterglass sealant(c)	.017 - --	.013 - --

(a) 30 amp/sq ft; max voltage, 75 volts ac; time, 45 min to 1 hour

Bath: 240 g/liter  $\text{NH}_4\text{HF}_2$ , 100 g/liter  $\text{Na}_2\text{Cr}_2\text{O}_7$ ,  
9 ml/liter 85 per cent  $\text{H}_3\text{PO}_4$

Temperature: 160 to 180 F

(b) Same as (a), except final voltage was 90 volts ac.

(c) 15-minute dip in aqueous solution of 7 oz/gal sodium tetrasilicate at 200 to 212 F, followed by cold-water rinse and air drying.

The New Chrome Anodic Treatment. The New Chrome Anodic treatment is a modification of the HAE treatment. Attempts to apply this coating to Mg-Li-Al alloys at Battelle were not successful. A light-green, low-voltage coating was formed, but the high-voltage, hard coating could not be obtained<sup>(2)</sup>.

Stannate Coating. The stannate coating is usually intended as a paint base, but the coating does provide considerable protection without painting. It is a simple immersion-type coating. The details are given in Data Sheet 1. The treatment produces a coating which is about equal parts metallic tin and magnesium stannate,  $\text{MgSn(OH)}_6$ , and is about 0.0002 inch thick. It has been postulated that a deposit of metallic tin forms on the cathodic areas and magnesium tin hydroxide on the anodic areas [ $\text{MgSn(OH)}_6$ ].

The coating is particularly useful in applications involving dissimilar metals, which otherwise will cause accelerated galvanic corrosion to occur. Galvanic corrosion is greatly reduced by stannate treatment of finished composite metal parts. At the same time that the magnesium part is coated with the complex tin:tin-stannate protective film, the other metals (steel, brass, copper, etc.) are immersion plated with metallic tin. However, the bath is alkaline and attacks aluminum inserts in magnesium-aluminum composite parts. Such parts must be masked properly before introducing them in the bath, or inserts can be assembled after the stannate coating is applied.

The alkaline coating, which is formed on the magnesium-lithium alloys, must be neutralized before painting. This is done by treating the coating in a sodium acid fluoride solution (Data Sheet 2)<sup>(13)</sup>.

Figure A-9 shows three possible flow charts for cleaning, preparing the surface, coating magnesium alloys with the stannate coating, and neutralizing. Alternate Method I is considered to be the best procedure for the LA142 alloy. It uses the nitric acid pickle (Data Sheet 3), which removes the dark-gray or black film characteristic of magnesium-lithium alloys. The disadvantage in employing the nitric acid pickle is that it is not suitable for use after a part is machined to close tolerances because of the large amount of metal removed. In Alternate Method II, the chromic acid pickle (Data Sheet 4) is used. Though not as effective, this method has the advantage of low metal loss in high-tolerance parts. The hydrofluoric acid pickle (Data Sheet 5) serves several purposes: (1) it strips old chromate coatings or stannate coatings and (2) it descales and activates steel inserts and removes smut from other pickle treatments. The details of the alkaline cleaning treatments are given in Data Sheets 6 and 7. The heavy-duty cleaning bath is usually used<sup>(13)</sup>.

Thorough rinsing is necessary in the stannate treatment. Any carry-over of hexavalent chromium from pickling or from previously applied coatings adversely affects the stannate coating bath. Small additions of sodium hydrosulfate ( $\text{Na}_2\text{S}_2\text{O}_4 \cdot 2\text{H}_2\text{O}$ ) help to reduce the chromium to the trivalent form, but better results are had if the chromate ions are excluded. Agitation of the bath is optional and can be done either by mechanical means or by air. Contact of the work with the tank should be avoided to prevent plating of tin on the tank itself. A hot-water final rinse is used to accelerate drying<sup>(13)</sup>.

It should be pointed out that there is potentially a problem in using a tin coating at low temperatures. In the range of -50 F, tin transforms from the white beta phase to the gray alpha phase. This may cause the tin plate to become less adherent. Some transformation of tin electroplates has been shown to occur at -40 F, but salt-spray tests showed little reduction in protectiveness<sup>(14)</sup>.

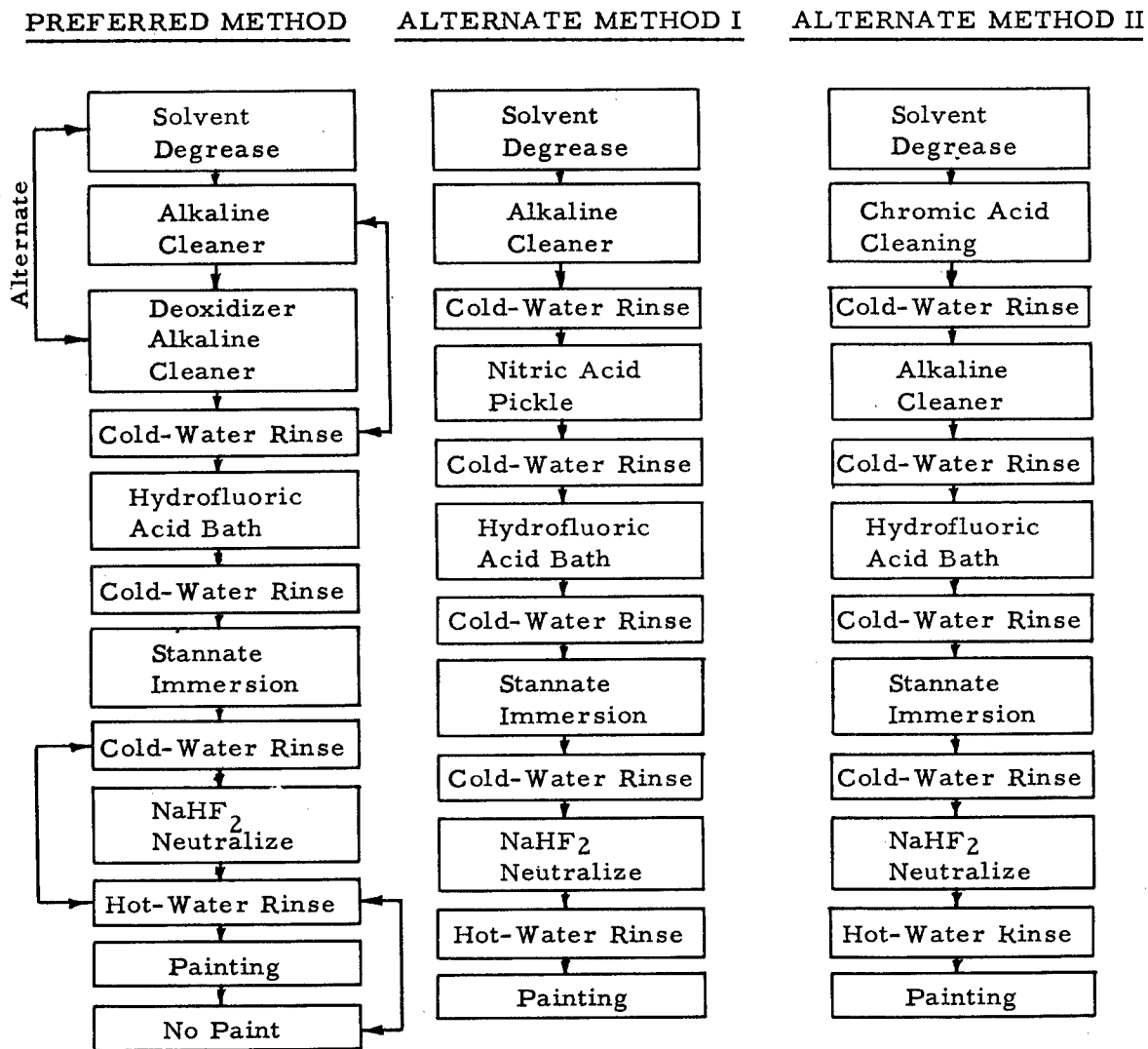

FIGURE A-9. PROCEDURES FOR APPLYING STANNATE COATING(13)

One advantage of the stannate coating is in protecting electrical equipment where electrical contact and grounding are necessary. The surface electrical resistance of magnesium components coated with the stannate coating is of the order of 8 microhm/square inch, which is about equal to that of bare magnesium (7 microhms/square inch). This is low when compared with that of anodized aluminum or anodized magnesium (Dow-17, thin, has a resistance of 74,000 microhms/square inch)<sup>(14)</sup>.

A comparison has been made between the stannate coating and the Dow-17 coating when used on the LA142 magnesium alloy<sup>(14)</sup>. The two coatings were evaluated in both the painted and unpainted conditions. The paint system used was Mil-C-15328, wash primer plus three coats of Truscon Speed Rex chemical and solvent-resisting gray epoxy enamel. Galvanic couples of steel, tin-plated steel, and cadmium-plated steel also were evaluated. Evaluation was by two exposures: (1) WeatherOmeter at 140 F for 650 hours and (2) outdoor rural exposure for 15 months.

In the WeatherOmeter test the over-all corrosion resistance was good, and no significant attack was noticeable on the panel surfaces or at galvanic couple areas of the unpainted panels. Tin-plated fasteners coupled to Dow-17 unpainted panels showed a slight advantage over cadmium plate. However, the best protection resulted from the stannate-treatment of a magnesium panel with steel fasteners. Considerable spalling of the Dow-17 coating occurred during this test. On the other hand the stannate coating was intact<sup>(14)</sup>.

A similar evaluation of painted assemblies showed that good protection was afforded in general and at galvanic couplings. Also, no significant attack was observed at scribed areas where the base metal was exposed. One instance of paint lifting was found, which was attributed to improper neutralization of the stannate coating before painting<sup>(14)</sup>.

In the rural experiments, unpainted test panels with either the Dow-17 or stannate coatings withstood the outdoor exposure very well. There were no signs of galvanic corrosion with bare steel fasteners. The general surface conditions indicated that the stannate coating was superior to the Dow-17 treatment. The breakdown of the Dow-17 coating that occurred was in the form of discoloration and spalling. This form of failure is an indication that this anodizing probably is not so effective on the LA142 alloy as it is on other alloys.

In outdoor exposures, with either damaged or undamaged painted stannate coatings, galvanic-couple protection was very satisfactory. Under-paint corrosion took place on Dow-17 painted panels that were intentionally damaged, indicating a lack of protection of the anodic coating itself.

These findings further indicate that the Dow-17 coating is not so protective for the LA142 alloy as it is for most other magnesium alloys. On the other hand, the stannate coating produces about the same degree of protection on the LA142 alloy as on other alloys<sup>(14)</sup>.

8 Per Cent Phosphoric Acid Treatment. The 8 per cent phosphoric acid treatment was developed for use on the LA142 alloy. The alloy can be dipped in the phosphoric acid, or the phosphoric acid can be brushed on the alloy. It finds application as a

brush-on treatment for large parts which cannot be treated by the Dow-17 or by other anodic or dip processes. The coating acts as a paint base and is nearly as effective as Dow-17 if the base-metal corrosion rate (alternate immersion in 3 per cent NaCl) is low (that is, of the order of 1.0 mcd). The treatment is not so effective as the Dow-17 treatment for alloys with high base-metal corrosion rates, e. g. , in the range of 26 mcd<sup>(15)</sup>.

Dow-18 Treatment. The Dow-18 treatment (Data Sheet 20) is a touch-up treatment as applied by brush or spray, but also can be used as a dip treatment. An ammonia solution containing acid phosphate and sulfite is used. The protection afforded is about the same as the Dow-17 (thin) coating when both are painted with the same finishing system. The coating is medium-to-dark gray. It should be used as a paint base rather than used unpainted. Salt-spray and exterior-exposure tests have shown that this treatment is effective for touching up magnesium-lithium alloys<sup>(12)</sup>.

Ferric Nitrate Bright Pickle (Dow-21). The Dow-21 treatment (Data Sheet 25) has been shown to be satisfactory as a pretreatment for magnesium-lithium alloys which are to be coated with the Dow-17 (thin) treatment or the Dow-18 touch-up treatment<sup>(12, 16)</sup>. No data were found as to the protection afforded by painting with a clear lacquer directly over the surface treated with ferric nitrate.

Irridite-15 Coating. The Irridite-15 conversion coating is intended as a paint base, which can be applied by either brush-on or dip methods. The solution is a chromic acid-sodium nitrate mixture that can be used at room temperature (Data Sheet 21). When used as a touch-up treatment on magnesium-lithium alloys, it was found to be about as effective as Dow-18.

Dow-16 Bright Pickle. The Dow-16 treatment (Data Sheet 24) has been shown to be satisfactory as a pretreatment for magnesium-lithium alloys for the Dow-17 (thin) treatment or Dow-18 touch-up treatment<sup>(12)</sup>. However, no data are available as to the protection that would be afforded by a clear lacquer over Dow-16 alone.

HAE Coating Treatment. The HAE anodic treatment is applied to magnesium-lithium alloys in accordance with Data Sheet 30. This coating is about as effective in reducing corrosion and as a paint base as the Dow-17 process<sup>(17)</sup>. There are several modifications of the HAE process, but no thorough evaluation of these for the magnesium-lithium alloys has been reported.

Fluoride Anodize Treatment. This process is primarily a cleaning treatment. It consists of anodizing in an ammonium bifluoride-water solution. The usual solution is 10 per cent by weight  $\text{NH}_4\text{HF}_2$ , but IBM has found that for the LA141 and LA91 alloys a 30 per cent by weight solution is better (Data Sheet 27). Cleaning of parts before treatment is recommended, which consists of brushing to remove loose dirt or sand, followed by cleaning with a caustic potash solution (Data Sheet 26)<sup>(18)</sup>.

Alternating current is used at a current density of about 5 amp/square foot with up to 120 volts. As with most a-c anodizing, the areas of the two electrodes (both work-pieces) must be equal. Also, all parts below the solution level must be magnesium alloys, and the work must be at least 9 inches below the surface.

During cleaning by this process, a fluoride film built up on the surface acts as a paint base. IBM uses this as a base for its epoxy paint system, which is an adaptation of the Aroldite 985E painting method<sup>(19)</sup>.

### Evaluation of Conversion Coatings for Paint-Base Treatments

Table A-8 shows a number of standard and experimental conversion coatings compared in the painted condition. The Dow-17 (60-volt) coating was clearly superior to the others, with the 8 per cent  $H_3PO_4$  dip treatment as second best. It was further shown that brushing on the 8 per cent  $H_3PO_4$  was better than the dip treatment. The chromate-type treatments were not satisfactory. Experimental evidence indicates that chromate conversion coatings are attacked by the alkaline lithium-hydroxide corrosion product<sup>(7)</sup>. A comparison of Dow-17 and the stannate coating was given under the stannate coating selection.

### Primers, Inhibitors, and Paint Systems

It has been shown that the organotin compounds such as tributyltin oxide are excellent inhibiting pigments for magnesium alloy applications, including magnesium-lithium alloys<sup>(15)</sup>. Additions of powdered tin as inhibitors also are effective. In fact a combination of the organotin compound with metallic tin is more effective than either inhibitor alone. It was also shown that tin-plated steel is more compatible with magnesium alloys than cadmium- or zinc-plated steel in galvanic couplings<sup>(15)</sup>.

In one experimental program, the best formulation was based on Unichrome AP10 (Metals and Thermite Co.) to which 10 per cent tributyltin oxide plus 3 oz/gal of tin dust were added. This formulation is applied over either Dow-17 or HAE conversion coatings. In galvanic couples it is recommended that both metals be painted, then assembled, and then repainted. After this primer coating, appropriate top coats may be added<sup>(15)</sup>.

Another coating system found satisfactory on the LA142 alloy when used over the 60-volt Dow-17 coating is as follows:

- Step 1. 60-volt Dow-17
- Step 2. 1-coat (Mil-C-15328) wash primer (with 20 per cent of the  $H_3PO_4$  replaced by isopropanol)
- Step 3. 3-coat Truscon Chemfast Epoxy Enamel (total paint thickness approximately 0.003 inch).

TABLE A-8. EVALUATION OF PAINT-BASE SYSTEMS FOR ALLOY LA142

System Evaluated, for Indicated Paint and Test Method	
	AP10 Zinc Chromate Primer Baked 10 Min at 300 F plus TTE 485 Topcoat, 1.0 Mil Total Thickness Weatherometer, 181 Hrs of Light, 91 Hrs of Rain
	AP10 Zinc Chromate Primer Baked 10 Min at 300 F, 0.5-Mil Total Thickness 3 Months, Outdoor Exposure
Evaluation	
Excellent	Dow 17 (60 volts) Dow 17 (60 volts)
Good	Dow-7 (with activator pickle predip) 8 per cent H <sub>3</sub> PO <sub>4</sub> Dow-7 (with activator pickle predip) 8 per cent H <sub>3</sub> PO <sub>4</sub> Dow-7 (with HF predip) Dow-18 (dip) 15 per cent NaAlO <sub>2</sub> Dow-7 15 per cent NaAlO <sub>2</sub> + 25g/l Na <sub>2</sub> Cr <sub>2</sub> O <sub>7</sub> · 2H <sub>2</sub> O Dow-7 Dow-7 (with HF predip) 15 per cent NaAlO <sub>2</sub> Dow-1 10 per cent NH <sub>4</sub> HF <sub>2</sub> 10 per cent NH <sub>4</sub> HF <sub>2</sub> (a)
Fair	Ferric nitrate pickle Dow-18 (dip) 15 per cent NaAlO <sub>2</sub> + 25g/l Na <sub>2</sub> Cr <sub>2</sub> O <sub>7</sub> · 2H <sub>2</sub> O Dow-7 Dow-7 (with HF predip) 15 per cent NaAlO <sub>2</sub> + 25g/l Na <sub>2</sub> Cr <sub>2</sub> O <sub>7</sub> · 2H <sub>2</sub> O Dow-1 10 per cent NH <sub>4</sub> HF <sub>2</sub> + 100g/l Na <sub>2</sub> Cr <sub>2</sub> O <sub>7</sub> · 2H <sub>2</sub> O None
Poor	Dow-7 (with HF predip) 15 per cent NaAlO <sub>2</sub> Dow-1 10 per cent NH <sub>4</sub> HF <sub>2</sub> 10 per cent NH <sub>4</sub> HF <sub>2</sub> (a)
No good	Dow-18 10 per cent NH <sub>4</sub> HF <sub>2</sub> + 100g/l Na <sub>2</sub> Cr <sub>2</sub> O <sub>7</sub> · 2H <sub>2</sub> O 15 per cent NaAlO <sub>2</sub> Ferric nitrate pickle

(a) Simple immersion treatment, not fluoride anodize.

The following specifications cover vinyl coatings which have been shown to be effective on magnesium-lithium alloys<sup>(17)</sup>:

- (1) Wash primer (Mil-P-15936), clear or gray vinyl coatings (Navy)
- (2) Mil-E-13515 covers all colors and olive drab (Air Force)
- (3) Mil-L-14486 (Ordnance).

The following specifications cover epoxy and wash primer systems which have been shown to be effective on magnesium-lithium alloys<sup>(17)</sup>:

- (1) Mil-C-15328
- (2) Mil-P-27316.

Table A-9 shows the adaptation of the British Aroldite 985E painting process which is being used by Munroe of IBM on magnesium-lithium alloys<sup>(18,19)</sup>. The Hysol 4225 resin and Hysol 5126 solvent (Hysol Corporation) are specified, but other similar epoxy formulations would probably work equally well. A unique step in this coating process is the heating of the metal to about 400 F prior to painting (Table A-9, Step 4). This is said to "delithiumize" the metal surface and thus promote better adherence. Also, the paint formulation is applied to the surface while it is still above room temperature and still dry. The fluoride anodic treatment is used by IBM for magnesium-lithium alloys<sup>(18)</sup>.

It should be pointed out that the compatibility of any type of paint, especially the primer coat, on magnesium is greatly affected by the alkaline condition of the metal surface at breaks in the paint coating. With magnesium-lithium alloys, this factor is even more important than with most other magnesium alloys because of the very high alkalinity of the natural corrosion product<sup>(17)</sup>.

Baking temperatures and times for curing paint coatings must be considered as annealing treatments of the metal too, because the temperatures are in the same range. For this reason, the combination of annealing and curing times and temperatures must be correlated to produce the properties needed in both paint and metal.

#### Metallic Coatings for Commercial Magnesium Alloys

There are three accepted methods of applying metallic coatings to commercial magnesium alloys. These are (1) immersion zinc plating, (2) electroless (immersion) nickel plating, and (3) direct electroplating of nickel. The first two are found to be far more effective than the third. In each case other metals which can be electroplated, can be deposited by standard methods over the initial layer of zinc or nickel.

Electroless Nickel. Electroless nickel is deposited on magnesium surfaces by continuous chemical reduction without applied current<sup>(20)</sup>. The solution from which the nickel is deposited contains nickel acid fluoride, sodium hypophosphite, and a pH buffering or complexing compound (Data Sheet 9). This method of plating is said to be satisfactory for magnesium-lithium alloys<sup>(17)</sup>, but no published data are available.

TABLE A-9. IBM METHOD OF APPLYING EPOXY-BASE RESINS TO MAGNESIUM-LITHIUM ALLOYS(18, 19)

Step	Method	Bath Composition	Operating Conditions
(1) Cleaning	Mechanical	Brush off sand	
(2) Cleaning	Vapor degreasing	Any of the usual solvents	
(3) Cleaning	Alkaline	KOH ----- 6-8 oz/gal Na <sub>3</sub> PO <sub>4</sub> ----- 1.33 oz/gal Wetting agent -- 0.067 oz/gal Water ----- to make 1 gal Circulating air Running water NH <sub>4</sub> HF <sub>2</sub> --- 30 weight per cent	180-200 F, 5 <sup>+1</sup> <sub>-0</sub> min
(4) Delithiumizing	Heating		410 to 437 F, 1 hr
(5) Rinsing			104 F, 5 min
(6) Surface treatment	Fluoride anodize		<86 F Voltage increased to 120 volts for 5 min after the current density falls below 5 amp/sq ft. 302 ±18 F; heated until surface reaches temp
(7) Drying	Heating	Circulating air	No contact with oven walls Cool to 131 F
(8) Cooling		Air	
(9) Coating	Dip coating	Hysol 4225 - 50 weight per cent Hysol 5126 - 50 weight per cent	
	Spray coating	Hysol 4225 - 35 weight per cent Hysol 5126 - 45 weight per cent	
(10) Curing	Air drying	Clean air	Room temperature, 30 ±5 min
(11) Recoating		Repeat Steps 7, 8, 9, and 10	Total thickness 1.5 to 2.0 mills
(12) Final Cure	Baking	Electric furnace, circulating air	365 ±9 F, 1 hr ±5 min Good coating will be medium-amber color

The electroless nickel coating is resistant to continuous heating at 700 F and to thermal shock if it is stress relieved for 2 hours at 350 F. The fatigue strength of commercial magnesium is said to be improved by as much as 60 per cent by the nickel coating<sup>(20)</sup>.

Electroless nickel can be applied directly to magnesium alloy surfaces by using the chemical-etch method of pretreatment. This method involves etching by an aqueous bath containing chromic acid or bichromate and nitric acid. A very fine etch is produced with undercut pits which provide an excellent base for adherent metal coatings. Since the magnesium surfaces are etched, the final nickel surface will not be so smooth as with the zinc-immersion method. Because of the severe action of this chemical etch, usually no other pickling is necessary to clean up the surface before etching.

The etching is a two-step process. After the chromic acid dip and water rinse, the work is dipped into an aqueous hydrofluoric acid solution. This HF dip removes all trace of chromate and replaces the chromate film with a fluoride film.

The operating conditions of the chemical etch are given in Data Sheet 8. Longer treatment times produce better adhesion, but the surface roughness is also increased.

Immediately after rinsing, the work is transferred to the nickel-plating bath (Data Sheet 9). After the nickel has been applied to the magnesium alloy surface, the coating should be annealed for 2 hours at 350 F, particularly if the coating is to be subsequently exposed to high temperatures, such as in soldering. Finally, the corrosion resistance of the coating can be improved by a passivating treatment (Data Sheet 8) in a chromate solution. This treatment should be done after soldering, adhesive bonding, or other such operations.

Immersion Zinc Plating. As with all other plating and coating techniques, immersion plating requires prior surface preparation. The metal surface must be free of such contaminants as oxide layers, lubricants, and graphite. If a very smooth surface is required, mechanical polishing of the base metal is necessary. Blasted surfaces are highly reactive and must be pickled before plating. The preferred methods of surface preparation vary with wrought and cast products<sup>(20)</sup>.

A number of different acid solutions can be used for pickling. These are given in Data Sheets 11 to 14. Treatments 11 and 12 can be used on all alloys and all forms. Treatment 13 can be used only on wrought forms. Treatment 14 causes no dimensional change, so is best for high-tolerance items.

Just prior to zinc-immersion coating it is necessary to activate the metal surface. Several solutions will act as the activating pickle, e. g., dilute hydrochloric acid (0.5 to 1 per cent) or a 20 per cent solution of aluminum chloride; the one most commonly used is a phosphate-fluoride solution given in Data Sheet 15.

Another method of surface preparation combines alkaline cleaning and activation. This method cannot be used if the metal surface has been chromated for storage protection. If normal oxide films and only a slight amount of oily substances are present, the method given in Data Sheet 16 is satisfactory.

After the activation treatment, the work is rinsed and immediately transferred to the zinc-immersion coating bath (Data Sheet 17).

After the zinc coating is deposited, the work is rinsed and immediately transferred to the copper cyanide bath for copper electroplating (Data Sheet 18). After the copper strike, other metals may be electrodeposited as required.

Though it is reported that the immersion zinc coating will work on all magnesium alloys, no data have been found specifically for the magnesium-lithium alloys.

Direct Nickel Electroplating. Nickel can be electroplated directly onto magnesium alloys from a nickel acid fluoride solution. This plating method can also be used over the zinc-immersion-plus-copper-strike coating to assure nickel coverage in deeply recessed areas. If the zinc-immersion method of preparation is not used, the chemical etch pretreatment (Data Sheet 8) must be used.

A nickel coating is electrodeposited from the bath described in Data Sheet 19. The nickel coatings are semibright and relatively smooth. A thin strike of this nickel plate, approximately 0.0001 to 0.0003 inch thick, is applied. Bright nickel can be used, or other electroplates can be applied, or the nickel coating can be applied from the same bath in thicker layers for wear resistance.

The quality of the nickel coating electrodeposited directly onto the magnesium metal is not so good as that produced over the zinc-immersion coating or by the electrodeless nickel method. It has not been demonstrated that this method is applicable to magnesium-lithium alloys.

Gas Plating of Aluminum on Magnesium. A French patent (No. 1,213,186) describes a process for applying aluminum to magnesium alloy by gas plating. The details of this process were not available.

Recommended Program to Fill Voids in Corrosion  
Behavior and Corrosion-Protection Data

Additional research is needed to establish conclusively the effects of lithium level, aluminum level, and manganese content in the LA141 type of alloy. More corrosion data on the detrimental effects of sodium and iron are also needed. Further corrosion research will be required for the higher-strength magnesium-lithium alloys as these become of interest to industry and government agencies. In the corrosion study, compositional effects relating to the production and use of this type alloy need to be remembered.

Much more information is needed on effective methods of protecting magnesium-lithium alloys. There are a great number of surface treatments that have been applied successfully to other magnesium alloys. Although some of these processes have already been tried on magnesium-lithium alloys, there are other good coatings which are easier to apply or have other special advantages. If these coating processes could be successfully adapted to the magnesium-lithium alloys, wider use of these new alloys in defense applications would be expected.

A comparison of the corrosion protection afforded by newly developed coatings also would be needed. The initial screening could be by suitable laboratory accelerated tests, such as a 100 per cent humidity environment. Outdoor-exposure tests also would be needed to fully establish the extent of the protection afforded. It is suggested that treated panels be exposed under two outdoor conditions and under two indoor conditions.

- (1) Exposure to semi-industrial atmosphere
- (2) Exposure to marine atmosphere (sea shore)
- (3) Indoor exposure in unheated warehouse
- (4) Exposure in a 100 per cent humidity cabinet.

These exposures would be of sufficient variety to show the relative value of each of the candidate surface treatments.

Since an alkaline-resistant organic coating is the usual means of augmenting the corrosion protection of surface conversion coatings, it is believed that several suitable types of paint systems should be evaluated over each of the candidate surface treatments. Research is also needed to adapt methods for electroplating metallic coatings on commercial magnesium to the magnesium-lithium alloys.

References

- (1) Grube, G. , et al. , Z. Elektrochem. , Vol 40, p 160 (1934).
- (2) Stephan, E. F. , "Corrosion Evaluation of Mg-Li Alloys", Internal Memorandum, Battelle Memorial Institute, Research under ABMA Contract DA-33-019-ORD-2593.
- (3) Hume-Rothery, W. , Raynor, G. V. , and Butchers, E. , "Equilibrium Relations and Some Properties of Mg-Li and Mg-Ag-Li Alloys", J. Inst. Metals, Vol 71, pp 589-601 (1945).
- (4) Jackson, J. H. , Frost, P. D. , Loonam, A. C. , Eastwood, L. W. , and Lorig, C. H. , "Mg-Li Base Alloys — Preparation, Fabrication, and General Characteristics", J. Metals, Vol 1, No. 2; Trans. AIME, pp 149-168 (1949).
- (5) Frost, P. D. , et al. , "Development of Mg-Li Base Alloys", Report to Bureau of Aeronautics, Contract NOas 9526, Battelle Memorial Institute (May, 1950).
- (6) Berry, J. T. , Murphy, A. H. , and Gouwens, P. R. , "Magnesium-Lithium Alloys for Armored Vehicle Applications", Final Report, ARF 2190-15, Armour Research Foundation (April 3, 1961).
- (7) Hoornstra, C. W. , "Finishing System for LA142 Alloy", Dow Metal Products Company, Final Report, MT 18035 Contract No. DA-20-018-ORD-15739.
- (8) Bothwell, M. R. , "Corrosion of LA142 Alloys", Dow Metal Products Company Report No. 18184, Final Report, File 171 (October 19, 1959).
- (9) Payne, R. M. , and Eynon, J. D. L. , "Note on the Influence of Sodium on Magnesium-Lithium Alloys", Journal of the Institute of Metals, Vol 86, pp 351-52 (1957-58).
- (10) Willner, E. , "LA141XA, A Magnesium Alloy for Aerospace Vehicles", Lockheed Missiles and Space Company, Report LMSC-A062113, paper presented at the Annual Magnesium Association Conference (October, 1962).
- (11) Frost, P. D. , Fink, F. W. , Pray, H. A. , and Jackson, J. H. , "Results of Some Marine Atmosphere Tests on Mg-Li Alloys", J. Electrochem. Soc. , Vol 102, No. 5, pp 215-218 (May, 1955).
- (12) "Touch-Up Paint Base Treatment for Mg-Li Alloys", Dow Metal Products Company, Report No. CSR-279 (June 15, 1962).
- (13) Anon. , "Stannate Immersion Treatment — Tentative Processing Bulletin", Dow Metal Products Company, Midland, Michigan, Contract DA-20-018-ORD-19650.
- (14) Anon. , "Protective Coatings on Magnesium Alloys Intended for Use on Components of Airborne Vehicles", Dow Metal Products Company, Final Report, Modification No. 1, Supplemental Agreement, Contract No. DA-20-ORD-19650 (June 1, 1960).

- (15) Glesner, C. W. , and DeLong, H. K. , "Protective Coatings on Magnesium Alloys Intended for Use on Components of Airborne Vehicles", Dow Metal Products Company, Final Report, Contract No. DA-20-018-ORD-19650 (July 1, 1960).
- (16) No Author, "Chemical Treatment No. 21, Ferric Nitrate Bright Pickle for Magnesium", Data Sheet 147-12-750-1160, Dow Metal Products Company (undated).
- (17) DeLong, H. K. , Dow Metal Products Company, private communication to F. W. Fink (October 11, 1962).
- (18) Munroe, R. A. , "Application Requirements for Fluoride Anodizing", IBM Engineering Specification No. 6009416, International Business Machines Corporation, Federal Systems Division (June 22, 1962).
- (19) Munroe, R. A. , "Application Requirements for Coating Epoxy-Based Coating Material", IBM Engineering Specification No. 6009415, International Business Machines Corporation, Federal Systems Division (June 22, 1962).
- (20) DeLong, H. K. , "Plating on Magnesium by Electrodeposition and Chemical Reduction Methods", reprint from 48th Annual Technical Proceedings of the American Proceedings of the American Electroplaters' Society, Inc. , Dow Metal Products Company (1961).

APPENDIX B

DATA SHEETS ON SURFACE TREATMENTS  
AND COATINGS FOR COMMERCIAL MAGNESIUM ALLOYS\*

---

\*Data-sheet information made available by Defense Metals Information Center.

DATA SHEET 1Type of Treatment or Coating: Conversion coatingProcess Names: Stannate coatingUses: For paint base

For corrosion protection

For galvanic protection (produces a tin coating on iron and other metal inserts.

Note: The bath attacks aluminum.

Type of Bath: ImmersionBath Composition:

Sodium hydroxide	1-1/3 oz
Potassium stannate ( $K_2SnO_3 \cdot 3H_2O$ )	6-2/3 oz
Sodium acetate ( $NaC_2H_3O_2 \cdot 3H_2O$ )	1-1/3 oz
Tetrasodium pyrophosphate ( $Na_4P_2O_7$ )	6-2/3 oz
Water	To make 1 gal
Sodium hydrophosphate ( $Na_2S_2O_4 \cdot 2H_2O$ ) may be added if chromates are present.	

Operating Conditions:

Temperature 170-190 F (180 F)  
 Time 20-45 min  
 (The bath is heated to 140-150 F before  
 the  $Na_4P_2O_7$  is added. Air or  
 mechanical agitation may be  
 used.)

Thickness of Coating: 0.00015-inch minimum (on AZ31B-O, 20 min = 0.0002 inch)Tank Material: Mild steel; also, heating coils of mild steelPretreatments: Degreasing, solvent or vapor; alkaline cleaning; HF pickle or  $HNO_3$ Posttreatments: Water rinse; if painted use sodium acid fluoride dipRemarks: All residual chromic acid must be removed. HF pickle is very good with steel inserts and chromate coatings from Mg alloy.

DATA SHEET 2

Type of Treatment or Coating: Posttreatment for conversion coating

Process Names: Sodium acid fluoride dip

Uses: To neutralize stannate coating before painting

Type of Bath: Immersion

Bath Composition:

Sodium acid fluoride ( $\text{NaHF}_2$ )	50 g/l or 6-2/3 oz/gal
Water	To make 1 liter or 1 gal

Operating Conditions:

Temperature	Room
Time	30 sec (2 min maximum)
(The solution can be sprayed or brushed with a contact time of 30 sec)	

Pretreatments: Stannate coating plus water rinse

Posttreatments: Cold running-water rinse; hot-water rinse can be used to aid drying

Remarks: Use a grade of  $\text{NaHF}_2$  with less than 0.5 per cent total impurities. If dipping by sections is necessary, carry out the whole process on one section then repeat with overlapping, and rinse well.

DATA SHEET 3

Type of Treatment or Coating: Pickling treatment

Process Names: Nitric acid pickle

Uses: For use when surface contamination cannot be removed by HF pickle

Type of Bath: Immersion

Bath Composition:

HNO <sub>3</sub> (70%)	6.4 fl oz/gal
Water	To make 1 gal

Operating Conditions:

Temperature	Room
Time	1 to 2 min

Dimensional Change: High

Tank Material: Ceramic, rubber, aluminum

Pretreatments: Degrease

Posttreatments: Rinse in cold, running water

Remarks: Solution can be used with spray or brush

DATA SHEET 4

Type of Treatment or Coating: Cleaning

Process Names: Chromic acid cleaner

Uses: For removing oxide coatings not removed by HF pickle  
For use when dimensional change cannot be tolerated

Type of Bath: Immersion

Bath Composition:

CrO <sub>3</sub>	24 oz/gal
Water	To make 1 gal

Operating Conditions:

Temperature	Room to 190 F
Time	15 min

Tank Material: Lead, stainless steel, 1100 aluminum

Pretreatments: Degreasing

Posttreatments: Alkaline clean + HF pickle

DATA SHEET 5

Type of Treatment or Coating: Pickling treatment

Process Names: Hydrofluoric acid pickle

Uses: For cleaning and activating Mg surfaces  
(Also cleans and conditions the surface of steel inserts)  
For removing previously applied chromate coatings

Type of Bath: Immersion

Bath Composition:

HF (as 100% HF)	19-25.5 fl oz/gal
Water	To make 1 gal
(Minimum HF content 10 vol per cent)	

Operating Conditions:

Temperature	Room
Time	5 min

Tank Material: Lead, rubber, synthetic rubber

Pretreatments: Degreasing

Posttreatments: Thorough rinsing in cold water

DATA SHEET 6

Type of Treatment or Coating: Cleaning treatment

Process Names: Heavy-duty alkaline cleaner

Uses: For cleaning off oil and grease, especially if the surface was once treated with chrome pickle or by dichromate treatments

Type of Bath: Immersion

Bath Composition:

NaOH	8 oz/gal
Na <sub>3</sub> PO <sub>4</sub> ·10H <sub>2</sub> O	1-1/3 oz/gal
Wetting agent	0.067 oz/gal
Water	To make 1 gal

Operating Conditions:

Temperature	180 to 212 F
Time	3 to 15 min

Thickness of Coating: None

Dimensional Change: None

Tank Material: Steel

DATA SHEET 7

Type of Treatment or Coating: Cleaning Treatment

Process Names: Deoxidizer, alkaline cleaner

Uses: For removing oil and grease when the metal surfaces are only slightly contaminated

Type of Bath: Immersion

Bath Composition:

$\text{Na}_4\text{P}_2\text{O}_7$	5-1/3 oz/gal
$\text{Na}_2\text{B}_4\text{O}_7 \cdot 10\text{H}_2\text{O}$ (Borax)	9-1/3 oz/gal
NaF	2 oz/gal
Water	To make 1 gal

Operating Conditions:

Temperature	170 to 180 F
Time	2 to 5 min

Tank Material: Steel

DATA SHEET 8Type of Treatment or Coating: Cleaning and activating pickleProcess Names: Chemical etch treatmentUses: Pretreatment for electroless nickel platingType of Bath: ImmersionBath Composition:

<u>Step I</u>		<u>Step II</u>	
CrO	120 g/l	HF (70%)	220 ml/l
HNO <sub>3</sub> (70%)	110 ml/l	Water	To make 1 liter
Water	To make 1 liter	or	
	or	HF (70%)	54 ml/l
CrO	60 g/l	Water	To make 1 liter
HNO <sub>3</sub> (70%)	90 ml/l		
Water	To make 1 liter		

Operating Conditions:

	<u>Step I</u>	<u>Step II</u>
Temperature	Room	Room
Time	20 sec to 2 min	10 min

Pretreatments: DegreasingPosttreatments: Electroless nickel platingRemarks: The stronger solutions above are for Mg alloys containing aluminum.  
The other solution is for other alloys.

DATA SHEET 9Type of Treatment or Coating: Metallic coatingProcess Names: Electroless nickelUses: For plating nickel on magnesium alloys  
For plating aluminum, steel, copper, or brassProtective Value:

Abrasion Resistance: 350-400 VPN to 640 VPN by heat treatment

Type of Bath: ImmersionBath Composition:

2 NiCO <sub>3</sub> · 3Ni(OH) <sub>2</sub> · 4H <sub>2</sub> O	10 g/l
HF (70%)	6 ml/l
Citric acid (C <sub>6</sub> H <sub>8</sub> O <sub>7</sub> )	5.5 g/l
NH <sub>4</sub> HF <sub>2</sub>	15 g/l
NaH <sub>2</sub> PO <sub>2</sub> · H <sub>2</sub> O	20 g/l
NH <sub>4</sub> OH (30%)	30 ml/l
Water	To make 1 liter

Operating Conditions:

Temperature	170-180 F
pH	4.5-6.8 (6.5)
Agitation	Agitate work

Thickness of Coating: 0.0008 in. /hrTank Material: Polyethylene, Lucite, Saran (tank should be heated by hot water or hot air)Posttreatments: Stress relieve at 350 F for 2 hrRemarks: pH adjusted with NH<sub>4</sub>OH. Add the nickel carbonate to the HF then add about 100 ml water to form NiHF<sub>2</sub>, then add water and other chemicals. Filter final solution.

DATA SHEET 10

Type of Treatment or Coating: Passivation treatment

Process Names: Nickel passivation treatment

Uses: For improving the corrosion resistance of the electroless nickel coating.

Type of Bath: Immersion

Bath Composition:

CrO <sub>3</sub>	2.5 g/l
Water	To make 1 liter

or

Na <sub>2</sub> Cr <sub>2</sub> O <sub>7</sub> ·2H <sub>2</sub> O	120 g/l
Water	To make 1 liter

Operating Conditions:

Temperature	190-212 F
Time	10 min

Remarks: This treatment is not used when material is to be further plated or soldered.

DATA SHEET 11

Type of Treatment or Coating: Pickling treatment

Uses: For pretreatment for coatings

Type of Bath: Immersion

Bath Composition:

CrO <sub>3</sub>	180 g/l
Fe(NO <sub>3</sub> ) <sub>3</sub> · 9H <sub>2</sub> O	40 g/l
KF	3.5-7 g/l
Water	To make 1 liter

Operating Conditions:

Temperature	Room
Time	1/4 to 2 min

Remarks: Low fluoride for wrought products, high fluoride for cast products.

DATA SHEET 12

Type of Treatment or Coating: Pickling treatment

Uses: For a cleanup and pretreatment for coatings

Type of Bath: Immersion

Bath Composition:

H<sub>3</sub>PO<sub>4</sub> (85%)

Operating Conditions:

Temperature  
Time

Room  
5 min

DATA SHEET 13

Type of Treatment or Coating: Pickling treatment

Uses: For a pretreatment for coatings

Type of Bath: Immersion

Bath Composition:

Acetic acid (100%)	280 g/l
NaNO <sub>3</sub>	80 g/l
Water	To make 1 liter

Operating Conditions:

Temperature	Room
Time	1/2 to 2 min

DATA SHEET 14

Type of Treatment or Coating: Pickling Treatment

Uses: For a pretreatment for coatings

Type of Bath: Immersion

Bath Composition:

CrO<sub>3</sub>                    180 g/l  
Water To make 1 liter

Operating Conditions:

Temperature            Room to boiling  
Time                      2 to 10 min

B-15

DATA SHEET 15

Type of Treatment or Coating: Activating pickle

Process Names: Phosphoric acid - ammonium acid fluoride pickle

Uses: Activator treatment for zinc immersion coating

Type of Bath: Immersion

Bath Composition:

H <sub>3</sub> PO <sub>4</sub> (85%)	200 ml/l
NH <sub>4</sub> HF <sub>2</sub>	100 g/l
Water	To make 1 liter

Operating Conditions:

Temperature	Room
Time	1/4 to 2 min

DATA SHEET 16

Type of Treatment or Coating: Cleaning and pickling

Uses: Used only if no chromate coating is present and if only a small amount of oily matter is present. Activation treatment for zinc immersion coating

Type of Bath: Immersion

Bath Composition:

$\text{Na}_4\text{P}_2\text{O}_7$	40 g/l
$\text{Na}_2\text{B}_4\text{O}_7 \cdot 10\text{H}_2\text{O}$	70 g/l
NaF	20 g/l
Water	To make 1 liter

Operating Conditions:

Temperature	170 F
Time	2 to 5 min

DATA SHEET 17Type of Treatment or Coating: Metallic coatingProcess Names: Immersion zinc platingUses: Initial deposit over which other metals may be electroplated.Type of Bath: ImmersionBath Composition:

		<u>Alternate Bath</u>	
ZnSO <sub>4</sub> ·H <sub>2</sub> O	30 g/l	ZnSO <sub>4</sub> ·H <sub>2</sub> O	45 g/l
Na <sub>4</sub> P <sub>2</sub> O <sub>7</sub>	120 g/l	Na <sub>4</sub> P <sub>2</sub> O <sub>7</sub>	210 g/l
KF	7 g/l	KF	7 g/l
Na <sub>2</sub> CO <sub>3</sub>	5 g/l	Na <sub>2</sub> CO <sub>3</sub>	5 g/l
Water	To make 1 liter	Water	To make 1 liter

Operating Conditions:

Temperature 175-180 F  
 Time 1 to 10 min  
 pH 10 to 10.6 (with Na<sub>2</sub>CO<sub>3</sub>),  
 best range 10.2 to 10.4  
 (pH can be adjusted  
 down with H<sub>2</sub>SO<sub>4</sub>)

(The ratio of pyrophosphate to zinc should be kept constant.)

Tank Material: Stainless steelPosttreatments: Rinsing and transfer to copper cyanide bath.Remarks: Water for bath should be reasonably free of iron and other heavy metals.

DATA SHEET 18

Type of Treatment or Coating: Metallic coating

Process Names: Copper strike

Uses: For the copper strike over the zinc immersion coating

Type of Bath: Cathodic

Bath Composition:

CuCN	41.25 g/l
KCN	67.5 g/l
KF	30 g/l
Free cyanide	7.5 g/l
Water	

Operating Conditions:

Temperature	130 to 140 F
Time	6 min (minimum)
pH	6-10.4
Current Density	5 to 20 amp/sq ft
Cathode Agitation	8-12 ft/min

Posttreatments: Bright copper or other plating.

Remarks: Lower current density is necessary for the first 2 minutes.

DATA SHEET 19

Type of Treatment or Coating:

Process Names: Nickel plating magnesium

Uses: For plating directly on magnesium alloys

Type of Bath: Electroplating

Bath Composition:

HF (70%)	61.5 ml/l
2 NiCO <sub>3</sub> · 3Ni(OH) <sub>2</sub> · 4H <sub>2</sub> O	120 g/l
Citric acid (C <sub>6</sub> H <sub>8</sub> O <sub>7</sub> )	40 g/l
Sodium lauryl sulfate	1.0 g/l
Water	To make 1 liter

Operating Conditions:

Temperature	120 to 140 F
pH	3.0 (1.0 to 3.0)
Current Density	30 to 100 amp/sq ft
Cathode Agitation	12-16 ft/min

Appearance of Coating: Semibright metallic

Thickness of Coating: 0.0001 to 0.0003 inch

Posttreatments: Chemical etch

DATA SHEET 20

Type of Treatment or Coating: Conversion coating

Process Names: Dow-18

Uses: For touch-up of damaged coating

Protective Value:

Corrosion Resistance: About the same as Dow 17 (thin)

Type of Bath: Immersion, spray, or brush on

Bath Composition:

NH <sub>4</sub> H <sub>2</sub> PO <sub>4</sub>	16 oz
(NH <sub>4</sub> ) <sub>2</sub> SO <sub>3</sub> ·H <sub>2</sub> O	4 oz
NH <sub>4</sub> OH (sp gr 0.880)	2 fl oz
Ethyl alcohol	8-20 fl oz
Water	To make 1 gal

Operating Conditions:

Temperature	Room
Time	Approximately 1 min (if dipped until gassing stops)

Appearance of Coating: Medium to dark gray

Tank Material: Steel, rubber, ceramic, wood

Remarks: Less toxic than brush-on chrome pickle.

DATA SHEET 21

Type of Treatment or Coating: Conversion coating

Process Names: Irridite-15

Uses: For paint base, either as brush-on for touch-up or as dip coating

Type of Bath: Immersion or brush-on

Bath Composition:

CrO <sub>3</sub>	15.75 g/l
NaNO <sub>3</sub>	21.75 g/l
HCl	50 cc/l
Water	To make 1 liter

Operating Conditions:

Temperature	Room
Time	1 min (brush-on)

Posttreatments: Cold-water rinse, short hot-water rinse

DATA SHEET 22Type of Treatment or Coating: Pickle treatmentProcess Names: Phosphoric acid with neutralizationUses: For picklingType of Bath: ImmersionBath Composition:Step I $H_3PO_4$  (85%)Step II

$NH_4HF_2$	20 wt per cent
Water	Bal

Operating Conditions:

	<u>Step I</u>	<u>Step II</u>
Temperature	Room	Room
Time	1 min	Short dip

Appearance of Coating: ClearPosttreatments: Cold-water rinse, hot-water rinse, conversion coating

DATA SHEET 23Type of Treatment or Coating: Conversion coatingProcess Names: Dow-17 (thin coating)

Uses: For corrosion protection                      For decoration  
           For paint base                                      For abrasion resistance  
           For reducing galvanic corrosion

Bath Composition:

NH <sub>4</sub> HF <sub>2</sub>	32 oz
Na <sub>2</sub> Cr <sub>2</sub> O <sub>7</sub> · 2H <sub>2</sub> O	13.3 oz
H <sub>3</sub> PO <sub>4</sub>	11.5 fl oz
Water	To make 1 gal

Operating Conditions:

Temperature	160 to 180 F	
Time	2.5 to 41 min	75 v, 2-1/2 min - AZ31B, AZ61A, M1A, 2K60A 65 v, 4 min - AZ80A, AZ63A, AZ91C, AZ92A 75 v, 4 min - EK30A, EK41A, EZ33A
Current Density	Constant, 5 to 50 amp/sq ft	
Voltage	Up to 110 dc	
Time =	$\frac{200-500 \text{ amp-min/ft}^2}{\text{current density, amp/ft}^2}$	

Appearance of Coating: Light gray or greenThickness of Coating: 0.0003 inchDimensional Change: 0.0002 inchForms and Alloys Used on: All alloysTank Material: Steel, synthetic rubber, vinyl plasticRack Material: Magnesium aluminum (base) or other metal (coated); clamps, Mg or AlPretreatments: Alkaline cleanerPosttreatments: Sodium tetrasilicate seal if parts are not paintedRemarks: Suggested current density 20 amp/sq ft. Bath should be stirred each time it is reheated from room temperature. The direct current treatment requires about 30 per cent less time than the alternating-current treatment (Data Sheet 35).

DATA SHEET 24

Type of Treatment or Coating: Conversion coatings

Process Names: Bright pickle (castings)  
Dow-16

Uses: Decorative finish

Type of Bath: Immersion

Bath Composition:

CrO <sub>3</sub>	37.5 oz
HNO <sub>3</sub> (70%)	3.25 oz
HF (60%)	1.0 fl oz
Water	To make 1 gal

Operating Conditions:

Temperature	70 to 90 F
Time	0.5 to 2 min

Appearance of Coating: Silvery

Forms and Alloys Used on: Dowmetal C, H, R and AZ 91C

Tank Material: Rubber, Tygon, Koroseal

DATA SHEET 25Type of Treatment or Coating: Conversion coating and picklingProcess Names: Ferric nitrate bright pickle  
Dow-21Uses: Protection during storage, paint base (clear enamels, to clean surfaces for spot welding, removing graphite lubricants, removing mill scale and corrosion products, general clean-up pickle.Protective Value:

Corrosion Resistance: Prevents tarnishing for 6 months indoors

Type of Bath: Immersion or sprayBath Composition:

<u>Step I</u>		<u>Step II</u>	
CrO <sub>3</sub>	24 oz	Sodium metasilicate	5 wt per cent
Fe (NO <sub>3</sub> ) <sub>3</sub> · 9H <sub>2</sub> O	5-1/3 oz	Water	Bal
KF	0.47 oz	(Use Step II only if part is stained)	
Water	To make 1 gal		

Operating Conditions:

	<u>Step I</u>	<u>Step II</u>
Temperature	60 to 100 F	160 to 180 F
Time	Short dip	1/2 to 1 min

Dimensional Change: 0.0015 inch per surface per minPretreatments: Vapor degreased, alkaline cleanedPosttreatments: Rinse in cold running water, hot water to dryRemarks: This treatment accentuates flow marks, segregation, etc., on cast surfaces.  
The concentration of KF is critical.

DATA SHEET 26

Type of Treatment or Coating: Cleaning

Process Names: Caustic Potash Treatment

Uses: For cleaning magnesium-lithium alloys before fluoride anodizing

Protective Value:

Corrosion Resistance: None

Type of Bath: Immersion

Bath Composition:

KOH	6-8 oz/gal
Na <sub>3</sub> PO <sub>4</sub>	1.33 oz/gal
Wetting agent (Nacconal NR)	0.067 oz/gal
Water	To make 1 gal

Operating Conditions:

Temperature	180-200 F
Time	5 to 6 min

Pretreatments: Loose sand removed by brushing, vapor degreased

Posttreatments: Rinsed in cold running water

DATA SHEET 27Type of Treatment or Coating: Cleaning and conversion coatingProcess Names: Fluoride anodize (IBM)Uses: For pretreatment for painting  
For cleaning and removing casting sand  
For corrosion resistanceType of Bath: Anodic, acBath Composition:

NH <sub>4</sub> HF <sub>2</sub>	30 ± 5 wt per cent
Water	Bal

Operating Conditions:

Temperature	86 F (max)
Time	30 min
Current Density	Not given (probably about 5 amp/sq ft)
Voltage	Up to 110 to 120 volts
Immersion Depth	At least 9 inches
Equal areas for anode and cathode	

Forms and Alloys Used on: LA141 and LA91Rack Material: All parts below surface of bath must be AZ31BPretreatments: Caustic potash cleaningRemarks: Workpieces must be entirely magnesium with no inserts.

DATA SHEET 28

Type of Treatment or Coating: Conversion coating

Process Names: 8% phosphoric acid treatment

Uses: For coating LA142 alloy  
For paint base  
For coating large pieces which are difficult to treat with Dow-17

Protective Value:

Corrosion Resistance: Nearly as good as Dow-17 on LA142

Type of Bath: Brush on or Immersion

Bath Composition:

H <sub>3</sub> PO <sub>4</sub>	8 wt per cent
Water	Bal

Operating Conditions:

Temperature	Room
Time	15 sec (dip), 1 min (brush-on)
(If dip coating is used, hold in air 20 sec before rinsing)	

Appearance of Coating: Gray

Dimensional Change: 0.5 to 1.0 mil of metal per treatment

Forms and Alloys Used on: LA142

Pretreatments: Degreasing, cleaning

Posttreatments: Painting



---

B-30

(Data Sheet 29 Cont'd)

Posttreatments: Sodium tetrasilicate seal if not painted

Remarks: Bath should be stirred each time it is reheated from room temperature.  
Previous coatings need not be removed. Recommended current density  
20 amp/sq ft.

DATA SHEET 30

Type of Treatment or Coating: Conversion coating

Process Names: HAE process  
Mil-C-13335

Uses: For wear resistance            For high-temperature resistance  
For paint base  
For corrosion resistance

Protective Value:

Corrosion Resistance: Good

Abrasion Resistance: Excellent; harder than steel of Rockwell C65 (Moh  
hardness 7 to 8)

Dielectric Strength: 500 to 600 volts per 1.5 mils' thickness

Type of Bath: Anodic

Bath Composition:

KF	35 g/l
K <sub>2</sub> MnO <sub>4</sub> in water	22 g/l
KOH	120 g/l
Na <sub>3</sub> PO <sub>4</sub>	35 g/l
Al (OH) <sub>3</sub> or Al metal	30 g/l
Water	To make 1 liter

Operating Conditions:

Temperature	Room (below 85 F)
Time	60 to 90 min
Current Density	18 amp/sq ft
Voltage (Terminating)	80 to 85 volts ac
(Initial)	About 40 volts

Appearance of Coating: Dark brown, brittle (light brown - bath needs adjusting)

Thickness of Coating: 0.001 inch thick

Dimensional Change: 0.0008-inch increase

Forms and Alloys Used on: All alloys; preferably thick sections because of the  
brittleness of the coating

Tank Material: Steel, glass, rubber

Rack Material: Mg alloy, masked at liquid-vapor interface

(Data Sheet 30 Cont'd)

Posttreatments: Dichromate-bifluoride sealing treatment

Remarks: Can be applied over chrome pickled surface. Arcing between parts must be prevented. Tanks must be cooled. Units should be assembled before coating is applied.

DATA SHEET 31

Type of Treatment or Coating: Conversion coating

Process Names: Modified HAE

Uses: For paint base

Type of Bath: Anodic

Bath Composition:

KF	35 g/l
K <sub>2</sub> MnO <sub>4</sub> in water	22 g/l
KOH	120 g/l
Na <sub>3</sub> PO <sub>4</sub>	35 g/l
Al (OH) <sub>3</sub> or Al metal	30 g/l
Water	To make 1 liter

Operating Conditions:

Temperature	Below 85 F
Time	6 min
Current Density	18 amp/sq ft

Appearance of Coating: Light tan

Remarks: Coating is controlled by time of 6 min rather than by voltage

DATA SHEET 32Type of Treatment or Coating: Conversion coating, sealing treatmentProcess Names: HAE dichromate-bifluorideUses: For sealing HAE anodized coatingsProtective Value:

Corrosion Resistance: Withstands 200 hours of salt spray

Type of Bath: ImmersionBath Composition:

<u>Step I</u>		<u>Step II</u>
Na <sub>2</sub> Cr <sub>2</sub> O <sub>7</sub>	2 wt per cent	Hold work at 170 F over an open vessel of water for 7 hours
(NH <sub>4</sub> )HF <sub>2</sub>	10 wt per cent	
Water	Bal	

Operating Conditions:

<u>Step I</u>		<u>Step II</u>
Temperature	Room	170 F
Time	45 to 60 sec	7 hr
Drying	Air dry without rinse	

Pretreatments: HAE anodize

DATA SHEET 33

Type of Treatment or Coating: Conversion coating

Process Names: New chrome process

Uses: For wear resistance  
For paint base  
For corrosion resistance

Protective Value:

Corrosion Resistance: Superior to HAE if not sealed  
Abrasion Resistance: Harder than steel

Type of Bath: Anodic

Bath Composition:

KOH	120 g/l
Al	135 g/l
KF	70 g/l
Na <sub>3</sub> PO <sub>4</sub> · 12H <sub>2</sub> O	35 g/l
K <sub>2</sub> CrO <sub>4</sub>	22 g/l
Water	To make 1 l

Operating Conditions:

Temperature	Below 104 F
Time	45 min
Current Density	30 amp/sq ft (electrode)
Voltage	70 to 100 volts ac

Appearance of Coating: Initially, soft yellow green coating.  
After 45 min, smooth green

Thickness of Coating: 0.0015 inch

Pretreatments: Degreased only

Posttreatments: Bifluoride-dichromate

DATA SHEET 34

Type of Treatment or Coating: Conversion Coating

Process Names: Modified Dow-17 coating

Uses: For paint base (clear laquer) to give metallic finish

Protective Value:

Corrosion Resistance: Coating will stand 20 per cent saltspray for 500 hr

Type of Bath: Anodic

Bath Composition:

Same as Dow-17

Operating Conditions:

Temperature	Same as Dow 17
Time	1 min
Voltage	40 volts

Appearance of Coating: Clear

Forms and Alloys Used on: All alloys

DATA SHEET 35Type of Treatment or Coating: Conversion coatingProcess Names: Dow-17 (thin coating)  
Dow anodizeUses: For corrosion protection                      For decoration  
For paint base    For abrasion resistance  
For reducing galvanic corrosionProtective Value:

Abrasion Resistance: Not as good as thick Dow 17

Type of Bath: Anodic acBath Composition:

NH <sub>4</sub> HF <sub>2</sub>	32 oz
Na <sub>2</sub> Cr <sub>2</sub> O <sub>7</sub> · 2H <sub>2</sub> O	13.3 oz
H <sub>3</sub> PO <sub>4</sub> (85%)	11.5 fl oz
Water	To make 1 gal

Operating Conditions:

Temperature	160 to 180 F	
Time	2.5 to 5 min	70 v, 3-1/2 min - AZ31B, AZ61A, M1A, ZK60A, HK31A 60 v, 5 min - AZ80A, AZ63A, AZ91C, AZ92A, LA142 70 v, 5 min - EK30A, EK41A, EZ33A
Current Density	Constant, 20 amp/sq ft	
Voltage	110 v ac	

$$\text{Time} = \frac{200-500 \text{ amp-min/ft}^2}{\text{current density, amp/ft}^2}$$

Appearance of Coating: Light gray or greenThickness of Coating: 0.0003 inchDimensional Change: 0.0002 inchForms and Alloys Used on: All alloysTank Material: Steel, synthetic rubber, vinyl plasticRack Material: Magnesium, aluminum (bare) or other metal (coated); clamps, Mg or Al

(Data Sheet 35 Cont'd)

Pretreatments: Alkaline clean

Posttreatments: Sodium tetrasilicate of coating is not painted

Remarks: The bath should be stirred each time it is reheated from room temperature.  
Previous coatings need not be removed.

DATA SHEET 36

Type of Treatment or Coating: Sealing treatment

Process Names: Water glass sealing treatment

Uses: To seal anodic coatings and improve corrosion resistance; coating cannot be painted.

Protective Value:

Corrosion Resistance: Improves anodic treatment

Type of Bath: Immersion

Bath Composition:

Na<sub>2</sub>Si<sub>4</sub>O<sub>9</sub>                      7 oz  
Water                      To make 1 gal

Operating Conditions:

Temperature                      200 to 212 F  
Time                                      15 min

Pretreatments: Anodic coating

DATA SHEET 37

Type of Treatment or Coating: Conversion coating

Process Names: CR-22 process

Uses: For wear resistance  
For paint adherence

Protective Value:

Corrosion Resistance: Good atmospheric resistance if sealed with silicate  
Abrasion Resistance: Good  
Electrical Resistance: High dielectric strength

Type of Bath: Anodic

Bath Composition:

CrO <sub>3</sub>	25 g/l
HF (50%)	38.5 ml/l
H <sub>3</sub> PO <sub>4</sub> (85%)	50 ml/l
H <sub>4</sub> OH	220 ml/l
Water	To make 1 l

Operating Conditions:

Temperature	167-203 F
Time	20 min
pH	Start 8.0, operation 6.5
Current Density	15 amp/sq ft
Voltage	300 v ac
Amp-Min per Sq Ft	180

Appearance of Coating: Rough green

Thickness of Coating: 0.001 inch

Forms and Alloys Used on: All alloys

Rack Material: Steel

Remarks: Coating can be sealed with sodium silicate. Coating has good heat resistance.

NASA CR-79

Phosphoric acid solutions appear to be suitable reagents in this respect. Limited experiments were conducted on electroplating of copper, nickel, and aluminum on LA141 alloy. Electroplating was found to be feasible for this alloy. Further research will be needed to scale up these experiments for larger surfaces. Brazing experiments revealed that existing brazing filler metals for commercial magnesium alloys are not suitable for magnesium-lithium alloys because of incompatible melting ranges. The development of special brazing filler metals will be required.

NASA

NASA CR-79

Phosphoric acid solutions appear to be suitable reagents in this respect. Limited experiments were conducted on electroplating of copper, nickel, and aluminum on LA141 alloy. Electroplating was found to be feasible for this alloy. Further research will be needed to scale up these experiments for larger surfaces. Brazing experiments revealed that existing brazing filler metals for commercial magnesium alloys are not suitable for magnesium-lithium alloys because of incompatible melting ranges. The development of special brazing filler metals will be required.

NASA

NASA CR-79

Phosphoric acid solutions appear to be suitable reagents in this respect. Limited experiments were conducted on electroplating of copper, nickel, and aluminum on LA141 alloy. Electroplating was found to be feasible for this alloy. Further research will be needed to scale up these experiments for larger surfaces. Brazing experiments revealed that existing brazing filler metals for commercial magnesium alloys are not suitable for magnesium-lithium alloys because of incompatible melting ranges. The development of special brazing filler metals will be required.

NASA

NASA CR-79

Phosphoric acid solutions appear to be suitable reagents in this respect. Limited experiments were conducted on electroplating of copper, nickel, and aluminum on LA141 alloy. Electroplating was found to be feasible for this alloy. Further research will be needed to scale up these experiments for larger surfaces. Brazing experiments revealed that existing brazing filler metals for commercial magnesium alloys are not suitable for magnesium-lithium alloys because of incompatible melting ranges. The development of special brazing filler metals will be required.

NASA

NASA CR-79

National Aeronautics and Space Administration.  
THE DEVELOPMENT OF MAGNESIUM-LITHIUM  
ALLOYS FOR STRUCTURAL APPLICATIONS.  
T. G. Byrer, E. L. White, and P. D. Frost,  
Battelle Memorial Institute. June 1964. 116p.  
OTS price, \$2.50.  
(NASA CONTRACTOR REPORT CR-79)

Exploratory studies were initiated on magnesium-lithium alloys LA141 and LA91. The capability of LA141 to be warm formed into typical aerospace parts requiring simultaneous shrink and stretch operations was demonstrated. Likewise, the ability of the alloy to be extruded through porthole dies into tubular sections having a wall 0.025 inch thick was shown. The LA141 alloy was found to have machinability, in lathe tests, comparable to that of 2024 aluminum alloy at low feed rates but much greater than the aluminum alloy at high feed rates. Both LA141 and LA91 were found to be readily adaptable to metal removal by chemical milling. (over)

NASA

- I. Byrer, T. G.
- II. White, E. L.
- III. Frost, P. D.
- IV. Battelle Memorial Institute
- V. NASA CR-79

NASA CR-79

National Aeronautics and Space Administration.  
THE DEVELOPMENT OF MAGNESIUM-LITHIUM  
ALLOYS FOR STRUCTURAL APPLICATIONS.  
T. G. Byrer, E. L. White, and P. D. Frost,  
Battelle Memorial Institute. June 1964. 116p.  
OTS price, \$2.50.  
(NASA CONTRACTOR REPORT CR-79)

Exploratory studies were initiated on magnesium-lithium alloys LA141 and LA91. The capability of LA141 to be warm formed into typical aerospace parts requiring simultaneous shrink and stretch operations was demonstrated. Likewise, the ability of the alloy to be extruded through porthole dies into tubular sections having a wall 0.025 inch thick was shown. The LA141 alloy was found to have machinability, in lathe tests, comparable to that of 2024 aluminum alloy at low feed rates but much greater than the aluminum alloy at high feed rates. Both LA141 and LA91 were found to be readily adaptable to metal removal by chemical milling. (over)

NASA

- I. Byrer, T. G.
- II. White, E. L.
- III. Frost, P. D.
- IV. Battelle Memorial Institute
- V. NASA CR-79

NASA CR-79

National Aeronautics and Space Administration.  
THE DEVELOPMENT OF MAGNESIUM-LITHIUM  
ALLOYS FOR STRUCTURAL APPLICATIONS.  
T. G. Byrer, E. L. White, and P. D. Frost,  
Battelle Memorial Institute. June 1964. 116p.  
OTS price, \$2.50.  
(NASA CONTRACTOR REPORT CR-79)

Exploratory studies were initiated on magnesium-lithium alloys LA141 and LA91. The capability of LA141 to be warm formed into typical aerospace parts requiring simultaneous shrink and stretch operations was demonstrated. Likewise, the ability of the alloy to be extruded through porthole dies into tubular sections having a wall 0.025 inch thick was shown. The LA141 alloy was found to have machinability, in lathe tests, comparable to that of 2024 aluminum alloy at low feed rates but much greater than the aluminum alloy at high feed rates. Both LA141 and LA91 were found to be readily adaptable to metal removal by chemical milling. (over)

NASA

- I. Byrer, T. G.
- II. White, E. L.
- III. Frost, P. D.
- IV. Battelle Memorial Institute
- V. NASA CR-79

NASA CR-79

National Aeronautics and Space Administration.  
THE DEVELOPMENT OF MAGNESIUM-LITHIUM  
ALLOYS FOR STRUCTURAL APPLICATIONS.  
T. G. Byrer, E. L. White, and P. D. Frost,  
Battelle Memorial Institute. June 1964. 116p.  
OTS price, \$2.50.  
(NASA CONTRACTOR REPORT CR-79)

Exploratory studies were initiated on magnesium-lithium alloys LA141 and LA91. The capability of LA141 to be warm formed into typical aerospace parts requiring simultaneous shrink and stretch operations was demonstrated. Likewise, the ability of the alloy to be extruded through porthole dies into tubular sections having a wall 0.025 inch thick was shown. The LA141 alloy was found to have machinability, in lathe tests, comparable to that of 2024 aluminum alloy at low feed rates but much greater than the aluminum alloy at high feed rates. Both LA141 and LA91 were found to be readily adaptable to metal removal by chemical milling. (over)

NASA

- I. Byrer, T. G.
- II. White, E. L.
- III. Frost, P. D.
- IV. Battelle Memorial Institute
- V. NASA CR-79

NASA CR-79

National Aeronautics and Space Administration.  
THE DEVELOPMENT OF MAGNESIUM-LITHIUM  
ALLOYS FOR STRUCTURAL APPLICATIONS.  
T. G. Byrer, E. L. White, and P. D. Frost,  
Battelle Memorial Institute. June 1964. 116p.  
OTS price, \$2.50.  
(NASA CONTRACTOR REPORT CR-79)

Exploratory studies were initiated on magnesium-lithium alloys LA141 and LA91. The capability of LA141 to be warm formed into typical aerospace parts requiring simultaneous shrink and stretch operations was demonstrated. Likewise, the ability of the alloy to be extruded through porthole dies into tubular sections having a wall 0.025 inch thick was shown. The LA141 alloy was found to have machinability, in lathe tests, comparable to that of 2024 aluminum alloy at low feed rates but much greater than the aluminum alloy at high feed rates. Both LA141 and LA91 were found to be readily adaptable to metal removal by chemical milling. (over)

NASA

- I. Byrer, T. G.
- II. White, E. L.
- III. Frost, P. D.
- IV. Battelle Memorial Institute
- V. NASA CR-79

NASA CR-79

National Aeronautics and Space Administration.  
THE DEVELOPMENT OF MAGNESIUM-LITHIUM  
ALLOYS FOR STRUCTURAL APPLICATIONS.  
T. G. Byrer, E. L. White, and P. D. Frost,  
Battelle Memorial Institute. June 1964. 116p.  
OTS price, \$2.50.  
(NASA CONTRACTOR REPORT CR-79)

Exploratory studies were initiated on magnesium-lithium alloys LA141 and LA91. The capability of LA141 to be warm formed into typical aerospace parts requiring simultaneous shrink and stretch operations was demonstrated. Likewise, the ability of the alloy to be extruded through porthole dies into tubular sections having a wall 0.025 inch thick was shown. The LA141 alloy was found to have machinability, in lathe tests, comparable to that of 2024 aluminum alloy at low feed rates but much greater than the aluminum alloy at high feed rates. Both LA141 and LA91 were found to be readily adaptable to metal removal by chemical milling. (over)

NASA

- I. Byrer, T. G.
- II. White, E. L.
- III. Frost, P. D.
- IV. Battelle Memorial Institute
- V. NASA CR-79