

# NAVAL POSTGRADUATE SCHOOL Monterey, California



## THESIS

**PROJECT OVERVIEW OF THE NAVAL POSTGRADUATE  
SCHOOL SPACECRAFT ARCHITECTURE AND  
TECHNOLOGY DEMONSTRATION EXPERIMENT**

by

Charles R. Reuer

September 2001

Thesis Advisor:  
Thesis Co-advisor:

Rudy Panholzer  
Dan Sakoda

**Approved for public release; distribution is unlimited.**

## Report Documentation Page

<b>Report Date</b> 30 Sep 2001	<b>Report Type</b> N/A	<b>Dates Covered (from... to)</b> -
<b>Title and Subtitle</b> Overview of the Naval Postgraduate School Spacecraft Architecture and Technology Demonstration Experiment	<b>Contract Number</b>	
	<b>Grant Number</b>	
	<b>Program Element Number</b>	
<b>Author(s)</b> Reuer, Charles R.	<b>Project Number</b>	
	<b>Task Number</b>	
	<b>Work Unit Number</b>	
<b>Performing Organization Name(s) and Address(es)</b> Research Office Naval Postgraduate School Monterey, Ca 93943-5138	<b>Performing Organization Report Number</b>	
<b>Sponsoring/Monitoring Agency Name(s) and Address(es)</b>	<b>Sponsor/Monitor's Acronym(s)</b>	
	<b>Sponsor/Monitor's Report Number(s)</b>	
<b>Distribution/Availability Statement</b> Approved for public release, distribution unlimited		
<b>Supplementary Notes</b>		
<b>Abstract</b>		
<b>Subject Terms</b>		
<b>Report Classification</b> unclassified	<b>Classification of this page</b> unclassified	
<b>Classification of Abstract</b> unclassified	<b>Limitation of Abstract</b> UU	
<b>Number of Pages</b> 89		



REPORT DOCUMENTATION PAGE			Form Approved OMB No. 0704-0188	
Public reporting burden for this collection of information is estimated to average 1 hour per response, including the time for reviewing instruction, searching existing data sources, gathering and maintaining the data needed, and completing and reviewing the collection of information. Send comments regarding this burden estimate or any other aspect of this collection of information, including suggestions for reducing this burden, to Washington headquarters Services, Directorate for Information Operations and Reports, 1215 Jefferson Davis Highway, Suite 1204, Arlington, VA 22202-4302, and to the Office of Management and Budget, Paperwork Reduction Project (0704-0188) Washington DC 20503.				
1. AGENCY USE ONLY (Leave blank)		2. REPORT DATE September 2001	3. REPORT TYPE AND DATES COVERED Master's Thesis	
4. TITLE AND SUBTITLE: Project Overview of the Naval Postgraduate School Spacecraft Architecture and Technology Demonstration Experiment			5. FUNDING NUMBERS	
6. AUTHOR(S) Reuer, Charles R.				
7. PERFORMING ORGANIZATION NAME(S) AND ADDRESS(ES) Naval Postgraduate School Monterey, CA 93943-5000			8. PERFORMING ORGANIZATION REPORT NUMBER	
9. SPONSORING / MONITORING AGENCY NAME(S) AND ADDRESS(ES) N/A			10. SPONSORING / MONITORING AGENCY REPORT NUMBER	
11. SUPPLEMENTARY NOTES The views expressed in this thesis are those of the author and do not reflect the official policy or position of the Department of Defense or the U.S. Government.				
12a. DISTRIBUTION / AVAILABILITY STATEMENT Approved for public release; distribution unlimited.			12b. DISTRIBUTION CODE	
<p><b>ABSTRACT (maximum 200 words)</b></p> <p>The Naval Postgraduate School's current attempt at getting another spacecraft into orbit is focusing on Naval Postgraduate School Spacecraft Architecture and Technology Demonstration Experiment (NPSAT1). Building on lessons learned from PANSAT, in addition to targeting incremental improvements and advances in multiple areas of spacecraft design, NPSAT1 is being built as a three-axis stabilized platform. It will be using commercial-off-the-shelf (COTS) components in many of its subsystems to provide some testing and experimentation on how certain COTS components can handle space environments and the challenges this unique environment presents. Other characteristics of NPSAT1 include a PC-compatible Command and Data Handling (C&amp;DH) subsystem, lithium-ion polymer batteries, a Linux operating system, and Ferroelectric RAM.</p> <p>NPS possesses a unique ability to educate a large number of service personnel in a wide variety of space-related topics. In particular, NPS is not only able to provide classroom and laboratory education on principles, concepts, philosophies, and historical perspectives of space, but also it can provide the student the opportunity to conduct on-orbit operations and testing of the same spacecraft that were designed and built on the grounds of the NPS campus. This thesis describes the overall project of designing NPSAT1, and many of the associated requirements that ultimately lead to a successful mission on orbit.</p>				
14. SUBJECT TERMS NPSAT1, Spacecraft Design, Small Satellite, Overview, Space Environment, Lithium-Ion Polymer			15. NUMBER OF PAGES 89	
			16. PRICE CODE	
17. SECURITY CLASSIFICATION OF REPORT Unclassified	18. SECURITY CLASSIFICATION OF THIS PAGE Unclassified	19. SECURITY CLASSIFICATION OF ABSTRACT Unclassified	20. LIMITATION OF ABSTRACT UL	

THIS PAGE INTENTIONALLY LEFT BLANK

Approved for public release; distribution is unlimited

**PROJECT OVERVIEW OF THE NAVAL POSTGRADUATE SCHOOL  
SPACECRAFT ARCHITECTURE AND TECHNOLOGY DEMONSTRATION  
EXPERIMENT**

Charles R. Reuer  
Lieutenant Commander, United States Navy  
B.S., University of Nebraska/Lincoln, 1991

Submitted in partial fulfillment of the  
requirements for the degree of

**MASTER OF SCIENCE IN SPACE SYSTEMS OPERATIONS**

from the

**NAVAL POSTGRADUATE SCHOOL  
September 2001**

Author:

  
\_\_\_\_\_  
Charles R. Reuer

Approved by:

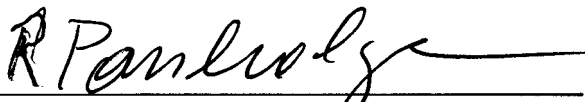
  
\_\_\_\_\_  
Rudy Panholzer, Thesis Advisor

  
\_\_\_\_\_  
Dan Sakoda, Co-Advisor

  
\_\_\_\_\_  
Rudy Panholzer, Dean  
Graduate School of Engineering and Applied Sciences

THIS PAGE INTENTIONALLY LEFT BLANK

## ABSTRACT

The Naval Postgraduate School's current attempt at getting another spacecraft into orbit is focusing on Naval Postgraduate School Spacecraft Architecture and Technology Demonstration Experiment (NPSAT1). Building on lessons learned from PANSAT, in addition to targeting incremental improvements and advances in multiple areas of spacecraft design, NPSAT1 is being built as a three-axis stabilized platform. It will be using commercial-off-the-shelf (COTS) components in many of its subsystems to provide some testing and experimentation on how certain COTS components can handle space environments and the challenges this unique environment presents. Other characteristics of NPSAT1 include a PC-compatible Command and Data Handling (C&DH) subsystem, lithium-ion polymer batteries, a Linux operating system, and Ferroelectric RAM.

NPS possesses a unique ability to educate a large number of service personnel in a wide variety of space-related topics. In particular, NPS is not only able to provide classroom and laboratory education on principles, concepts, philosophies, and historical perspectives of space, but also it can provide the student the opportunity to conduct on-orbit operations and testing of the same spacecraft that were designed and built on the grounds of the NPS campus. This thesis describes the overall NPSAT1 design project, including descriptions of the five experiments onboard, and many of the associated requirements that ultimately lead to a successful mission on orbit.

THIS PAGE INTENTIONALLY LEFT BLANK

## TABLE OF CONTENTS

<b>I.</b>	<b>INTRODUCTION TO NAVAL POSTGRADUATE SCHOOL SATELLITE PROGRAMS .....</b>	<b>1</b>
<b>A.</b>	<b>NAVAL POSTGRADUATE SCHOOL SATELLITE PROGRAMS.....</b>	<b>1</b>
<b>B.</b>	<b>PETITE AMATEUR NAVY SATELLITE .....</b>	<b>2</b>
<b>II.</b>	<b>NAVAL POSTGRADUATE SCHOOL SPACECRAFT ARCHITECTURE AND TECHNOLOGY DEMONSTRATION EXPERIMENT AND SUBSYSTEM DESCRIPTIONS .....</b>	<b>3</b>
<b>A.</b>	<b>STRUCTURES AND MECHANISMS .....</b>	<b>7</b>
<b>1.</b>	<b>Limits .....</b>	<b>9</b>
<b>2.</b>	<b>Tradeoffs.....</b>	<b>12</b>
<b>B.</b>	<b>TELEMETRY AND COMMAND (T&amp;C).....</b>	<b>13</b>
<b>1.</b>	<b>Limits .....</b>	<b>14</b>
<b>2.</b>	<b>Tradeoffs.....</b>	<b>14</b>
<b>C.</b>	<b>THERMAL CONTROL SUBSYSTEM .....</b>	<b>15</b>
<b>1.</b>	<b>Limits .....</b>	<b>16</b>
<b>2.</b>	<b>Tradeoffs.....</b>	<b>17</b>
<b>D.</b>	<b>ELECTRICAL POWER SUBSYSTEM (EPS).....</b>	<b>18</b>
<b>1.</b>	<b>Limits .....</b>	<b>20</b>
<b>2.</b>	<b>Tradeoffs.....</b>	<b>21</b>
<b>E.</b>	<b>ATTITUDE CONTROL SUBSYSTEM (ACS) .....</b>	<b>24</b>
<b>1.</b>	<b>Limits .....</b>	<b>24</b>
<b>2.</b>	<b>Tradeoffs.....</b>	<b>26</b>
<b>F.</b>	<b>COMMAND AND DATA HANDLING (C&amp;DH) .....</b>	<b>26</b>
<b>1.</b>	<b>Limits .....</b>	<b>28</b>
<b>2.</b>	<b>Tradeoffs.....</b>	<b>28</b>
<b>3.</b>	<b>Software .....</b>	<b>28</b>
<b>III.</b>	<b>PAYLOADS.....</b>	<b>31</b>
<b>A.</b>	<b>COHERENT ELECTROMAGNETIC RADIO TOMOGRAPHY .....</b>	<b>31</b>
<b>1.</b>	<b>Description.....</b>	<b>31</b>
<b>2.</b>	<b>Reason for Inclusion .....</b>	<b>32</b>
<b>3.</b>	<b>Ground Stations .....</b>	<b>32</b>
<b>B.</b>	<b>LANGMUIR PROBE .....</b>	<b>33</b>
<b>1.</b>	<b>Description.....</b>	<b>33</b>
<b>2.</b>	<b>Reason for Inclusion .....</b>	<b>34</b>
<b>C.</b>	<b>VISIBLE (WAVELENGTH) IMAGER (VISIM).....</b>	<b>34</b>
<b>1.</b>	<b>Description.....</b>	<b>34</b>
<b>2.</b>	<b>Reason for Inclusion .....</b>	<b>35</b>
<b>3.</b>	<b>Capabilities .....</b>	<b>35</b>
<b>D.</b>	<b>MICRO ELECTRO-MECHANICAL SYSTEMS (MEMS) EXPERIMENT .....</b>	<b>38</b>

1.	Description.....	38
2.	Reason for Inclusion .....	38
E.	CONFIGURABLE PROCESSOR EXPERIMENT .....	39
1.	Description.....	39
2.	Reason for Inclusion .....	39
IV.	LAUNCH ELEMENT .....	41
A.	DEPARTMENT OF DEFENSE SPACE TEST PROGRAM OVERVIEW.....	41
B.	LAUNCH VEHICLE OPTIONS.....	43
1.	Space Shuttle .....	43
a.	<i>Performance Capability</i> .....	44
b.	<i>Availability</i> .....	44
c.	<i>Limitations and Concerns</i> .....	44
2.	Taurus .....	45
a.	<i>Performance Capability</i> .....	45
b.	<i>Availability</i> .....	45
c.	<i>Limitations and Concerns</i> .....	46
3.	Pegasus.....	46
a.	<i>Performance Capability</i> .....	46
b.	<i>Availability</i> .....	46
c.	<i>Limitations and Concerns</i> .....	47
4.	Delta IV .....	47
a.	<i>Performance Capability</i> .....	47
b.	<i>Availability</i> .....	48
c.	<i>Limitations and Concerns</i> .....	48
V.	POST-LAUNCH OPERATIONS .....	51
A.	COMMUNICATIONS STATE: 0 .....	54
1.	Phase Description.....	54
2.	Priorities.....	54
3.	Tradeoffs.....	55
B.	COMMUNICATIONS STATE: 1 .....	55
1.	Phase Description.....	55
2.	Priorities.....	56
3.	Tradeoffs.....	56
4.	Transition from Communications State: 1 .....	56
C.	COMMUNICATIONS STATE: 2 .....	57
D.	COMMUNICATIONS STATE: 3 .....	57
E.	COMMUNICATIONS STATE: 4 .....	58
F.	GENERAL TIMELINE OF ON-ORBIT OPERATIONS .....	58
VI.	CONCLUSIONS AND RECOMMENDATIONS.....	61
A.	LAUNCH VEHICLE.....	61
B.	INITIAL ON-ORBIT OPERATIONS .....	62
C.	PAYLOAD PRIORITY USAGE .....	63
D.	BENEFITS OF NPSAT1 TO NPS.....	64

<b>E.</b>	<b>FOLLOW-ON WORK</b> .....	<b>65</b>
<b>F.</b>	<b>CONCLUSION</b> .....	<b>66</b>
	<b>APPENDIX. LINK BUDGET SPREADSHEET</b> .....	<b>67</b>
	<b>LIST OF REFERENCES</b> .....	<b>69</b>
	<b>INITIAL DISTRIBUTION LIST</b> .....	<b>71</b>

THIS PAGE INTENTIONALLY LEFT BLANK

## LIST OF FIGURES

Figure 1.	System Block Diagram (NPSAT1 Design Overview).....	5
Figure 2.	Configuration of NPSAT1 (NPSAT1 Design Overview).....	8
Figure 3.	Expanded View of NPSAT1 (NPSAT1 Design Overview). ....	9
Figure 4.	ESPA Ring Configuration (NPSAT1 Design Overview). ....	10
Figure 5.	T&C Block Diagram.....	15
Figure 6.	NPSAT1 Subsystem Temperatures I (NPSAT1 Design Overview).....	17
Figure 7.	NPSAT1 Subsystem Temperatures II (NPSAT1 Design Overview). ....	18
Figure 8.	EPS Block Diagram.....	19
Figure 9.	35-Degree Inclination Beta Angle Analysis. ....	22
Figure 10.	60-Degree Inclination Beta Angle Analysis. ....	23
Figure 11.	85-Degree Inclination Beta Angle Analysis. ....	23
Figure 12.	ACS Block Diagram (NPSAT1 Design Overview).....	25
Figure 13.	C&DH (NPSAT1 Design Overview).....	27
Figure 14.	Examples of Compression (After JPEG Compression Example).....	37
Figure 15.	Digital Camera and PC/104 Board (NPSAT1 Design Overview).....	37
Figure 16.	CPE Block Diagram.....	40
Figure 17.	C&DH-controlled States of Communications .....	53
Figure 18.	General Timeline of NPSAT1 On-orbit Operations .....	58
Figure 19.	Power Duty Cycles .....	63

THIS PAGE INTENTIONALLY LEFT BLANK

## LIST OF TABLES

Table 1.	Subsystems and Elements. After Wertz and Larson.....	6
Table 2.	Rate and Attitude Determination Trade-Off (NPSAT ADCS, 2001).....	25

THIS PAGE INTENTIONALLY LEFT BLANK

## LIST OF SYMBOLS, ACRONYMS AND/OR ABBREVIATIONS

AC	Alternating Current
ACS	Attitude Control Subsystem
ADCS	Attitude Determination and Control Subsystem
AFOSR	Air Force Office of Scientific Research
AWG	American Wire Gauge
BIOS	Basic Input/Output System
°C	Degrees Celsius
C&DH	Command and Data Handling
CCAS	Cape Canaveral Air Station
CERTO	Coherent Electromagnetic Radio Tomography
CITRIS	Computerized Ionospheric Tomography Receiver in Space
CPE	Configurable Processor Experiment
DARPA	Defense Advanced Research Projects Agency
DC	Direct Current
DoD	Department of Defense
EDAC	Error Detection and Correction
EELV	Evolved Expendable Launch Vehicle
EOL	End of Life
EPS	Electrical Power Subsystem
ESPA	EELV Secondary Payload Adapter
FM	Frequency Modulation
FRAM	Ferroelectric Random Access Memory
GMSK	Gaussian Minimal Shift Keying
GTO	Geosynchronous Transfer Orbit
kbps	Kilobits per second
$I_x$	Moment of Inertia, x-axis
$I_y$	Moment of Inertia, y-axis
$I_z$	Moment of Inertia, z-axis
IDE	Integrated Drive Electronics
JPEG	Joint Photographic Experts Group
LEO	Low Earth Orbit
LVI	Launch Vehicle Interface
MEMS	Micro Electro-Mechanical Systems
MHz	Megahertz
MOP	Mission Operations Plan
NASA	National Aeronautics and Space Administration
NPS	Naval Postgraduate School
NPSAT1	Naval Postgraduate School Spacecraft Architecture and Technology Demonstration Experiment
NRL	Naval Research Laboratory
O.S.	Operating System

PANSAT	Petite Amateur Navy Satellite
PBEX	Polymer Battery Experiment
PPP	Point-to-point protocol
RAM	Random Access Memory
SAF/AQS	Secretary of the Air Force/ Director of Space and SDI Programs
SERB	Space Experiments Review Board
SEU	Single Event Upset
SHELS	Shuttle Hitchhiker Experiment Launch System
STP	Space Test Program
STS	Space Transportation System
T&C	Telemetry and Command
TEC	Total Electron Content
TMR	Triple Modular Redundant
TT&C	Telemetry, Tracking, and Command
UART	Universal Asynchronous Receiver/Transmitter
VAFB	Vandenberg Air Force Base
VISIM	Visible (Wavelength) Imager
WFF	Wallops Flight Facility

# **I. INTRODUCTION TO NAVAL POSTGRADUATE SCHOOL SATELLITE PROGRAMS**

## **A. NAVAL POSTGRADUATE SCHOOL SATELLITE PROGRAMS**

The Naval Postgraduate School (NPS) possesses a unique ability to educate a large number of service personnel in a wide variety of space-related topics. In particular, NPS is not only able to provide classroom and laboratory education on principles, concepts, philosophies, and historical perspectives of space, but also it can provide the student the opportunity to conduct on-orbit operations and testing of the same spacecraft that were designed and built on the grounds of the NPS campus.

The staff and students at NPS are not necessarily in the business of building satellites. However, even with limited resources, funding, and manpower, the successes of this institution in the small satellite production and operation arena are impressive. The complexities of satellite design, construction, testing, and operation are magnified by the fact that much of the manpower resides in students who are likely to be involved for only about one year. In addition, these students rarely have any background in the space and/or satellite business, so their efforts are not only concentrated on learning about space, but also on applying their newly acquired knowledge toward building a successful product.

In order for an institution such as NPS to be able to make attempts such as spacecraft design, and ultimately reach on-orbit operations, outside sources are necessary. Sponsors are critical players in the overall process, as they not only can provide much of the technical expertise, but they also are the main source of funding for the overall projects. Another service supplier that makes this all possible is the Department of Defense Space Test Program (STP). The reason this is critical is that this program provides access to space via launch vehicles. Launching a spacecraft is always one of the most expensive details in a satellite program, and without the services of the STP, NPS would not likely be able to pursue satellite design programs.

## **B. PETITE AMATEUR NAVY SATELLITE**

The Naval Postgraduate School's first operational small satellite was launched in 1998 on the Space Shuttle Discovery (STS-95). The development and deployment of this spacecraft was a real success for NPS and its space programs. PANSAT, according to its web site hosted by NPS is "a proof of concept, half-duplex, digital spread-spectrum, store-and-forward communications satellite" (PANSAT, 2001). Every NPS satellite produced will likely carry the "proof of concept" label, as every one will have a large complement of student officers playing a part in satellite development for the very first time. Also, the possibility of having several different faculty and staff members playing integral roles in future satellite projects contributes to this accurate label.

PANSAT is currently in orbit, easily surpassing its targeted two-year life span. Some of the spacecraft characteristics include the fact that it is a tumbler, meaning it has no internal stabilization mechanisms. Even without complex attitude control requirements due to this tumbling aspect, there were plenty of other requirements to meet that added complexity to the project: in particular safety requirements due to it being launched on a manned vehicle.

## **II. NAVAL POSTGRADUATE SCHOOL SPACECRAFT ARCHITECTURE AND TECHNOLOGY DEMONSTRATION EXPERIMENT AND SUBSYSTEM DESCRIPTIONS**

The Naval Postgraduate School's current attempt at getting another spacecraft into orbit is focusing on Naval Postgraduate School Spacecraft Architecture and Technology Demonstration Experiment (NPSAT1). Building on lessons learned from PANSAT, in addition to targeting incremental improvements and advances in multiple areas of spacecraft design, NPSAT1 is being built as a three-axis stabilized platform. It will be using commercial-off-the-shelf (COTS) components in many of its subsystems to provide some testing and experimentation on how certain COTS components can handle space environments and the challenges this unique environment presents. Other characteristics of NPSAT1 include the following:

- PC-compatible Command and Data Handling (C&DH) subsystem
- Lithium-ion polymer batteries
- Linux operating system
- Ferro-electric RAM

The design of NPSAT1 was not developed via think tanks and conceptualization from the ground up. Rather, its design was based on inherited hardware components. Since NPS is an educational institution and not a spacecraft laboratory in competition with major contractors, it must take advantage of complimentary acquisitions (i.e. the structure of NPSAT1) to get a project such as NPSAT1 off the drawing board and into space. Compliments of other cancelled programs and projects beyond the walls of NPS, components such as the basic structure and solar cells were obtained free of charge. The inherited structure was the beginning baseline of what the scope of the NPSAT1 project would be.

NPSAT1 is a twelve-sided cylindrical structure composed of aluminum. Its radius is 49.5 cm (19.5 inches) and its height is 93.2 cm (36.7 inches). Flat panels of solar cells will cover each of the sides of the cylinder, as well as the top. The bottom exterior of the structure, that which will be nadir-pointing once on orbit, will be the area

that is not only responsible for attaching to and deploying from the launch vehicle, but it will also house payload items (e.g., a camera package for the digital imaging payload) and other subsystem elements such as an antenna for the T&C subsystem. Initial analysis has resulted in a completed spacecraft weight of approximately 82 kilograms (180 pounds).

For practically all spacecraft design projects, there are a number of subsystems that must be integrated in order to provide the means to support the spacecraft itself, along with any payloads that may be carried by the spacecraft. According to Wertz and Larson, there are seven spacecraft subsystems (1999), and each subsystem has specific issues within itself that require consideration when designing a spacecraft. Many of these issues are listed in Table 1.

In the case of NPSAT1, not every subsystem is identical to the Wertz and Larson description. For example, NPSAT1 will not be tracked directly by the NPS ground station, and therefore “tracking” has been removed from the NPSAT1 Telemetry, Tracking, and Command (TT&C) subsystem, leaving it as just Telemetry and Command (T&C). In addition, the issues referenced in Table 1 may not all be applicable in the design of NPSAT1, either. Such is the case when looking at the Structures and Mechanisms subsystem, specifically the issue of preliminary sizing of structural members. Since NPS was given the basic structure prior to any real design discussions, the issue was not how large or what shape to build, but rather how do we design the other subsystems and payloads to complement the given structure.

The remainder of this chapter will discuss in brief each of the NPSAT1 subsystems, as well as bring out some of the more important factors considered when designing the spacecraft. Figure 1 shows the system block diagram for NPSAT1.

The focus of the system block diagram is the C&DH block right in the center, with the stacked components being attached to the heart of the system, the 80386 processor. This stack includes the Configurable Processor Experiment (CPE) and the modem and memory.

Many of the interfaces are yet to be determined throughout Figure 1, but one identifiable interface is the parallel interface between the VISIM/PC104 and the C&DH block. This interface is possible since the VISIM has its own processor board, a feature that should free up the C&DH 80386 processor resources. As an experimental option, there may be a time when the CPE experiment is used to process or compress VISIM image data without the use of the VISIM's processor.

An attribute of the NPSAT1 project is that its ACS and EPS microcontrollers (80C196KD) are the same. The similarities between these two subsystems provide for an easier design and implementation of software required to operate the specific subsystems.

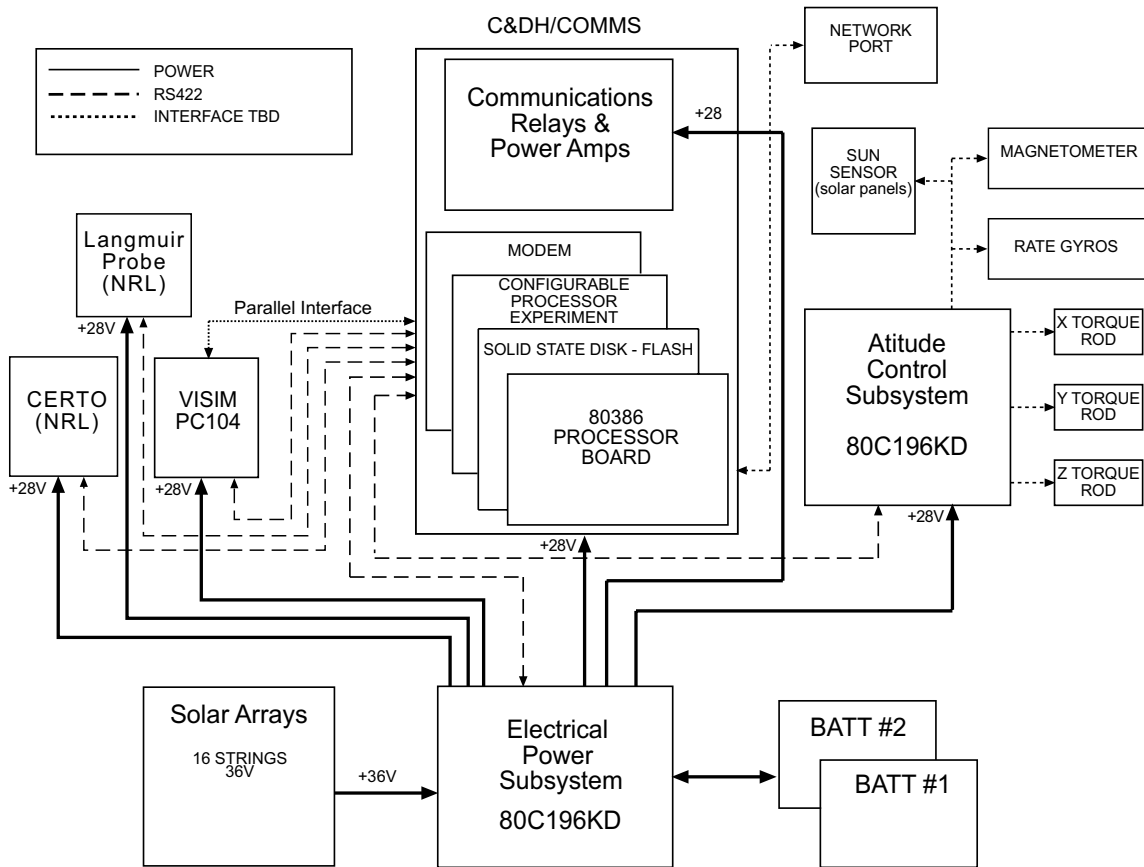

Figure 1. System Block Diagram (NPSAT1 Design Overview).

SUBSYSTEM	ISSUES
Structures and Mechanisms	Structural requirements Packaging and configuring the subsystem Design options Structural design philosophy and criteria Preliminary sizing of structural members Structural mechanics and analysis Mechanisms and deployables
Telemetry, Tracking, and Command	Requirements Designing the TT&C subsystem
Thermal	Principles of heat transfers Thermal control components Thermal subsystem design Thermal analysis concepts Preliminary design process Thermal control design consideration Thermal testing Future trends
Power	Power sources Energy storage Power distribution Power regulation and control
Attitude Determination and Control	Control modes and requirements Selection of spacecraft control type Quantify the disturbance environment Select and size ADCS hardware Define the control algorithms
Command and Data Handling	Introduction to C&DH C&DH system sizing process C&DH basics
Guidance and Navigation	System definition process Orbit determination systems Orbit maintenance and control Sizing autonomous guidance and navigation

Table 1. Subsystems and Elements. After Wertz and Larson.

## A. STRUCTURES AND MECHANISMS

The structure of a spacecraft is just as the name implies: physical structure. The makeup of the structure and any associated mechanisms for the spacecraft have many responsibilities, from providing a place for other components to be attached, to containing and protecting sensitive equipment, to providing a means for the spacecraft to be connected to a launch vehicle. Stringent reliability requirements make the structures and mechanisms subsystem as important as any other subsystem.

The fact that NPS was given the primary physical structure made some of the specific structural design issues overcome by events. The design philosophy was less driven by a set of requirements on the outside, than by the requirements to fit all other subsystem elements and payload items on the inside of the structure. Minor external changes could be, and inevitably will be, made to the primary structure as other tradeoffs and issues present themselves. However, having such a good starting point from a structural standpoint proved valuable in being able to decide how many, what type, and what size components could be handled by the structure. Also, being able to see and touch such an item, and not have to rely solely on drawings or interpretations of what the structure may possibly look like was an added benefit in more ways than just saving on the machining cost. It is important to note, however, that the requirement for reverse engineering is present, to ensure new designs and modifications are doable and appropriate. Figure 2 and Figure 3 show different views of the NPSAT1 configuration.

Figure 2 (a) shows the top of NPSAT1, which will be zenith pointing. Figure 2 (b) shows the stowed configuration of the CERTO antenna and Langmuir probe, both of which will be deployed in the orbit normal, or +/- Y direction. Figure 2 (c) is a representation of NPSAT1 in its “upright” profile, which will be its orbiting position with the bottom of the figure being nadir pointing. Figure 2 (d) is an isometric view.

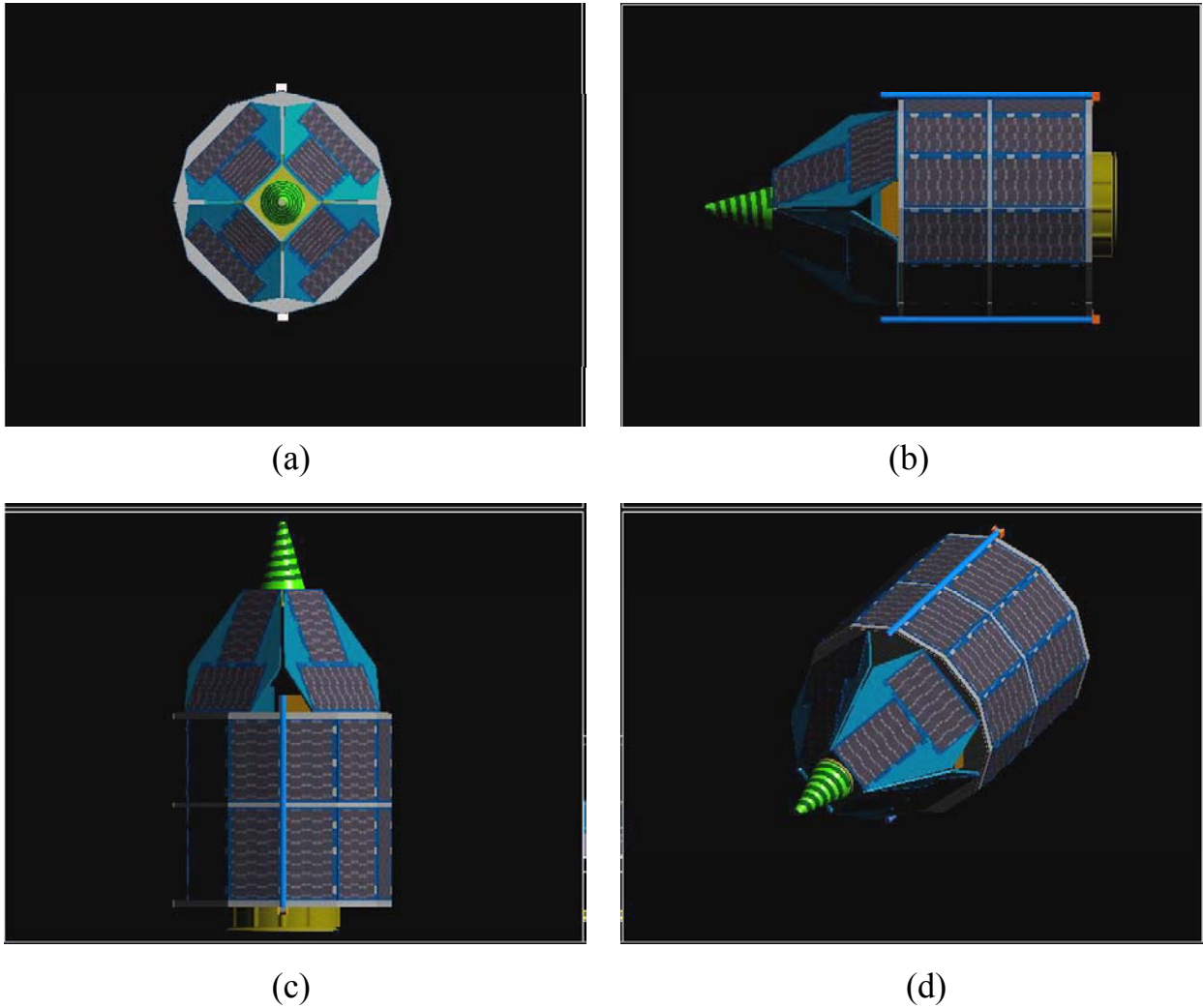

Figure 2. Configuration of NPSAT1 (NPSAT1 Design Overview).

Figure 3 is self-explanatory. Note the X, Y, Z vector key on the bottom left of the figure: +X is the velocity vector, +/-Y is the orbit normal, +Z is zenith, and -Z is nadir pointing.

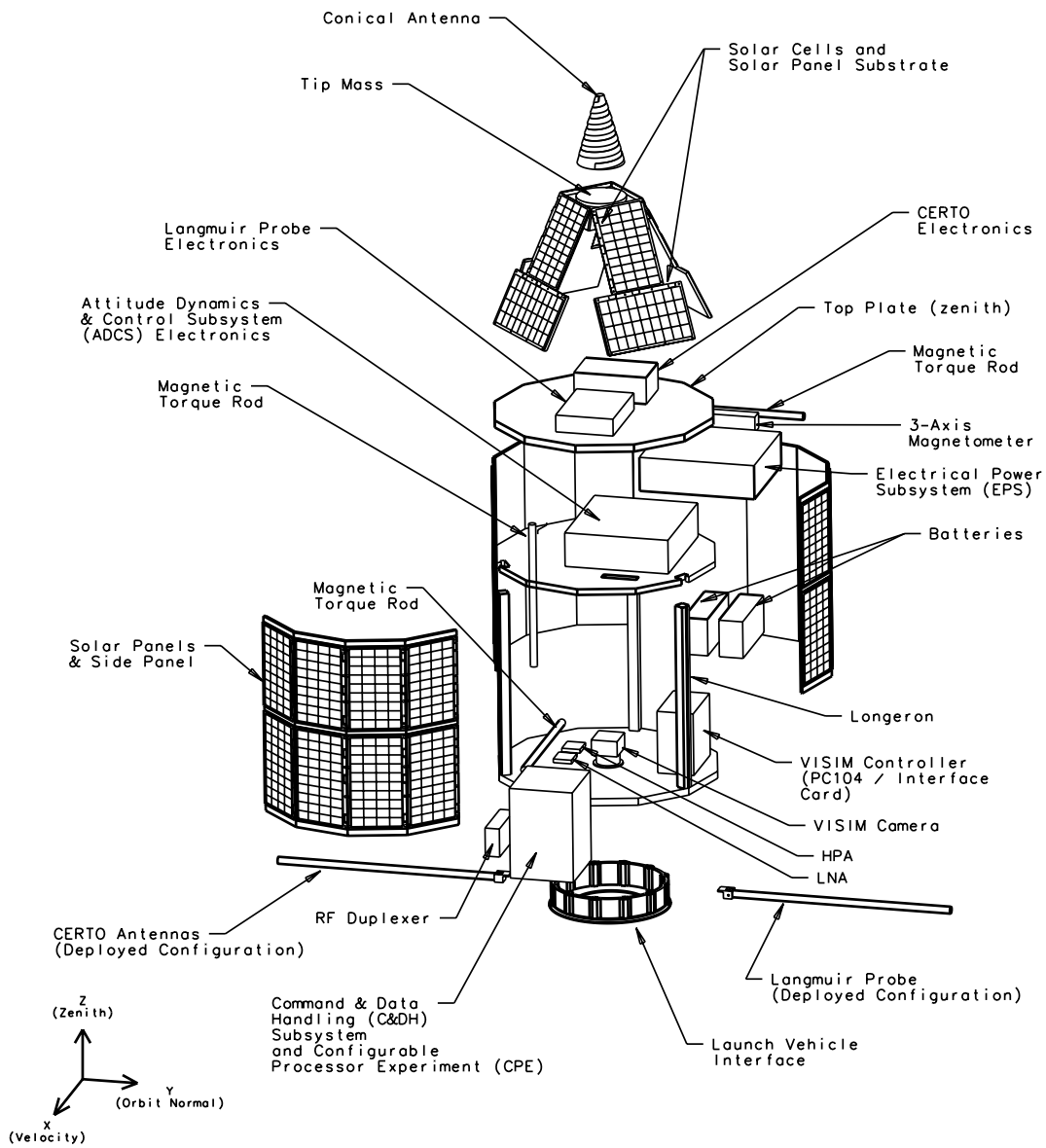

Figure 3. Expanded View of NPSAT1 (NPSAT1 Design Overview).

## 1. Limits

The limits on the physical structure are such that all the components must fit within the volume and weight allotted to NPSAT1 inside the launch vehicle fairing, as well as reside inside or on the spacecraft in such a way so as to not interfere with items

such as the following examples: other elements of NPSAT1 (i.e. camera visibility), other spacecraft or mechanisms within the launch vehicle, and the launch vehicle fairing itself. Since NPSAT1 has been selected to be launched on a Delta IV launch vehicle using the EELV Secondary Payload Adapter (ESPA) ring, the structure must fit within a .61m x .61m x .97m (24 x 24 x 38 inch) volume, and less than 181 kilograms (400 pounds). Figure 4 depicts the volume measurements in inches.

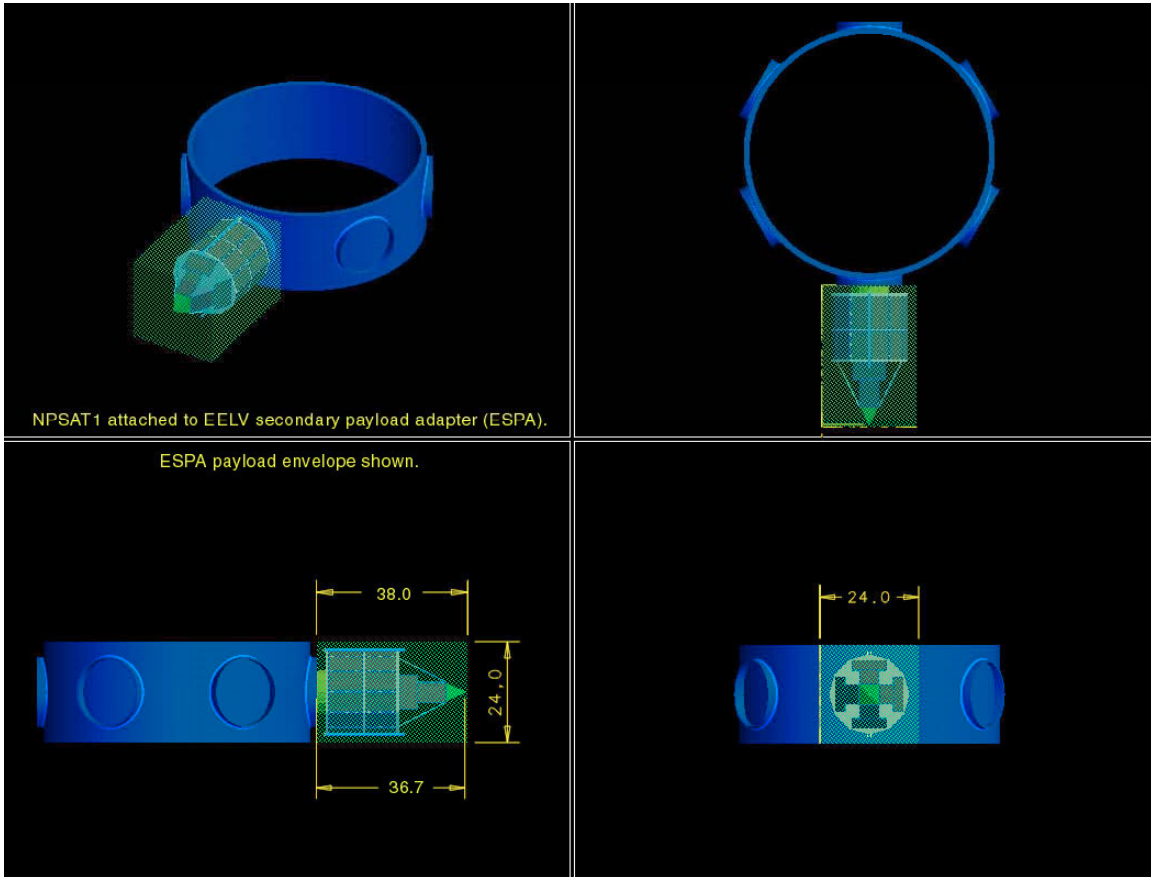

Figure 4. ESPA Ring Configuration (NPSAT1 Design Overview).

One area of critical consideration in the design and placement of internal components is related to moments of inertia, the center-of-gravity, and center-of-pressure. A key is that the center-of-pressure and center-of-gravity of the structure need to be as close to the same point as possible, resulting in a lowering of the disturbance due to aero torques. Accomplishing this will assist our low-budget attitude control efforts to the maximum extent possible with minimal mechanical equipment required. Since this is

a three-axis stabilized spacecraft designed with a limited budget, co-location of these centers will greatly assist in attitude control.

Another area considered in designing the internal layout of payload and subsystem components was moments of inertia. Again, the ability to produce such a low budget spacecraft with three-axis stabilization requires maximizing the “laws of nature” to produce desired effects on the structure. The principal moments of inertia need to be aligned with the spacecraft orbital coordinates while having desired values such that  $I_y > I_x > I_z$ , where  $I_y$  is the moment of inertia about the Y (orbit normal) axis,  $I_x$  is the moment of inertia along the X (velocity vector) axis, and  $I_z$  is the moment of inertia about the Z (zenith/nadir) axis. Based on input values from provided equipment lists and computer-simulated modeling, the moments of inertia values met this desired formula, but not with enough separation or difference to provide a level of confidence which was strong enough to settle on the design. As a backup plan, it was determined that the option of adding a boom may be necessary in the event the ACS performance is unstable.

The boom concept is nothing new in the spacecraft business, but it adds a level of structural complexity that had not been predicted. However, due to the fact that this concept has an established history in many spacecraft designs, confidence is relatively high that the incorporation of a boom and its associated mechanisms will not provide additional delays and/or complications to the NPSat1 production if it is in fact deemed necessary. NPS possesses a stacer boom that is approximately 67 inches in length when fully deployed, and adding a tip mass of approximately ten kilograms would greatly contribute to NPSAT1’s stability if required. The maximum benefit will be gained by the further the tip mass is away from the spacecraft’s main structure. The current plan is for the boom to be included in the spacecraft, but the actual boom deployment is being reserved as a contingency in case the ACS is unable to establish the necessary stabilization in orbit.

Separation and deployment mechanisms will be limited to the following: a simple deployment mechanism for the CERTO antenna and Langmuir probe, the possible boom deployment mechanism, and the launch vehicle separation mechanism. The CERTO antenna and Langmuir probe do not yet have deployment mechanisms in place, but a

possible deployment mechanism will consist of running minimal current through an attachment wire to free the spring-loaded mechanism to pull the antennas into operating position. Deployment of the boom may not be much more complicated, but it may bring safety considerations into the design if pyrotechnics are involved. A candidate for the launch vehicle separation system is known as a Lightband separation system. According to material from the AFOSR and DARPA University Nanosatellite Program, Lightband separation systems offer several advantages, such as the following:

- Lighter
- Less intrusive to other components
- Easier to design, test, and reset
- Safer and low shock (no pyrotechnics)
- Inexpensive to test
- Rapidly manufactured (Holemans, 1999).

In addition to these benefits, another factor in the possible selection of this separation system is that at least one other secondary payload on NPSAT1's scheduled launch vehicle is already planning on using a Lightband system. Using a common separation system for all of the secondary payloads will prove beneficial when it comes time for the integration of the secondary payloads with the launch vehicle.

## **2. Tradeoffs**

Externally, the structure is relatively straightforward, with little room for change on any area, except for the top of the spacecraft. Further study and analysis will be conducted as the spacecraft is constructed and components are placed into position. A recent design change incorporates a pyramidal top section represented in Figure 2, as initial designs produced a flat top section. Another possibility is to have a boom or other structure to provide for necessary gravity gradient requirements.

## B. TELEMETRY AND COMMAND (T&C)

NPSAT1's subsystem of telemetry and command will be a difficult challenge in this design project. This subsystem conducts the communications exchange between the spacecraft and the ground station. It will serve as the interface between the C&DH subsystem data and the RF energy to/from the ground station. The responsibilities of NPSAT1's T&C subsystem include the following:

- Receive transmissions from the ground station.
- Modulate/demodulate signals for communications exchange between NPSAT1 C&DH and the ground station.
- Transmit processed subsystem data to ground station.

Refer to Figure 5 for the T&C block diagram.

The Space and Missile Systems Center in Los Angeles coordinated the allocation of the uplink and downlink frequencies, 1.7 GHz and 2.2 GHz, respectively. NPSAT1 will have two antennas. One is providing hemispherical coverage in the zenith direction, and the other is providing hemispherical coverage in the nadir (Earth-pointing) direction. The combination of these two antennas will yield  $4\pi$  steradian coverage. Both antennas will be capable of communicating via uplink and downlink frequencies. Specific operations of these antennas will be discussed in Chapter V.

Within the T&C system will be a Modem/Data Interface with the processor board that will comply with the PC/104 specification. One feature of the T&C subsystem is shown near the bottom right of Figure 5, that being the GMSK Modulator. GMSK, or Gaussian Minimal Shift Keying, is a method of increasing or maximizing data speed. According to MXCOM Incorporated,

In a GMSK system, the digital bit stream to be transmitted is passed through a Gaussian low pass filter. A Gaussian filter is a filter which when excited by an impulse outputs a Gaussian shaped output pulse. When a digital bit stream is passed through such a filter, a marked reduction in transmission bandwidth occurs. In an optimum GMSK system, 8000b/s should pass through a 12.5kHz FM radio channel. The FM deviation should also be set to be equal to one-half of the data rate. For example, an 8000b/s GMSK data signal should be transmitted with a peak deviation of

4kHz or +/- 2kHz. Within the design of a GMSK system the maximum data rate, the bandwidth employed and the bit error rate can be traded against one another. The method described here provides an approximation to true GMSK. While not in-line with the textbook definition of GMSK, it still provides a simple and effective implementation of a GMSK system. (MXCOM, 2001)

## **1. Limits**

Since NPSAT1 is a relatively small spacecraft, much of the limiting factors are going to be directly related to physical sizes and capabilities. Communications within the spacecraft probably will not suffer extensively due to these physical constraints, but where the limitations will be most evident will be in areas that require excessive power for ideal operation. An example of this will be the telemetry portion, where NPSAT1 and the NPS ground station will likely operate via a 100 kbps data rate link.

## **2. Tradeoffs**

The T&C subsystem does not have a significant number of tradeoffs to consider. Most of the components were either designed or chosen based on a variety of concerns, including power requirements, gain figures, noise figures, and appropriate frequency ranges. Other physical components, such as the antennas, may run into some tradeoff issues once the exterior structure decisions are complete, as any type of protruding device (such as an antenna) can cause issues of concern with not only the Structures and Mechanisms subsystem, but also with the launch vehicle. The entire link budget spreadsheet is in the Appendix.

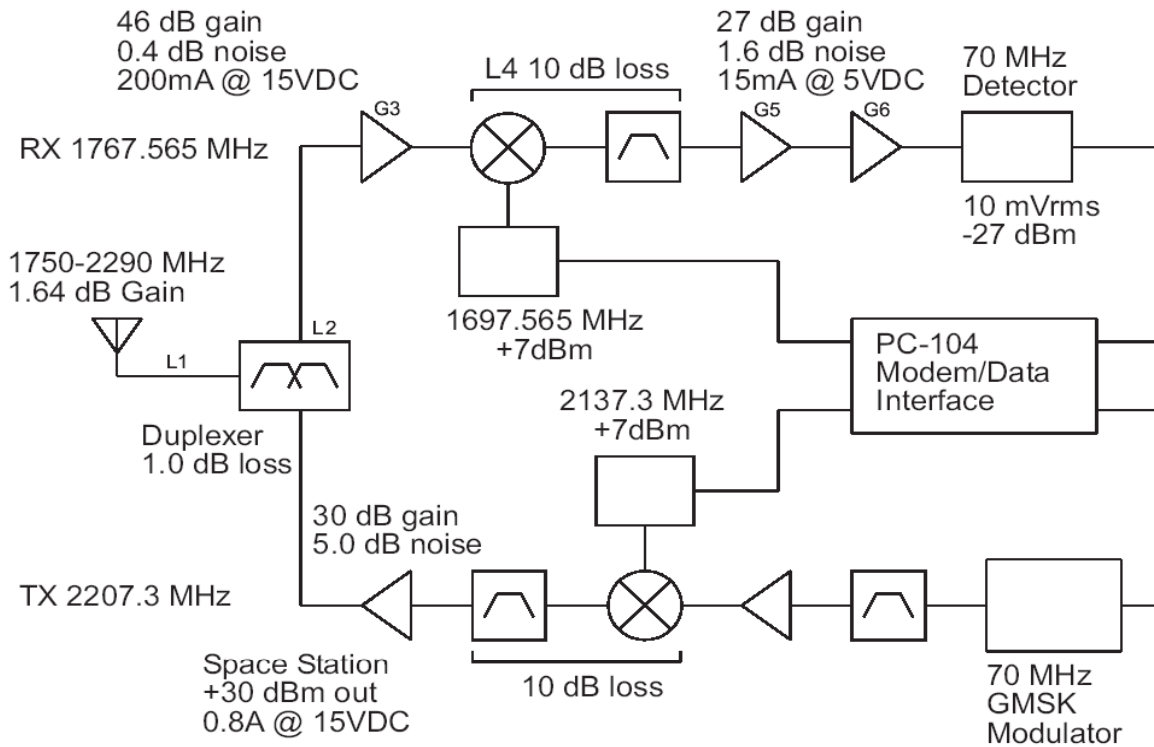

Figure 5. T&C Block Diagram

### C. THERMAL CONTROL SUBSYSTEM

In order for any spacecraft to operate its components effectively, it must be able to withstand some potentially extreme cases of both hot and cold environments in space. In order to effectively handle the rapidly changing temperature environments common to space, the Thermal Control Subsystem takes an active role in maintaining a satellite's temperature within acceptable ranges.

In the case of NPSAT1 and some preliminary thermal analyses, it was discovered that the extreme cases of hot and cold would be around +45° C and -88° C (AA4831, 2000). Many orbital factors contribute to the thermal environment, with variations in orbit altitude and the sun's beta angle being the largest contributors.

## 1. Limits

Internal to the spacecraft, the components considered most reliant on a controlled thermal environment were the digital camera processor and the batteries of the Electrical Power Subsystem. The ideal operating temperature for the batteries has been determined to be 10° C, with an acceptable range from 0 - 45° C. The digital camera processor had a similar upper limit near 45° C, but its range extended below zero to a minus 10° C.

Designing an effective Thermal Control Subsystem requires an understanding of energy and its transportation, specifically in space. Three major areas of heat/energy transfer are radiation, conduction, and convection. Their definitions are listed below:

- Radiation – energy transfer via electromagnetic waves
- Conduction – thermal energy transfer through matter in the absence of fluid motion
- Convection – thermal energy transfer between a flowing fluid and a solid interface. (Wertz and Larson, 1999) Note: convection is not applicable in space due to the negligible gravity, required for convection to occur.

One of the most significant sources of energy would be the heat transferred from the solar panels to the aluminum backbone structure of the spacecraft, and further to the plates used to secure any of the internal subsystem components and payload components. An additional source of heat on the relatively “cold” NPSAT1 spacecraft would be the batteries.

As a result of analysis conducted by AA4831 students, in addition to temperature observations made by PANSAT, it was determined that NPSAT1 will generally be a “cold” spacecraft, and that heating would be necessary for the batteries. Figures 6 and 7 show results of thermal analysis, with each individual component stabilizing at acceptable temperatures or ranges.

The method of choice for monitoring the spacecraft temperature is the placement of thermistors in various locations of concern. Thermistors are sensitive to temperature changes, and they will assist in triggering heating elements within the structure to

compensate for temperatures that approach or exceed predetermined thresholds. This will require coordination with the Command and Data Handling (C&DH) Subsystem.

## 2. Tradeoffs

Due to the assessment and analysis that NPSAT1 would be operating in a relatively benign thermal environment, tradeoffs were not a major consideration or point of contention during the design process. Most of the issues would evolve with the specific placement of components within the structure, allowing for a certain degree of passive thermal control, thereby limiting the amount of overall power required for the operation of any electric heaters.

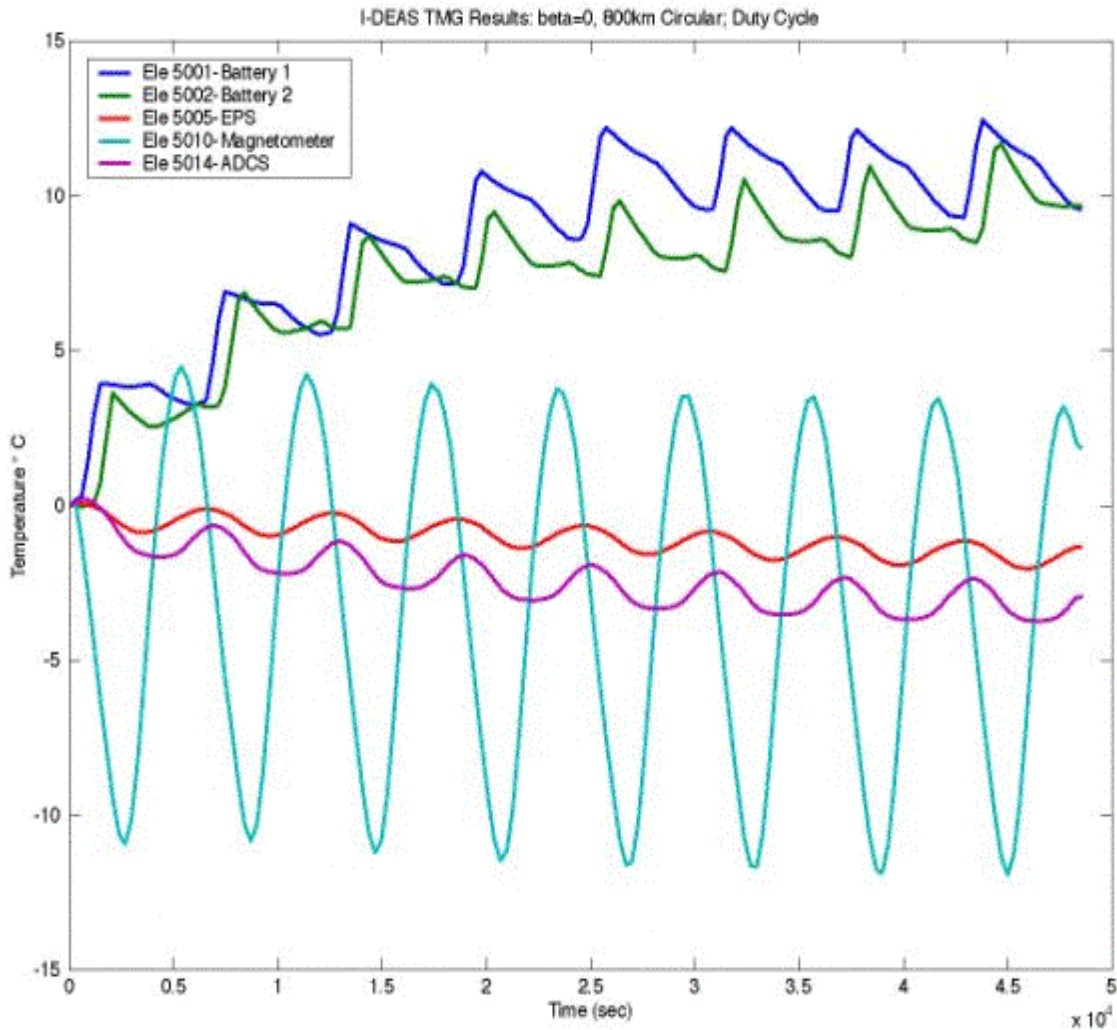

Figure 6. NPSAT1 Subsystem Temperatures I (NPSAT1 Design Overview).

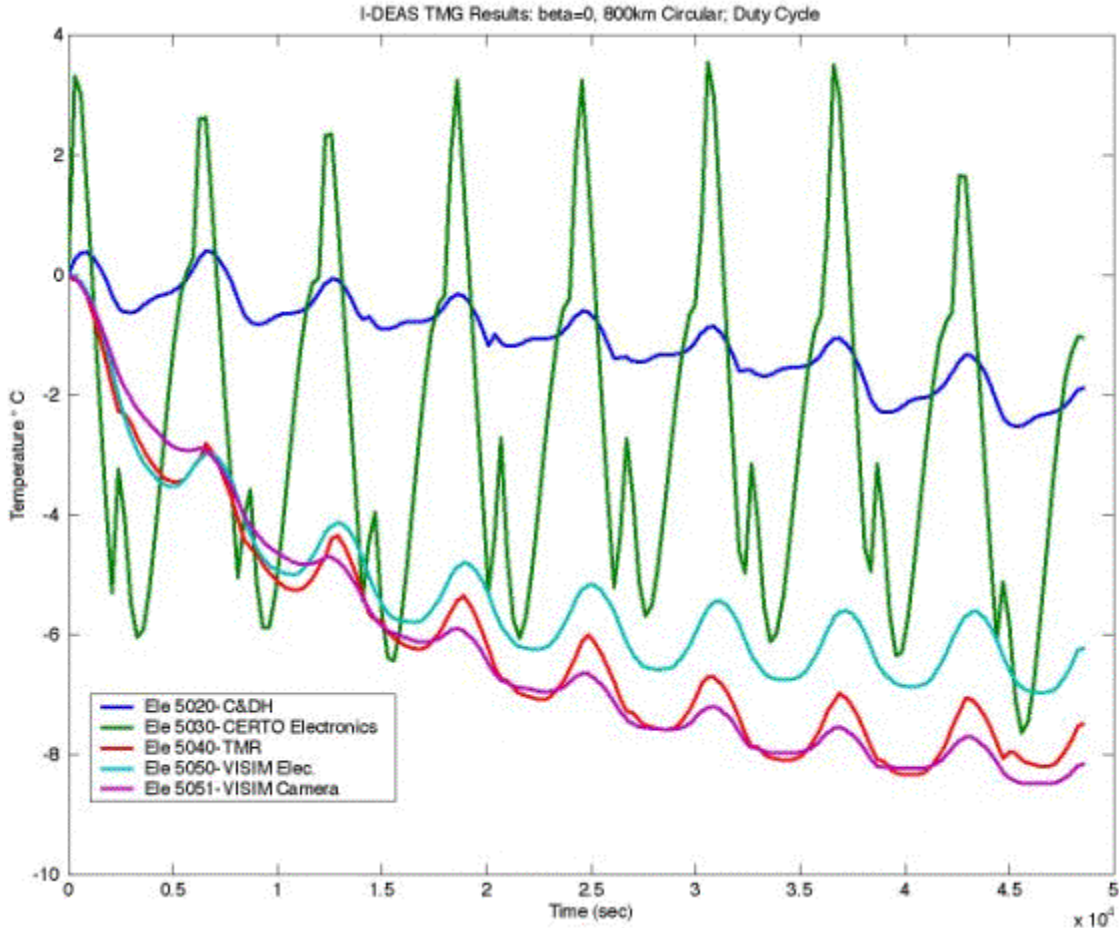

Figure 7. NPSAT1 Subsystem Temperatures II (NPSAT1 Design Overview).

#### D. ELECTRICAL POWER SUBSYSTEM (EPS)

The Electrical Power Subsystem is responsible for functions such as energy storage, distribution, and control on the spacecraft. The fact that NPSAT1 is such a small spacecraft, with a relatively large number of payloads, makes this subsystem one of the most challenging to design and operate. The small number of solar cells on the structure, combined with the fact that less than half of these solar cells will be receiving direct solar energy at any one time makes the issues of energy conservation and effective energy distribution that much more critical. Efficient hardware, especially that hardware which is responsible for the collection and storage of solar energy will be large contributors to the level of success this spacecraft's operations experience.

The EPS block diagram is shown in Figure 8. NPSAT1 will not have the most efficient solar cells on the market covering the entire spacecraft, but may be fortunate to at least have the top, angled portion cells be of an increased efficiency provided by triple-junction cells. The sides of the structure will be Silicon cells. A Launch Vehicle Interface (LVI) is used for electrical connectivity to the launch vehicle, and will be used to provide trickle charging for the NPSAT1 batteries once it is integrated to the launch vehicle and prior to launch. The two NPSAT1 batteries are Lithium-ion polymer cells with a capacity of 106 Watt-hours (3.6 Ampere-hours) each, and are considered an experiment on NPSAT1, even though they are the only energy storage devices being used. This battery technology is being flown on PICOSAT, named the Polymer Battery Experiment (PBEX), with a launch scheduled for September 2001.

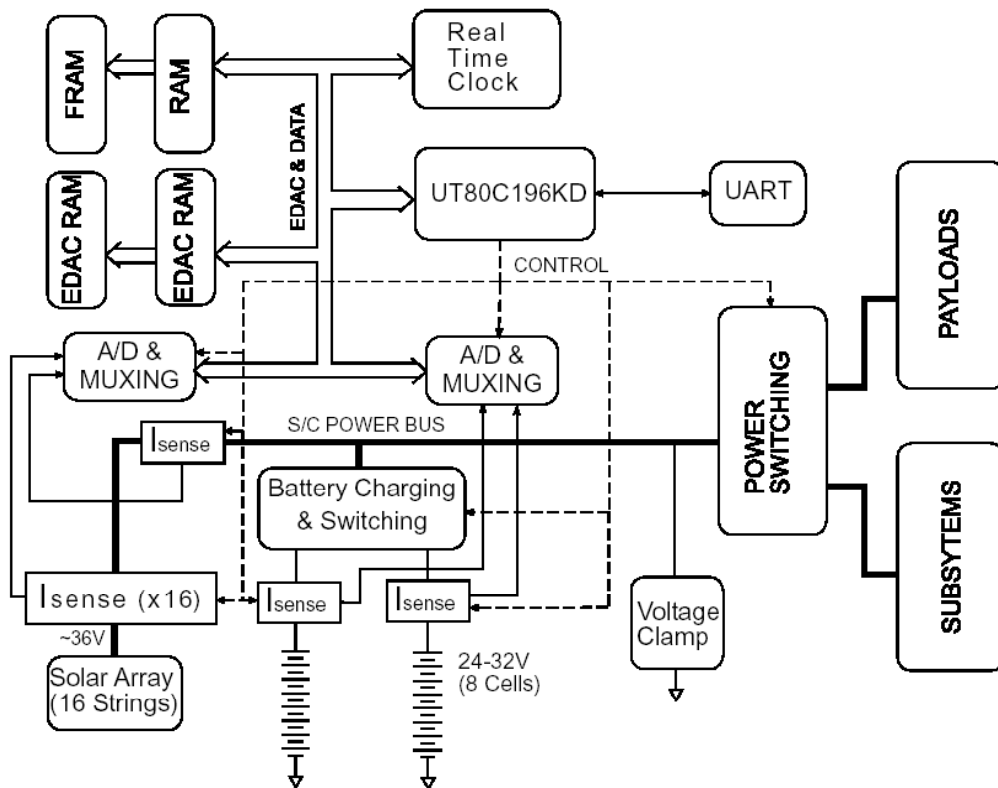

Figure 8. EPS Block Diagram

The EPS microcontroller (UT80C196KD) is identical to the one in the C&DH subsystem. Not all of the memory supporting the EPS is traditional; another experiment, ferroelectric RAM (FRAM), is being used in the EPS. FRAM is nonvolatile, and is also radiation hard. Other functions of the EPS include analog/digital conversion, as well as multiplexing (muxing). Some of the sensors within the EPS are current sensors ( $I_{\text{sense}}$ ), and others are temperature sensors. The temperature sensors are particularly important as they provide valuable feedback to ensure the operating temperatures of these batteries stay within the prescribed limits.

When conceptualizing and designing an EPS, several functions and subfunctions must be taken into consideration. According to Wertz and Larson, the following lists functions of a typical top-level EPS:

- Supply a continuous source of electrical power to spacecraft loads during the mission life.
- Control and distribute electrical power to the spacecraft.
- Support power requirements for average and peak electrical load.
- Provide converters for ac and regulated dc power buses, if required.
- Provide command and telemetry capability for EPS health and status, as well as control by ground station or autonomous system.
- Protect the spacecraft payload against failures within the EPS.
- Suppress transient bus voltages and protect against bus faults.
- Provide the ability to fire ordnance, if required. (1999)

## **1. Limits**

As was previously mentioned, a major limitation in the NPSAT1 design project was the amount of available power. Having said this, there are still requirements to run the various payloads effectively, while simultaneously maintaining a healthy spacecraft. Armed with this awareness, all analysis of the EPS and its power availability numbers was conducted as worst-case scenarios, and calculated for end of life values. The result

was that using 14-15% efficiency for the Silicon solar cells, the two-year end of life power would be 22.8 Watt-hours of energy available per orbit.

## **2. Tradeoffs**

Due to the unique circumstance of NPSAT1 and several of its components coming to NPS free of charge, the actual tradeoffs were minimal in the EPS arena. One area that is often debated is the type of batteries. Since NPSAT1 is employing COTS technology that is yet to be space-applied, Lithium-Ion polymer batteries were selected as the batteries of choice. Historically, space-qualified batteries consisted of either Nickel-Cadmium or Nickel-Hydrogen, so the attempt by the NPSAT1 design project team to go with a developmental battery type such as Lithium-Ion polymer could prove advantageous for future space applications. Batteries are typically rated according to specific energy density, and most Lithium-Ion variants carry a specific energy density that is typically three to five times higher than that of Nickel-Cadmium alternatives. There are not a large number of known space experiments in progress that are exploring Lithium-Ion polymer batteries for energy storage. In addition to the PBEX on Picosat, two instances were found, with one of them, TechSat-21, being a secondary payload on the same launch as NPSAT1. The other experiment, Water Inclination Topography and Technology Experiment, is being pursued as a future technology demonstration at Johns Hopkins University's Applied Physics Laboratory (Johns Hopkins, 2001).

Another potential tradeoff lies in the photovoltaic solar cells. Again, NPS was given the current silicon cells as a result of a previously cancelled Navy project. The option to purchase more efficient cells, such as Gallium Arsenide, Indium Phosphide, or a triple-junction solar cell configuration is being pursued, leading to better power availability for the lifetime of the project. Wertz and Larson have published values for solar cell efficiencies, and silicon averages approximately 14.8% efficient, Gallium Arsenide and Indium Phosphide both surpass 18% efficiency (1999), and triple-junction cells have advertised efficiency as near 24%. This may appear as an insignificant difference of only a few percentage points; but in the life cycle of a spacecraft, especially

a spacecraft with such a tight electrical power budget, even minor differences in solar cell efficiency can have a large impact on spacecraft operations and effectiveness.

Not necessarily a tradeoff, but another area worth mentioning here is the issue of orbital differences and the effects different orbits can have on NPSAT1. Since NPSAT1 will be launched as one of several secondary payloads on the launch vehicle, the design team could only hope for a favorable orbit altitude and inclination. There are best and worst-case scenarios when considering orbital options, but since NPS had no influence on the type of orbit NPSAT1 would ultimately be injected into, the analysis could only be built around various combinations of high and low altitudes, both mixed with other various combinations of high and low inclinations. Some examples of altitude and inclination analysis, in terms of the beta angle between NPSAT1 and the sun are in Figure 9, Figure 10, and Figure 11.

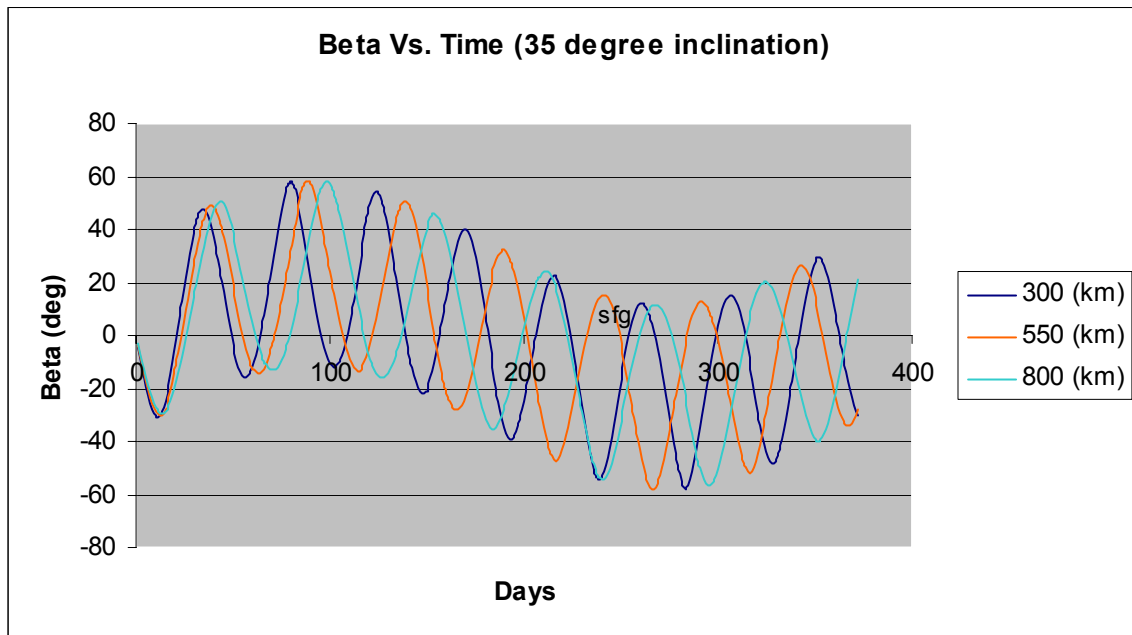

Figure 9. 35-Degree Inclination Beta Angle Analysis.

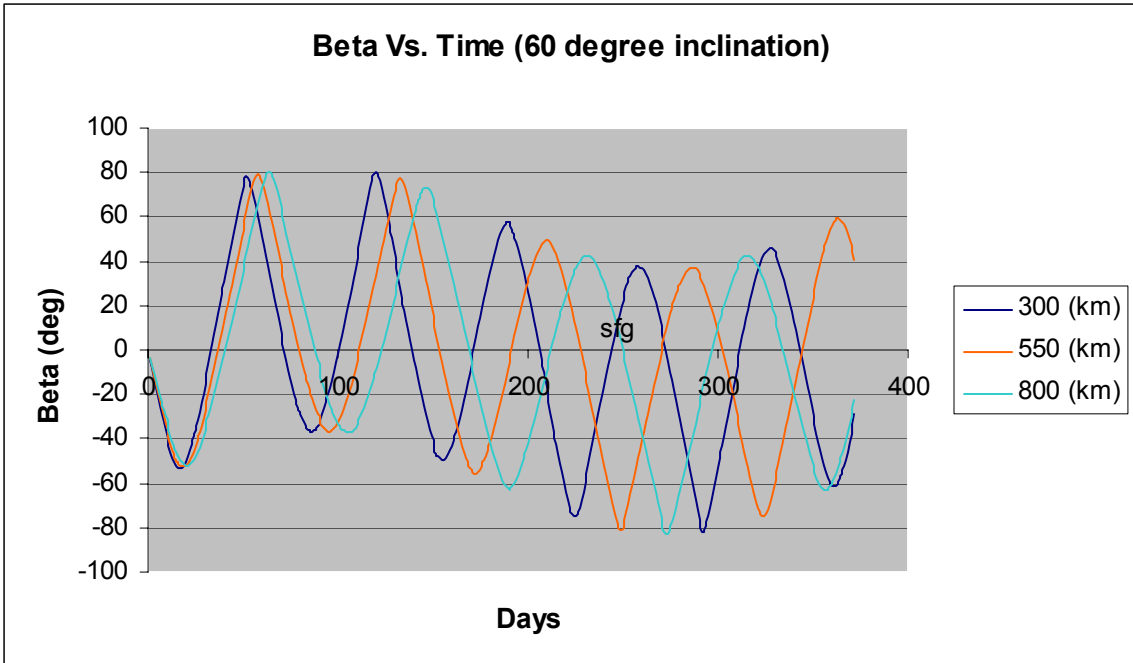

Figure 10. 60-Degree Inclination Beta Angle Analysis.

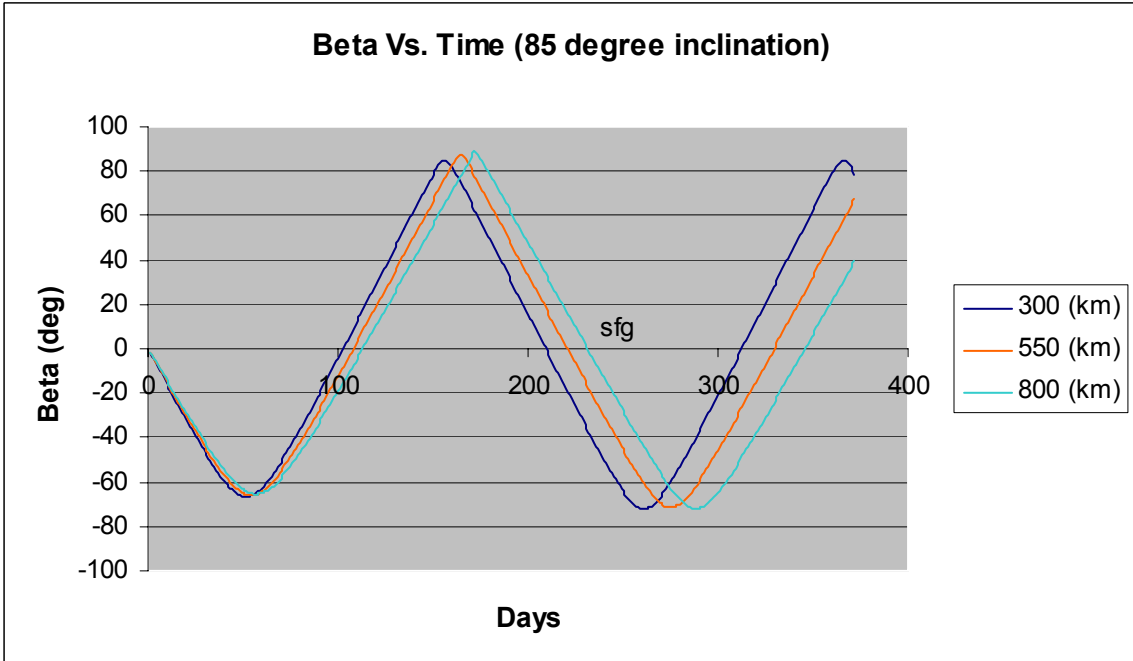

Figure 11. 85-Degree Inclination Beta Angle Analysis.

## **E. ATTITUDE CONTROL SUBSYSTEM (ACS)**

One of the biggest differences in the design of NPSAT1 from that of the already successful PANSAT was the inclusion of a three-axis stabilization design. Since the design and component layout is going to be directed at producing a gravity gradient friendly spacecraft, the hope is that the requirement for attitude control will be minimal enough to be handled with magnetic torque rods.

The critical component of a successful ACS for NPSAT1 will be the software. Sensors such as magnetometers and sun sensors will provide the input for the software to process, ultimately leading to a controlled spacecraft whose attitude enables the payloads to be able to carry out their designed missions.

The ACS block diagram in Figure 12 shows that there will be an option of including or excluding input from the Micro Electro-Mechanical Systems (MEMS) rate sensors; MEMS will be discussed later. The primary sensor is the three-axis magnetometer, with the actuators being three magnetic torque rods, or torquers. The clock, orbit propagator, and magnetometer are critical to the ACS, as they provide the necessary inputs to the various algorithms that ultimately control NPSAT1's attitude.

### **1. Limits**

Design limitations for the ACS fell victim to the same space and power limitations as have been previously mentioned. Larger spacecraft typically use reaction or momentum wheels to provide the larger amounts of torques necessary to stabilize the spacecraft. However, space, power, and budgetary limitations on NPSAT1 dictate that the only real options for ACS active components are torque rods. Table 2 shows rate and attitude determination tradeoffs.

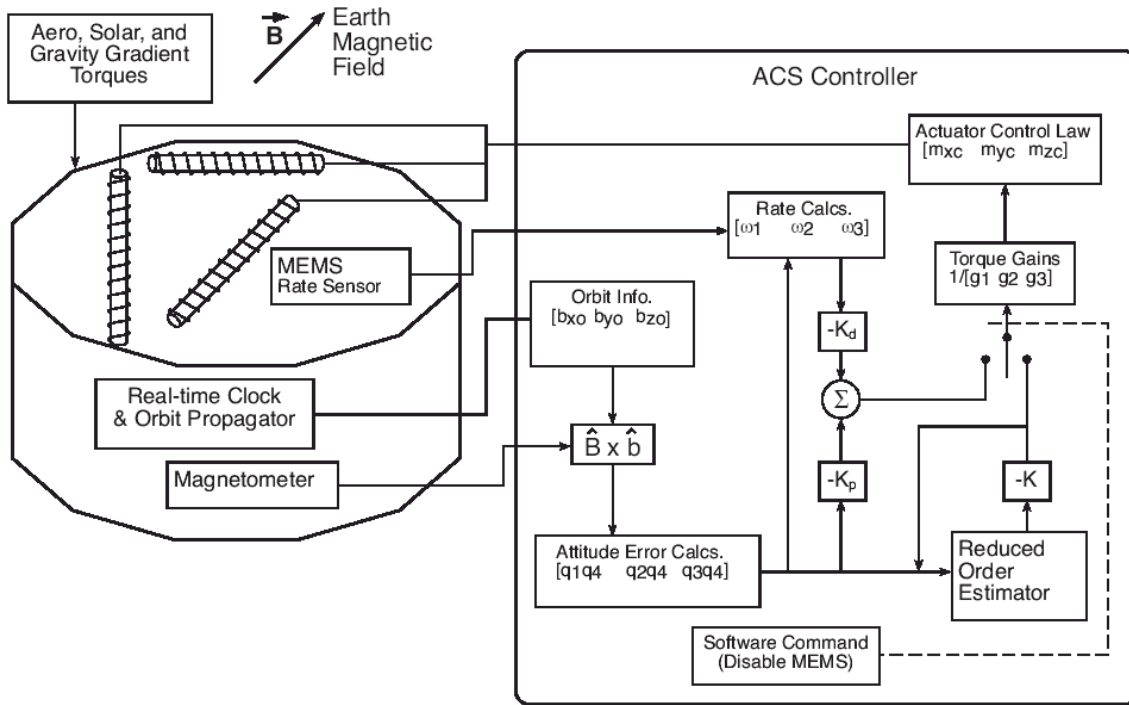

Figure 12. ACS Block Diagram (NPSAT1 Design Overview).

Option	Rate	Attitude		Steady State Error~deg	Acquisition Time~revs	Option Characteristics			
		Day	Night			Sensor Suite	Power ~W	$\Delta$ Cost ~K\$	$\Delta$ Mass ~kg
1*	Estimator	Mag	Mag	1.5	5 $\rightarrow$ 24	Mag	1.2	--	--
2**		Quat	Mag	1.3		Mag + SS	1.8	6	0.9
3		Quat	Quat	0.4		Mag + HS	2.2	80	1
4	Gyro	Mag	Mag	0.6	4 $\rightarrow$ 8	Mag + Gyro	4.6	11	0.2
5		Quat	Mag	0.5		Mag + SS + Gyro	5.2	17	1.1
6		Quat	Quat	0.4		Mag + HS + Gyro	5.6	91	1.2

\* Magnetometer based control law

\*\* Quaternion based control law (magnetometer vector + sun or nadir vector)

\*\*\* Acquisition time is initial condition dependent (attitude, rate, true anomaly and lat/lon)

$\Delta$ Cost = hardware cost only

SS = sun sensor

HS = horizon sensor

Table 2. Rate and Attitude Determination Trade-Off (NPSAT ADCS, 2001)

A limitation caused by funding and power issues may be present in the area of either sun sensors or horizon sensors. These components would input valuable information into the algorithms required to calculate the most effective attitude control and spacecraft stabilization. However, with limited fiscal and electrical power budgets for the NPSAT1 project, reliance will primarily need to be put on the magnetometers and the information they can provide to contribute to the overall success of the Attitude Control Subsystem.

## **2. Tradeoffs**

The issues considered when designing what type of ACS components would suffice for NPSAT1 were related to physical and fiscal limitations. The combination of output torque, physical size, and power requirements were the drivers when deciding on the type of actuators to pursue. Reasonable expenses could be incurred in obtaining both the magnetometers and the torque rods.

## **F. COMMAND AND DATA HANDLING (C&DH)**

In order for a spacecraft such as NPSAT1 to be autonomous, there needs to be a vehicle for handling and distributing the various command information. Therein lies the mission of the Command and Data Handling Subsystem. Figure 13 is the C&DH block diagram. According to Wertz and Larson,

The command and data handling system, C&DH, performs two major functions. It receives, validates, decodes, and distributes commands to other spacecraft systems and gathers, processes, and formats spacecraft housekeeping and mission data for downlink or use by an onboard computer. This equipment often includes additional functions, such as spacecraft timekeeping, computer health monitoring (watchdog), and security interfaces. (1999)

Note: NPSAT1's watchdog timer is actually in the EPS.

As a key to Figure 13, the red and italicized text represents those items that are uniquely created and controlled by the NPSAT1 design team. The regular text depicts items that are either COTS or otherwise pre-existing.

The PPP Link is a point-to-point protocol link, similar to those links that use dial-up methods common between households and Internet Service Providers across the world today. The device using the PPP Link is a UART, or Universal Asynchronous Receiver/Transmitter, which is a chip that has both a receiver and a transmitter section.

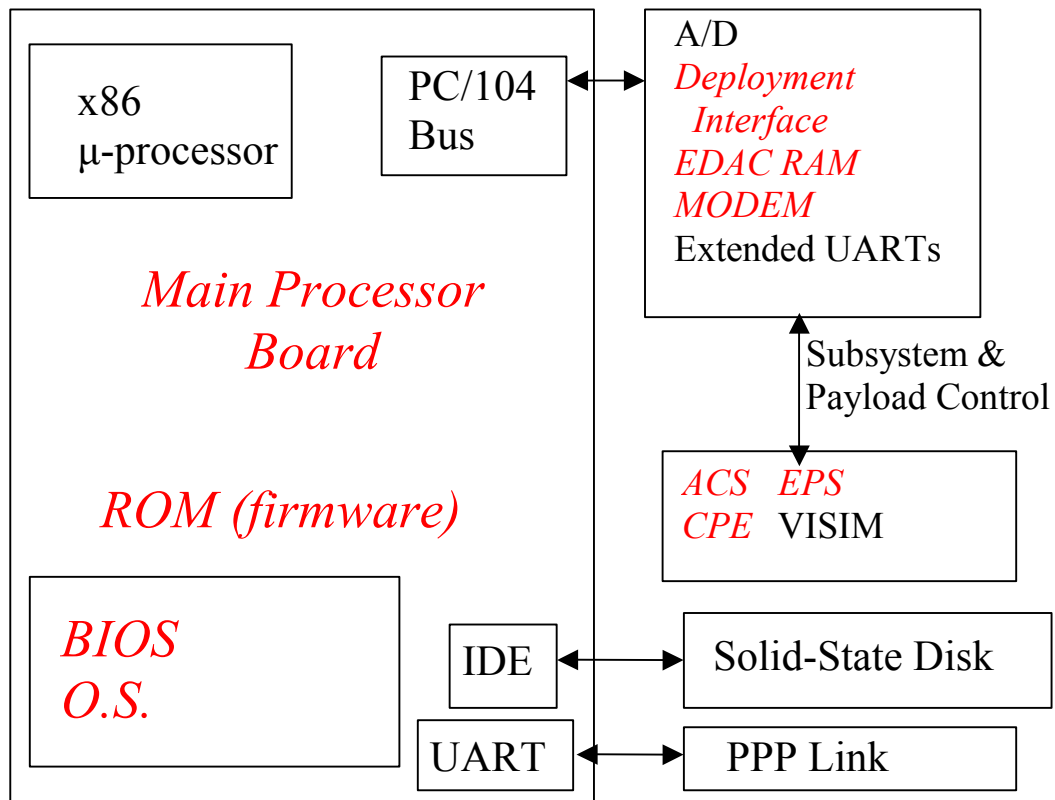

Figure 13. C&DH (NPSAT1 Design Overview).

Basic input/output system, or BIOS, is built-in software that determines what a computer can do without accessing programs from a disk. The NPSAT1 Operating System (O.S.) is Linux. The IDE, or Integrated Drive Electronics is a method of connecting hard drives. The EDAC RAM (Error Detection and Correction Random Access Memory) is discussed in the next section.

## **1. Limits**

One of the largest issues of concern in the C&DH subsystem would be the handling of the image data created by the digital camera. Processing such complex and high-volume data not only requires a capable processor, but also combined with the low power requirements throughout the spacecraft make the image processing a formidable challenge.

Due to the unavoidable experiencing of single-event upsets (SEU) in the space environment, the design approach has made a preliminary determination that EDAC memory would be necessary. EDAC can be designed with different capabilities, and the NPSAT1 EDAC is being designed to correct single bit errors only. If there are occurrences of multi-bit errors, the processor board will reset. An additional limitation is that the C&DH processor and other components will not be radiation hard.

## **2. Tradeoffs**

Issues of power consumption, processor speeds, and memory types and capabilities have all appeared in discussions regarding tradeoffs in this particular area. The number of possible combinations and variations in this software-driven subsystem are endless. However, it has been determined that due to the unavailability of a COTS solution to the EDAC system memory, the C&DH processor board will be designed in-house.

## **3. Software**

Effective and reliable software is critical to both meeting timeliness objectives in a satellite design project and accomplishing mission success of the spacecraft on orbit. The following is a brief overview of NPSAT1's C&DH software ideas, including reasons and objectives for its uniqueness, as published in a recent NPS Research Newsletter:

The Naval Postgraduate School is developing NPSAT1 to incorporate commercial standards in a processor architecture that potentially improves reliability of software and decreases development time. The software part of any space system is arguably the least reliable and most prone to cause schedule delays, and thus increases the cost of the program. A likely cause for delays and unreliability is the uniqueness of the space flight hardware as a computing platform. Because of this hardware uniqueness, software cannot reliably be tested until hardware becomes available on which to run and debug software drivers, routines, and control algorithms. The problem becomes more readily apparent as more autonomy is required of the spacecraft that in turn demands a more sophisticated operating system. One solution is to use current standards that are widely accepted in industry. This affords the use of commercial-off-the-shelf (COTS) products. The goal of the NPSAT1 small satellite is to demonstrate a command and data handling (C&DH) subsystem which is compatible with a common desktop PC along with a POSIX-compliant operating system, namely Linux. The Linux operating system is a robust, multitasking operating system with a rich environment for the software developer. Combining the PC hardware with the Linux operating system software offers the means by which software development carried out on desktop PCs is fully compatible with the target flight hardware. At NPS, this means officer students can work on software algorithms without the need to code at the hardware level (NPS Research, 2001).

THIS PAGE INTENTIONALLY LEFT BLANK

### **III. PAYLOADS**

NPSAT1 has a design that will incorporate a variety of small payloads. Major sponsors will provide some payloads, and some are going to be designed and built locally. Other options may include the use of individual COTS components to make up a unit, or possibly be an entire unit that is ready for installation in its unaltered COTS state. No matter what their backing or source of origination, all payloads will be combined to function within the overall NPSAT1 design architecture.

#### **A. COHERENT ELECTROMAGNETIC RADIO TOMOGRAPHY**

The Naval Research Laboratory (NRL) in Washington, DC is a major sponsor of projects such as NPSAT1. On this project, the NRL is sponsoring two payloads in support of their ongoing research into the realm of ionospheric propagation effects on satellite to ground/ground to satellite communications. The payloads are known as Coherent Electromagnetic Radio Tomography (CERTO) and a Langmuir Probe. These payloads, experiments, and measurements are not new, but the flexibility and variations in information collected due to different orbital environments and different orbital elements experienced by each and every satellite can contribute to the overall success of this series of experiments.

##### **1. Description**

CERTO is a multi-beacon transmitter whose purpose is to assist in the monitoring and measurement of atmospheric scintillations on radio wave propagation. As many as three different frequencies can be used, but NPSAT1 will carry only a two-frequency transmitter for the purposes of this experiment. The transmissions, at 150.012 and 400.032 MHz will be continuous wave and phase coherent. Receiving stations can be either ground based or space based, and the locations of which will only be relevant for

duty cycling the transmitter, as the CERTO beacon will not be able to be transmitting continuously due to power constraints.

## **2. Reason for Inclusion**

The potential benefits of developing a substantial database and model for electron content in the ionosphere have significant applications within the Department of Defense (DoD), as well as in commercial applications. Specifically for the DoD, where the use of radar, navigation, surveillance, and communications rely heavily on space assets, a working knowledge of the effects of scintillations on system performance is essential. Even more beneficial would be the ability to predict those instances where the scintillations would be too intense to be able to avoid, and a critical communications element, for example, could be delayed or changed in such a way that the scintillation period would not directly affect its outcome. An accurate model or method of predicting any type of atmospheric interference would also be very beneficial for those periods when navigation is critical and having only space-based systems available as a reference.

A decision aid currently exists with similarities to what experiments such as CERTO can provide. According to the Air Force Research Laboratory, “Scintillation Network Decision Aid is a computer program that predicts communication satellite outages above the equator that are caused by naturally-occurring disruptions in the ionosphere” (SCINDA, 1998). The NRL views the SCINDA as more of a regional tool, and hopes to ultimately create a decision support aid that will be global in scope. The CERTO discoveries would lead to a more extensive data set of Total Electron Content (TEC) in the ionosphere for use in modeling and forecasting tools and applications.

## **3. Ground Stations**

The ground station portion of the overall attempt to collect information relating to ionospheric scintillations is somewhat autonomous, and not hardware-intensive. A ground station consists of simply an antenna and a desktop personal computer. The

software already exists to manage the incoming data, which ultimately gets forwarded to the NRL for further analysis and applications. NPS will likely become a CERTO beacon ground station, which will allow the project participants to see how this resident payload operates, reinforcing the objectives planned by installing such a payload.

The Naval Research Laboratory has several ground stations for CERTO and other similar space experiments. The portability and relatively low cost for establishing and maintaining these stations make it nearly impossible to predict exact locations that the NPSAT1 spacecraft will have in its view once it reaches orbit in approximately five years. There will be orbital reasons for only being able to see certain ground stations, and there will also be power and duty cycle considerations when the ground site locations are in fact known. However, these will be relatively simple to program into NPSAT1's C&DH software package.

## **B. LANGMUIR PROBE**

In close relation to the CERTO experiment will be the inclusion of a Langmuir Probe experiment. Also sponsored by the NRL, it will contribute to modeling ionospheric TEC from data taken at spacecraft altitude.

### **1. Description**

The probe is a deployable "antenna" that collects readings from the environment as the spacecraft travels through it. There are no transmissions as in the case of CERTO, but rather just a collection of electronic data that will be stored in NPSAT1 until the spacecraft comes in view of the NPS ground station and does a download. The Langmuir Probe data will likely be packaged with the rest of the payload data, as well as any telemetry and subsystem health data that is scheduled for downloading. The orientation of the antenna will be such that it is flying normal to the flight plane, exposing as much of the surface area of the antenna to the bombardment of electrons in the flight plane.

## **2. Reason for Inclusion**

Collection of ion content at orbit altitude can result in data that can be correlated with the CERTO data. Studies can ultimately lead to better location of ion concentrations by comparing not only the beacon transmissions that travel through the ionosphere to the ground, but also the ion content at orbit altitude of NPSAT1 and other spacecraft carrying similar ion-measuring payloads. If there are several spacecraft carrying Langmuir Probes and/or CERTO transmitters, and if these different spacecraft are at significantly different altitudes, a variety of measurements would be taken and correlation may provide extremely important data about the ion content and the effects these concentrations could have on DoD communications and detection systems.

## **C. VISIBLE (WAVELENGTH) IMAGER (VISIM)**

The payload that will be nearly 100% COTS technology will be the digital camera payload. Not only will having a camera on NPSAT1 make it possible to see an occasional snapshot from the spacecraft's perspective, but it will also make it possible for some software and hardware experiments to be conducted as a proof of concept.

### **1. Description**

This will be a COTS selection, with no space applications or hardening involved. A PC/104 computer board will be dedicated to the camera operations. The camera will be fixed in position, pointing out the bottom of the spacecraft, most likely pointing right through the payload adapter ring that is expected to be located there. The camera and lens will have no adjustable focus or aiming abilities, so the quality of the photos will rely on the pointing accuracy of the spacecraft combined with the spacecraft's flight stability. Below are some of the digital camera's performance specifications, assuming a 450 km orbit altitude:

- Resolution: ~70 m
- Exposure Speed: 1 msec
- Pixel Size: 7.4 X 7.4 microns
- Pixels per image: 652 X 492
- Image area: 1570 km<sup>2</sup>
- Raw image size: 320 kbytes

## **2. Reason for Inclusion**

The cliché “a picture is worth a thousand words” is a primary reason for including such a payload on the NPSAT1 project. The applications of having a camera on the spacecraft are not limited to actual photographs. Since processing images is much more complex from a software standpoint, this will be a true test of the abilities of such a small-scale satellite project design team.

There are a myriad of opportunities for applying the data and images recovered from the camera payload. Not only will the ground station personnel be looking forward to recovering the first images captured by NPSAT1, but also they will be curious to see if the photos are accurate with what the program was designed to do.

A bit more external to the design project team, some of the applications of having an imager in orbit can extend to local areas and communities. Some thoughts have arisen that would make the NPSAT1 images available to the public for educational purposes, as well as making some sort of interactive application (i.e. web based) which would enable select outside agencies, such as local elementary schools, connect to the site and request certain images be taken. The opportunities really are endless, especially when the product is something as common and understandable as a photograph.

## **3. Capabilities**

The operation of the camera hardware itself will be software-intensive. The complexities included in the image-taking process are compounded when it is time to

push and process the raw data into a usable form. Some of the areas of concern will be related to available power and communications access to the ground station, as well as available memory. To alleviate part of the communications access problem (not enough download time for high volumes of imagery data), the idea being pursued is to compress images and download highly-compressed preview images on one pass of the satellite, then allow the ground personnel to select which images, if any, are to be fully downloaded on another available pass. This approach seems to make sense, but will need to consider both the time available for communications as well as the available memory. The decision will be not only be how many complete images to be downloaded, but also determining storage priority or quality acceptance in case the spacecraft will not be within view of the ground station for an extended period of time before it can off load the memory-intensive images. Examples of different levels of JPEG (Joint Photographic Experts Group) compression (file size followed by compression ration) are shown in Figure 14, and Figure 15 shows some of the imaging hardware.

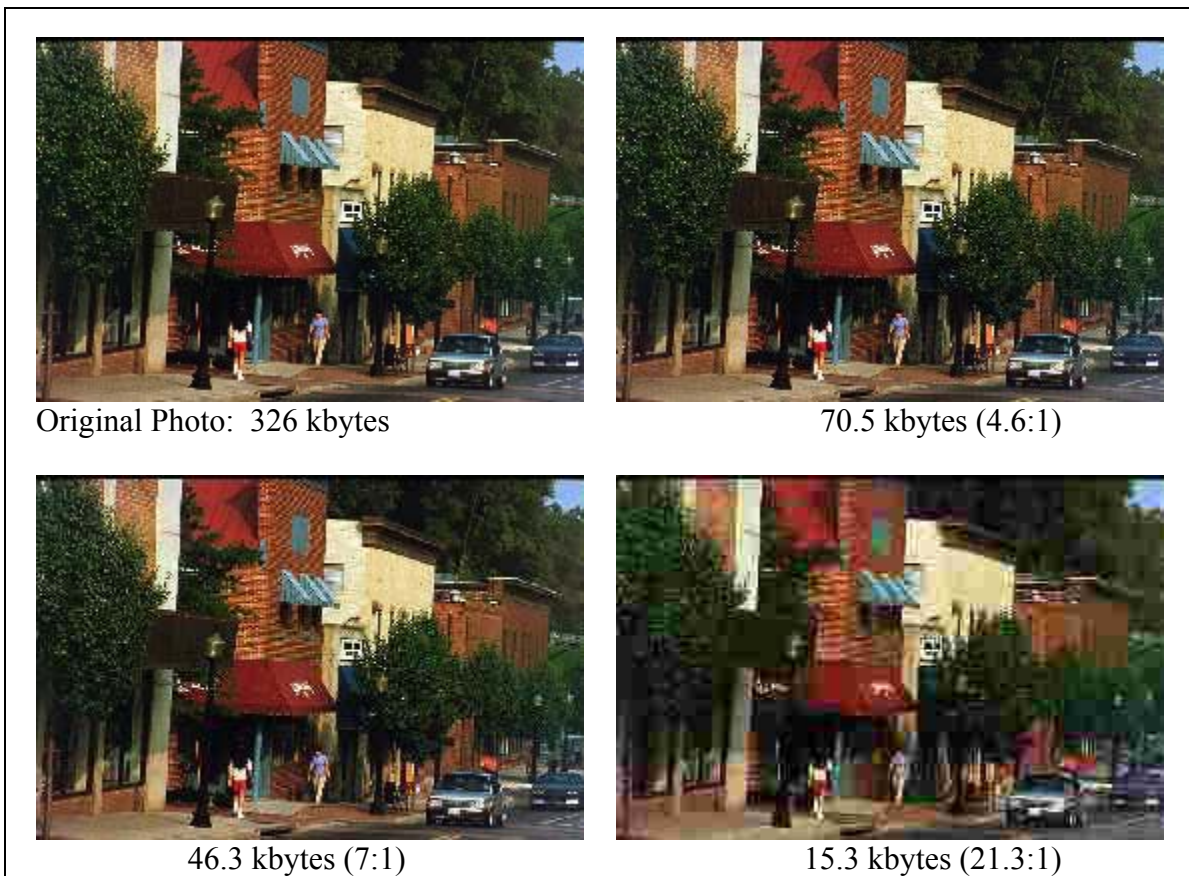

Figure 14. Examples of Compression (After JPEG Compression Example).

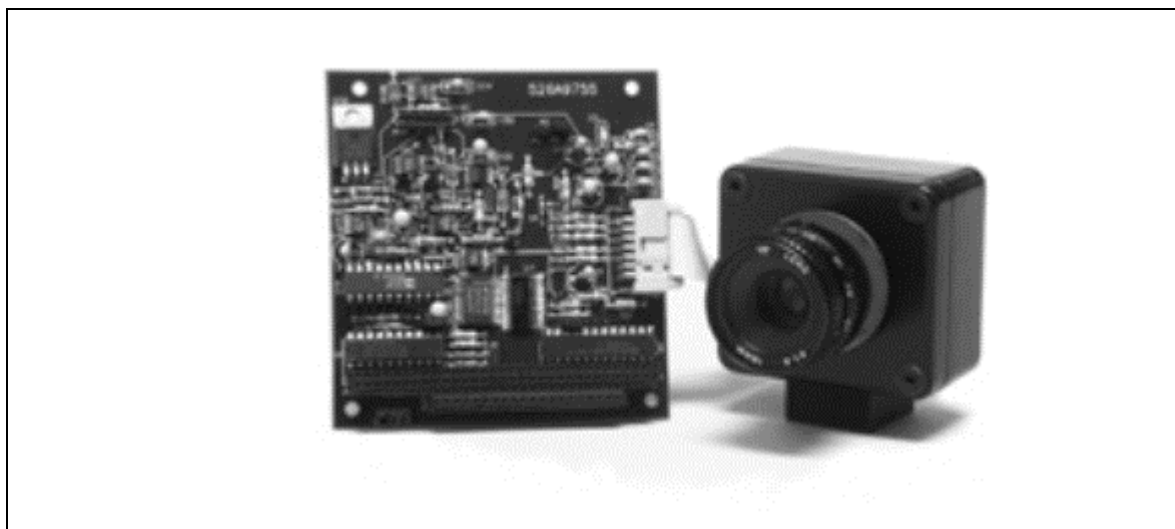

Figure 15. Digital Camera and PC/104 Board (NPSAT1 Design Overview).

## **D. MICRO ELECTRO-MECHANICAL SYSTEMS (MEMS) EXPERIMENT**

The MEMS experiment will use COTS components for a spacecraft technology demonstration. MEMS devices can serve a myriad of applications, and not only in the space industry. The NPSAT1 team, however, realized that MEMS might be a valuable addition to their attempt at making advances in areas not extremely well tested in space.

### **1. Description**

The devices to be used with NPSAT1 will be three rate sensors arranged orthogonally for a triaxial sensor, to assist in the attitude control of the spacecraft, an added benefit especially during the initial acquisition/startup phase. The information collected by these MEMS devices will be fed into the attitude control algorithm to assist in establishing and maintaining a stable spacecraft. A thesis on MEMS for small satellites has been recently completed at NPS which included testing of a MEMS rate sensor similar to those targeted flight (Okano, 2001).

### **2. Reason for Inclusion**

The purposes of incorporating MEMS devices into the NPSAT1 project are twofold. First, the benefit of having more rate sensing equipment in addition to the Attitude Control Subsystem's equipment (i.e. magnetometers) should make the ACS more effective and efficient at accomplishing its mission. Second, using MEMS technology in space will be an experiment in using a non-hardened rate sensor in space, the history of which is not known. The MEMS rate sensors can be used periodically throughout the life of NPSAT1, not just during the acquisition/startup phase, which will provide additional tests of their operation in space. (NPS Research, 2001)

## **E. CONFIGURABLE PROCESSOR EXPERIMENT**

One experiment on NPSAT1 that has its design and origination from within the confines of the Monterey campus is the Configurable Processor Experiment (CPE). This will reside as a card on the C&DH PC/104 bus.

### **1. Description**

Thesis work is currently underway on this experimental payload at NPS. According to Lashomb, the CPE “is an extension of the Triple Modular Redundant (TMR) processor system (three microprocessors and their associated voting logic). The intent is to implement it using a single Xilinx FPGA (XCV-800) mounted on a PC/104 interface card that includes necessary ROM and RAM for programming the Xilinx chip and uploading experimental programs. The Xilinx chip would be programmed to emulate the necessary hardware of the processors, voting logic, FIFOs, and latches” (Lashomb, 2001). Refer to Figure 16 for the CPE block diagram.

### **2. Reason for Inclusion**

In theory, this configuration would provide additional processing capacity to supplement the C&DH PC/104, resulting in a more efficient operation of internal processing requirements. It may be possible for the CPE to be tasked with a certain portion of payload data processing, such as receiving input from the Langmuir Probe and processing it so that it can be easily packaged and transmitted when necessary. Depending on the capabilities of the CPE, a more intense and complex task could be sent its way, such as being responsible for all image compression and processing requirements. These attempts at a division of effort within the processing components of the spacecraft appear to be conceptually ideal, but further analysis of the components and

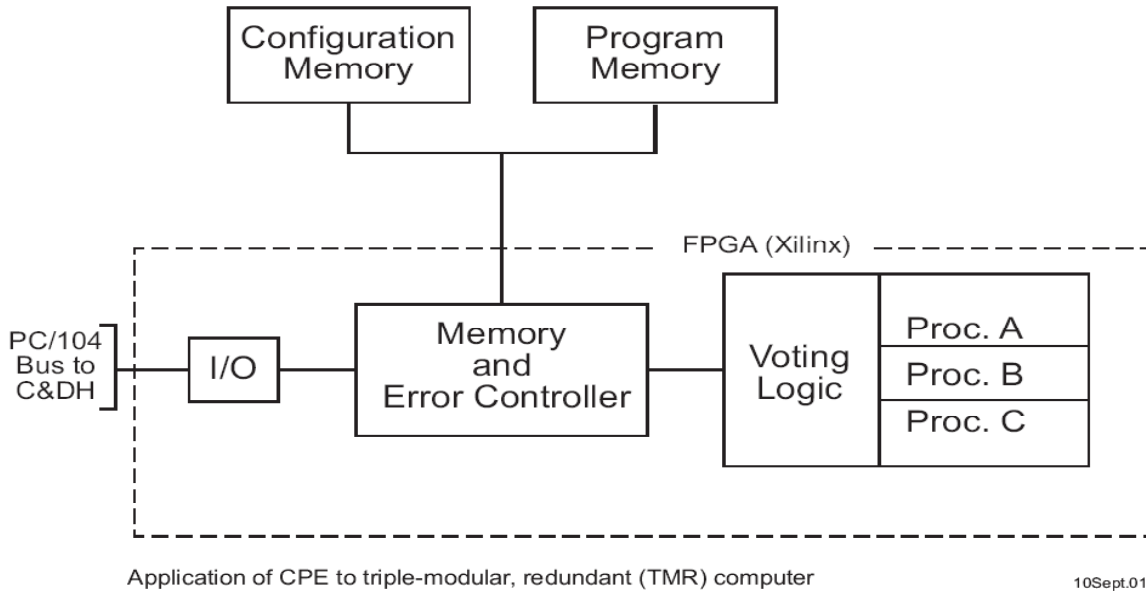

Figure 16. CPE Block Diagram

the workloads they can accept will ultimately fall back to the issue of available power and other resources necessary to complete the processes. Lashomb also adds, “If successfully implemented, such a TMR design would be re-configurable for upgrade and/or in-flight repair of damaged logic. There are many questions in such an implementation and its reaction to a radiation environment such as how the soft-logic would respond to Single Event Upsets.... whether a SEU would simply cause a fault in the ‘Logic’ or a fault in the program which structures the logic and what is the best way to mitigate either case” (Lashomb, 2001).

## **IV. LAUNCH ELEMENT**

### **A. DEPARTMENT OF DEFENSE SPACE TEST PROGRAM OVERVIEW**

Designing a spacecraft is no small task, but neither is it the only major item for consideration when beginning a program with intentions of making it into orbit. One of the largest factors, especially one of the largest cost factors in most situations, is obtaining a launch vehicle to transport the satellite into its orbit.

Without benefits and assistance provided by larger programs and organizations, institutions like the NPS most likely would not be able to successfully get programs such as PANSAT and NPSAT1 off the ground, literally. It is due to organizations such as the Department of Defense's Space Test Program (STP) and associated Space Experiments Review Board (SERB) that smaller institutions and research labs associated with the DoD are able to get their projects into space.

The STP, headquartered at Kirtland Air Force Base in Albuquerque, NM has a primary objective of getting those experiments listed on the SERB priority list a flight to space. The SERB prioritizes applicants from across the DoD according to military relevance (60%), quality of experiment (20%), and service priority (20%). Ultimately, the list of experiments produced by the SERB is delivered to the STP organization for further planning, eventually resulting in a flight of the experiment into space. According to the STP web site,

Once an experiment makes the priority list there are three general ways which it can gain space flight. Mission design and planning effort is initiated to study the most cost effective means for space flight, attempting to match up flight opportunities with specific experiments. For experiments with unique orbital requirements that can best be met by free-flying spacecraft, Space Test Program (STP) contracts for spacecraft development, experiment integration, and launch service. STP also flies experiments as secondary payloads (piggybacks) on spacecraft of various agencies, including NASA and DOD, and various countries, including Russia and France. The third way in which STP

gains space flight for SERB ranked experiments is through a collaboration with NASA to fly experiments on the Space Shuttle which are either attached to the payload bay carriers or housed in the crew cabin. These experiments can be located in the payload bay and either retained within the bay or ejected for orbital flight. Other experiments are flown in the mid-deck area of the Space Shuttle crew cabin. (STP, 2001)

The Space Test Program outlines an eight-step process that is typically followed by organizations hoping to use the STP for gaining access to space. This step-by-step process is listed below:

- **Step 1: Getting A Sponsor:** DOD experiments normally originate in the Service (Army, Air Force, Navy, NASA) laboratories or in research institutions (colleges, universities, think tanks, etc) but are in no way limited to these institutions. Every experiment must be sponsored by a DOD agency.
- **Step 2: Submitting a Request:** Each experiment's sponsoring agency submits a DD Form 1721 through organizational channels to SAF/AQS. This form is first used by the DOD-SERB to evaluate the experiments and prioritize them.
- **Step 3: Ranking Process:** Each experiment is assigned a ranking on the DOD-SERB experiment priority list at the DOD-SERB meeting. Rankings are based on briefings given by the experiment's sponsoring agencies to a panel of government representatives. The panel consists of representatives from the Air Force, Navy, Army, and other DOD agencies. Experiments are ranked based on the panel's assessment of its DOD relevance. In addition, the panel considers other factors including experiment quality and service priorities.
- **Step 4: Identification of Flight Opportunities:** The identification of space flight opportunities begins with the development of an STP mission model for upcoming years. This model takes into account spacecraft and booster budget constraints and the number and type of prioritized experiments. Opportunities to fly as secondary payload on non-STP spacecraft are also included in the overall mission model.
- **Step 5: Space flight Assignment:** Once a space flight opportunity has been identified, all STP experiments are reviewed to determine which are compatible with the opportunity. Experiment payload questionnaire are sent to each experiment compatible with the mission. The objective of the questionnaire is to provide more detailed technical information than was provided by the DD form 1721. The information in the responses to these questionnaires, together with the STP priority list and the space flight opportunities are then studied to determine which experiments are best included in the mission.

- **Step 6: Acquisition Process:** Getting the mission approved by SAF/AQS and assigned a space flight is only the first step toward space flight. The remainder of the process depends on the complexity of the mission.

Secondary missions, such as small payloads on a host vehicle and Get-Away-Specials (GAS) on the Shuttle usually only involve a memorandum of agreement and the transfer of funds from STP to the program office.

Primary missions require that STP procure a spacecraft and booster or launch service. In these cases, STP must go through the DOD procurement process, which includes receiving approval for the acquisition strategy plan and conducting source selection activities through contract award. Experimenters and their sponsors are involved in two ways: Laying the groundwork for mission approval (i.e. for the expenditure of STP funding for the mission) and through briefings and meetings in support of source selection and contract award.

- **Step 7: Integration Process:** Once an experiment has either a host vehicle or a spacecraft and booster, detailed integration design and analyses are done by both the experimenter and the integration contractor. The result of this effort is an interface control document that defines the technical interface requirements which the experimenter must meet to be compatible with its spacecraft. Changes to the experiment design/requirements after this point require contractual changes and will increase the cost of the mission.
- **Step 8: Launch and On-Orbit Operations:** Once the experiment is integrated to a spacecraft, it is launched and on-orbit operations begin. Experiment data is collected, formatted and transmitted to the experimenter. One year of on-orbit operations is provided by STP. (STP, 2001)

## **B. LAUNCH VEHICLE OPTIONS**

NPSAT1 is close to being accepted and manifested for a Delta IV launch vehicle in the latter months of 2005 or early 2006. The following sections will discuss certain launch vehicle options that were considered during the NPSAT1 design process, culminating with NPSAT1's means of accessing space, the Delta IV.

### **1. Space Shuttle**

Referred to as the Space Transportation System (STS) by NASA, the overall Space Shuttle program is highlighted by arguably the most technologically magnificent machine built by humankind (the orbiter), as well as being an unbelievable workhorse in

launching and repairing spacecraft and delivering other cargo to space, such as is the case in the International Space Station. This reusable spacecraft was the launch vehicle for PANSAT, so NPS has knowledge of and appreciation for the Space Transportation System.

***a. Performance Capability***

Complements of its two solid rocket boosters and the orbiter's main engines the Space Shuttle is capable of lifting upwards of 55,000 lbs into a 110 nautical mile orbit at 28.5 degrees inclination (STS, 2000).

***b. Availability***

The real issue is how easy or difficult would it be to get on an STS mission in the next 4-6 years, especially with so many missions scheduled for the International Space Station over the next several years. Even though the DoD stresses the importance of the STP and the SERB, it is rarely a priority of NASA to concern themselves with this type of experimental payload, especially with the extreme importance of succeeding with this manned spacecraft and its high-profile missions. The Space Shuttle was always in the back of the design team's minds, especially since it was the launch access provided to PANSAT. However, most of the focus was toward other launch vehicles, expecting that the most likely choice would be one of the expendable varieties. In addition, NPSAT1 needs to be inserted into an orbit of at least 550 km altitude, whereas the International Space Station and the Space Shuttle missions that support it reside at a lower altitude of approximately 350-390 km.

***c. Limitations and Concerns***

The primary area of concern when discussing the possibility of using the Space Shuttle as a potential launch vehicle lay in the issue of safety. Due to this being a manned space flight, there are extreme measures of safety and reliability that must be built into any satellite designed for launch on the Space Shuttle. The design team had lessons learned regarding all these critical issues, and did not prefer to relive the issues encountered regarding PANSAT's launch vehicle.

## **2. Taurus**

A private company known as Orbital Sciences Corporation designed a launch vehicle of much smaller proportions and technical complexities: the Taurus launch vehicle system. It is intended for use for payloads much smaller than typical Space Shuttle payloads, but the goal of this launch program was to provide a means of relatively low cost and highly reliable access to space.

### ***a. Performance Capability***

According to the Taurus User's Guide, the vehicle is well suited for getting a wide variety of missions into Low Earth Orbit (LEO) over various altitudes. It also possesses the capability to transport payloads to Geosynchronous Transfer Orbit (GTO). NPSAT1 would provide no problem for the capacity and orbit limits of the Taurus vehicle, as it can easily inject up to 455 kg (1000 lbs) to a LEO of approximately 600 km in altitude at inclinations between 28.5 and 40 degrees from the Eastern Range, and inclinations of 55 to 120 degrees from the Western Range (Taurus, 1999). NPSAT1's nominal weight of 82 kg (181 lbs) would provide little challenge for this or any other launch vehicle of average capacity and performance.

### ***b. Availability***

Orbital prides itself on being able to meet relatively short-notice requests for launch services (several months), even though that is rarely necessary to execute in the space and satellite launching business. According to their users guide,

The Taurus system can operate from a large variety of launch facilities and geographic locations. The system is compatible with, and will typically operate from, existing U.S. Government ranges at Vandenberg Air Force Base (VAFB), Cape Canaveral Air Station (CCAS), and Wallops Flight Facility (WFF). While most commercial missions do not require the rapid response capabilities of the original Taurus program, the same design features that allow the Taurus system to meet these requirements are used to streamline vehicle integration and launch operations for all Taurus missions. (Taurus, 1999)

*c. Limitations and Concerns*

There are no significant limitations or concerns regarding the NPSAT1 design project and the potential for it using a Taurus launch vehicle for its transportation into orbit.

**3. Pegasus**

Another product of the Orbital Sciences Corporation is known as Pegasus. This launch vehicle, different from many other launch vehicles, is carried to a high altitude by a large jet aircraft, then deployed and fires its own rockets in order to reach the desired orbit inclination and elevation.

*a. Performance Capability*

The Pegasus platform is quite impressive in its class. According to its user's guide, "over the past ten years, the 'winged rocket' known as Pegasus has proven to be the most successful in its class, placing 70 satellites in orbit with 29 launches." (Pegasus, 2000) Since this is a smaller launch vehicle, its payload and altitude capabilities are a bit less than other launch vehicles discussed. For instance, according to the user's guide, the maximum capacity a Pegasus can get to an altitude of 600 km is 350 kg (770 lbs). (Pegasus, 2000)

*b. Availability*

The portability and air-launch technique allows for the Pegasus launch vehicle to have flexibility that is unknown to the traditional launch pad rockets. It can be launched from virtually anywhere in the world, meeting a large variety of extremely unique launch requirements.

*c. Limitations and Concerns*

There are no significant limitations or concerns regarding the NPSAT1 design project and the potential for it using a Pegasus launch vehicle for its transportation into orbit.

**4. Delta IV**

Complements of the DoD Space Test Program, and the obvious efforts of the NPSAT1 design team, NPSAT1 will be launched on a Delta IV (medium) launch vehicle, hopefully prior to calendar year 2006. A new challenge to this Boeing Delta IV launch will be the incorporation of the Evolved Expendable Launch Vehicle (EELV) Secondary Payload Adapter (ESPA) ring. This ring will provide the capability for the launch vehicle to carry not only a primary payload of significant size and importance, but also up to six smaller, secondary payloads. These secondary payloads will be mounted to the ESPA ring, and be pointing out, perpendicular to the direction of flight of the launch vehicle.

*a. Performance Capability*

The launch that NPSAT1 has been scheduled for will have several unique characteristics, all of which are well within the capabilities of a Delta IV launch vehicle. As the manifest now stands, the primary payload will be launched into a geosynchronous transfer orbit (GTO), while all of the secondary payloads will be launched into LEO, each with similar characteristics, with variations based on the timing of each spacecraft's release from the ESPA ring. The Delta IV Payload Planner's Guide reports that it can put almost 9,000 lbs into a 19,323 nautical mile GTO (Delta IV, 1999). These numbers were used to calculate how much each of the secondary payloads could weigh, and the final tally for all secondary payloads was no more than 400 lbs each.

***b. Availability***

Based on current scheduling information provided to NPS by the personnel in charge of the STP, the schedule is for NPSAT1 to be launched as a secondary payload in October 2005. The timeframe for this availability date was largely the result of financial considerations, since the U.S. Air Force was responsible for acquiring the launch vehicle from Boeing. Without any further delays and unavoidable circumstances, this will be the launch date used for all future planning and coordination requirements for NPSAT1, its neighboring secondary payloads, and the primary payload for this launch.

***c. Limitations and Concerns***

Use of the ESPA ring for this launch will not have historical precedence, so there will be a bit of added concern regarding the entire launch process. The physical limitations for NPSAT1 to fall within will not be problematic. There are concerns, however, that since this launch will be sending what amounts to at least six different spacecraft, each with a number of additional payloads and experiments of significant value, there is the potential for unwanted interference among all the different sizes, shapes, and types of hardware present within the Delta IV fairing.

The layout of the payloads being integrated into this launch has brought out a few understandable concerns among the participating agencies and sponsors of the payloads. The primary payload sponsor will have obvious concerns that any or all of the secondary payloads could potentially cause some problems that could render the primary payload useless (i.e. a secondary payload not ejecting from the ESPA ring, therefore remaining as a part of the primary payload “structure”). This is not hard to comprehend, as the primary payload carries with it not only a much more significant payload and operational mission, but also a price tag that far outweighs those of the secondary payloads.

The ESPA ring layout brings with it some additional integration challenges, especially due to the close proximity of all the secondary payload satellites. Even though each secondary payload is aware of its physical limits and the volume it is

allowed, a primary concern lies in the potential for a misfiring ejection mechanism, or even a premature deployment of a part of the spacecraft (e.g., a deploying solar panel or antenna). The consequences of a premature deployment, especially if the fairing is still on the launch vehicle, could be detrimental to the entire payload assembly, primary and secondary, as well as to the launch vehicle itself. Not only do all the spacecraft designers need to concern themselves with what could go wrong with their satellites, but also they may need to be concerned, at least in small part, about what some of the potential hazards may be in regards to the other satellites within the fairing.

THIS PAGE INTENTIONALLY LEFT BLANK

## V. POST-LAUNCH OPERATIONS

One method of ensuring the operations of a spacecraft and its payloads are adequately prepared and designed is to develop an overall operations plan. Wertz and Larson refer to this as a Mission Operations Plan (MOP). Developing this MOP can be done according to the following step-by-step process:

Step 1: Identify the mission concept, supporting architecture, and key performance requirements.

Step 2: Determine the scope of functions needed for mission operations.

Step 3: Identify ways to accomplish functions and whether capability exists or must be developed.

Step 4: Do trades for items identified in the previous step.

Step 5: Develop operational scenarios and flight techniques.

Step 6: Develop timelines for each scenario.

Step 7: Determine the resources needed for each step of each scenario.

Step 8: Develop data flow diagrams.

Step 9: Characterize responsibilities of each team.

Step 10: Assess mission utility, complexity, and operations cost drivers.

Step 11: Identify derived requirements.

Step 12: Generate a technology development plan.

Step 13: Iterate and document. (Wertz and Larson, 1999)

Some of the benefits of using such a step-by-step process could be avoiding unnecessary redundancies, identifying critical areas of concern, minimizing cost

overruns, and many other useful applications. One area or step that is of extreme importance in any project of this scope is the “iterate and document” step. No matter where it falls on the list of steps, an effort to iterate, document, and reiterate is crucial.

The NPSAT1 design team has settled on three generic modes of ACS operations once the satellite is released from the launch vehicle/ESPA ring (ACS0, ACS1, and ACS2). The five modes of communications are 0, 1, 2, 3, and 4. The separate phase labels and descriptions are based upon a combination of ACS and communications requirements. Figure 17 is a state diagram that displays the various modes of operation, with ACS transition state changes forcing state changes of communications modes. There are five communications states in the diagram, each of which having several different scenarios that may force its specific operation.

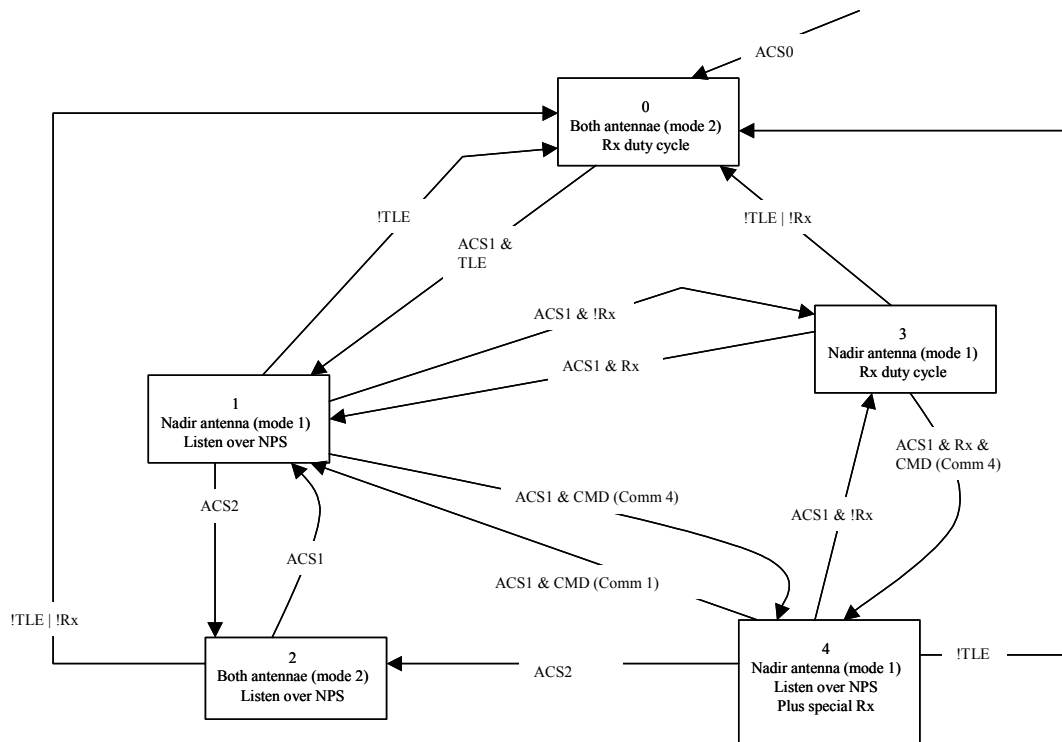

**LEGEND**

- ! Not (inverts the condition)
- & And (logical and)
- | Or (logical or)
- TLE Two Line Elements are valid
- Rx Communications from NPS within 2 days (estimate)
- ACSx ACS mode number
- CMD NPS Command issued

Rx duty cycle:  
 50% → 0% power margin  
 25% → 8% power margin

!Rx occurs when there has been 2 days (estimate) elapsed time since the spacecraft has communicated with NPS. After each communication with NPS the Rx timer is reset. In addition each state change resets the Rx timer.

**ATTITUDE CONTROL SYSTEM**

- ACS0: Acquisition Mode/Startup  
TLEs are irrelevant  
No experiments are running
- ACS1: Normal Mode  
TLEs are assumed valid
- ACS2: Recovery/Pointing Error Mode  
TLEs are assumed valid  
No CERTO/Langmuir Probe

Figure 17. C&DH-controlled States of Communications

## **A. COMMUNICATIONS STATE: 0**

This first phase will be the most critical phase of NPSAT1's life on orbit. If there are no communications with the NPS ground station, the odds of NPSAT1 being able to carry out any of its designed missions are minute at best. The ACS0 transition state will be initiated upon separation from the launch vehicle, directing NPSAT1 to its default communications state, communications state 0. This default state will also be initiated by either an ACS reset or a spacecraft reset.

### **1. Phase Description**

The ACS during this phase will be in what has been labeled the acquisition or startup mode (ACS0). During this phase, both the communications antennas will be in a receiving state, operating to the maximum capacity that can be supported by the batteries and the remainder of the EPS. While in this receiving state, the two antennas will be duty-cycled simultaneously, controlled by a pre-determined time schedule that will provide for maximum reception of NPS commands without draining the batteries below acceptable levels. The specific time schedule is yet to be determined, but will be set according to a ratio of listening to not listening (i.e. 20 seconds listen, 60 seconds off, repeat).

### **2. Priorities**

The priorities are going to be establishing a communications link with the NPS ground station and obtaining initial acquisition of spacecraft attitude. Until a link can be closed and the necessary ephemeris data can be uploaded NPSAT1 will be reliant on its initial attitude control for acquisition. That is, nulling rotational rates of the spacecraft and attempting some pointing control.

Other events that can be carried out during this phase may include images being taken shortly after separation from the ESPA ring, catching some photographs of the

launch vehicle from the perspective of the recently-released NPSAT1 secondary payload. Also, the deployment of both the CERTO antenna and the Langmuir probe could be conducted prior to much of the ACS autonomous operations.

### **3. Tradeoffs**

The limiting factor is that there is no pointing stability in the ACS in the acquisition phase (Communications state 0, ACS0). Depending on the charge on the batteries at launch time, the only option may be to power up the ACS, deploy the CERTO antenna and Langmuir Probe (to assist in stabilizing the spacecraft), and do nothing further until communications are established with the NPS ground station. The power issue could be somewhat relieved even if the spacecraft makes several orbits prior to establishing the link with NPS, as long as the solar cells are effectively charging the batteries without complications that require ground station intervention.

## **B. COMMUNICATIONS STATE: 1**

Communications state 1 will be in effect once the acquisition and startup processes are successfully completed, and the ACS is in control of NPSAT1.

### **1. Phase Description**

The ACS in this phase will be considered in the normal mode (ACS1), and the Two-Line Elements (TLEs) are assumed valid. Obviously, this mode will be the one where the design team hopes to see NPSAT1 during the majority of its mission life. Normal ACS operations will be able to maintain stable pointing of the spacecraft, only requiring the nadir-pointing antenna to operate whenever the NPS ground station is within communications range. The C&DH subsystem will be responsible for orchestrating the various payload operations, ensuring the status of the spacecraft remains healthy.

## **2. Priorities**

As long as NPSAT1 is reporting a healthy and fully operational status to the ground station, each of the payloads will be dependent upon established commands that will determine duty cycles, activation times, and other elements of each payload's established and pre-determined operating profiles. Payload operations will be primarily based on available power. Also, certain payloads may be paired to operate simultaneously (i.e. CERTO and Langmuir Probe), whereas other payloads will only be operational based on NPSAT1 location and field of view. Examples of this latter condition include the requirement for the digital camera's view to be over landmass rather than ocean area.

## **3. Tradeoffs**

The assumption here is that since the spacecraft is operating in a normal mode, all payloads and subsystems have effectively checked out as being operational. Circumstances may arise that require scheduling changes based on the need for a critical download of data, along with a potential critical upload of command data from the ground station. In such a case, there may be the need for the batteries to be at sufficient capacity for the critical data exchange, and payloads may have to sacrifice their originally scheduled operating time for the good of the spacecraft and its mission. Ultimately, the tradeoff issues will fall back to a combination of power usage and communications availability limitations, and will be controlled by a scheduling mechanism within the C&DH subsystem.

## **4. Transition from Communications State: 1**

No system is perfect, and there is a need for contingency plans in case there are any malfunctions that cause errors within this phase. Figure 17 shows four instances

where NPSAT1 would shift from Communications state 1 to different communications states (Communications state 0, 2, 3, or 4), and the following list gives examples of causes:

- TLEs invalid (!TLE) (e.g., out-of-date)
- ACS assumed to be operating normally, but loss of communications with NPS (ACS1 & !Rx)
- Recovery/Pointing Error observed (ACS2)

#### **C. COMMUNICATIONS STATE: 2**

This is one of three identified contingency states, and is a result of an ACS2 (Recovery/Pointing error) mode. During this phase, both antennas will be in a listening state while NPSAT1 is in view of the NPS ground station. Once a link is established and ACS1 (normal) is reestablished, NPSAT1 will transition to Communications state 1. If there are no successful communications, or the TLEs are invalid, NPSAT1 will transition to the default phase, Communications state 0.

#### **D. COMMUNICATIONS STATE: 3**

This contingency state results from a loss of communications with the ground station. In this circumstance, the nadir antenna will listen and will be duty cycled to regain a communications link. If communications are reestablished, NPSAT1 will return to Communications state 1. If not, or if the TLEs are invalid, NPSAT1 will return to Communications state 0. An additional option for transitioning from this state is when both ACS1 and communications are normal, but the ground station has commanded NPSAT1 to transition to Communications state 4.

**E. COMMUNICATIONS STATE: 4**

This contingency is the result of a ground station command (Comm 4) directing the transition from another state. It is characterized by the nadir antenna listening while over NPS as in a normal pass within view, but with an additional allotment of receive time to allow for any special communications requirements. The transition from Communications state 4 can occur to any of the other Communications states, depending on the circumstances present. For instance, if there is a loss of communications with the ground station, NPSAT1 will transition to Communications state 3. Another circumstance could occur if there is a detected pointing error, in which case NPSAT1 would transition to Communications state 2. If the special communications of Communications state 4 are complete, and if the ACS is in normal mode, the NPS ground station can direct the transition back to Communications state 1 with a specific command (Comm 1).

**F. GENERAL TIMELINE OF ON-ORBIT OPERATIONS**

A snapshot of on-orbit operations and estimated times associated with the different phases is depicted in Figure 18.

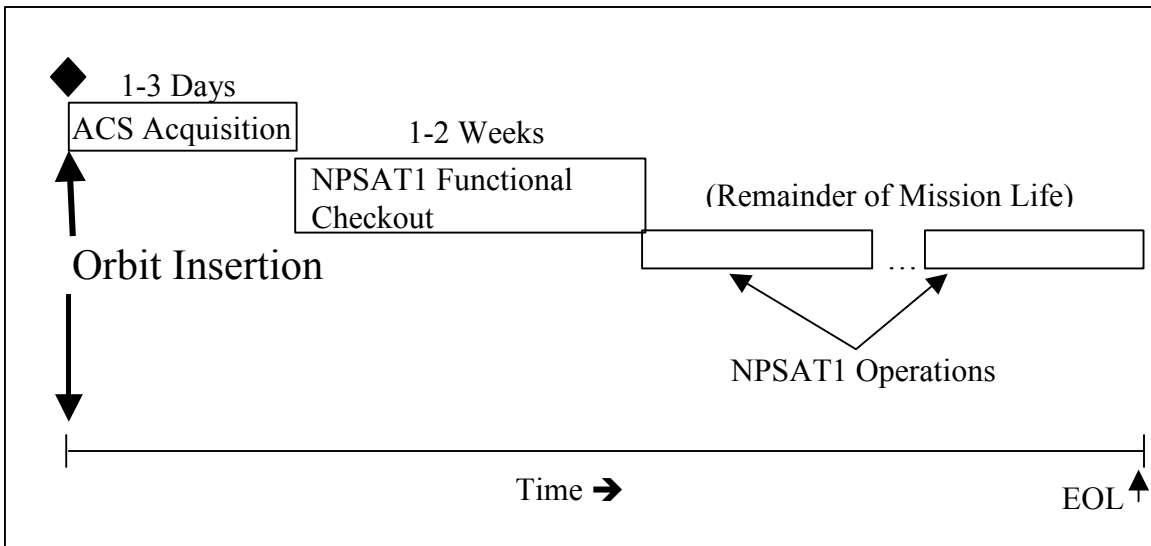

Figure 18. General Timeline of NPSAT1 On-orbit Operations

The portion of Figure 18 showing NPSAT1 Operations will require detailed scheduling and planning of payload operations. Not only will there be duty cycling required due to the minimal power budget, but also certain payloads (such as the camera and the CERTO beacon) should only be operated over certain parts of the Earth. In the case of the CERTO beacon, it will only be activated when there is a receiving station within view of NPSAT1. The camera's scheduling will be directed to take images over land areas only, with ocean images being of little value. Another activity that will be strictly location-dependent is the T&C communication exchange with the NPS ground station. Obviously, this data link can only be established when NPSAT1 and NPS are within view of each other.

THIS PAGE INTENTIONALLY LEFT BLANK

## **VI. CONCLUSIONS AND RECOMMENDATIONS**

By the time NPSAT1 is flight ready, it will have gone through numerous changes in content and design. It will also have been subjected to a wide barrage of ideas, with origination sources ranging from first-year postgraduate school students to tenured professors. Many of these ideas will have contributed to the overall design of the project, but whether each one is fully incorporated or not is a whole other issue. This chapter will discuss some areas of concern in major topic areas, as well as provide a review of some other issues mentioned earlier in the document.

### **A. LAUNCH VEHICLE**

The issue of launch vehicle selection or choice is not a matter that is within the realm of responsibilities of the NPS satellite design program. Launch vehicle selection is really more accurately stated as “payload acceptance” to an already known and most likely acquired launch vehicle. The issue of concern is whether or not research laboratories and educational institutions can present their projects in such a manner so as to be included on the priority lists created by the STP SERB.

Since the NPSAT1 design team was successful in presenting this particular experiment as viable to the STP SERB, NPSAT1 made the priority list for the year 2000. Establishing NPSAT1 as an acceptable payload experiment within the Space Test Program is the sole requirement for NPS when attempting to arrange a launch. After that, the focus of the design team is directed to ensuring the project is adaptable and flexible enough to fit on any of the several likely launch vehicle options.

NPSAT1 and its design team looks forward to being integrated on the ESPA ring, ultimately to be launched as one of several secondary payloads on a Boeing Delta IV. NPSAT1 should maintain its direction in preparing for the Delta IV ESPA launch in late

2005, but also be aware of potential launch vehicle changes, and the associated adaptations that could be required.

## **B. INITIAL ON-ORBIT OPERATIONS**

All recommendations regarding the operation of the NPSAT1 satellite within the initial phases after its successful separation from the ESPA ring are dependent on the battery status. The batteries will be trickle charged to capacity up until approximately five days prior to the launch, with no charging ability after that until the spacecraft is on orbit. The batteries should maintain the majority of their charge for several weeks, as they have a self-discharge rate of approximately three to five percent per month. The steps to follow for initial operations should be as follows:

- Notification of successful separation from ESPA ring via microswitch closing
- EPS startup initiated by closing of microswitch
- Power up the C&DH subsystem
- Initialize and power up digital camera and processor
- C&DH subsystem commands images to be taken of launch vehicle
- C&DH subsystem commands deployment of CERTO antenna and Langmuir probe
- Power up the ACS
- ACS0 (Acquisition/Startup mode) initiated
- T&C antennas duty-cycled accordingly to operate in receiving state to establish contact with NPS ground station (Communications state 0)

Upon successful completion of a communications link and an exchange of essential orbital ephemeris data, confirmation that NPSAT1 is orbiting with known performance parameters (Z axis within 10 degrees of nadir, X axis within 10 degrees of velocity vector, rates  $\leq 0.66$  degrees per second with reference to orbit frame for all axes) should be reestablished and adequately verified prior to operating any additional payloads.

### C. PAYLOAD PRIORITY USAGE

Operations of the various NPSAT1 payloads will need to be one of the most flexible design issues included in the overall mission design project. The infinite number of possible options and combinations of separate payload operations force the design team to be able to manipulate the operations on a daily basis if required. According to the NPSAT1 Experiment Requirements Document, Figure 19 provides a power profile for one day of operations based on initial estimates, assuming a worst-case orbit and solar panel illumination (ERD, 2001)

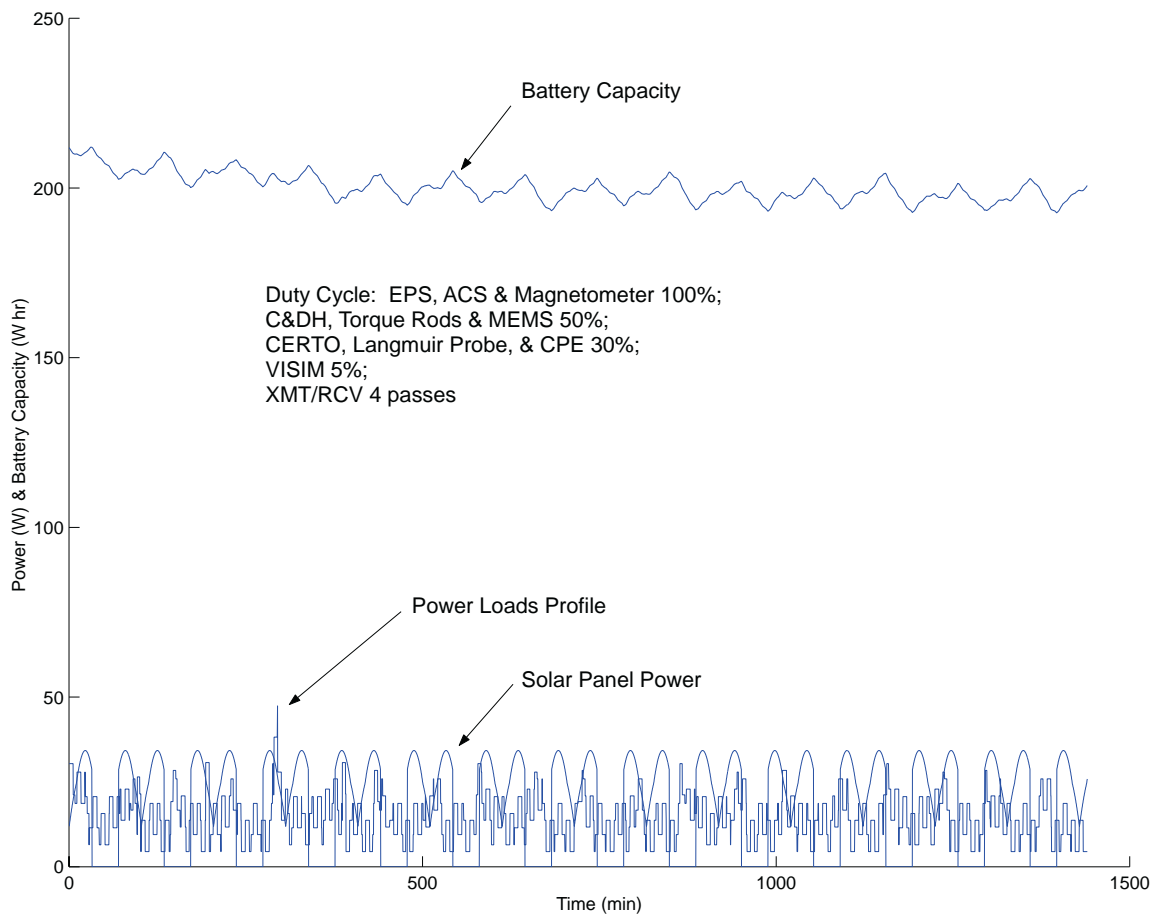

Figure 19. Power Duty Cycles

As review and iteration become more and more commonplace as the lifetime of this design project proceeds, the above values for payload usage can be used as

benchmarks for the eventual planning of payload operations. Changes are common, especially with the possible introduction of new or different payloads. Also, the possibility for increases or decreases in available power exists.

Even with the most well-thought and comprehensive design plan and mission operations plan, feedback from the spacecraft on orbit will dictate the necessary changes, if any, to the operations plan. Changes may be favorable (e.g., better solar cell efficiency than originally predicted), leading to more payload use and experiment options rehearsed. However, the opposite may also be true, with unfortunate circumstances leading to changes that severely limit NPSAT1 and its payloads to minimal operations. Whatever the case, operational flexibility and reliable communications are the key to successful mission operations.

#### **D. BENEFITS OF NPSAT1 TO NPS**

The ability and opportunity for an institution such as NPS to participate in such a program provide one-of-a-kind educational opportunities to the service officers who attend. The training and experience gained by participating in a hands-on project such as this are really the core of the Space Systems curriculum. Not many of the participating students will have follow-on tours that will involve building spacecraft, yet the experiences gained by all involved, faculty included, are a part of the overall learning process that is an objective of institutions such as NPS.

In addition to the direct benefits to those service officers involved with the design project, the publicity that can be generated by this type of program can be of extreme benefit to the NPS. In one critical area, having another successful design project already making it through the STP SERB process lends credence to the NPS small satellite design program, helping to smooth the way for future attempts by NPS to get ranked on the STP SERB. The track record of NPS in this category has been proven with both PANSAT and NPSAT1.

## **E. FOLLOW-ON WORK**

The satellite design and construction process by itself is a long, drawn out evolution. Then, adding the launch vehicle integration and related requirements into the process add up to a project that encompasses several years. Since this is definitely the case with NPSAT1, and since the design is still in its relatively early stages, there remains much work that needs to be done in order to successfully complete this project.

Much of the initial work has been done, but due to the requirements and limitations on such a project, there will be more work to do up until launch time. Each individual subsystem for NPSAT1 can benefit from a detailed performance analysis, in addition to a thorough analysis of potential tradeoffs and alternative designs. Many of the subsystem areas have a direct impact on other subsystems and overall spacecraft performance, so any in-depth studies on one subsystem will most likely need to continue to include analysis on the effects on other parts of the spacecraft.

The Electrical Power Subsystem has been a focus from the beginning of the design project, due to the accepted fact that the available power for this project was going to be minimal. This subsystem probably ranks as equally crucial with the Attitude Control Subsystem, and both of these subsystems would greatly benefit from in-depth study and performance analysis. There is already a team committed to the ACS and its design, and another team could be created to address the EPS and its high priority performance requirements.

Another subsystem that could greatly benefit from additional hours of dedicated work is the Command and Data Handling Subsystem. Since the majority of the software being used in NPSAT1 is going to be designed and created within the confines of the NPS campus, there is an opportunity for student project and thesis work that could greatly benefit the design team and its efforts. Software engineering is going to be responsible for the “brain” of NPSAT1, an area that can not be assumed to be irrelevant or otherwise lesser in value than any other portion of the project. Again, the requirement for work in this area will include impacts on all other subsystem and payload components in the NPSAT1 spacecraft.

The areas of payloads and their related operations have only been lightly addressed in this thesis, as the purpose here was to provide a more general overview of the issues being faced by the NPSAT1 design team. There are opportunities for further review at several layers regarding the NPSAT1 payloads, to include the following: overall on-orbit payload operations; individual payload operations; and individual, case-by-case, or contingency payload operation plans that could possibly be faced during the lifetime of NPSAT1.

## **F. CONCLUSION**

NPSAT1 is well on its way toward becoming a successful small satellite design project and orbiter. The Preliminary Design Review has been conducted already in 2001, and further milestones will be accomplished in just a few short months (such as the Critical Design Review). The efforts of the faculty and staff in ensuring all scheduling milestones are met are continuous, and will ultimately be the reason for this project's successful integration into a launch configuration and effective orbit operations.

## APPENDIX. LINK BUDGET SPREADSHEET

		Ground	Spacecraft			1	slant range -km	2367	800 km maximum altitude
Gmd transmitter frequency-GHz	1.76757	2.2073	S/C transmitter frequency-GHz			2	f	BER	1.00E-05
Gmd transmitter power-W	2	1	S/C transmitter power-W			3	Pt	Eb/No-dB	9.6 (SMAD pg 562, same for BPSK)
Gmd antenna diameter-m	3	0.043	S/C antenna diameter-m			4	D	Rb-kbps	100
Gmd antenna pointing error-deg	2	10	S/C antenna pointing error-deg			5		km for BPSK	1 (SMAD pg 562, =2 for QPSK)
Gmd ant feed trans efficiency-%	70	70	S/C ant feed trans efficiency-%			6	Nt	Rs-kbps	100
Gmd ant feed rcv efficiency-%	70	70	S/C ant feed rcv efficiency-%			7	Nr	ro	1.5 (Sklar & SMAD)
Gmd receiver noise temp-K	164	419	S/C receiver noise temp-K			8	T	C/No req'd-dB	59.6 Eb/No+10*log(Rb)
Gmd receiver bandwidth-MHz	0.25	0.25	S/C receiver bandwidth-MHz			9	BW	BW signal-MHz	0.25 (1+ro)*Rs
dc pwr trans efficiency-%	8.9	8.3				10		Req'd C/N-dB	5.6205999 C/No-10log(BW)
Total dc per req'd-W	22.47	12.05				11		Margin-dB	3
COMMDATA LINK		UPLINK	DOWNLINK			12		Design to C/N-dB	8.6205999
frequency-GHz	1.76757	2.2073				13	f(line2)		
wave length-m	0.17	0.14				14	L=c/f (line44/line 13)		c-m/s
						15			
Gmd ant beam width (O )-deg	8.00	180.00	S/C ant beam width (O )-deg			16	Obw=21/Df see SMAD pg 571		Average Power Available-W
Gmd transmitter power-dBW	3.01	0.00	S/C transmitter power-dBW			17	Pt (line3)-dB		Altitude-km
Gmd ant feed loss-dB	-1.55	-1.55	S/C ant feed loss-dB			18	Nfct line6/100-dB		Beta-deg
Gmd antenna gain-dB	34.89	-0.05	S/C antenna gain-dB			19	G=(pi*DL)^2-dB		0
Gmd antenna EIRP-dBW	36.35	-1.60	S/C antenna EIRP-dBW			20	EIRP=sum(17,18,19)		30
Gmd ant pointing error loss-dB	-3.52	-0.92	S/C ant pointing error loss-dB			21	Noet=20log[1/(1+2*Oe/Obw)]		60
						22			90
path loss-dB	-164.87	-166.80	path loss-dB			23	Npr=20log(L/(4*pi*r))		Slant Range
atmospheric/rain loss-dB	-1.20	-1.20	atmospheric/rain loss-dB			24	Nrm from Agrawal, Fig 7.6 @E1=15		10 deg El
polarization loss-dB	-0.25	-0.25	polarization loss-dB			25	Nz given		1,160 km
link margin-dB	0.00	0.00	link margin-dB			26	Nmg (Included in requirement above)		2,367 km
						27			
S/C ant beam width (O )-deg	276.30	3.17	Gmd ant beam width ( )-deg			28	Obw=21/Df see SMAD pg 571		
S/C feed loss-deg	-1.55	-1.55	Gmd feed loss-deg			29	Nfct line 7/100-dB		
S/C antenna gain-dB	-1.98	36.82	Gmd antenna gain-dB			30	G=(pi*DL)^2-dB		
S/C antenna pointing error-dB	-0.61	-7.09	Gmd antenna pointing error-dB			31	Noer=20log[1/(1+2*Oe/Obw)]		
S/C receiver/carrier power-dB	-137.63	-142.59	Gmd receiver/carrier power-dB			32	Pr=sum(20,21,23,26,29,31)		
S/C noise power density-dB	-202.38	-206.45	Gmd noise power density-dB			33	No=k*T-dB Bltz's crst k		1.38E-23 J/K
S/C receiver bandwidth-dB	53.98	53.98	Gmd receiver bandwidth-dB			34	BW-dB		
S/C receiver noise power-dB	-148.40	-152.47	Gmd receiver noise power-dB			35	Pr=lin33+line34		
						36			
						37	PFD=(line20)/(4*pi*r^2)		
						38	PFD/4KHz=line37-10log(4000)		* Limited to approx -148 dB
						39			exceptions for fixed services
S/C rec'd carrier noise ratio-dB	10.76781	9.88739	Gmd rec'd carrier noise ratio-dB			40	C/N=line32-line35		
	C/N	11.93387	9.74404			41	10^(line40/10)		
	Relay System C/N-dB	7.29503				42	D41*E41/(D41+E41)-dB		

THIS PAGE INTENTIONALLY LEFT BLANK

## LIST OF REFERENCES

- AA4831 [<http://intranet.nps.navy.mil/NPSat>]. December 2000.
- Delta IV Payload Planner's Guide, The Boeing Company, October 1999.
- ERD for NPSAT1. August 2001.
- ESPA Planner's Guide, June 2001.
- Holemans, W. [<http://www.nanosat.usu.edu/presentations/lb4/slide001.html>]. July 1999.
- Interview between Dr. P. Bernhardt, Naval Research Laboratory, Washington, DC, and the author, 19 March 2001.
- JPEG Compression Example. [<http://www.cs.sfu.ca/fas-info/cs/CC/365/li/material/cgi-bin/whichjpeg.cgi>]. September 2001.
- Johns Hopkins APL Technical Digest, Volume 22, Number 2, 2001.
- Lashomb, Peter. Electronic correspondence between LT Peter Lashomb, USN, Naval Postgraduate School, Monterey, CA, and the author, September 2001.
- Okano, E. S., Microelectromechanical Systems for Small Satellite Applications, Master's Thesis, Naval Postgraduate School, Monterey, CA, June 2001.
- MXCOM Incorporated, "Increasing Data Throughput in Radio Telemetry Systems," [[http://www.mxcom.com/app\\_notes/apIDTRTSr1.pdf](http://www.mxcom.com/app_notes/apIDTRTSr1.pdf)], September 2001.
- NPS Research, Volume 11, Number 2, June 2001.
- NPSAT ADCS Interim Review, August 2001.
- NPSAT1 Design Overview. [<http://www.sp.nps.navy.mil/npsat1/technical/NPSAT1.htm>]. August 2001.
- "PANSAT." [<http://www.sp.nps.navy.mil/pansat/>]. July 2001.
- Pegasus User's Guide, August 2000.
- SCINDA. [<http://quark.plk.af.mil/factsheets/scinda.html>]. July 1998.
- SHELS User's Guide, December 1999.

STP. [<http://www.te.plk.af.mil//dodserb/dodserb.html>]. July 2001.

STS. [[http://science.ksc.nasa.gov/shuttle/technology/sts-newsref/sts\\_overview.html#sts\\_overview](http://science.ksc.nasa.gov/shuttle/technology/sts-newsref/sts_overview.html#sts_overview)]. August 2000.

Taurus User's Guide, September 1999.

Wertz, J. R. and Larson, W. J., *Space Mission Analysis and Design*, 3d ed., Microcosm Press, 1999.

## INITIAL DISTRIBUTION LIST

1. Defense Technical Information Center  
Fort Belvoir, Virginia
  
2. Dudley Knox Library  
Naval Postgraduate School  
Monterey, California
  
3. Professor Rudy Panholzer  
Naval Postgraduate School  
Monterey, California
  
4. Dan Sakoda  
Naval Postgraduate School  
Monterey, California