

NASA SP-5013

TECHNOLOGY UTILIZATION NOTES

Technology Utilization Division

DISTRIBUTION STATEMENT A
Approved for Public Release
Distribution Unlimited

57895

PRECISION TOOLING TECHNIQUES

Reproduced From
Best Available Copy

From
GEORGE C. MARSHALL SPACE FLIGHT CENTER
Huntsville, Alabama

PROPERTY OF:
AMPTIAC LIBRARY



20011116 119

NATIONAL AERONAUTICS AND SPACE ADMINISTRATION

NASA SP-5013

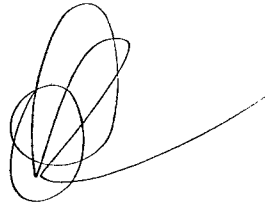

TECHNOLOGY UTILIZATION NOTES

Technology Utilization Division

PRECISION
TOOLING
TECHNIQUES

NATIONAL AERONAUTICS AND SPACE ADMINISTRATION

WASHINGTON, D. C.

OCTOBER 1964

NOTICE

This document was prepared under the sponsorship of the National Aeronautics and Space Administration. Neither the United States Government, nor NASA, nor any person acting on behalf of NASA:

A. Makes any warranty or representation, express or implied, with respect to the accuracy, completeness, or usefulness of the information contained in this document, or that the use of any information, apparatus, method, or process disclosed in this document may not infringe privately owned rights; or

B. Assumes any liabilities with respect to the use of, or for damages resulting from the use of, any information, apparatus, method, or process disclosed in this document.

FOREWORD

THE Administrator of the National Aeronautics and Space Administration has established a technology utilization program for "the rapid dissemination of information . . . on technological developments . . . which appear to be useful for general industrial application." From a variety of sources, including NASA Research Centers and NASA contractors, space-related technology is collected and screened; and that which has potential industrial use is made generally available. Information from the nation's space program is thus made available to American industry, including the latest developments in materials, processes, products, techniques, management systems, and analytical and design procedures.

The tooling concepts described herein are a direct result of techniques developed within the Astrionics Laboratory of the George C. Marshall Space Flight Center.

**The Director, Technology Utilization Division
National Aeronautics and Space Administration**



CONTENTS

	PAGE
PRECISE LATERAL-ADJUSTMENT INSTRUMENT SUPPORT	1
HARD-ANODIZED ALUMINUM LAPS.....	3
MACHINE FOR ^{All} <u>LAPPING</u> SPOT FACES.....	5
INSTRUMENT FOR DETERMINING SQUARENESS OR PER- PENDICULARITY.....	9
TOOL FOR MEASURING DEVIATION FROM PARALLEL... .	13
CHAMFERING SMALL HOLES.....	15
UNIVERSAL ^{All} <u>LATHE</u> AND JIG BORE FIXTURE HOLDER... .	19
PRECISION LATHE MOUNTING RING.....	23

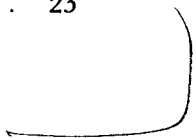

end

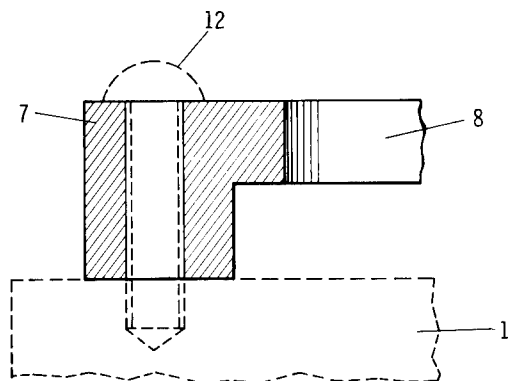
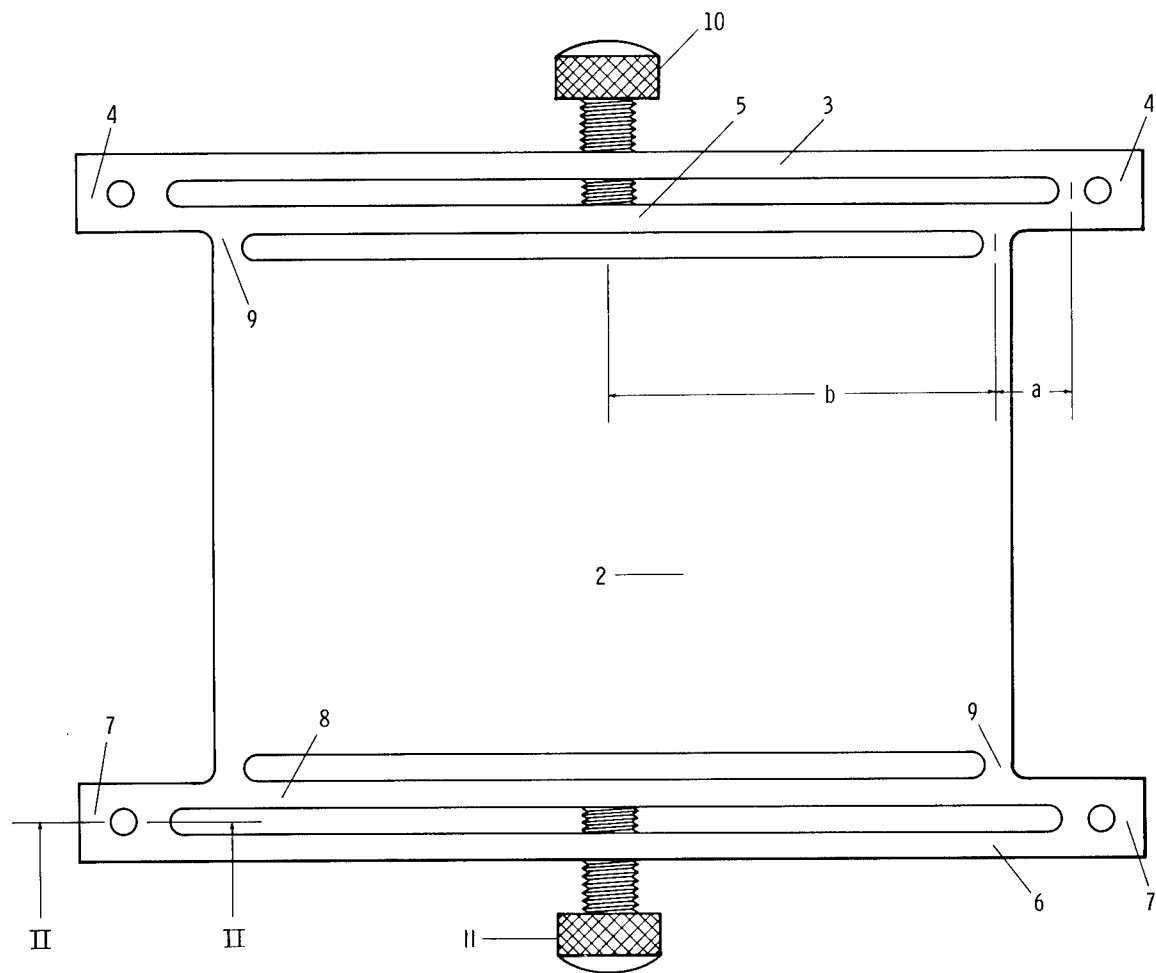

FIGURE 1.—Instrument support with precise lateral adjustment.

Precise Lateral-Adjustment Instrument Support

Rugged Support Permits Precision Centering of Instruments Without Unwanted Movement

Innovation by WILHELM ANGELE and DONELSON B. HORTON

Marshall Space Flight Center encountered a problem in precisely centering instruments such as Indi-Ron and Talyrond to determine or measure the roundness of an object. Vernier devices used in making lateral adjustments of the instrument were found unsatisfactory because of looseness and backlash.

The development of an instrument support that is both versatile and reliable solved the problem. The support can be attached to any measuring or gaging apparatus for checking roundness, and allows lateral adjustment to within 1-millionth of an inch. Its rugged construction and unique mode of operation completely eliminate undesired movement of the instrument.

The adjustable instrument support can be made of any metal that has a high modulus of elasticity. In the assembly shown in figure 1, the support is a steel plate. Beams 3, 5, 6 and 8, and instrument support body 2 are free of base 1 to eliminate friction. Beam pairs 3, 5 and 6, 8 were milled on opposite sides of the body to permit precise movement of the body by rotation of the adjusting screws 10 and 11.

The beam links, 4 and 7, also serve as pads for mounting the instrument support to the base. The beams are connected to the instrument support body by necks 9, which are spaced inwardly a predetermined distance from the ends of the beams, so that the relationship of lever arms a and b is a predetermined ratio. In figure 1 the ratio a/b is 1 to 20.

Assuming adjustment screw 10 has a pitch of 50 threads per inch, one complete revolution of the screw would cause beams 3 and 5 to separate 1-fiftieth of an inch (0.02 inch). Each beam would account for half the separation, or 0.01 inch. Because beam 5 is connected by neck 9 to the body, a movement of .010 inch toward the center of the body would be reduced by the ratio a/b or 1 to 20. The resulting movement of 1-twentieth of 0.01 inch, or 0.0005 inch, would hold true only if the opposite side of the plate were free to move. Because the opposite side is fixed to the base by pins 12, the resistance of the elastic beams 6 and 8 further reduces movement by a factor of 2. Thus, the movement of the body has been reduced to 0.00025 inch.

The calibration of adjustment screw 10 so that it can be turned accurately in increments of 1.5 degrees, or about $\frac{1}{250}$ of a turn, would result in a final body motion of 0.000001 inch (1-millionth of an inch).

If adjusting screw 11 had 45 or 55 threads per inch, movement of the body could be refined by a factor of 10 simply by rotating screws 10 and 11 against each other to the same degree. This would result in a motion of 0.0000001 inch (one 10-millionths of an inch).

Figure 2 shows a variation on the device, with an instrument support of $\frac{3}{4}$ -inch, anodized 7075 aluminum. The use of a single flexible beam

increases movement by a factor of 2. The increase can be overcome somewhat by increasing the number of threads on the adjusting screws to 64 per inch.

The use of two lateral adjusting plates of this type, at right angles to each other and attached to a leveling base plate, makes it possible to cen-

ter an Indi-Ron, Talyrond or similar device more precisely than by any other method known.

The rigidity of the device makes it suitable for use with machine tools to provide ultrafine movement of a part to be machined, thus giving it a valuable application in addition to the purpose for which it was designed.

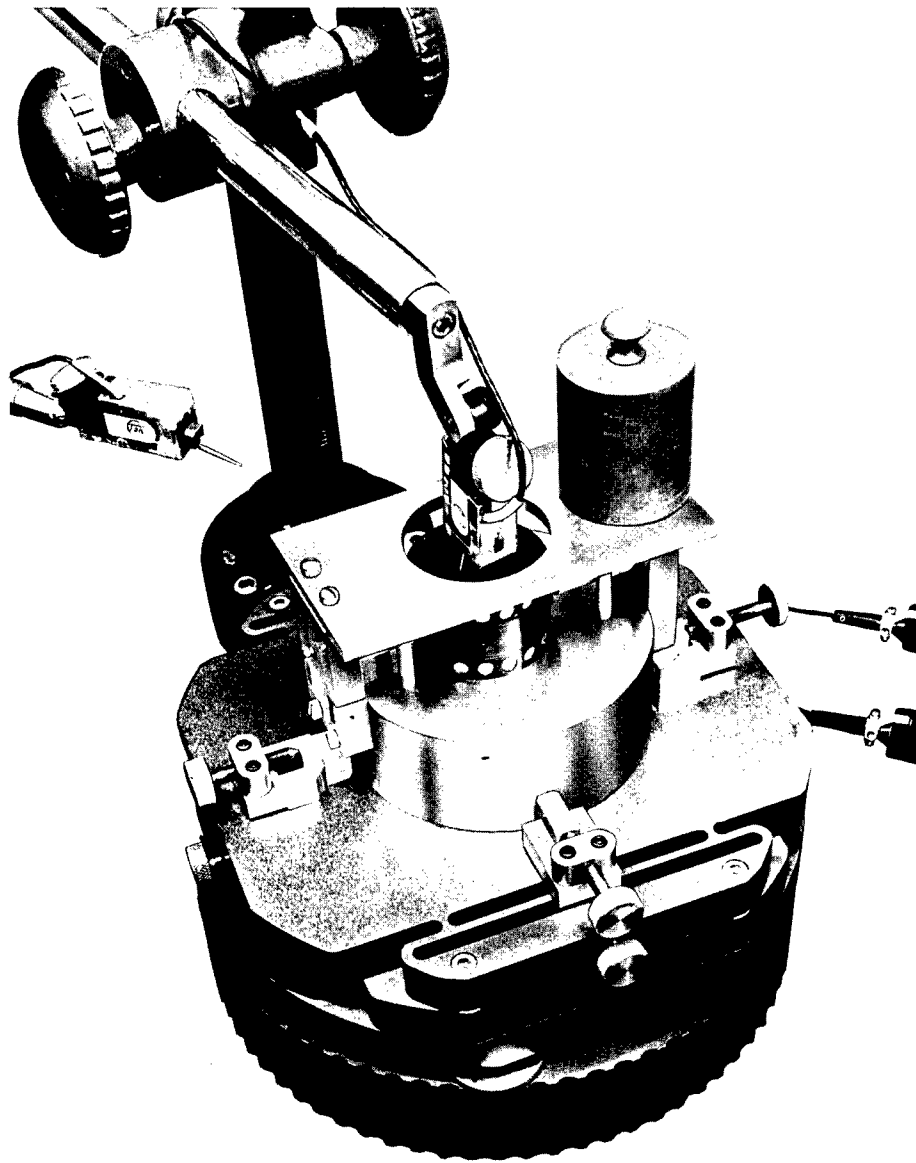

FIGURE 2.—A complete centering device consisting of two single-beam supports at right angles attached to leveling base.

Hard-Anodized Aluminum Laps

Surface Laps of Hard-Anodized Aluminum Prove Best for Preparing Highly Polished Surfaces

Innovation by WILLIAM J. ABERNATHY

The development and manufacture of air bearings for space vehicle guidance and control devices has forced industry to search out better aids in machining and lapping precision parts to ever-decreasing tolerances. In its air-bearing development work, the Astrionics Laboratory found a superior lapping material for preparing highly polished surfaces.

Experience showed that hard-anodized aluminum laps with a surface hardness equal to that of a sapphire lasted longer before reworking and produced better surface finishes than laps made of such materials as cast iron (mee-

hanite), brass or granite. The older lapping materials wore faster and thus required more frequent checking and reworking than hard-anodized aluminum.

Figures 3 and 4 show laps made of aluminum that was machined to the desired size and shape, stress relieved, lapped and then hard-anodized. The hard-anodized surface was then lapped with diamond and aluminum compounds to an ultrafine surface finish of 2 microinches. The final surface was highly wear-resistant and gave extended service without reconditioning. Parts being lapped showed no tendency to gall or

FIGURE 3.—Hard-anodized aluminum flat and cylinder bore laps.

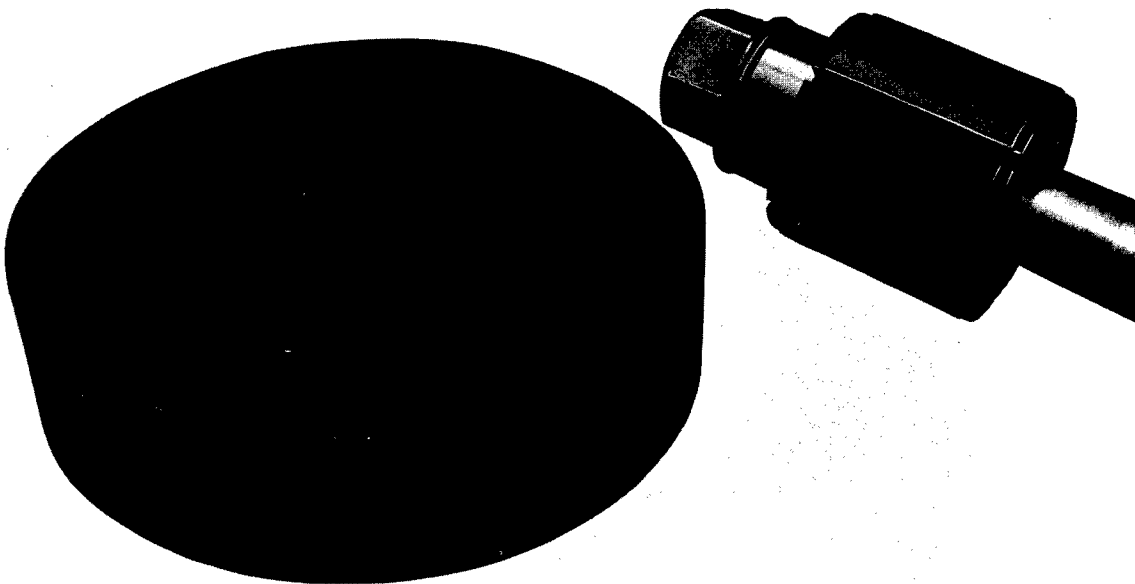

scratch when the finishing compound wore extremely thin, thus making it easier to attain flatness of flat work and roundness of cylinders and bores.

Hard-anodized aluminum laps were first used on air-bearing parts made of beryllium. Completely scratch-free surface finishes of 0.5 microinch were achieved. In contrast beryllium parts lapped on plates formerly used were considered excellent if they had 2-microinch finishes.

Again, a finish of 3.35 microinches was attained on 4032 aluminum before anodizing, and a 2.75-microinch finish after anodizing. The new method improved considerably on the best

results previously achieved, finishes of 6 to 8 microinches before anodizing and 4 to 6 microinches after anodizing. All tests were performed on bores as well as flat surfaces.

The aluminum lap may be modified by charging the aluminum lap plate with diamond compound, then hard anodizing and polishing with a charged felt pad to expose the diamond compound. The result is a high-quality, preimpregnated hard-anodized aluminum lap that will outperform and outlast any other lap known. All commercial rights to this invention are the property of W. J. Abernathy, the inventor.

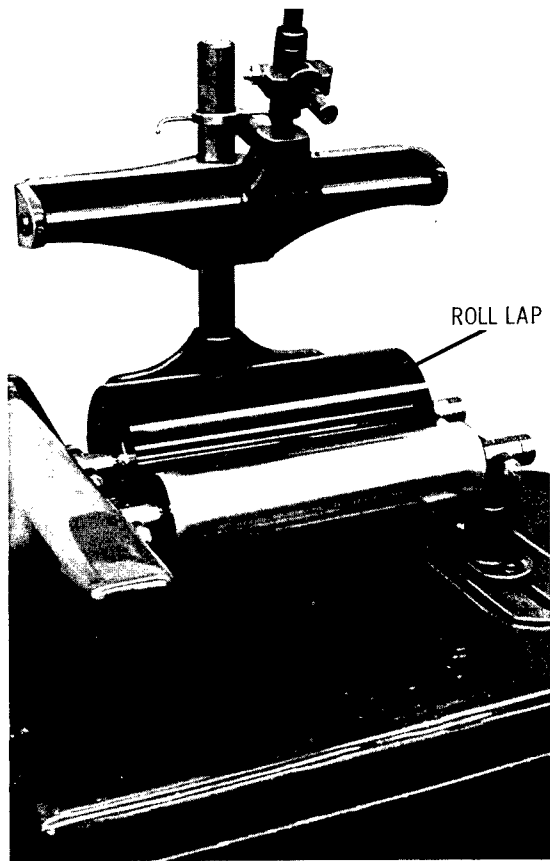

FIGURE 4.—Hard-anodized aluminum roll lap.

Machine for Lapping Spot Faces

Lapping Machine Increases Precision and Eliminates Damage to Air Bearing End Plates

Innovation by WILLIAM J. ABERNATHY, WILLIAM J. REED, JOHN R. SEALY, and LOWELL G. SNODDY

Marshall Space Flight Center specifications for generating spot faces on air bearing end plates call for recessing the faces to close tolerances for uniformity of depth and quality of finish. To meet these tight requirements, personnel of the Beryllium Facility Machine Shop of the Astrionics Laboratory built the lapping machine shown in figure 5.

Employing the principle of the radial lap made it possible to hold closer tolerances in flatness, surface finish and uniformity of depth than had been achieved with any other method. Machine lapping also completely eliminated metal chipping, structural fracturing around air nozzles and the spiral pattern produced by the formerly used method, single point tooling.

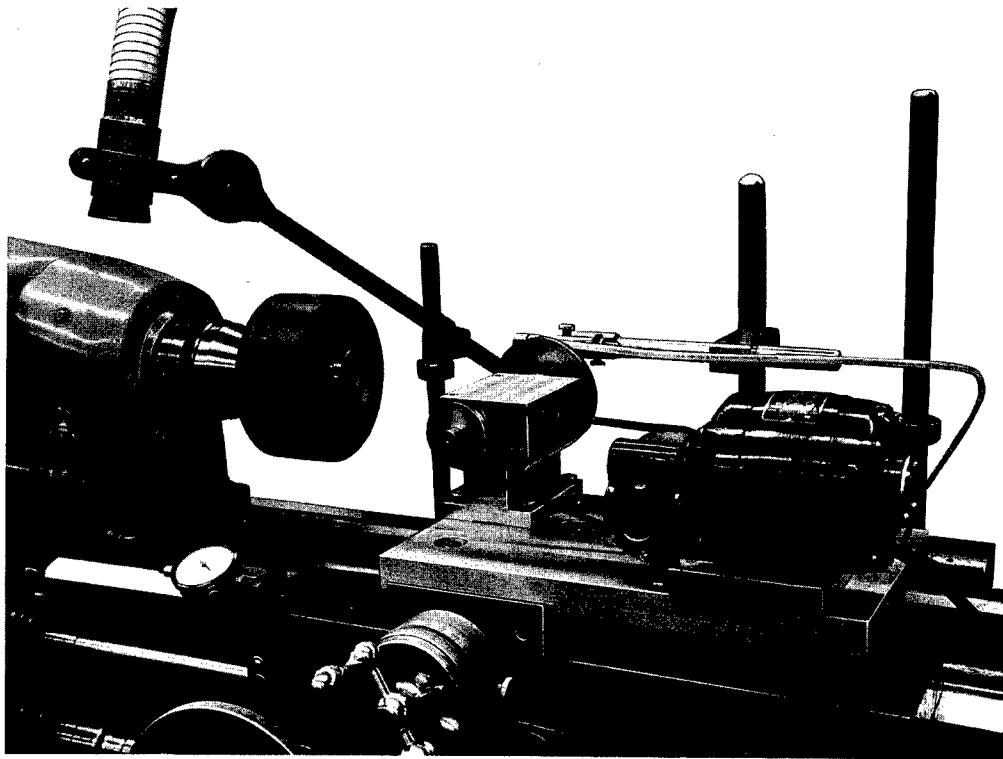
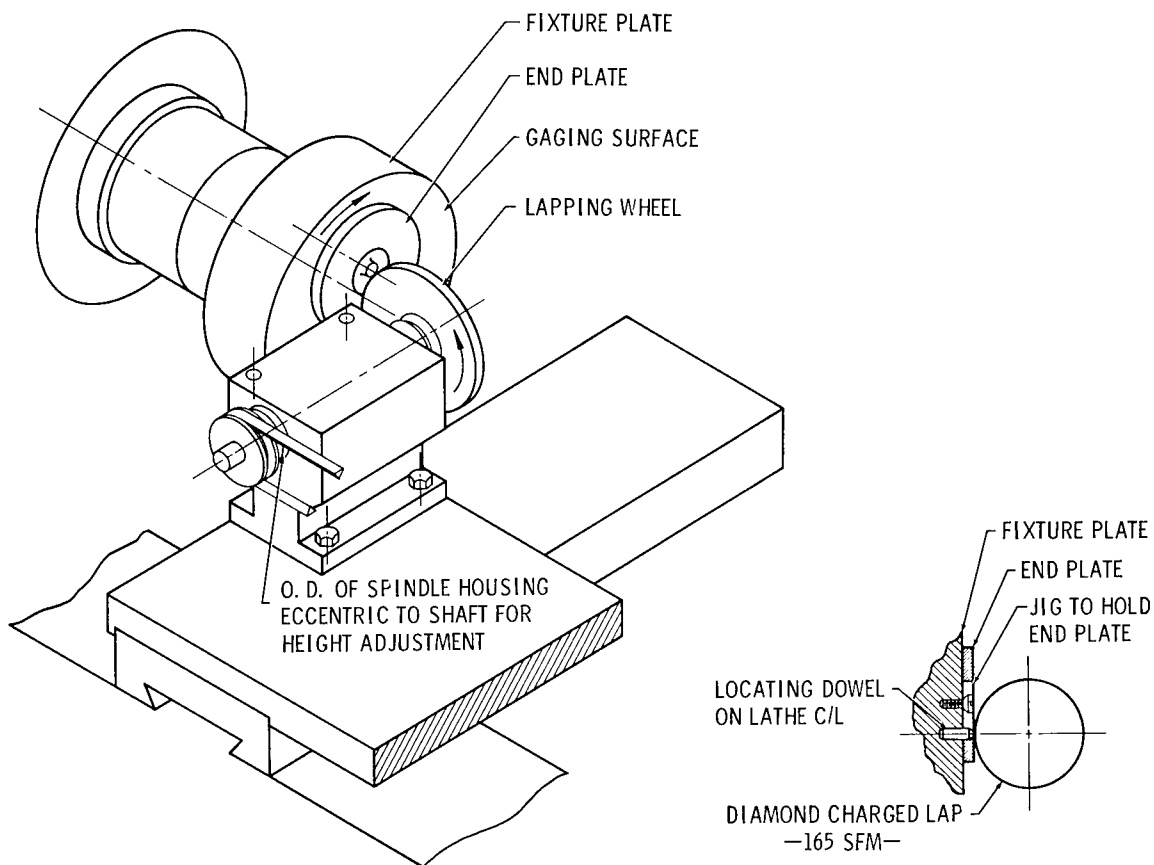

FIGURE 5.—Spot-face lapping machine.

Figure 6 shows details of the lapping machine, which was built to generate precision circular spot faces, 0.218 inch in diameter by 0.0002 to 0.0004 inch in depth, coaxial with the air nozzles (holes 0.018 inch in diameter) in an air bearing end plate. Specifications held the allowable variation in depth of the shallow faces to a maximum of 0.0001 inch.

Components of the machine are a base plate mounted on a lathe carriage, a small drive

motor, a bearing block, an adjustable bearing housing and a spindle with a lapping wheel. Bearings are made of oilite bronze, and the bearing housing of steel. The housing has an eccentric bore for adjustment and is fitted to a support block with honed surfaces. The spindle is made of steel and lapped for precision fit. Two graphite-impregnated nylon thrust washers, one on each end of the shaft, and a clamping nut on the spindle eliminate thrust.



TOOLING USED TO SPOT FACE ORIFICE HOLES IN END PLATE TO DEPTH OF .0003±100 MU

FIGURE 6.—Spot-face lapping machine.

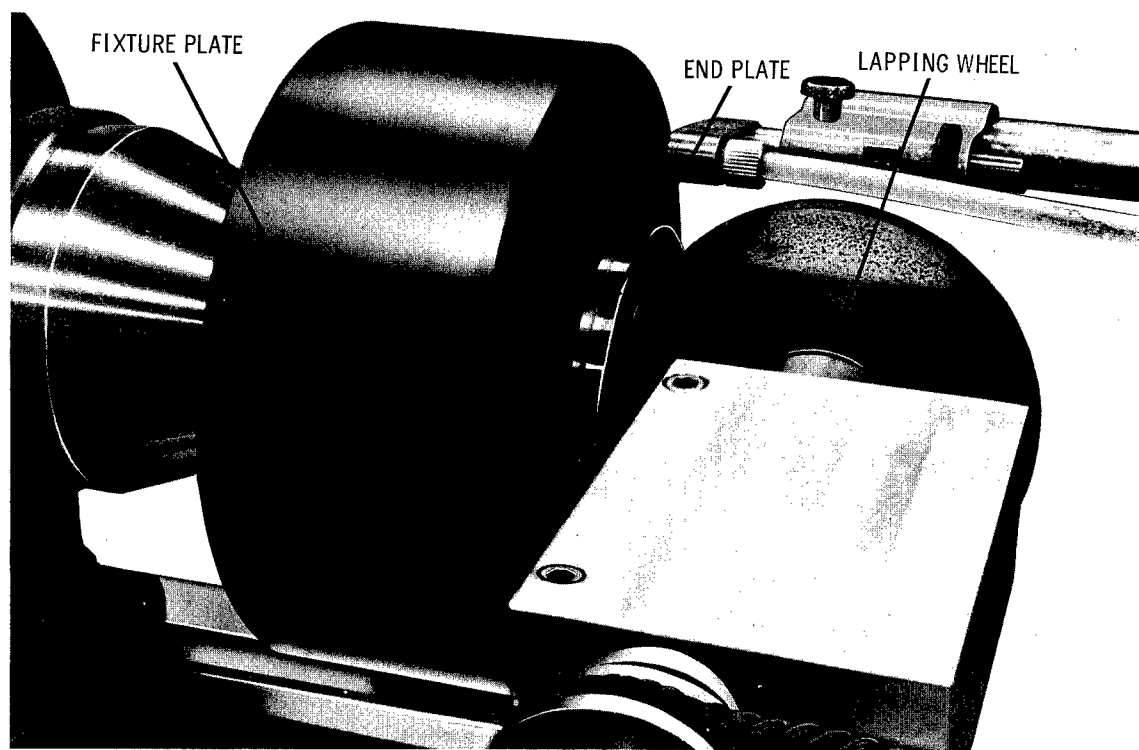

FIGURE 7.—Diamond-charged meehanite lapping wheel.

The lapping wheel, made of cast iron (meehanite) and charged with diamond compound, is shown in figure 7. The wheel is equal in width to the diameter of the spot faces to be generated. In assembly, the wheel is mounted on the spindle, then turned and lapped on its own bearings to the finish necessary to insure a true concentric surface. The wheel is then charged with diamond lapping compound and centered on the radial axis of the lathe spindle (figs. 5, 6 and 8). Running the lathe spindle at about 625 revolutions per minute and the lapping machine at about 165 rpm produces a highly uniform spot face.

The first spot faces produced by this method were on beryllium air bearing end plates. Uniformity of depth from one face to another was within 30 microinches, compared with the production tolerance of 100 microinches.

A bonus result of machine lapping over point tooling is that the periphery of the spot face blends smoothly into the surface of the plate, creating the least possible disturbance of airflow (fig. 9).

The lapping machine has also been used to generate annular grooves, 0.125-inch wide and 0.002-inch deep, to the same exacting tolerances in air bearing end plates.

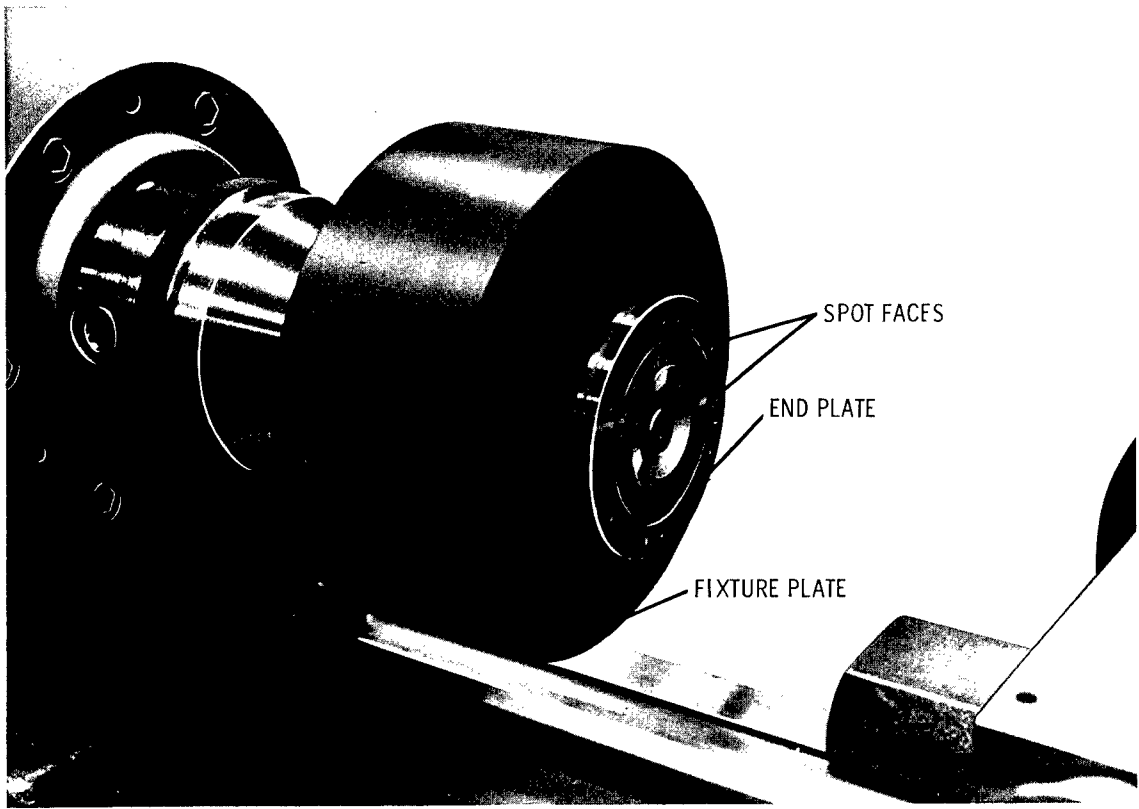

FIGURE 8.—Hard-anodized lapped aluminum fixture plate.

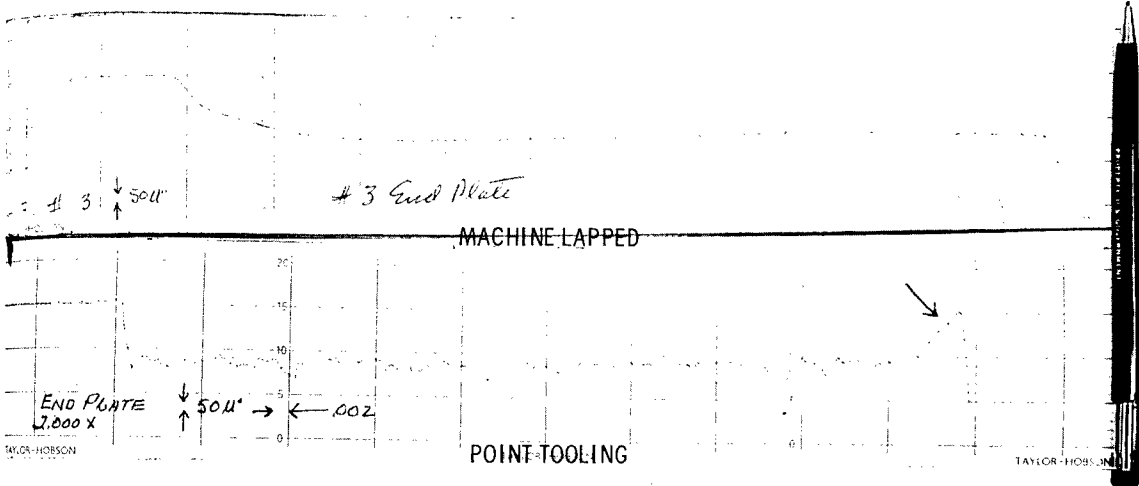

FIGURE 9.—Lapping-machine-generated spot face vs. point tooling.

Instrument for Determining Squareness or Perpendicularity

Instrument Speeds Determinations of Squareness or Perpendicularity of Machined Parts

Innovation by EDWIN WHITE

The Measuring and Testing Unit of the Astrionics Laboratory has developed a measuring instrument that sharply reduces the number of personnel and time required to determine the squareness or perpendicularity of machined parts. Formerly, two men using an autocollimator or theodolite needed about six hours to meet the Marshall Space Flight Center's requirement of checking the perpendicularity of alignment pads on the ST-124 guidance platform of the Saturn vehicle. Now one man can do the same job in about one-half hour with the new Indicator Differential Measuring Device (IN-DIF).

IN-DIF (fig. 10) uses indicator differential gages to measure squareness and/or perpendicularity to 0.0001 inch.

The instrument was machined with two sets of three positioning pads (figs. 11 and 12) lapped at right angles to each other. The upright gage member (shown during assembly in fig. 12) has 19 holes, $\frac{3}{8}$ inch in diameter on $\frac{1}{2}$ -inch centers, for insertion of the indicator differential gages. The gage holes are normal to the pads on the upright member and parallel to the pads on the base member. Each hole has a setscrew for fixing the gages in position.

Only a few simple steps are required to prepare the instrument for use. The device is positioned on a surface plate (fig. 11) so that it is resting on three pads (fig. 12) and the gage holes are perpendicular to the plate. The indicators are inserted into the selected holes, and the indi-

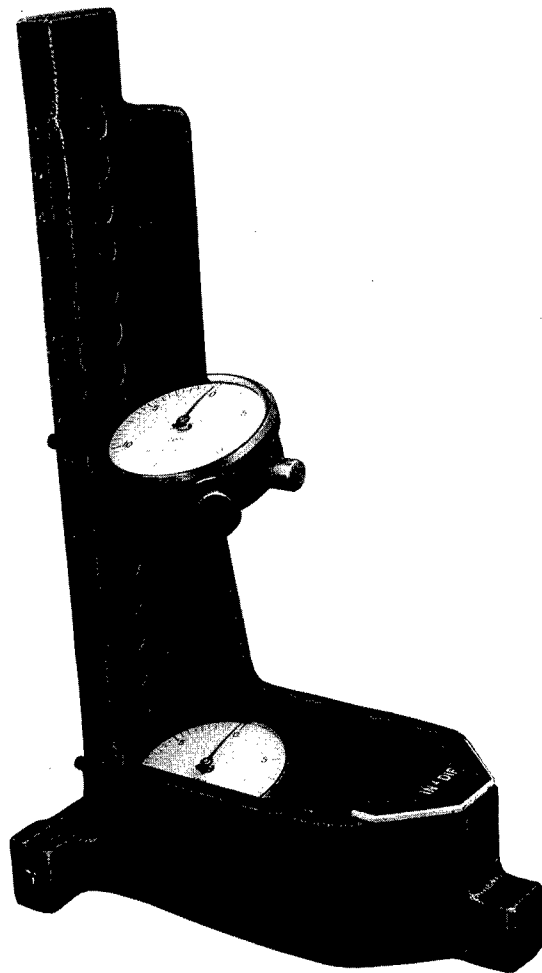

FIGURE 10.—Indicator differential gage measuring device.

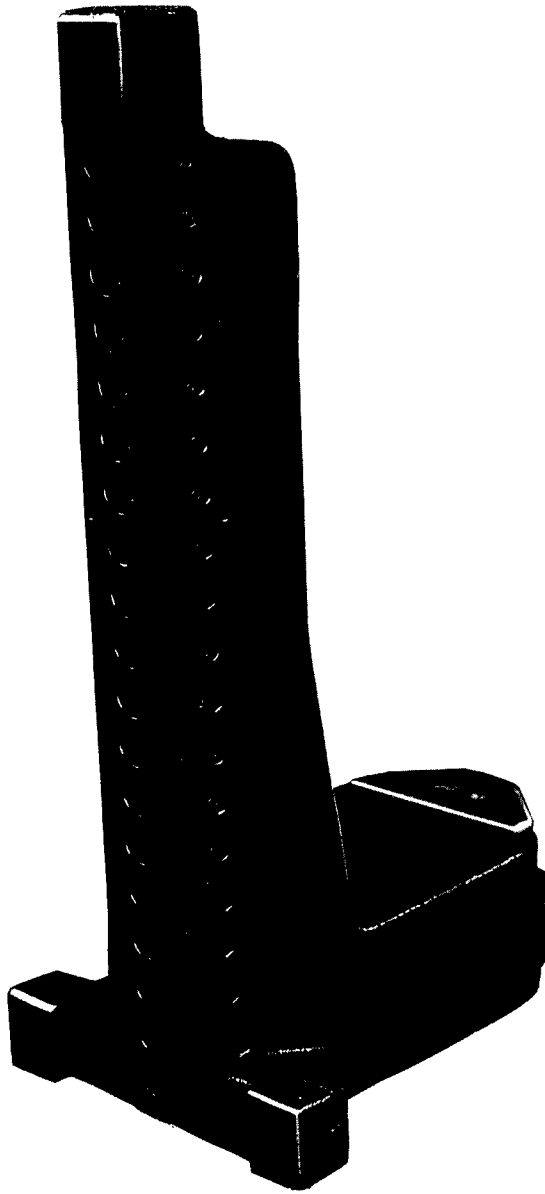

FIGURE 11.—Squareness and perpendicularity determining device positioned on surface plate and showing three positioning pads lapped in same plane.

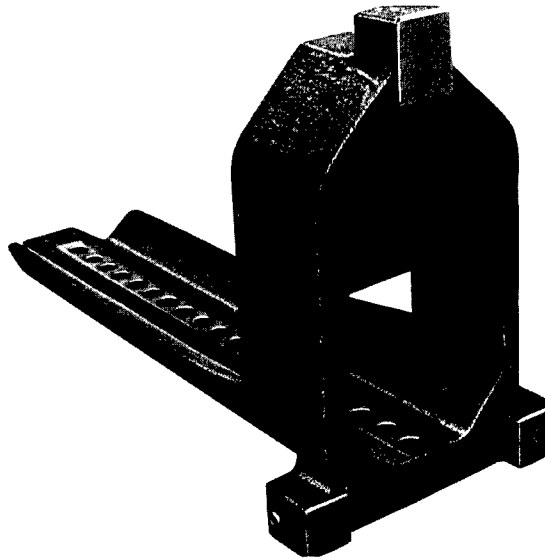

FIGURE 12.—Three positioning pads lapped in same plane and perpendicular to gage holes.

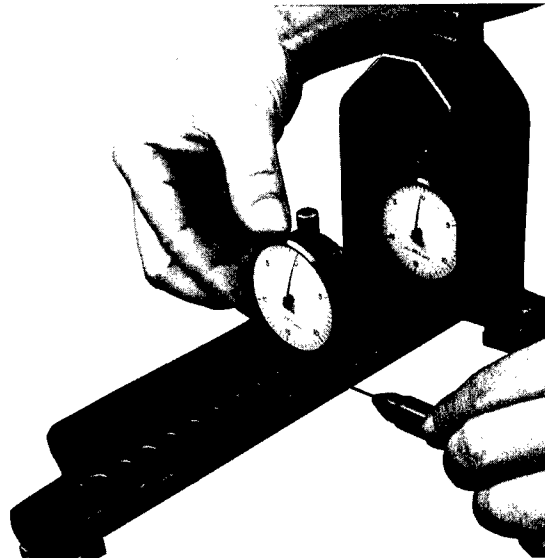

FIGURE 13.—Adjusting and securing indicator differential gages.

cator points are pressed against the surface plate until a plus reading is registered. The indicators are then secured in place with setscrews (fig. 13) and the dials zeroed. The device is then set upright and is ready for use. The indicator points are simply brought into contact with the work to be measured (figs. 14 and 15).

IN-DIF eliminates all vertical movement. The instrument can be set in $\frac{1}{2}$ -inch vertical increments, up to 10 inches. Slight angles can

be determined because the difference in the readings of the two indicators, considering their spacing, is the sine of the angle.

The instrument was not intended for extremely accurate measurements where a fraction of a second of arc must be determined. Readings of such accuracy are seldom needed, however, and IN-DIF can perform most required measurements.

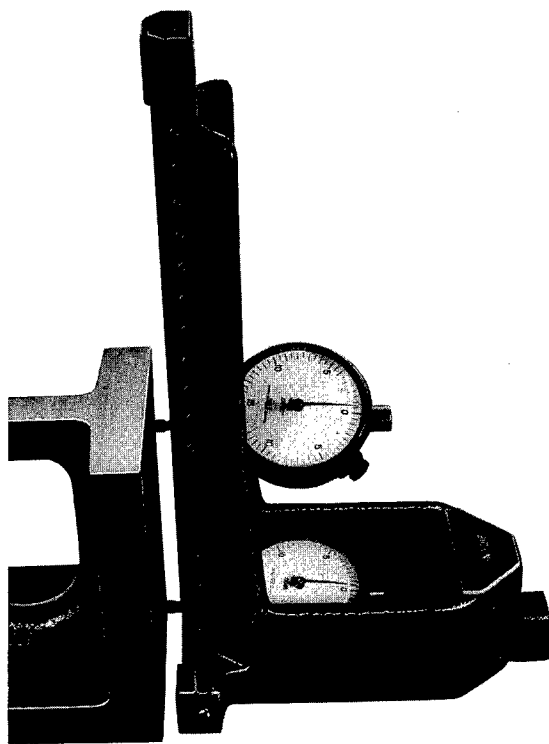

FIGURE 14.—Determining squareness and perpendicularity of machined part.

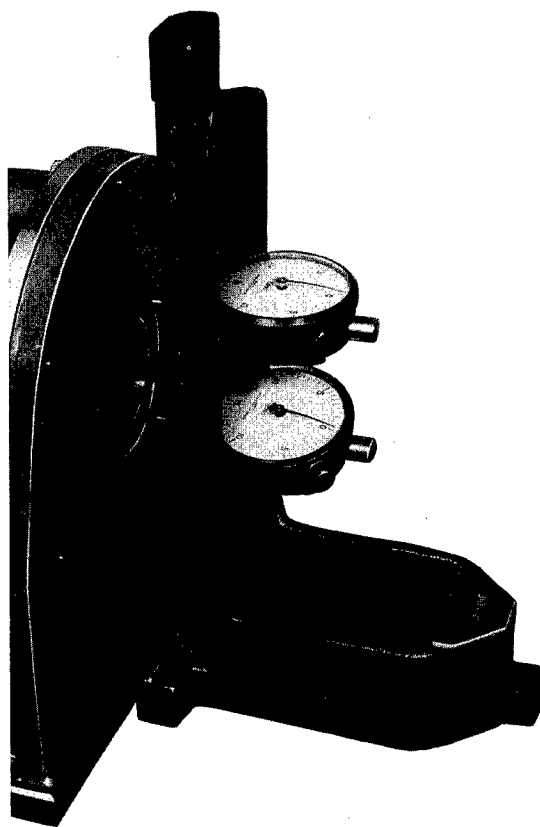

FIGURE 15.—Determining squareness and perpendicularity of machined part.

Tool for Measuring Deviation From Parallel

Air Bearing Mounted Measuring Device Is Simplified Tool for Determining Deviation From Parallel of Precision Parts

Innovation by WILLIAM J. ABERNATHY

Precision machine shops have a continuing need for simple, rapid methods of gaging precision parts before they are finished and face acceptance inspection. Now measurements of parallelism can be made to within 10 micro-inches at any time during the manufacture of precision parts by the use of a simple device incorporating an air gage. A part can easily be checked for deviation from parallel in about one-fifth the time required to measure the part directly on an Indi-Ron.

The instrument (fig. 16) consists of an air bearing, a 10,000-to-1 air gage, and a precision-lapped air-bearing cylinder. The top surface of the cylinder was serrated (fig. 17) to serve as a table for the part to be measured. The air bearing and cylinder were made of aluminum that was hard anodized for resistance to wear. The cylinder was lapped to float in the air bearing, and the top surface of the cylinder was lapped perpendicular to its centerline or axis. Runout was less than 10-millionths of an inch.

The part to be measured is secured to the table by a special screw and washer and rotated slowly under the air gage pickup. The motion of the gage indicator gives a direct reading on the location and amount of deviation from parallel in the part.

The measuring instrument can be used in any clean precision machine shop or quality control laboratory.

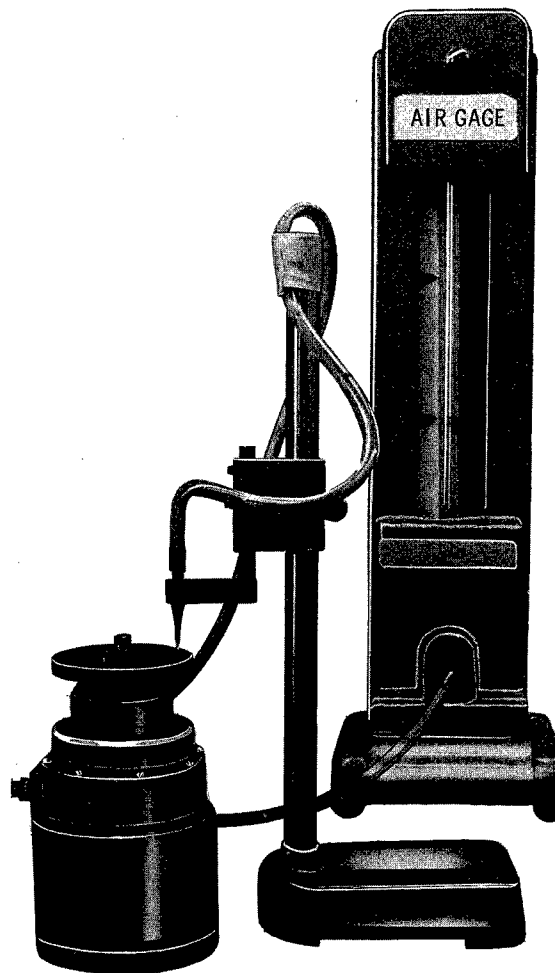

FIGURE 16.—Air-bearing-mounted measuring device for determining deviation from parallel, including air gage.

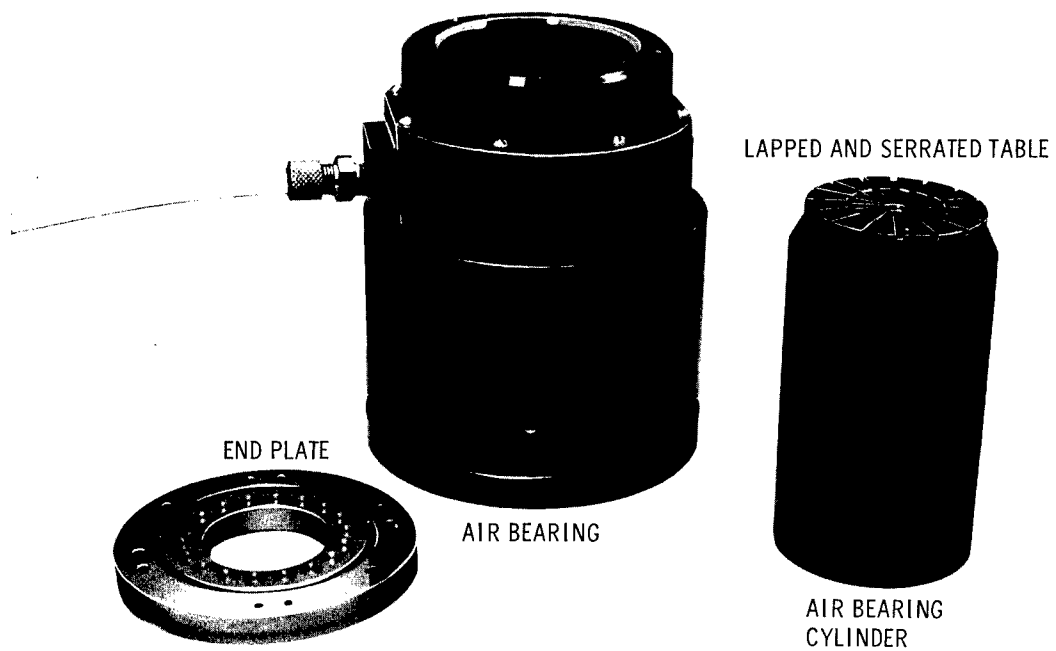

FIGURE 17.—Air bearing assembly including air bearing end plate.

Chamfering Small Holes

Soft Solder and Piano Wire Make Effective, Inexpensive Tools for Chamfering and Deburring Small Holes

Innovation by WILLIAM J. ABERNATHY

Even microscopic burrs on small holes cannot be tolerated in the manufacture of air-bearing parts because they restrict and disturb airflow. The fineness of the chamfering and deburring work required created a problem until unique tools were devised from small-diameter soft solder and piano wire charged with diamond compound. The small, inexpensive tools simplified work on a variety of small holes.

CHAMFERING LAPS

Solder-ball laps are made of solder a few thousandths of an inch smaller in diameter than the hole to be chamfered. A 6-inch length of solder is cut and held vertically over any handy source of heat (a lit cigarette will do). When the lower end of the length of solder has melted and the heat is removed, a small, tear-shaped

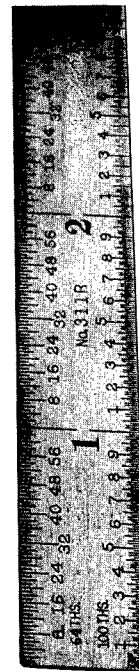
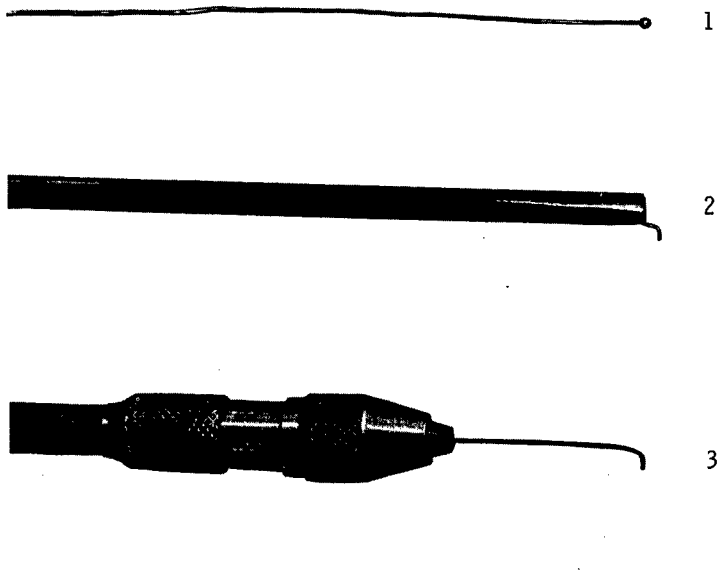

FIGURE 18.—Tools for chamfering small holes.

ball is formed (1 in fig. 18). With a little practice, a man can make two or three dozen solder-ball laps, to a tolerance of 0.002 to 0.005 inch, in a few minutes.

Chamfering is equally simple. A small amount of lapping compound is placed on the solder ball before use. The end of the length of solder opposite the ball is then inserted into the hole to be chamfered, and the solder drawn through until the ball contacts the surface of the work. The solder, held between thumb and forefinger, is spun back and forth in the hole. Allowing some slackness in the shank of the solder gives the ball more whipping action, which improves the uniformity of the chamfer and gives the lap a longer life.

Experience has shown that three to five holes of 0.018-inch diameter can be chamfered with the 6-inch length of 0.015-inch-diameter solder. Average ball size is 0.035 inch.

DEBURRING WIRE

Piano wire charged with diamond compound is effective for deburring blind holes or holes

drilled at angles other than 90 degrees to the surface. The wire method can also be used in places where the solder-ball method is not practical.

The wire is charged by rolling it between two hardened and ground pieces of steel, such as lathe tool bits. The charged wire is held in a pin vise (3 in fig. 18 and A in fig. 19) for the chamfering operation.

The charged-wire method has made it a fairly simple matter to chamfer holes that were formerly considered to be extremely difficult, such as the one shown in figure 20. The 0.028-inch hole extending through the sidewall into a 0.218-inch counter bore required a special lap. The tool used consisted of a short piece of wire, bent to form a crank, and a short rod to serve as a crank handle. The wire was secured for use by running one end of it through a hole in the end of the rod and pinching it to keep it from falling out. The assembled tool is shown in 2 of figure 18, and its principal of operation in B of figure 19.

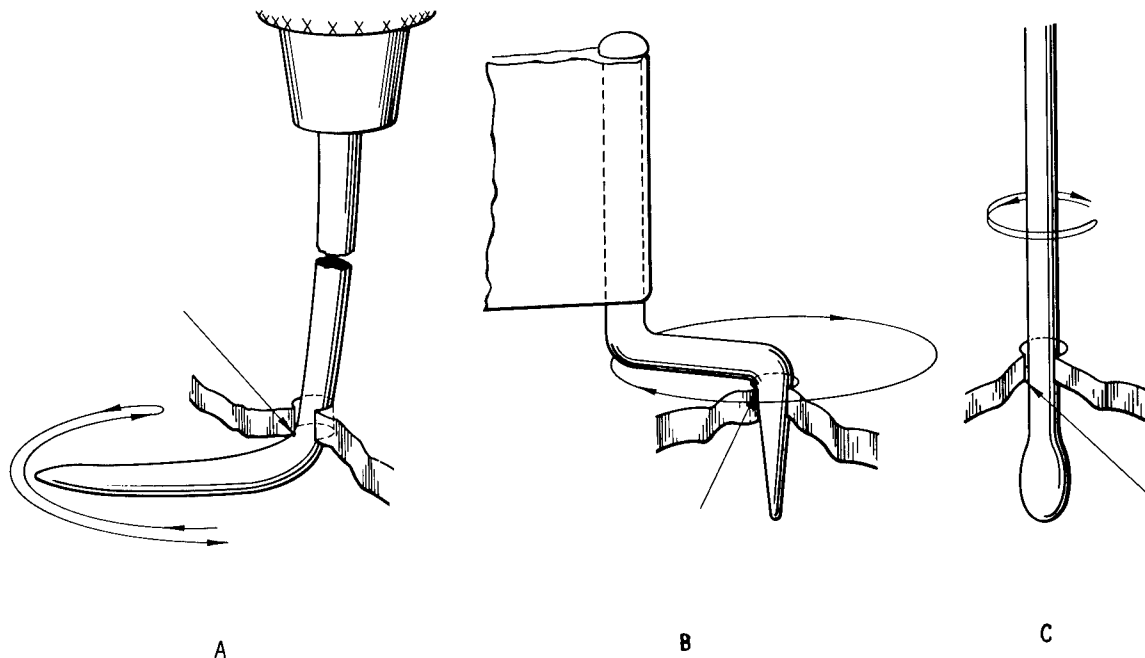

FIGURE 19.—Examples of way chamfering tools are used. A. Charged piano wire lap held in a pin vise. B. Crank-type piano wire lap. C. Solder-ball lap.

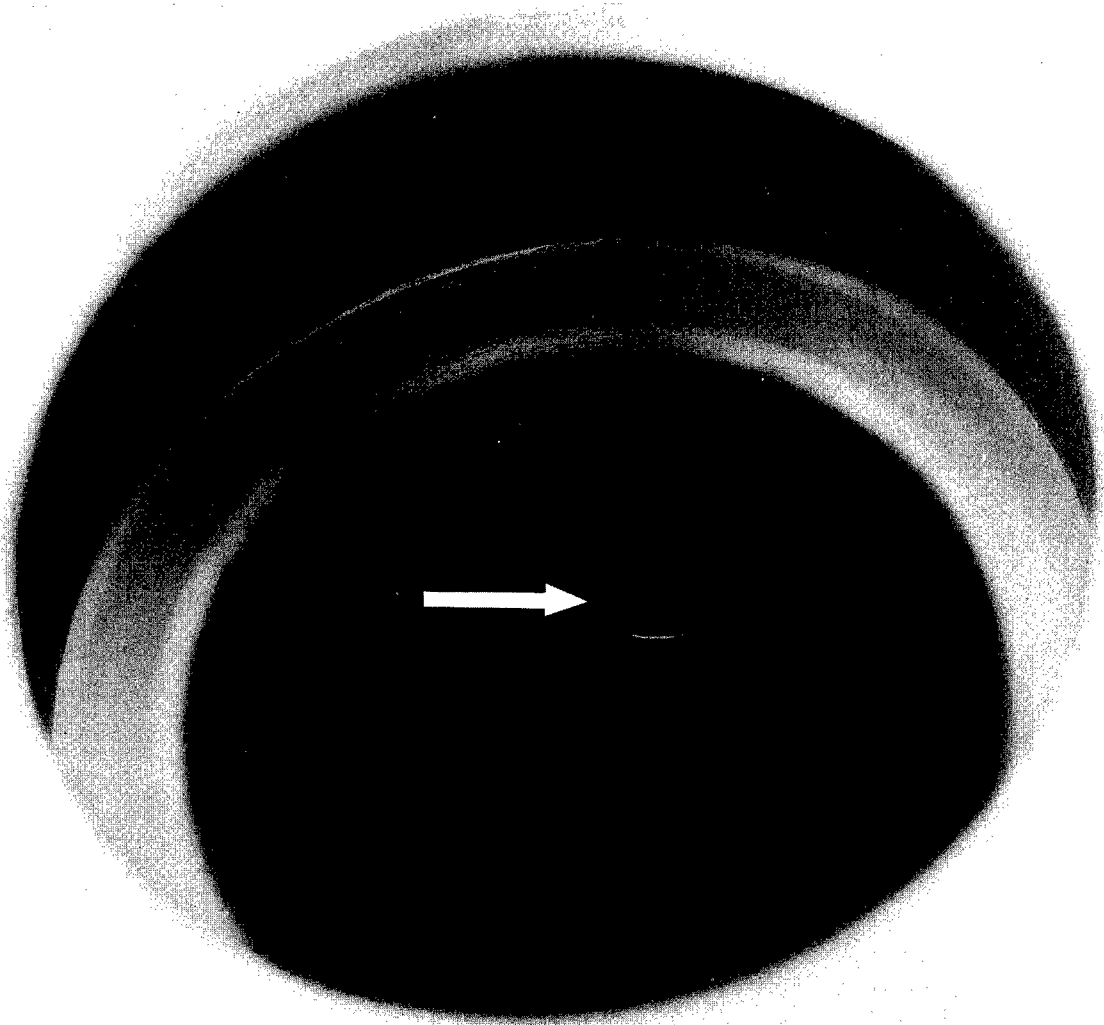

FIGURE 20.—Example of hole chamfered using piano wire crank as shown in Figures 18(2) and 19(B).

Universal Lathe and Jig Bore Fixture Holder

*Adaptable Fixture Standardizes Setup Procedure and Facilitates
Machining of Parallel Parts*

Innovation by JOHN R. SEALY

Personnel of the Beryllium Facility Machine Shop of the Astrionics Laboratory are continually looking for new methods and techniques to improve their capability to perform precision machine work. Their efforts turned up an important shop aid in a fixture holder that can be used with a lathe or a jig bore and allows

transfer of a part from one machine to the other with a minimum of setup time. The fixture holder increases accuracy in machining parallel parts in addition to standardizing setup methods and procedures for both the lathe and jig bore.

The fixture holder (fig. 21) is made of hard-anodized aluminum to resist wear. It has two

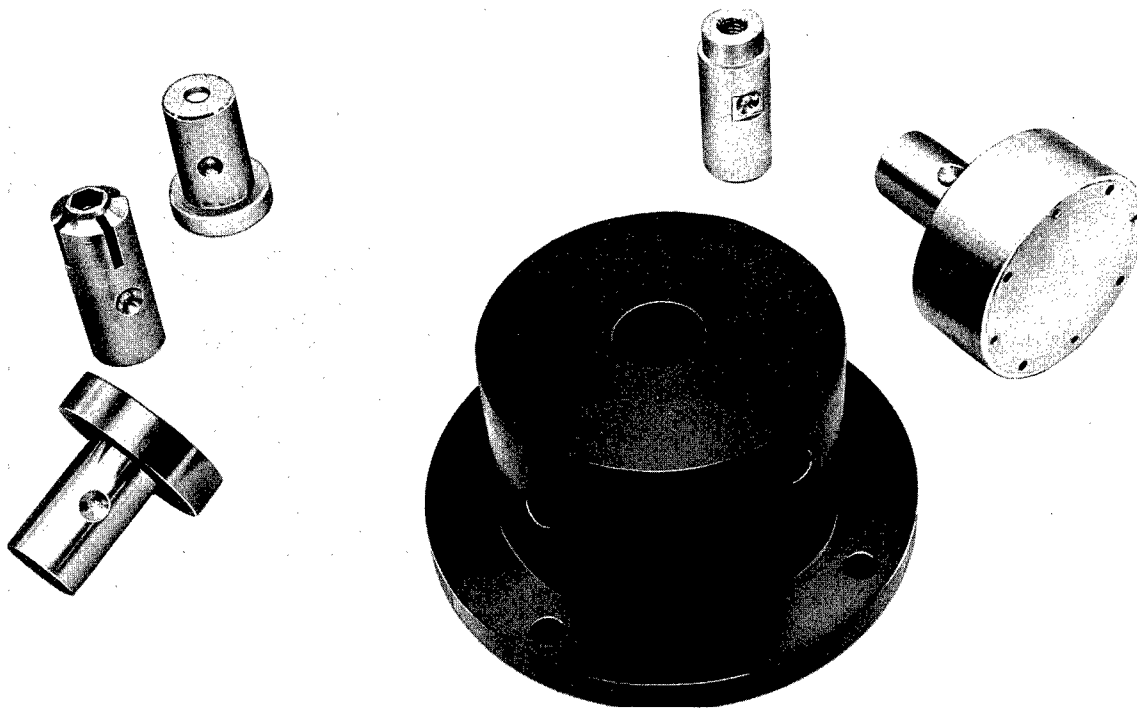

FIGURE 21.—Lathe and jig bore fixture holder and variety of one-inch brass inserts.

lapped faces that are parallel to within 5-millionths of an inch. Each face has a 1-inch hole through the center, perpendicular to the parallel-lapped faces. The holes are equally sized and lapped to within 20-millionths of an inch. A $\frac{3}{8}$ -inch setscrew in the side of the fixture is provided to lock an alinement insert in place.

A variety of brass inserts may be used interchangeably with fixtures mounted on a lathe and a jig bore, depending on the operation required. The inserts have shanks that fit the 1-inch hole in the fixtures with a clearance of one ten-thousandths to two ten-thousandths of an inch. For work on high-precision parts, such as air bearing end plates that require a high degree of parallelism, a split insert with a tapered-head screw

in the end is used to lock the part in place. (See fig. 22.) The bore of the end plate is slipped over the insert, locked in place and tapped back against the true face of the fixture (fig. 23).

Another type of insert used with the fixture is solid, with a tapped hole in the end. The work piece is slipped over the lineup screw and locked in place with a screw and large washer.

PREPARATION FOR USE

A lathe, to be used with the fixture, is first prepared by mounting a stress-relieved backup plate to the face plate. The backup plate is cut as true and perpendicular to the axis of the lathe as the runout of the lathe spindle bearing will permit. The precision of this part can be

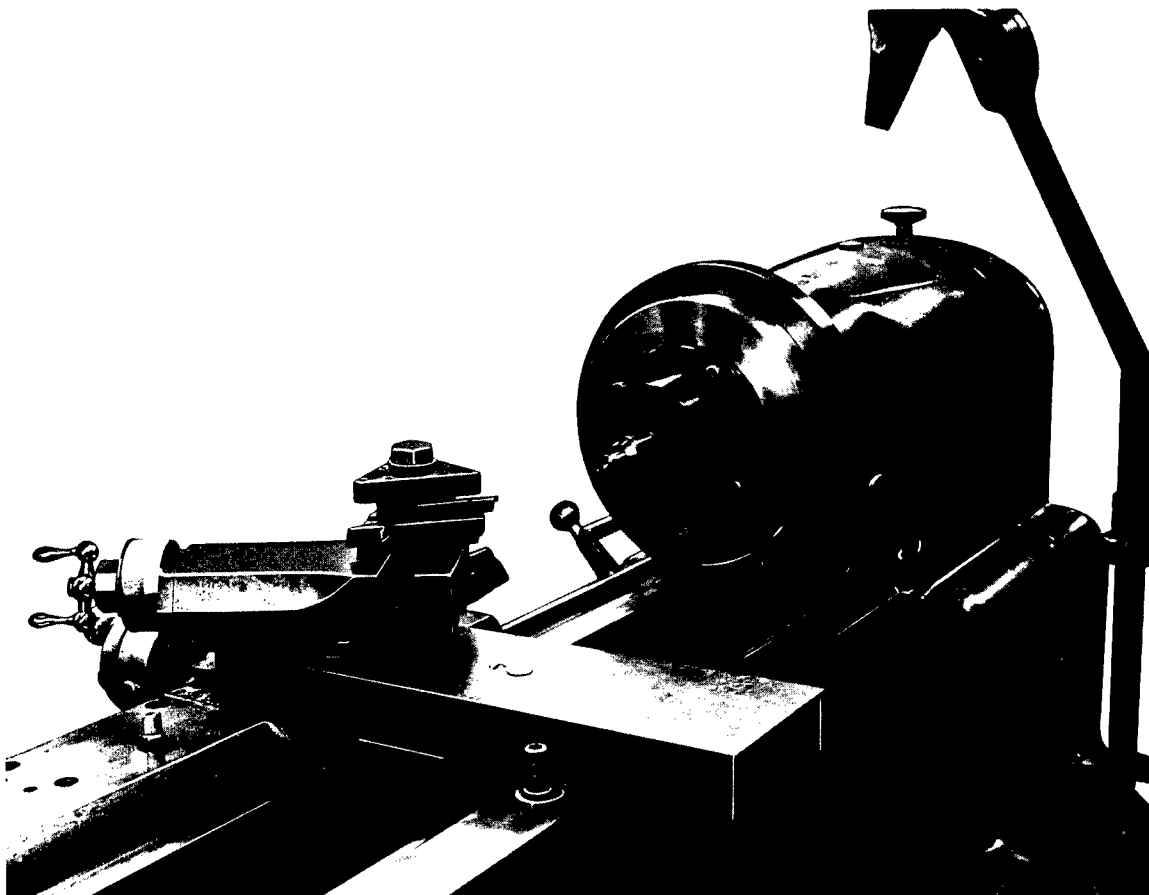

FIGURE 22.—Lathe-mounted fixture holder with split-brass insert displaying tapered screw.

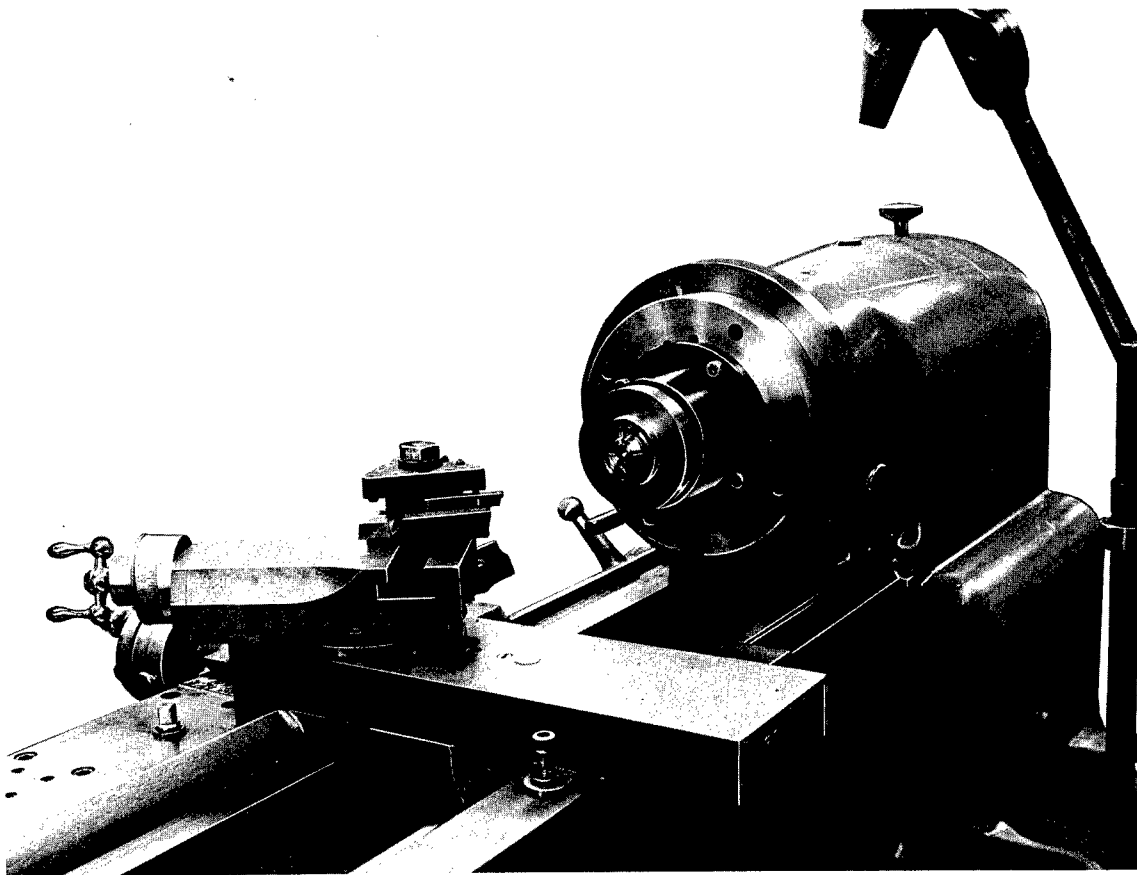

FIGURE 23.—Air bearing end plate (prior to machining) mounted on fixture holder utilizing split-brass insert.

improved by making a number of passes on the backup plate without moving the lathe carriage.

The fixture holder is lapped front and rear to make it true and parallel. The center hole is then bored and lapped concentric with the lathe axis and perpendicular to the two faces. The surface of the fixture is then hard anodized. After the anodizing, the front and rear faces are lapped parallel to within 5-millionths of an inch. The hole is then lapped to a smooth finish parallel to the lathe axis.

The prepared fixture holder is mounted to the backup plate with mounting studs and is trued with an air gage to within the limits of the lathe spindle bearing runout. The runout limits of

the spindle bearing may vary between 18-millionths and 35-millionths of an inch.

Of 10 pieces machined with the use of three fixture holders, 7 were within 20-millionths of an inch of parallel, and the remaining 3 were within 50-millionths of an inch. Specifications called for parallelism within 35-millionths of an inch after the parts were lapped. These dimensions were held, despite the lathe spindle bearing runout, by making multiple runs on each cut without changing the lathe carriage position.

When used with a jig bore, the fixture is mounted directly on the precision turntable (fig. 24).

The old method of paralleling required the machining of a complete new fixture for each new part to be machined. In cases where a split backup surface was used, the parallel characteristics changed when the fixture was ex-

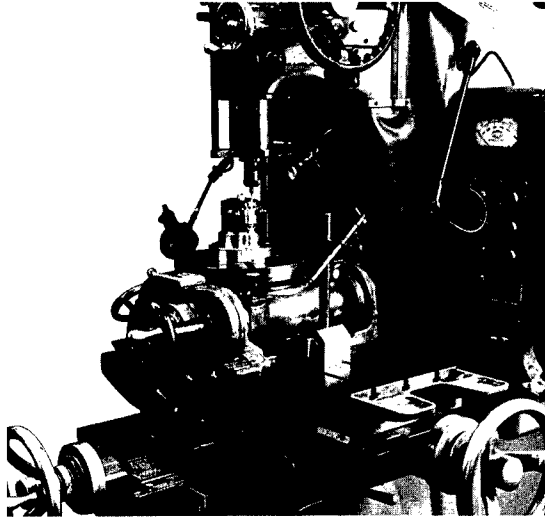

FIGURE 24.—Gyro housing mounted to jig bore precision turntable utilizing special fixture.

panded to hold the work. The advantage of the universal hard-anodized aluminum fixture holder over past methods is indicated by the illustration showing some of the fixtures it has replaced (fig. 25).

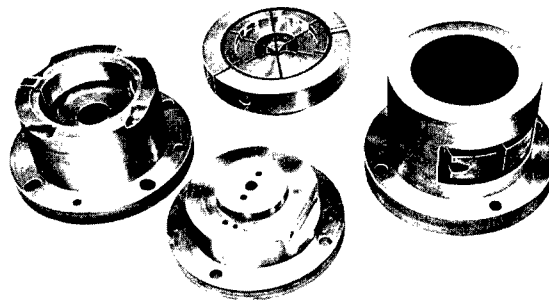

FIGURE 25.—A sample of fixtures replaced by new precision hard-anodized aluminum fixture holder.

Precision Lathe Mounting Ring

Special Device Allows Precision Machining of Parts Requiring Many Parallel Surfaces and Concentric Bores

Innovation by JOHN R. SEALY and LOWELL G. SNODDY

In preparing and tooling-up for the manufacture of a special gyro housing, personnel of the Beryllium Facility Machine Shop decided they needed a new tooling technique to attain the strict tolerances required for the parts. They devised a lathe mounting ring to meet one of the problem jobs—the precision machining of parts requiring multiple parallel surfaces and concentric bores. The surfaces of each part had to be faced-off parallel to lapped reference pads, and bores made concentric to the axis of the part to within 50-millionths to 60-millionths of an inch.

Figure 26 shows the lathe mounting ring, the special backup plate and a typical work piece—a gyro housing and cap. The mounting ring, made of aluminum, was machined, lapped to within 5-millionths of an inch of parallel, and

hard anodized. It was then mounted on the aluminum backup plate, which was machined perpendicular to the lathe axis to within 20-millionths of an inch.

The gyro housing was cut to general shape as precisely as possible on the lathe and jig bore shown in figure 24. This work included machining three mounting lugs (A in fig. 27) on the outside surface of the housing.

The housing was attached to the mounting ring, with the lapped surfaces of the mounting lugs facing the lapped surface of the ring. The mounting ring, in turn, was attached to the backup plate (figs. 28 and 29).

One face of the gyro housing was cut perpendicular to the housing axis and parallel to the surfaces of the mounting lugs. Two bores were made concentric to the housing axis and

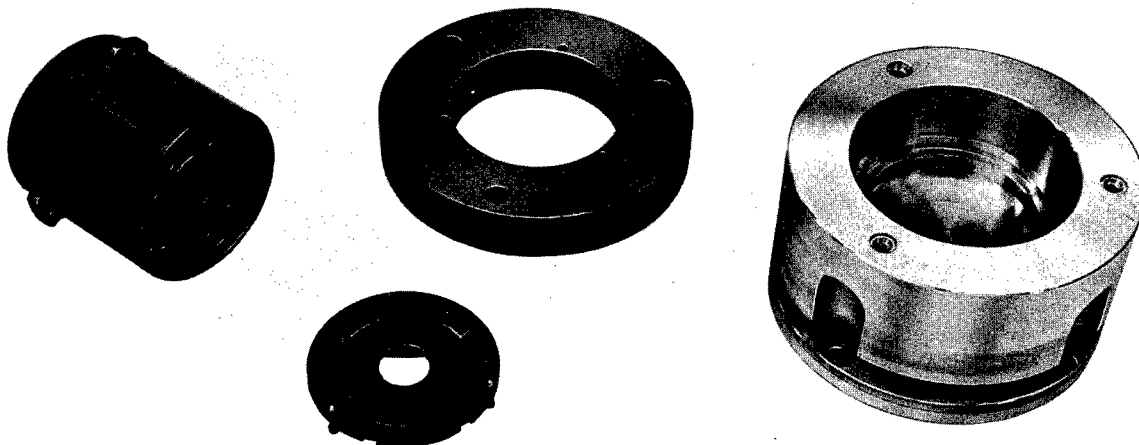

FIGURE 26.—Lathe precision mounting ring assembly and work piece. Left to right: gyro housing, gyro housing cap, precision mounting ring and aluminum backup plate.

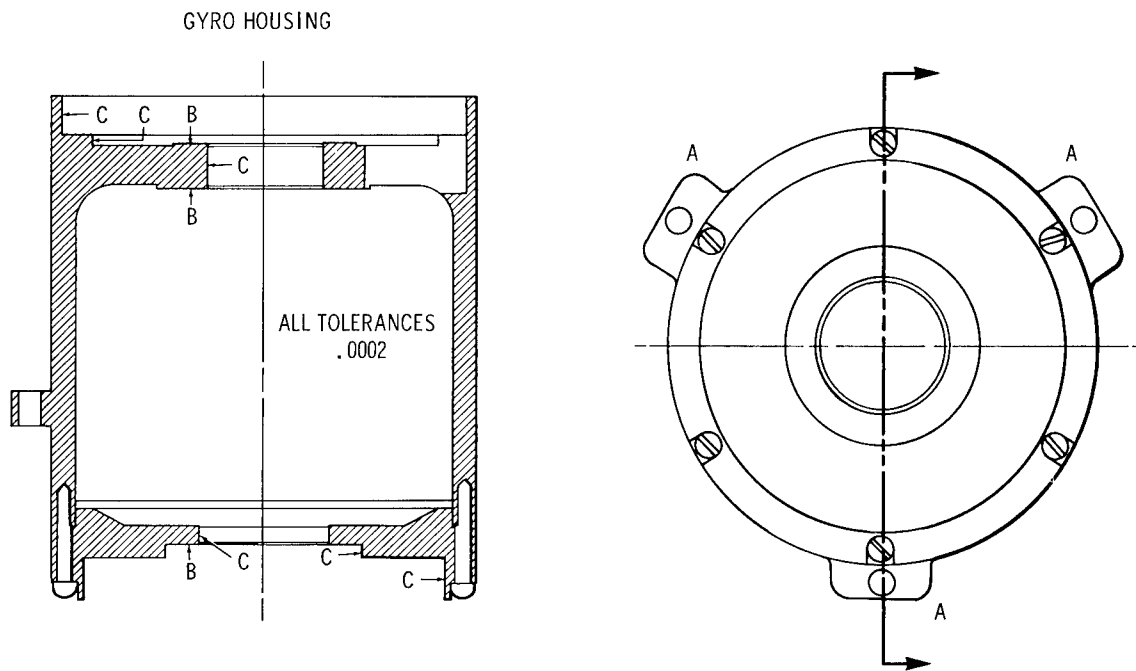

FIGURE 27.—Gyro housing. A. Lapped mounting lugs, B. Parallel faces, C. Concentric bores.

perpendicular to the surfaces of the mounting lugs. The mounting ring was then removed from the backup plate, reversed and centered with an electronic indicator.

Another face was cut on the inside surface of the housing, parallel to the outside face and to the faces of the mounting lugs. A bore was then made in the inside leading edge of the housing, concentric to the housing axis, for seating the housing cap.

When the machining operation on the gyro

housing was completed, the cap was mounted without removing the housing from the mounting ring. Two bores were made in the cap, concentric to the axis of the gyro housing, and one face was cut parallel to the main housing faces.

The mounting ring thus made it possible to cut surfaces parallel to the lapped mounting lug faces (B in fig. 27) and bores concentric to the axis (C in fig. 27) on a complete unit.

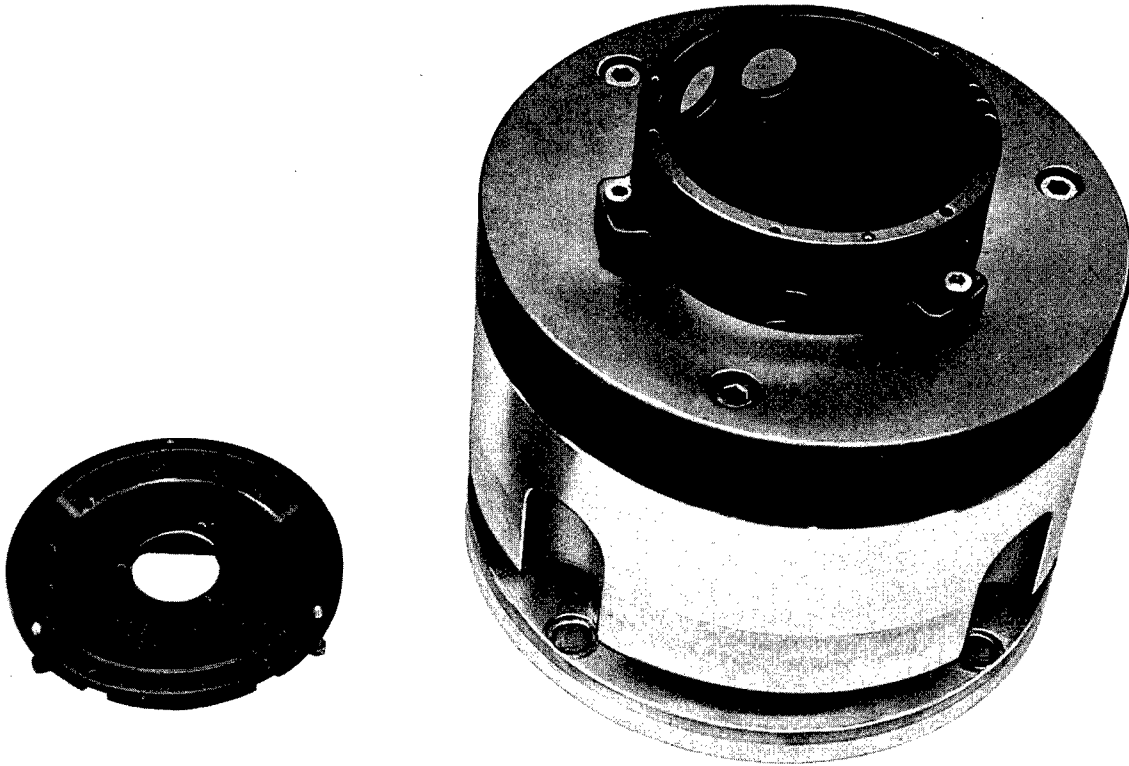

FIGURE 28.—Gyro housing and ring mounted on special backup plate in position used to make first concentric bores and parallel faces.

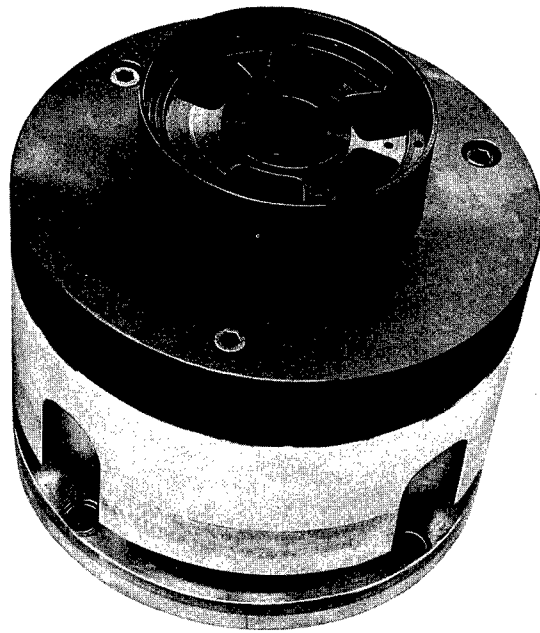

FIGURE 29.—Gyro housing mounted to precision mounting ring and in required position of backup plate for final cuts.