

P

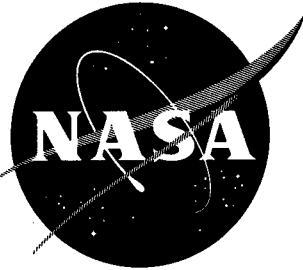

50919

TECHNICAL NOTE

D-1706

INFLUENCE OF FLUORINE ENVIRONMENT ON THE MECHANICAL

PROPERTIES OF SEVERAL SHEET ALLOYS

By Hadley T. Richards and Morgan P. Hanson

Lewis Research Center
Cleveland, Ohio

DISTRIBUTION STATEMENT A

Approved for Public Release
Distribution Unlimited

PROPERTY OF:

AMPTAC LIBRARY

20011129 071

NATIONAL AERONAUTICS AND SPACE ADMINISTRATION

WASHINGTON

April 1963

Reproduced From
Best Available Copy

NATIONAL AERONAUTICS AND SPACE ADMINISTRATION

TECHNICAL NOTE D-1706

INFLUENCE OF FLUORINE ENVIRONMENT ON THE MECHANICAL
PROPERTIES OF SEVERAL SHEET ALLOYS

By Hadley T. Richards and Morgan P. Hanson

SUMMARY

The effect of a ^{all} liquid-fluorine environment on the mechanical properties of several sheet alloys was investigated. The smooth and notch tensile strengths^{all} and the elongation properties^{all} of steel, nickel, aluminum, and titanium alloys were determined in liquid-nitrogen^{all} and liquid-fluorine environments (-320° F). Possible deterioration in the presence of fluorine and high stresses was detected by comparing the properties of alloys exposed to the two fluids at -320° F. The commercial-quality fluorine used contained contaminants.

The results of tests in liquid fluorine indicated possible degradation of the mechanical properties of the sheet alloys. Following 2 hour exposure, the decrease in tensile strength ranged from negligible to a maximum reduction of approximately 11 percent. Elongation showed similar trends. The sharp-notch strengths appeared to be unaffected by the liquid fluorine. Variations in test results and surface appearance could have been due to varying amounts of contaminants in the liquid fluorine. There was no evidence of ignition on any of the specimens that were fractured in the liquid fluorine environment.

INTRODUCTION

The desirability of using fluorine as an oxidant for rocket propellants is generally well known (e.g., ref. 1). Extensive use of fluorine, however, has been limited partly because of certain hazards of handling and storing this extremely reactive material. At this research center and in the industry, procedures have been developed that substantially reduce the hazards and problems of using and transferring fluorine. Because of the characteristic of rapid oxidation of fluorine with many materials, extensive compatibility tests have been made (refs. 2 to 6). At ambient temperatures (70° F) and at temperatures diminishing to -320° F, the compatibility between relatively pure fluorine and most metallic alloys has been satisfactory. Reference 6 reports the results of mechanical property tests on materials in an unstressed state that were exposed to relatively pure liquid fluorine for 1 year. The determination of mechanical properties was made in an air atmosphere at room temperature, and no significant changes were observed in the materials considered.

The possibility was considered that the results of references 2 to 6 might not be indicative of the effects that could be encountered if materials were in

a stressed state in a fluorine environment and the fluorine were of no greater purity than normally encountered in commercial lots. In the work herein, the stress to failure occurred in the fluorine, and, therefore, freshly fractured surfaces (i.e., they have no protective fluorides) would be exposed to the possible reactive effects of slightly contaminated fluorine. The present investigation was conducted on several sheet alloys that could be considered for use in pressure vessels. Sharp-notch and smooth sheet tensile specimens of steel, aluminum, titanium, and nickel-base alloys were investigated. The specimens were exposed to the fluorine environment in a stressed condition for 2 hours prior to continued loading to fracture. The specimens were passivated with gaseous fluorine prior to being stressed in the presence of liquid fluorine in a treatment similar to that experienced by rocket-vehicle propellant tanks.

In order to have data with which to compare the mechanical properties obtained in fluorine, specimens of the same sheet and heat treatment were also tested in an environment of liquid nitrogen (-320° F). In this manner, the test conditions were the same except that the relatively inert liquid nitrogen was substituted for the highly reactive liquid fluorine.

TEST SPECIMENS AND APPARATUS

Materials

The nominal chemical compositions, heat treatments, and thicknesses of the sheet alloys used in this investigation are given in table I. All materials were tested with specimens cut parallel to the direction of rolling.

Test Specimens

Dimensions of both the sharp-notch and smooth tensile specimens are shown in figure 1. The sharp-notch specimen essentially complies with that proposed for sheet screening work by the ASTM Committee on Fracture Testing of High Strength Sheet Materials (ref. 7). The specimens were machined from sheet, in the commercially supplied condition, with the machining limited to the edges. The radius of the sharp notch was less than 0.001 inch as determined by examination with an optical comparator at a magnification of 100.

Test Chamber

The test chamber, shown in an exploded view in figure 2, was a cylinder of 0.065-inch-wall, 304-stainless-steel tubing, approximately 11 inches long, with a serrated flange welded to the access end to accommodate a soft aluminum gasket. The opposite end, which was the top, had a 3-inch-long stainless-steel bellows capped with a compression fitting that was modified with a Teflon washer rather than the originally used stainless-steel ferrule. This arrangement sealed the top tensile loading rod to the chamber. The bellows permitted unrestrained motion of the upper specimen grip throughout load application. The difference in pressure from inside to outside across the wall of the bellows was slightly nega-

tive during operation with liquid fluorine. The lower grip was an integral part of the closing flange as shown in figure 2. The threaded hole in the center of this flange accommodated the lower tensile rod.

Figure 3 shows a sketch of the tensile loading apparatus, the test chamber, the liquid-nitrogen cryostat, and a schematic diagram of the supply piping for purging, filling, and emptying the test chamber. The tensile load was generated by a hydraulic ram mounted at the top of the loading frame. Hydraulic fluid under pressure was metered to the ram by means of a needle valve from a previously charged accumulator. The tensile load on the specimen was measured by a load cell utilizing strain gages for load indication. This load cell was so mounted that it was in compression when load was applied to the test section (fig. 3). The load cell was calibrated, at various times during the test program, in a hydraulic universal testing machine. The fluorine was supplied in gaseous form from a bank of cylinders, each containing approximately 6 pounds of commercial fluorine. Double valving and helium purging were used in this part of the system for safe control.

PROCEDURE

The general procedure throughout the investigation was to determine the basic mechanical properties (ultimate strength, 0.2 percent yield strength, percent elongation, and sharp-notch tensile strength) of each material in a liquid-nitrogen environment. Then, similar determinations (with the exception of yield strength) were made in an environment of liquid fluorine. However, the specimens, while under stress, were exposed to fluorine for 2 hours prior to the ultimate failure. For smooth tensile specimens, the hold stress applied was 90 percent of the 0.2 percent yield strength of the material tested in liquid nitrogen. For notch specimens, the hold stress was 90 percent of the failure stress in liquid nitrogen. The time of exposure was 2 hours in this case, also.

The use of liquid and gaseous fluorine required observance of special handling methods to ensure cleanliness in the various components of the test equipment. Any oil, scale, and so forth, which might react with the fluorine, were removed to avoid damage to test equipment, injury to personnel, or inaccurate test data. Generally, the same procedure was used for all components of the system. The details given in the following paragraphs apply specifically to the test specimen.

All specimens were degreased in a solvent and then immersed in a 20-percent nitric acid bath for about 5 minutes. When removed, they were thoroughly rinsed with water followed by an acetone wash to remove any remaining water. After the specimen was assembled in the grips and the test chamber was closed by attaching the cover and fluorine lines, the facility was purged and checked for leakage with helium gas to 30 pounds per square inch. This pressure was held within the facility for approximately 15 minutes. If no leaks were discovered, the system was evacuated and held for about 1 hour to check further for leakage.

When the system was determined to have no leaks, fluorine gas was allowed to flow into the lines and test chamber until a pressure of 10 pounds per square inch was reached. This condition was maintained for 4 or more hours to passivate

the apparatus completely. This procedure was standard for either gaseous or liquid fluorine. For the liquid-fluorine tests, the reservoir surrounding the test chamber (fig. 3) was filled with liquid nitrogen. Charging the holding tank of known volume with gaseous fluorine to a pressure of 40 pounds per square inch, gave a filled test chamber when the fluorine was liquified.

When the test chamber was filled with liquid fluorine, as described previously, the smooth specimens were loaded to a stress value equal to 90 percent of the yield strength of the material at a temperature of -320° F (liquid-nitrogen boiling temperature). The notch specimens were loaded to 90 percent of the failure stress of duplicate notch specimens in liquid nitrogen. This load was maintained for 2 hours so that the specimens were under stress during the time of exposure to fluorine. After this time, the load was increased until fracture resulted. All specimens were loaded to fracture at strain rates of about 0.005 inch per inch per minute.

After fracture of the specimen, the liquid nitrogen was drained, and the fluorine was valved to a charcoal-filled burner where the fluorine reacted to form harmless byproducts. After the fluorine was consumed, the system was purged with helium gas for at least 1 minute. The test chamber was removed and the entire process repeated for the next specimen.

DISCUSSION AND RESULTS

The use of fluorine in the as-received condition may have influenced the results of this investigation. [The present tests were made with commercially available fluorine that may have contained varying amounts of fluorine compounds. Chemical analysis of the contents of some commercial cylinders, after completion of the tests, indicated as low as 75 percent fluorine with the remainder being hydrogen fluoride, carbon tetrafluoride, oxygen fluoride, carbon dioxide, and so forth.] Consequently, the effects of pure fluorine on the mechanical properties of certain alloys have not been resolved in this investigation. No provision was made to filter out contaminants nor to analyze the fluorine for purity in the individual tests. During the period of testing, a number of fluorine bottles were used; therefore, the contaminants may have varied from one test to the next. Also, contaminants may have been formed during the transfer of the fluorine from the bottles to the test chamber. This could occur if the helium purge did not remove all moisture prior to a specific test. In rocket application, it may be reasonable to assume some contamination is possible because of the complexity of the propellant system. Using the fluorine with contaminants, as in this investigation, is, therefore, believed to be more realistic than using pure fluorine. In reference 3, it was pointed out that the contaminants in the fluorine may greatly intensify reactivity; that is, the higher the percentage of hydrogen fluoride in the fluorine, the more corrosive it becomes. The results of this investigation should, therefore, be qualified as being influenced by the contaminants as well as the fluorine.

Liquid-Fluorine Tests

The tensile-test results of this investigation are tabulated in table II.

The table lists smooth and notch tensile strengths and elongations in liquid fluorine at -320° F. The mechanical properties of the alloys in a noncorrosive environment (liquid nitrogen, -320° F) are also listed. Possible reaction of the fluorine and the contaminants on the alloys was evaluated by comparing these properties as obtained in both test mediums.

The bar graphs in figure 4 show the average percent change in smooth and notch tensile strengths and elongations in liquid fluorine as compared with those in liquid nitrogen. Also shown are the extremes of the data obtained for each material. Most of the alloys investigated show a reduction in smooth tensile strength in the liquid-fluorine environment. The average reduction varies, with the alloy; however, if the least value of reduction is considered for each alloy, the effect of the fluorine environment is essentially negligible. When the scatter of data in both the fluorine and nitrogen environments is considered (table II), the present data indicate a possible trend rather than a conclusive effect.

The degradation of the smooth tensile strength, though, is confirmed by an associated reduction in elongation of most of the alloys. In general, the elongation trends are similar to those indicated for the smooth tensile strength in individual tests. The 70 percent cold-reduced AISI 301 and 304L elongations were omitted from figure 4 because of the low elongations of these alloys (1.0 to 2.0 percent). Consequently, any effect due to fluorine was difficult to ascertain.

Six of the alloys in this study were tested for notch strength, and these showed (fig. 4), at most, a reduction in notch strength of 3 percent in liquid fluorine compared with the notch strength in liquid nitrogen. Any effect of the liquid fluorine on the notch strength is probably overshadowed by the fact that the alloys are notch sensitive because of the low temperature (-320° F) and the sharp-notch radius. There was no evidence of ignition on any of the specimens that were fractured in the liquid-fluorine environment.

(impact sensitivity)

Gaseous-Fluorine Tests

During the course of the present investigation, attention was given to possible ignition of the metal as a result of fracture in gaseous fluorine under flow conditions at ambient temperature (approx. 75° F). In these tests, the test chamber shown in figure 2 was used. The gaseous fluorine was admitted at the side of the chamber. A high-velocity jet of gaseous fluorine was impinged upon the specimen from initial loading to fracture. Using notched specimens allowed directing the jet at the fracture location.

After four specimens were fractured in the gaseous fluorine jet with no evidence of ignition, the scheme was abandoned as a possible ignition test. Of the four specimens, two were AM 350, and two were Ti-6Al-4V. A Chromel-Alumel thermocouple, located adjacent to the notch, indicated no temperature rise. Also, the results of notch strengths in gaseous fluorine compared favorably with the notch strength of alloys in air.

Influence of Contaminants

The surface appearance of the various materials after testing did not usually permit a qualitative approach to determining the deleterious effect of the fluorine. Most of the specimens were stained or were coated with corrosive products, probably because of the impure fluorine used. These products were not necessarily from reactions with the specimens but could have resulted from reactions of other parts of the system such as transfer lines, valves, and so forth. Reference 8 describes in much more detail the effects of impurities in the fluorine.

In view of the variations in mechanical properties with parallel test conditions and the range of surface appearances after testing, the possible reduction in tensile properties in the liquid-fluorine environment may be attributed to contaminants in the fluorine.

In the individual tests, such as that of AM 350, four specimens in liquid fluorine showed maximum variations in smooth tensile strength from -4.4 to 3.6 percent of the average. The liquid-nitrogen smooth tensile strengths also varied; however, the two lowest strengths (272,000 and 270,000 psi) have substantially lower elongations (see table II). The Ti-6Al-4V solution-treated alloy, though, showed a maximum variation in smooth tensile strength from -10.2 to 6.8 percent of the average in the liquid-fluorine environment. In the liquid nitrogen, the alloy showed about ± 2.0 percent variation from the average. The surface appearance of the Ti-6Al-4V alloy was unique. This alloy showed light to heavy granular etching of the surface from immersion in the fluorine (figs. 5(a) and (b)). Figure 5(c) shows the surface of a specimen immersed in liquid nitrogen. At the other extreme, some titanium specimens showed no etching after exposure to liquid fluorine, and the surface appeared clean except for local staining. The photomicrographs associated with figures 5(a) and (c) are representative of the surface and subsurface structure of the specimens after immersion in liquid fluorine and liquid nitrogen. From the photomicrograph in figure 5(a), it appears that the attack is a surface phenomena since no penetration into the grain boundaries is apparent.

SUMMARY OF RESULTS

The short-time exposure of stressed tensile specimens to liquid fluorine indicated deterioration of some mechanical properties when compared with similar tests in a nonreactive environment at the same temperature (i.e., liquid nitrogen, -320° F). This indicated effect is believed due to contaminants. The results are regarded as significant since, in application, fluorine systems may contain contaminants. Detailed results from this investigation are summarized as follows:

1. Exposure of several alloys to liquified commercial fluorine seemed to have a detrimental effect upon the tensile strength of some alloys. A limited number of tests indicated that 2 hours of exposure lowered tensile strengths from insignificant amounts to as much as 11 percent. The elongations showed similar trends.

2. The sharp-notch strengths were not significantly affected.

3. The presence of contaminants could have been the cause of the degradation, and varying amounts might have accounted for the variations in mechanical properties.

4. The surface appearance of specimens exposed to liquid fluorine varied from clean to discolored and etched surfaces had occasional deposits of corrosion products.

Lewis Research Center
National Aeronautics and Space Administration
Cleveland, Ohio, December 14, 1962

REFERENCES

1. Fortini, Anthony, and Huff, Vearl N.: Theoretical Performance of Liquid Hydrogen and Liquid Fluorine as a Rocket Propellant for a Chamber Pressure of 600 Pounds per Square Inch Absolute. NACA RM E56L10a, 1957.
2. Schmidt, Harold W.: Compatibility of Metals with Liquid Fluorine at High Pressures and Flow Velocities. NACA RM E58D11, 1958.
3. Sterner, Charles J., and Singleton, Alan H.: The Compatibility of Various Metals and Carbon with Liquid Fluorine. TR 60-436, WADD, Aug. 1960.
4. Jackson, R. B.: Corrosion of Metals and Alloys by Fluorine. Gen. Chem. Div., Allied Chem. Corp., Mar. 1960.
5. Boyd, W. K.: Summary of Present Information on Impact Sensitivity of Titanium When Exposed to Various Oxidizers. DMIC Memo. 89, Defense Metals Info. Center, Mar. 6, 1961.
6. Kleinberg, Sidney, and Tompkins, James F., Jr.: Compatibility of Liquid Fluorine with Various Metals. Prog. Rep. X, Res. and Dev. Dept., Air Products and Chemicals, Inc., Oct. 1961.
7. Special ASTM Committee: Fracture Testing of High-Strength Sheet Materials. ASTM Bull., Jan. 1960, pp. 29-40.
8. Schmidt, Harold W., and Rothenberg, Edward A.: Some Problems in Using Fluorine in Rocket Systems. Proc. Propellant, Thermodynamics and Handling Conf., Spec. Rep. 12, Eng. Experiment Station, Ohio State Univ., June 20, 1960, pp. 183-202.

TABLE I. - COMPOSITION AND HEAT TREATMENT OF SHEET ALLOYS

Alloy	Thick- ness, in.	Heat treatment	Composition, percent																							
			C	Mn	P	S	Si	Cr	Ni	Mo	V	N	Cb	Ti	Fe	Al	Cu	Mg	Zn	H ₂	N ₂					
AM 350	0.043	1710° F, 1/2 hr; air cool; 100° F, 3 hr; 850° F, 3 hr; air cool	0.10	0.80	-----	-----	0.25	16.50	4.30	2.15	-----	0.10	-----	-----	Bal.	-----	-----	-----	-----	-----	-----	-----	-----	-----	-----	-----
ASM 6434	.030	1600° F, 1/2 hr; oil quench; 500° F, 1 hr; air cool	.35	.74	0.008	0.006	.35	.81	1.75	.31	-----	-----	-----	-----	Bal.	-----	-----	-----	-----	-----	-----	-----	-----	-----	-----	-----
Inconel X	.031	1300° F; aged, 21 hr	.04	.40	-----	.007	.30	15.15	73.0	-----	-----	-----	1.0	2.50	6.80	0.75	0.05	-----	-----	-----	-----	-----	-----	-----	-----	-----
AISI 301	.031	70 percent cold reduce	.10	1.24	.033	.020	.53	17.16	7.28	-----	-----	-----	-----	-----	Bal.	-----	-----	-----	-----	-----	-----	-----	-----	-----	-----	-----
AISI 304L	.031	70 percent cold reduce	.017	1.38	.016	.019	.65	18.18	9.44	-----	-----	-----	-----	-----	Bal.	-----	-----	-----	-----	-----	-----	-----	-----	-----	-----	-----
2014-T6	.125	T6	-----	.80	-----	-----	.80	-----	-----	-----	-----	-----	-----	-----	-----	Bal.	4.4	0.4	-----	-----	-----	-----	-----	-----	-----	-----
6061-T6	.125	T6	-----	-----	-----	-----	.60	.25	-----	-----	-----	-----	-----	-----	-----	Bal.	.25	1.0	-----	-----	-----	-----	-----	-----	-----	-----
7075-T6	.125	T6	-----	-----	-----	-----	-----	.30	-----	-----	-----	-----	-----	-----	-----	Bal.	1.60	2.5	5.6	-----	-----	-----	-----	-----	-----	-----
Ti-6Al-4V	.035	Annealed	.08	-----	-----	-----	-----	-----	-----	-----	-----	4.0	-----	Bal.	.25	6.0	-----	-----	-----	-----	-----	-----	-----	0.015	0.05	
Ti-6Al-4V	.035	Solution (1670° F)	.08	-----	-----	-----	-----	-----	-----	-----	-----	4.0	-----	Bal.	.25	6.0	-----	-----	-----	-----	-----	-----	-----	.015	.05	

TABLE II. - TEST RESULTS OF MECHANICAL PROPERTIES IN LIQUID NITROGEN AND LIQUID FLUORINE

[After exposure for two hours at 90% of yield strength]

Card 5/5

50919

Ni, B, Al, Ti, SS

Alloy	Liquid nitrogen, -320° F			Liquid fluorine, -320° F		
	Smooth tensile strength, ksi	Percent elongation	Notch tensile strength, ksi	Smooth tensile strength, ksi	Percent elongation	Notch tensile strength, ksi
AM 350 ^{SS}	298	21.0	79	262	6.7	76
	293	22.5	104	252	7.0	101
	272	6.0	90	256	7.0	
	270	9.0		242	8.5	
	<u>293</u>	<u>21.0</u>				
	<u>285</u>	<u>15.9</u>	<u>91</u>	<u>253</u>	<u>7.3</u>	<u>88.5</u>
ASM 6434	276	6.8	52.2	271	2.0	
	298		65.2	270	2.1	
	290	4.0		277	2.5	
	<u>276</u>	<u>4.0</u>		<u>274</u>	<u>3.0</u>	
	<u>285</u>	<u>4.9</u>	<u>58.7</u>	<u>273</u>	<u>2.4</u>	
Inconel X ^{Ni, Co}	192	10.7		179	19.0	
	199	18.0		195	21.0	
	<u>189</u>	<u>13.5</u>		<u>192</u>	<u>18.0</u>	
	<u>193</u>	<u>14.1</u>		<u>189</u>	<u>19.3</u>	
AISI 301 70 percent Cr	340	1.5	219	349	1.0	216
	<u>344</u>	<u>1.3</u>	<u>226</u>	---	---	---
	<u>342</u>	<u>1.4</u>	<u>223</u>			
AISI 304L ^{SS}	257		256	240	2.0	250
	253	1.5	254	251	2.0	
	<u>264</u>	<u>1.5</u>				
	<u>258</u>	<u>1.5</u>	<u>255</u>	<u>246</u>	<u>2.0</u>	---
2014-T6 Clad ^{al}	84.0	13.0	56.4	82.0	12.0	58.5
	86.0	14.0	60.7	83.3	12.0	59.7
	83.0	<u>13.5</u>		<u>79.5</u>	<u>11.0</u>	
	<u>84.3</u>	<u>13.5</u>	<u>58.6</u>	<u>81.6</u>	<u>11.7</u>	<u>59.1</u>
6061-T6 Bare	60.6	24.0	55.5	60.2	20.5	58.2
	61.3	22.5	58.7	56.0	16.5	55.5
			54.7	62.0	17.5	
	<u>61.0</u>	<u>23.3</u>	<u>56.0</u>	<u>59.4</u>	<u>18.2</u>	<u>56.9</u>
7075-T6 Clad ^{al}	94.5	14.5	38.7	89.8	10.5	
	94.0	14.0	34.2	93.0	11.0	
	<u>94.0</u>		<u>39.6</u>			
	<u>94.2</u>	<u>14.3</u>	<u>37.5</u>	<u>91.4</u>	<u>10.8</u>	
Ti-6Al-4V ^{Ti} Annealed	207	6.0	183	183	6.5	181
	203	11.0	199	180	6.0	187
	<u>205</u>	<u>11.7</u>	<u>196</u>	---	---	---
	<u>205</u>	<u>9.6</u>	<u>193</u>	<u>182</u>	<u>6.3</u>	<u>184</u>
Ti-6Al-4V Solution treated	226	17.0	----	199	14.0	----
	225	17.0	----	185	7.0	----
	218	14.0	----	208	5.0	----
				220	8.0	
	<u>223</u>	<u>16.0</u>		<u>219</u>	<u>4.5</u>	
				<u>206</u>	<u>7.7</u>	

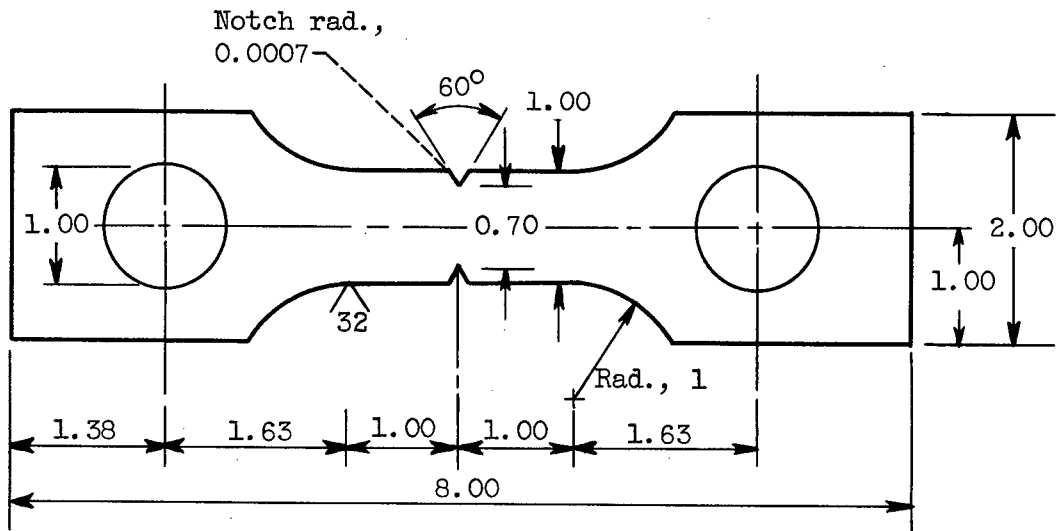

(a) Notch specimen.

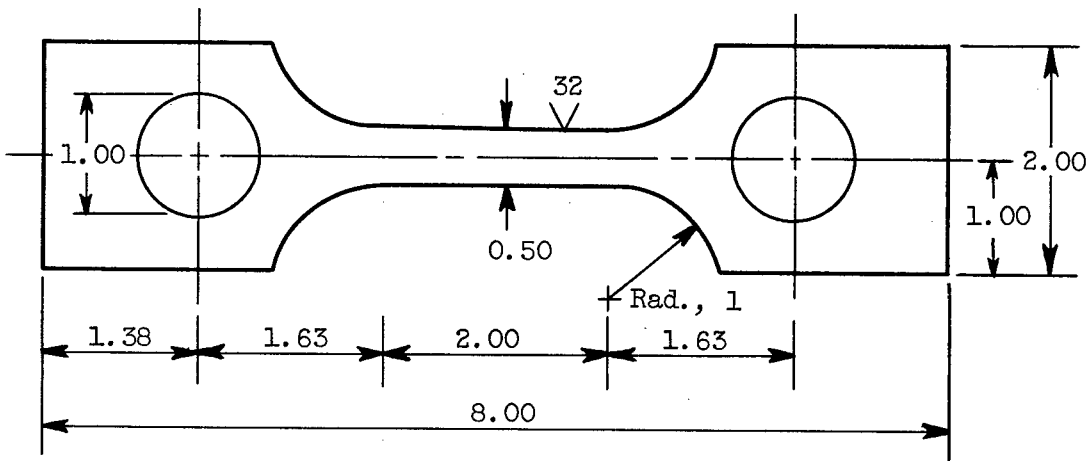

(b) Smooth specimen.

Figure 1. - Smooth and sharp-notch sheet tensile specimens. (All dimensions in inches except as noted.)

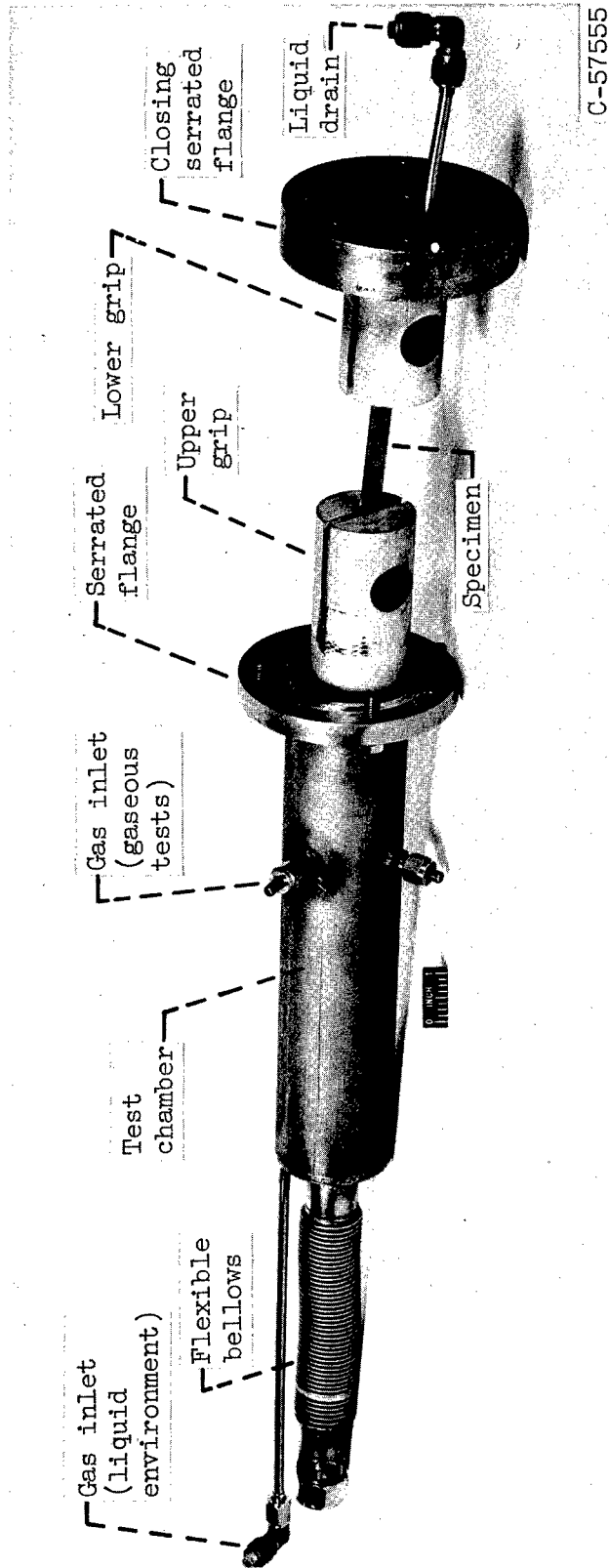
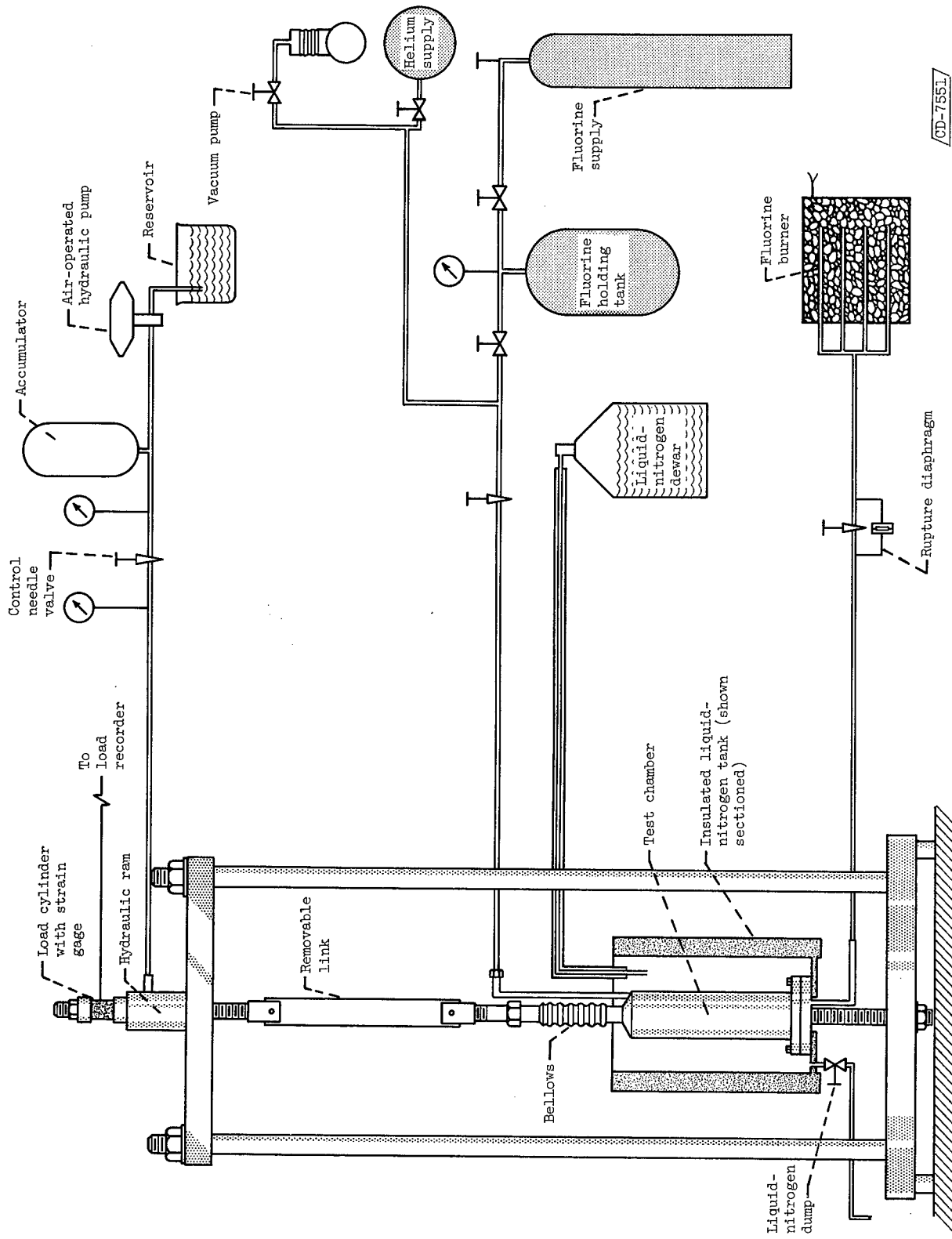

Figure 2. - Exploded view of test chamber and loading fixture for uniaxial tensile data in liquid-fluorine environment.



CD-7551

Figure 3. - Schematic diagram of test setup showing system of loading and gas supply and disposal.

AM 350
 AISI 304L
 ASM 6434
 AISI 301
 2014-T6
 7075-T6
 6061-T6
 Inconel X
 Ti-6Al-4V
 An-nealed
 Solution treated

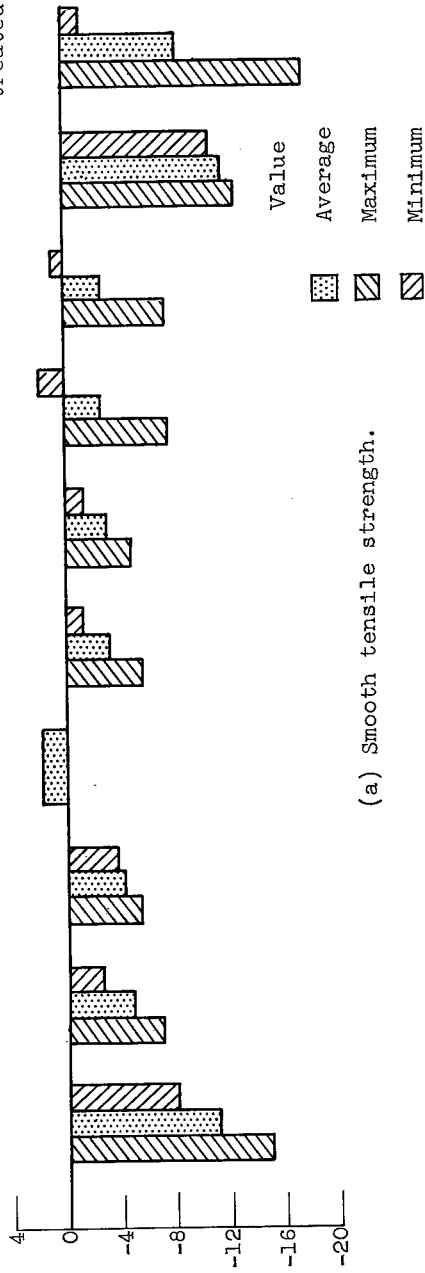

(a) Smooth tensile strength.

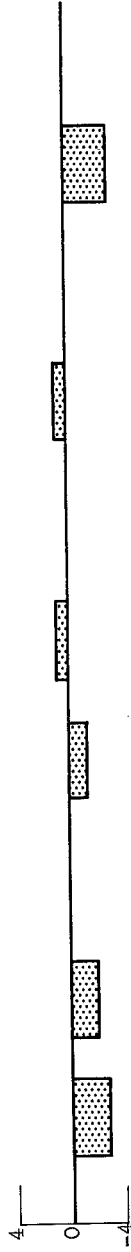

(b) Notch tensile strength.

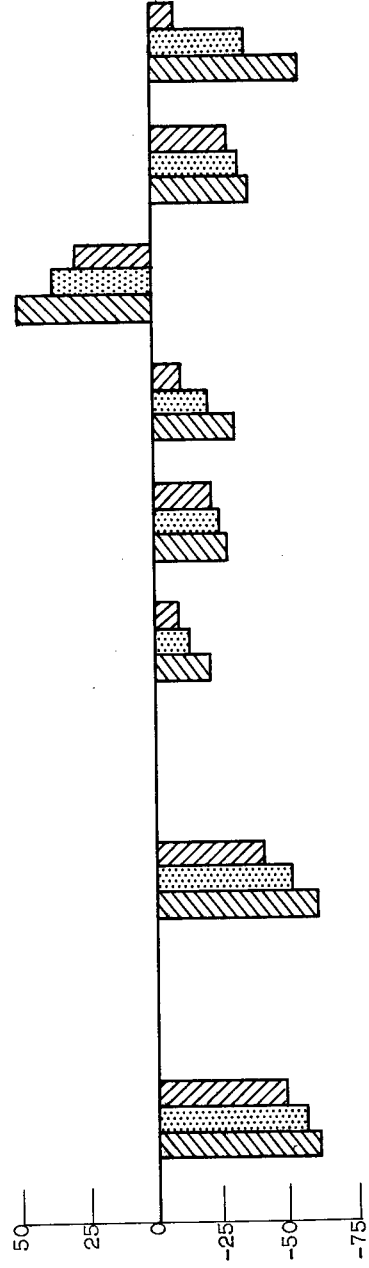

(c) Elongation.

Figure 4. - Percent change of properties in liquid fluorine as compared with those in liquid nitrogen.



Surface

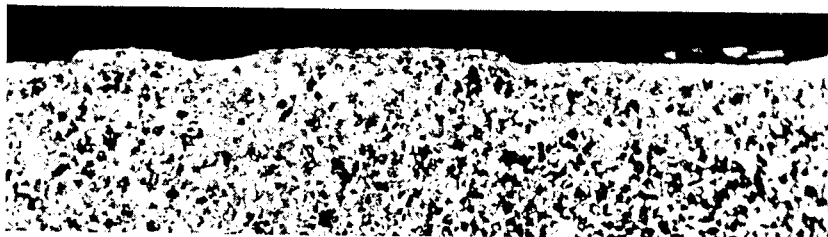

Subsurface microstructure, x250

(a) Liquid fluorine, heavily etched.

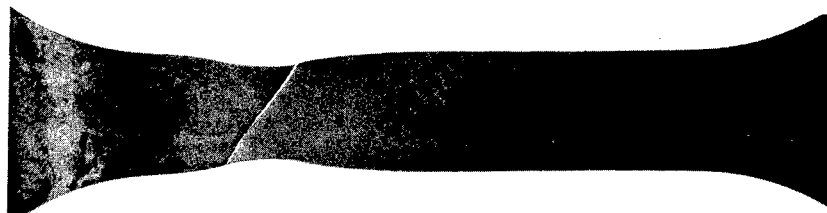

Surface

(b) Liquid fluorine, lightly etched.



Surface

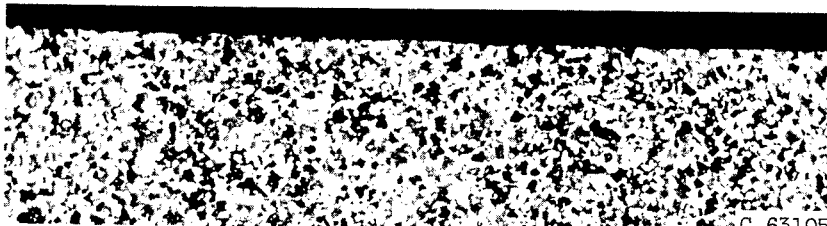

Subsurface microstructure, x250

(c) Liquid nitrogen.

Figure 5. - Comparison of surface and subsurface of Ti-6Al-4V alloy after testing in liquid fluorine and liquid nitrogen (-320° F).

NASA TN D-1706
National Aeronautics and Space Administration.
INFLUENCE OF FLUORINE ENVIRONMENT ON THE
MECHANICAL PROPERTIES OF SEVERAL SHEET
ALLOYS. Hadley T. Richards and Morgan P. Hanson.
April 1963. 14p. OTS price, \$0.50.
(NASA TECHNICAL NOTE D-1706)

Smooth and notch tensile strengths and the elongation of steel, nickel, aluminum, and titanium sheet alloys in liquid nitrogen and in fluorine environments (-320° F) are reported. The effect of fluorine was determined by comparing the mechanical properties in the fluorine environment to those in a liquid-nitrogen environment. Tensile specimens in the fluorine environment were subjected to high stresses for a limited time prior to fracture.

- I. Richards, Hadley T.
- II. Hanson, Morgan P.
- III. NASA TN D-1706

NASA

NASA TN D-1706
National Aeronautics and Space Administration.
INFLUENCE OF FLUORINE ENVIRONMENT ON THE
MECHANICAL PROPERTIES OF SEVERAL SHEET
ALLOYS. Hadley T. Richards and Morgan P. Hanson.
April 1963. 14p. OTS price, \$0.50.
(NASA TECHNICAL NOTE D-1706)

Smooth and notch tensile strengths and the elongation of steel, nickel, aluminum, and titanium sheet alloys in liquid nitrogen and in fluorine environments (-320° F) are reported. The effect of fluorine was determined by comparing the mechanical properties in the fluorine environment to those in a liquid-nitrogen environment. Tensile specimens in the fluorine environment were subjected to high stresses for a limited time prior to fracture.

- I. Richards, Hadley T.
- II. Hanson, Morgan P.
- III. NASA TN D-1706

NASA

NASA TN D-1706
National Aeronautics and Space Administration.
INFLUENCE OF FLUORINE ENVIRONMENT ON THE
MECHANICAL PROPERTIES OF SEVERAL SHEET
ALLOYS. Hadley T. Richards and Morgan P. Hanson.
April 1963. 14p. OTS price, \$0.50.
(NASA TECHNICAL NOTE D-1706)

Smooth and notch tensile strengths and the elongation of steel, nickel, aluminum, and titanium sheet alloys in liquid nitrogen and in fluorine environments (-320° F) are reported. The effect of fluorine was determined by comparing the mechanical properties in the fluorine environment to those in a liquid-nitrogen environment. Tensile specimens in the fluorine environment were subjected to high stresses for a limited time prior to fracture.

- I. Richards, Hadley T.
- II. Hanson, Morgan P.
- III. NASA TN D-1706

NASA

NASA TN D-1706
National Aeronautics and Space Administration.
INFLUENCE OF FLUORINE ENVIRONMENT ON THE
MECHANICAL PROPERTIES OF SEVERAL SHEET
ALLOYS. Hadley T. Richards and Morgan P. Hanson.
April 1963. 14p. OTS price, \$0.50.
(NASA TECHNICAL NOTE D-1706)

Smooth and notch tensile strengths and the elongation of steel, nickel, aluminum, and titanium sheet alloys in liquid nitrogen and in fluorine environments (-320° F) are reported. The effect of fluorine was determined by comparing the mechanical properties in the fluorine environment to those in a liquid-nitrogen environment. Tensile specimens in the fluorine environment were subjected to high stresses for a limited time prior to fracture.

- I. Richards, Hadley T.
- II. Hanson, Morgan P.
- III. NASA TN D-1706

NASA