

REPORT DOCUMENTATION PAGE

AFRL-SR-BL-TR-01-

Public reporting burden for this collection of information is estimated to average 1 hour per response, including the time for reviewing data needed, and completing and reviewing this collection of information. Send comments regarding this burden estimate or air this burden to Department of Defense, Washington Headquarters Services, Directorate for Information Operations and Reports (4302). Respondents should be aware that notwithstanding any other provision of law, no person shall be subject to any penalty for valid OMB control number. PLEASE DO NOT RETURN YOUR FORM TO THE ABOVE ADDRESS.

training the
or reducing
22202-
/ a currently

0023

1. REPORT DATE (DD-MM-YYYY) 01/10/01		2. REPORT TYPE final		3. DATES COVERED (From - To) 01/01/00 - 31/03/01	
4. TITLE AND SUBTITLE Near-Field Microscopy of Polymer Based Nano-Composites				5a. CONTRACT NUMBER	
				5b. GRANT NUMBER f49620-00-1-0226	
				5c. PROGRAM ELEMENT NUMBER 61103D	
6. AUTHOR(S) Dr. David L. Carroll Dr. John Ballato				5d. PROJECT NUMBER 200-2001775	
				5e. TASK NUMBER 3484/US	
				5f. WORK UNIT NUMBER	
7. PERFORMING ORGANIZATION NAME(S) AND ADDRESS(ES) Dr. David L. Carroll Dept. of Physics and Astro. Clemson University Clemson SC 29634				8. PERFORMING ORGANIZATION REPORT NUMBER Dr. John Ballato School of Mat. Sci. and Eng. Clemson University Clemson SC 29634	
9. SPONSORING / MONITORING AGENCY NAME(S) AND ADDRESS(ES) Dr. Charles Y-C. Lee 801 N. Randolph St. Rm 732 Arlington VA 22203-1977					
12. DISTRIBUTION / AVAILABILITY STATEMENT					
AIR FORCE OFFICE OF SCIENTIFIC RESEARCH (AFOSR) NOTICE OF TRANSMITTAL DTIC. THIS TECHNICAL REPORT HAS BEEN REVIEWED AND IS APPROVED FOR PUBLIC RELEASE LAW AFR 130-12. DISTRIBUTION IS UNLIMITED.					
13. SUPPLEMENTARY NOTES					
14. ABSTRACT Advances in functionalization and dispersion mechanics of high aspect ratio nanomaterials such as carbon nanotubes, have given rise to a new class of polymer nanocomposites with anomalously enhanced optical properties in comparison to the intrinsic polymers. Recent absorption and luminescence studies of carbon nanotube composites based on electro-optic polymer hosts such as MEH-PPV, have revealed some of the subtle relationships between nanotube-host interactions and the optical properties of the composite. However, the ability to tailor optical phenomena within these materials requires a more complete model of the effects of the nanotube functionalization and polymer-nanotube charge exchange on the scattering field around the nanostructure. Through this proposal, we intend to extend our current optical studies to include near-field interactions around individual nanostructures embedded in the polymer host.					
15. SUBJECT TERMS					
16. SECURITY CLASSIFICATION OF:			17. LIMITATION OF ABSTRACT	18. NUMBER OF PAGES	19a. NAME OF RESPONSIBLE PERSON David L. Carroll
a. REPORT	b. ABSTRACT	c. THIS PAGE			
				1	

20011220 104

Near-Field Scanning Optical Microscope for the Study of Polymer-Nanotube Interactions

Final Report: Grant Number: 00-1-0226 (DURIP)

Goal: This grant under the DURIP program of AFOSR is intended to establish a near-field scanning probe facility for use in the study of polymer-nanotube interactions. Unique capabilities of this facility will be near-field based spectroscopy including: Raman, absorption and luminescence.

Progress Summary: Working with RHK Inc. and Nanonics Inc., a prototype optical system has been developed and delivered. This has been successfully coupled with a 1.25 m spectrometer from Jobin Yvonne offering impressive line resolution as well as spatial resolution. The system is completely convertible from inverted (transmission NSOM) to reflection NSOM with no inherent instabilities detected. Calibration of the system is currently underway and insertion into ongoing research programs should take place within 2001.

Details: At the current state of development of nano-sciences, high spatial resolution spectroscopy coupled with direct nano-scale imaging has been identified as one of the central needs of the field. Recent calls from DoD and other federal agencies for the establishment of characterization techniques at the nano-scale underscores the need for instrumentation development and characterization. This DURIP is specifically focused at establishing a facility for near-field spectroscopy capable of spatial resolution at 20 nm coupled with optical spectroscopy.

The NSOM scanner itself is based on the Nanonics design that allows both bent tips (AFM normal force feedback) and straight tips (shear force) to be used for imaging. This was chosen to enhance the overall applicability of the device by allowing both, shear or normal forces, to be applied to supported nano-particles. An image of the bent fiber tip is shown in figure 1 (this image is from NANONICS).

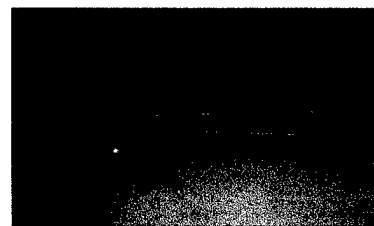

Figure 1: the bent fiber tips from Nanonics allow imaging of nano-particles susceptible to moving under shear force imaging.

The collection optics; objectives, etc., are mounted in a Zeiss optical microscope that can be configured either in an inverted collection mode for transmission NSOM studies or upright for reflected light collection. Generally, the illumination is through-fiber in this system, though other options are possible with a little trouble. Currently, the microscope offers confocal geometries as well, allowing for direct comparisons with near-field spectroscopic characterization.

A general schematic of the spectroscopic setup is shown in figure 2. This systems delivers the collected light through a fiber optic to the 1.25 (0.04 nm resolution) spectrometer. The system is equipped for pulse counting detection using a cooled photomultiplier tube (PMT). Currently the gratings and PMT sensitivity is maximized for red to near-IR detection. Light sources available at the facility include Ar⁺ ion lasers, Ti-Sapphire lasers and a variety of dye lasers. Thus, the instrument has been well designed for recently introduced Gradient Field Raman (GFR) spectroscopy. Hallen et

Figure 2: The setup is quite similar to H. Hallen et al with a couple of notable exceptions. (the figure shown here is a modification of that setup) They include the normal force imaging as well as al. have shown that this spectroscopic technique actually utilizes different transition modes from far field Raman allowing much more local information to be accumulated.

Naturally the issue with NSOM is spatial resolution. In carbon nanotube interactions studies, it is natural to desire a resolution beyond the diameter of the nanotubes. In our cases 20 nm – 40 nm is acceptable with 1.4 nm being ideal. AFM imaging in the instrument can achieve this resolution, however, the actual photon resolution will not be as good.

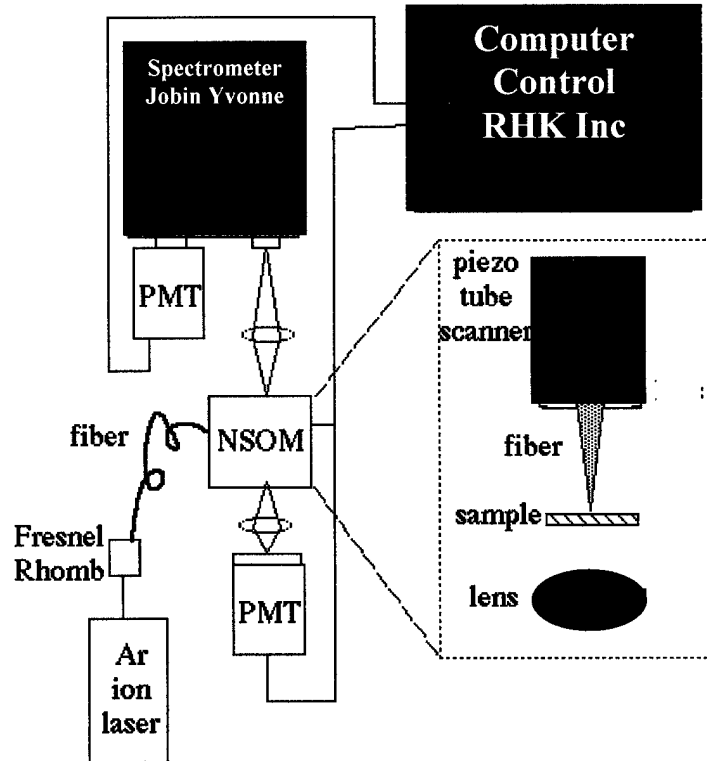

Installation and checkout: The call for bids for the microscope, specifications given above, was approved by the university on 04/01/00. After bids were received and design parameters rechecked, the RHK-NANONICS bid was awarded 05/01/00. Since many parts of this microscope would be a “Special Order” microscope delivery was estimated to be 6 months. Delivery of the microscope was taken on 12/01/00 and setup was arranged for two months following. Several parts were still in development including the optical scaffolding for the collection optics. Final delivery and setup took place on 06/01/01. Total time frame for order and delivery was close to one year. A number of technical factors led to the delay. However, the multi-purpose design of the microscope warranted the delay.

AFM has been demonstrated to resolve multiwalled carbon nanotubes (DIA. 20 nm) with no difficulty. Repeated imaging also shows stability of the supported particles that far exceeds that of the shear force microscopes. Shown in figure 3 is one of the normal force imaging micrographs of MWNTs. There is little problems with tip convolution, suggesting well formed NSOM tips can be fabricated for this type of imaging. The large formation in the image (right) is amorphous carbon from the growth. The nanotube lying across the substrate (lower) is quite long and shows a height of 20 nm.

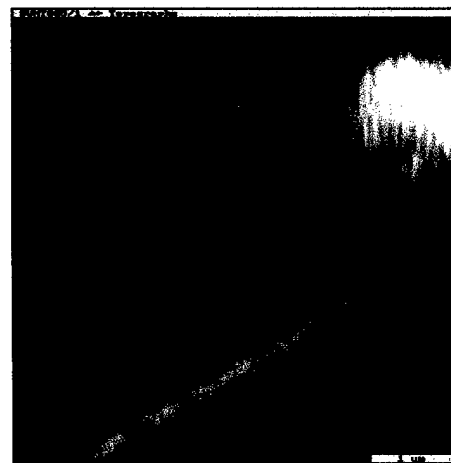

Figure 3: AFM of a MWNT (raw data)

Summary: Clemson University now has an excellent NSOM facility with Raman, absorption and luminescence capabilities. Force feedback resolution of MWNTs and recently SWNT bundles has already been achieved. Tests of the spectrometer and other auxiliary equipment have been performed and all fall within manufacturers specifications.

There are current 3 publications in preparation that credit this instrumentation grant. The instrument will be used on several currently sponsored programs including the AFOSR F49620-99-1-0173.