



Handwritten signature

52656
Handwritten signature

TECHNICAL NOTE
D-1882

DISTRIBUTION STATEMENT A
Approved for Public Release
Distribution Unlimited

AN EXPERIMENTAL INVESTIGATION OF CHEMICAL REACTION
BETWEEN PROPELLANT TANK MATERIAL AND ROCKET
FUELS OR OXIDIZERS WHEN IMPACTED BY SMALL
HIGH-VELOCITY PROJECTILES

By Robert P. Dengler
Lewis Research Center
Cleveland, Ohio

20011221 190

PROPERTY OF:
AERONAUTICAL LIBRARY

NATIONAL AERONAUTICS AND SPACE ADMINISTRATION
WASHINGTON

August 1963

NASA TN D-1882
National Aeronautics and Space Administration.
AN EXPERIMENTAL INVESTIGATION OF CHEMICAL
REACTION BETWEEN PROPELLANT TANK
MATERIAL AND ROCKET FUELS OR OXIDIZERS
WHEN IMPACTED BY SMALL HIGH-VELOCITY
PROJECTILES. Robert P. Dengler. August 1963.
38p. OTS price, \$1.00. (Film suppl. C-222
available on request.)
(NASA TECHNICAL NOTE D-1882)

Tank materials investigated were aluminum, stainless
steel, titanium alloys, and reinforced plastics.
Propellants included liquid oxygen, hydrazine,
unsymmetrical dimethylhydrazine, nitrogen tetroxide,
Arcite 373, and Hercules CLW. Impacts were made
at velocities up to 6500 ft/sec, and the resulting pro-
jectile kinetic energy levels were as high as 959 ft-lb.
Impacts producing complete penetration of the
impacted wall of a titanium tank filled with liquid
oxygen resulted in violent pyrophoric reactions. No
similar interaction of tank wall and contained pro-
pellant occurred in any of the other impacts.

I. Dengler, Robert P.
II. NASA TN D-1882

NASA

NASA TN D-1882
National Aeronautics and Space Administration.
AN EXPERIMENTAL INVESTIGATION OF CHEMICAL
REACTION BETWEEN PROPELLANT TANK
MATERIAL AND ROCKET FUELS OR OXIDIZERS
WHEN IMPACTED BY SMALL HIGH-VELOCITY
PROJECTILES. Robert P. Dengler. August 1963.
38p. OTS price, \$1.00. (Film suppl. C-222
available on request.)
(NASA TECHNICAL NOTE D-1882)

Tank materials investigated were aluminum, stainless
steel, titanium alloys, and reinforced plastics.
Propellants included liquid oxygen, hydrazine,
unsymmetrical dimethylhydrazine, nitrogen tetroxide,
Arcite 373, and Hercules CLW. Impacts were made
at velocities up to 6500 ft/sec, and the resulting pro-
jectile kinetic energy levels were as high as 959 ft-lb.
Impacts producing complete penetration of the
impacted wall of a titanium tank filled with liquid
oxygen resulted in violent pyrophoric reactions. No
similar interaction of tank wall and contained pro-
pellant occurred in any of the other impacts.

I. Dengler, Robert P.
II. NASA TN D-1882

NASA

NATIONAL AERONAUTICS AND SPACE ADMINISTRATION

TECHNICAL NOTE D-1882

AN EXPERIMENTAL INVESTIGATION OF CHEMICAL REACTION
BETWEEN PROPELLANT TANK MATERIAL AND ROCKET
FUELS OR OXIDIZERS WHEN IMPACTED BY SMALL
HIGH-VELOCITY PROJECTILES

By Robert P. Dengler

SUMMARY

High-velocity projectile penetrations of simulated propellant tanks were made to determine the impact sensitivity of tank materials in contact with liquid and solid rocket propellants. Tank materials investigated were aluminum, stainless steel, two titanium alloys, and three reinforced plastics. The propellants included the liquids oxygen, hydrazine, unsymmetrical dimethylhydrazine, and nitrogen tetroxide and the solids Arcite 373 and Hercules CLW. The thicknesses of the impacted tank walls varied from 0.020 to 0.125 inch. The projectiles used for impacts were solid spheres of nylon, aluminum, and steel. The diameter of the spheres for all impacts except one was 0.219 inch, the exception being a 0.062-inch-diameter steel sphere. Impacts were made at velocities as high as 6500 feet per second and at kinetic energies as high as 959 foot-pounds.

Projectile penetration of titanium specimens acting as a wall of a tank containing liquid oxygen caused a chemical reaction between the tank wall and the contained propellant regardless of the material used for the impacting projectile. Violent reactions were initiated by penetrations having kinetic energies as low as 10.4 foot-pounds. Once a reaction was initiated, it propagated vigorously until one of the reactants was consumed. A complete penetration of the titanium tank wall was necessary for a reaction to occur.

All other penetrations of tank materials in contact with the various propellants resulted in no reaction of the tank wall and the contained propellant. Penetration of the simulated rocket casing containing the solid propellant Hercules CLW resulted in the ignition and complete burning of the entire propellant grain.

INTRODUCTION

One of the hazards to space vehicles which is neither well defined nor clearly understood is that associated with meteoroids. The exact danger that exists relative to meteoroids is not known, but, under some conditions.

Reproduced From
Best Available Copy

catastrophic damage to the structure of a space vehicle could probably result from collisions with these hypervelocity particles. A number of investigations of impact damage have been made with target materials being impacted by particles accelerated to high velocities in an attempt to simulate meteoroid impacts (e.g., ref. 1). The preliminary investigation of impacts into solid propellants by small high-velocity projectiles reported in reference 2 indicates that propellant ignition and/or explosive destruction of the rocket motor may result from such impacts. Reference 3 indicates that penetration of liquid-filled tanks by high-velocity projectiles of relatively small size may cause catastrophic fracturing or rupturing of the tank structure. There is also evidence (refs. 4 to 6) that some organic materials (such as the plastics) and titanium alloys are sensitive (chemically reactive) to impact when submerged in liquid oxygen and some other oxidizers that might be used as rocket propellants. The results of references 4 to 6 were obtained from drop tests in which a striker pin in contact with the material specimens was impacted by a plummet. It was not known whether the results of such tests were indicative of the reactions that might occur when high-velocity particles impact propellant tanks filled with such oxidants. In an attempt to better simulate meteoroid impacts into targets in contact with rocket fuels and/or oxidants, an investigation was conducted in which small (0.062- and 0.219-in.-diam.) spherical projectiles impacted model tanks at velocities up to 6500 feet per second. The results are reported herein.

Information published during this investigation indicates that a titanium-oxygen reaction can be initiated by the piercing, puncturing, or high-velocity penetration of a titanium wall of a pressurized tank filled with either gaseous or liquid oxygen (refs. 7 and 8). The results and conclusions of these references are considered and compared with those of this investigation.

In this investigation, a 220 Swift rifle was used to propel solid spheres of nylon, aluminum, and steel into the simulated propellant tanks. The particles were accelerated to velocities ranging from about 756 to 6500 feet per second; the resulting particle kinetic energies ranged from about 4 to 959 foot-pounds. The highest level of energy corresponds to that of a spherical meteoroid having a diameter of 0.018 inch and possessing the greatest density and velocity known for meteoroids. Propellant tank materials investigated for impact sensitivity included aluminum, stainless steel, two titanium alloys, and three reinforced plastics. The tank wall thickness varied from 0.020 inch for the thinnest titanium specimen to 0.125 inch for one of the reinforced plastics. Impacting projectile materials included nylon, aluminum, and steel. The propellants investigated included liquid oxygen, the storable propellants hydrazine, nitrogen tetroxide, and unsymmetrical dimethylhydrazine, and the solid propellant's Arcite 373 and Hercules CIW.

A motion-picture film supplement has been prepared and is available on loan. A request card and a description of the film are given in the back of the report.

APPARATUS AND PROCEDURE

Because of the hazard associated with this type of investigation, much of the testing was conducted in an open area of a remote location. Some tests,

however, were conducted in enclosed test cells so that available facilities could be used for recording various measurements.

Rifle

A 220 Swift rifle was used to propel spherical projectiles of various materials into simulated tanks filled with either solid or liquid propellant. The rifle was mounted on a stand and located about 4 feet from the target tank (fig. 1). The trigger mechanism of the rifle was operated by a solenoid so that the rifle could be fired remotely. For tests conducted in the test cell, the rifle was fired from an adjacent control room, which was separated from the test cell by a thick protective wall. For tests conducted in the remote location, the rifle was fired from behind a protective barrier approximately 120 feet from the test setup. The cartridges used with this rifle were hand loaded with specific amounts of gunpowder, and thus tests were made over a range of projectile velocities. Impact velocities as high as 6500 feet per second were obtained.

Projectiles

The projectiles used for impacting the simulated propellant tanks were solid spheres of nylon, aluminum, or steel having respective densities of 0.042, 0.101, and 0.281 pound per cubic inch. All but one of the impact tests were made with spheres having a diameter of 0.219 inch, which closely approximated the diameter of the rifle bore. One test was made, however, with a 0.062-inch-diameter steel sphere, which required the use of a sabot for firing from this rifle. The sabot was a nylon cylinder 0.22 inch in diameter and length, with an indentation in the center of one end to position the 0.062-inch steel sphere (see inset in fig. 1). The purpose of the sabot deflector plates was to deflect the sabot while allowing the steel sphere to pass between the deflector plates and impact the target tank.

Instrumentation

Velocity measurements. - Projectile velocities for the tests conducted in the test cell were obtained through the use of two capacitor-type sensors located 1 foot apart and connected in a circuit with an electronic event timer. The sensors consisted of a sheet of 0.0025-inch-thick Mylar coated with about 100 angstroms of vapor-deposited aluminum on each side. A potential of 300 volts was applied across the Mylar film, and penetration of the sensor resulted in the shorting of the two layers of aluminum, which in turn allowed a capacitor to discharge through a resistor for triggering the electronic timer. The successive discharge pulses from the penetration of the sensors were used to start, and then stop, the electronic timer. With the time of flight and the distance between the sensors known, projectile velocities were readily calculated.

For tests conducted in the remote location, approximate projectile

velocities were obtained from calibration curves previously determined for this rifle with the use of the velocity measuring equipment previously described. These curves were the result of numerous test shots made with spheres of the various materials and sizes and with varying amounts of gunpowder.

Photographs. - The impacts and/or penetrations of the simulated propellant tanks were recorded photographically to allow the visual study or evaluation of any resulting chemical reactions. The cameras used were capable of photographing at framing rates as high as 6000 frames per second.

Propellant Tanks

The tank materials investigated were an aluminum alloy (6061-T3), a stainless steel (AISI 304), two titanium alloys (5Al-2.5Sn-Ti and 6Al-4V-Ti), and three reinforced plastics (Dacron-fiber-reinforced polyurethane, nylon-cloth-reinforced phenolic resin, and glass-cloth-reinforced epoxy resin). The aluminum and stainless-steel tank walls to be impacted were always 0.031 inch thick; the titanium specimens were 0.020, 0.025, or 0.063 inch thick; and the reinforced plastic specimens were either 0.063 or 0.125 inch thick. The tanks were all cylindrical in shape but varied in size from about 3.5 to 5.5 inches in diameter and from about 6 to 12 inches in length. The tests were conducted with the cylindrical axis of the tank in a horizontal position. All tests (with the exception of those made on the titanium tank containing Hercules CLW) were made with the projectiles impacting an end of the cylindrical tank. The impacted surface or end always constituted the thinnest wall of the tank. When the tank material to be investigated was either aluminum or stainless steel, the entire tank was fabricated from this material with the end or surface to be impacted being welded to the cylindrical portion. This cylindrical portion generally was a length of available tubing. For impacting titanium and reinforced plastic materials in contact with various propellants, a reusable tank was designed that would accommodate tank wall specimens of various materials and/or thicknesses. This special tank or cylinder was fabricated from thick-walled aluminum tubing, and one end was left open (fig. 2). The outside diameter of the open end of the cylinder was threaded to accommodate a retaining nut for securely clamping tank wall specimens.

For the impact tests of the solid propellants, an aluminum or titanium container or cylinder was fabricated from sheet material to conform to the size of the finished propellant grain. The propellant grains were cylindrical in shape and, except for the ends, were coated with a 0.25-inch-thick layer of a rubbery substance known as the inhibitor. The propellant grains were inserted into their respective tanks and bonded to the walls with an epoxy resin to simulate containment in an actual rocket casing.

Propellants

The propellants investigated include the liquids oxygen (lox), hydrazine (N_2H_4), unsymmetrical dimethylhydrazine (UDMH), and nitrogen tetroxide (N_2O_4) and the solids Arcite 373 and Hercules CLW. In general, these propellants can be classified as being one or more of the following: (1) highly reactive, (2) highly toxic, (3) highly corrosive, (4) highly inflammable, or (5) capable

aluminized and considered to be of relatively high specific impulse. Hydrazine, UDMH, and nitrogen tetroxide are classed as economical, reliable, and storable liquid propellants but are highly toxic.

After being filled with liquid propellants, the test tanks were vented to the atmosphere and left unpressurized. At standard atmospheric conditions both nitrogen tetroxide and liquid oxygen have a tendency to either vaporize or boil off. It was, therefore, necessary to complete the testing in as short a time as possible once the tanks were loaded to assure an impact into liquid rather than gaseous propellant. For the tests involving the cryogenic liquid oxygen, the tank was lagged with insulating material to prevent excessive boiloff during test preparations. Figure 3 shows a typical insulated tank on a test stand. The insulation surrounding the test tank was held in place by a wooden frame box approximately 13 inches square. A thin metal sheet was placed over the exposed surface of the insulation to prevent the ignition of the insulation in case a reaction occurred as a result of the impact. To provide additional assurance of an impact into liquid rather than gaseous propellant, the rifle was sighted to effect an impact somewhat lower than the center of the tank end to be impacted.

RESULTS AND DISCUSSION

A complete listing of the impact tests made on simulated propellant tanks including pertinent information and remarks is presented in table I. Although the projectile velocities achieved during these tests are considerably less than those of meteoroids; the energy level is representative, and it is felt that significant conclusions can be made as a result of this investigation.

Aluminum and Stainless-Steel Tanks

Hydrazine. - Impact tests 1 and 2 were made on tanks of either aluminum or stainless steel containing the liquid propellant hydrazine. The tanks were fabricated from either 4-inch-diameter aluminum or $3\frac{1}{2}$ -inch-diameter stainless-steel tubing and appropriately sized end caps, which were welded in place to form closed containers. The thickness of the end cap or surface to be impacted was 0.031 inch for both tanks. The maximum allowable powder charge was used to accelerate a 0.219-inch-diameter steel sphere to a moderately high velocity of about 5800 feet per second. This velocity resulted in a relatively high kinetic energy at impact of about 805 foot-pounds for both tests.

Figure 4 shows the results of the impact on the stainless-steel tank. The steel sphere penetrated the tank wall and left a hole slightly larger (0.253 in.) than the original diameter of the impacting sphere. The impact caused pronounced bulging of the impacted end, which resulted from the extreme pressure forces generated against the tank walls by the shock wave that was formed by the action of the projectile being decelerated in the contained liquid. Reference 5 describes this phenomenon in detail.

The pressure forces generated as a result of the impact on the aluminum

tank were large enough to cause the entire impacted tank end to be explosively detached from the tank. Figure 5 shows some selected frames taken from a movie sequence of the impact. Figure 6 reveals that a complete failure of the welded region, where the end cap was attached to the cylindrical portion of the tank, took place. The hole produced by the steel sphere penetrating the tank wall was somewhat larger (0.301 in.) than that produced in the stainless-steel tank; in addition, a rather pronounced cratering effect was produced around the edges of the penetration; a much greater effect than that on the stainless-steel tank.

In neither impact were there any signs of interaction of the tank wall with the propellant, nor did the movies reveal any evidence of combustion or burning other than the initial flash of light produced at the time of impact (fig. 5). A similar flash of light occurred in the impact on the stainless-steel tank and for all subsequent tank impacts. Impact of the aluminum tank filled with hydrazine also resulted in the formation of a white vapor cloud (fig. 5), presumably from the decomposition of the hydrazine caused by the decompressive forces.

Liquid oxygen. - The tanks used for the liquid-oxygen tests (3 to 5) were of the same size, material, and thickness as those used for the hydrazine tests. With the exception of the propellant being used, the testing conditions were also the same as those of the previous tests. A minor change in the test setup was that the tanks for these tests were lagged with insulating material that was contained by a wooden frame or box similar to that shown in figure 3. No interaction of the tank wall with the propellant took place. In one of the tests on an aluminum tank, the end cap was detached from the tank in about one-third of the welded region that joined it to the cylindrical portion of the tank.

Solid propellants. - Test conditions for the impacts of solid propellants (tests 6 and 7) contained in aluminum cylinders were the same as in the previous test shots. Impact of the simulated rocket casing containing Arcite 373 resulted in a "blowout" in the general area of the impact. Figure 7 shows the impacted tank and reveals the curling and tearing of the 0.031-inch-thick tank wall and the 3/4-inch-diameter hole. The steel pellet penetrated the propellant grain to a depth of about $2\frac{1}{2}$ inches; there were no signs of an interaction between the tank wall and the propellant or evidence of ignition of the propellant itself.

The impact made on the simulated rocket casing containing the Hercules CLW propellant resulted in ignition of the propellant, the entire grain being consumed in flames. Figure 8(a) shows some frames taken from the movie sequence before, at, and after the impact. Figure 8(b) shows selected frames from a movie sequence of the same impact taken with another camera at a different angle and at times later than those indicated in figure 8(a). When the propellant was ignited by the impact, it acted much like a rocket motor exerting a thrust and lifted the tank off the test stand. The propellant apparently burned through to the other end of the grain, and flames shot out from both ends of the container. In the case of the solid propellants, no end cap was used for the rear or back end of the tank since the grain was bonded with an epoxy resin to the cylindrical portion and the front end cap. The pressures generated by the impact caused the impacted end cap to fracture in a catastrophic manner, the resulting pieces

being scattered about the immediate area.. The third frame of figure 8(a) (7 msec after impact) shows some of the pieces of the end cap being explosively detached from the tank. Figure 9 shows the extensive damage that resulted from the impact; the tearing or curling of the impacted surface resulted in the ultimate failure of the welded region joining the end cap to the cylinder. Despite the generally violent physical and chemical reactions, there were no signs of a specific interaction of the impacted end cap with the propellant.

Titanium Tanks

Liquid oxygen. - Impact tests 8 to 30 involved titanium tank walls in contact with liquid oxygen. The impacts covered a range of test conditions with nylon, aluminum, and steel spheres being accelerated to velocities between 756 and 6500 feet per second, which produced kinetic energies between 4.9 and 805 foot-pounds. All but a limited number of the impacts initiated an interaction of the titanium and liquid oxygen that resulted in a violent explosive and/or pyrophoric reaction. The exceptions are discussed further in subsequent paragraphs. Figure 10 presents selected frames of a movie sequence that is typical of the violent titanium - liquid-oxygen reaction that occurred when impacts were made on the two titanium alloys investigated (5Al-2.5Sn-Ti and 6Al-4V-Ti). A number of flareups or violent releases of energy such as that shown at 84 milliseconds after impact were common to all the impacts that resulted in this type of reaction. The last frame of this figure shows that the vigorous burning had subsided and almost ended only 1.5 seconds after impact. Once the burning or chemical reaction was initiated in these tests, it continued vigorously until all the exposed titanium was consumed and there remained only an annulus portion that was held in place by the retaining nut (fig. 11).

Impacting projectile material: The first impact of a titanium tank wall was made with a 0.219-inch-diameter steel sphere at a velocity of 5800 feet per second. The condition of the tank after the impact and the subsequent titanium - liquid-oxygen reaction is shown in figure 12. Molten titanium, produced during the violent reaction that resulted, deposited on the retaining nut and the inside of the tank and caused the damage shown in the figure. The insulation that surrounded the tank was slightly scorched as a result of the vigorous burning, and for all subsequent tests the insulation was covered with a thin stainless-steel sheet to prevent such damage.

Other impacts were made on tank walls of titanium by using spheres of nylon and aluminum as the impacting projectiles in order to determine whether the projectile material was a factor in causing the reaction. For many of these tests, the tanks were electrically grounded, one end of a copper lead wire being attached to the tank and the other end to a metal rod into the ground. This was done to eliminate the possibility of an electrostatic potential being set up between the tank and its contents and the ground proper as a result of the impact and thereby causing a reaction. From these tests it was found that the impacts still produced a violent reaction regardless of the projectile material used for impact and whether or not the tank was grounded.

Impact energy level: A number of impacts were made in an effort to estab-

lish whether there was a critical energy level of impact required to initiate a reaction and also to determine whether an impact of the titanium wall without a penetration would result in a violent reaction. The titanium specimen shown in figure 13 was impacted twice by 0.219-inch-diameter nylon spheres (tests 15 and 16) without a reaction occurring. The indentation from test 15 was produced by an impact at an energy of 36.7 foot-pounds, the projectile velocity being 3200 feet per second. The impact resulted in very fine hairline cracks at the base of the indentation. The other indentation was produced by a nylon sphere having a kinetic energy of 46.5 foot-pounds at a velocity of 3600 feet per second. Figure 13(b) shows the side of the titanium wall that was exposed to the liquid oxygen, and, as can be seen, the impact of test 16 opened a crack about 3/16 inch long, from which liquid oxygen spurted profusely. The impact had exposed a fresh titanium surface to the liquid oxygen, but no reaction occurred.

Impacts with nylon spheres at somewhat higher kinetic energies, such as 76 foot-pounds, could be expected to result in a penetration of the titanium tank wall. An impact made at this energy level (test 14), along with others at slightly higher energy levels, resulted in the violent type of pyrophoric reaction discussed previously. Empirical equations for the penetration of thin metal sheets by high-speed particles (as presented by Malick in the "Proceedings of the Third Symposium on Hyperimpact") show that the penetration depends upon several variables, one being the material density of the impacting particle. These equations indicate that a titanium wall of given thickness could be penetrated at a much lower kinetic energy with spheres of aluminum than with nylon spheres of the same size. The respective densities of nylon and aluminum are 0.042 and 0.101 pound per cubic inch. Impacts on simulated titanium tanks with the heavier aluminum projectiles were made at an energy level as low as 4.9 foot-pounds, but no reaction was observed because the projectiles did not penetrate the test specimen (tests 20, 22, and 23). A violent reaction was obtained at an impact level of 10.4 foot-pounds (test 21) when the aluminum projectile penetrated the test specimen.

Impacts (tests 25 and 26) were also made with a thicker titanium tank wall (0.063 in.). An impact by a nylon sphere (test 25) at an energy level of 76 foot-pounds resulted in a slight dent in the titanium wall, whereas an impact and/or penetration by an aluminum sphere with a kinetic energy of 82 foot-pounds resulted in a violent reaction. From the results of these and other test shots previously discussed, it was concluded that the initiation of an interaction of the titanium wall with the liquid oxygen contained in the tank did not depend on any critical energy level of impact. Instead, it appears that the initiation of a reaction depended on a specific velocity, which had to be great enough to cause a projectile of a specific material to at least completely penetrate the titanium wall. These tests strongly indicate that, every time a titanium tank filled with liquid oxygen is completely penetrated, a violent reaction will result and propagate until one of the reactants (titanium or liquid oxygen) is consumed.

Heat generated at impact: Unpublished NASA data reveal that high-velocity impacts (of the energy level investigated herein) on aluminum tanks filled with water can generate sufficient heat to anneal the aluminum in the immediate area

of the impact or penetration. Hardness tests made on the impacted aluminum end indicated that the heat-affected zone was confined to a distance of about 0.062 inch from the edges of the hole left by the impact, the hole being only slightly larger than the original projectile diameter. Since the physical properties of titanium alloys are such that they have particularly low thermal conductivities and heat capacities, the heat generated at impact would be dissipated more slowly than in aluminum and could result in higher local temperatures. Impact tests 27 to 29 were made in an attempt to determine whether the heat generated at impact in the previous titanium - liquid-oxygen tests caused the ignition of the titanium. These tests were conducted with titanium specimens having prepunched holes large enough so that the titanium metal was remote from the point of impact or heat-affected zone.

Test 27 was conducted by using a titanium specimen with a 1-inch-diameter prepunched hole at the center (fig. 14). A 0.006-inch-thick sheet of aluminum foil was placed over the titanium disk, with both the aluminum and titanium being held in place by the retaining nut of the tank. This allowed the tank to be filled with liquid oxygen. The rifle was bore sighted to impact at the center of the prepunched hole, which was outlined in the thin aluminum foil. Impact by a steel sphere produced the results shown in figures 14(b) and (c). The aluminum foil ruptured and peeled back on itself (fig. 14(b)) as a result of the pressure forces generated in the liquid oxygen by the impact and penetration of the high-velocity sphere. It can be seen that the titanium test specimen was not consumed by any violent reaction with the liquid oxygen. It was noted, however, that on the reverse side of the specimen (fig. 14(c)) some slight reaction did occur in several areas of the specimen.

Two subsequent tests (28 and 29) were made with titanium specimens having 9/16-inch-diameter prepunched holes, again covered with a thin sheet of aluminum foil. In both of these tests the impact initiated violent reactions that consumed all the titanium and aluminum specimens except the portions protected by the retaining ring.

It was apparent from these tests that the actual striking or impacting of the titanium surface itself was not necessary to initiate a reaction. In addition, it was concluded that the heat generated at impact was not the cause for igniting the titanium in these tests. Reference 3 indicates that a strong shock wave is generated within tanks containing water when a high-velocity particle pierces the tank wall and travels into the water. This reference points out that the pressures generated as a result of the shock wave are extremely high (in excess of 100,000 psi) in the immediate area of the impact or penetration but decay rapidly with distance as the shock wave propagates away from the point of impact. Inasmuch as the kinetic energies of the impacting particles for the tests reported in reference 3 and herein were of the same order, the pressures generated can reasonably be assumed to have been of similar magnitude, even though the liquid impacted was oxygen rather than water. The liquid pressures exerted on the titanium disks with the smaller holes (9/16-in. diam.), then, would certainly have been greater than those sustained by the disk with the larger hole (1-in. diam.). Since no sustained reaction took place in the test of the titanium disk with a 1-inch hole, and since violent reactions did result when titanium disks with 9/16-inch holes were used, it would appear that the

pressures acting on the tank wall as a result of the shock wave created in the liquid and/or the resulting high-velocity flow of oxygen over the titanium surfaces may be primary factors in the initiation of these violent titanium - liquid-oxygen reactions.

Impacting projectile size: The titanium - liquid-oxygen impact test 30 was made in order to determine whether or not an impact by a smaller particle could affect a violent reaction. A 0.062-inch-diameter steel sphere was used for the impact and was accelerated to a velocity of about 5200 feet per second, which resulted in a kinetic energy of about 15 foot-pounds at impact. A violent reaction occurred as a result of this impact. The most obvious conclusion to be drawn from this test is that impacting-particle size, at least for spheres as small as 0.062 inch in diameter, is not a factor in the initiating of the titanium - liquid-oxygen reaction.

Visual recordings of impacts: As an aid to further the study of the titanium - liquid-oxygen reaction, high-speed movies (with framing rates up to 6000 frames per sec) were taken of particle impacts and ensuing reactions. These movies do not indicate the source or the cause of the reaction between titanium and liquid oxygen, but they do show that the reaction produced is by no means in a steady-state condition. The quasi-steady-state burning of the titanium is interrupted periodically by a number of flareups, explosions, or sudden releases of energy. As many as five violent flareups were detected in one of the movies. The movies also reveal that, once the reaction is started, it becomes highly exothermic and provides ample heat for sustaining the reaction until either the test specimen is consumed or the supply of oxygen is exhausted.

Oxidation of metals in the presence of liquid oxygen is not normally a problem because oxygen is relatively inert in the liquid state. In addition, titanium, under normal conditions or usage, resists oxidation very well. This oxidation resistance is largely attributed to the formation of a protective oxide at the surface that inhibits further oxidation. Reference 6 points out, however, that the oxides produced by a titanium - liquid-oxygen reaction are highly soluble in molten titanium and would diffuse rapidly at the reacting surface and thereby allow fresh titanium to be exposed for further reaction. It seems quite reasonable then that, once a reaction has been initiated, it can proceed or propagate with little or no retardation from the oxides formed.

Comparison with other investigations: Tests reported in references 7 and 8 indicate that titanium-oxygen reactions can be initiated by the piercing, puncturing, or penetration of a titanium wall of a pressurized tank filled with either gaseous or liquid oxygen. The testing methods involved both the drop-weight type of apparatus with a falling sharp tool and an explosive-charge technique for accelerating small steel disk-shaped projectiles to high velocities for impacting and penetrating the tanks. The tests conducted with the explosive-charge technique, however, often resulted in a splattering or fragmenting type of impact. Nevertheless, the types of reactions produced by these tests were generally very similar to those reported herein. The propagation of the titanium-oxygen reaction, however, was not nearly as complete or extensive as for the impact tests of this investigation. A possible explanation may be that the supply of oxygen was exhausted and therefore insufficient to support further oxidation.

From the drop-weight puncture tests of reference 7, it was concluded that the rate of incidence of severe burning reactions increases directly with increased initial pressurization of the oxygen, but a minimum pressure threshold below which the reaction was not initiated was not found.

In both this investigation and those of references 7 and 8, no reactions took place when small high-velocity projectiles impacted the titanium wall in contact with oxygen without completely penetrating the wall. There is also agreement that there do not appear to be significant differences in the reactions produced with the two titanium alloys investigated herein (5Al-2.5Sn-Ti and 6Al-4V-Ti).

Methods investigated in reference 7 to retard or inhibit the reactions by coating the titanium specimens with aluminum foil, aluminum from dipping, vapor-deposited aluminum, or electrodeposited copper, nickel, gold, or silver were generally ineffective.

The results of many tests by various methods at the NASA Marshall Space Flight Center reveal that there are at least four ways to initiate titanium-oxygen reactions: impact, shock, puncture, and spark (unpublished data).

Nitrogen tetroxide. - Two impact tests were conducted on simulated titanium tanks filled with nitrogen tetroxide. The tests involved impacts by both an aluminum sphere and a steel sphere having a diameter of 0.219 inch. Both impacts were made with the maximum obtainable velocity for the respective spheres. In both cases, the impacts resulted in penetration and pronounced bulging of the impacted titanium wall, but no ignition or chemical reaction occurred as a result of either impact (fig. 15). In the case of the impact with the steel sphere, the bulging was more pronounced; the titanium disk was torn at the outer edge where the disk was forced out from under the retaining nut of the tank. The hole produced by the steel sphere was about 0.230 inch in diameter, while the aluminum sphere produced a much larger hole, about 0.285 inch in diameter. The spheres used for these impacts were recovered after the tests, and the deformation of the spheres due to impacting the titanium wall is revealed in the figure. The less-dense aluminum sphere shows considerable deformation, which resulted in producing the larger hole.

Unsymmetrical dimethylhydrazine. - An impact of a simulated titanium tank filled with the liquid propellant UDMH was made by using a 0.219-inch-diameter steel sphere at the maximum velocity condition for this rifle. The results of the impact were similar to those that occurred in the titanium - nitrogen tetroxide tests just described.

Hercules CLW. - Impact tests 34 to 36 were made on a grain of Hercules CLW propellant encased in a 0.020-inch-thick titanium (5Al-2.5Sn-Ti) shell. Including the 0.25-inch thickness of the inhibitor, the grain diameter was about 3.75 inches. As in all other tests, the tank was mounted so that the cylindrical axis was in a horizontal position; however, the impacts were made on the cylindrical surface of the tank rather than on the tank end. Thus, the impacting particle would have to penetrate the inhibitor as well as the titanium shell before impacting the propellant.

These tests were intended (1) to determine whether any chemical reaction between the tank material and the propellant would occur as a result of an impact and (2) to determine the approximate level of kinetic energy required for an impacting particle to ignite the propellant. The very low kinetic energy (17.3 ft-lb) of impact test 34 resulted in the sphere merely denting the titanium casing. In impact test 35 (53.8 ft-lb) the 0.219-inch steel sphere penetrated the titanium shell and embedded in the inhibitor to a depth of about 3/16 inch. Impacting the tank with a steel sphere possessing a kinetic energy of 95.4 foot-pounds resulted in ignition of the propellant (test 36). Figure 16 shows the results of this test. Although the tank ruptured as a result of the pressures generated from the impact and the propellant burned completely, there was no evidence of any chemical reaction between the titanium tank material and the propellant itself. As can be seen in the figure, a pool of molten aluminum had deposited on the support member to which the tank was mounted. Aluminum is one of the ingredients of this propellant. It appears that the propellant will ignite as a result of an impact when the projectile has sufficient energy to completely penetrate the inhibitor.

Reinforced Plastic Tanks

An increased interest has been generated in utilizing reinforced plastics as propellant tanks for space or missile applications because of their high strength-to-weight ratio as compared with some of the commonly used metals. Standard drop tests of reference 6, however, indicated that plastics, in general, exhibit impact sensitivity when submerged in liquid oxygen. Three types of reinforced plastics were used for the impact tests of simulated tanks filled with liquid oxygen: namely, nylon-cloth-reinforced phenolic resin, Dacron-fiber-reinforced polyurethane, and glass-cloth-reinforced epoxy resin. On a weight basis, these filament-reinforced plastic materials were about 80 percent filament material and 20 percent polymeric binding material.

The same type of special tank design as used for the titanium impact tests was used for impacts on tank walls of reinforced plastic. All impacts on reinforced-plastic walls were made with 0.219-inch-diameter steel spheres having velocities between 6230 and 6330 feet per second, which resulted in kinetic energies between 929 and 959 foot-pounds.

Impacts made on two simulated glass-cloth-reinforced epoxy resin tank walls in contact with liquid oxygen resulted in mere penetrations of the specimens with no sustained burning or chemical reaction (fig. 17). The plastic or glass cloth fibers at the edges of the penetration have a dark appearance, which indicates that singeing may have taken place. In the area surrounding the hole left by the impact, a stress pattern approximately a diamond shape was produced. Other evidence of high stress appears toward the outer edges of the disk, that is, where the specimen was secured by the retaining nut.

Impacts on both the nylon-cloth-reinforced phenolic-resin specimen and the Dacron-fiber-reinforced polyurethane specimen resulted in catastrophic fracturing of the impacted wall, as shown in figures 18 and 19. The failure of the phenolic tank wall is representative of a brittle fracture, whereas the failure

of the polyurethane tank wall was more typical of a rupture of a flexible material. Neither impact resulted in any burning or chemical reaction; however, it was noted that a darkened appearance existed around the edges of the impact point of the polyurethane specimen, similar to that from the impacts on the glass-cloth - epoxy-resin specimens. All specimens were impacted at particle energy levels above 900 foot-pounds, and no chemical reaction resulted. Reference 6 reports that plastics, similar to those used as the binder in the reinforced plastic materials investigated herein, were impact sensitive to liquid oxygen under drop test conditions at energy levels of only 80 foot-pounds. It might be expected that the glass-reinforced material investigated (consisting of only 20 percent organic plastic material) might be less impact sensitive in a liquid-oxygen environment than the other materials, in which the reinforcing fibers as well as the binder were organic materials. For the energy levels investigated herein, no conclusions relative to this possibility could be made, but it is of interest to note that small high-velocity particle penetrations into materials that were 100 percent polymeric did not cause reactions with liquid oxygen even though the kinetic-energy levels were much higher than those employed in reference 6. It would seem that, based on the results of reference 6 and those obtained herein, the impact mode plus the size, velocity, and/or shape of the impacting particle may affect the reactivity of polymeric materials in the presence of liquid oxygen.

SUMMARY OF RESULTS

The results of an investigation of high-velocity impacts and penetration of specimens simulating a tank wall or rocket casing in contact with various propellants can be summarized as follows:

1. Impacts resulting in the complete penetration of titanium specimens in contact with liquid oxygen caused a violent explosive and/or pyrophoric reaction between the titanium and the liquid oxygen. This reaction continued until all the titanium exposed to the liquid oxygen had been consumed.
2. Regardless of the impacting projectile material or size, a titanium - liquid-oxygen reaction resulted when the projectile velocity was large enough to produce a complete penetration of the tank wall. No reactions were obtained when the high-velocity projectiles did not completely penetrate the titanium wall.
3. Projectile impacts directed through the hole of a prepunched titanium tank wall (covered with thin aluminum foil to contain the oxygen) also resulted in a reaction between the titanium and the liquid oxygen.
4. No interaction between liquid oxygen and the test specimens was obtained when the specimen or impacted tank wall was aluminum, stainless steel, or reinforced plastic having glass, Dacron, or nylon filaments.
5. No chemical reaction between test specimens of aluminum or stainless steel and hydrazine was obtained.

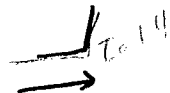
T. C. 14

6. No chemical reaction between titanium specimens and unsymmetrical dimethylhydrazine or nitrogen tetroxide was obtained.

7. No chemical reaction occurred between Arcite 373 and aluminum or between Hercules CLW and either aluminum or titanium. In the case of the Hercules CLW propellant, however, high-velocity projectile impacts ignited the propellant.

Lewis Research Center
National Aeronautics and Space Administration
Cleveland, Ohio, May 9, 1963

end
tap 16
in table

REFERENCES

1. Herrmann, Walter, and Jones, Arfon H.: Survey of Hypervelocity Impact Information. Rep. 99-1, Aeroelastic and Structures Res. Lab., M. I. T., Sept. 1961.
2. Carter, David J., Jr.: A Preliminary Investigation on the Destruction of Solid-Propellant Rocket Motors by Impact from Small Particles. NASA TN D-442, 1960.
3. Stepka, Francis S., and Morse, C. Robert: Preliminary Investigation of Catastrophic Fracture of Liquid-Filled Tanks Impacted by High-Velocity Particles. NASA TN D-1537, 1963.
4. Hauser, R. L., Sykes, G. E., and Rumpel, W. F.: Mechanically Initiated Reactions of Organic Materials in Missile Oxidizers. TR 61-324, Aero. Systems Div., Oct. 1961.
5. Reynales, C. H.: Compatibility of Materials with Oxygen. Rep. D81-444, Douglas Aircraft Co., Inc., Oct. 1958.
6. Jackson, J. D., Miller, P. D., Boyd, W. K., and Fink, F. W.: A Study of the Mechanism of the Titanium-Liquid Oxygen Explosive Reaction. TR 61-479, Aero. Systems Div., Sept. 1961.
7. Chafey, J. E., Witzel, W. E., and Scheck, W. G.: Titanium-Oxygen Reactivity Study. AE62-0674, General Dynamics/Astronautics, July 2, 1962.
8. Rolsten, R. F., Hunt, H. H., and Wellnitz, J. N.: Hypervelocity Impact on Pressurized Structures (Pt. 1), AE62-0207, General Dynamics/Astronautics, Jan. 31, 1962.

Al, SS, Ti, Com

52656

CARD 9/7

TABLE I. - HIGH-VELOCITY IMPACT TESTS ON SIMULATED PROPELLANT TANKS

Test	Tank wall material	Tank wall thickness, in.	Propellant (a)	Projectile material (b)	Projectile velocity, ft/sec	Projectile kinetic energy, ft-lb	Remarks
1	304 Stainless steel	0.031	Hydrazine	Steel	C5800	805	No interaction; pronounced bulging of wall
2	Aluminum	.031	Hydrazine	Steel	C5800	805	No interaction; end cap completely detached
3	Aluminum	.031	lox	Steel	C5800	805	No interaction; pronounced bulging of wall
4	304 Stainless steel	.031	lox	Steel	C5800	805	No interaction; pronounced bulging of wall
5	Aluminum	.031	lox	Steel	C5800	805	No interaction; end cap partially detached
6	Aluminum	.031	Arcite ^{SS} 373	Steel	C5800	805	No interaction; sphere embedded in propellant grain
7	Aluminum	.031	Hercules ^{SS} CLW	Steel	C5800	805	No interaction; propellant ignited and burned completely
8	dTitanium	.025	lox	Steel	C5800	805	Violent reaction
9	dTitanium	.025	lox	Nylon	C6500	152	Violent reaction
10	dTitanium	.025	lox	Aluminum	e2915	73	Violent reaction
11	dTitanium	.025	lox	Nylon	C1100	4.3	No reaction; slight dent in wall
12	dTitanium	.025	lox	Nylon	C2000	14.4	No reaction; dent and crack produced in wall
13	dTitanium	.025	lox	Nylon	C3600	46.5	No reaction; fine cracks in wall with lox squirting out
14	dTitanium	.025	lox	Nylon	C4600	76.0	Violent reaction
15	dTitanium	.025	lox	Nylon	C3200	36.7	No reaction; slight dent in tank wall
16	dTitanium	.025	lox	Nylon	C3600	46.5	No reaction; crack in tank wall; lox squirting out
17	dTitanium	.025	lox	Nylon	C5445	106	Violent reaction
18	dTitanium	.025	lox	Nylon	C5815	121	Violent reaction
19	dTitanium	.025	lox	Nylon	C5200	96	Violent reaction
20	dTitanium	.025	lox	Aluminum	C756	4.9	No reaction; dent in tank wall
21	dTitanium	.025	lox	Aluminum	C1100	10.4	Violent reaction
22	dTitanium	.025	lox	Aluminum	e832	5.9	No reaction; dent in tank wall

	0.025	lox	Aluminum	944	7.7	No reaction; dent and cracks in tank wall
23	d Titanium	lox	Aluminum	C944		No reaction; dent and cracks in tank wall
24	d Titanium	.025 lox	Aluminum	C1312	14.8	Violent reaction
25	d Titanium	.063 lox	Nylon	C4600	76	No reaction; dent in tank wall
26	d Titanium	.063 lox	Aluminum	C3100	82	Violent reaction
27	d Titanium	.025 lox	Steel	C5800	805	1-in. prepunched hole covered with aluminum foil; very limited re-action
28	d Titanium	.025 lox	Aluminum	C6400	352	9/16-in. prepunched hole covered with aluminum foil; violent reaction
29	f Titanium	.020 lox	Aluminum	C6400	352	9/16-in. prepunched hole covered with aluminum foil; violent reaction
30	f Titanium	.020 lox ^{all}	Steel	C5200	15	Violent reaction
31	f Titanium	.020 Nitrogen tetroxide	Steel	C5800	805	No reaction; penetration of tank wall with pronounced bulging
32	f Titanium	.020 Nitrogen tetroxide	Aluminum	C6400	352	No reaction; penetration of tank wall with pronounced bulging
33	f Titanium	.020 UDMH ^{all}	Steel	C5800	805	No reaction; penetration of tank wall with pronounced bulging
34	d Titanium	.020 Hercules	Steel	C850	17.3	Slight dent in casing
35	d Titanium	.020 CLW	Steel	C1500	53.8	Projectile embedded in inhibitor and casing
36	d Titanium	.020 Hercules	Steel	C2000	95.4	Propellant ignited, but no reaction with tank wall
37	Glass-cloth epoxy resin ^{com}	.125 lox	Steel	C6330	959	No reaction; penetration of tank wall
38	Glass-cloth epoxy resin ^{com}	.125 lox	Steel	C6230	929	No reaction; penetration of tank wall
39	Nylon-cloth phenolic resin ^{com}	.125 lox	Steel	C6250	935	No reaction; catastrophic rupture of tank wall
40	Dacron-fiber polyurethane ^{com}	.125 lox	Steel	C6250	935	No reaction; catastrophic rupture of tank wall

^aLiquid oxygen, lox; unsymmetrical dimethylhydrazine, UDMH.

^bAll projectiles were 0.219-in.-diam. spheres except for that used in test 30 (0.062 in.).

^cApproximate velocity.

^d5Al-2.5Sn-Ti.

^eMeasured velocity.

^f6Al-4V-Ti.

^g1/16-in.-diam. sphere.

all, 55, T, com

52656

CARD 7/7

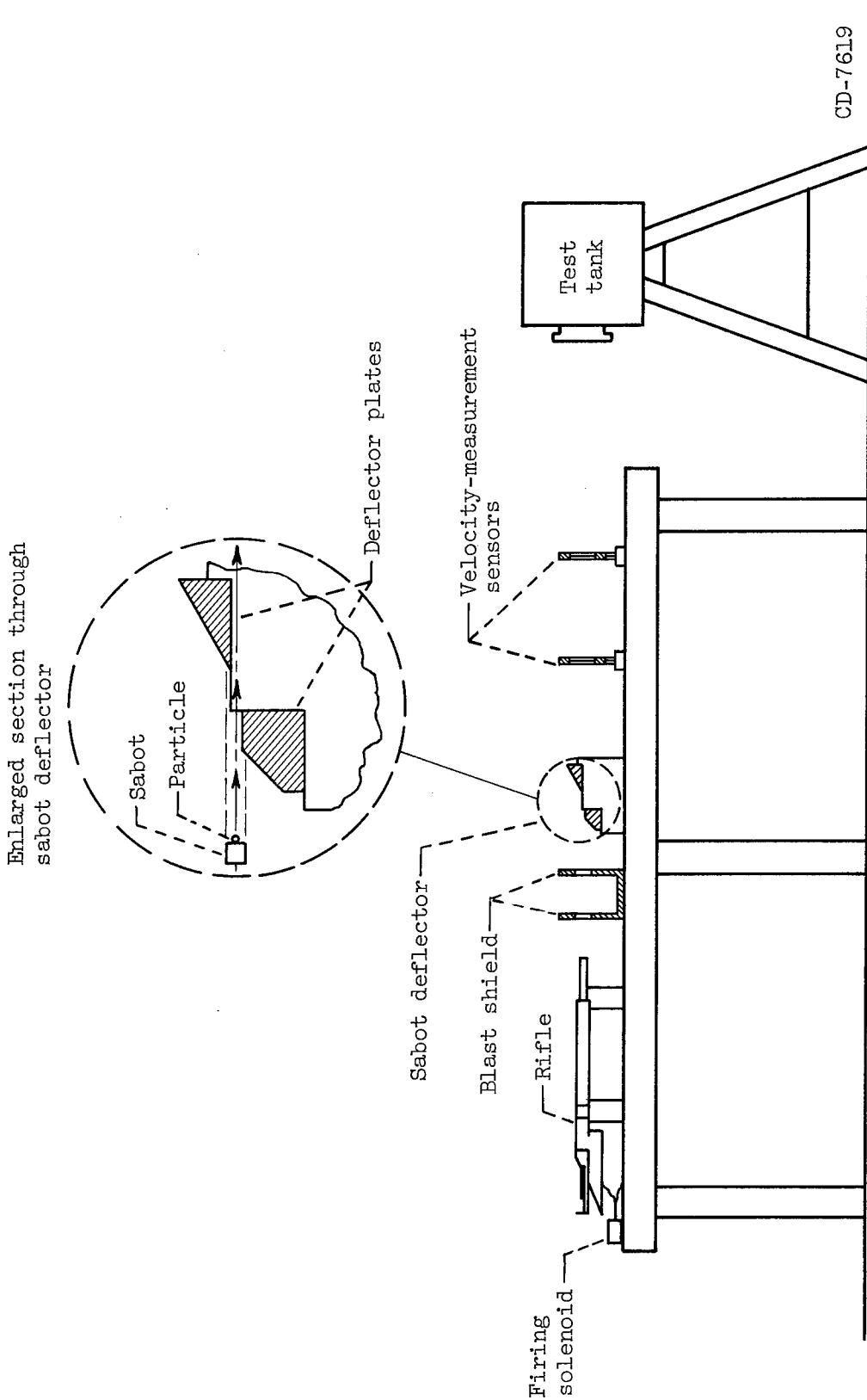
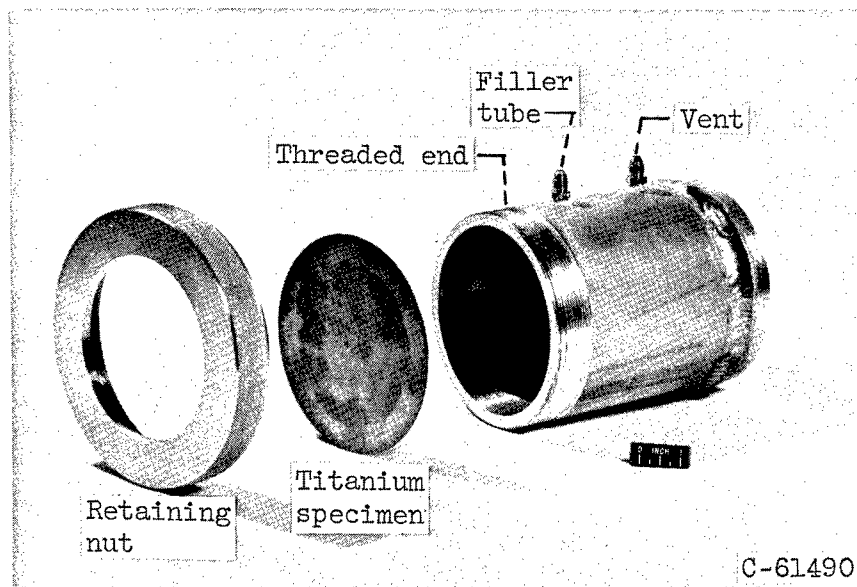
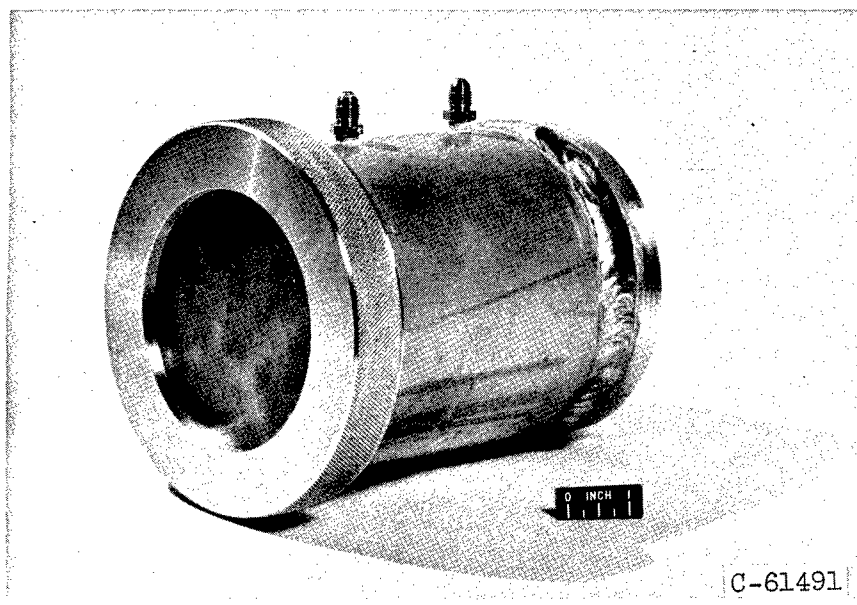

Figure 1. - Schematic drawing of apparatus for high velocity impact tests on simulated propellant tanks.



(a) Exploded view.



(b) Assembled view.

Figure 2. - Specially designed tank with titanium specimen.

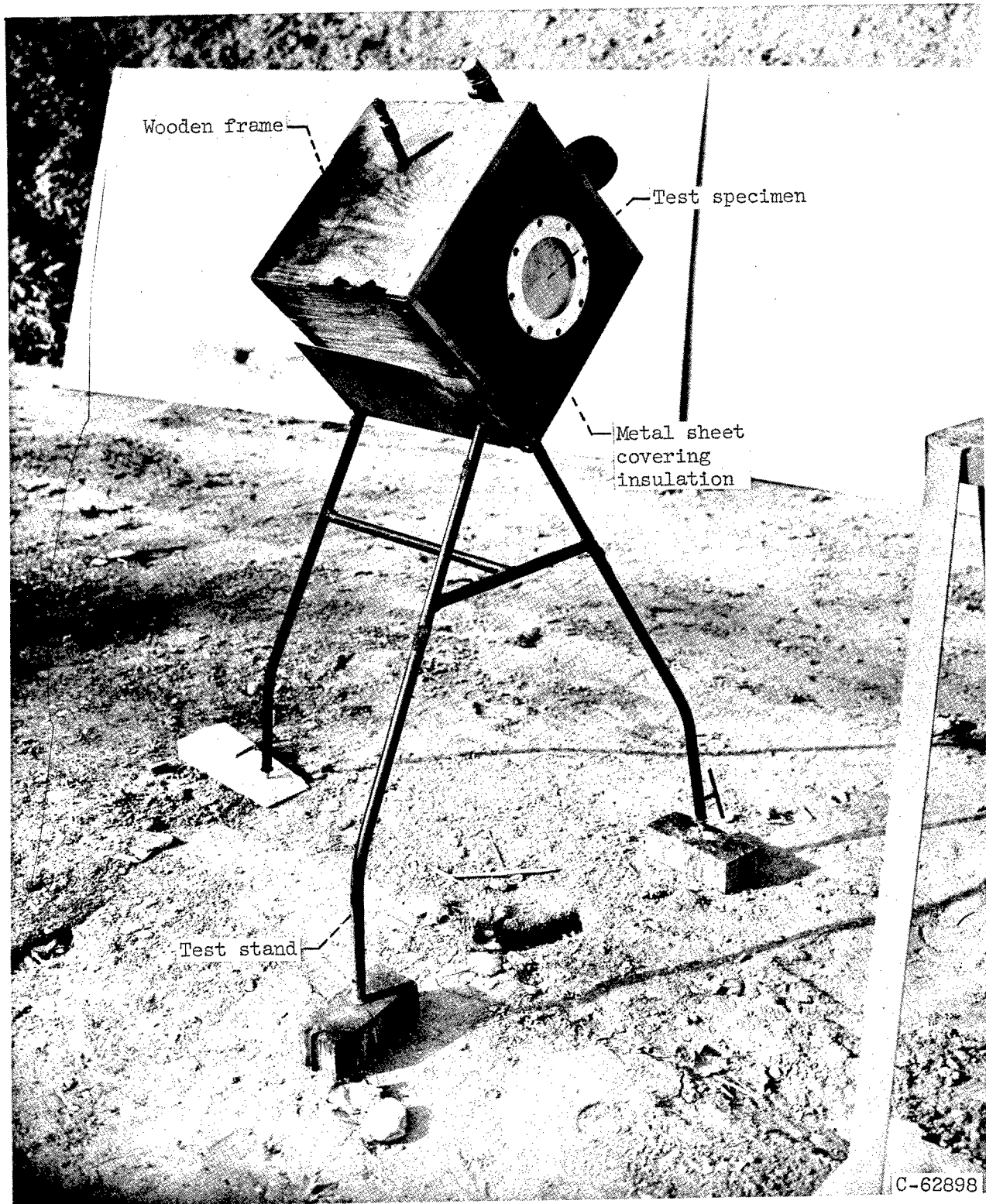
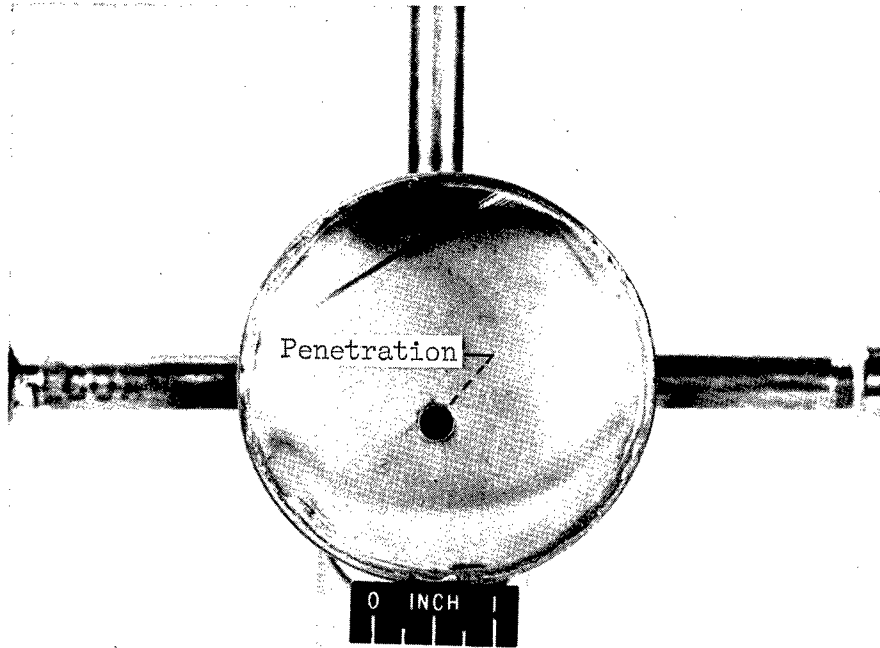
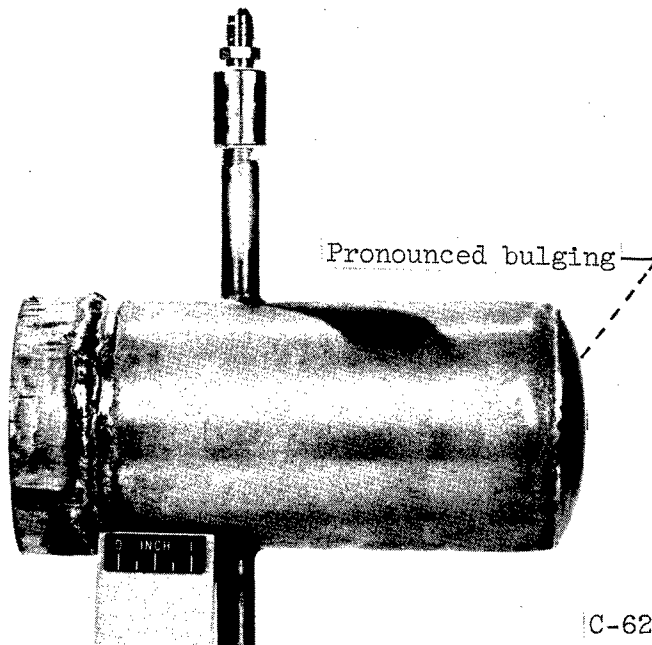

Figure 3. - Stand and typical insulated tank used for liquid-oxygen tests.



C-62879

(a) End view.



C-62878

(b) Side view.

Figure 4. - Results of impact of steel projectile into stainless-steel tank filled with hydrazine. Test 1.

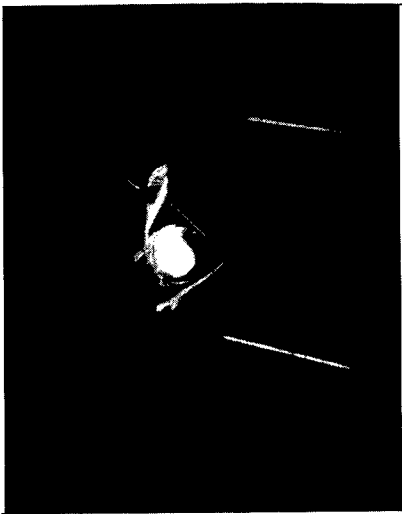

0.4



Impact



Before impact

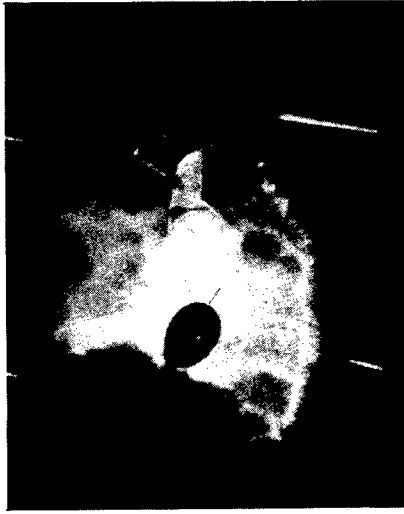

6.8

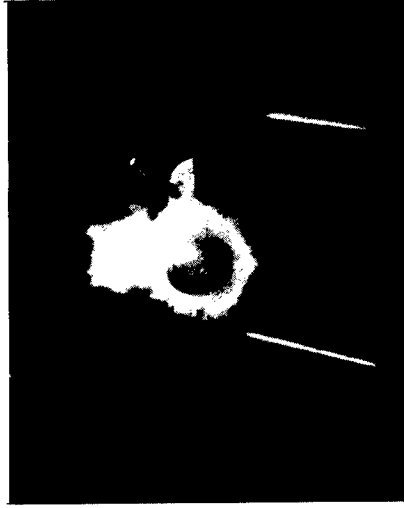

1.5



0.8

C-64257

Figure 5. - Selected frames from motion picture taken of impact by steel projectile into aluminum tank filled with hydrazine. Test 2. (Time after impact given in milliseconds.)



Figure 6. - Results of impact by steel projectile into aluminum tank filled with hydrazine. Test 2.

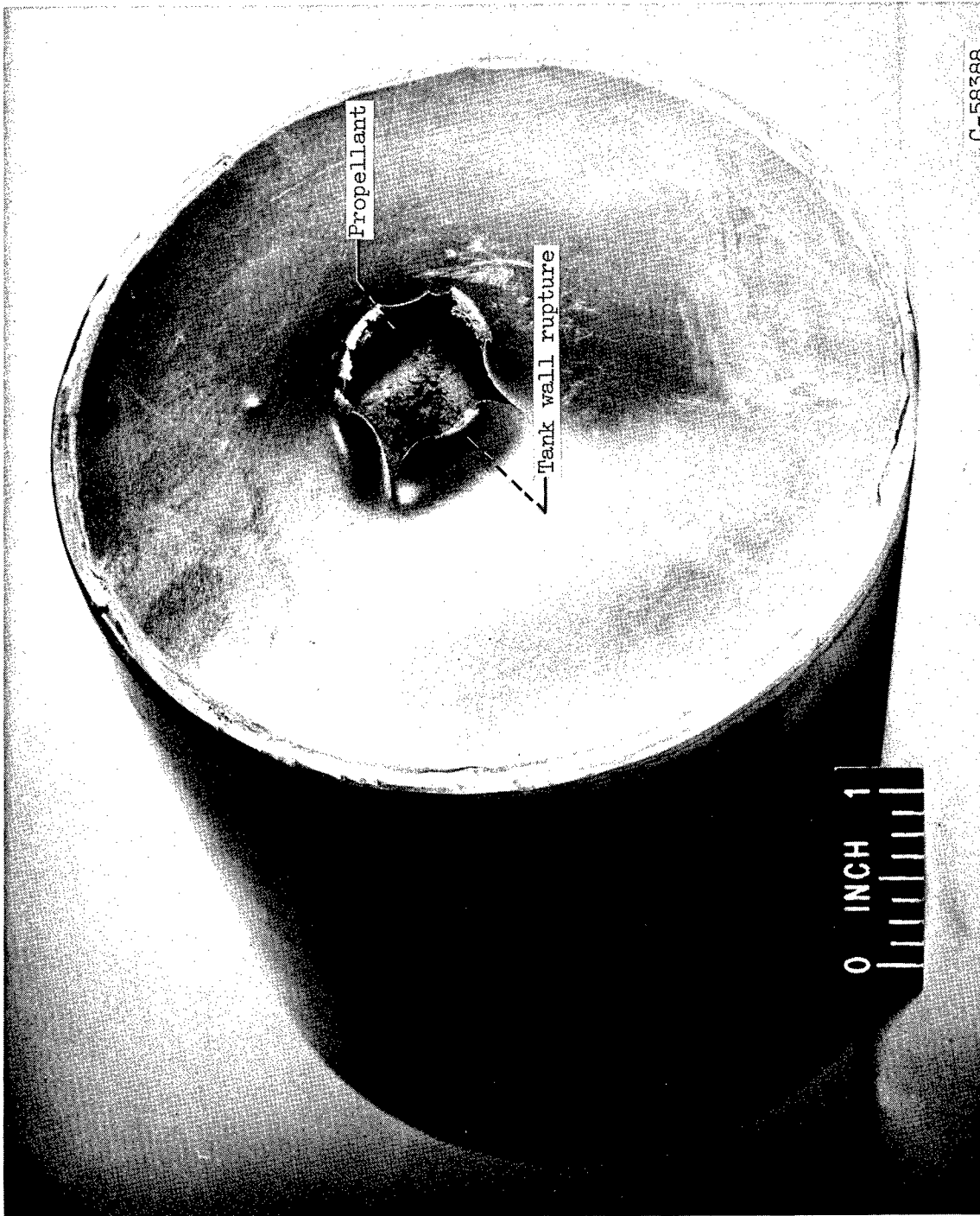
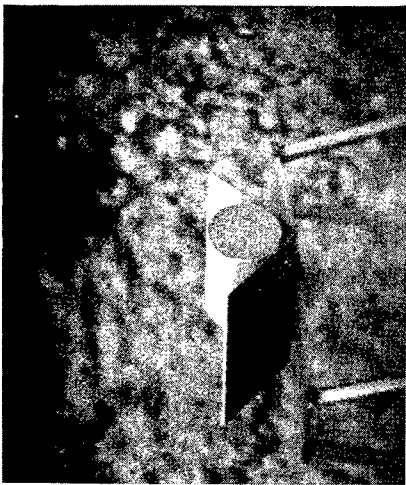

Figure 7. - Results of impact by steel projectile into aluminum tank filled with Arcite 373.
Test 6.



Before impact



Impact

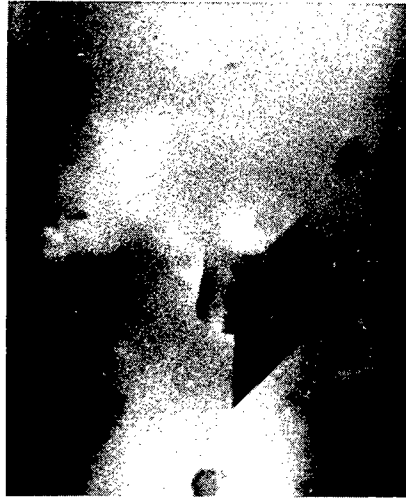

7



18

42

50

C-64256

(a) Camera at left of test stand.

Figure 8. - Selected frames from motion picture taken of impact by steel projectile into aluminum tank filled with Hercules CLW. Test 7. (Time after impact given in milliseconds.)



110

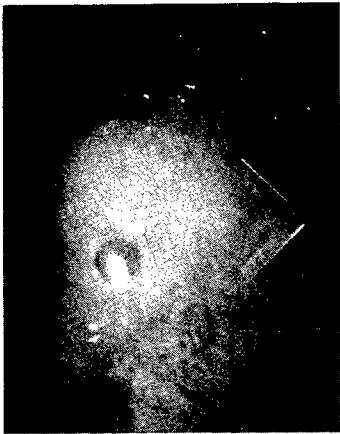

277



357



416



447

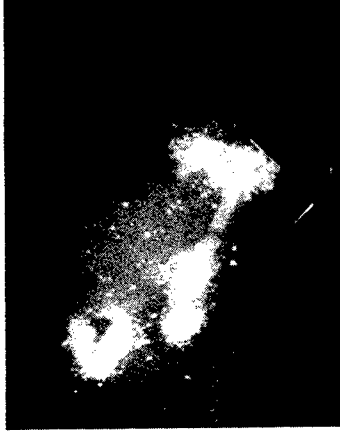

496



606

(b) Camera at right of test stand.

Figure 8. - Concluded. Selected frames from motion picture taken of impact by steel projectile into aluminum tank filled with Hercules CLW. Test 7. (Time after impact given in milliseconds.)



Pieces of impacted tank end

C-58383

Figure 9. - Results of impact by steel projectile into aluminum tank filled with Hercules CLW.
Test 7.



Before Impact

61



Impact

84

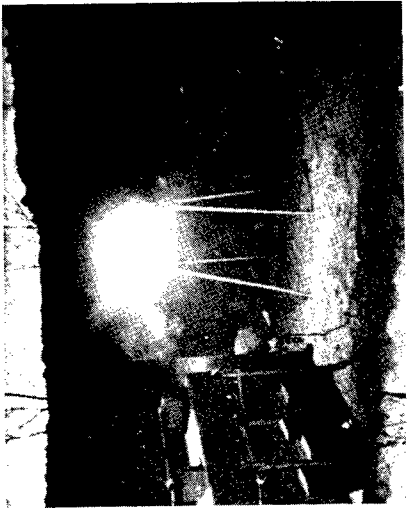

5



1480

C-64254

Figure 10. - Selected frames from motion picture taken of typical impact and penetration of titanium wall of tank filled with liquid oxygen. Test 14. (Time after impact given in milliseconds.)

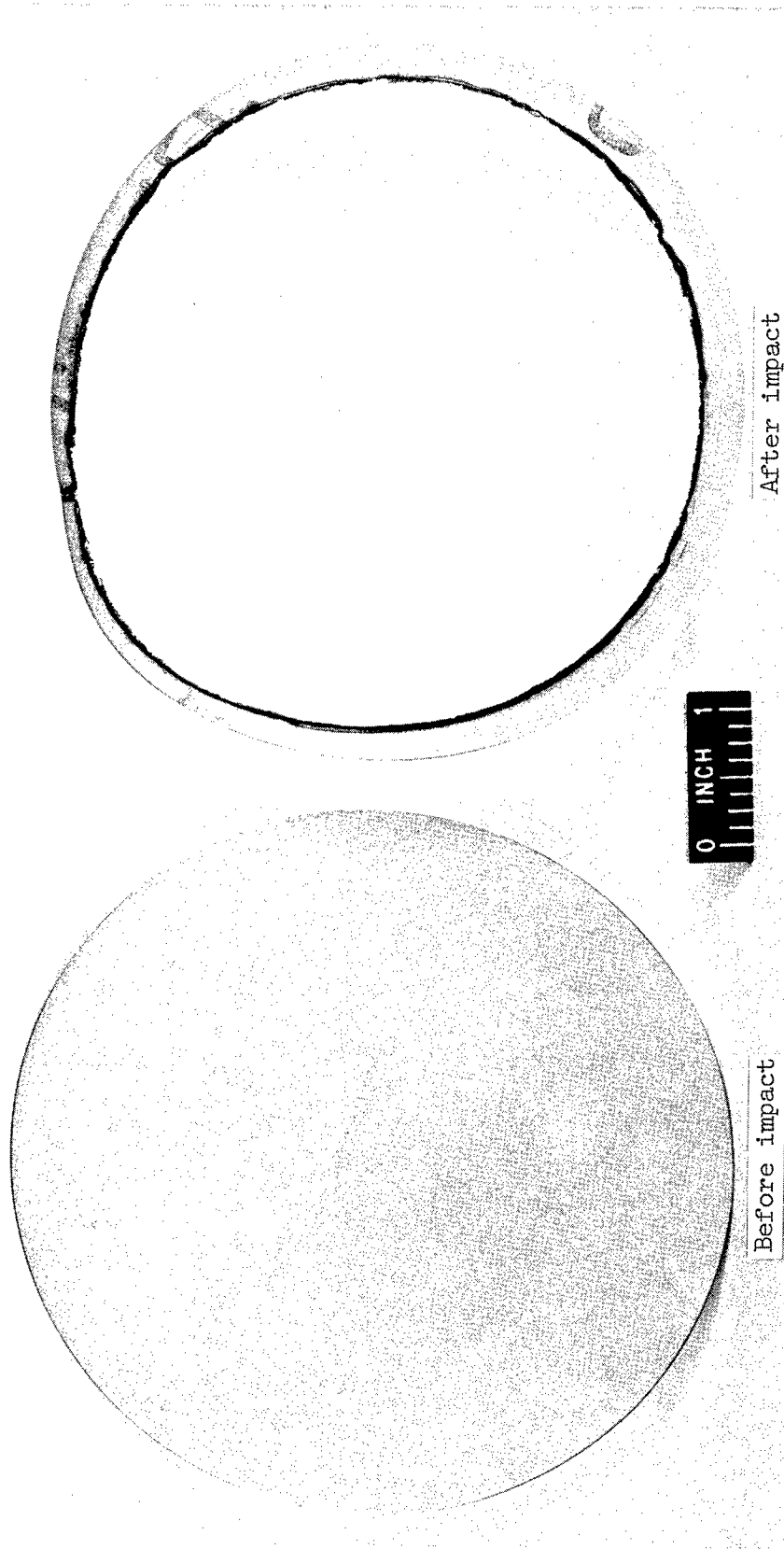

After impact

Before impact



C-58607

Figure 11. - Typical result of impact and penetration of titanium wall of tank filled with liquid oxygen.



Figure 12. - Condition of tank after impact and penetration of titanium wall of tank filled with liquid oxygen. Test 8.

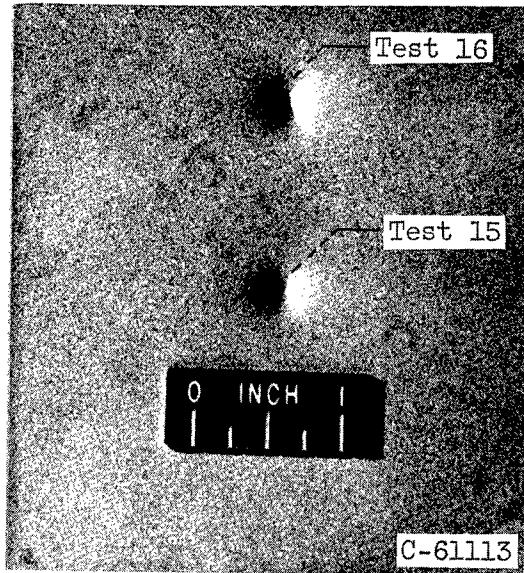

(a) Impacted surface.

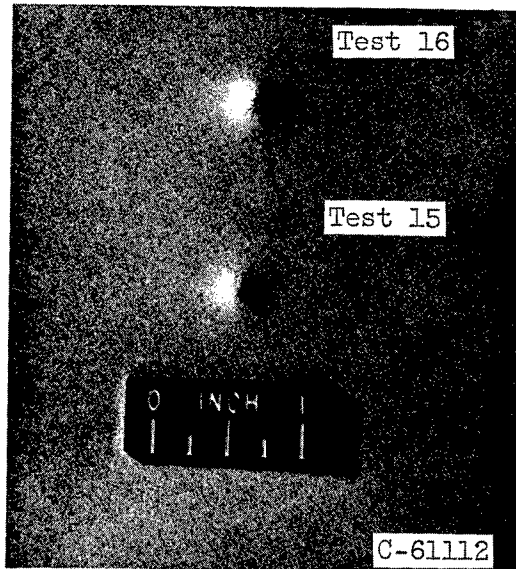

(b) Surface in contact with liquid oxygen.

Figure 13. - Results of impacts without complete penetration of titanium wall of tank filled with liquid oxygen.

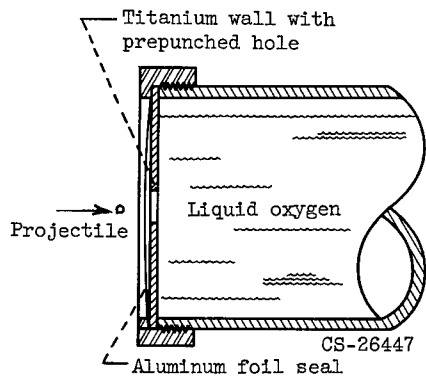

(a) Schematic of test tank.

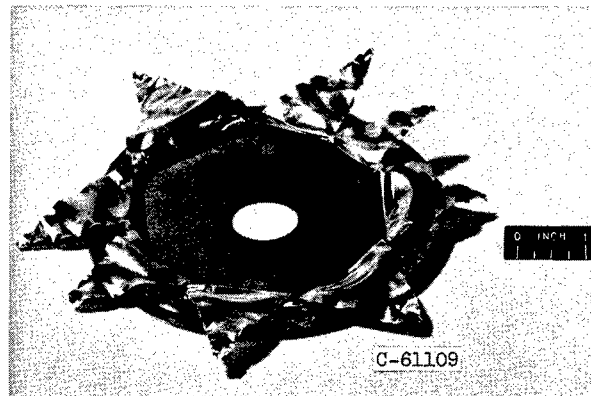

(b) Front side of titanium disk after impact.

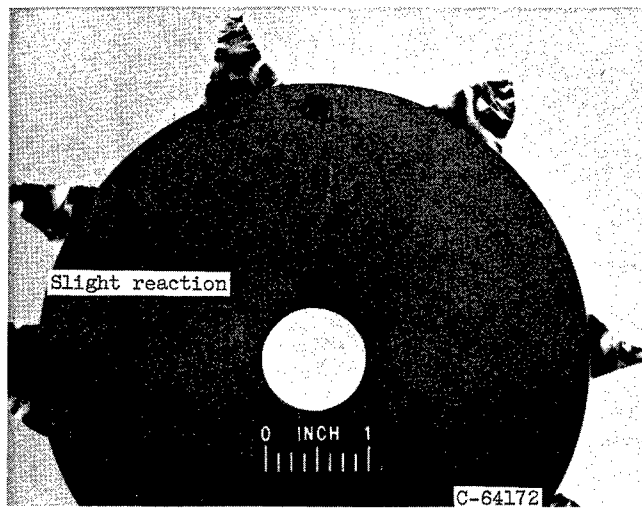

(c) Reverse side of titanium disk after impact.

Figure 14. - Impact test on prepunched titanium specimen covered with aluminum foil. Test 27.



Before impact



After impact

C-64171

Steel sphere



Before impact



After impact

C-64170

Aluminum sphere

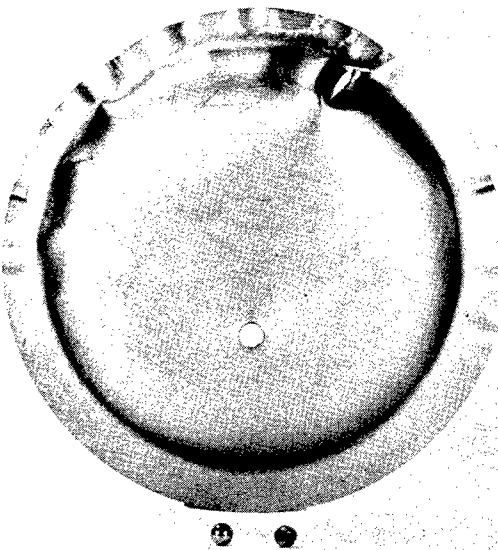

Wall impacted by steel sphere

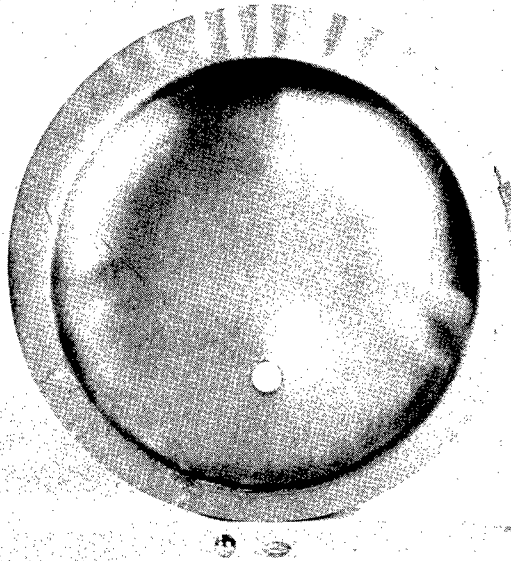

Wall impacted by aluminum sphere



C-62880

Figure 15. - Results of impacts and penetrations of titanium walls of tank filled with nitrogen tetroxide. (Impacted side of specimens shown.)



Figure 16. - Damage resulting from impact by steel projectile into titanium tank filled with Hercules CLW. Test 36.



Figure 17. - Results of impacts and penetrations of glass-cloth-reinforced epoxy walls of tank filled with liquid oxygen.

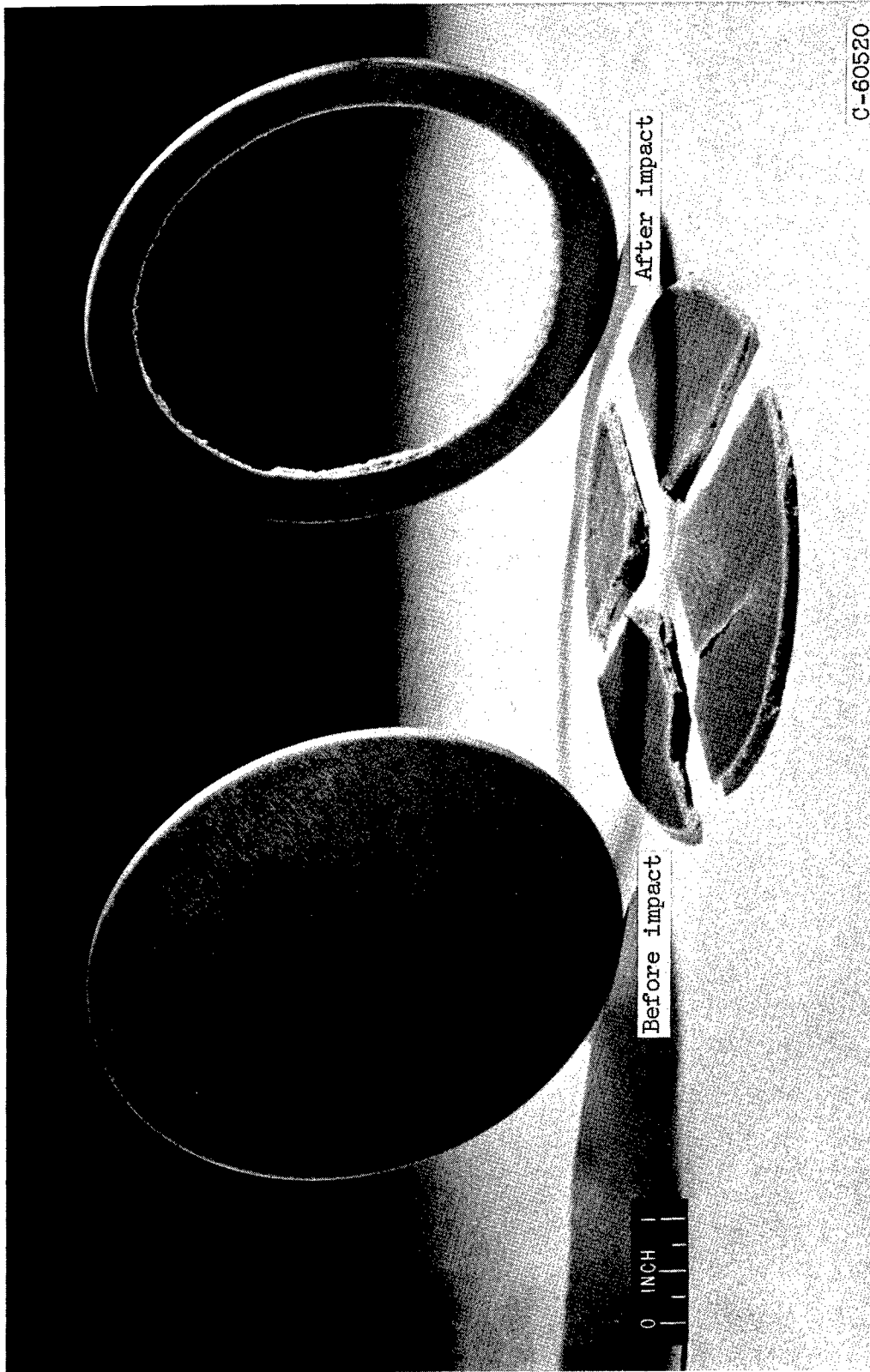

Figure 18. - Results of impact and penetration of nylon-cloth-reinforced phenolic wall of tank filled with liquid oxygen. Test 39.



Figure 19. - Results of impact and penetration of Dacron-fiber-reinforced polyurethane wall of tank filled with liquid oxygen. Test 40.

A motion-picture film supplement C-222 is available on loan. Requests will be filled in the order received. You will be notified of the approximate date scheduled.

The film (16 mm, 7 min, color, sound) shows the violent reaction that results from the high-velocity-projectile penetration of a titanium wall of a tank filled with liquid oxygen.

The film may be borrowed on application to the

Chief, Technical Information Division
National Aeronautics and Space Administration
Lewis Research Center
21000 Brookpark Road
Cleveland 35, Ohio

CUT

Date _____

Please send, on loan, copy of film supplement C-222 to
TN D-1882

Name of organization

Street number

City and State

Attention: Mr. _____
Title _____

Place
stamp
here

Chief, Technical Information Division
National Aeronautics Space Administration
Lewis Research Center
21000 Brookpark Road
Cleveland 35, Ohio