

305124

DP - 418

UNCLASSIFIED

Metallurgy and Ceramics

AEC Research and Development Report

ULTRASONIC ENERGY APPLIED TO
ALUMINUM EXTRUSION CLADDING OF TUBES

by

J.B. Jones C.F. DePrisco
N. Maropis J. G. Thomas

AEROPROJECTS INCORPORATED
West Chester, Pennsylvania

November 1959

DISTRIBUTION STATEMENT A
Approved for Public Release
Distribution Unlimited

[REDACTED]

[REDACTED]

the disclosure of its contents in any manner to
an unauthorized person is prohibited.

PROPERTY OF

20011221 107

Issued by

E. I. du Pont de Nemours & Co.
Savannah River Laboratory
Aiken, South Carolina

UNCLASSIFIED

contains Confidential
information relating to civilian
applications of atomic energy.

[REDACTED]

This report was prepared as an account of Government sponsored work. Neither the United States, nor the Commission, nor any person acting on behalf of the Commission:

- A. Makes any warranty or representation, expressed or implied, with respect to the accuracy, completeness, or usefulness of the information contained in this report, or that the use of any information, apparatus, method, or process disclosed in this report may not infringe privately owned rights; or
- B. Assumes any liabilities with respect to the use of, or for damages resulting from the use of any information, apparatus, method, or process disclosed in this report.

As used in the above, "person acting on behalf of the Commission" includes any employee or contractor of the Commission, or employee of such contractor, to the extent that such employee or contractor of the Commission, or employee of such contractor prepares, disseminates, or provides access to, any information pursuant to his employment or contract with the Commission, or his employment with such contractor.

Printed in USA. Price \$0.95

Available from the U. S. Atomic Energy Commission
Technical Information Service Extension
P. O. Box 1001, Oak Ridge, Tennessee

Please direct to the same address inquiries covering the procurement of other classified AEC reports.

 **UNCLASSIFIED**

DP - 418

METALLURGY AND CERAMICS
(M-3679, 23rd Ed.)



ULTRASONIC ENERGY APPLIED TO
ALUMINUM EXTRUSION CLADDING OF TUBES

by

J. Byron Jones
Carmine F. DePrisco
Nicholas Maropis
John G. Thomas

Aeroprojects Incorporated
West Chester, Pennsylvania

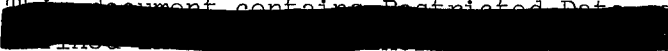
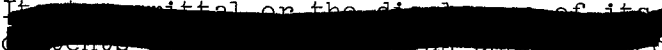
November 1959

This document contains Restricted Data

It is to be controlled on the same basis as its



Issued by
E. I. du Pont de Nemours & Co.
Explosives Department - Atomic Energy Division
Technical Division - Savannah River Laboratory

Printed for
The United States Atomic Energy Commission
Contract AT(07-2)-1

Reproduced From
Best Available Copy

UNCLASSIFIED

 UNCLASSIFIED

ABSTRACT

Ultrasonic energy appropriately applied to the die or container of a laboratory-type direct extrusion press effected a marked increase in the free extrusion rate of lead and aluminum billets at a constant extrusion force, and a significant decrease in force at a constant extrusion rate. The same results were obtained in extrusion cladding steel tubes with aluminum. Rate increases were generally 100 per cent or greater, and decreases in force were usually within the range of 10 to 20 per cent. Furthermore, the shape and slope of the extrusion curves were altered. The effect appeared to be attributable to a reduction of both die friction and container wall friction under ultrasonic influence.

UNCLASSIFIED

UNCLASSIFIED

CONTENTS

	<u>Page</u>
List of Figures	4
List of Tables	4
List of Charts	5
Introduction	6
Summary and Conclusions	6
Discussion	7
Extrusion of Lead Billets	7
Experimental Equipment	7
Experimental Procedures	8
Results and Discussion	8
Extrusion of Aluminum Billets	10
Experimental Equipment	10
Experimental Procedures	11
Results and Discussion	11
Aluminum Extrusion Cladding of Tubes	13
Ultrasonic Equipment	13
Laboratory Extrusion Tests with Lead Billets	15
Procedures for Extrusion Cladding Tests	16
Results and Discussion	17
Bibliography	19

UNCLASSIFIED

LIST OF FIGURES

<u>Figure</u>		<u>Page</u>
1	Experimental Extrusion Array Incorporating Ultrasonically Activated Die, Used in Early Lead Extrusion Studies	20
2	Ultrasonic Quadridrive Coupler-Die Assembly Used in Early Aluminum Extrusion Runs	21
3	Full-Scale Vertical Extrusion Cladding Press with Ultrasonic Equipment Installed	22
4	Ultrasonic Transducer-Coupling-Container Assembly for Full-Scale Extrusion Cladding Press	23
5	Inside Cladding Extrusion Tool Assembly	24
6	5-Kilowatt Motor-Alternator Set Used for Driving Ultrasonic Transducer-Coupling in Aluminum Extrusion Cladding Tests	25
7	Ultrasonic Extrusion Cladding Array Assembled for Preliminary Checkout with Free Lead Extrusions	26
8	Head End of Ultrasonic Extrusion Array of Figure 7 with Asbestos Jacket Removed	27

LIST OF TABLES

<u>Table</u>		
I	Effects of Ultrasonic Energy Applied During Direct Extrusion of Lead	28
II	Effects of Ultrasonic Energy Applied During Direct Extrusion of Aluminum Billets	29
III	Summary of Aluminum Extrusion Cladding Tests	30

LIST OF CHARTS

<u>Chart</u>		<u>Page</u>
1	Effect of Ultrasonically Activated Ram on Extrusion of Lead	31
2	Effect of Ultrasonically Activated Die on Extrusion of Lead	32
3	Effect of Ultrasonically Activated Container on Extrusion of Lead	33
4	Extrusion of Lead Billets Without Ultrasonic Activation	34
5	Pressure Required for Extrusion of Lead Under Ultrasonic and Non-Ultrasonic Conditions	35
6	Ultrasonic Effect on Force Required for Extrusion of Solid Aluminum Billet with Shear Die	36
7	Ultrasonic Effect on Force Required for Extrusion of Laminated Aluminum Billet with Shear Die	37
8	Ultrasonic Effect on Force Required for Extrusion of Solid Aluminum Billet with Conical Die	38
9	Ultrasonic Effect on Force Required for Extrusion of Laminated Aluminum Billet with Conical Die	39
10	Pulsed Ultrasonic Extrusion of Solid Aluminum Billet with Shear Die	40
11	Pulsed Ultrasonic Extrusion of Solid Aluminum Billet with Conical Die	41
12	Laboratory Tests in Extrusion of Lead Using Ultrasonic Equipment Assembled for Full-Scale Extrusion Cladding	42
13	Aluminum Extrusion Cladding Test No. 2	43
14	Aluminum Extrusion Cladding Tests No. 5 and No. 7	44
15	Aluminum Extrusion Cladding Test No. 6	45
16	Aluminum Extrusion Cladding Test No. 8	46
17	Aluminum Extrusion Cladding Test No. 9	47
18	Aluminum Extrusion Cladding Test No. 10	48

[REDACTED]

ULTRASONIC ENERGY APPLIED TO ALUMINUM EXTRUSION CLADDING OF TUBES

INTRODUCTION

The manufacture of certain types of tubular fuel elements for nuclear reactors requires the cladding of uranium or other core material with 1100 aluminum. Extrusion cladding is one of several promising methods currently under development, but difficulties are encountered because of the high extrusion forces required and the low extrusion rates achieved.

It appeared that ultrasonic energy appropriately applied during the extrusion process could facilitate metal flow and alleviate some of the cladding difficulties. Apparently no prior experimentation had been carried out along these lines, and nothing was known of the problems involved or the results achievable. However, brief experimentation in other areas had indicated that elastic vibratory energy could effectively reduce frictional forces, as demonstrated, for example, in the assembly of a tube on a stepped mandrel in which the clearance between the mandrel and the inside tube wall was progressively decreased to zero; ultrasonic application had also facilitated the assembly of concentric tubes in which the clearance between them was small. These results suggested that frictional forces between the extrusion metal and the container walls, as well as between the extruding metal and the die surface, might be significantly reduced by appropriately applied ultrasonic energy, permitting extrusion to be accomplished at higher rates or with lower applied forces.

A program was therefore initiated to investigate specific ultrasonic effects in the extrusion process and to determine the significance of ultrasonic parameters such as mode of vibration and power level. Initial feasibility studies were made with lead, which is a metal relatively easy to extrude; operating temperatures with this metal are not high, and significant data on variables involved in conventional lead extrusion were available.⁽¹⁾ Later work involved free extrusion of aluminum and ultimately extrusion cladding of tubes.

SUMMARY AND CONCLUSIONS

Short
Experiments in the direct extrusion of lead[^] billets were carried out at a temperature of approximately 295°C and an extrusion ratio of 25:1, using a laboratory extrusion press incorporating provisions for ultrasonic activation of the die, the ram, and the container. Extrusion force was held constant while variations in rate were recorded. In tests involving alternate ultrasonic and non-ultrasonic extrusion on the same billet, the ultrasonic extrusion rate ranged from 13 to 88 per cent greater than the corresponding non-ultrasonic rate. Calculations from available data indicated that with constant ram speed the extrusion force would be decreased by 4 to 15 per cent under ultrasonic influence.]

Comparison of the ultrasonic data with results obtained from billets extruded entirely without ultrasonic application showed rate increases up to 300 per cent and calculated force decreases up to 28 per cent. In addition, the shape and slope of the curves of extrusion force vs. speed were significantly altered with ultrasonic application.

Subsequent experiments with direct extrusion of aluminum billets at a temperature of approximately 525°C and an extrusion ratio of 11:1 confirmed the beneficial effect on extrusion force when the die was ultrasonically activated. With a shear die, the initial extrusion force at a constant ram speed of 0.18 inch per minute was decreased by 15 to 18 per cent; with a conical die, the decrease in force was in the range of 5 to 7 per cent. The favorable effect on extrusion force was immediately apparent whenever the ultrasonic power was turned on or off.

Appropriate ultrasonic equipment was then assembled for introducing vibratory energy into the internal extrusion die region of a full-scale vertical tube-cladding press. During several experimental runs on the modified full-scale press, aluminum cladding was extruded under both ultrasonic and non-ultrasonic conditions, at a temperature of 593°C, onto the inside of steel tubing 4-1/2 feet long. At a constant extrusion force of 40 tons, ultrasonic application increased the cladding rate generally by about 100 per cent and in one case by as much as 250 per cent. In one test, a cladding rate normally achieved with an extrusion force of 51.5 tons was produced at 44 tons under ultrasonic influence. As with the extrusion of lead billets, vibratory application during extrusion cladding appeared to have a favorable residual effect on non-ultrasonic cladding rates on the same tube, and the shape and slope of the extrusion curves were markedly changed.

This preliminary investigation has therefore established significant increases in rate and/or decreases in force with ultrasonic application not only to the free extrusion of lead and aluminum but also to the aluminum extrusion cladding of tubes. The magnitude of these effects is believed to be sufficient to warrant installation of ultrasonic equipment on production extrusion presses.

DISCUSSION

EXTRUSION OF LEAD BILLETS

EXPERIMENTAL EQUIPMENT

A small laboratory direct-extrusion array was assembled for the initial experiments with lead billets, with provisions for separate ultrasonic activation of the die, the ram, and the container. The use of a straight-through, flat-faced die with a bore of 0.25 inch and a cylindrical container with an inside diameter of 1.25 inches provided a reduction ratio of 25:1 or a percentage reduction of 96 per cent,

which is within the workable range for the extrusion of lead. The assembly was mounted on the crosshead of a 30,000-pound hydraulic testing machine (Figure 1), which provided the necessary force application and indication. Heat was supplied by cartridge heaters embedded in the container walls, supplemented by strap-on heaters. Temperatures were monitored through the use of thermocouples located in the container walls and were controlled within the desired range by means of a suitable temperature controller.

The die was ultrasonically activated axially with respect to the orifice by means of twin transducers attached to a hollow split coupler, as illustrated in Figure 1; axial vibration was introduced into the ram through a transducer-coupling screw-connected to the bottom of the ram; and flexural vibration of the container was achieved with a transducer-coupling attached at right angles to the cylinder. All transducers were laminated nickel stacks operating at a nominal frequency of 20 kilocycles per second.

EXPERIMENTAL PROCEDURES

Lead billets 1.25 inches in diameter and 6 inches long were extruded under ultrasonic and non-ultrasonic conditions at a temperature of approximately 295°C. During each test, the force applied to the ram, as indicated on the dial of the test array, was held constant. Meanwhile, the efflux rate was continuously recorded using a slide-wire potentiometer attached to the emerging lead extrusion and providing voltage signals through a d-c amplifier to a strip-chart recorder.

After preliminary tests to check the equipment and establish procedures, several billets were extruded under alternating ultrasonic and non-ultrasonic conditions and at alternating force levels of 7500 and 10,500 pounds. In each case, the billet was placed in the container and heated to 295°C; vibratory energy was applied, the force was adjusted to 7500 pounds, and the extrusion rate was recorded over a 10-second interval. The ultrasonic power was then cut off, and non-ultrasonic data at the same force level were recorded for 10 seconds. This was followed by a similar period of ultrasonic and non-ultrasonic extrusion at 10,500-pound force. The complete cycle was repeated until essentially all of the billet had been extruded. The experimental program included several tests of this type with ultrasonic activation of the die, one test with activation of the ram, and one with activation of the cylinder. Additional billets were extruded entirely without ultrasonic application to establish baseline control data.

RESULTS AND DISCUSSION

Typical results obtained with the intermittent application of ultrasonic energy are presented in Charts 1, 2, and 3, and data for the non-ultrasonic control extrusions are plotted in Chart 4; in all instances ram speed (obtained from the efflux rate by applying the extrusion ratio) is shown as a function of ram position.

Several trends are apparent from these charts. In all instances, ram speed with ultrasonic application was significantly greater than that obtained during corresponding non-ultrasonic periods on the same billet. The magnitude of the increase, calculated at the 2-inch ram-travel position, ranged from 13 to 88 per cent; data for individual tests are given in Columns 4 and 5 of Table I. The results indicated that activation of the die was substantially more effective than that of the ram or the container, and the single test (No. 13) at increased power level showed the greatest ultrasonic effect. Calculations from cross-plots of the data obtained in these tests showed force reductions under ultrasonic influence ranging from 4 to 15 per cent; again die activation at maximum power was most effective.

The curves of Charts 1 and 2, obtained with vibration of the ram and the die, show a more or less progressive increase in extrusion rate as the billet became shorter. With the ultrasonically activated container (Chart 3), the ram speed increased only slightly as extrusion progressed. The curves representing non-ultrasonic extrusion have an unusual shape. Whereas extrusion rate is normally uniform at constant pressure and temperature,^(2,3) the curves in Chart 4 show a dip in the center. Both temperature and pressure were carefully controlled during these runs, and no explanation for the noted variation in ram speed is available.

Further comparison of these data indicates that the ram speeds obtained for both ultrasonic and non-ultrasonic portions of Tests 10-16 were substantially higher than the speeds obtained with the control billets. It therefore appears that vibratory application during extrusion of a single billet had a residual beneficial effect on the non-ultrasonically extruded sections of the same billet.

A method provided by Pearson⁽¹⁾ permits valid comparison of the ultrasonic and control tests in terms of extrusion pressure (in tons per square inch) as a function of ram speed. Ultrasonic data from the above tests at the 2-inch ram-travel position were appropriately converted and plotted in Chart 5, along with similar data from the non-ultrasonic control tests.* Since the relationship is linear, data from two extrusion forces permit extrapolation as shown by the dotted lines. Ram speeds at a selected extrusion pressure of 3.5 tons per square inch and extrusion pressures at a selected ram speed of 0.2 inch per minute were used to calculate the apparent ultrasonic effects shown in the last two columns of Table I, which indicate ram-speed increases ranging from 100 to 300 per cent or force reductions of 16 to 28 per cent under ultrasonic influence.

* Plotted pressures for Tests 16, 19, and 20 differ from those for the earlier tests because the cylinder was reamed to a slightly larger diameter to eliminate warpage; the reduction in cross-sectional area during extrusion was thereby increased from 96 to 96.7 per cent.

It was therefore concluded that high-frequency vibratory energy appropriately applied to the direct extrusion of lead results in substantial increases in extrusion rate and/or reductions in extrusion force. It remained to be determined whether the same trends were characteristic in the direct extrusion of aluminum.

EXTRUSION OF ALUMINUM BILLETS

EXPERIMENTAL EQUIPMENT

The ultrasonic extrusion array used with lead was subsequently modified to permit direct extrusion of aluminum billets. Since the light metals and alloys are more difficult to extrude than lead, provisions were incorporated for a lower reduction ratio, higher extrusion forces, higher temperature, and increased ultrasonic power.

For convenient comparison with earlier work in extrusion of aluminum,⁽¹⁾ an extrusion ratio of 11:1 or percentage reduction of 90.8 was selected. This was provided by a container diameter of 1.350 inches and a die orifice of 0.407 inch. The container was machined from a steel tube and was lined with shock-resistant tool steel*, the inside diameter of which was precision-machined and ground to a smooth finish. The ram was made of the same type of tool steel, precision-machined to 1.330 inches to provide a clearance of 0.010 inch between the ram and the container wall. Two types of dies were fabricated. One was a flat-faced shear die of the type used with the earlier lead extrusions, and the other was a conical-faced die with a 90° included lead-in angle. Structural components were designed to withstand pressures up to 50,000 psi. The array was mounted, as before, on the crosshead of the hydraulic testing machine.

The equipment provided for ultrasonic activation of the die, since this technique appeared most promising for application to extrusion cladding of long tubes. To provide increased power delivery, the quadridrive transducer array of Figure 2 was assembled. The four 20-kc nickel-stack transducers, driven by a single power source, were capable of accepting up to 1500 watts from a 2-kilowatt ultrasonic generator. A special force-insensitive mount was used between the transducer-coupling assembly and the die to insure that the applied extrusion forces would not affect operation of the ultrasonic array or energy transmission into the die.

The container was heated by Calrod-type heaters that permitted operation in the temperature range of 500-550°C. Appropriate temperature controlling and recording equipment was incorporated in the experimental array.

* "Omega" Tool Steel (Bethlehem Steel Co.).

Whereas the earlier lead extrusions had been carried out at constant force while variations in rate were recorded, the aluminum was extruded at fixed ram speed and variations in force were recorded. A precise-rate monitoring system devised to permit control of extrusion rate was found to be accurate within ± 3 per cent. Accurate force indication required faster response than was obtainable with the dial gage on the experimental array, and this was obtained by means of a bridge-type pressure transducer* installed in the hydraulic line of the testing machine. Electric signals from the transducer were fed to a strip-chart recorder and converted to pounds of applied force from an accurately prepared calibration chart.

EXPERIMENTAL PROCEDURES

After preliminary extrusion runs with both lead and aluminum to check operation of the equipment and establish operating procedures, eleven aluminum billets were extruded under varying conditions. Seven runs were made using solid 1100-F aluminum rods 1-1/4 inches in diameter and 4-1/2 to 5 inches long. In the other four tests, provisions were made for studying the flow pattern of the extruded metal, using a billet consisting of circular disks of 1/4-inch-thick aluminum with fine copper shot of 0.011-inch diameter interposed between the disks; prior to extrusion, each compound billet was compressed under a 15,000-pound load to effect adhesion between the layers. Billets of each type were extruded entirely with and without continuous ultrasonic application; corresponding runs were made with the shear die and with the conical die. In addition, one test with each die was made with the ultrasonic energy pulsed, on for 0.25 inch of ram travel and off for a similar period. The conditions for each test are summarized in Table II.

The operating procedure involved heating the container to approximately 525°C, then inserting the billet and allowing a 15-minute soak period at this temperature to insure uniform heat distribution. No extrusion lubricant was used for any of the tests. The billets were extruded at a constant extrusion rate of 2 inches per minute, or a ram speed of approximately 0.18 inch per minute, and extrusion was discontinued with 1 inch of the original billet remaining in the container. Ultrasonic energy, when used, was applied just before extrusion was initiated. Temperatures at several thermocouple locations in the container wall were recorded continuously throughout each test. After removal from the container, the residual sections of the laminated billets were sectioned axially for examination of the flow pattern.

RESULTS AND DISCUSSION

The typical curve of extrusion pressure vs. ram travel for aluminum by the direct extrusion method, as provided by Pearson,⁽¹⁾ shows an abrupt

* Type 4-311 Pressure Pickup (Consolidated Engineering Corp., Pasadena, California).

rise in force as the billet is compressed to fill out the container, reaching a maximum as extrusion is initiated; the force then decreases gradually to a minimum near the end of the billet, and rises rapidly when only a thin disk remains to be forced into the die orifice. The curves for the extrusion runs on this program (Charts 6-11) show the same general configuration except that the final rise in force is not evident because the billets were not completely extruded.

Minor difficulties encountered in maintaining accurate temperature control during the tests are reflected in the temperature range data of Table II. Variations from 507 to 548°C were recorded during the tests, and temperatures in the vicinity of the die at the peak force varied from 518 to 538°. Since temperature has a marked effect on required extrusion force, the original force data from the tests were corrected to a temperature of 525°C according to a formula derived by Shishokin⁽⁴⁾ and confirmed for several aluminum alloys by Pearson⁽¹⁾: $P = Ae^{-\lambda T}$, where P is extrusion pressure, A is a constant depending on experimental conditions, λ is a plasticity coefficient for the extrusion (verified at 0.0082 for 99.5 per cent aluminum), and T is the extrusion temperature. The curves of Charts 6, 7, 8, and 9 reflect these temperature corrections so that valid comparisons of ultrasonic and non-ultrasonic data are possible. Originally recorded peak forces and corrected peak force values for each test are listed in Table II.

The data of Chart 6, representing extrusion of a solid aluminum billet through the shear die, show that vibratory application reduced the peak extrusion force by about 15 per cent. Tests with the same die but using laminated billets (Chart 7) show a 19 per cent reduction under ultrasonic influence. Results with the conical-faced die, although not so impressive, likewise showed peak force reduction with ultrasonic activation (Charts 8 and 9), the reductions being in the range of 5 to 7 per cent.

This effect of vibration in reducing extrusion pressure is further graphically illustrated in the results of Tests 15 and 19 (Charts 10 and 11), in which the ultrasonic energy was pulsed. Without exception, whenever the power was turned on, the extrusion pressure abruptly decreased by a significant amount and increased substantially when the power was turned off again. The instantaneous decreases were in the order of 10 to 25 per cent with the shear die and 5 to 12 per cent with the conical die. Since these differential values were not essentially different from those obtained from Charts 6-9, it appeared that a residual ultrasonic effect on non-ultrasonically extruded portions of the same billet, such as that observed with lead, did not occur in the free extrusion of aluminum although, as noted later, this residual effect was observed in extrusion cladding with aluminum.

The exact mechanism of the ultrasonic effect in facilitating extrusion was not established in these early studies, although it is believed to be associated with the reduction of friction between the extruding

billet and the container wall as well as that between the extruding metal and the die bearing. The brief flow-pattern studies made in connection with Tests 14, 15, 20, and 21 showed some evidence of less circuitous metal flow in the vicinity of the ram face in the ultrasonically extruded billets, but the results were generally inconclusive. Further studies could profitably be made to determine the effective ultrasonic mechanism.

Of primary importance, these tests with aluminum confirmed the favorable ultrasonic effects previously achieved with lead and established force reductions of the order of 15 to 20 per cent in the direct extrusion of aluminum, thus providing a sound basis for investigating ultrasonic application to aluminum extrusion cladding.

ALUMINUM EXTRUSION CLADDING OF TUBES

ULTRASONIC EQUIPMENT

Having established a favorable effect of ultrasonic energy applied during free extrusion of lead and aluminum, ultrasonic equipment was devised for installation on a full-scale vertical extrusion press to determine the magnitude of such effects on the aluminum cladding of tubes.

The extrusion press provided for simultaneous inside and outside cladding of tubes having an inside diameter of 2.75 inches and up to about 16 feet long. Inside cladding was accomplished with a hydraulically activated vertical ram which extruded aluminum from above through a three-webbed container tip and thence through an 0.050-inch die annulus onto the inside tube surface, while horizontal rams extruded aluminum onto the adjacent outside tube surface. Downward travel of the tube was induced by the force of the metal extruding inside the tube.

The basic approach selected for ultrasonic equipment design and installation on such a system, represented schematically in Figure 3, consisted of introducing vibratory energy from below into the internal container tip. The equipment consisted of an enclosed transducer-coupling cluster assembly joined to a slender, mandrel-like steel coupler rod, the upper end of which was attached to the container stud. The entire array could be elevated to the desired height and supported by means of a hydraulic jack or similar device. The transducer-coupling assembly is represented schematically in Figure 4, and details of the coupler-container junction are shown in Figure 5.

Experimental extrusion cladding of tubes up to 5 feet long required an ultrasonic coupler 6 to 8 feet long and approximately 2-1/2 inches in diameter. A rod of this size with a uniform diameter would have a high bending stiffness and introduce the possibility of fracture at the junction between the container stud and the webs of the container

tip. The coupler was therefore designed with one section necked down to a diameter of 1-1/16 inches; this should significantly reduce the bending stiffness and provide sufficient elastic deflection to prevent fracture of the webs. The necked-down section was screw-connected at one end to the container stud, in contact with the die ring, and at the other end to a rod approximately 4-1/2 feet long. Brief laboratory measurements revealed no difficulty with this design.

To provide for increased ultrasonic power delivery over that available for the earlier free aluminum extrusions, the design of the multiple transducer-coupling assembly previously used (Figure 2) was modified to incorporate six standard 20-kc transducer stacks instead of the original four. Each stack was capable of absorbing about 1000 electrical watts without undue cooling difficulties. The necessary driving power for the array was provided by the 5-kilowatt, 20-kc motor-alternator set illustrated in Figure 6, replacing the electronic driving apparatus previously used. This equipment insured the generation of high acoustical power levels.

Consideration was given to the effect of the small cross-sectional area represented by the necked-down section on the transmission of energy to the vicinity of the die. The smallest cross section provided approximately 0.85 square inch (5.5 square centimeters) of area to be traversed by the elastic longitudinal waves. Theoretical investigations carried out in connection with other work revealed the possibility of transmitting a maximum of approximately 12 kilowatts per square centimeter through steel cross sections at stress levels below an assumed endurance limit of 15,000 pounds per square inch; with a high standing-wave ratio, indicating low efficiency, the energy transmission may fall to a value of about 200 watts per square centimeter. Since the maximum theoretical capacity of the necked-down section was approximately 66 kilowatts, it appeared that little difficulty should be encountered in transmitting power of less than 5 kilowatts into the vicinity of the container tip and die ring.

To be effective, this energy should be transmitted through the container tip itself because coupling into the container walls was not feasible. It had previously been calculated that the die-container system should be resonant at approximately 20 kc. The motor-alternator set operated at a frequency of 20 \pm 1.5 kc, and the entire transducer-coupling assembly was designed for a nominal frequency of 20 kc. To verify preliminary calculations after assembly of the array, laboratory investigations were made into the acoustical wave pattern existent within the die, the central post bridge in the container tip, and the container itself. These studies revealed resonance conditions in the desired frequency range of 19.7 to 20.4 kc. The measurements were made with no heated metal in the container; however, the presence of plastic metal at elevated temperature was expected only to load the system and not appreciably modify the resonance characteristics of the steel components.

After the essential equipment had been assembled and checked out as noted above, and prior to installation on the extrusion press, it was installed in a horizontal position in a laboratory array, as depicted in Figures 7 and 8, to determine its effectiveness in actual extrusion operation. The framework of this laboratory array consisted of a Delta 100-ton arbor press turned on its side to provide clearance for the long coupler. Figure 7 shows the transducer-coupling cluster (without its housing) and the coupler leading into an asbestos-jacketed section which contained the necked-down coupler, die ring, container tip, and container. This section incorporated heating capacity for achieving operating temperatures up to 250°C, since it was planned to carry out the laboratory tests only with lead extrusions. Figure 8 illustrates this section with the asbestos jacket removed; the ram and the container with their supports are also shown. The array permitted monitoring of extrusion force on the ram both by means of the pressure gage in the hydraulic system and by suitably installed strain gages.

The equipment was found to perform satisfactorily in the laboratory tests. The ultrasonic components were subsequently assembled on the full-scale vertical press in the manner shown in Figure 3, minor modifications being made as required. Floor tests indicated the same frequency and resonance conditions as had been obtained in the laboratory.

LABORATORY EXTRUSION TESTS WITH LEAD BILLETS

The equipment array of Figures 7 and 8 was used for lead extrusion runs primarily to check out the ultrasonic components and to establish that the results obtained in the early lead extrusions could be approximated with this new specialized array. Although the die ring and container tip were those designed for extrusion cladding, only free extrusions were made in these preliminary runs. Calculations based on the container diameter and the dimensions of the die annulus indicated an extrusion ratio of 5.32:1. In each case a 1.75-inch-diameter lead billet was placed in the container and heated to 250°C, after which extrusion was initiated with or without ultrasonic application as desired.

Initial tests were made with short billet lengths (approximately 12 inches) to investigate variables of extrusion force, extrusion rate, and ultrasonic power; the results showed the anticipated ultrasonic effects. For example, at a billet length of 11-1/16 inches, a force of 4.12 tons was required to initiate extrusion at 800 watts ultrasonic power; with approximately the same billet length (10-1/2 inches), 6.18 tons was required under non-ultrasonic conditions. Ultrasonic application thus decreased extrusion force by approximately 33 per cent, which is substantially greater than the improvement previously obtained with either lead or aluminum (cf. Tables I and II). At billet lengths in the range of 9-1/2 to 7-1/2 inches and at a fixed extrusion force of 8.25 tons, the extrusion rate was increased by a factor of 3 under

ultrasonic influence. As in the earlier tests, the change in ram travel speed was immediately apparent whenever the ultrasonic energy was turned on or off.

Two parallel runs were made with 26-inch billets, one entirely without ultrasonic application and one with ultrasonic energy constantly applied at a power level to the transducer of 1400-1600 watts. No effort at continuous extrusion was made, and neither force nor rate was held constant. The objective was rather to determine a series of starting forces at various ram positions. The results are graphically shown in Chart 12, in which extrusion forces are plotted as a function of billet length. As anticipated, the extrusion force decreased as the billet became shorter because of reduced wall friction. It is noteworthy that the ultrasonic curve lies significantly below that of the control and that the shapes of the curves are somewhat different. The control curve has a constant slope, whereas the ultrasonic curve appeared to change slope at a billet length of about 19-1/2 inches; no explanation for this change was apparent. The decreases in required force under ultrasonic influence ranged from about 20 to 80 per cent.

These preliminary tests with lead confirmed previous beneficial results and established satisfactory operation of the ultrasonic array in preparation for the extrusion cladding tests.

PROCEDURES FOR EXTRUSION CLADDING TESTS

After the ultrasonic array had been installed on the full-scale extrusion cladding press as shown in Figure 3, several experimental runs were made in cladding steel tubes with aluminum, using no lubricant to facilitate the extrusion. The major variables in these tests are summarized in Table III. The tests not included in the table (Nos. 1 and 3) were not completed because of mechanical difficulties with the press, and fracture of the container tip in the third test caused postponement of additional runs for several weeks. After a new tip had been fabricated and installed, the balance of the program continued without interruption.

Since the ultrasonic energy was introduced only into the internal extrusion components, only inside cladding was applied in seven of the eight tests. Inside and outside cladding were applied simultaneously in Test No. 9.

A substantial amount of data involving constant extrusion force had previously been obtained with the experimental full-scale extrusion press used in these tests. Therefore, after the ultrasonic equipment was installed, most of the runs were made at constant force while variations in rate were recorded. The force was 40 tons except in Test No. 8, in which 44 tons was applied. In No. 9, which involved both inside and outside cladding, effort was made to maintain constant extrusion rate, although minor variations in rate occurred; in this instance both rate and force variations were recorded.

To insure constant conditions, the first few tubes, as well as the last, were extrusion-clad alternately for 3 minutes under non-ultrasonic conditions followed by 3 minutes of ultrasonic application, allowing 15 seconds for stabilization at the end of each period. Test No. 7 was accomplished entirely without ultrasonic application to establish base-line data and to check non-ultrasonic data previously obtained with the extrusion press. No. 8 was produced entirely with ultrasonic activation to evaluate the effect of the higher force (44 tons). In several instances the vibratory power level was varied in an effort to evaluate the effect of this parameter.

From the dimensions of the die used in these experimental runs and the billet diameter, the extrusion ratio was calculated to be 8.8:1. Temperature in the vicinity of the container tip was automatically controlled at 593°C. Throughout each run, readings were taken periodically, usually at 1-minute intervals, of tube travel, ram travel, billet length, ultrasonic power, and extrusion force.

RESULTS AND DISCUSSION

The effects of ultrasonic application during extrusion cladding with aluminum are apparent in the Curves of Charts 13-18, most of which show the rate of tube travel (i.e., the rate of extrusion cladding) as a function of billet length.

In all instances the extrusion cladding rate was significantly increased by ultrasonic application. Least improvement was shown in Test No. 2 (Chart 13) in which the ultrasonic cladding rate was only 20 to 30 per cent over the non-ultrasonic rate on the same tube. However, the extrusion press difficulties, apparently not related to the ultrasonic equipment, experienced during this early testing interval probably affected test results. Test No. 5 (Chart 14) showed rate increases of 30 to 60 per cent; No. 6 (Chart 15), 100 to 175 per cent; and No. 10 (Chart 18), 75 to 250 per cent increases in rate. The maximum ultrasonic effect appeared to be obtained with the longest billets (i.e., when the initial billet length approached 25 inches), suggesting that an important contributing ultrasonic mechanism was the reduction of wall friction between the billet and the container.

In connection with the earliest lead extrusion work, it was noted that ultrasonic application appeared to have a residual effect on non-ultrasonically extruded portions of the same billet, although this effect was not observed in the early free extrusion of aluminum billets. However, the residual ultrasonic effect appeared to accompany the aluminum extrusion cladding, as illustrated on Chart 14. Non-ultrasonic Test No. 7 showed a tube travel rate substantially below that of the non-ultrasonically extruded portions in Test No. 5. The data obtained in No. 7 were believed to be reliable since they duplicated results previously obtained in non-ultrasonic cladding with the same extrusion press (i.e., before the ultrasonic array was installed). Further

comparison of the two non-ultrasonic curves on Chart 14 reveals a difference in their shape and slope, and this difference too had been noted with the early lead extrusions.

Studies specifically oriented to the investigation of ultrasonic power showed no apparent effect of power level on tube travel rate, at least at powers above about 1400-1500 watts. Chart 18, for example, represents a range of power levels from 450 to 2300 watts. In the first half of the curve, all power levels used, from 1200 to 2300, appeared equally efficacious. Chart 14 shows that even the relatively low power level of 925-950 watts produced a pronounced rate increase.

The single cladding run at an applied extrusion force of 44 tons (Chart 16) revealed similar beneficial effects of ultrasonic application. Data previously obtained for non-ultrasonic extrusions on the same press indicated that a force of approximately 51.5 tons would normally be required (at the same billet length) to achieve the cladding rate of 2.5 to 3.5 inches per minute that was achieved ultrasonically at 44 tons. The reduction in force was approximately 15 per cent.

Significant results were also obtained with simultaneous inside and outside tube cladding, as illustrated in Chart 17. Although effort was made to maintain a constant tube travel rate, the rate increased by 25 to 40 per cent when the ultrasonic power was applied and dropped a corresponding amount when it was turned off. At the same time, extrusion force decreased by approximately 10 per cent under ultrasonic influence. Thus in this instance favorable effects on rate and force were achieved simultaneously.

These results confirm the trends observed with free extrusion of lead and aluminum billets and indicate that appropriately applied ultrasonic energy can significantly aid aluminum extrusion cladding of tubes by increasing extrusion rates and/or decreasing extrusion forces.

BIBLIOGRAPHY

1. Pearson, C. E., The Extrusion of Metals. John Wiley & Sons, Inc. New York, 1953, pp. 115-137.
2. Tammann, G., "On the Rate of Extrusion of Crystalline Substances." Ann. Physik., Vol. 7 (1902), p. 198; Vol. 10 (1903), p. 647.
3. Portevin, A., "Experiments on the Compression and Extrusion of Metals and Alloys at High Temperatures." Rev. de Metallurgie, Vol. 26 (1929), pp. 435-443.
4. Shishokin, W. P., "The Extrusion Properties of Metals and Alloys at Different Temperatures." Zhurnal Prikladnoi Khimii, Vol. 2 (1929), p. 663.

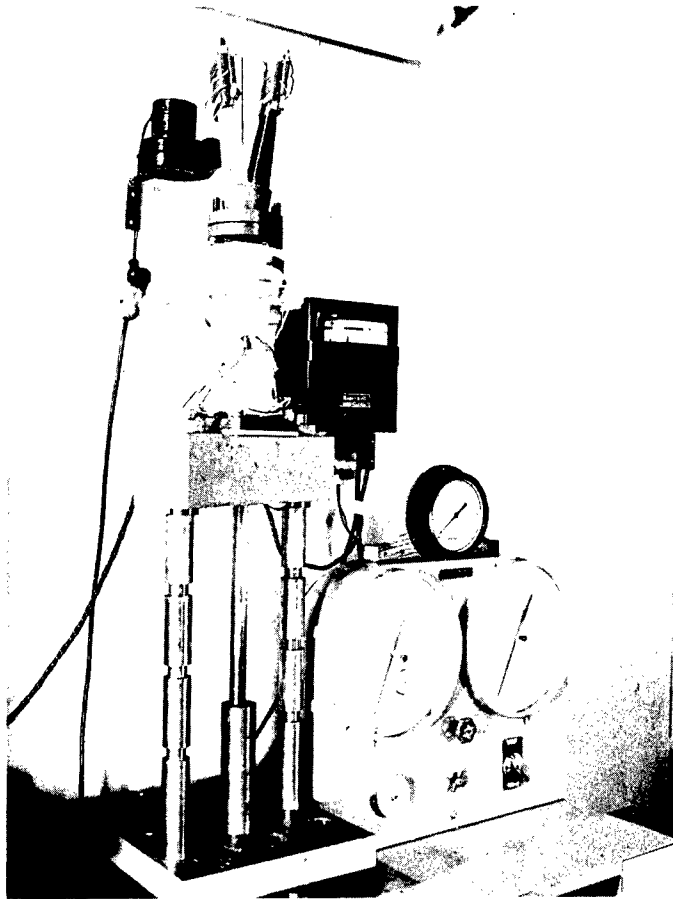
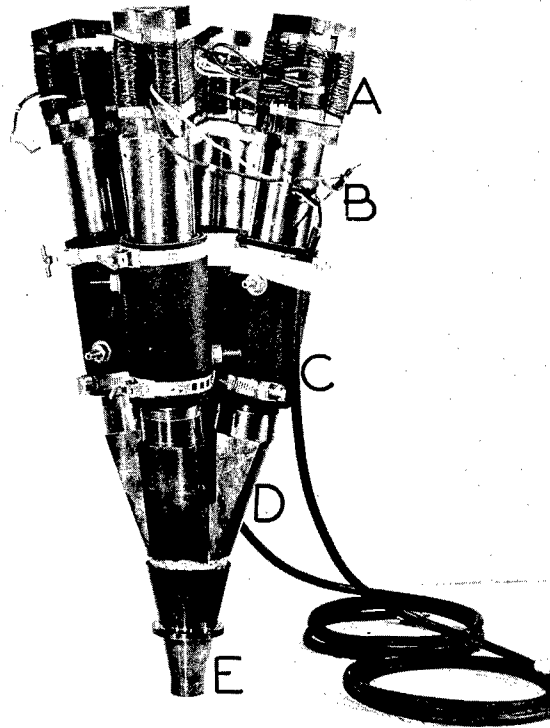

Figure 1

EXPERIMENTAL EXTRUSION ARRAY
INCORPORATING ULTRASONICALLY ACTIVATED DIE,
USED IN EARLY LEAD EXTRUSION STUDIES



- A. Transducer
- B. Coupler
- C. Water cooling jacket
- D. Coupler adapter
- E. Die and mount

Figure 2

ULTRASONIC QUADRIDRIVE COUPLER-DIE ASSEMBLY
USED IN EARLY ALUMINUM EXTRUSION RUNS

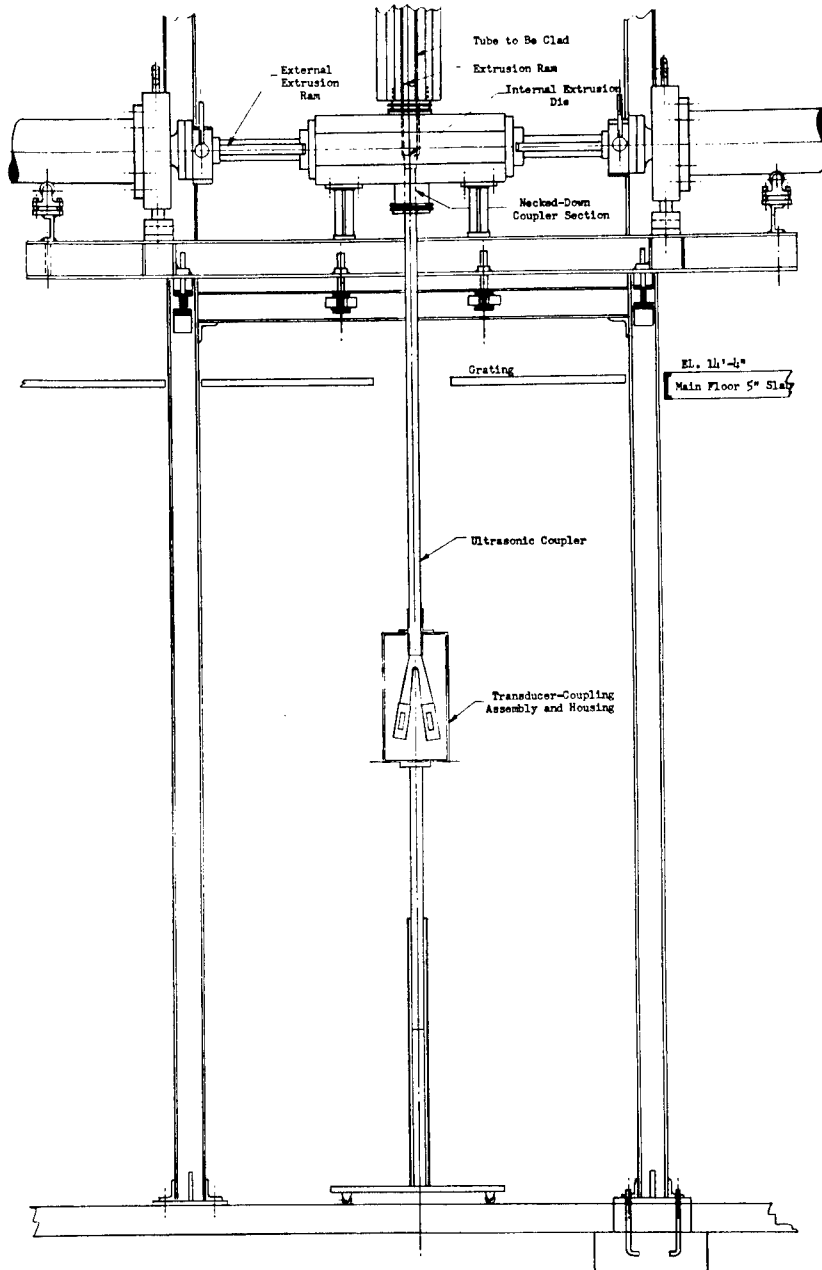

Figure 3

FULL-SCALE VERTICAL EXTRUSION CLADDING PRESS
WITH ULTRASONIC EQUIPMENT INSTALLED

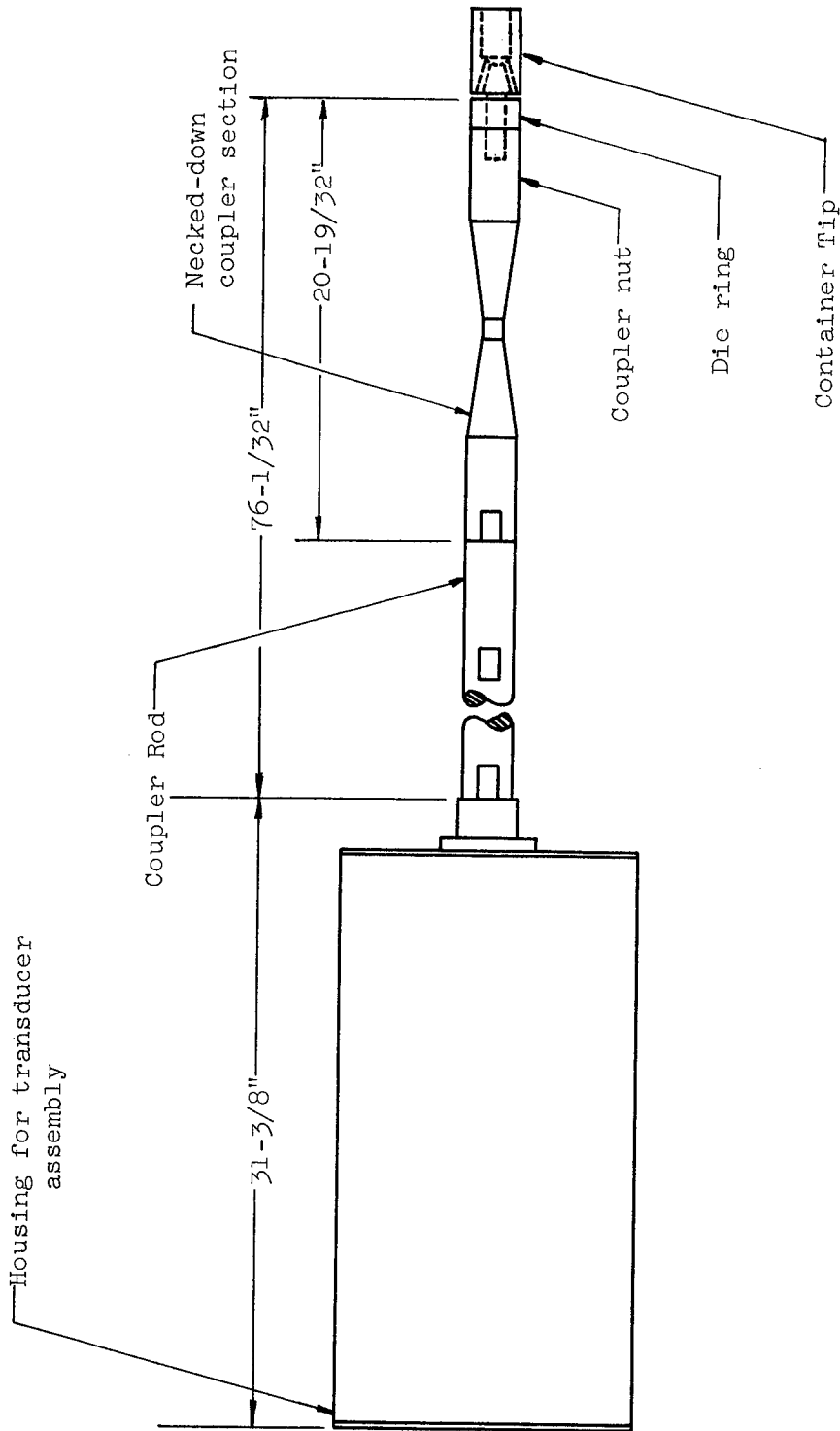

Figure 4
 ULTRASONIC TRANSDUCER-COUPLING-CONTAINER ASSEMBLY
 FOR FULL-SCALE EXTRUSION CLADDING PRESS

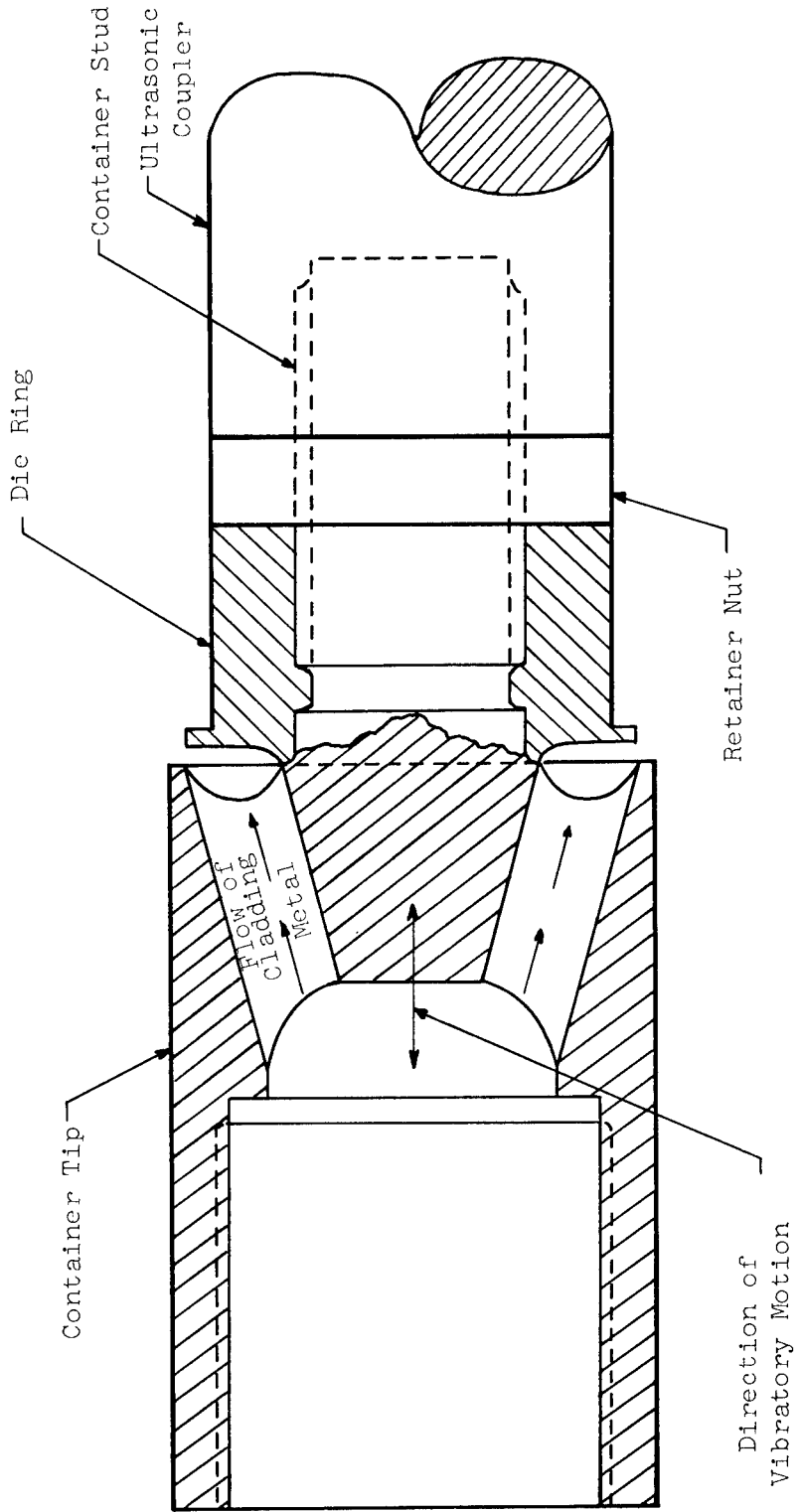

Figure 5
 INSIDE CLADDING EXTRUSION TOOL ASSEMBLY
 (Approximate actual scale)

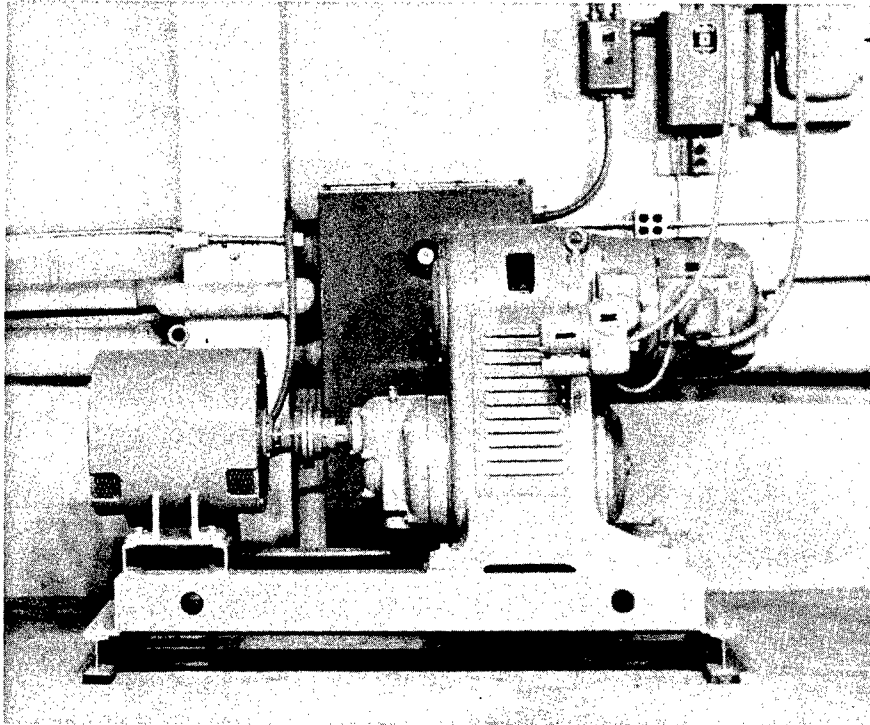
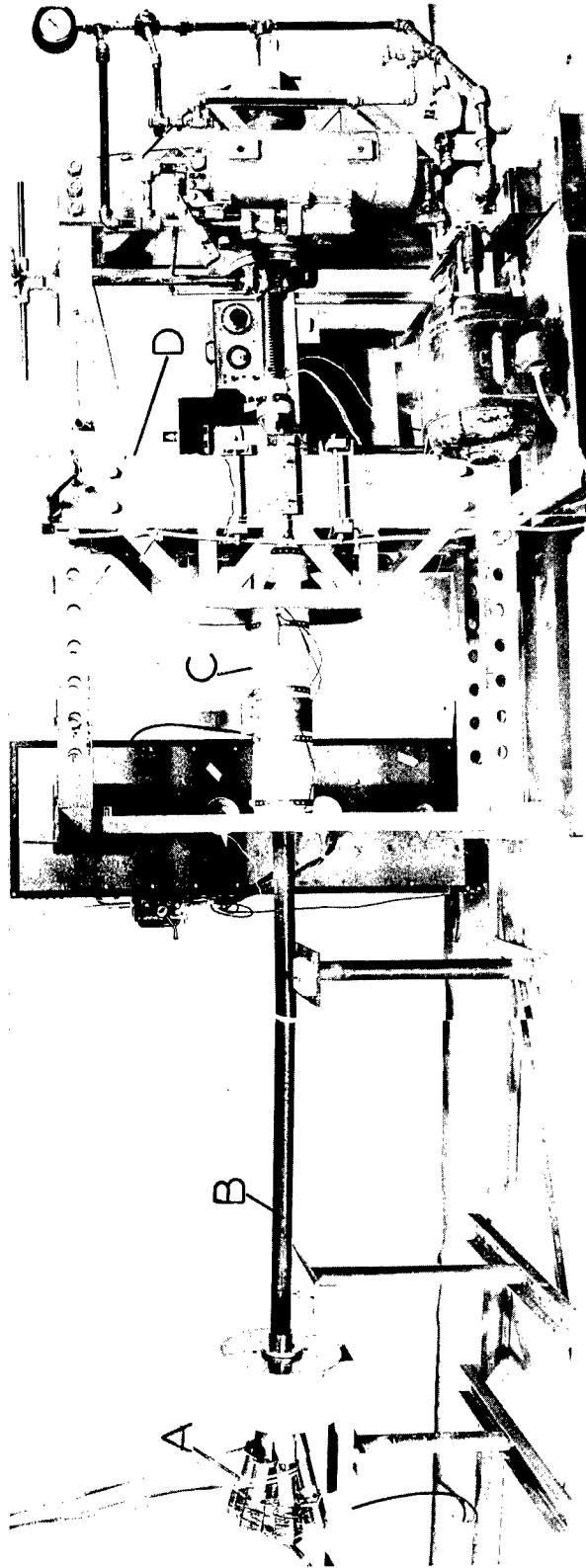

Figure 6

5-KILOWATT MOTOR-ALTERNATOR SET
USED FOR DRIVING ULTRASONIC TRANSDUCER-COUPLING
IN ALUMINUM EXTRUSION CLADDING TESTS



- A. Multidrive system without housing
- B. Ultrasonic coupler rod
- C. Asbestos-jacketed section for heating extruding metal
- D. Arbor press mount turned on side

Figure 7

ULTRASONIC EXTRUSION CLADDING ARRAY ASSEMBLED
FOR PRELIMINARY CHECKOUT WITH FREE LEAD EXTRUSIONS

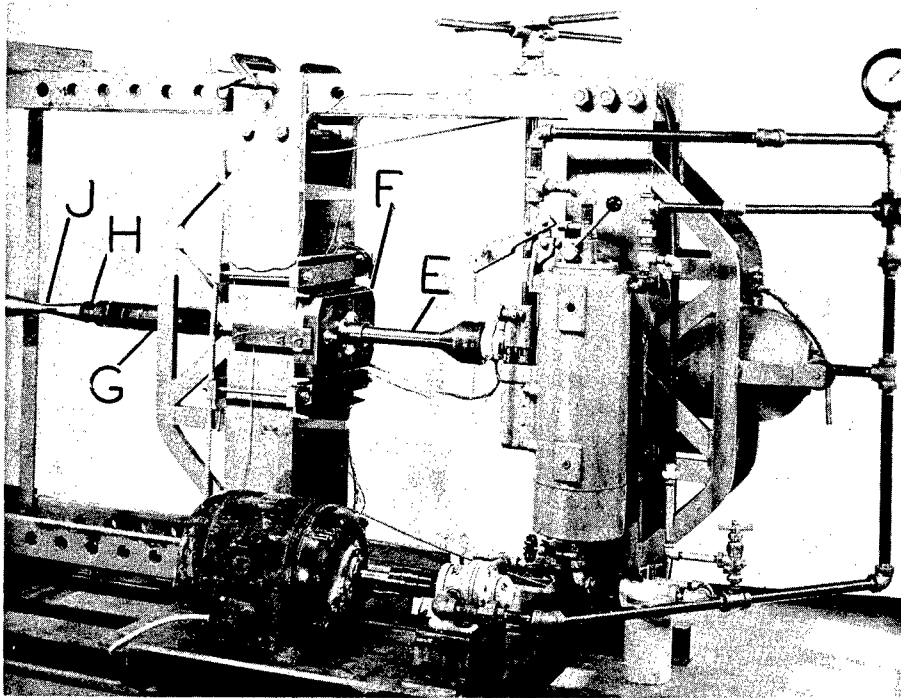

- E. Extrusion ram
- F. Support plate
- G. Standard extrusion container
- H. Container tip and die ring
- J. Necked-down end of ultrasonic coupler replacing die nut

Figure 8

HEAD END OF ULTRASONIC EXTRUSION ARRAY OF FIGURE 7
WITH ASBESTOS JACKET REMOVED

Table I
EFFECTS OF ULTRASONIC ENERGY APPLIED DURING DIRECT EXTRUSION OF LEAD

Test No.	Vibration Applied Intermittently to	Ultrasound Power (watts)	Ultrasound Effect Compared to Non-Ultrasound Extrusion on Same Billet*		Ultrasound Effect Compared to Control Extrusions with No Ultrasound Application*	
			Effect on Ram Speed at Extrusion Force of 7500 lb (%)	Effect on Force at Ram Speed of 10,500 lb (%)	Effect on Rate at Extrusion Pressure of 3.5 tons/sq.in. (%)	Effect on Pressure at Ram Speed of 0.2 in./min (%)
10	Die	200	+47	+76	+227	-25
11	Die	200	+25	+74	+127	-17
12	Ram	200	+33	+13	+104	-16
13	Die	500	+88	+80	+141	-20
16	Container	200	+14	+41	+309	-28

* Effect determined at 2 inches ram-travel position.

Table II

EFFECTS OF ULTRASONIC ENERGY APPLIED
DURING DIRECT EXTRUSION OF ALUMINUM BILLETS

Test No.	Type of Billet	Extrusion Die	Type of Test	Type of Test	Temperature (°C)		Peak Force (lb)		
					Indicated Range	Average at Peak Force	Indicated	Corrected to 525°C	
11	Solid	Shear	Ultrasonic	Ultrasonic	1200-1400	514-532	528	19,200	19,700
12	Solid	Shear	Ultrasonic	Ultrasonic	1200-1400	521-530	525	19,800	19,800
13	Solid	Shear	Control	Control	---	526-537	530	22,200	23,200
14	Laminated	Shear	Ultrasonic	Ultrasonic	1300-1500	516-525	520	18,800	18,000
15	Laminated	Shear	Control	Control	---	528-548	538	19,800	22,200
16	Solid	Shear	Pulsed Ultrasonic	Pulsed Ultrasonic	~1500	514-540	530	25,000	26,000
17	Solid	Conical	Control	Control	---	515-529	523	24,000	23,600
18	Solid	Conical	Ultrasonic	Ultrasonic	1300-1500	507-528	518	23,400	21,900
19	Solid	Conical	Pulsed Ultrasonic	Pulsed Ultrasonic	~1500	520-538	524	23,400	23,200
20	Laminated	Conical	Control	Control	---	510-527	520	24,500	23,500
21	Laminated	Conical	Ultrasonic	Ultrasonic	1300-1500	510-527	519	23,500	22,300

Table III
SUMMARY OF ALUMINUM EXTRUSION CLADDING TESTS

Tube Length: 4-1/2 feet
Temperature: 593°C

Test No.	Cladding on Tube	Billet Length (inches)		Extrusion Force (tons)	Ultrasonic Power (watts)	Range of Tube Speeds (in./min)	
		Start	End			Non-Ultrasonic	Ultrasonic
2	Inside	23	18-3/8	40	1000-1875	0.21-0.51	0.22-0.68
4	Inside	13-3/4	10-1/2	40	750-950	1.00-1.58	1.66-2.46
5	Inside	24-3/16	18-7/8	40	925-1425	0.23-0.94	0.48-2.00
6	Inside	17-3/4	12-7/8	40	1250-1650	0.94-2.13	2.69-3.38
7	Inside	22-5/8	19-7/8	40	None	0.40-0.59	--
8	Inside	19-3/4	17-1/16	44	1300-1500	--	2.50-3.88
9	Inside and Outside	17	12-1/4	Varied	1400	0.69-0.88	0.88-1.25
10	Inside	24-7/8	22-3/8	40	450-2300	0.13-0.31	0.25-0.63

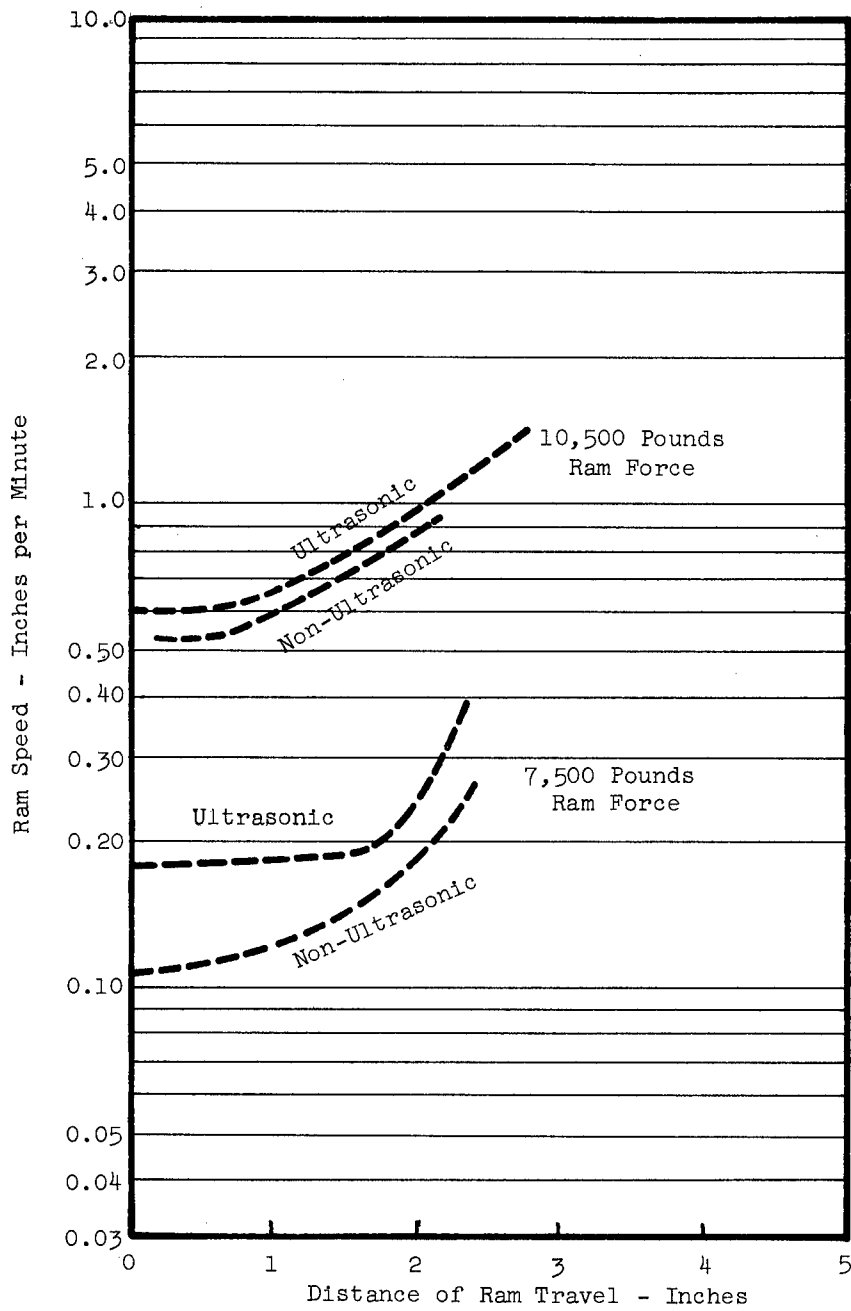

Chart 1

EFFECT OF ULTRASONICALLY ACTIVATED RAM
ON EXTRUSION OF LEAD

Test No. 12

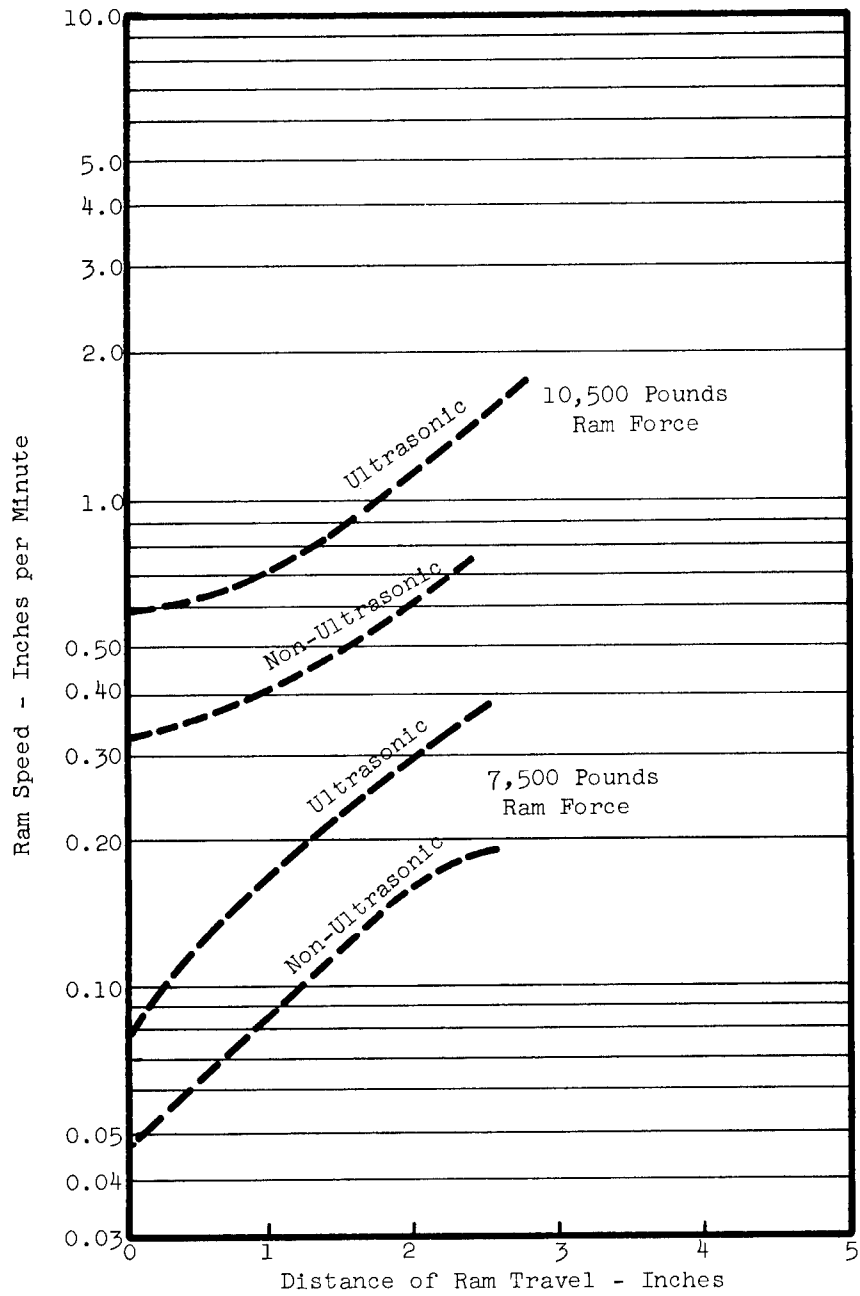

Chart 2

EFFECT OF ULTRASONICALLY ACTIVATED DIE
ON EXTRUSION OF LEAD

Test No. 13

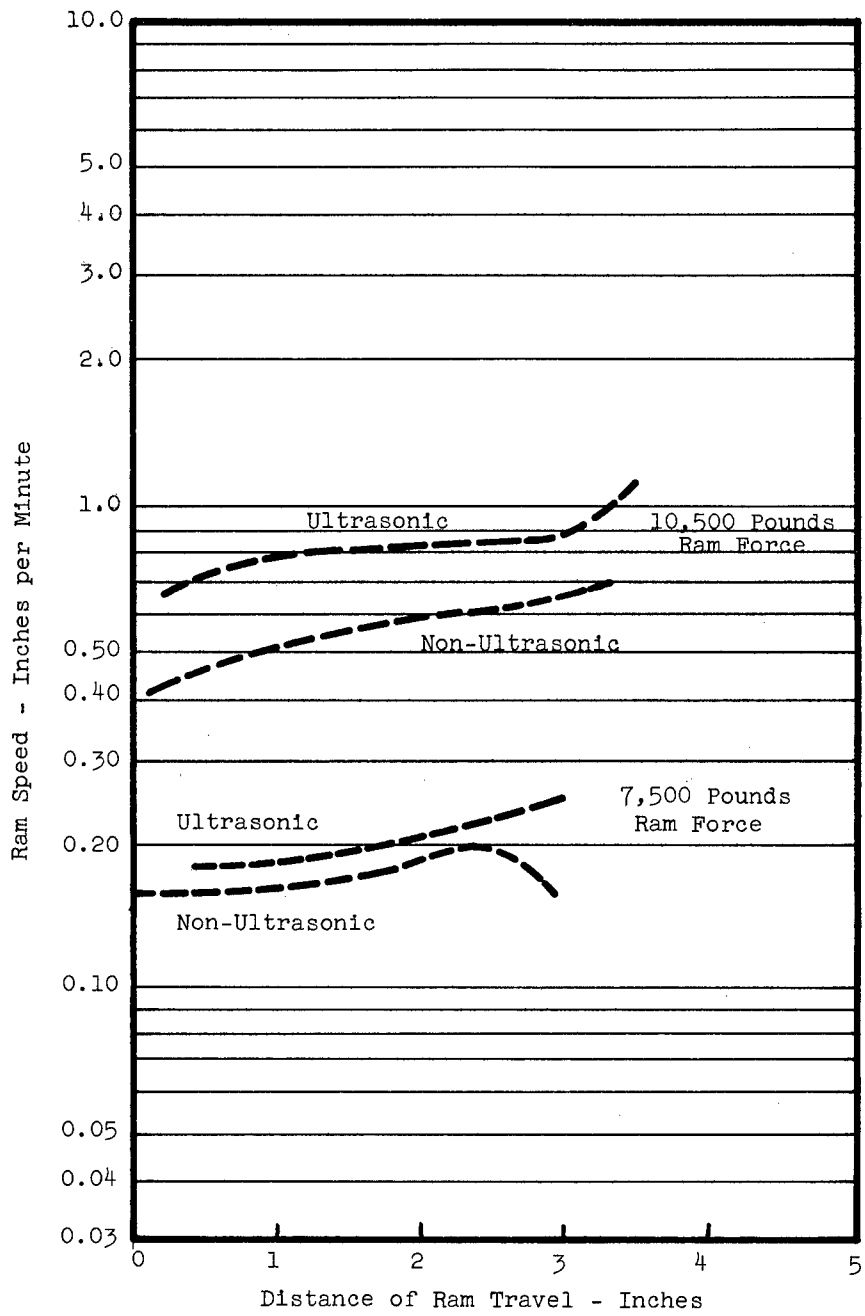

Chart 3

EFFECT OF ULTRASONICALLY ACTIVATED CONTAINER
ON EXTRUSION OF LEAD

Test No. 16

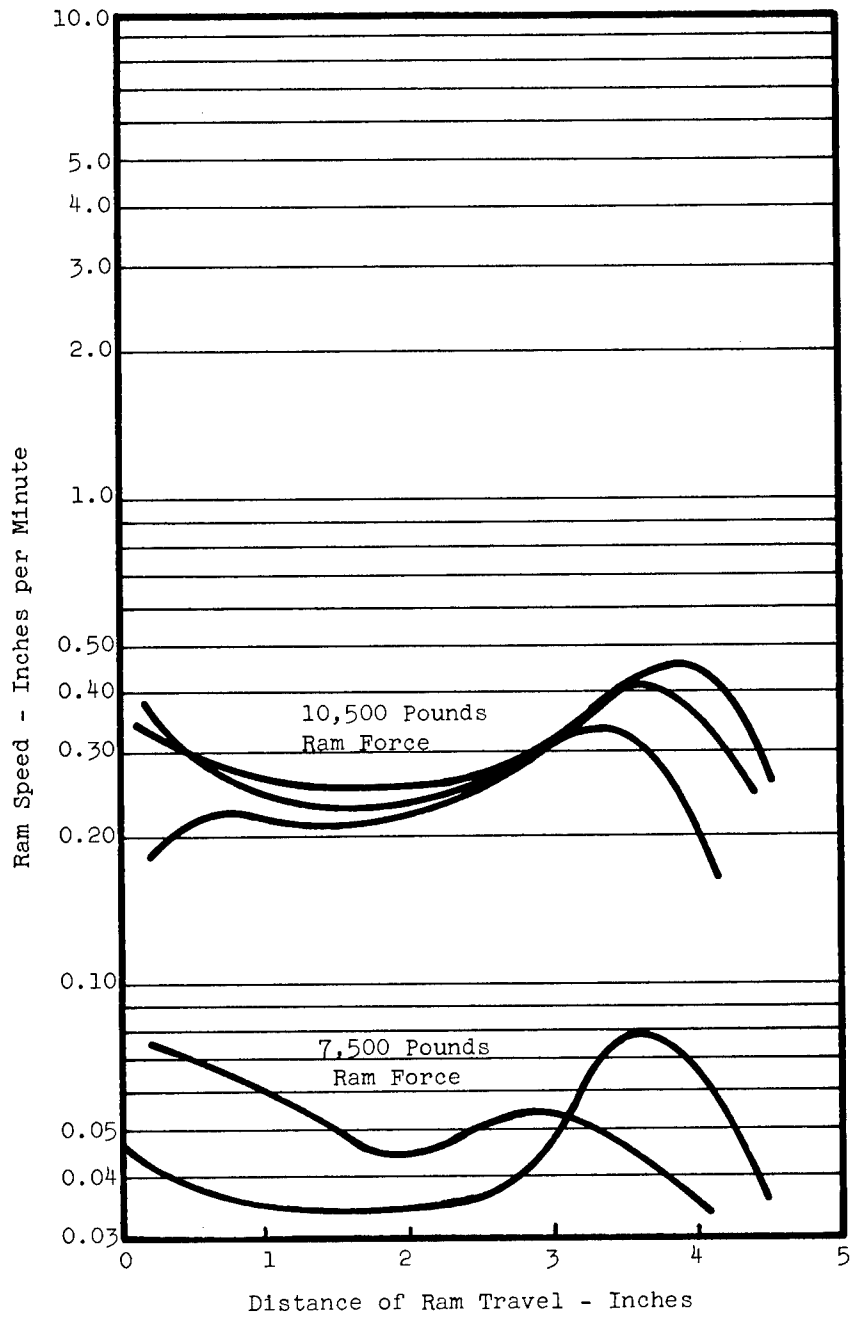

Chart 4

EXTRUSION OF LEAD BILLETS
WITHOUT ULTRASONIC ACTIVATION

Tests 17, 19, 20

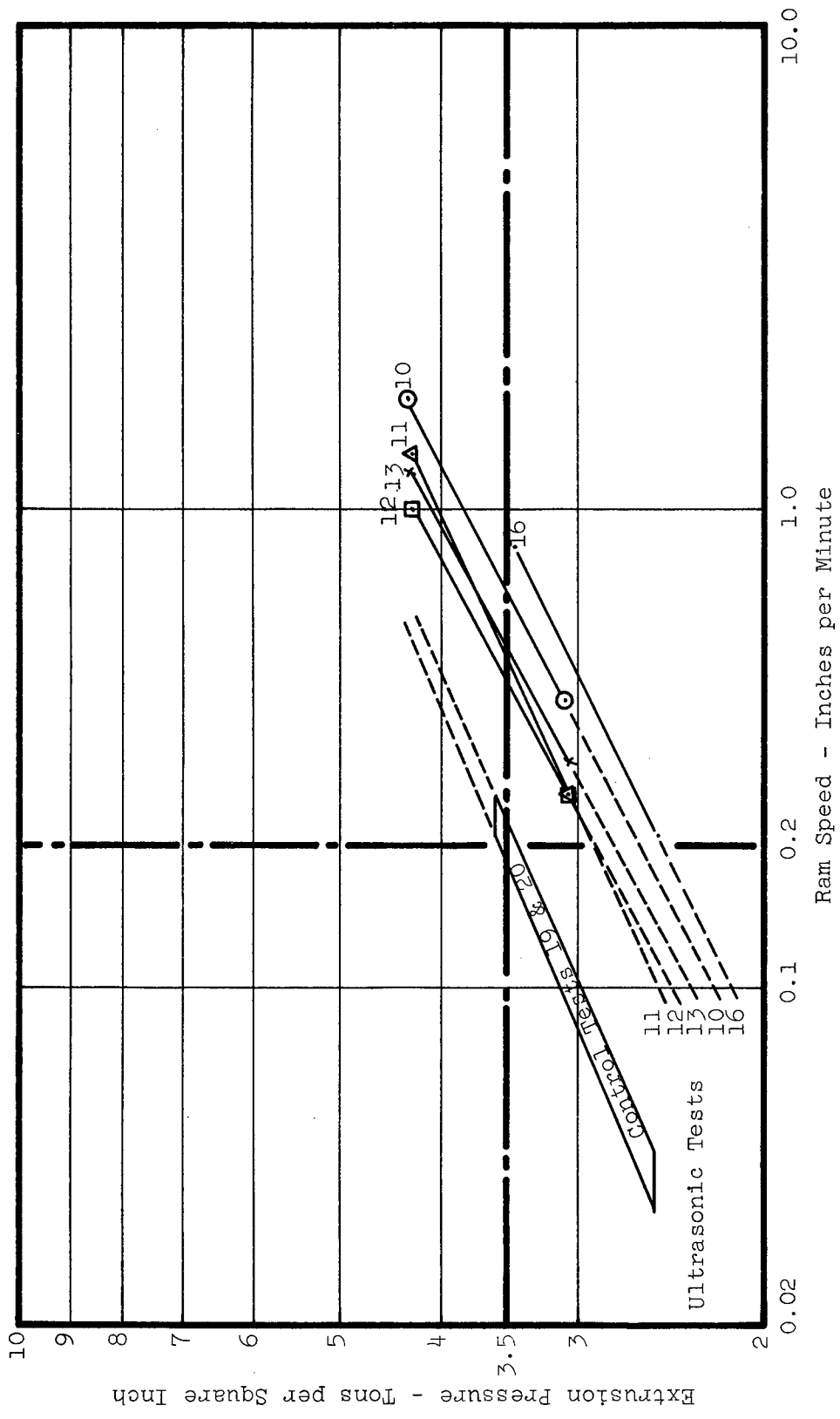

Chart 5
 PRESSURE REQUIRED FOR EXTRUSION OF LEAD
 UNDER UNTRASONIC AND NON-ULTRASONIC CONDITIONS
 After 2 inches ram travel

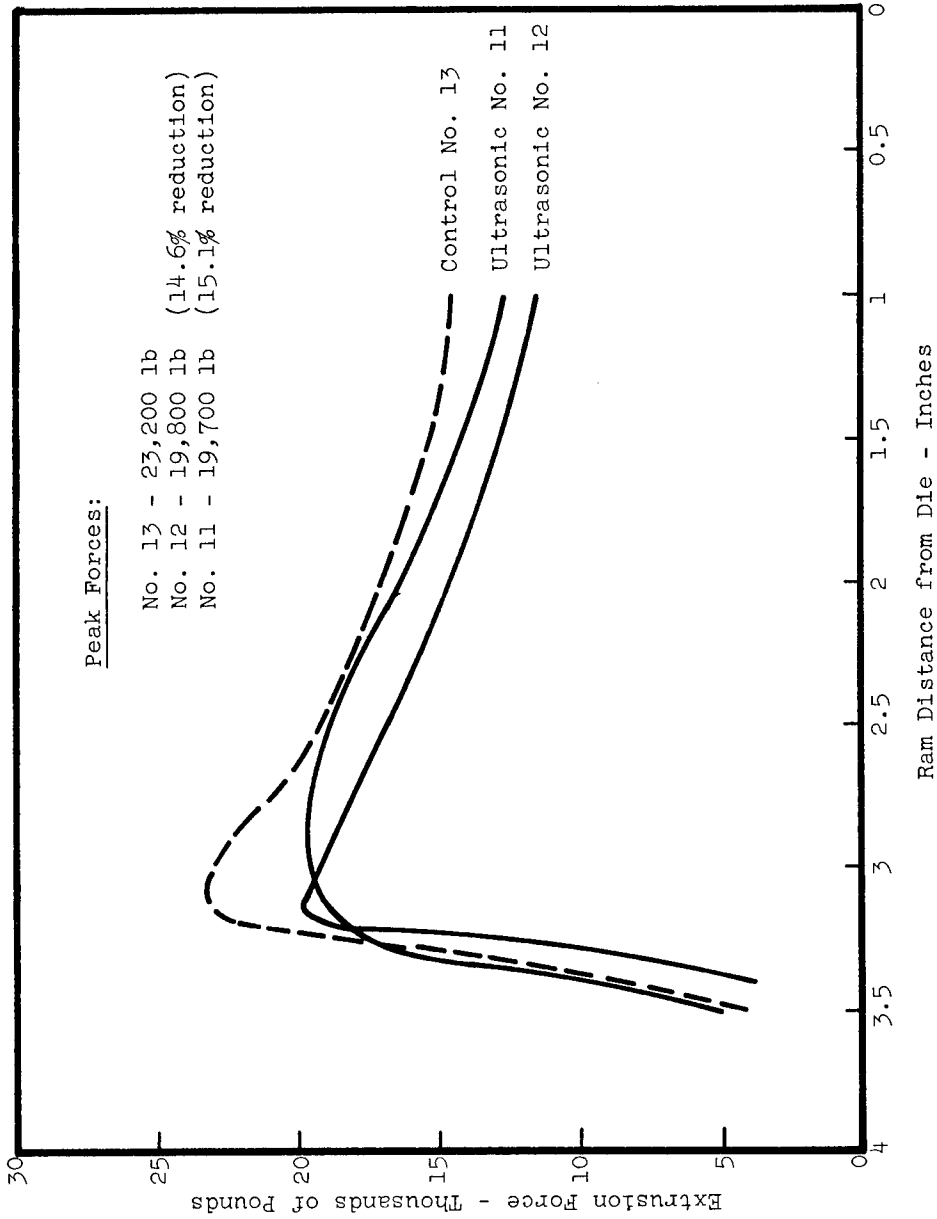

Chart 6

ULTRASONIC EFFECT ON FORCE REQUIRED FOR EXTRUSION
OF SOLID ALUMINUM BILLET WITH SHEAR DIE

Extrusion rate: 2 inches per minute
Ram speed: 0.18 inch per minute

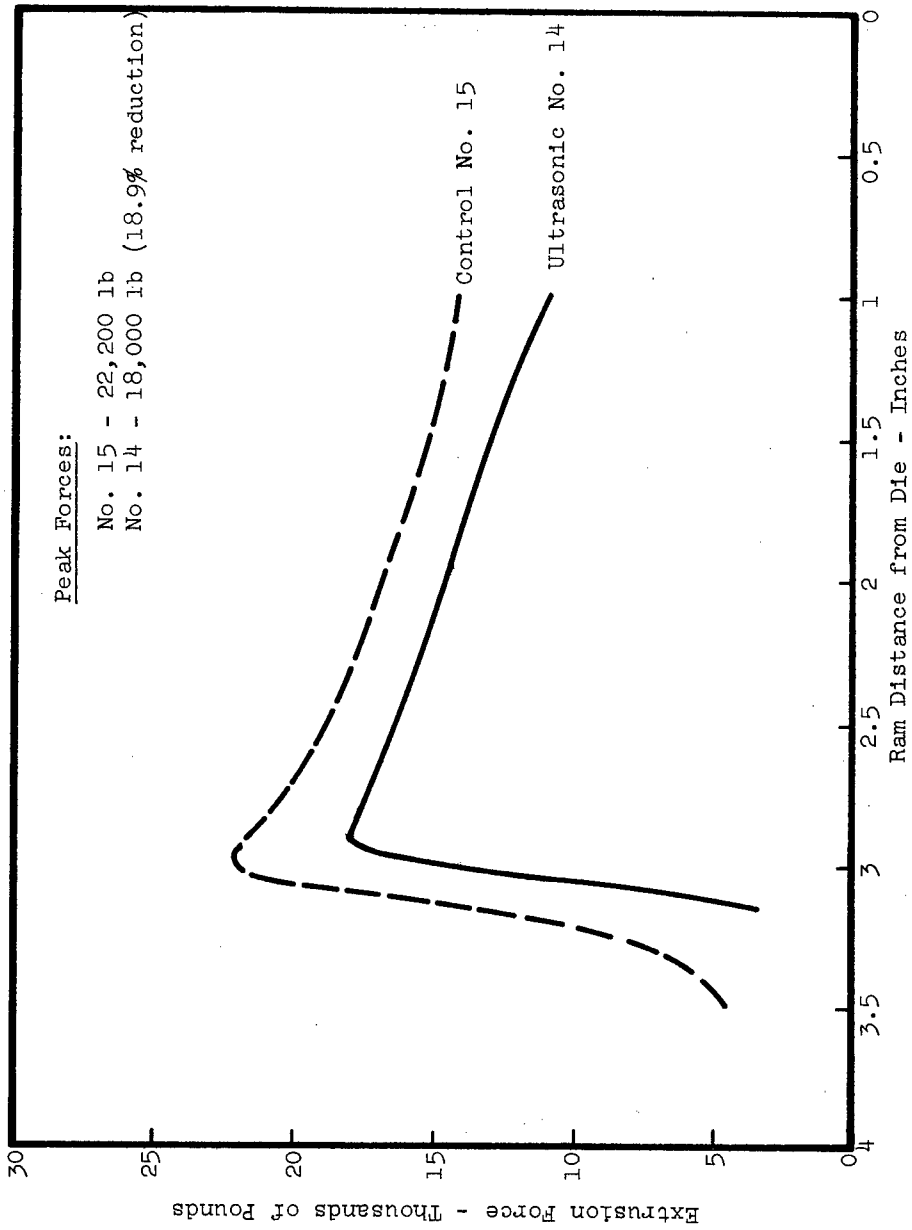

Chart 7

ULTRASONIC EFFECT ON FORCE REQUIRED FOR EXTRUSION
 OF LAMINATED ALUMINUM BILLET WITH SHEAR DIE

Extrusion rate: 2 inches per minute
 Ram speed: 0.18 inch per minute

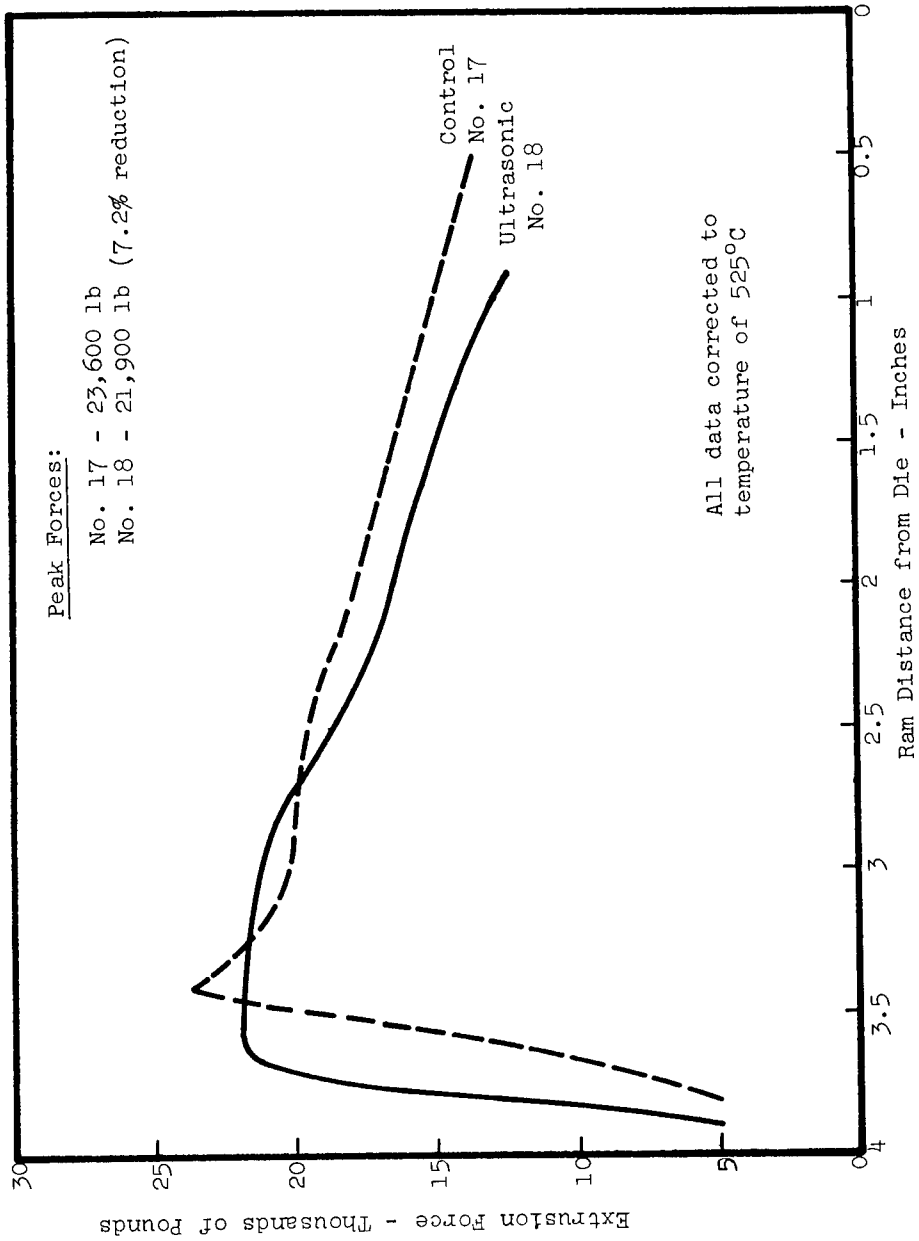

Chart 8

ULTRASONIC EFFECT ON FORCE REQUIRED FOR EXTRUSION
 OF SOLID ALUMINUM BILLET WITH CONICAL DIE

Extrusion rate: 2 inches per minute
 Ram speed: 0.18 inch per minute

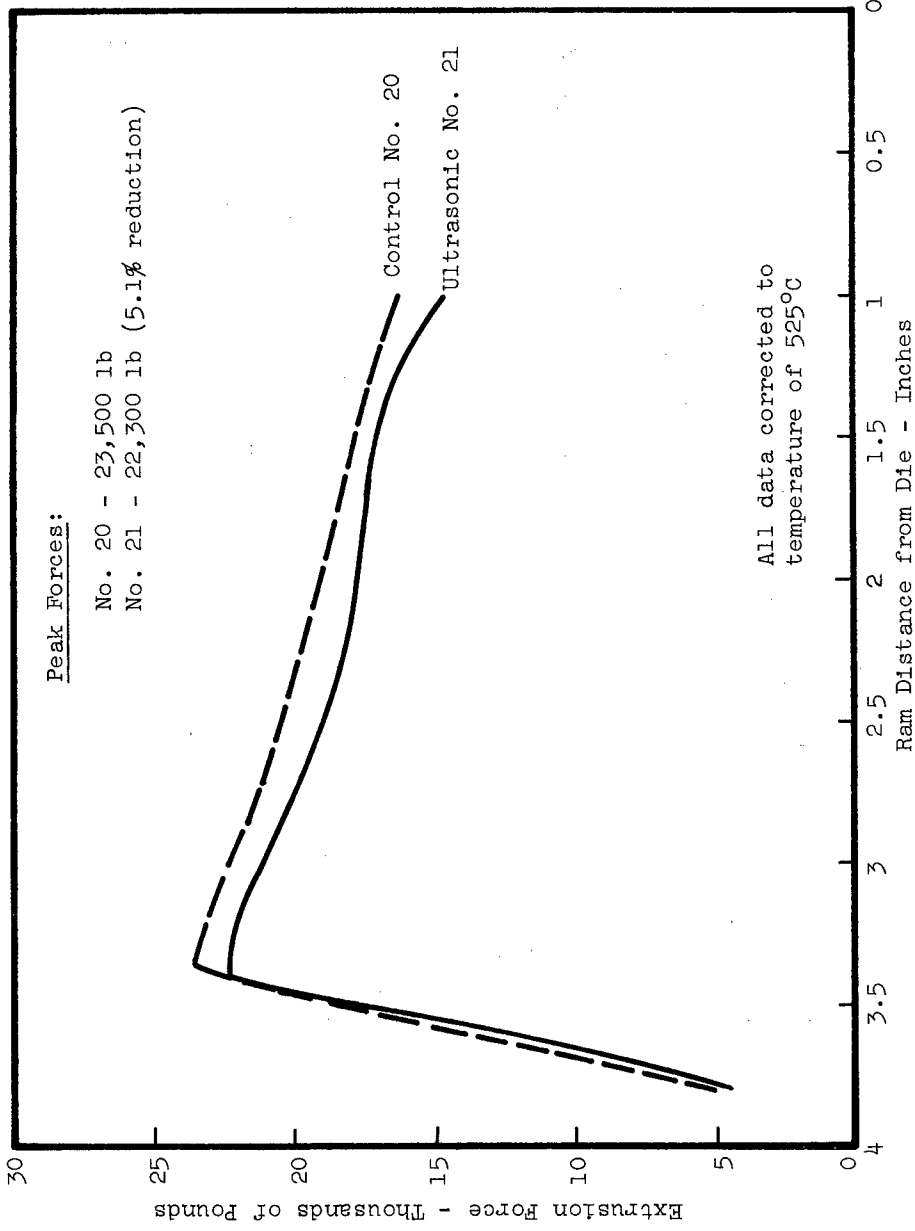

Chart 9

ULTRASONIC EFFECT ON FORCE REQUIRED FOR EXTRUSION
 OF LAMINATED ALUMINUM BILLET WITH CONICAL DIE

Extrusion rate: 2 inches per minute
 Ram speed: 0.18 inch per minute

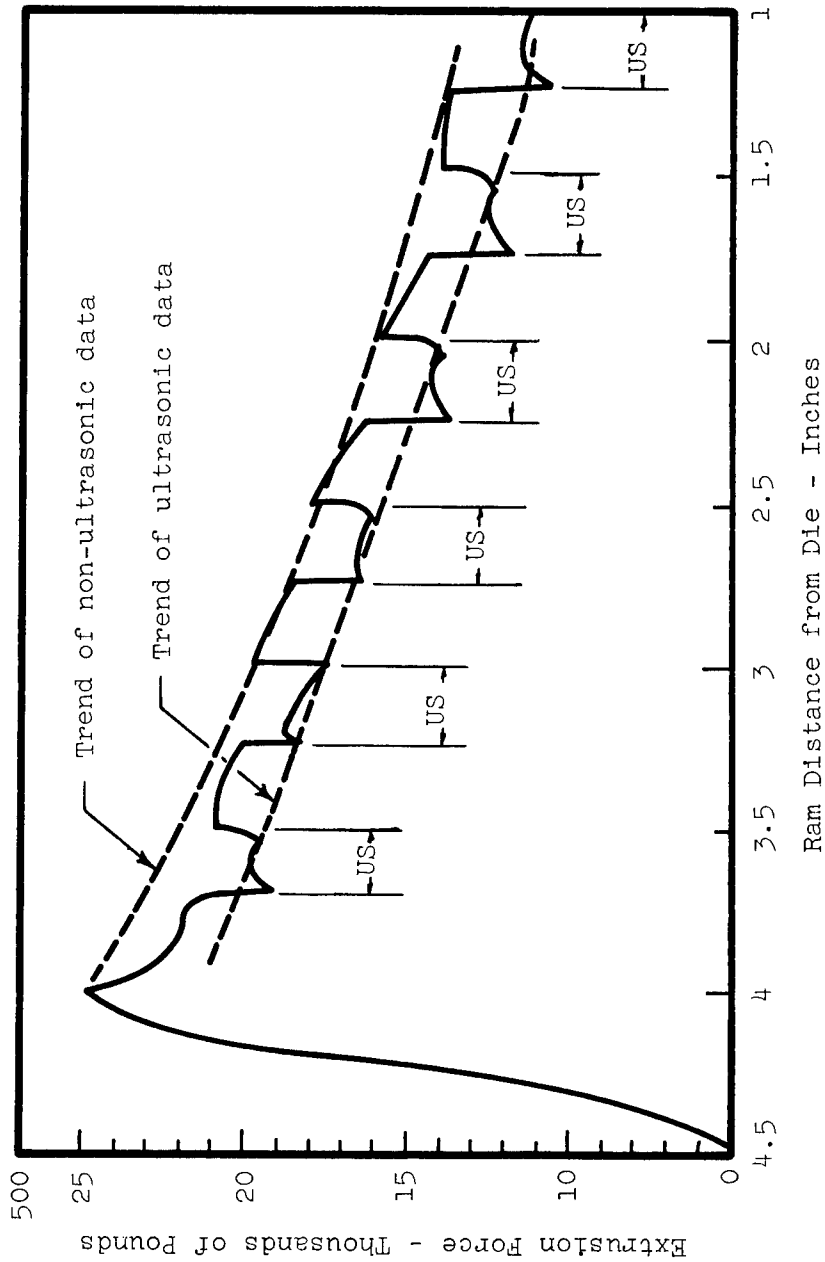

Chart 10
 PULSED ULTRASONIC EXTRUSION OF SOLID ALUMINUM BILLET WITH SHEAR DIE
 Test No. 16
 Extrusion rate: 2 inches per minute
 Ram speed: 0.18 inch per minute
 "US" indicates interval of ultrasonic application

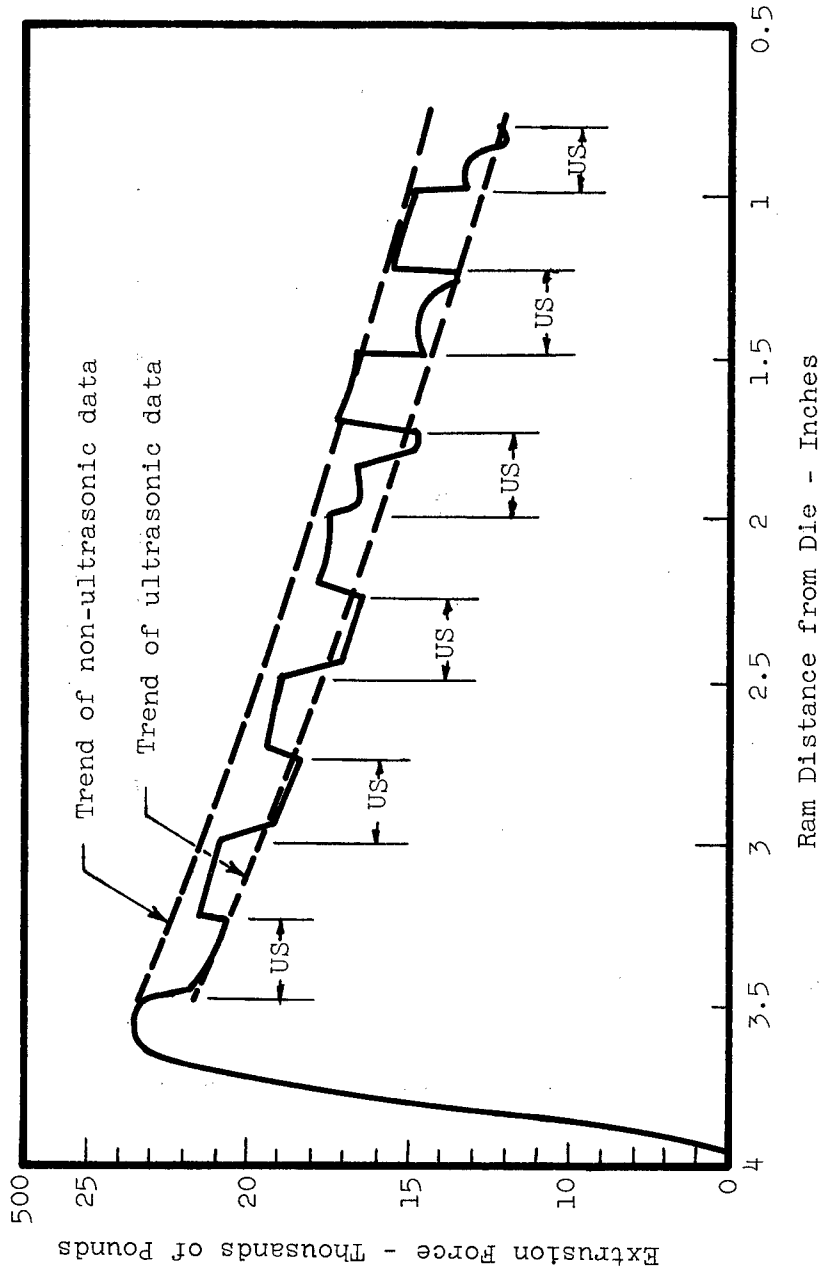

Chart 11

PULSED ULTRASONIC EXTRUSION OF SOLID ALUMINUM BILLET WITH CONICAL DIE

Test No. 19

Extrusion rate: 2 inches per minute

Ram speed: 0.18 inch per minute

"US" indicates interval of ultrasonic application

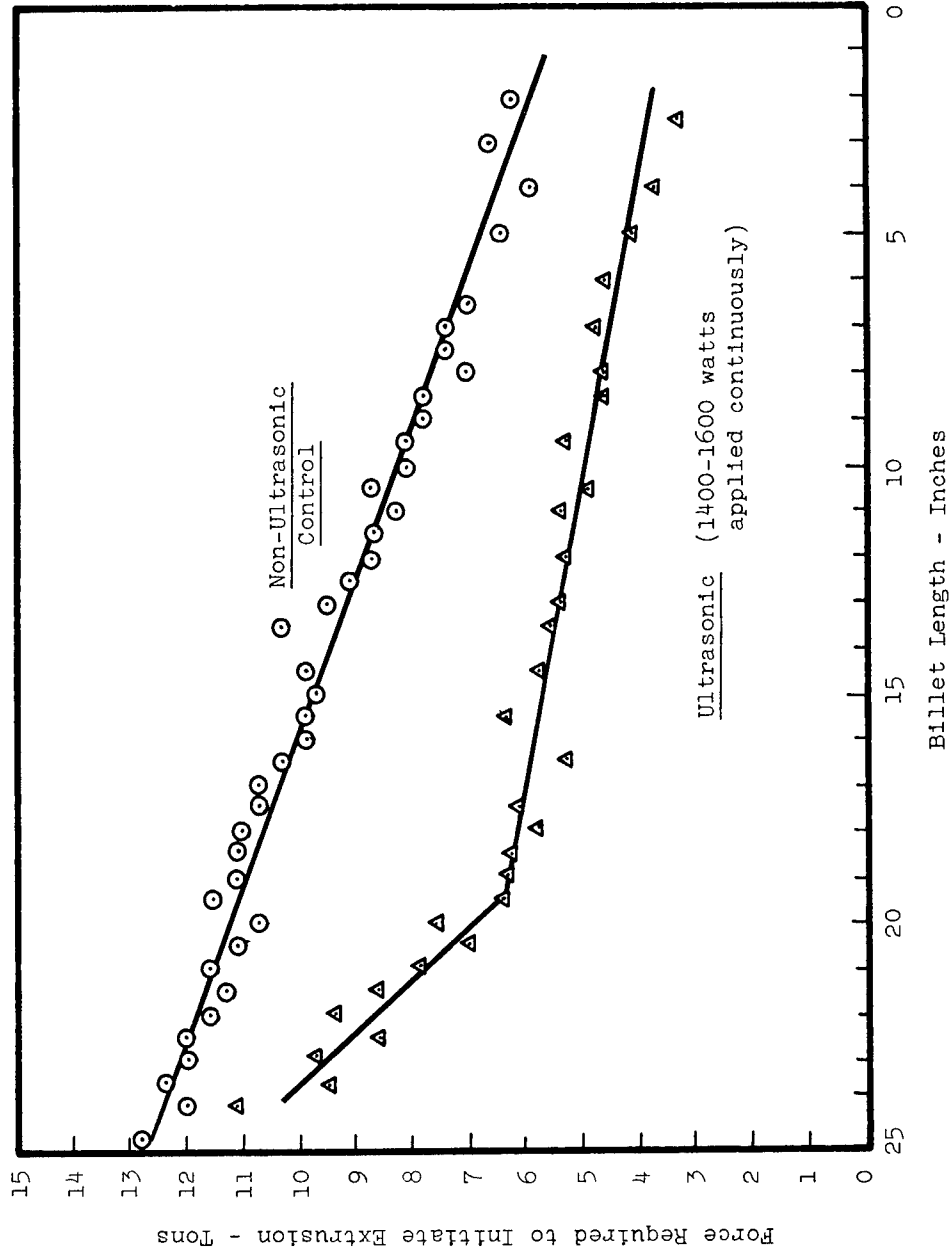

Chart 12

LABORATORY TESTS IN EXTRUSION OF LEAD
 USING ULTRASONIC EQUIPMENT ASSEMBLED FOR FULL-SCALE EXTRUSION CLADDING

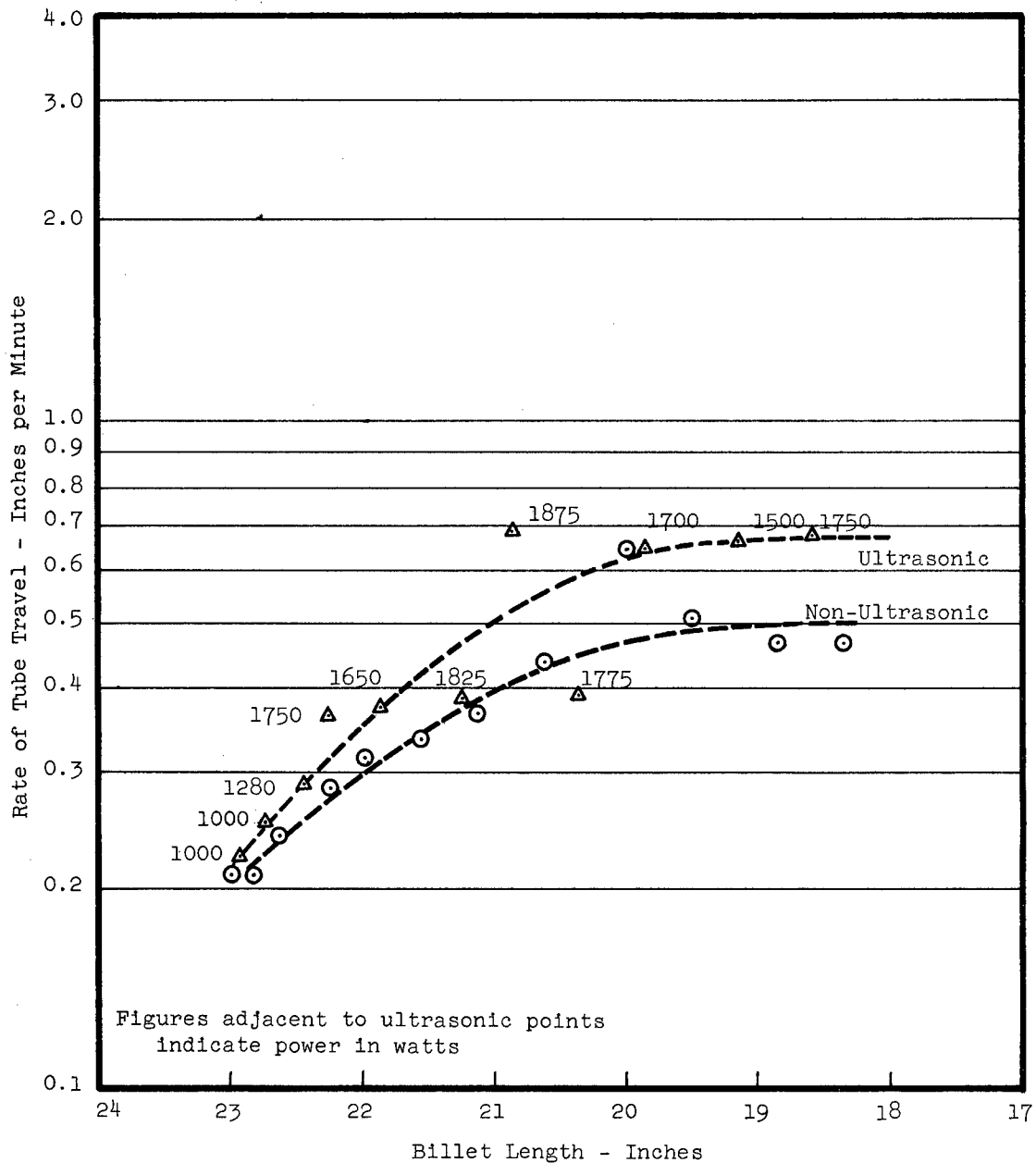

Chart 13

ALUMINUM EXTRUSION CLADDING TEST NO. 2
(Inside cladding only)

Extrusion Force: 40 tons

Ultrasonic Power: 1000-1875 watts

Pulsed at 3 minutes on and 3 minutes off

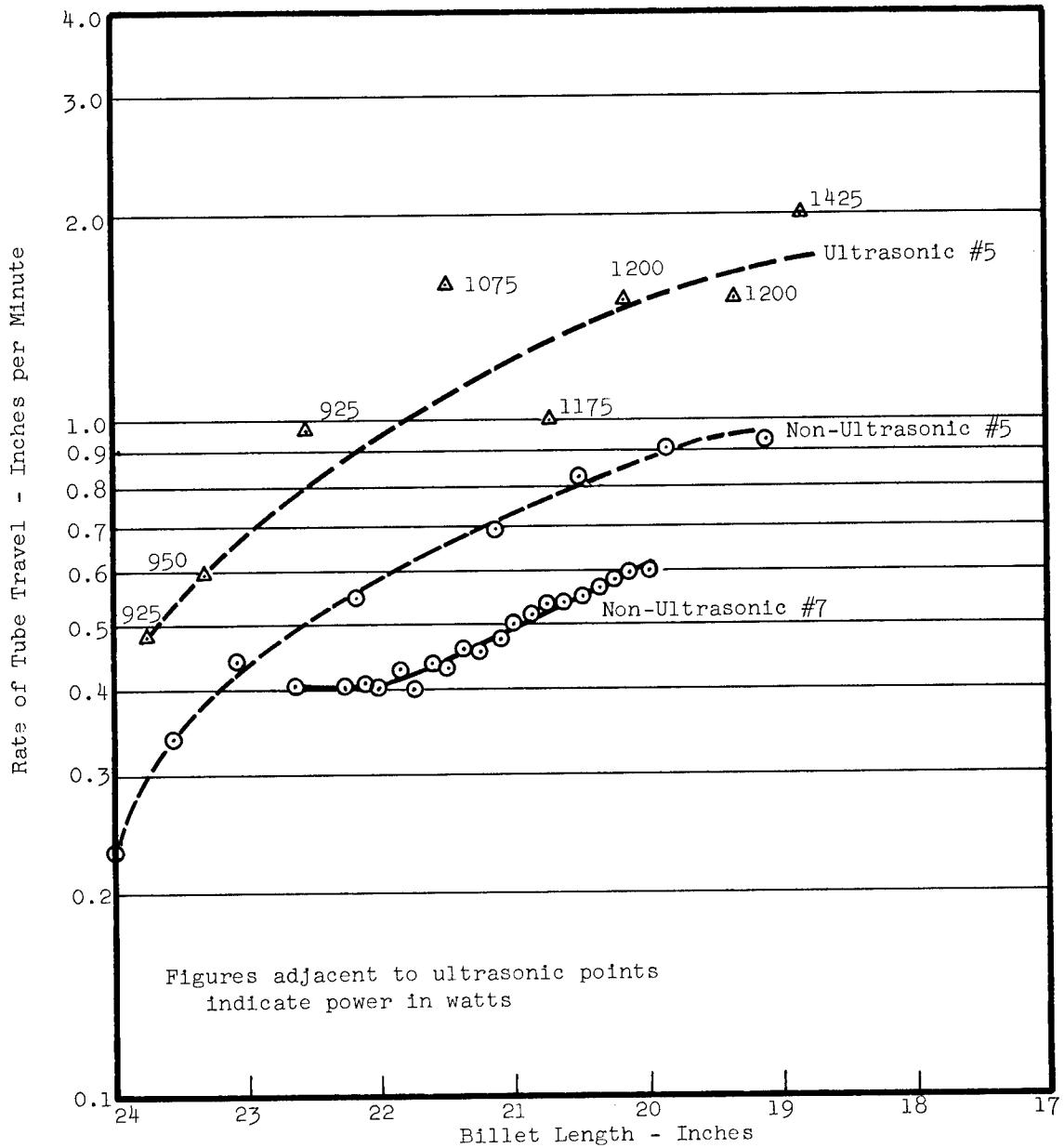

Chart 14

ALUMINUM EXTRUSION CLADDING TESTS NO. 5 AND NO. 7
(Inside cladding only)

- Test No. 5. Alternately ultrasonic and non-ultrasonic
Extrusion Force: 40 tons
Ultrasonic Power: 925-1425 watts
Pulsed at 3 minutes on and 3 minutes off
- Test No. 7. Non-ultrasonic only
Extrusion Force: 40 tons

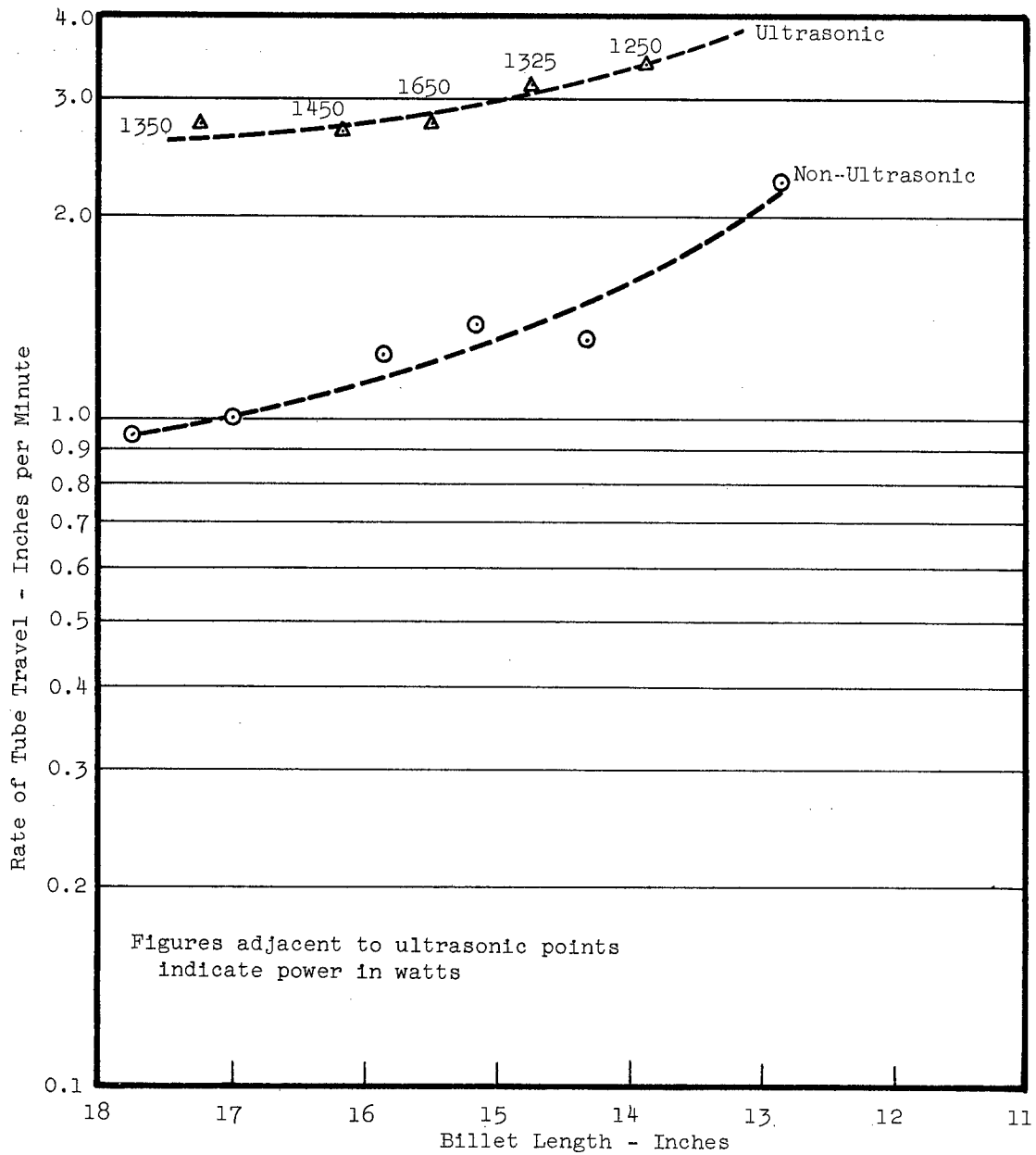

Chart 15

ALUMINUM EXTRUSION CLADDING TEST NO. 6
(Inside cladding only)

Extrusion Force: 40 tons
 Ultrasonic Power: 1250-1650 watts
 Pulsed at 3 minutes on
 and 3 minutes off

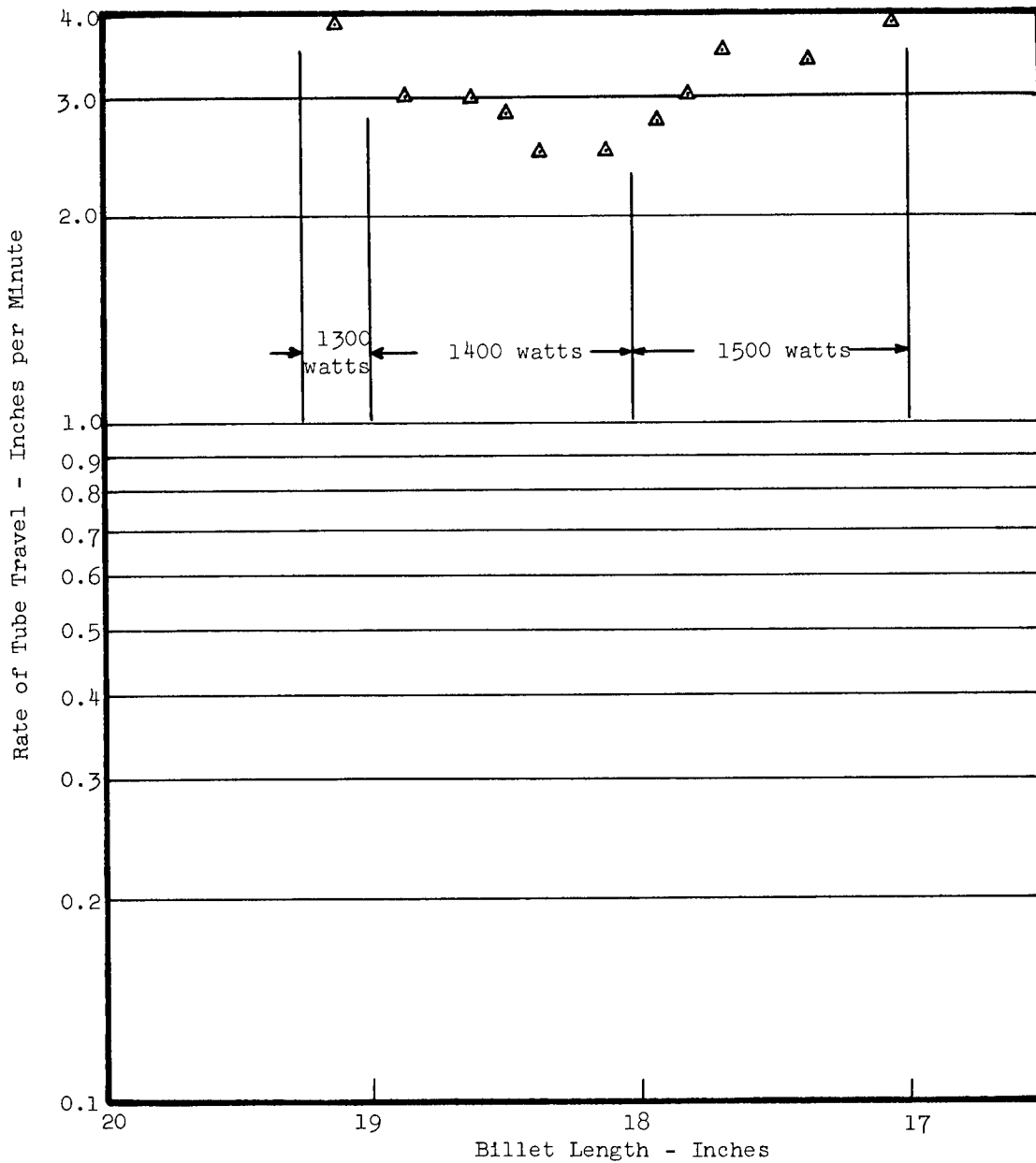

Chart 16

ALUMINUM EXTRUSION CLADDING TEST NO. 8
 (Inside cladding only)

Extrusion Force: 44 tons
 Ultrasonic Power: 1300-1500 watts
 (Ultrasonics applied continuously)

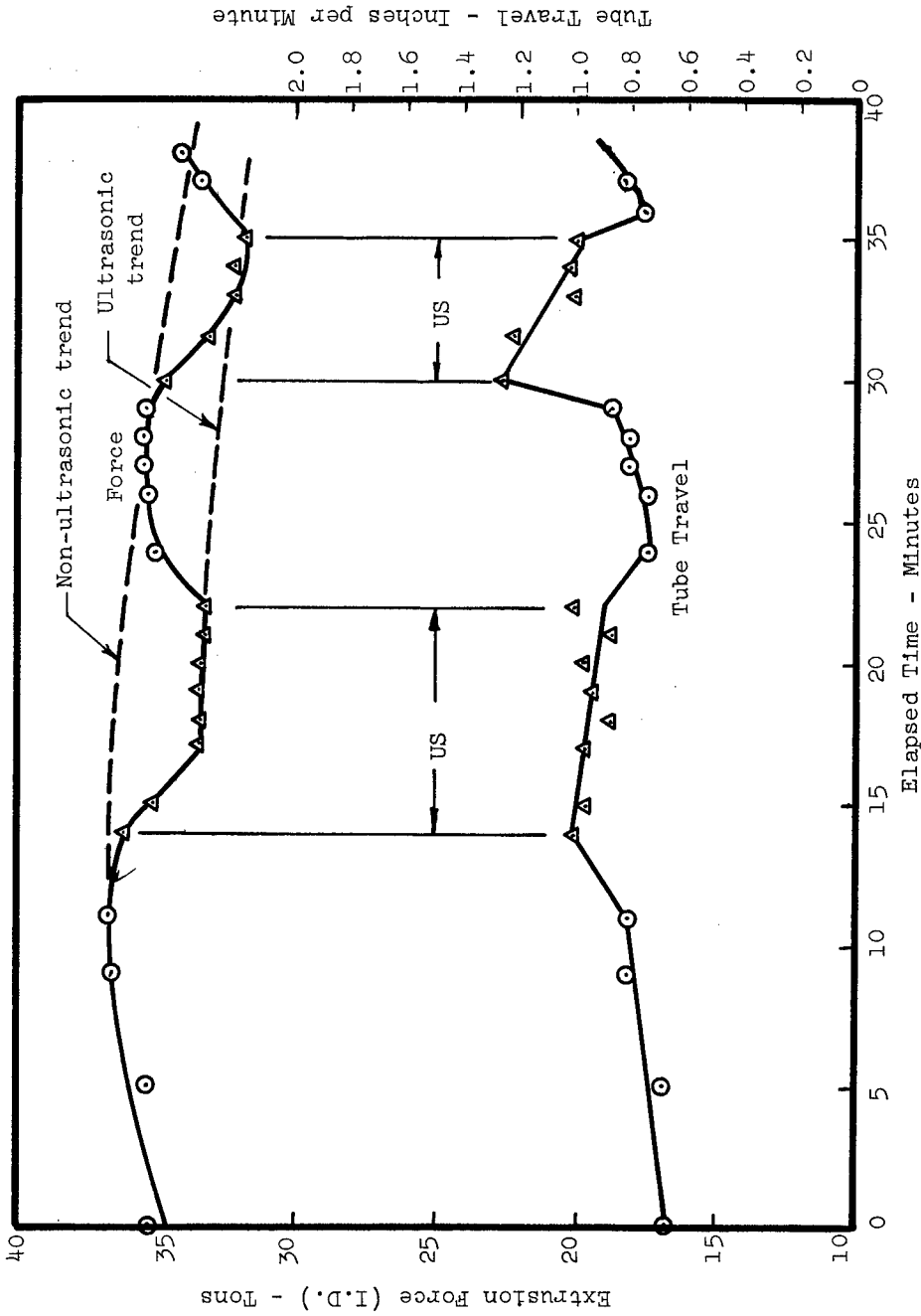

Chart 17

ALUMINUM EXTRUSION CLADDING TEST NO. 9

(Inside and outside cladding)

Ultrasonic Power: 1400 watts

Billet Length: 17 to 12-1/4 inches

UNCLASSIFIED

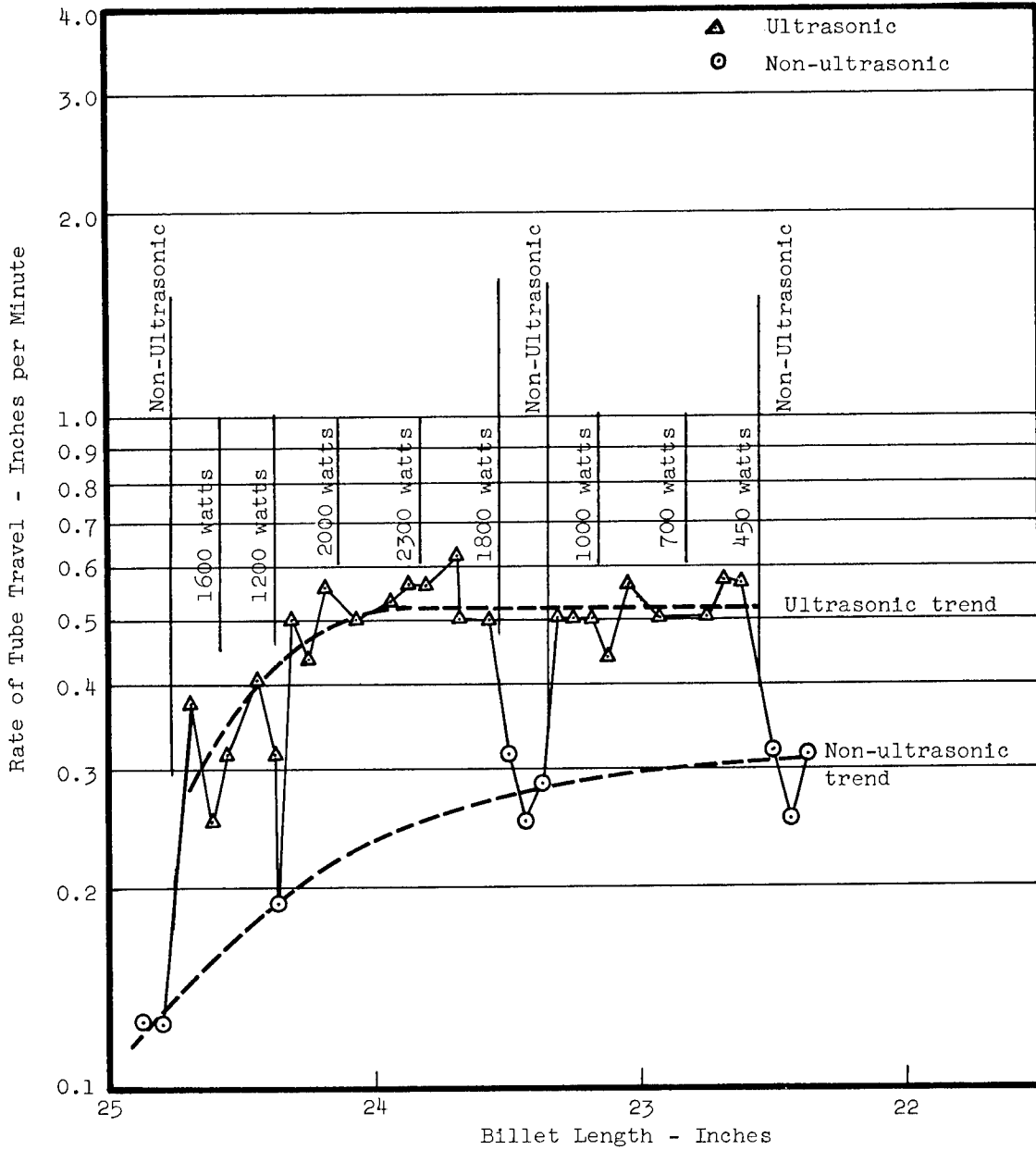

Chart 18

ALUMINUM EXTRUSION CLADDING TEST NO. 10
(Inside cladding only)

Extrusion Force: 40 tons

UNCLASSIFIED