

ERDC/CERL TR-01-65

Construction Engineering
Research Laboratory



**US Army Corps
of Engineers®**

Engineer Research and
Development Center

Applications Guide for Compressed Air Systems

Mike C.J. Lin and Yezin E. Taha

September 2001

20011231 033

ERDC/CERL TR-01-65

Construction Engineering
Research Laboratory



**US Army Corps
of Engineers.**

Engineer Research and
Development Center

Applications Guide for Compressed Air Systems

Mike C.J. Lin and Yezin E. Taha

September 2001

Foreword

This study was conducted for the Headquarters, U.S. Army Corps of Engineers (HQUSACE), under Project 40162784AT45, "Facility Infrastructure Technology"; Work Unit X051 "Compressed Air System Modernization." The technical monitor was Robert Reeves, AMXIS-C, AMC I&SA.

The work was performed by the Energy Branch (CF-E) of the Facility Division (CF), U.S. Army Construction Engineering Research Laboratory (CERL). The CERL Principal Investigator was Dr. Mike C.J. Lin. Literature reference citations shown in work were provided by Dlaram Punwani of Avalon Consulting, Inc, under contract No. DACA42-01-C-0024-0002-BDD. Appendix material was provided by Technology Management & Services, Inc., and by Xenergy, Inc., under contract No. DACA88-98-D-0007-0002. The technical editor was William J. Wolfe, Information Technology Laboratory. Larry Windingland is Chief, CEERD-CF-E, and L. Michael Golish is Chief, CEERD-CF. The associated Technical Director was Gary Schanche. The Acting Director of CERL is Dr. Alan W. Moore.

CERL is an element of the U.S. Army Engineer Research and Development Center (ERDC), U.S. Army Corps of Engineers. The Commander and Executive Director of ERDC is COL John Morris III, EN and the Director of ERDC is Dr. James R. Houston.

DISCLAIMER

The contents of this report are not to be used for advertising, publication, or promotional purposes. Citation of trade names does not constitute an official endorsement or approval of the use of such commercial products. All product names and trademarks cited are the property of their respective owners.

The findings of this report are not to be construed as an official Department of the Army position unless so designated by other authorized documents.

DESTROY THIS REPORT WHEN IT IS NO LONGER NEEDED. DO NOT RETURN IT TO THE ORIGINATOR.

Contents

Foreword	2
List of Figures and Tables	6
1 Introduction	7
Background	7
Objective.....	8
Approach	8
Mode of Technology Transfer	9
2 Compressed Air System Overview	10
Cost of Compressed Air	10
Cost of Air Leaks	10
CA System Parameters	11
Air Basics Translations	13
Compressor Selection Criteria	13
General Guidelines—First Cost.....	14
General Guidelines—Cooling.....	15
Regulation/Controls Applications.....	15
Regulation Basics.....	16
System Location and Arrangement	16
Environmental Factors	17
Ventilation.....	18
Conditions.....	18
Basics for Compressor System Components	18
Moisture Content	19
“Typical” Real World System	20
3 Compressor Types	22
Introduction.....	22
Positive Displacement Compressors	22
Dynamic Compressors	25
4 Compressor Efficiency	27
Single vs. Multiple Stages	27
Single- vs. Double-Acting Reciprocating Compressors	27
Rotary Positive Displacement Compressors.....	27

Centrifugal Compressors.....	28
Lubricant-Free Compressors.....	28
Prime Movers	28
5 Compressor Controls.....	29
Automatic Start-Stop.....	29
Continuous Run—Step.....	29
Continuous Run—Modulating	29
Throttled Inlet.....	30
Variable Displacement.....	30
Variable Speed Drive	30
6 Compressed Air Dryers.....	31
Deliquescent Air Dryers.....	31
Desiccant Air Dryers	31
Internal Heat Reactivated	32
Heatless or Pressure Swing	32
Purge Control System	32
Other Desiccant Drying Systems	33
Refrigerated Air Dryers.....	33
7 Compressed Air Line Filters	34
Cyclonic Separators	34
Particulate Filtration.....	34
Coalescing Filters.....	35
Absorption Filters.....	35
Adsorption Filters.....	35
8 Automatic Condensate Traps	36
Internal Pilot-Actuated Diaphragm Valves.....	36
Floating Seal Valves	37
Motorized Ball Drain Valves	37
9 Compressed Air Condensate Separators.....	38
Gravity Separators with Carbon After Filters.....	38
Gravity Pre-Separation with Coalescing Filters and “Carbon After Filters”	38
Membrane Separation (Ultrafiltration)	39
Membrane Separation (Nanofiltration)	39
Distillation Type	39
10 Compressed Air Distribution System.....	40
Centralized	40
Departmental	41
Suction Pipe	41

Pipe Strain	41
Air Receiver	41
Drip/Drop Legs	42
Pressure Drop	42
11 Determining Compressed Air Requirements	44
Anticipating Future Requirements	44
CA Receiver	45
12 Compressed Air System Audit	46
Level of Air Treatment	47
Leaks	47
Pressure Levels	47
Controls	48
Heat Recovery	48
Distribution System	48
Load Profile	48
End-Use Equipment	48
Compressor Package	49
Filters	49
Aftercooler	49
Expansion/Economy	49
Air Receiver/Storage	50
More Comprehensive Evaluations	50
13 Compressed Air System Optimization	51
Design	51
Supply Management	51
Demand Side Management	52
Waste Management	52
Heat Recovery	53
References	54
Glossary	66
Appendix A: Compressed Air System Survey at Picatinny Arsenal	71
Appendix B: Compressed Air System Survey at Watervliet Arsenal	88
CERL Distribution	107
Report Documentation Page	108

List of Figures and Tables

Figures

1	Ideal components layout	19
2	Reciprocating air compressors.....	23
3	Rotary screw air compressors.....	24
4	Rotary sliding vane.....	24
5	Rotary blower	26
6	Centrifugal air compressor	26
7	Centrifugal impeller	26
A1	Potential savings due to reductions in air leaks and the level of production air supplied during nonproduction periods	72
A2	Picatinny CA flow and pressure.....	76
B1	Main air system operating costs.....	90

Tables

A1	Load profiles and power usage assessments for main compressed air systems at Picatinny Arsenal.....	76
A2	Costs associated with tube / nozzle change to alter blowoff configuration	87
B1	Surveyed air compressor performance characteristics	92
B2	Estimated air compressor performance characteristics	92
B3	Estimated energy costs — current and proposed systems (all shifts)	93
B4	Energy cost summary.....	94
B5	Key performance characteristics by compressor type	98
B6	Costs and savings associated with implementing a leak management program	105

1 Introduction

Background

Compressed air (CA) is commonly used as a source of power for tools, industrial processes, and equipment. Users often consider CA as a "fourth utility"—after electricity, gas, and water. Most frequent use of CA include shop air, pneumatic control systems, instrument and spray air, factory lab systems, outdoor and pneumatic transport of materials, and breathing air. In most industrial plants and shops, CA is centrally generated and distributed to all users through a pipe network.

Although CA is a very convenient power source, CA systems are not cheap to operate. The annual cost of electricity needed to run the air compressor can approach (and even exceed) the initial cost of the compressor itself. A large part of these high energy costs can be attributed to recoverable losses. For example, about 20 percent of the power input to the compressor is rejected as heat. Cooling of the air compressor represents 5 percent of generation costs. Air leaks are often the largest waste of energy associated with CA usage, sometimes totaling 30 percent of the total compressor output. Other costs (yearly maintenance charges, labor, and materials) must be added to energy costs to arrive at the true cost of CA. An analysis of the cost breakdown of a CA system shows that as little as 10 percent of the input power supplied to the compressor is delivered as CA to the system. This means that, at an average electricity cost of 5 cents/KWh, the equivalent cost of CA to the "end-of-pipe" user is approximately 50 cents/KWh.

In fact, such high costs are the result of poor (or poorly planned) system management. A properly managed CA system can save energy, decrease downtime, reduce maintenance, increase productivity, and improve the quality of service the system can deliver. With proper management, nearly all industrial plants can realize 25 to 40 percent savings on the power costs for the CA system with-

out additional capital expenditures.* The key to achieving such savings lies in education (understanding the CA system), and proper operation and maintenance. This work was undertaken to provide basic guidelines that both explain CA system operation and methods to improve system efficiency.

Objective

This objective of this work was to create an applications guide for CA system operation and maintenance that would explain the basics of industrial compressed air systems, with an emphasis on the various terms and considerations for more efficient system operation.

Approach

1. A literature search was done to gather current, complete information on compressed air systems. The information is categorized in this report as follows:
 - a. Chapter 2 gives a general overview of compressed air systems.
 - b. Chapters 3 and 4 describe compressor types and efficiencies.
 - c. Chapter 5 describes typical compressor controls.
 - d. Chapters 6 through 10 describe system components including dryers, line filters, condensate traps, oil/water separators and distribution piping are shown with their functions specified.
 - e. Chapters 11 through 13 summarize how to determine the amount of compressed air required and how to conduct system audit and optimization are then provided, followed by a comprehensive list of references and glossary of terminology.
2. Compressed air system surveys were conducted at Picatinny Arsenal, NJ (summarized in Appendix A to this report), and Watervliet Arsenal, NY (summarized in Appendix B).

* Henry L. Kemp, Jr., Strategic Air Concepts, <http://www.strait-air.com/index.html> (qualified instructor for the Compressed Air Challenge program).

Mode of Technology Transfer

This guidebook will be furnished to the AMC base and headquarters personnel in charge of compressed air system operations, and will also be published via the World Wide Web at URL:

<http://www.cecer.army.mil/>

2 Compressed Air System Overview

Cost of Compressed Air

As a good approximation, typical compressor produces:

4 cubic foot per minute (CFM) per 1 motor hp (horsepower)

where:

$$1 \text{ hp} = 0.746/0.9 = 0.829\text{kW}$$

Therefore:

$$1 \text{ CFM} = 0.207\text{kW}$$

and, at \$0.05/kW-hr:

$$1 \text{ CFM} = \$0.0104/\text{hr}$$

Thus, 10 CFM over 8000 hours per year costs:

$$1 \times 8000 \times 0.0104 = \$83.20.$$

Cost of Air Leaks

Air leak represents one of the major costs of compressed air. Establishing a proactive leak detection and repair program is essential to reduce leaks to less than 10 percent of compressor output. Calculations for standard plant air system generally assume:

- 8000 hrs per year operation
- Electrical costs = \$0.05/kWhr,
- Plant line pressure = 100 PSIG,
therefore, the total cost assuming that one (1) 1/8-in. air leak = 26 CFM
would be:

$$26 \times 8000 \times \$0.0104/\text{hr} = \$2163$$

- A typical plant can have air leaks equals to 20 percent of total air usage.
- Air leak can be calculated as follows:

$$\text{Leakage (CFM free air)} = V \times (P_1 - P_2) / t \times 14.7 \times 1.25 \quad \text{Eq 1}$$

where:

V = the system volume in cubic feet

P₁ = the operating pressure in psig

P₂ = the pressure after time t (in minutes) and should be a point equals to about one-half the operating pressure P₁

The 1.25 multiplier corrects leakage to normal operating pressure, allowing for reduced leakage with falling pressure.

CA System Parameters

Three main parameters need to be considered in the compressed air system:

1. Pressure
2. Capacity
3. Horsepower.

Pressure (psi, or pounds per square inch):

Description

System pressure depends on user requirements, controls, and safety valves.

An unregulated compressor will keep increasing pressure until a failure occurs.

When plant capacity demand exceeds system capacity (CFM), compressor discharge pressure will drop.

The Pressure - Capacity relationship is expressed as:

$$P_1 \times V_1 = P_2 \times V_2 \quad \text{Eq 2}$$

where:

P₁ = Initial pressure

V₁ = Initial capacity

P₂ = Final pressure

V₂ = Final capacity.

If a system needs more capacity (CFM) than available, plant pressure drops in an unsuccessful trade of pressure for capacity.

The Cost of Pressure

A good "rule of thumb" in calculating the cost of pressure is:

$$\text{Each pound (psi) of system pressure} = 0.5 \text{ percent of system horsepower} \quad \text{Eq 3}$$

For example, one might calculate pressure cost as follows:

Assume that a 100-hp compressor is set to discharge at 125 psig to the plant system, and that the plant system only requires 110 psig. If the user resets the compressor discharge pressure to 110 psig (a 15 psi reduction), then the excess consumption can be calculated as:

$$15 \text{ psi} \times 0.5\% = 7.5\% \text{ of hp} = 7.5 \text{ hp}$$

and savings can be calculated as

$$7.5 \times 0.746/.85 = 6.6\text{kW} \times 8000 \text{ hrs} \times \$0.05/\text{kWhr} = \$2633 \text{ (savings per year)}$$

Capacity (Flow, in CFM)

Description

Most capacity measurements are referred back to inlet conditions. Capacity varies only slightly with a change in discharge pressure, for a given compressor model

Capacity Measurement:

In the pneumatics industry, all capacities are measured in reference to inlet conditions. It is important for users to require vendors to define which unit of measurement they use, and where (under what conditions) since various formulae are used to define capacity (CFM):

- SCFM (standard)
- ACFM (actual)
- ICFM (inlet)
- FAD (free air delivery).

American Society of Mechanical Engineers (ASME) and the Compressed Air and Gas Institute- Europe Committee of Compressors, Vacuum Pumps & Pneumatic Tools (CAGI-PNEUROP) have generally accepted testing standards.

Tolerances

Capacity tolerances may vary from vendor to vendor. Users should request the vendor to define its unit(s) of tolerance.

Horsepower

Typically, electric motor nameplate displays a horsepower (hp) number. For natural gas-driven engine, the nameplate will generally also display the MCHP(Max Continuous hp), that is, the work it takes to compress "X" CFM up to "Y" psi. Motor driver hp is usually fixed. If either CFM or psi is increased, the driver may overload, unless regulation, a speed reduction, or a change in either CFM or psi takes place. Horsepower tolerances may vary from vendor to vendor. The user should request a definition of horsepower tolerances from the vendor.

Air Basics Translations

Capacity (CFM) does the work. Pressure affects the rate at which the work is done. A trending decrease in plant air pressure typically indicates a requirement for more capacity (CFM), not for more pressure. Increasing or decreasing the existing compressor discharge pressure will normally have negligible effect on the compressor capacity.

Compressor Selection Criteria

In selecting a compressor, the user should consider the following criteria:

- first cost
- efficiency
- controls
- maintenance
- cooling
- air quality
- durability.

General Guidelines—First Cost

Single-Stage Rotary Screw

Single-stage, rotary screw compressors have the following characteristics:

- typically, the lowest first cost
- greatest market growth, largest population
- typically, the lowest efficiency.

Possible alternatives to single-stage, rotary screw compressors are:

- two-stage rotary screw
- oil free rotary screw (depending on air quality requirements)
- centrifugal (depending on air quality requirements).

Centrifugal Compressors

The advantages of centrifugal compressors are that:

- They are only the real option over 600 hp.
- They can maintain high air quality (0 ppm oil carryover).
- They operate at moderate to high efficiency.
- They have a longer design life than rotary-screw compressors.

The disadvantages of centrifugal compressors are that:

- They have a higher initial cost than rotary-screw compressors.
- They are fluid cooled only.
- They operate at constant speed with limited range of flow (and are unstable beyond this range).

Reciprocating or Rotary Screw Designs

Reciprocating or rotary screw designs are distinguished by the following characteristics:

- constant CFM; variable pressure
- adaptable to variable speed drive
- variable speed and unloading provide close alignment with system demand.

Rotary Screw (Oil Flooded- Single Stage)

Oil Flooded Rotary Screws are the “design of choice” for natural gas engine driven air compressors (NGEDAC’s). Their advantages are that:

- They have a low first cost.
- They have low maintenance costs.

- They have a simple packaged design.
- They are adaptable to variable speed drives.

The disadvantages of oil flooded rotary screws are that:

- They operate at somewhat lower efficiency than other types.
- They show only moderate durability, 10 to 15 years operating life on average.

Rotary Screw (Oil Free)

The advantages of oil free rotary screw compressors are that:

- They can maintain high air quality (0 PPM oil carryover).
- They operate at moderate efficiency.
- They have a packaged design.

The disadvantages of oil free rotary screw compressors are that:

- They have a higher initial cost.
- They have higher maintenance cost than other types.
- The maintenance requirements may not fall within the capabilities of on site maintenance personnel.
- (Consequently), they may require contract maintenance.

General Guidelines—Cooling

In general, users should consider the following cooling characteristics when considering specifying compressor designs:

- Fluid-air cooled designs are less expensive.
- Most designs have fluid or fluid-air cooled design options available.
- Closed evaporative cooling towers, open towers, and external fluid-to-air coolers are also viable cooling options.

Regulation/Controls Applications

Users should consider the following typical characteristics when considering (or specifying) system regulation or controls:

- Average number of compressors = 2.5 per facility.
- A typical system has manual controls.
- Each incremental 1 PSIG of unnecessary pressure cost 0.5 percent of compressor horsepower.
- Each electric motor driven compressor running unloaded = 35 to 50 percent of the full loaded electrical costs.

Regulation Basics

General considerations with regard to compressed air system regulation are:

- Do not run compressors unnecessarily.
- Evaluate current regulation parameters.
- Consider upgrading substandard controls.
- The most efficient operating point is 100 percent full load.

System Location and Arrangement

Outdoors

Some advantages of locating compressed air systems outdoors are that the system would:

- require zero floor space
- impose zero heat load.

Some disadvantages of locating compressed air systems outdoors are that the system might:

- be exposed to potential weather damage (freezing, water, etc.)
- potentially lack proper maintenance (i.e., the system would be “out of sight, out of mind”).

Indoors, Centralized

Some advantages of placing compressed air systems in an indoor, centralized location are that the system would:

- be protected from elements
- potentially be easier to access.

Some disadvantages of placing compressed air systems in an indoor, centralized location are that the system would:

- occupy the greatest floor space
- potentially require long piping runs.

Indoors, Decentralized

Some advantages of placing compressed air systems in an indoor, decentralized location are that:

- It would be possible to install the system closest to large air users.

- The system could be designed to allow the least amount of pressure drop through air lines.

Some disadvantages of placing compressed air systems in an indoor, decentralized location are that:

- Such a location yields the highest probability of incorrect regulation.
- The decentralized location carries the greatest potential to spread noise and heat, cause complaints to broadest number of employees.

Environmental Factors

Environmental factors to consider are:

- temperature
- ventilation
- conditions.

Temperature—Low

At temperatures below 35 °F, possible problems are:

- possible control freeze problem
- possible condensate freeze problem
- possible fluid misapplication.

Recommended solutions to low temperature-related problems are:

- install heaters
- install heat tracing key elements
- relocate the compressor.

Temperature—High

At temperatures above 100 °F, possible problems are:

- unit shutdown
- increased engine maintenance
- decreased lubricant life.

Recommended solutions to high temperature-related problems are:

- Improve ventilation/relocate.
- Use higher performance lubricant.
- Specify a more suitable equipment design.

Ventilation

Consequences of insufficient ventilation can be:

- possible unit shutdown
- increased maintenance
- possible decreased lubricant life.

To meet ventilation (cooling) requirements, the user must specify equipment that is either:

- air-cooled
- water-cooled.

Conditions

Surrounding air quality, noise level, ambient temperature, etc. are all primary concerns.

Basics for Compressor System Components

Design Criteria

The user must consider the following criteria before specifying an air compressor system:

- air quality required by user
 - moisture content
 - oil carryover
 - contaminants
- pressure drop
- demand characteristics
- energy profile.

Ideal Components for a Compressed Air System

An ideal compressed air system should contain the following elements (Figure 1):

- compressor
- aftercooler
- wet receiver
- pre-filter
- dryer
- after filter
- dry receiver

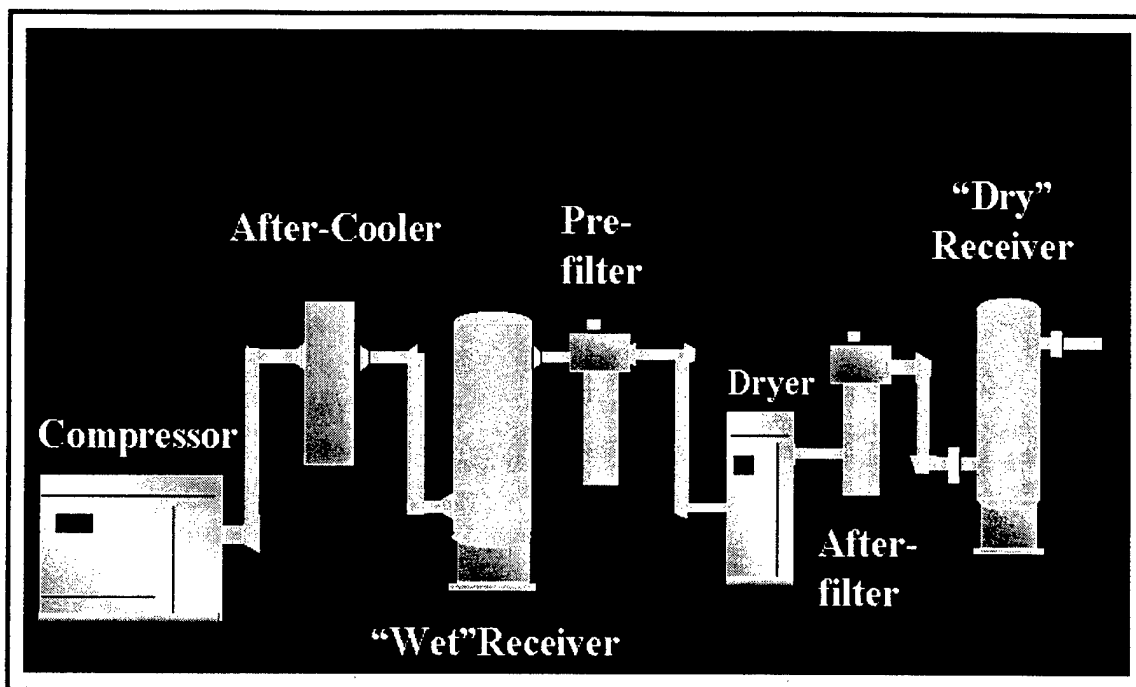

Figure 1. Ideal components layout.

The last two items in this list deserve explanation.

After Filter (Recommended)

The purpose of an after-filter is to reduce oil carryover. The benefit of this is derived from improved air quality, and improved product quality. One ready example of an application that would require this instrument would be a painting process.

Dry Receiver (Recommended)

The purpose of a dry receiver is to provide a reservoir of clean dry air to meet fluctuating system demands. The benefit of this item is that, when sized and installed correctly, a dry receiver can minimize airline pressure fluctuations. This also prevents short term capacity requirements from overloading cleanup equipment.

Moisture Content

The term "pressure dew point" refers to the temperature at which water vapor condenses into liquid in a compressed airline. A good "rule of thumb" is to select a dew point 10 to 20 °F below the lowest temperature the compressed airlines

will be subjected to. Note that this rule of thumb applies only to general industrial applications. Specific applications may have specific dew point requirements (i.e., paint booths, electronic instruments, etc.).

“Typical” Real World System

Description

A “typical real-world” compressed air system is assumed here to be a 1000 CFM system with:

- lowest plant ambient temperature of 60 °F
- sensitivity to lubricant
- fairly steady plant demand.

Pressure Drop

Users should bear in mind that:

- Pressure drop is the cost of air quality.
- Every air clean up device will use 2 to 10 psi to perform its function.
- Air dryers typically caused 3 to 5 psi pressure drop.
- Air filters typically resulted in 2 to 10 psi pressure drop (dependent on how long the element has been in place).
- Each pound of pressure drop equals to 0.5 percent total energy cost and additional filters may become needlessly expensive.

Demand Characteristics

In a typical system, receiver size and placement will vary depending on plant demand cycle and receiver size. Also, it is possible to supply a new intermittent large air user with a properly sized and installed receiver tank.

Oil Content Requirements

Whether the oil is removed at the compressor, or at the point of use, should be determined by overall plant requirements. Users should note that, although some equipment may benefit from (or even require) lubricant in compressed air, many other applications (paint booths, instrumentation) cannot tolerate it.

Typical Compressor Oil Carryover Values:**Reciprocating Compressors**

- Lubricated: 50 to 100 PPM
- Nonlubricated: 0 PPM

Rotary Compressors

- Oil Flooded: 3 to 10 PPM
- Oil Free: 0 PPM

Centrifugal Compressors

- 0 PPM

3 Compressor Types

Introduction

Compressors may be divided into two main types: positive displacement and dynamic compressor. Positive displacement compressors are the reciprocating, rotary screw, rotary sliding vane, liquid ring, and rotary blower. Dynamic compressors include centrifugal and axial types. The positive displacement compressor draws air into an enclosed space where it is compressed into a smaller space. A dynamic compressor draws air in and accelerates it to a higher velocity. The accelerated air then enters the compressed air system where it is slowed down. When the air velocity decreases, the pressure rises.

Positive Displacement Compressors

Reciprocating

A reciprocating air compressor functions much like a standard automobile engine (Figure 2). A piston is driven inside a cylinder by a crankshaft. As the piston is drawn towards the crankshaft, an intake valve opens in the cylinder head. The cylinder fills with air until the piston reaches the bottom of the cylinder. As the piston then begins to travel away from the crankshaft, the intake valve closes. As the piston is driven away from the crankshaft, the air inside the engine is compressed. When the compressed air reaches a high enough pressure, it opens an exhaust valve in the cylinder head and pushes compressed air into the compressed air system. A single acting reciprocating air compressor uses valves on only one end of the cylinder, compressing in only one direction. To increase efficiency, two cylinders may be operated with the same piston by placing an intake and exhaust valve at either end of the cylinder. With this arrangement, the piston compresses air in each direction. This is called a double acting reciprocating air compressor. The power to compress the air comes from an electric motor, an engine, or some other device that turns the crankshaft to drive the piston in the cylinder.

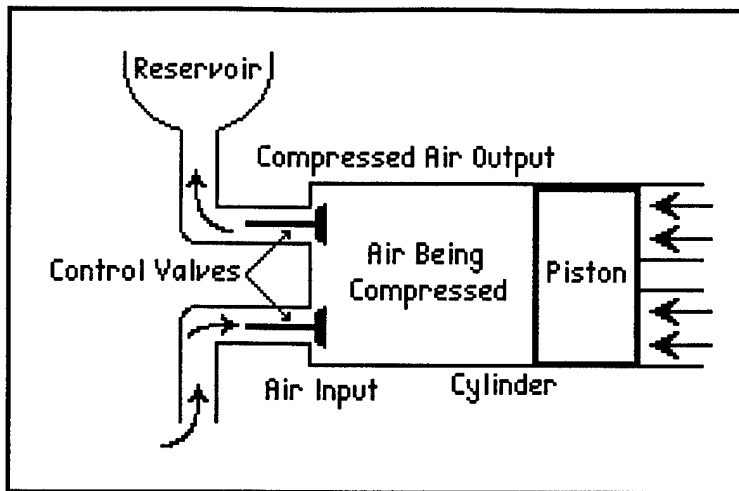

Figure 2. Reciprocating air compressors.

Rotary Screw

Rotary screw air compressors come in two drive configurations for the same basic design. The basic design is two rotors (one male and one female) meshed together and turning in opposite directions (Figure 3). One end of the rotors is exposed to the intake air, and the other is exposed to the compressed air system. The compression process begins with air filling the channels of the female rotor. The air fills the channels all the way around the rotor until the male rotor seals the channel. As the rotors turn, the air is driven into the compressed air system by the action of the male and female rotors pushing the air along the channel. One form of drive is with timing gears. The rotors are set within very close tolerance, and they do not touch. With this configuration, there is no need for oil within the system. Another form of drive is to have one rotor turn the other. This system requires oil to decrease wear and aid in cooling. Power is provided to the system by either driving the timing gear, or by driving the driven rotor.

Rotary Sliding Vane

Rotary vane air compressors are simple, self-lubricating, long-life units. The rotor is a cylindrical shaft with slots cut into it from the surface of the shaft towards the center of the rotor (Figure 4). Free-floating vanes rest in the slots, and are pushed out by centrifugal force. The vanes are pushed against the stator as the rotor turns creating a seal. The inner diameter of the stator is larger than the outer diameter of the rotor, and the rotor is offset within the stator. As the rotor turns, the vanes slide in as the air is compressed, and slide out as they draw in more air. The vanes are self-lubricating, and the oil on the surface of the stator leads to negligible wear of the vane tips.

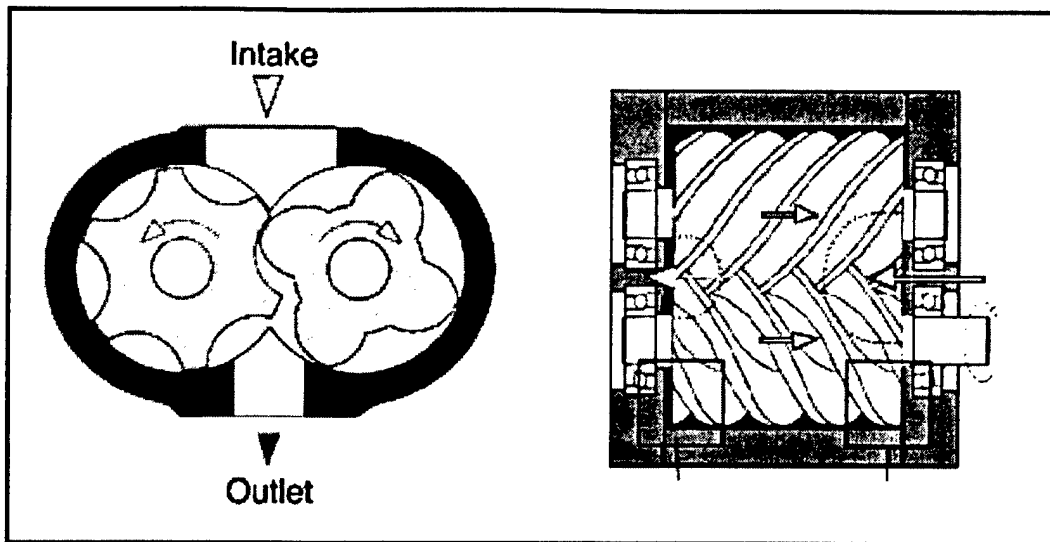

Figure 3. Rotary screw air compressors.

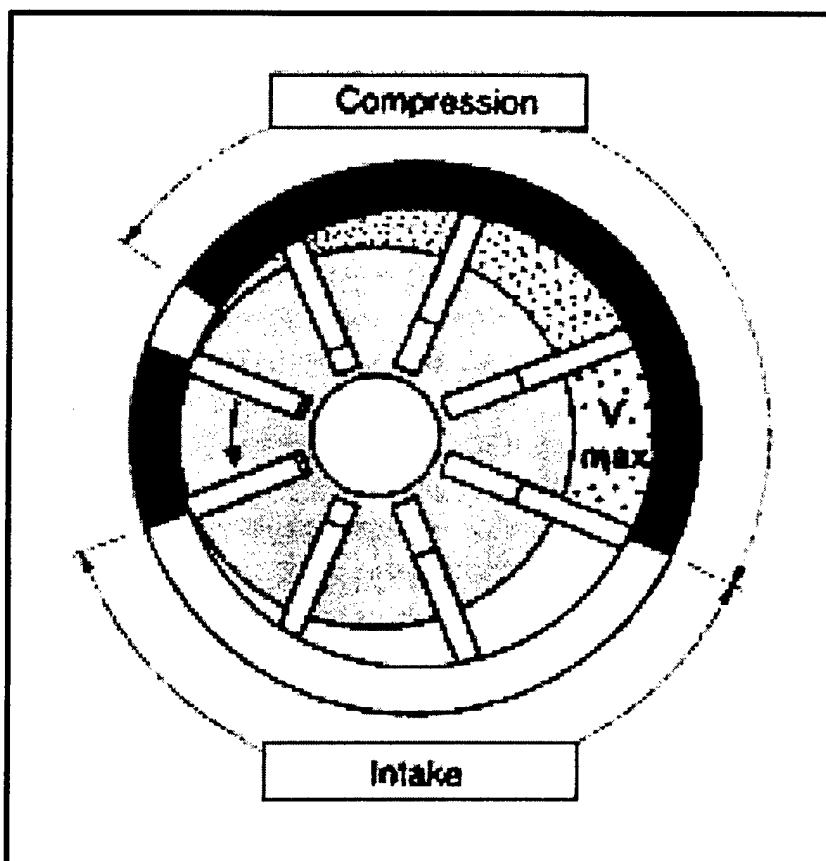

Figure 4. Rotary sliding vane.

Liquid Ring

The liquid ring compressor operates much as the sliding vane compressor. However, in the liquid ring compressor the vanes, do not touch the wall of the stator. Instead, liquid (usually water) fills much of the stator to create a seal. As the rotor turns, the water is thrown against the stator walls by centrifugal force. Air cannot escape past the vanes due to the water, and the air is compressed. The air is compressed as the rotor spins because the rotor is offset in the stator. This allows larger air volumes on one side of the rotor than the other with the liquid acting as a piston to compress the air. The intake and exhaust air ports are located in the shaft of the rotor. The water in this system fulfills two responsibilities. The first is to seal the compression chambers, and the second is to provide cooling for the compressor. Power is provided to this system by spinning the rotor much like the rotary vane. This is also the simplest system because the rotor is the only moving part.

Rotary Blower

The rotary blower is a low-pressure compressor that does not operate in exactly the same manner as the other positive displacement compressors. The other positive displacement compressors compress the air before it is pushed into the compressed air system. The rotary blower does not compress the air before it adds it to the system, but rather lets the added air do the compressing as it enters the system. The Rotary Blower operates much like the rotary screw. However, the rotary blower does not use the male and female screw assembly. Instead, there are two "figure-8" shaped rotors that turn in opposite directions (Figure 5). On one side of the rotors is the intake air, and on the other side is the compressed air. The rotors seal off a preset volume of air against the rotor housing, and push it through to the compressed air side. These systems rarely exceed 15 psig, and multiple blowers must be run in series to reach higher pressures.

Dynamic Compressors

Centrifugal

The centrifugal air compressor is a dynamic compressor that operates by imparting kinetic energy to the air. When the air enters the system, it is slowed down, and the kinetic energy is turned into pressure. A centrifugal air compressor acts by spinning a fan with an intake in the middle of the fan (Figure 6). As the fan spins, the air is thrown to the outside of the fan housing, and exits the compressor via the exhaust port.

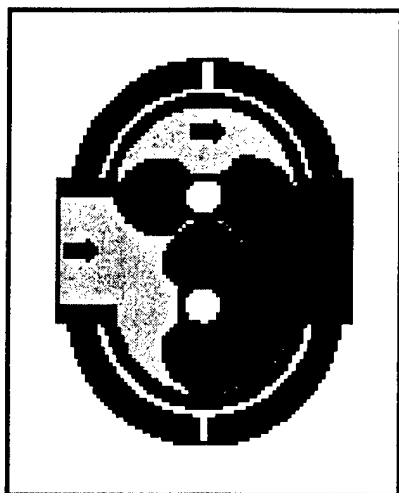

Figure 5. Rotary blower.

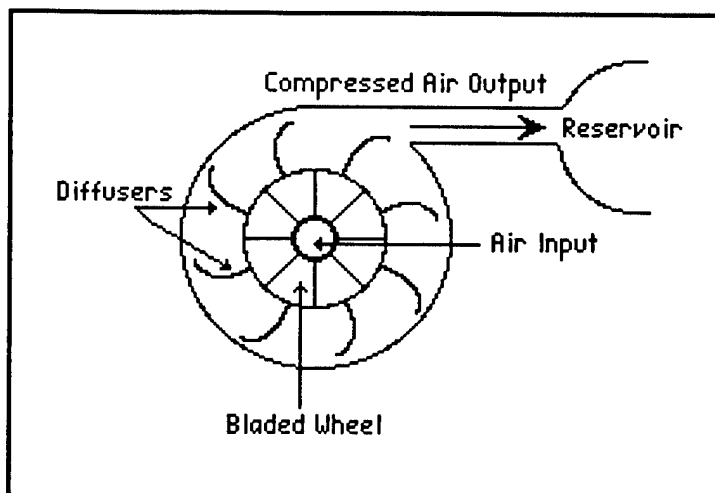

Figure 6. Centrifugal air compressor.

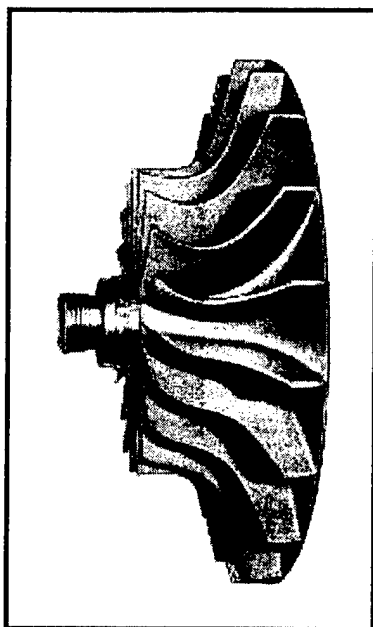

Figure 7. Centrifugal impeller.

Axial

The axial compressor is a dynamic compressor with a tapered turbine (Figure 7) that compresses the air through a series of rotating blades and stators. The rotating blades are affixed to a rotating shaft, and the stators are affixed to the tapered housing. As the shaft spins, the blades throw air into the turbine. As the air goes through the turbine, the stators slow it down to increase the pressure along with the taper.

4 Compressor Efficiency

Inherent differences between air compressor types affect their efficiencies. The difference may have to do with the set up of the machine, and/or the cycle used to compress the air. Following are simple considerations on compressor efficiencies.

Single vs. Multiple Stages

Multiple stage units are theoretically more efficient. They can cool down the air between stages reducing the work required to compress the air. However, single stage units are cheaper to buy.

Single- vs. Double-Acting Reciprocating Compressors

Single-acting reciprocating compressors are cheap and light. They are generally used in applications with smaller power requirements, and are usually air-cooled. Due to their small size, they do not require substantial base pad sizes. The downside of these compressors is their low efficiency.

Double-acting reciprocating compressors are the most efficient in the business. They are usually used in applications with higher power requirements, and are usually water-cooled. However, these compressors are quite heavy, and require substantial base pads. They are also more expensive to purchase than single-acting reciprocating compressors, and also cost more to install and maintain.

Rotary Positive Displacement Compressors

Rotary positive displacement compressors are smaller and quieter than reciprocating compressors. They also have smaller footprints than equal size reciprocating models, and may be installed directly on the factory floor. They also do not produce the pulsations typically found in reciprocating compressors due to continuous flow. Two-stage rotary compressors are more efficient than single-stage reciprocating, but not as efficient as two-stage, double-acting reciprocating

units, or three-stage centrifugal. Another drawback of rotary units is that their efficiency quickly decreases at part load.

Centrifugal Compressors

Centrifugal compressors are usually used in high load applications. As size (and number of stages) increases, so does efficiency. In fact, the efficiency of large centrifugal compressors can approach that of two-stage, double-acting reciprocating compressors. One major benefit of centrifugal compressors is their smaller size. Since they operate at high speeds, the internal parts do not need to be as large. This creates a smaller overall package. Centrifugal compressors are best used for constant load conditions where other compressors may pick up the excess.

Lubricant-Free Compressors

These compressors are less efficient than compressors that use lubricant. However, they may be more efficient in that no oil will enter the system from the compressor. They can also help meet environmental restrictions by reducing the amount of lubricant that is evaporated into the compressed air system. Centrifugal compressors are naturally oil-free.

Prime Movers

Electric motors are the most common prime movers for all types of air compressors. Federal requirements have been increasing the minimum efficiency requirements for these motors, and they now routinely have efficiencies between 85 and 95 percent. However, as the efficiency is increased, the starting torque is decreased. Also, the operating speed of the motor must increase. Other common prime movers are diesel engines and natural gas engines. The benefit of engine driven air compressors is their higher efficiency when throttled for part load applications.

5 Compressor Controls

Compressed air systems controls must efficiently provide sufficient compressed air to satisfy demands. In doing so, the controls must not over pressurize the system, and they must turn off unneeded compressors until they are required again. There are a variety of pressure controls that will provide this service: automatic start-stop, continuous run (step or modulating), throttled inlet, variable displacement, and variable speed.

Automatic Start-Stop

This is the most efficient manner of operating an air compressor. Air compressors are most efficient at full load, or off. The cycling of the compressor drive from full load to off will only consume energy in the most efficient manner until sufficient pressure has built up within the system. The drawback to start-stop operation is that many AC motors can only handle a certain amount of starts in a given timeframe before they will overheat.

Continuous Run—Step

This system uses two or more steps to vary the output of the compressor. The full open step is for 100 percent power. The full stop step is when the inlet is fully closed and the compressor is at idle. Any number of steps may exist in between, depending only on the complexity of the controller. The full open step and the idle step are the two most efficient levels for running operation of the compressor. This system's major drawback is that there must be adequate storage or the compressor will wear itself down with frequent starting and stopping.

Continuous Run—Modulating

Modulating the compressor to deliver the exact volume of air required delivers a stable air supply pressure, efficient operation, and quick response. The air supply is held at a relatively stable pressure due to the quick response of the modulating controller. The compressor runs more efficiently at higher demand pressures than other systems because it never has to provide greater pressure to the

system to “store up and turn off” as the other systems do. It merely provides the required air pressure, which is more efficient (increasing air pressure decreases efficiency). Since the controller has direct feedback from the system, it can quickly modulate output to air demand.

Throttled Inlet

In a “throttled inlet” system, when system pressure goes up due to a decrease in required air, a signal is sent to a valve in the compressor intake line to close. This throttles the intake air, decreasing the amount of compressed air entering the system. The advantage of such a system is that there is almost no cycling effect on any of the components. This decreases component wear and provides a constant system pressure. Also, the compressor does not have to “work extra hard” to build up supply so that it may shut off. This means that it does not have to run at higher than required pressures. This allows it to run at higher efficiency with less wear. This system is, however, less efficient at lower demand loads.

Variable Displacement

Variable displacement controls are primarily found in lubricated rotary screw compressors. Decreasing the effective length of the rotor compression volume makes the adjustment in airflow. The benefit from this system is that the inlet pressure remains the same since the decrease in airflow is controlled within the compressor. This means that the compressor does not have to work any harder to pull the air in, in addition to less work being required during compression because some of the air is left out of the process. The only drawback is that the venting options may add inherent inefficiencies that will show up at higher demand loads.

Variable Speed Drive

This is a very attractive control for varying load compressors. The power versus capacity curve shows that, from around 50 percent on up, the percent of max power drawn is close to an equal percent of max output. However, variable speed drives on electric motors require extra electrical hardware that will decrease efficiency of the motor. For these systems, natural gas engine-driven air compressor are more efficient than electrical motor driven air compressors due to greater energy efficiency of engines at lower output demands.

6 Compressed Air Dryers

Compressed air systems and tools operate much longer with properly dried air. Water in the lines washes away lubricant, fouls measuring devices, corrodes measuring devices, and fouls tools and equipment. The water comes from the air entering the compressor. Normal atmospheric air contains varying amounts of water vapor. When air is compressed, there is a temperature rise. This keeps the water vapor from condensing within the compressor. However, when the air goes through the aftercooler, condensation forms and must be removed. The air that leaves the aftercooler is now saturated with water vapor for the temperature at which it leaves. This water vapor must be removed before the air is used. The degree to which this air must be dried depends upon its ultimate use. The measure of the dryness is determined by the designed dew point of the air. The dew point is the temperature at which the vapor in the air condenses. Different driers are available to achieve these different dew points: Deliquescent, Desiccant, Internal Heat Reactivated, Heatless or Pressure Swing, Purge Control System, and Refrigerated air dryers.

Deliquescent Air Dryers

In a deliquescent air dryers, the compressed air is filtered through a chemical, which reacts with the water vapor in the air. The reaction (absorption) products are a liquid that may then be drained off. These dryers can suppress the dew point from 15 to 50 °F with appropriate bed level.

Desiccant Air Dryers

In desiccant air dryers, the compressed air is filtered through a chemical just as with the Deliquescent systems. However, the desiccant chemical does not react with the water vapor, but instead adsorbs it. Adsorption is a process of attracting and containing on the surface of the absorbing material. The material may then be removed and dried, or dried within the desiccant tower if supplied with heat, so the desiccant can be reused. To keep the desiccant dryer constantly operational, two towers may be employed. One tower may be used to dry the air while the other tower is being regenerated with heat.

Internal Heat Reactivated

Internal heat reactivated systems are used to regenerate desiccant air dryers. The upside is that the system handles drying itself with a controlled, internal heater. The downside is the purge air draws 2 to 3 percent of the rated flow, or an equal amount of alternate energy, to supply the purge air. Also, the system has a high initial cost, the heaters have a high repair cost, and the desiccant material has a short life, usually 1 to 2 years.

Heatless or Pressure Swing

Heatless or pressure swing systems are also used as desiccant air dryers. The heat of adsorption is used along with compressed air straight from the compressor to clean the water out of the desiccant material. The life of the desiccant in this system ranges from 3 to 5 years. The drawback with this system is the large amount of compressed air required (around 15 percent of rated flow). However, this system does not require internal electric heating, which reduces initial and repair costs.

Purge Control System

Purge controls are implemented to save energy on desiccant dryers. If the inlet conditions change from those assumed, then the desiccant will not be fully saturated when the automatic drying cycle begins. This wastes energy, and can be controlled. By measuring when the desiccant is saturated, the desiccant may be dried at optimal times. This decreases operating costs by not wasting purge air (internal heat and heatless systems) and outside heat (internal heat activated). The savings become even more noticeable with heatless systems where large amounts of purge air are used.

The two common methods are to skip the drying cycle and continue drying with the same tower, or to vary the purge flow. In the first instance, the dry cycle may be skipped until the tower is saturated. However, the limiting factor is the heat of adsorption process, which requires the dry cycle to start while there is adequate heat. In the second case, a varying purge control allows the tower to dry at the end of its cycle, but only the amount required (as automatically measured). The benefits of the varying cycle over the skip cycle are when the air demand suddenly increases to full load. The varying cycle will easily keep up, but the skip cycle will not catch up until the air demand decreases. This results in the desiccant becoming supersaturated until the drying cycle has a chance to

catch up. The benefit of the skip cycle over the varying cycle is the decrease in energy required and the low possibility of the supersaturated condition arising.

Other Desiccant Drying Systems

Several other methods may be used to dry desiccant materials:

1. An external blower may be used to force air over the desiccant. This will be more costly than using a heatless system, but the operational savings may justify the extra cost.
2. A small air stream may also be split from the operational tower supply. This air is then heated and fed through the drying tower. After this air leaves the drying tower, it is cooled to ambient temperature to release the purged water, and then fed back into the operating tower. This system loses no purge air, but does require extra cost to set up initially.
3. External heating of the dried compressed air reduces the amount of air required to clean the desiccant. However, the extra cost of heating and installation must be factored into the cost assessment.

The heat present in the compressed air after it exits the compressor may also be used to dry the towers. The air is vented from the compressor outlet before entering the aftercooler. This air is vented through the drying tower and then cooled to remove the moisture. The air is then mixed back with the air entering the operating tower.

Refrigerated Air Dryers

Refrigerated air dryers are typically used after a moisture separator and aftercooler. The air is then cooled within the air dryer, and the condensation is drained off. The outgoing air then helps cool the incoming air to decrease the load on the air dryer. The air is typically cooled below 40 °F, but above 32 °F to prevent freezing within the system. Cycling refrigerated dryers, as well as refrigerant bypass valves, may be used to respond to system demands.

7 Compressed Air Line Filters

Compressed air line filters are designed to remove oil, water, and solids that make their way into the compressed air system. The water and water vapor comes from the compression process. The solids that are present have either gotten past the compressor inlet filter, or have come from combustion of the compressor oils, as the cylinder temperatures in the compressor can be quite high. The oil can come in liquid or vapor form. The liquid form comes from condensation of oil vapors, as well as oil getting through the oil separator. The oil vapors come from vaporization of the lubricating oils under the high heat of the compression process.

Cyclonic Separators

Liquids may be removed from the CA system by mechanical impaction and centrifugal force. The filter is designed so that incoming air will begin to spin inside the separator chamber. The heavier droplets will impact the side of the chamber, and fall to the bottom. The air then passes through a screen where the remaining droplets are combed from the air. Another popular system is to run the air past baffles that knock the liquid out of suspension. The remaining air then passes through a screen to scrub away the rest of the liquid. Separators are best used before filters to reduce the demand and increase the life of the filter. Some manufacturers offer combination separator/filters that have both systems contained within one package. However, separators are unable to remove vapors; this requires a filter to be used after the separator.

Particulate Filtration

Particulate filters are used for dry contamination. They are placed in point of use locations (i.e., in front of instruments, downstream of desiccant and deliquescent dryers that contribute particulate matter, and even in front of expensive coalescing filters). These filters are rated for a certain size. The rating states that any particle equal to or above the stated size will be stopped with 100 percent certainty. This should be achieved with a high "dirt-load life," and a reasonably low-pressure drop.

Coalescing Filters

Coalescing filters combine aerosols into larger droplets within the filter. These droplets eventually achieve sufficient size to fall out of the filter into the bottom of the device for draining. An example of coalescing filters is glass fiber media. This material is neither absorbent, nor adsorbent. It will retain its dry properties throughout its useful life, which may be compromised by oils and particulate matter.

Absorption Filters

These filters actually absorb the liquids within their fibers. However, they do not perform well when saturated, and must be refreshed. The filter media may be composed of felt, cotton, wool, etc.

Adsorption Filters

Adsorption filters remove vapors from the compressed air. They do so by adsorption onto the surface of the filter media. A common media is activated carbon, which will remove oil vapor, but not water vapor. The only downside to activated carbon filters is that there is no way of determining the remaining life of the filter without accessing the air stream. The pressure drop will not change, so the air itself must be tested to determine the shape of the filter.

8 Automatic Condensate Traps

These traps eliminate the condensation that collects within the CA piping system, separators, aftercoolers, dryers, and receivers. This condensate must be drained to prevent its backing up into the compressor, or continuing throughout the piping system to the end use where filter, instrument, and tool damage may occur. The major operational issues regarding these systems are how to efficiently drain the condensate, and how to resist "gumming up" due to sludge buildup. When installed, these valves must be periodically checked to ensure correct operation. It is quite possible that a valve might stick open (which results in an audible and expensive problem), or stick close (which is silent, but a potentially disastrous problem). The most commonly used valves are: internal pilot actuated diaphragm, floating seal or guillotine, and electric motorized ball drain valves. Most electric valves used today have an electric timer that opens and closes them at specific intervals for designated amounts of time.

All these valves require regular maintenance and correctly set timers. Without regular maintenance, a valve can fail open or closed, and cause considerable damage or utility loss. Adjusting the electric timing for the operating conditions encountered is very important. If the valve does not exhaust all the condensate it receives, then the condensate may back up into the system and cause considerable damage. If the valve is exhausting too much air, then there will be a considerable increase in power consumption. Condensate valves are also available with automatic detection to drain the valve only when sufficient condensation has built up. Some valves are also designed so that there will be no excess air exhausted after the condensate has left the system. These valves eliminate the noise associated with such a process.

Internal Pilot-Actuated Diaphragm Valves

Internal pilot-actuated diaphragm valves (the cost of which ranges from about \$125 to \$200) are the simplest and cheapest types of valves used today. They have an internal valve that is operated by a solenoid. The valve opens to vent condensation. These valves are fairly resistant to fouling, but will still fail due to solenoid failure, faulty timer, bad diaphragm (valve), or because the vent hole has become plugged with accumulated, semi-solid residue ("gunk") from the system. A filter screen is recommended downstream.

Floating Seal Valves

Floating seal valves (the cost of which ranges from about \$175 to \$275) operate by sliding across the opening of a tube to open or close it. They are self-lapping and self-cleaning, but they usually have a much smaller orifice, which clogs more easily. These style valves require a strainer downstream.

Motorized Ball Drain Valves

Motorized ball drain valves (the cost of which ranges from about \$320 to \$450) use a ball valve that is operated by an electric motor. These valves are very resistant to fouling, and their common cause of failure is with the timing mechanism or electric motor.

9 Compressed Air Condensate Separators

Oil/Water separators can save condensate disposal fees as well as ensure legal compliance. Whether your compressed air system is operated by an oil free compressor or not, there is always a possibility of oil in the system. This oil, when separated from the air, must be drained off. However, if the oil is drained off with the water condensate, then the condensate must either be separated for proper disposal of the oil and the water, or the water must be disposed of at a much higher cost. Considering the large amount of condensate generated by a large CA system, the cost of disposing of many 50-gal drums of oil/water condensate can be quite high. If the oil is not separated, and the condensate is simply dumped, then environmental fines may soon accrue. However, if the oil is separated from the condensate, then the water may be dumped cheaply, and the waste oil may be handled separately in the (much lesser) quantity generated.

Gravity Separators with Carbon After Filters

These filters operate a skimming technique to remove the hydrocarbons from the water as it floats to the top of the chamber. However, this process will not remove any oil that is in suspension or solution, or that has a similar specific gravity to that of water. The removal of the remaining oils will depend on a carbon filter. The remaining condensate will be filtered through the activated carbon to satisfactory conditions. The only disadvantage of the carbon filter is that it cannot be tested for remaining life. Instead, the effluent will have to be tested for conformance to determine the state of the filter. The activated carbon also has to be replaced when used up, which will result in another disposal fee.

Gravity Pre-Separation with Coalescing Filters and "Carbon After Filters"

Coalescing filters and "carbon after filters" operate in much the same manner as gravity separators, except that they use a coalescing filter before the activated carbon filter. This removes the larger particles from the condensate leaving just the smaller particles for the activated carbon filter to manage. These type filters manage unstable oil suspension and emulsion very well, but need excessive carbon filtering to deal with stable emulsions or suspensions.

Membrane Separation (Ultrafiltration)

This is an additional filter to be used with the above-mentioned systems. This filter will remove everything but stable emulsions and polyglycols.

Membrane Separation (Nanofiltration)

This type of filter is used after a gravity system with surge dissipation, a circulation pump, and coalescing filtration. This manner of filtration will meet or exceed all requirements presently in place throughout the United States. The downside of these filtering devices is their relatively short life and the sensitivity of the units.

Distillation Type

These separators do not require filters of any kind. The condensate is heated to drive the water to a vapor state (this is done at a temperature lower than the significant vapor points of the oils in the condensate). The water is then vented off to the atmosphere, and the remaining solution is disposed of.

10 Compressed Air Distribution System

In general, distribution systems fall into two categories: centralized and departmentalized. Many systems are composed of variations and/or combinations of the two types. Within these main systems, certain components should be used to ensure that the CA system operates efficiently and safely.

Centralized

All air compressors are located in a room or building with all air treatment equipment. This allows the use of larger (more efficient) equipment, and limits the need to route electricity and water to one location. The larger, more efficient compressors that may be used usually require less maintenance. This feature along with placement of all CA equipment in the same location help to decrease maintenance costs. The central location also makes heat reclamation in these systems easier and more efficient. Instead of retrieving heat from various CA heat sources scattered throughout the complex, the heat may be pulled from one central location with fewer and larger equipment used to recover the heat. Larger equipment usually offers higher efficiencies, so the net heat recovered will be higher. Since the equipment is installed in one area, total installation costs are reduced.

The downsides of this system result from the CA being produced in mass at one location and one specified outlet condition. Such a system will require a larger and more expensive piping system to accommodate the greater volume of compressed air coming from one location. Friction within the extensive piping system will also cause losses that will require the central system to run at higher load for the required output. This means that, if the CA demand increases, the pipes will have to be replaced with larger pipes to accommodate the higher demand without increasing pressure loss. This radical solution is not a commonly taken; it is more likely that the same pipes will be used and the efficiency of the system will decrease. The end result of this practice will be strain on the central system. Another area of trouble is with part load requirements. Where a departmental system can be turned on and off, a central system will have to run at a part load condition for large air uses such as sandblasting. This will require the central system to run at low efficiency to supply the low demand. Finally, if a higher CA demand is called for, another compressor will have to be added in

line to meet the requirement instead of raising the pressure of the main station, which will be very inefficient.

Departmental

Departmental systems use multiple compressors where and when they are needed. Hence, certain compressors may be shut off when they are not needed, and varying air pressures may be supplied on demand with decreases in efficiency at only the specified areas. In addition to varying air pressures on demand, air quality may be varied from department to department. Without the need for continuous piping throughout the complex, the piping will not have to be as large. This will also decrease the pressure losses associated with long pipe runs. With the systems in the locations for which they are designed, high efficiency will result from the ability to run full on with demand, or full off when not required. If any department cannot handle its peak load requirement, then another department can be patched in to aid in peak demand. Finally, plant expansion will be easy to accommodate with additions to the system.

Suction Pipe

Intake pipes for air compressors should never be smaller than the intake for the compressor. Long runs should be avoided, and larger diameter piping should be used just before the compressor intake. The large diameter piping will dampen intake pulsations as well as act as a trap for condensate in the intake air.

Pipe Strain

All piping should be supported so that the compressor will not experience life-shortening strain. Also, the aftercooler should be mounted as close to the exit of the compressor as possible. This will decrease the pipe strain associated with thermal expansion of the pipes. However, by-pass piping should be provided so that the aftercooler may be isolated and worked on without shutting down the CA system.

Air Receiver

The air receiver serves a number of purposes other than merely to store air. The air exiting the compressor can set up pulsations that can damage the CA system.

The air receiver serves to reduce the severity of these pulsations by slowing down the air as it enters. This action itself also aids in drying the air. As the air is slowed down, condensation forms. This condensation can then be removed decreasing the work required by the dryer downstream. For large, reciprocating compressors, another pulsation controller should be added after the receiver unit.

Drip/Drop Legs

Drip legs are merely extension of the piping system that catch any moisture that condenses inside the pipe. They are especially useful for pipes that experience lower temperatures than the dryers are designed for. The drip leg should come off the piping system at the lowest local point. It should also be outfitted with a blow-down valve at the bottom of the pipe. The drip leg should attach to the main piping system at the bottom of the pipe. All piping in the CA system should slope 1 in. for every 10 ft along the direction the air flows. This will aid in the collection of condensation by the drip pipes. Drop legs supply air to locations directly below a major CA pipe. They should come off the top of the main pipe so that minimal condensation will enter the drop pipe, and the outlet valve should be located on the side of the drop pipe so that any condensation that does make it into the drop pipe will be contained below the outlet valve. A blow-down valve should also be installed at the bottom of the drop pipe.

Pressure Drop

Pressure drop in a CA system can add substantially to the utility costs. As the pressure drops in a CA system, the inlet pressure must be increased to deliver the required pressure downstream. However, increasing pressure 2 psig can increase power consumption 1 percent. This means that decreasing the pressure drop within your CA system can save significantly on utility costs. Methods to decrease pressure drop include: increasing the diameter of the CA piping; decreasing the friction coefficient of the pipe; decreasing the number of bends, valves, couplings, and other fittings; and decreasing the length of the piping. The increased piping diameter reduces the velocity of the flow, the decreased frictional coefficient and decreased number of fittings decrease the friction encountered by the flow, and decreasing the length decreases the frictional surface area encountered by the flow. Careful design and control of the CA system can reduce pressure drop dramatically. This will save in utility costs.

The most efficient pipe setup is to run a loop system that will send compressed air in either direction to the operational tool. The addition of receivers throughout the system (positioned in areas of sporadic, heavy demand) will also help reduce pipe friction by effectively supplying air closer to the location of demand. This decreases the distance the air must travel in large volumes at high-pressure drops. Also, the air driven into the receiver is driven by a smaller pressure drop (from compressor pressure to receiver pressure which is essentially the same). This will result in a lower ultimate velocity of the make-up air, thus decreasing the energy wasted on overcoming friction.

11 Determining Compressed Air Requirements

Many considerations should be taken into account when deciding upon the system best suited for the user's applications. Anticipated future growth, magnitude of constant demand and surge demand (and frequency and duration of surges), repair and maintenance, and air quality.

To better understand how to determine CA requirements, it helps to understand how to calculate the demand placed on the compressed air system in relation to the system's capacity. If you start with a 100 cu ft tank of air at 0 psi, then add 100 cu ft of air at atmospheric pressure, the pressure in the tank will increase by 14.7 psi. This can be used to determine the amount of air consumed by your CA system, as well as the amount of air supplied by your compressor. If you cut off the supply to your system, then measure the amount of time it takes to drop the pressure from one measured point to another, you can determine the draw of the system using the equation:

$$\text{capacity} = (\text{volume of receiver}) \times (\text{change in pressure}) / 14.7 / (\text{time in minutes}) \quad \text{Eq 4}$$

This can also be used to determine the supply from the compressor if the system is shut off from the receiver. The safety factors you should be looking for are: 20 percent of supply goes to leaks and overcapacity, 30 percent oversize for water-cooled compressors and 40 percent oversize for air-cooled. If the supply does not retain these safety factors, then the compressor may be overloaded.

Anticipating Future Requirements

Future requirements should be considered when designing or retrofitting a CA system. First, evaluate expected pressure losses from added hose, pipe, in-line filtering, and regulators/disconnects. Then, anticipate load requirements for future tool and machine addition from manufacturer specifications as well as air cleaning capacity and receiver capacity requirements. Finally, examine the current system to see if it may be designed to run economically with these future requirements already implemented (to save retrofitting costs down the road).

CA Receiver

Size and placement of receivers should be taken into account. If future additions are already known, then design current system receivers to handle the additions. Also, a receiver cannot be too large, so size for present plus future demands if possible. To size the receiver, use the equation:

$$V_r = (V_s \times 14.7) / \Delta P \quad \text{Eq 5}$$

where:

V_r = receiver volume, cu ft

V_s = usable stored free air vol, cu ft

ΔP = pressure drop in receiver, psig.

12 Compressed Air System Audit

An audit is a powerful tool that can help reduce energy consumption, increase productivity, decrease labor, and decrease waste. Periodic audits should be performed to evaluate the current operating conditions of compressed air systems. The more often changes are done to the system, or the more often design changes occur throughout your facility, the more often there will be the chance for inefficiency to increase. An auditor will be able to locate and reduce these inefficient operations, and will bring alternate ideas that might not be immediately apparent to the user. Bear in mind that even small plant changes can have significant effects on CA system efficiency. Keeping abreast of the changes in the plant, and monitoring air use can help uncover inefficiencies before they become expensive. Also, alternate methods and other improvements will become more noticeable. A CA system audit can help determine the actual cost of compressed air, and even identify some opportunities to decrease waste/improve efficiency. Outside, independent companies may be hired to perform an audit, but care should be taken that they are not promoting any particular brand. Some utility companies may even help fund an audit.

An audit should examine air production and air use. It should also investigate the manner in which it goes from supply to each end use. The cost side of an audit should measure the output of the system, and calculate the energy consumed and annual cost. The final point of investigation is air leaks. All components of a CA system should be investigated for significant air leaks, and each leak should be labeled. The final report should then outline all leaks, inappropriate uses, demand events, poor design, and system dynamics with a recommended course of action.

The auditor should also address system issues. System issues involve the entire system, not just individual parts. The issues most often addressed are:

- level of air treatment (and efficiency)
- leaks
- pressure levels
- controls
- heat recovery.

On the demand side, issues most often addressed are:

- distribution system
- load profile
- end-use equipment.

On the supply side, issues most often addressed are:

- compressor package
- filters
- aftercoolers
- dryers
- automatic drains
- air receivers
- storage.

On the supply side, the efficiency of the receiver package as well as the individual components of air treatment should be examined for efficiency, expected life, type, and application.

Level of Air Treatment

The auditor should examine the current system and the end-uses of the air. The air should then be tested and it should be determined whether or not the level of treatment is correct. If it is not high enough, then corrective actions should be taken. If the level of air is too high, then actions should again be taken if a savings in operational costs is evident. However, if there are multiple levels required, then consideration as to the appropriate output and subsequent treatments before the end-use should be recommended.

Leaks

The auditor should identify all leaks in the system and identify the magnitude of the leaks. The auditor should also recommend a management schedule to deal with leak prevention.

Pressure Levels

The auditor should also specify a minimum pressure level for the system. The pressure level should consider the minimum pressure allowable per critical ap-

plications within the system. However, if dedicated storage or differential reduction are a possibility for a high pressure application, then they should be noted and investigated for possible overall system pressure reduction.

Controls

The auditor should examine the load profile of the system. Systems with widely differing load profiles benefit most from more sophisticated controls. The auditor should evaluate the existing controls to determine if an upgrade would be beneficial. Air receivers should also be considered for controls modifications. However, correct placement in the system is crucial, and may require other modifications.

Heat Recovery

The auditor should identify uses for recovered heat if there are no current systems for heat use.

Distribution System

The auditor should examine the condensate removal, pressure drop, and efficiency of the piping system. Recommendations may be made on simple changes that will have noticeable benefits.

Load Profile

The auditor should measure system flow over a period of time (usually 24 hours), and take into consideration changes in demand over the course of the year.

End-Use Equipment

All equipment and processes that use compressed air will be evaluated. In some cases, equipment that uses lower air pressure will be recommended. Also, local storage and critical air applications will be examined. The auditor will not necessarily recommend compressed air improvements, because there may be alternate energy source tools that could fulfill the requirements (i.e., electric drills).

Compressor Package

The compressor will be evaluated on its operating condition and the suitability for its application. The site will be evaluated on its access to cooling water, fresh air, ventilation, etc. These factors along with estimated compressor efficiency will be used for alternate system recommendations (if any). The auditor should also give a general appraisal of the compressor.

Filters

The current filters will be examined for suitability and pressure drop. Higher performance filters may be recommended, and a maintenance schedule should be developed for the filters.

Aftercooler

The effectiveness of the entire cooling system (cooling, condensate separation, separator efficiency, etc.) will be measured and evaluated. Alternatives and modifications will be recommended.

Dryer

The auditor will evaluate the dryer according to end-use applications. In addition, the pressure drop, efficiency, and sizing should be measured and evaluated. The auditor should make recommendations for modifications and replacement if necessary.

Automatic Drains

Demand and supply side drains should be examined for location, application and effectiveness. Alternatives should be recommended if necessary,

Expansion/Economy

What opportunities exist for expansion? How easy will it be to expand, and what will the efficiency of the expanded system be? If the demand for compressed air decreases, are there ways to economize the system?

Air Receiver/Storage

The effectiveness of the receiver tanks will be evaluated. Location and size should be considered, as well as pipe layout. The drain trap should also be evaluated to determine whether or not it is operating correctly. Other storage solutions (or modifications or additions to the current system) should be investigated, and recommendations should be made if necessary.

More Comprehensive Evaluations

If a system is found to be operating far off optimum values (i.e., efficiency, size, reliability, etc.), then a more comprehensive audit should be done. This audit should include measurements and analysis of the entire system including changes due to varying demand. A financial evaluation may also be performed to compare the present system to a recommended one.

13 Compressed Air System Optimization

The goal of system optimization is to achieve the lowest possible level of overall cost per unit of product. System optimization comes from a variety of tasks: supply management, waste management, demand side management, design, heat recovery, and audits.

Design

First and foremost is the design of the system. The system must be designed with the lowest pressure drop possible. (The pressure drop should be less than 10 percent from compressor to end-use.) This will allow a lower pressure to be run throughout the system, which will decrease energy consumption. However, care must be taken that pressure will not drop below minimum during periods of high demand. In these cases, adequate air storage must be used. The system must also be designed by compressor capacity, and not by compressor hp. When designing the system, care should be taken to reduce the distance the air must travel to its end-uses. The less distance air has to travel, the less energy loss due to pipe friction. When the air actually arrives at the point-of-use, the air must be able to exit freely to the tool. One major cause of leaks is poorly specified equipment. It is usually worthwhile to spend the extra money on an efficient component with higher efficiency than on a cheap component that will consume larger amounts of energy. This can be found in the supply side as improperly specified filters (consider dirt load and standard P-drop), cheap regulators, separators, and dryers, and on the demand side with high quality hoses, regulators, and disconnects. Because all of these components will contribute to energy consumption throughout the life of the system, higher efficiency items will more than likely pay off. The final point of the system design is the actual construction of the piping. The proper distribution design should be installed depending upon the intended use of the compressed air.

Supply Management

Managing the compressed air at the source is crucial to increase efficiency. Many facilities operate their compressed air systems higher than the minimal, optimum pressure. If the system is operating at 100 psi, but the use require-

ments are only 80 psi, then substantial savings will result from lowering output pressure. If any certain process in the plant requires higher than standard air, then a higher-pressure compressor or a booster compressor may be in order. Component maintenance is also necessary to keep the pressure drop across filters and separators as low as possible, as well as to decrease corrosion due to water. The final point of the supply side is the air quality. If the quality of the air being produced is higher than necessary, then too much energy is being expended on cleaning the air. Measures should be taken to ensure minimum air quality, but not more.

Demand Side Management

Demand side management relies on design as stated above, but also requires maintenance and periodic checks. The maintenance should cover all regulators, connectors, and hoses. If any of these components leaks, then they should be repaired as quickly as possible. Also, if any of the hoses, connectors, or regulators are damaged or restricted in any way, then measures should be taken to restore them to proper operating capacity. Finally, the regulators should be checked to ensure that they are placed at the proper settings. Many operators set the regulators at higher pressures than necessary. This results in tools drawing compressed air at inefficient rates in comparison to the work being done.

Waste Management

Waste management mainly involves leak management and air conservation on the compressed air side. To this end, production managers and operators should be in contact with maintenance personnel to report air leaks and other system troubles. To aid in air conservation, inappropriate uses should be avoided. Inappropriate uses may range from using the wrong energy source to unregulated end-use to abandoned equipment. An example of inappropriate end-use is using an air-powered drill for an application where an electric drill would fulfill the same function with higher efficiency. Unregulated end-use was mentioned above in demand side management, but should be monitored by a waste management team. Abandoned equipment provides the possibility for massive compressed air loss. Whenever possible, abandoned equipment should be removed from the compressed air line as far back into the system as is possible. To give an idea, a typical system without any leak management program can lose 20 to 30 percent of its compressed air to leaks. With an effective leak management team, this value can be reduced to 10 percent. Leaks do more than just tax the compressor. A leak can decrease the pressure at the point of use so that the tool in question

does not receive the pressure it requires. This will decrease the efficiency of the tool, and compound the loss in efficiency.

Heat Recovery

Fully 80 to 90 percent of the energy consumed by an air compressor is turned into heat. This is the primary reason for the low "wire-to-work" ratio for compressed air. However, all this energy does not have to go into compressed air flow to be used. The heat can be used for other processes at up to 90 percent recovery rates. These processes can range from heating and industrial processes to make up air and boiler make-up water heating. In general you can expect 50,000 Btu/hour from 100 cfm of capacity at full load. This will decrease the energy consumed throughout the rest of the plant so that savings are evident even though the energy consumption of the air compressor has not decreased.

References

A wide range of information is available on the application and use of compressed air systems. Information presented here was compiled in the following categories:

- books and reports
- brochures
- periodicals
- software
- videos workshops and training courses
- glossary of terminology.

The resources and tools presented here are not intended to represent all available information pertaining to compressed air systems. This list presents the reference material and tools specifically of interest to those involved in energy-efficient compressed air systems. Availability of this information does not imply any endorsement for any product or information.

Books and Reports

The books and reports listed are grouped into one of the following three categories:

1. Documents on compressed air systems focusing on performance improvement
2. Specialty books on compressors (e.g., compressor design)
3. Information on the compressed air market

Documents Focusing on Performance Improvement

Air Compressors and the Compressed Air System

Author: William Scales, P.E.

Description: A comprehensive text on maintaining compressed air systems for peak performance.

Available from:

Scales Air Compressor Corporation
110 Voice Road
Carle Place, NY 11514
Phone: (516) 248-9096
Fax: (516) 248-9639

Assessing Processes For Compressed Air Efficiency

Authors: Bill Howe, P.E. and William Scales, P.E.

Description: The report presents 11 questions managers should answer about their compressed air applications to determine whether compressed air is the right tool for the job, how compressed air is applied, how it is delivered and controlled, and how the compressed air system is managed.

Available from:

E SOURCE Reprints Service
1033 Walnut Street
Boulder, CO 80302-5114
Phone: (303) 440-8500
Fax: (303) 440-8502

Compressed Air and Gas Handbook, Fifth Edition

Author: Various Compressed Air and Gas Institute members with John P. Rollins, ed.

Description: A comprehensive reference work on all phases of compressed air and gas, this handbook covers reciprocating, rotary, and dynamic compressors; pneumatic tools; construction equipment pneumatic controls; materials handling equipment; and many other topics. The sixth edition will be published in 1998.

Available from:

Prentice-Hall Publishers
200 Old Tappan Road
Old Tappan, NJ 07675
Phone: (800) 223-1360
Fax: (800) 445-6991

Compressed Air Management, Energy Efficiency in Compressed Air Systems Seminar Workbook

Author: T.F. Taranto

Description: Used in seminars, this work book is a resource for the industrial compressed air user. Topics include concepts of compressed air system management, compressed air system investment, cost of compressed air, system performance modeling, benchmarking system performance with data measurement, and system management strategies.

Available from:

Data Power, Inc.
P.O. Box 182
Baldwinsville, NY 13027
Phone: (315) 635-1445
FAX: (315) 635-1445

Compressed Air Systems

Author: HP. Van Ormer

Description: This handbook discusses compressed air systems including departmental and central air systems. It covers topics such as compressor types; application, selection, and installation of rotary and centrifugal air compressors; compressor capacity controls; compressor terminology; determination of air requirements; compressed air dryers; and optimization of systems.

Available from:

Air Power USA, Inc.
P.O. Box 292
Pickerington, OH 43147
Phone: (614) 862-4112
Fax: (614) 862-4112

Compressed Air Systems Solution Series

Author: Scot Foss

Description: This comprehensive text discusses ways to improve the performance of compressed air systems. It is published as a 2-year, bi-monthly subscription series. It covers topics such as design issues, troubleshooting, instrumentation, storage, piping, controls, demand issues, and supply issues.

Available from:

Bantra Publishing
Phone: (704) 372-3400

Compressed Air Systems: A Guidebook on Energy and Cost Savings

Author: E.M. Talbott

Description: This guidebook covers topics ranging from compressed air equipment and distribution system layout to final application and system operation.

Available from:

Prentice-Hall Publishers
Englewood Cliffs, NJ
Phone: (800) 223-1360
Fax: (800) 445-6991

Compressed Air Technology Seminar Workbook: Opportunities and Solutions

Author: HP. Van Ormer

Description: Used in Mr. Van Ormer's compressed air seminars, this workbook serves as a good resource for those looking to improve the efficiency of their compressed air systems. Topics discussed include compressed air basics, supply equipment, regulation and controls, system design, receiver demand flow regulation, maintenance and reliability, power savings, leak surveys, and flow meters.

Available from:

Air Power USA, Inc.
P.O. Box 292
Pickerington, OH 43147
Phone: (614) 862-4112
Fax: (614) 862-4112

Compressor Engineering Data

Author: William Scales, P.E.

Description: A handbook of reference material on compressed air systems.

Available from:

Scales Air Compressor Corporation
110 Voice Road
Carle Place, NY 11514
Phone: (516) 248-9096
Fax: (516) 248-9639

Compressors and Expanders: Selection and Application for the Process Industry

Author: Heinz P. Bloch

Description: This book identifies preferred equipment types for specific uses, provides easy-to-understand explanations and examples, examines the limitations of the machinery, and compiles data that is scattered throughout the literature. The potential audience includes engineers interested in gas separation, cryogenic processes, and compression stations; manufacturers and purchasers of compressors and turboexpanders; and contractors involved in plant design and machinery selection.

Available from:

Marcel Dekker, Inc.
270 Madison Ave.
New York, NY 10016
Phone: (212) 696-9000
Fax: (212) 685-4540

Compressors: Selection and Sizing, 2d ed.

Author: Royce N. Brown

Description: This reference text provides information on compression principles, equipment, applications, selection, sizing, installation, and maintenance; allowing proper estimation of compressor capabilities and selection of designs. Updated with new American Petroleum Institute standards and current technology in areas of efficiency, 3-D geometry, electronics, and plant computer use, this guide covers reciprocating, rotary, and centrifugal compressors and compares their reliability.

Available from:

Gulf Publishing Company
P.O. Box 2608
Houston, TX 07675
Phone: (713) 520-4444
Fax: (713) 520-4433

Pumps/Compressors/Fans: Pocket Handbook

Authors: Nicholas P. Cheremisinoff, Paul N. Cheremisinoff

Description: This handbook provides a concise presentation of the fundamentals—design, function, and applications—of pumps, compressors, and fans. It is organized for easy reference and illustrated with more than 80 photographs, diagrams, and other schematics. This text will help engineers and other plant operations personnel in their selection and utilization of pump, fan, and compressor equipment.

Available from:

Technomic Publishing Company, Inc.
851 New Holland Ave.
Box 3535
Lancaster, PA 17604
Phone: (800) 233-9936
Fax: (717) 295-4538

Specialty Books

Centrifugal Compressor Design and Performance

Author: David Japikse

Description: This publication is both a state-of-the-art review of the technology base of centrifugal compressors and a practical guide to designers.

Available from:

Concepts ETI, Inc.
4 Billings Farm Road
White River Junction, VT 05001
Phone: (802) 296-2321
Fax: (802) 296-2325

Compressor Performance: Selection, Operation, and Testing of Axial and Centrifugal Compressors

Author: M. Theodore Gresh

Description: This book is divided into two main sections. In the theory section of the book, the Author introduces aerodynamics, thermodynamics, aerodynamic components, and compressor characteristics. In the application section, the Author discusses equipment selection, operation, field performance testing, troubleshooting, and flow meters.

Available from:

Butterworth Heinemann
225 Wildwood Ave.
Woburn, MA 01801
Phone: (617) 928-2500 or (800) 366-2665
Fax: (617) 933-6333

Control of Centrifugal Compressors

Author: Ralph L. Moore

Description: This text provides comprehensive information on the techniques for controlling centrifugal compressors. In addition to compressor control issues, optimization of compressor operation and multiple compressor systems are topics also discussed.

Available from:

Instrument Society of America
67 Alexander Drive
P.O. Box 12277
Research Triangle Park, NC 27709
Phone: (919) 549-8411
Fax: (919) 549-8288

Fluid Movers, 2d ed.

Authors: Nicholas P. Chopey and Chemical Engineering Magazine Editors

Description: This text is a compilation of current articles on the movement of fluids with pumps, compressors, fans, and blowers from Chemical Engineering Magazine.

Available from:

McGraw-Hill
P. O. Box 546
Blacklick, OH 43004-0546
Phone: (800) 722-4726
Fax: (614) 755-5654

Leak-free Pumps and Compressors, 1st ed.

Author: Gerhard Vetter

Description: As environmental regulations concerning leaks and emissions become more stringent, this practical reference manual targets those concerned with systems using leak-free pumps or compressors. This handbook explains the various designs and properties of leak-free pumps and helps in the selection of the right pump or compressor to ensure leak-free systems, whatever the application.

Available from:

Elsevier Advanced Technology
Mayfield House
256 Banbury Road
Oxford OX2 7DH England
Phone: 01865-512242
Fax: 01865-310981

Optimization of Unit Operations: Boilers, Chemical Reactors, Chillers, Clean Rooms, Compressors, Condensers, Heat Exchangers, HVAC Systems, Pumping Stations, Reboilers, and Vaporizers

Author: Bela G. Liptak

Description: This text examines the technical and practical applications of plant multivariable development control. Optimization of various systems is discussed in detail.

Available from:

Krawse Publications
700 E. State St.
Iola, WI 54990
Phone: (888) 457-2873
Fax: (715) 445-4087

Reciprocating Compressors: Operation and Maintenance

Authors: Heinz P. Bloch and John J. Hoefner

Description: This book discusses the theory of operation and describes methods of proper installation, troubleshooting, overhauling, and repairing of all types of reciprocating compressors. Engineers and maintenance personnel in the process industries such as mining, food processing, pharmaceuticals, and petrochemicals will find this text useful.

Available from:

Gulf Publishing Company
P.O. Box 2608
Houston, TX 77252-2608
Phone: (713) 520-4444
Fax: (713) 520-4433

Rotary Screw Air Compressors

Author: H. P. Van Ormer

Description: This guide provides a close look at the lubricant-cooled rotary compressor and its role in construction and industrial applications. It discusses the history, development, basic technology, application, selection, installation, and general maintenance of rotary screw air compressors.

Available from:

Air Power USA, Inc.
P.O. Box 292
Pickerington, OH 43147
Phone: (614) 862-4112
Fax: (614) 862-4112

Information on the Compressor Marketplace

Compressors—Air & Gas Wholesale

Description: This annual directory features information on 4180 wholesalers of air and gas compressors.

Available from:

American Business Information, Inc.
5711 South 86th Circle
P.O. Box 27347
Omaha, NE 68127-0347
Phone: (402) 593-4500
Fax: (402) 331-5481

Compressors, Vacuum Pumps, and Industrial Spraying Equipment

Author: Specialists in Business Information, Inc.

Description: The U.S. market for air and gas compressors, vacuum pumps, and industrial spraying equipment strengthened in 1995 and 1996. Specialists in Business Information (SBI) has compiled and analyzed data on U.S. factory shipments, imports, exports, industry costs structure, and the competitive environment to uncover strategies that will allow manufacturers and marketers to penetrate growing markets in this \$4-billion industry. SBI has also profiled worldwide manufacturers and reviewed their recent developments as part of an exhaustive effort to provide competitor intelligence. In addition, SBI has extracted sales and profit trends for 16 manufacturers in order to compare company performance with industry averages. Some of the major producers profiled include Dresser-Rand, Gardner Denver, Nordson, and Sunstrand.

Available from:

Specialists in Business Information, Inc.
3375 Park Ave.
Wantagh, NY 11793

Pumps and Compressors

Author: U.S. Department of Commerce, Bureau of the Census

Description: This annual Current Industrial Report provides statistics on the quantity and value of manufacturers' shipments, number of producers by product type and industry, exports, and imports. These statistics reflect market trends in the pump and compressor industry.

Available from:

U.S. Department of Commerce
Bureau of the Census
Gaithersburg, MD
Phone: (301) 457-4100
Fax: (301) 457-4794

The report can be downloaded from the Census Bureau's Web site (<http://www.census.gov>).

The U.S. Pump and Compressor Industry

Author: Business Trend Analysts, Inc.

Description: This market research report assesses the market for pumps and compressors, including reciprocating, rotary, and centrifugal air compressors, by gathering data and conducting analyses. The report presents data on U.S. manufacturers' sales and analysis of end-use demand by industry for pumps and compressors. Additional information includes pump and compressor industry statistics, trade, corporate profiles, and a directory of manufacturers.

Available from:

Business Trend Analysts, Inc.
2171 Jericho Turnpike
Commack, NY 11725-2900
Phone: (516) 462-5454
Fax: (516) 462-1842

U.S. Stationary Compressors Market

Author: Frost & Sullivan

Description: This report provides forecast information for the entire U.S. compressor and vacuum pump market. Market forecasts are based on revenues and growth rates, unit shipments and pricing trends, competitive analyses, and market and technology trends. The market is also analyzed by examining advancements in technology, materials, and manufacturing processes. The market is comprised of major segments which include positive-displacement compressors and dynamic-type compressors.

Available from:

Frost & Sullivan
90 West Street, Suite 1301
New York, NY 10006
Phone: (212) 964-7000
Fax: (212) 619-0831

Brochures

The following brochures are available from the Compressed Air and Gas Institute at:

The Compressed Air and Gas Institute

1300 Sumner Avenue
Cleveland, OH 44115-2851
Phone: (216) 241-7333
Fax: (216) 241-0105
cagi@taol.com
www.taol.com/cagi

Air Compressor Selection and Application: 1/4 hp through 25 hp

Author: CAGI

Description: This publication provides a detailed summary of the types of compressors available, their intended application, and selection criteria for a variety of industries.

Compressed Air and Gas: An Introduction

Author: Lynn Adkins Guda

Description: This booklet presents a brief discussion of compressed air as an important means of transmitting power. It introduces compressed air and gas theory, compressors, and uses.

Compressed Air and Gas: In Manufacturing

Author: William D. Ellis

Description: This brochure describes the uses of compressed air in producing capital and consumer goods. Examples of compressed air use include lightweight pneumatic tools and controls on the assembly line and in automation.

Compressed Air and Gas: The Process Industries

Author: William D. Ellis

Description: This booklet discusses the role of compressors in the process industries, where products such as chemicals, pharmaceuticals, and plastics require large volumes of compressed air and gas for production.

Compressed Air and Gas Drying

Author: CAGI

Description: This brochure explains the need for air and gas drying. It includes a step-by-step dryer specifying guide, technical illustrations, and appropriate technical appendices.

Refrigerated Compressed Air Dryers-Methods for Testing and Rating

Author: CAGI

Description: This brochure provides a uniform procedure to measure and rate the performance of refrigerated compressed air dryers.

Rotary Air Compressor Selection Guide

Author: CAGI

Description: This publication covers the complete range of rotary air compressors and discusses selection criteria, capacity control, compressor accessories, and examples of applications.

Safety Aspects of Compressor Lubricants

Author: CAGI

Description: This publication discusses the safety aspects of petroleum-based and synthetic lubricants for air and gas compressors.

Periodicals

Compressed Air

Description: Compressed Air is Ingersoll-Rand's magazine of applied technology and industrial management and contains informative articles on compressed air and gas applications and other related technological innovations.

Available from:

Compressed Air
253 East Washington Avenue
Washington, NJ 07882-2495
Phone: (908) 850-7817
Fax: (908) 689-3095

Impact Compressor/Turbine News & Patents

Description: This newsletter (10 issues per year) describes new compressor/turbine patents and new developments in the compressor/turbine field. It includes listings of current articles, seminars, books, and industry news.

Available from:

Impact Publications
Ketchum, ID
Phone: (208) 726-2133
Fax: (208) 726-2155

Other Periodicals

The following magazines often contain articles about improving the performance of compressed air systems, and can be a very good source of state-of-the-art information:

- *AFE Facilities Engineering (Association of Facilities Engineering)*
- *Maintenance Technology*
- *Plant Engineering*
- *Plant Services.*

Software

AIRMaster: Compressed Air System Assessment Software

Description: AIRMaster is a software package that enables engineers, auditors, energy managers, and utility staff to assess the performance of their industrial compressed air systems. The latest version of this software, AIRMaster+, is in development and is projected to be available in late 1998. For more information and to request to be put on the AIRMaster+ mailing list, contact the Motor Challenge Information Clearinghouse.

Available from:

The Motor Challenge Information Clearinghouse
P.O. Box 43171
Olympia, WA 98504-3171
Phone: (800) 862-2086
Fax: (206) 586-8303
www.motor.doe.gov

C-MAX Engineering Software

Description: C-MAX™ software's compressor module is designed for systems analysis of centrifugal compressors, reciprocating compressors, and rotary screw compressors. Multiple compressors and "what if" case studies can be modeled for pure gases or gaseous mixtures such as dry or wet air, hydrogen, nitrogen, refinery gas mixture, fuel gas, and natural gas. The software allows users to perform "off-line" modeling of compressor performance, energy, and flow capacity calculations, and to create case studies by changing process, mechanical, or load variables. An evaluation copy is available on the Unicade web site.

Available from:

UNICADE INC.
13219 NE 20th Street, Suite 211
Bellevue, WA 98005-2020
Phone: (425) 747-0353
Fax: (425) 747-0316
Web: www.unicade.com
e-mail: unicade@unicade.com

CHEMCALC 15: Centrifugal Compressor Design and Rating

Description: Based on the theories of Elliott and Ingersoll-Rand, CHEMCALC 15 will: (1) design a compressor and analyze a multi-stage compressor with up to four stages of compression; (2) analyze the performance of an existing compressor by calculating new operating conditions based on design operating conditions and curve and actual process conditions; and (3) calculate the thermodynamic properties of a gas mixture, including molecular weight, critical temperature, critical pressure, specific heat ratio, and gas constant.

Available from:

Gulf Publishing Company Software
P.O. Box 2608
Houston, TX 77252-2608
Phone: (800) 231-6275, (713) 520-4448
Fax: (713) 520-4433

Compressed Air Survey

Description: The software is a comprehensive, interactive software tool designed to provide a quantitative assessment of a compressor system's operating costs and the potential efficiencies resulting from system improvements. The EPRI Compressed Air Handbook (CR-104546) accompanies the software.

Available from:

EPRIAMP
8000 Ravines Edge Court
Columbus, OH 43235-9939
Phone: (614) 846-7322
Fax: (800) 832-9267

Videos

Three videos are available from CAGI:

Compressed Air: Industry's Fourth Utility

Description: This video presents a broad overview of air compression, distribution, and treatment. It describes key considerations in designing and specifying a compressed air system, including compressor selection, distribution considerations, air dryers, and filters. (Running time: 13 minutes)

Performance Under Pressure

Description: This video discusses the role of compressed air and gas in various applications ranging from residential to industrial. (Running time: 16 minutes)

Principles of Air Compression

Description: In nontechnical terms, this video explains the theory and principles involved in air compression. It illustrates the operation of both positive-displacement and dynamic-type compressors and introduces key terms, such as PSIG, SCFM, relative humidity, and dew point, to the audience. (Running time: 14 minutes)

All available from:

The Compressed Air and Gas Institute
1300 Sumner Avenue
Cleveland, OH 44115-2851
Phone: (216) 241-7333
Fax: (216) 241-0105
cagi@taol.com
www.taol.com/cagi

Safety and Use of Air Compressors

Description: This video program shows how to operate an air compressor system safely and efficiently. Topics include moving the air compressor, compressor parts, lubrication, and maintenance. (Running time: 13 minutes)

Available from:

SafetyCare Inc.
26161 La Paz Road Suite A
Mission Viejo, CA 92691
Phone: (714) 452-1555
Fax: (714) 452-1556
<http://www.safetycare.com.au>

Workshops and Training Courses

Workshops focusing on energy efficiency and performance improvement in compressed air systems are developed and presented by independent consultants, equipment manufacturers, distributors, and others. Many compressed air system consultants offer workshops and training courses on improving the performance of compressed air systems. In addition, some equipment manufacturers and distributors offer training to their customers. Workshops are sometimes sponsored by electric utilities, universities, and state energy offices. The Compressed Air Challenge™ is developing a training program for plant operating personnel which will be piloted in early 1999 and available on a widespread basis by mid-1999. To get on the Compressed Air Challenge™ mailing list for future information, contact:

Energy Center of Wisconsin
595 Science Drive
Madison, WI 53711-1060
Phone: (800) 559-4776
Fax: (608) 238-8733

Glossary

Absolute Pressure — Total pressure measured from zero.

Absolute Temperature — See Temperature, Absolute.

Absorption — The chemical process by which a hygroscopic desiccant, having a high affinity with water, melts and becomes a liquid by absorbing the condensed moisture.

Adsorption — The process by which a desiccant with a highly porous surface attracts and removes the moisture from compressed air. The desiccant is capable of being regenerated.

Actual Capacity — Quantity of gas actually compressed and delivered to the discharge system at rated speed and under rated conditions. Also called Free Air Delivered (FAD).

Air Receiver — See Receiver.

Aftercooler — A heat exchanger used for cooling air discharged from a compressor. Resulting condensate may be removed by a moisture separator following the aftercooler.

Atmospheric Pressure — The measured ambient pressure for a specific location and altitude.

Automatic Sequencer — A device which operates compressors in sequence according to a programmed schedule.

Brake Horsepower (bhp) — Horsepower delivered to the output shaft of a motor or engine, or the horsepower required at the compressor shaft to perform work.

Capacity — The amount of air flow delivered under specific conditions, usually expressed in cubic feet per minute (cfm).

Capacity, Actual — The actual volume flow rate of air or gas compressed and delivered from a compressor running at its rated operating conditions of speed, pressures, and temperatures. Actual capacity is generally expressed in actual cubic feet per minute (acfm) at conditions prevailing at the compressor inlet.

Capacity Gauge — A gauge that measures air flow as a percentage of capacity, used in rotary screw compressors as an estimator during modulation controls.

Compression, Adiabatic — Compression in which no heat is transferred to or from the gas during the compression process.

Compression, Isothermal — Compression in which the temperature of the gas remains constant.

Compression Ratio — The ratio of the absolute discharge pressure to the absolute inlet pressure.

Constant Speed Control — A system in which the compressor is run continuously and matches air supply to air demand by varying compressor load.

Cubic Feet Per Minute (cfm) — Volumetric air flow rate.

Cfm, Free Air — Cfm of air delivered to a certain point at a certain condition, converted back to ambient conditions.

Actual Cfm (acfm) — Flow rate of air at a certain point at a certain condition at that point.

Inlet Cfm — Cfm flowing through the compressor inlet filter or inlet valve under rated conditions.

Standard Cfm — Flow of free air measured and converted to a standard set of reference conditions (14.5 psia, 68 °F, and 0 percent relative humidity).

Cut In/Cut Out Pressure — Respectively, the minimum and maximum discharge pressures at which the compressor will switch from unload to load operation (cut in) or from load to unload (cut out).

Cycle — The series of steps that a compressor with unloading performs; (1) fully loaded, (2) modulating (for compressors with modulating control), (3) unloaded, and (4) idle.

Cycle Time — Amount of time for a compressor to complete one cycle.

Degree of Intercooling — Difference in air or gas temperature between the outlet of the intercooler and the inlet of the compressor.

Deliquescent — Melting and becoming a liquid by absorbing moisture.

Desiccant — A material having a large proportion of surface pores, capable of attracting and removing water vapor from the air.

Dew Point — The temperature at which moisture in the air will begin to condense if the air is cooled at constant pressure. At this point the relative humidity is 100 percent.

Demand — Flow of air at specific conditions required at a point or by the overall facility.

Discharge Pressure — Air pressure produced at a particular point in the system under specific conditions.

Discharge Temperature — The temperature at the discharge flange of the compressor.

Efficiency, Compression — Ratio of theoretical power to power actually imparted to the air or gas delivered by the compressor.

Efficiency, Isothermal — Ratio of the theoretical work (as calculated on an isothermal basis) to the actual work transferred to a gas during compression.

Efficiency, Mechanical — Ratio of power imparted to the air or gas to brake horsepower (bhp).

Efficiency, Volumetric — Ratio of actual capacity to piston displacement.

Free Air — Air at atmospheric conditions at any specified location, unaffected by the compressor.

Full-Load — Air compressor operation at full speed with a fully open inlet and discharge delivering maximum air flow.

Gauge Pressure — The pressure determined by most instruments and gauges, usually expressed in psig. Barometric pressure must be considered to obtain true or absolute pressure.

Horsepower, Brake — See Brake Horsepower.

Horsepower, Theoretical or Ideal — The horsepower required to isothermally compress the air or gas delivered by the compressor at specified conditions.

Humidity, Relative — The relative humidity of a gas (or air) vapor mixture is the ratio of the partial pressure of the vapor to the vapor saturation pressure at the dry bulb temperature of the mixture.

Humidity, Specific — The weight of water vapor in an air vapor mixture per pound of dry air.

Indicated Power — Power as calculated from compressor-indicator diagrams.

Inlet Pressure — The actual pressure at the inlet flange of the compressor.

Intercooling — The removal of heat from air or gas between compressor stages.

Leak — An unintended loss of compressed air to ambient conditions.

Load Factor — Ratio of average compressor load to the maximum rated compressor load over a given period of time.

Load Time — Time period from when a compressor loads until it unloads.

Load-Unload Control — Control method that allows the compressor to run at full-load or at no load while the driver remains at a constant speed.

Modulating Control — System which adapts to varying demand by throttling the compressor inlet proportionally to the demand.

Perfect Intercooling — The condition when the temperature of air leaving the intercooler equals the temperature of air at the compressor intake.

Piston Displacement — The volume swept by the piston; for multistage compressors, the piston displacement of the first stage is the overall piston displacement of the entire unit.

Pneumatic Tools — Tools that operate by air pressure.

Pressure — Force per unit area, measured in pounds per square inch (psi).

Pressure Dew Point — For a given pressure, the temperature at which water will begin to condense out of air.

Pressure Drop — Loss of pressure in a compressed air system or component due to friction or restriction.

Pressure Range — Difference between minimum and maximum pressures for an air compressor. Also called cut in-cut out or load-no load pressure range.

Rated Capacity — Volume rate of air flow at rated pressure at a specific point.

Rated Pressure — The operating pressure at which compressor performance is measured.

Required Capacity — Cubic feet per minute (cfm) of air required at the inlet to the distribution system.

Receiver — A vessel or tank used for storage of gas under pressure. In a large compressed air system there may be primary and secondary receivers.

Relative Humidity — The ratio of the partial pressure of a vapor to the vapor saturation pressure at the dry bulb temperature of a mixture.

Sequence — The order in which compressors are brought online.

Specific Humidity — The weight of water vapor in an air-vapor mixture per pound of dry air.

Specific Power — A measure of air compressor efficiency, usually in the form of bhp/100 acfm or acfm/bhp.

Specific Weight — Weight of air or gas per unit volume.

Standard Air — The Compressed Air & Gas Institute and PNEUROP have adopted the definition used in ISO standards. This is air at 14.5 psia (1 bar); 68 °F (20 °C) and dry (0 percent relative humidity).

Start/Stop Control — A system in which air supply is matched to demand by the starting and stopping of the unit.

Surge — A phenomenon in centrifugal compressors where a reduced flow rate results in a flow reversal and unstable operation.

Temperature, Absolute — The temperature of air or gas measured from absolute zero. It is the Fahrenheit temperature plus 459.6 and is known as the Rankine temperature. In the metric system, the absolute temperature is the Centigrade temperature plus 273 and is known as the Kelvin temperature.

Temperature, Discharge — The total temperature at the discharge connection of the compressor.

Temperature, Inlet — The total temperature at the inlet connection of the compressor.

Temperature Rise Ratio — The ratio of the computed isentropic temperature rise to the measured total temperature rise during compression. For a perfect gas, this is equal to the ratio of the isentropic enthalpy rise to the actual enthalpy rise.

Temperature, Static — The actual temperature of a moving gas stream. It is the temperature indicated by a thermometer moving in the stream and at the same velocity.

Temperature, Total — The temperature which would be measured at the stagnation point if a gas stream were stopped, with adiabatic compression from the flow condition to the stagnation pressure.

Theoretical Power — The power required to compress a gas isothermally through a specified range of pressures.

Torque — A torsional moment or couple. This term typically refers to the driving couple of a machine or motor.

Total Package Input Power — The total electrical power input to a compressor, including drive motor, cooling fan, motors, controls, etc.

Unload — (No load) Compressor operation in which no air is delivered due to the intake being closed or modified not to allow inlet air to be trapped.

Appendix A: Compressed Air System Survey at Picatinny Arsenal

Executive Summary

The purpose of the site assessment is to determine if Picatinny Arsenal has the desired characteristics to be selected for the "Demonstration of Natural Gas Engine Driven Air Compressors at Department of Defense Industrial Facilities" (NGEDAC). The NGEDAC initiative is managed by the U.S. Army Construction Engineering Research Laboratory (CERL) and is being implemented by Technology and Management Services, Inc. (TMS) and Xenergy, Inc. The site assessment was conducted during the week of 28 August 2000.

The preliminary assessment provides an overview of the facility's compressed air system, outlines potential areas for reducing system demand, evaluates the general economics of a gas driven system at the site, and identifies potential benefits or problems associated with implementing a gas driven system. The preliminary assessment concludes that the Picatinny Arsenal is a good candidate for additional consideration as a demonstration site.

Current air flow of the main system is approximately 925 acfm at a supply pressure of 80 psig with an annual energy cost of \$100,000. This figure is a reduction of \$25,000 that had been previously achieved by operating personnel who lowered the final discharge pressure to the system from 100 psig to 80 psig. In moving forward, potential reductions in air leaks and the level of production air supplied during nonproduction periods could decrease air requirements by 500 acfm or an additional \$42,000, leaving an annual energy bill of \$58,000 (Figure A1). Such a reduction level is realistic and will be verified by a leak study if the Picatinny site is selected for a Detailed Assessment Study.

Other demand-related aspects that will be investigated are the feasibility of shutting down the main system during nonproduction periods, closing off sections of the distribution system instead of repairing the associated leaks, and reviewing several cost saving opportunities associated with the Arsenal's subsystems for compressed air.

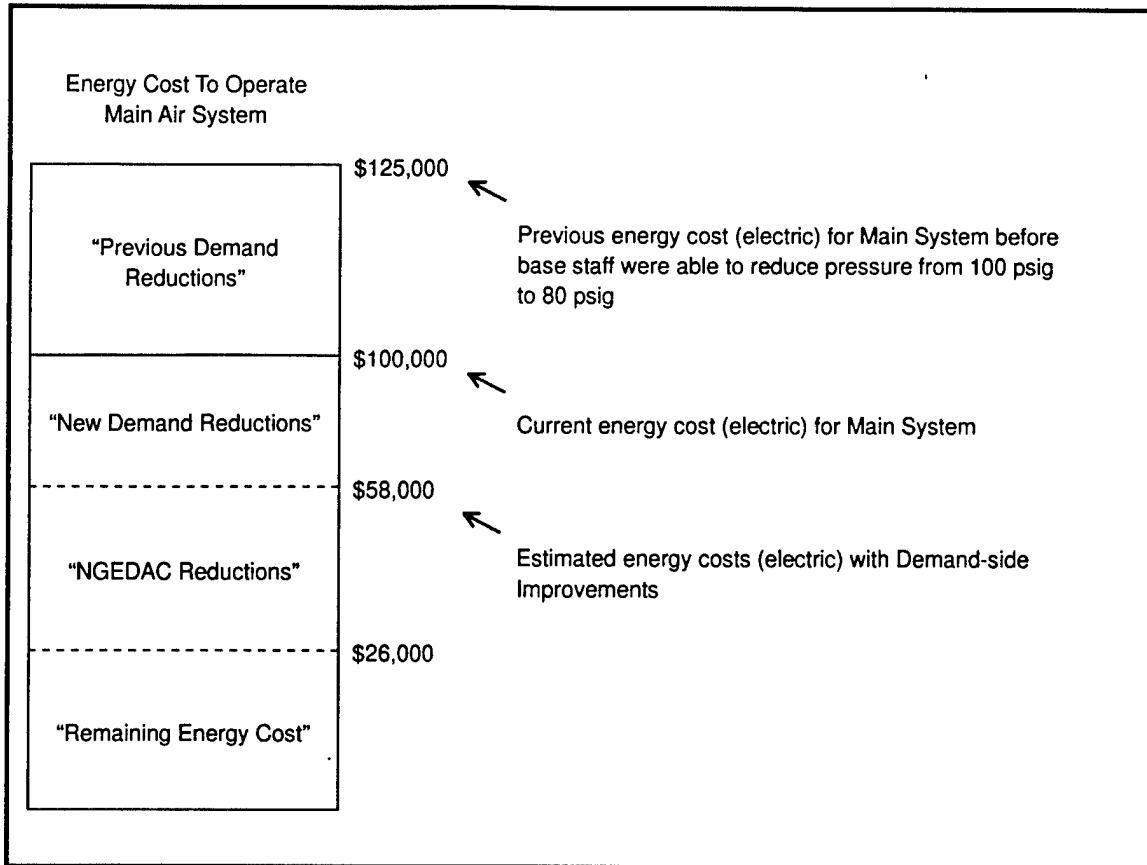

Figure A1. Potential savings due to reductions in air leaks and the level of production air supplied during nonproduction periods.

The Picatinny site demonstrates favorable economic conditions for implementation of a gas engine driven system. Such a system is estimated to save \$32,000 annually in fuel costs based on an interruptible gas supply price of \$3.41 per million Btu. The gas driven engine system would incur \$11,000 in incremental annual maintenance costs based on a 2-year maintenance contract for the gas system. The resulting net operating cost of the gas system is \$21,000 less than the current electric system.

Preliminary estimate of the installed system cost for the gas technology is approximately \$160,000. This estimate could vary up or down depending on specific installation conditions and/or desired equipment features. For example, an air-cooled engine feature would add about \$4000 to the system cost, but may be otherwise beneficial. System environmental emission levels are based on limits of 0.70 gm/bhp/hr for NO_x and 0.48 gm/bhp/hr for CO.

The total estimated project cost does not include any potential electrical demand reduction rebates for which this project may qualify. This issue will be investigated during the Detailed Assessment Study and after the Arsenal has obtained

approvals for the TMS Team to discuss such opportunities with the appropriate utility or state staff.

Other supply-related issues to be investigated include definitively firming final price of natural gas, addressing potential environmental issues that currently appear to be minimal, and finalizing the overall equipment requirements so price estimates can be formalized.

The Picatinny site has a number of other positive aspects that help make it a good demonstration site candidate. Gas supply is readily accessible. Physical space is available and plant modifications would be minimal. Experience and confidence gained by Arsenal staff and contractors in developing and operating the 2.2 MWe gas-fueled cogeneration system are a significant plus and may help reduce cost estimates for maintenance contracts for the gas engine compressed air system.

The Picatinny site provides for a fairly straightforward technology application and demonstration with a very manageable system size. It affords the Department of Defense an excellent opportunity to test operating a "gas/electric hybrid system." In addition, the Arsenal would be provided an opportunity to gain experience in using energy savings performance contracting (ESPC) vehicles for implementing the recommended system optimization improvements which are outside the scope of this NGEDAC project, but are essential in properly sizing the project's gas engine system and reducing the overall operating costs of Picatinny Arsenal.

Section 1. Compressed Air System Overview

Introduction

The compressed air system at Picatinny Arsenal encompasses an extensive geographical area. Today, there are almost 27 miles of compressed air piping, joining 15 to 16 areas of production buildings. With air usage levels significantly less than those required during the height of production at the Arsenal, there are numerous opportunities to improve energy efficiency in the system and to further reduce system operating costs by implementing a gas engine driven compressed air system.

The main compressed air system is fed by a compressor plant in the main Power House Building 506. Average flow for the main system is 925 acfm at 80 psig with the system operating 8760 hours per year. The air delivered from the

Power House is dried only with a water-cooled aftercooler. When the site visit took place on a 79 °F ambient day, the compressed air system was delivering 80 °F saturated air at 80 psig to the system.

There are three other independent compressed air systems:

1. *Wind Tunnel*. A special application for projectile testing at supersonic, transonic, and subsonic speeds. This system requires higher pressure (110-120 psig) and significant storage (16,000 cu ft) for proper operation. Average flow for the Wind Tunnel system is 2200 acfm. The system operates 500 hr per year.
2. *Building 3150 (Machine Shop)*. This building houses a large machine shop and runs with its own air compressor supply. Average flow is 20 acfm with the system operating 8760 hours per year. There is no feeder line from the main air system to this building.
3. *Building 3028*. This building also has no feed from the main air supply and currently has its own air system. Average flow is 40 cfm with the system operating 8760 hours per year.

There are also several dedicated systems in the Main Power House: one for engine starting of the 12-cylinder Caterpillar natural gas engine generator/fuel cell power system and one for the instrument air and HVAC control systems.

There are other dedicated control and fire suppression compressed air systems throughout the Arsenal. In general, these units are small horsepower duplex units with compressed air dryers. They do not normally run many hours a year and are not part of the main air system. These are not included in the system evaluation of this report.

In summary, Picatinny Arsenal has a large volume air system that is currently supplying a relatively small system demand. This "system downsizing" presents many opportunities for energy savings that are addressed in this report.

Previous System Improvements

The Arsenal personnel have already implemented several key programs that have successfully lowered the energy cost.

Power House (506)

Operating personnel have lowered the final discharge pressure to the system from 100 psig to 80 psig. This has reduced electrical demand by approximately

31.69 kW resulting in savings of \$24,430 per year. Today the system still runs effectively at this reduced pressure level.

Building 3150

This system previously ran a 100 hp, 490 acfm Quincy Rotary Screw Compressor with apparent demand of 40 cfm or less, running 10 percent loaded continuously. This was a very inefficient mode of operation and resulted in excessive wear on the compressor. The system operated at 59.4 kW with an annual energy cost of \$45,790.

Today the machine shop typically runs two small 4.7 hp tank-mounted units. Ten of these units (IMC) are located strategically around the building. The operating pairs are alternated as required. These units operate at 14.21 kW. Since they are commercial as opposed to industrial units, the motors are a low-efficiency, single-phase type. Today, the operating cost of \$10,923 per year results in savings of \$34,867 per year.

Building 3028

This building previously ran a 40 hp/35 kW 150 cfm Ingersoll Rand ESV nonlubricated, double-acting, water-cooled, single-stage compressor. At 40 cfm demand, this unit operated at 13.2 kW for a cost of \$10,175 per year.

Today, air is supplied by a 25 hp Ingersoll Rand Model 3000, delivering 100 cfm at 100 psig at 27 bhp/22.8 kW. At 40 cfm average demand, this unit operates at approximately 8.8 kW over 8760 hours or \$6791 per year operating cost, a net savings of approximately \$3384 per year.

System Load Profile and Cost Analysis

Based on optimum performance of each compressor—compared to Load Cycle—and on discussions with plant personnel, load profiles and power usage assessments were developed for each of the main compressed air systems (Table A1).

Table A1. Load profiles and power usage assessments for main compressed air systems at Picatinny Arsenal.

	Main Power House	Wind Tunnel	Bldg 3028	Bldg 3150	Total
Average System Flow	900 acfm	2,200 acfm	40 acfm	20 acfm	NA
Average Prod kW	126.75 kW	356.28 kW	14.21 kW	8.8 kW	NA
Annual System Operating Hrs	8760 hrs	500 hrs	8760 hrs	8760 hrs	NA
Specific Power	7.1 cfm/kW	6.17 cfm/kW	2.81 cfm/kW	2.27 cfm/kW	NA
Energy Cost -- \$ cfm/yr	\$108.57 cfm/yr	\$7.13 cfm/yr	\$274.33 cfm/yr	\$339.95 cfm/yr	NA
Air Energy Cost - \$ psig/yr	\$488.54 psig/yr	\$78.49 psig/yr	\$54.77 psig/yr	\$37.30 psig/yr	NA
Est Air Energy Cost - \$/yr	\$99,487 /yr	\$15,689 /yr	\$10,973 /yr	\$6,791 /yr	\$132,940/yr

Note: Blended Power Rate = 0.088 kWh; Power House Operating Pressure = 80 psig.

Measured Flow

Flow and pressure were measured for 24 hours beginning the morning of 29 August 2000. The flow measurement was taken with a Sierra-heated wire anemometer (0-20,000 fpm ± 3 percent). Readings were taken (on average) every 11 seconds. The curve shown is with these readings averaging every 10 minutes (Figure A2).

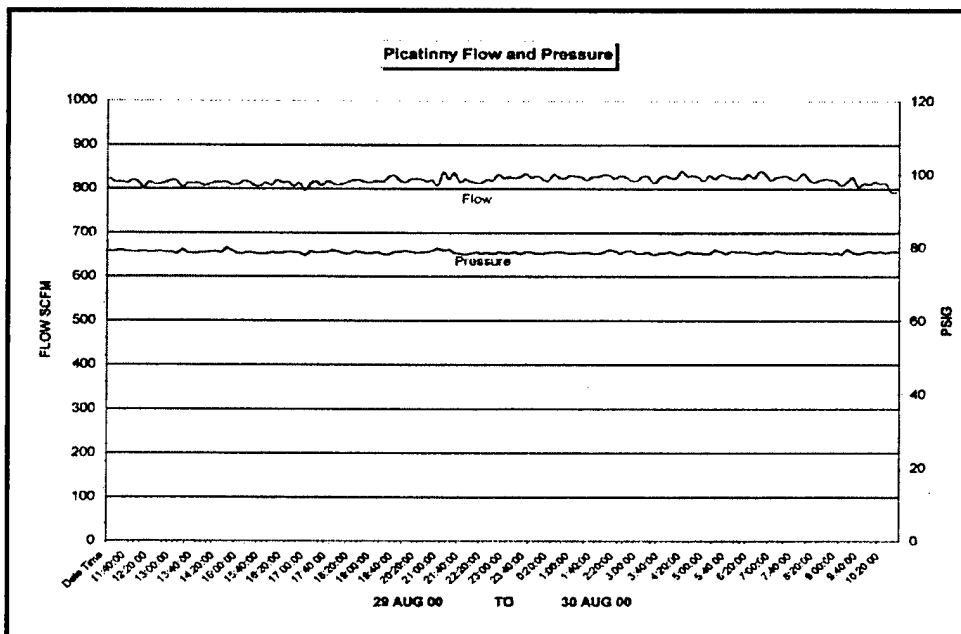

Figure A2. Picatinny CA flow and pressure.

The trended curve shows 800 scfm (900 acfm) in a continuous demand over the 24-hour period, both during production and nonproduction periods. Picatinny is essentially a one-shift operation. This indicates a significant number of leaks and/or process air "left on" during nonproduction hours. Both of these conditions represent an energy savings opportunity (refer to the Leak Management section). Arsenal personnel are in the process of determining which production activities were operating and which were not. This information will help determine the source and level of opportunity.

Pressure

The pressure was recorded at the same trending rates and at the same point as the flow. The pressure transducer was zeroed out against a calibrated Helcoild DP250 digital test gauge. The pressure held a steady 79 to 80 psig during the entire test.

The actual plant electrical power cost for the combination of the main system and satellite subsystems, as running today, is in excess of \$130,000 per year. The load profile or demand of this system is almost like "process air" and is relatively stable during all shifts. The full load operating range is 365 days a year, 24 hours a day, 8760 hours a year (see flow meter readings).

There are no significant cost savings within the current air supply configuration for the main Power House, except for the potential for moving to gas engine drives. Moving the subsystems associated with Buildings 3028 and 3150 to the main system would save roughly \$13,000 annually based on being to supply at an incremental cost of \$80 per cfm relative to the current cost averaging \$300 per cfm for the 60 cfm requirement.

Other Issues

The electrical power cost per hour per "loaded cfm" of air used was determined. Electrical power cost is used as a qualifying factor since it is "real bottom line dollars." This is an absolute number and not a subjective or opinion. All paybacks for savings projects are estimated using the "full load operating efficiencies," which are very conservative.

If the compressed air is not used, the compressor either shuts off or unloads. If it shuts off, there is a 100 percent saving of the power cost. If it unloads, there is a 25 to 90 percent savings of the power cost.

It is important to note that all recoverable compressed air costs should also be considered, i.e., maintenance, water costs, depreciation, etc. Usually, the electrical power cost is between 50 and 75 percent of the total "variable compressed air costs." Associated maintenance and other costs will be, in all probability, at least 50 percent or more of the identified electrical power cost. Existing records may be available to estimate these more accurately.

Plant Compressed Air Survey

The primary objective of the survey was to review the basic system dynamics and identify the current basic load/power profile and then to project what it will be when optimized with this data. The objective is to size and recommend an appropriate natural gas engine-driven compressor to effectively carry the base load and optimize the natural gas engine savings over conventional electric driven units. This action is to evaluate this Arsenal's operating characteristics to reflect accurate and effective results with a natural gas engine driven air compressor demonstration unit.

Some specific selected steps were identified:

- Determine the follow-up plans and actions appropriate to lower the overall compressed air energy cost in the continuing short and long terms.
- Evaluate the potential energy cost savings in compressed air demand side conservation programs:
 - Leak control/management;
 - Specific demand side requirements.
- Review appropriateness of compressed air equipment to produce proper quality and quantity of usable compressed air power at the acceptable efficiency.
- Identify a relatively accurate load profile.
- Identify your current electric power cost per cfm and per psig to calculate anticipated return.
- Key concepts to consider if a Level II Audit is implemented:
 - Identify and target opportunities for compressed air savings on the demand side.
 - Outline plans for point of use pressure and quality management.
 - Evaluate characteristics and appropriateness of central compressed air control system.
 - Identify savings potential in use of air saving devices—nozzles and auto drains.
 - Identify savings potential in replacement or re-evaluation of "misapplied air"—cabinet coolers, vacuums, pumps, and bearing cooling.
 - Review total piping system and leaks. Develop action plan to remove as much pipe as possible, then repair leaks on what is left.

Above-Ground Leak Needing Immediate Repair

Note that during the site visit, a significant air leak was identified in an above-ground, rusted-out distribution line under enclosed walkway between Building 807 and Building 810. This creates a USEPA violation (oil in ground) and a significant "safety issue" (possible blowout). The audit team pointed this out to Arsenal personnel on site and at the "wrap-up" meeting and recommend this leak and any others like it be "corrected immediately."

Section 2. Current System Review

Power House Building

506 Main Compressor Room Supply

The basic air supply consists of running either compressor Unit 1 or 2. Unit 1 is currently not operational. Both units are 18 ½-in. and 11 ½-in. x 8 ½-in. stroke, double-acting reciprocating Ingersoll Rand 200 bhp (1130 acfm at 100-110 psig) compressor with 5-step unloading.

These units are the most power efficient units on the Arsenal and have a capacity control system, which effectively translates lower air demand with lower input energy.

The audit team observed Unit 2 running and except for a little too much oil from the oiler, it appeared to be in very good shape. These units are applied excellently and there are no more power efficient units available in this size class. They are still state-of-the-art systems.

Main Compressor Room

The back-up air is supplied by:

- *75 hp Atlas Copco*. Two-stage, water-cooled, single-acting DR 2 compressor with water-cooled heads and jackets. This unit is smaller and is 10 percent less driver efficient than the XLE. Parts are usually hard to obtain for these since they are manufactured in Belgium. The unit should be run as little as possible.
- *40 hp Gardner Denver*. WXE air-cooled delivering 157 acfm at 41 BHP. It is also a 2-stage, single-acting unit and relatively old. It is also 10 percent less efficient than the XLE and should be run as little as possible.

- *25 hp Champion R70-12.* 25 hp two-stage, single-action, tank-mounted (120 gal) reciprocating compressor delivering 91 cfm at 27 BHP. This unit is 15 percent less efficient than the XLE and should be run as little as possible.

These three back-up units will certainly not be required in the future if the NGEDAC unit is installed and the system is optimized, unless a significant low load condition occurs. Consideration should be given to using these units at selected places within the production areas, if required.

Compressor Capacity Controls

The most effective way to run an air compressors is either to let it run at full load, or to turn it off. Capacity controls are methods of restricting the output air volume delivered to the system, while the unit is still running—in other words, by running the compressor at less than full load. This is always a compromise, and on a specific power (cfm/hp) basis, is never as efficient as full load.

Reciprocating Controls

The main Power House base reciprocating compressor is a double-acting, water-cooled unit with five-step unloading. This is an efficient compressed air unloading system, reciprocating five-step unloading will efficiently translate percentage of “less air used” into almost a comparable reduction in energy cost.

Rotary Screw Controls

The two most common controls used are modulation and online/offline. Modulation is relatively efficient at very high loads—and very inefficient at lower loads. Online and offline is a very efficient commercial control available for loads below 60 percent when properly applied with adequate time for blow down. There are several other (“rotor length adjustment” or “variable displacement,” and “variable speed drive”) that have very efficient turn down from 100 percent load to about 60 percent load.

These controls must be installed properly to operate correctly and efficiently. The installation should have piping and storage available close to the unit with no measurable pressure loss at full load to allow the signal to closely match the air requirements. Also the systems at Picatinny have some modulation units (Sullair) and some online/offline (Atlas Copco). All appear to be installed properly and run correctly.

Recommendations—Short Term

All of the units involved have or are very close to having unloading controls capable of translating “less air used” into a comparable reduction in power cost. These controls will work effectively with your current piping and air receiver storage situation.

Recommendations—Long Term

With the system stabilized and balanced in the main Power House (506), consider a microprocessor-driven centralized full networking electronic control system. This will automatically place the most efficient machine online and assure no more than one partial loaded unit at a time.

Air Treatment and Air Quality

General Air Treatment Concepts

Eliminating Water/Oil in Air Systems

The correct way to eliminate water and oil in your air system is to clean and dry the air immediately after it is produced in the compressor room. Then store clean dry air in a separate air receiver and flow it to the system as required.

Addressing Water and Oil Carryover Problems in a Compressed Air System

The water (condensate) and oil carryover problems in an air system are real and we can expect them to increase in magnitude in the extreme weather. Some guidelines regarding water and oil carryover control in compressed air systems are:

1. Generally, it is best to eliminate the water and oil at the air source before it enters the air system.
2. Every 20 °F increase in temperature doubles the “moisture load” the compressed air will hold.
3. Compressed air dryers are usually capacity rated with 100 °F, 100 psig inlet air conditions. At 120 °F, 100 psig, the dryer’s capacity rating is reduced by 50 percent.
4. Putting “dry or oil free” air into your system 90 percent of the time and then allowing wet/oily air in sporadically 10 percent of the time will, in reality, give you a “wet/oily” system all the time. The liquid water and/or oil will fall out in the

pipng system continuing to "re-entrain" and contaminate and/or collected in the "low spots" of the system, thus recontaminating as it is pulled into the flowing compressed air system. A wet/oily system may well take many months of continued flow of clean dry air to "clean up."

5. Identify required pressure dew point.

Refrigerated Air Dryers

Refrigerated dryers require a refrigeration system to mechanically cool the air. The lowest possible consistent pressure dew point with a noncycling dryer is +40 °F. Cycling dryers not only save power (60 to 75 percent), but also can deliver a lower pressure dew point (down to +35 °F to + 38 °F). Picatinny has some refrigerated dryers throughout the system, most in the dedicated control/fire air systems.

Desiccant Dryers

Desiccant dryer regeneration types remove moisture vapor by "adsorbing" it to activated alumina desiccant beads. These dryers can consistently deliver a pressure dew point to -40 °F or lower, which removes much more water than conventional refrigeration units. To regenerate the wet tower while the other tower is drying, requires the use of heat in some form and some dry air to "sweep" or "purge" the exchanged moisture out. Desiccant dryers are usually rated at the same 100 °F inlet, 100 psig conditions.

Current Air Treatment System

The only dryers noted were in the dedicated systems:

- Wind Tunnel – desiccant
- Engine Starting – desiccant
- Instrument Air/Control Air – desiccant and refrigeration.

All these dryers are sized to their specific application and must have their own air supply. These units normally run a very limited number of hours per year, and therefore, offer few significant opportunities for energy recovery. Nothing observed would change this opinion. If in the future this changes, then that operation should be reviewed again.

The main Power House air is dried by water-cooled aftercoolers delivering 80 °F saturated on a 79 °F day, about as good as one might expect. The smaller units

throughout the system have appropriate air- or water-cooled aftercoolers that appear to be satisfactory.

The Wind Tunnel use outside-mounted air-cooled after cooler to a dryer. This appears to work very well.

There are no compressed air line filters in the main Power House air (506).

Basic System Header/Piping and Interconnecting Piping Between the Primary Air Compressors and the Distribution System

Basic Header Piping

Headers were checked at appropriate points with a single test gauge and there was little or no pressure loss in the header systems. Consequently, it is believed that the header system today can deliver the required air to any area without any significant pressure loss. Any low-pressure problems encountered will, in all probability, be in the feeds from the header to the area. The header runs between building is long, extensive, and old. Leaks resulting from holes rusted through the pipe not only lose air, but create safety problems as well.

Interconnecting Piping

Air is being delivered from the compressors to the interconnecting piping ranges between 78 and 80 psig and getting into the main air system at 78 to 80 psig. This is an apparent pressure loss of 0 psig, which is very good.

Flow Regulation At The Process

Some flow regulators are probably set higher than the feed pressure required by the process, and some are left wide open to full header pressure. In this type of operation, it is very important that the actual inlet pressure to the process be known and that the lowest effective pressure be held steady for the proper product quality. Picatinny may need to install storage bottles downstream of the regulator to "close up" the pressure readings at rest and at operation. The minimum effective pressure at operation for each product run, established at the unit, needs to be established and adhered to.

Auto Condensate Drains

Automatic drain traps come in three categories. Level Operated Mechanically Activated Drains do not waste air, but are prone to clogging and require continu-

ing maintenance to assure operation. These work best in a "Power House situation" where continuing regular attention is part of the system.

Dual Timer Electronic Drains use an electronic timer to control the number of times per hour it opens and the duration of the opening. The theory is that you adjust the times to be sure to fully drain the condensate and minimize the open time without water that wastes compressed air. The reality is that the cycles either do not get reset from the original factory settings (which causes condensate build up in the summer) or they get set wide open and not closed down later in cooler weather thus wasting more air. When they "fail open," they blow at a full flow rate of about 100 cfm.

Consider that the usual factory setting is 10 minutes with a 20-second duration. Consider that 1500 scfm of compressed air will generate about 63 gal/day in average weather or 2.63 gal/hour. Each 10-minute cycle will have 0.44 gal to discharge. This will blow through a ¼-in. valve at 100 psig in approximately 1.37 seconds. Compressed air will then blow for 18.63 seconds each cycle, 6 cycles a minute will equal 111.78 seconds per hour of flow or 1.86 minutes per hour of flow. This will waste about 3.1 cfm. A 1/8-in. valve will pass about 100 cfm. The total flow will be $100 \times 1.86 = 186$ cu ft in 1 hr \times 60 minutes = 3.1 cu ft/min average. Energy cost/lost air = \$310 /year/valve.

Level Operated/Electronic Drains can receive the signal to open from the condensate high level and the signal to close from the condensate low level. These waste no air and (from a power cost standpoint) are the best selection and their reliability is usually many times greater than the level operated mechanical.

There is no doubt that automatic drain traps are a much better idea than manual drains for Picatinny's circumstance. The Arsenal should take the following action:

- For air conservation and enhanced performance, all dual timer electronic drains and manual drains should be replaced by level-actuated electronic or air-operated drains. Timer-activated drains or dual-timer drains may not be able to handle "heavy loads" of condensate unless continuously "monitored during the summer conditions."
- Be sure your auto drains are set up to work effectively, for examples:
 - Drains should not be tied together to a common header
 - Be sure all drains can be checked easily for operation
 - Be sure all drains are properly "vented."

The survey of the condensate handling system revealed several issues. Arsenal personnel stated that the condensate goes to a mechanical oil/water separator

and then to the storm sewer and lake. According to plant personnel, the discharge is monitored constantly to assure no USEPA violation. If this is always in effect, there is no apparent problem.

If Picatinny is discharging filtered condensate to a storm sewer or in some other manner to ground water (the USEPA minimum is 10 ppm), or if the Arsenal is required to separate it by local water treatment facility, this issue should be discussed in detail.

Leak Management Programs

With a campus facility of this type, an effective leak control program could well save in the average range of 300 to 400 cfm, which could potentially result in an annual power cost savings of \$30,000 to \$40,000. The estimated recoverable value is \$25,000 /yr.

To effectively control and manage leaks in such an extensive operation as Picatinny Arsenal, a continuing economical program must be in place. Generally speaking, the most effective programs are those that involve the production supervisors and operators working positively with the maintenance personnel.

Accordingly, the TMS Team recommends:

- In the short-term, set up a continuing leak inspection by Maintenance Personnel so that for a while, each primary sector (see drawing) of the plant is inspected once a quarter or at a minimum, once every 6 months to identify and repair leaks. A record should be kept of these findings and overall results.
- In the long-term consider setting up programs where the production people (particularly the operators and their supervisors) are positively motivated to identify and repair these leaks. The Project Cost Section includes a quotation for your information on a very effective ultrasonic leak locator.
- The Project Cost Section also lists some electric-operated automatic ball valves that can be installed in the main feed line to a piece of equipment and be wired in so as to open and close when the machine is powered up or shut off and thus eliminate off-production leaks and open air left on.

Cabinet Coolers

There may be cabinet coolers in use in the facility. Some with refrigeration (1500 Btu), some with compressed air-driven vortex coolers; and some may just have compressed air blowing into them. These all may be able to be replaced with "heat tube" cabinet coolers with a potential savings of 3.5 to 4 kW each.

The initial cost for this range is usually in the \$700 to \$750 range with a potential resultant electric savings of \$1000 to \$2000/year each.

Blow Offs

Picatunny may have 1/8-in. and 1/4-in. lines running as blow off on units at 80 psig. These will use 8 to 35 cfm each.

An alternate is an air amplifier that takes less compressed air and through Venturi action amplifies the usable air by pulling in significant amounts of ambient air and mixing it directly into the air stream. These have amplification ratios up to 25:1. Using 10 cfm of compressed air would generate a savings of 25 cfm compressed air per 1/4-in. blow off and flow 250 cfm total air at the process.

For example, 1/4-in., 1-ft-long tube will flow 35 cfm at 80 psig inlet, at an annual cost power of \$3500/yr/ea. Place a variable flow Venturi nozzle to amplify flow on the end of this tube and it will now only use 10 cfm and flow 250 cfm at the work. Table A2 summarizes the associated costs.

Vacuum Generators

Production may use vacuum generators, which are:

- convenient
- responsive
- inefficient compared to positive displacement pumps, e.g., rotary screw, reciprocating.

Note that energy cost escalates as vacuum goes down with Venturi generators. Energy cost also falls as vacuum goes down after about 14 in. with positive displacement pump. It is very important to only run a Venturi vacuum generator to a minimum vacuum and a minimum acceptable "on time" cycle at the lowest possible pressure.

For example, if generator uses 60 scfm at 80 psig, it can pull a 20-in. vacuum in about 0.25 seconds. If shut off at 20-in. vacuum, total air demand will be about 0.25 scfm with Energy Cost = \$25 /yr. If allowed to run continuously, air usage 60 scfm with Energy Cost = \$6000 /yr.

Table A2. Costs associated with tube / nozzle change to alter blowoff configuration.

Parameter	Cost
Annual power cost of one ¼-in. tube (continuous)	\$3500 /yr/each
Annual power cost of one venturi nozzle (continuous)	\$1000 /yr/each
Energy cost saved	\$2500 /yr/blow off
Recoverable energy cost	\$1750 /yr/blow off
Nozzle cost	\$17
Annual power cost of one ¼-in. tube (10% use)	\$350 /yr/each
Annual power cost of one venturi nozzle (10% use)	\$100 /yr/each
Energy cost saved	\$250 /yr/blow off
Recoverable energy cost	\$175 /yr/blow off
Nozzle cost	\$17

Air-Operated Diaphragm Pumps

Air-operated diaphragm pumps are generally used because they tolerate aggressive conditions relatively well and run without catastrophic damage even if the pump is dry. Efficiency is not usually considered.

There are several areas to pursue here in the future to perhaps generate significant air savings:

- Is the air-operated diaphragm pump the right answer? An electric pump is significantly more power efficient. Electric motor driven diaphragm pumps are available.
- Consider the installation of electronic or ultrasonic controls to shut the pumps off automatically when they are not needed. Remember the pump uses the most air when it is pumping nothing.
- Is Picatinny running most of the time at the lowest possible pressure? The higher the pressure, the more air used. For example, in a filter pack operation, the pump often does not need high pressure except during the final stages of the filter packing cycle. Controls can be arranged to accomplish lower pressure in the early stages and higher pressure later, which may generate significant savings.

Misapplied High Pressure Air

High pressure air being used for very low pressure applications is not an efficient use of energy. A close review of your system should be made and measurements taken to identify if there is any potential energy savings in using an alternate source of low pressure air in the production area.

Appendix B: Compressed Air System Survey at Watervliet Arsenal

Executive Summary

The purpose of the preliminary site assessment was to determine whether Watervliet Arsenal has the desired characteristics to be selected as a demonstration site under the project "Demonstration of Natural Gas Engine Driven Air Compressors at Department of Defense Industrial Facilities" (NGEDAC). The NGEDAC initiative is managed by the U.S. Army Engineer Research and Development Center (ERDC), Construction Engineering Research Laboratory (CERL) and is being implemented by Technology and Management Services, Inc. (TMS) and Xenergy, Inc. The preliminary assessment provides an overview of the facility's compressed air system, outlines potential areas for reducing system demand, evaluates the general economics of a gas driven system at the site, and identifies potential benefits or problems associated with implementing a gas driven system. The site assessment was conducted during the week of 30 October 2000.

The preliminary assessment concludes that the Watervliet Arsenal is a good candidate for additional consideration as a demonstration site. Initial consideration for locating the unit is in Building 110 along the South Wall.

The current air flow of the main system is approximately 2000 to 2500 acfm at a supply pressure of 83 to 85 psig. When the site visit was conducted, the main centrifugal compressor was not in operation. The estimated annual energy costs to operate the existing compressed air system is \$306,000 when the centrifugal unit is operating (the normal situation) and \$277,000 when the centrifugal unit is off line (the situation on the day of the site visit).

Based on an interruptible gas supply cost of \$5.00 per million Btu, using NGEDAC technology to supply about two-thirds of the compressed air demand at Watervliet will reduce energy costs to \$200,000 annually. This reduction translates into an energy savings of \$106,000 relative to the costs associated with the normal operating configuration using the centrifugal unit and \$77,000 relative to

the costs associated with the centrifugal unit off-line. A change in the price of natural gas of \$1 per million Btu, will change the level of savings by \$25,000.

If the Arsenal moves forward with a Level II Assessment, two specific demand reduction strategies should be explored. Potential reductions in air leaks on the order of 300 cfm could save \$22,000 in annual operating costs. The use of low-pressure air or blowers for agitator applications could save even more

Maintenance costs for the NGEDAC technology are \$15,000 higher annually than the existing system based on the cost of a 2-year comprehensive maintenance contract. The resulting net operating savings for NGEDAC technology is \$91,000 with the centrifugal unit operating and \$62,000 with the centrifugal unit off-line.

The preliminary estimate of the installed system cost for the gas technology is \$350,000 to \$400,000. This cost could vary up or down depending on specific installation conditions and desired equipment features. The preliminary capital cost estimates are based on system environmental emission limits of 2.60 gm/bhp/hr for NO_x and 1.75 gm/bhp/hr for CO. The total estimated project cost does not include any potential electrical demand reduction rebates for which this project may qualify.

Other potential cost issues to be investigated in the design phase include assessing the price of natural gas, addressing potential environmental issues that currently appear to be minimal, and finalizing the overall equipment requirements so price estimates can be formalized. Figure B1 shows the main air system operating costs.

The Watervliet site has a number of other positive aspects that help make it a good demonstration site. Gas supply is readily accessible, though it may be under-pressured. The Watervliet site provides for a fairly straightforward technology application. It affords the Department of Defense an excellent opportunity to test operating a "gas/electric hybrid system." In addition, the Arsenal would be provided an opportunity to gain experience in using one of the larger-sized units available with NGEDAC technology.

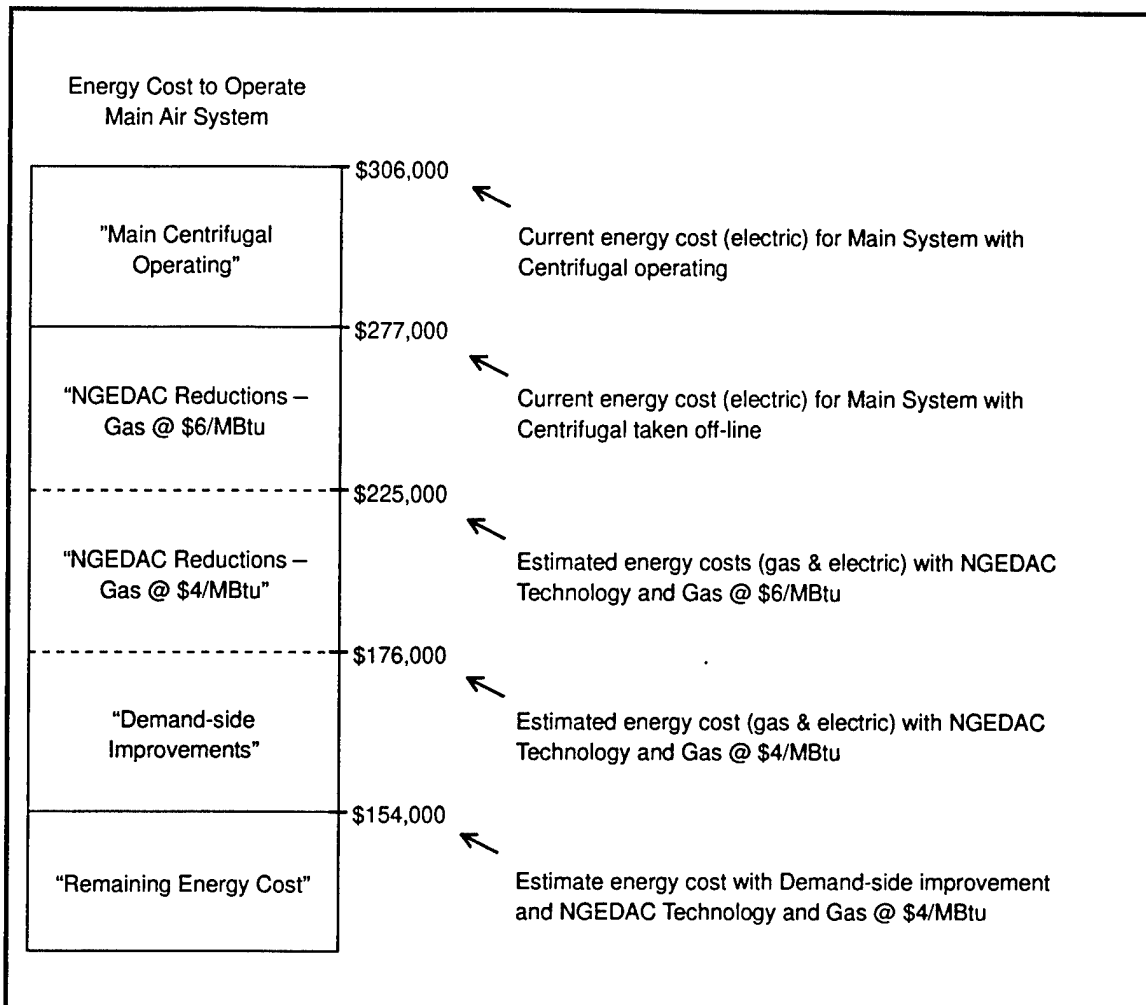

Figure B1. Main air system operating costs.

Section 1. Current System Review

Background

The Watervliet Arsenal has a very extensive compressed air system linking many separate buildings and spread over a large geographical area. The air system reaches most production sectors and runs building to building, eventually completing a full "loop" system. The compressed air supply is primarily generated in Building 110 with one large 2000 cfm (450 hp) class Joy centrifugal compressor and two 125-hp Ingersoll-Rand XLE (650 cfm per machine) reciprocating compressors.

There are six other major compressors tied in to the main air system in surrounding buildings. There are also a number of smaller air-cooled reciprocating

units throughout the Arsenal either as part of the separate "controls air system" or dedicated air to a particular process.

Air drying is provided by both desiccant and refrigeration units and appears to be working well according to plant personnel and survey results. Most of the compressors are water cooled, but some have their own air-cooled, radiator-type, closed-cooling systems, which also appear to be working well.

The complete air system appears to be very well laid out, well maintained and operated consistently with the type of controls on each compressor unit. However, on the demand side of the system, there are a number of areas that should be reviewed in the future in more detail, as they appear to be significant opportunities reducing air consumption.

The overall usage in the full system today is on the order of 2000 to 2500 cfm. In the past, when there was a higher level of production at the site, the overall usage was larger. The results of the preliminary site survey suggests there are leaks amounting to at least 300 cfm that could be identified and repaired, which would reduce annual electric costs by over \$22,000. There seem to be some tank agitation applications that could perhaps be powered by low-pressure air compressors or blowers rather than costly high-pressure air. These and other demand-side savings opportunities will be enumerated in the Level II Assessment if Watervliet Arsenal is selected as a NGEDAC demonstration site.

Current and Reconfigured System Baseline

The key characteristics describing the performance and economics of the current and proposed compressed air system are summarized in Tables B1, B2 and B3. The table was developed based on the data collected during the site visit and in discussions with plant personnel. The proposed system estimates are technically and economically conservative and reflect the observed performance of each compressor compared to load cycle.

Observations of Plant Personnel

At current load, the Joy centrifugal 450-hp will "carry the plant" with some assistance from the IR LLE-5 (Building 25), which provides on the order of 100 cfm for several hours a day. Usage levels for the second and third shifts do not seem to fall much, probably due to high use of aeration air, vortex cooling, leaks, etc., which occur 24-hours per day. The estimated average system flow is approximately 2000 to 2500 acfm.

Table B1. Surveyed air compressor performance characteristics.

Bldg	Unit	FL kW	FL acfm	% Load	Net cfm	Net kW
25	IR LLE-5	100.80	653	75%	490	80.64
20	ED 100	11.79	446	85%	379	74.68
35	(3) WN112	<< Off >>	—	—	—	—
110	XLE-2	100.51	687	100%	687	100.51
110	Joy TA18	<< Off >>	—	—	—	—
110	XLE-2	100.51	687	90%	618	95.48
125	WN112	<< Off >>	—	—	—	—
Total					2,174	351.31

Table B2. Estimated air compressor performance characteristics.

Bldg.	Unit ¹	FL kW	FL acfm	% Load	Net cfm	Net kW
25	IR LLE-5	100.80	653	27%	174	35.28
110	Joy TA18	353.37	2,000	100%	2,000	353.37
Total					2,174	388.65

¹Assumes all other units off.

Observations of Audit Team

The main air supply was on and running during the plant survey period from 10:30 am to 1:00 pm on 31 October 2000. The system supply pressure was observed in the operating range of 83 to 85 psig. The pressure at the compressors was observed in the operating range of 90 to 100 psig. In most cases, the centrifugal unit is operated at full load. However, on the day of the visit, the centrifugal unit was not operating.

The blended electric rate equals \$0.09/kWh. Average annual electric rates at the plant are \$0.09/kWh. The actual plant electric cost for air production, as currently operated, is in excess of \$300,000 per year. The load profile or demand of this system is relatively stable during all shifts. The full load operating range is 24 hours a day, 365 days a year, for 8760 hours a year. The system pressure appears to operate in the range of 83 to 85 psig at the headers during production periods. There are no flow meters in the system.

The standard performance measure used for this analysis is "electric cost per hour per loaded cfm" of air. Annual electric cost was selected as the key project evaluation factor, since it is a good overall indication of system costs and savings associated with potential measures. It is a quantitative number and not a subjective opinion, i.e., if the compressed air is used, these dollars are spent.

Table B3. Estimated energy costs — current and proposed systems (all shifts).

Performance Measure	Current Systems		Proposed NGED ¹ System	
	Oct 31, 2000	Typical Day	Electric	Natural Gas
Average air flow (cfm)	2,174	2,174	674	1,500
Input power (kW)	351.31	388.65	100	NA
Operating hours	8,760	8,760	8,760	8,760
Specific power (cfm/kW)	6.18	5.56	6.74	NA
Annual energy cost for air (\$/cfm/yr)	\$127.57	\$141.79	\$116.97	\$65.08 @ \$4/MCF \$97.63 @ \$6/MCF
Annual energy cost for air (\$/yr)	\$276,972	\$306,411	\$78,840	\$97,630 @ \$4/MCF \$146,445 @ \$6/MCF
¹ Proposed system includes 1,500 cfm natural gas engine drive and one existing IR 125 hp XLE operating at full load. Natural gas system parameters include 8,170 Btu/hp-hr, 341 BHP and 8,760 hours annually.				
Total				2,174

All paybacks are estimated using "Full Load Operating Efficiencies," which are very conservative. If the compressed air is not used, the compressor either shuts off or unloads. If it shuts off, there is a 100 percent saving of the electric cost. If it unloads, there is a 25 to 90 percent savings of the electric cost.

It is important to note that other recoverable compressed air costs should also be considered, e.g., maintenance, cooling water costs, and depreciation. Usually, the electricity cost is between 75 and 90 percent of the total "variable compressed air costs." Associated maintenance and other costs will be, in all probability, at least 20 percent or more of the identified electric cost. Existing plant records may already have these identified.

Energy Cost Baseline

Table B4 lists recent history of energy expenditures at Watervliet Arsenal.

Gas costs averaged \$4.21 per million Btu in Fiscal Year 1999. This average was up about 10 percent over Fiscal Year 1998 and by about 20 percent over Fiscal Year 1997. These gas prices include \$0.60 per million Btu transportation costs. An estimate of \$5 per million Btu was used as the baseline for this assessment with \$4 and \$6 per million Btu used as a sensitivity analysis. A \$1 increase in gas price increases operating costs by about \$25,000 for the NGEDAC.

Table B4. Energy cost summary.

Month	Electric			Natural Gas		
	Use (kWh)	Cost (\$)	Rate (\$/kWh)	Use (MMBtu)	Cost (\$)	Rate (\$/MMBtu)
FY-97	32,240,516	2,751,330	0.0853	32,963	116,433	3.5322
FY-98	31,404,550	2,322,902	0.0740	24,611	97,380	3.9568
Oct-99	2,573,874	185,904	0.0722	15,100	57,609	3.8152
Nov-99	2,363,428	179,699	0.0760	23,690	108,690	4.5880
Dec-99	2,430,821	178,911	0.0736	34,303	119,123	3.4727
Jan-00	2,705,661	213,373	0.0789	20,593	77,053	3.7417
Feb-00	2,417,303	183,645	0.0760	43,095	177,984	4.1300
Mar-00	2,501,397	191,840	0.0767	27,822	111,626	4.0121
Apr-00	2,344,946	193,010	0.0823	10,389	43,444	4.1817
May-00	2,557,299	216,039	0.0845	3,862	31,089	8.0500
Jun-00	2,646,735	273,949	0.1035	0	1,014	0.0000
Jul-00	2,371,271	212,614	0.0897	0	1,014	0.0000
Aug-00	2,938,037	275,736	0.0939	0	23,350	0.0000
Sep-00	2,503,698	218,487	0.0873	29	1,921	66.2414
FY-99	30,354,470	2,523,207	0.0831	178,883	753,917	4.2146

Electric costs averaged \$0.83 per kWh during Fiscal Year 1999. At the end of December 2000, a special contract that Watervliet had with NIMO expired. The net impact of this change will be an increase to \$0.09 per kWh as the average rate for Watervliet in moving forward. This level of impact was provided by Watervliet staff and confirmed by project staff. The value of \$0.09 per kWh was used in the project assessment.

Section 2. Supply-Side System Review

Primary Air Compressor Supply

The following is an overview of the compressed air supply system as observed on 31 October 2000.

Building 110

Units 110N and 110S are each 125-hp class Ingersoll Rand, two-stage, water-cooled, double-acting reciprocating XLE compressors. They are also of a continuous duty design. These are the most power-efficient air compressors at full load and when at part load to meet varying demand. They appear to be in good operating condition, although the inspection team did not perform any tear down inspection. There is no reason from a power efficiency standpoint to replace these units.

Unit 110 Center is a 450-hp Joy three-stage centrifugal (oil-free) TA18 compressor delivering 1850 to 2000 acfm at 100 psig at 450 bhp. This is a dynamic compressor, and actual air delivered and performance will vary with operating conditions. From a full load power efficiency standpoint, the TA18 is about the same as the XLE. However, the TA18 does not unload or meet part load demands as efficiently in "turndown" much below 25 percent when operating correctly. This unit is very power efficient from about 2000 to 1500 acfm flow. This TA18 is equipped with inlet guide vanes (IGVs), which allow almost "perfect turndown" from 2000 to 1500 acfm load. At flows below 1750, it will be less efficient, and at lower loads it will be very inefficient with the current installed control system. Other than a more efficient unloading central controller, there is no reason from a power standpoint to replace or modify this unit.

Because of its central location on the system, proximity to other compressor units, available physical space, and easy access to gas, Building 110 is the leading candidate as the site for the proposed NGEDAC system. Preferred location is probably along the south wall of building.

Building 125

Building 125 houses a Joy WN112 75-hp two-stage, double-acting, water-cooled compressor delivering 405 acfm at 100 psig at 77.3 bhp. This unit also appears to be in excellent shape and, according to plant personnel, runs very well. Even though it is an older unit (circa 1956), it is of the best designs for its type. There is no reason from a power efficiency or application standpoint that it should have to be replaced.

Building 35

Building 35 has three Joy WN112 compressors, the same as described above. One unit is a 75-hp (405 acfm @ 100 psig) and the other two are 100-hp (564 acfm @ 100psig). They all appear to be in good working order and well maintained.

Building 25

Building 25 houses a 125-hp Ingersoll Rand LLE-5 two-stage, double-acting, water-cooled compressor delivering 653 acfm @ 100 psig @ 125 bhp. This is the newest of the double-acting, water-cooled units and is of "leading edge technology." Key characteristics of this "balanced drive" include:

- Extra large valve area—shorter lift—cooler running
- Large cooling jackets
- Built-in high performance intercooler and aftercooler.

As in the case of the rest of the double-acting units, the unit runs well and appears to be in good shape, and is very well maintained. There is no reason to replace this unit based on power efficiency. As in the case of the other compressors, it is continuous duty rated.

Building 20

Building 20 has a new Ingersoll Rand EP100 single-stage, lubricant-cooled, rotary screw air compressor. This unit is air cooled, but it is also continuous duty. The EP100 is obviously state-of-the-art and very conservatively applied. Its 100-hp motor is designed to run with a 1.15 service factor and the basic unit delivers 446 acfm at 125 to 135 psig at full load. It has been applied in the system very professionally with an operating band of 90 to 100 psig. This puts a load of 96.25 bhp or less on the 115-hp rated motor. It should do very well in the long run and, of course, save energy.

General Comments on the Air System

1. The above listed units are the main or primary air compressors used to support manufacturing and test operations at Watervliet. All but one (a rotary screw) are water-cooled units and each unit has its own polyglycol closed-cooling system. This utilization of available equipment is an excellent operational strategy and appears to be working well. This type of operation eliminates many of the problems associated with water-cooled units. The 450-hp Joy centrifugal has a closed-radiator-type system also, and according to plant personnel, it works well except for several hours a day during extremely hot weather ($>90^{\circ}\text{F}$). To alleviate this problem, there is a manually operated spray line set up to super cool when necessary. Centrifugal and rotary screws are more sensitive to cooling conditions in both useful life and performance than industrial reciprocating units. The sprayer is currently working. In the future, some consideration could be given to an automatically controlled high-performance secondary inline cooler between the radiator discharge and the compressor water inlet.
2. Buildings 133 and 40 have are some Worthington M-Line, single-acting, air-cooled reciprocating units which are not operating under continuous duty. These type units are not well suited to industrial production applications. They are rated very low in power efficiency. One of these is inoperable now; these units should be kept only for emergency backup air, if at all.
3. In addition to these 50- and 100-hp air-cooled units, there are at least nine 25-hp air-cooled Ingersoll Rand compressors in Building 15; one 15-hp air-cooled Wayne compressor in Building 120; and one 25-hp Champion (Speedair) compressor in Building 120. These types of units are well applied at or near the point of end-use production, particularly where higher than the 85 psig systems pressure is needed, to feed an intermittent demand. They are not continuous duty and should be applied on about a 50 percent duty cycle for normal life, operating, and maintenance costs. They are not particularly power efficient and should not be run in place of general system units unless higher pressure is required.
4. Well over 20, 5-hp and smaller air-cooled reciprocating compressors are set up on appropriately sized horizontal air receivers and refrigerated air dryers throughout the Arsenal. Most of these are not part of the control system and are separate from the main system air. Where a 5-hp or fractional-hp unit is run instead of the general air system, utilization of these units should be questioned unless it is for higher air pressure than the main system. These units are not even close in power efficiency performance to the main air system units.
5. There is also a Breathing Aid compressor and system in Building 110 South and 123 for painting processes. These are well applied and only used when painting is in progress.

6. All units have their own local capacity control system and all, except the 450-hp Joy centrifugal, are set up to start automatically when air is needed and to shut off automatically when not needed. This control strategy appears to work very well and is a very positive step in air conservation already taken.

The primary compressed air supply is produced by relatively efficient air compressors that are capable of delivering the 100 psig full load pressure continuously. The units are well applied. They appear to be in good operating order and well maintained. Table B5 lists key characteristics of the units.

Compressor Capacity Controls

The two most effective ways to run air compressors are at "Full Load" and "Off." Capacity controls are a means of restricting the output cfm delivered to the system while the unit is still running. This is always a compromise and it is never as efficient as full load on a specific power (cfm/bhp) basis.

Controls for Reciprocating Compressors

Reciprocating compressors are double-acting, water-cooled units with multi-step unloading. This is an efficient compressed air unloading system. Reciprocating multi-step unloading will efficiently translate percentage of "less air used" into almost the same proportional reduction in energy cost.

Table B5. Key performance characteristics by compressor type.

Performance Characteristics	Double Acting Recip (2 units)	Centrifugal (1 unit)	Double Acting Recip (2 units)	Double Acting Recip (2 units)	Double Acting Recip (1 unit)	Single-stage Rotary Screw (1 unit)
Brand	IR	Joy	Joy	Joy	IR	IR
Model	XLE	TA18	WN112	WN112	LLE-5	EP100
Air Capacity (acfm)	687	2,000	564	405	653	446
FL Press	100	100	100	100	100	100
FL kW @ 100 psig	100.51	353.37	88.69	64.79	100.8	77.79
Cfm/kW/100 psig	6.83	5.66*	6.36	6.25	6.48	5.73
Annual Electric Cost (\$/cfm)	\$115.43	\$139.29	\$123.92	\$126.14	\$121.66	\$137.59
Annual Electric Cost (\$/psig)	\$396.25	NA	\$349.61	\$255.41	\$397.35	\$306.64

For more precise performance measures, see OEM curve or measure actual flow and input kW – compare in scfm, unit was down for repairs during the site visit. Data were obtained from plant personnel. Blended electric rate equals \$0.09/kWh.

The current system has two-step, free air unloading on the Ingersoll Rands and two-step total closure on the Joys. They are very responsive and power efficient. There are also newer electronic Intelysis controls on the IRs.

Controls for Rotary Screw Compressors

The two most common controls used rotary screw compressors are modulation and online/offline. Modulation is relatively efficient at very high loads—and inefficient at lower loads. Online/offline controls are very efficient for loads below 60 percent, when properly applied with adequate time for blow down. There are several other control types (e.g., “rotor length adjustment” or “variable displacement” and “variable speed drive”) that have very efficient turndown from 100 percent load to about 60 percent load.

These controls must be installed correctly to operate efficiently. Piping and storage should be available close to the unit with no measurable pressure loss at full load to allow the signal to closely match the air requirements.

The current system has online/offline controls with an automatic electronic upper range modulator on the new IR rotary screw. It is very well applied and installed and appears to be working well.

Controls for Centrifugal Compressors

The two most common controls used for centrifugal compressors are modulation and blow off. Modulation is relatively efficient at very high loads, but will not work much below 75 percent load. After modulation or turndown, the compressor then just blows off excess air. The basic power draw at the blow off point then stays the same regardless of the load. The Watervliet unit uses these types of controls, and also uses IGVs to allow efficient turndown.

Today's modern electronic control systems can be applied to effectively close off the inlet and blow the unit down to idle, significantly reducing the kW draw. The Quad II control system installed now is somewhat limited, but the new Quad 2000 by Cooper (Joy) would do this with some system storage and piping modification. There is no reason to pursue this as long as the unit stays in base load and does go into continuing blow off.

The centrifugal units involved have capacity controls capable of translating “less air used” into a comparable reduction in electric cost. These controls will work effectively with current piping and the air receiver storage situation at today's conditions.

Long-Term Recommendation

With the system stabilized and balanced and with the primary air supply centrally located, consider a microprocessor-driven, centralized, full networking electronic control system. This will automatically place the most efficient machine online and assure use of no more than one partial loaded unit at a time. It will operate at a fixed system target pressure.

Air Treatment and Air Quality

Aftercoolers

Aftercoolers are mostly water cooled and appear capable of delivering 100 °F or lower temperature compressed air to the dryer during all seasons. The new rotary screw unit has a high performance air-cooled aftercooler.

Dryers

Refrigerated dryers require a refrigeration system to mechanically cool the air. The lowest possible consistent pressure dew point with a noncycling dryer is +40 °F. Cycling and variable speed-driven dryers not only save power (60 to 75 percent), but also can deliver a lower pressure dew point (down to 35 to 38 °F) when:

- air is delivered to the dryer at no more than 100 °F
- the condensate driven out of the aftercooler, prefilter, dryer and afterfilter is immediately removed from the system and not allowed to re-entrain or build up
- the dryer is not overloaded in volume (scfm).

Desiccant dryer regeneration equipment removes moisture vapor by “adsorbing” it to desiccant beads. These dryers can consistently deliver a pressure dew point to -40 °F or lower, which removes much more water than conventional refrigeration units. To regenerate the wet tower while the other tower is drying requires the use of heat in some form and some dry air to “sweep” or “purge” the exchanged moisture out. Desiccant dryers are usually rated at the same 100 °F inlet, 100 psig conditions. They also require:

- that air is delivered to the dryer at no more than 100 °F
- that the condensate driven out of the aftercooler, pre-filter, dryer and after-filter is immediately removed from the system and not allowed to retrain or build up.

The current system has a refrigerated dryer on most of the air compressors, and they all appeared to be well applied and maintained. Those that were in use were running well. There are also two heatless, twin-tower regenerative dryers (670, 730 scfm each), which deliver dryer air to specific areas. These are also relatively well applied and, even though they use 15 percent purge air, they are equipped with new point removal purge controllers, which will usually reduce this by about 50 percent.

The centrifugal goes through a 2500 scfm rated Van Air internally heated twin-tower regenerative dryer, which is the most energy efficient type of dryer available except heat of compressors. It takes less intensive energy because of induction compared to the condition heating of the bead with other types and uses much less purge air. It is also equipped with a dew point demand purge controller.

Water or Oil Carryover in System

Water (condensate) and oil carryover problems in the current air system are not significant. The correct way to eliminate water and oil in the air system is to clean and dry the air immediately after it is produced in the compressor room. Then, clean dry air can be stored in a separate air receiver and delivered to the system, as required. Some guidelines for controlling oil and water carryover include:

1. Generally, it is best to eliminate the water and oil at the air source before it enters the air system.
2. Every 20 °F increase in temperature doubles the "moisture load" the compressed air will hold.
3. Compressed air dryers are usually capacity rated with 100 °F, 100 psig inlet air conditions. At 120 °F, 100 psig, the dryer's capacity rating is reduced 50 percent.
4. Putting "dry or oil free" air into the system 90 percent of the time and then allowing wet or oily air in sporadically 10 percent of the time will, in reality, make the system wet or oily all the time. The liquid water or oil will fall out in the piping system continuing to "re-entrain" and contaminate or collect in the "low spots" of the system, thus causing recontamination as air is pulled into the flowing compressed air system. A wet or oily system may well take many months of continuous flowing of clean dry air to "clean up."
5. Identify required pressure and dew point.

Pre-Filters and After-Filters

Pre- and after-filters are generally either particulate or coalescing type, and their use depends on the type of dryer being used and various installation considerations.

Desiccant dryers always require a high-quality coalescing pre-filter to keep liquid oil and water out of the drying tower. They also always require an effective particulate filter after the dryer to keep "desiccant dust" from migrating into the system.

Refrigerated dryers may or may not need pre- and after-filters depending on the piping, type of compressor, and desired degree of cleanliness. If the inlet air is apt to be dirty and fouled with carbon scale, etc., a particulate pre-filter is required. If the inlet air is liable to have significant liquid or heavy oil mist, a coalescing (or combination coalescing particulate) pre-filter may be needed. If oil or water mist is leaving the dryer, a coalescing after-filter may be in order.

Care in selection must be taken in all cases because:

- Wasted air pressure costs energy dollars.
- Wasted air pressure neutralizes the operating pressure band early.
- Standard coalescers will usually not perform effectively at flows much below 20 percent of their rated capacity.
- Standard coalescers life will be significantly shortened by particulate load
- Loose-packed, deep-bed mist eliminators (those with correct elements) will coalesce effectively throughout the total scfm range.
- Loose-packed, deep-bed mist eliminators (those with correct elements) have very high particulate load capability.

The pre- and after-filter(s) in this system are well applied and apparently well maintained.

Automatic Condensate Drains

The configuration and performance of condensate drains in the plant's system do not need to be modified. However, there still are some dual-timer drains that should ultimately be replaced with level-actuated ones.

Demand-Side System Review

It is the job of the main header system to deliver compressed air for production use from the compressor area to all sectors of the plant with little or no pressure

loss—with 1 to 2 psig being a reasonable target. It is also desirable that the compressed air velocity in the main headers be kept below 20 fps to allow effective dropout of contaminants and to minimize pressure losses caused by excessive turbulence. The magnitude of the turbulence effect also depends on piping design and layout.

Basic System Header and Piping

Headers were checked at appropriate points with a single test gauge and there is a pressure loss of approximately 1 psig or less in the header systems. This indicates that the header system today can deliver the required air to any area without any significant pressure loss. Low-pressure problems encountered may be in the feeds from the header to the area.

Minimum Effective System Pressure

The system is currently running at 83 to 85 psig. However, there are additional direct power cost savings that will accrue from continuing to lower the overall system operating pressure. A steady delivered pressure to the system will allow follow-up programs at each process to establish the lowest effective pressure. This will enhance productivity, quality, and continue to reduce air usage.

The cornerstone of any effective demand-side air conservation program is to identify and operate at the lowest acceptable operating pressure at various sectors and operating units in the plant. This conservation program should be a part of any training, operating, and maintenance procedures.

Check Regulator

Some regulators are probably set at higher feed pressures than necessary for the process, with some regulators set for wide open to full header pressure. Arsenal personnel should always keep certain questions in mind. Is there a minimum effective pressure at operation established at the unit for each product run? If so, is it being adhered to?

In this type of operation, it is very important that the actual inlet pressure to the process be known and that the lowest effective pressure be held steady for the proper product quality. Installation of storage bottles downstream of the regulator may be needed to "close up" the pressure readings at rest and at operation.

Recommended Investigation

Determine whether regulators and regulated flow at process can be modified to reduce overall system pressure.

Compressed Air Condensate Handling

Reviewing the condensate handling system, we understand that the condensate goes to water treatment. If this is true, and discharge condensate meets the requirements of the water treatment facility plant, there is no problem. However, if condensate is discharging to a storm sewer or in some other manner to ground water (Federal EPA minimum is 10 ppm), or is required to be separated it by the local water treatment facility, this practice should be investigated in detail.

Recommended Investigation

Review compressed air condensate handling system to ensure compliance with environmental regulations.

Leak Identification And Repair

With a plant of this type, an effective leak control program could save 300 cfm or the equivalent of repairing 100 leaks averaging 3 cfm each. On a percentage basis, this leak level is then about the same as leak levels in other plants. A leak level of 300 cfm translates into an annual loss of \$30,000 in electric cost, at \$100/cfm. A comprehensive leak management program could reduce such levels by 75 percent, saving up to \$22,000 annually.

Recommended Investigation

Consider implementing a continuing leak identification and repair program with ultrasonic locators.

There should be a continuing cost minimization program in place. Generally speaking, the most effective programs are those that involve the production supervisors and operators working positively with the maintenance personnel. Accordingly, it is suggested that the program consist of the following:

Short Term

Set up a continuing leak inspection by maintenance personnel so that for a while, each primary sector of the plant is inspected once a quarter, or at a mini-

mum, once every 6 months, to identify and repair leaks. A record should be kept of the findings and overall results.

Long Term

Consider setting up programs where the production people (particularly the operators and their supervisors) are positively motivated to identify and repair leaks. One method that has worked well with other operations is to monitor the airflow to each responsible section (perhaps with the use of recording the nonrecording flow meters) and to identify the air usage as a measurable part of the operating expense of that area. This usually works best when combined with an effective in-house training and awareness program. Table B6 lists costs and savings associated with implementing a leak management program.

Automatic Ball Valves

Some of the most significant areas for leaks in any high-production plant involve shutting off the air supply to machinery when not in use. When these opportunities are found, there are usually some very economical and easy methods to automatically shut off machinery air supply when not in use.

Cabinet Coolers

Cabinet cooling is often required to obtain reasonable life and performance of the electronic equipment in control cabinets. There are various means of accomplishing this cooling: blowing compressed air into the cabinet, and by using vortex coolers, refrigeration units, or heat tube cabinet coolers. Blowing straight compressed air into the cabinet is generally very inefficient.

Table B6. Costs and savings associated with implementing a leak management program.

	Parameter	Cost / Savings
Costs	Leak detection equipment	\$2,800
	Leak program development and detection equipment training	\$1,000
	Leak repair (100 leaks @ \$30 materials per leak and \$50 labor per leak)	\$3,000
Savings	Calculated electric savings from leak program	\$22,000 per year
	Estimated number of leaks	100 leaks
	Estimated average leak size	3 cfm per leak
	Estimated leak level	300 cfm
	Potential value of leak reduction	\$100 per cfm
	Estimated unit electric savings	\$30,000 per year
	Recoverable leak losses	75%
	Total Program Cost	\$5,000 plus \$1,000 annually for ongoing repairs

Vortex coolers can use chilled air with no moving parts and use less air. Vortex coolers should always:

- be regulated to the lowest effective pressure
- be equipped with the lowest possible flow generator
- be equipped with automatic temperature controlled shutoffs.

Refrigeration units should be carefully selected and equipped with automatic regulation control. Heat tubes are the most energy efficient when applied and can cool a "sealed cabinet." There are some cabinet coolers in use in the plant. These may all be replaced with "heat tube" cabinet coolers with a potential savings of 3.5 to 4 kW each.

CERL Distribution

Chief of Engineers
ATTN: CEHEC-IM-LH (2)

Engineer Research and Development Center (Libraries)
ATTN: ERDC, Vicksburg, MS
ATTN: Cold Regions Research, Hanover, NH
ATTN: Topographic Engineering Center, Alexandria, VA

Army Materiel Command (AMC)
Installations (41)

Defense Tech Info Center 22304
ATTN: DTIC-O

50
8/01

