

## INTERNET DOCUMENT INFORMATION FORM

**A. Report Title: Best Manufacturing Practices: Report of Survey  
Conducted at Orenda Turbines, Division of Magellan, Aerospace  
Corporation, Mississauga, Ontario, Canada**

**B. DATE Report Downloaded From the Internet: 12/20/01**

**C. Report's Point of Contact: (Name, Organization, Address, Office  
Symbol, & Ph #): Best Manufacturing Practices  
Center of Excellence  
College Park, MD**

**D. Currently Applicable Classification Level: Unclassified**

**E. Distribution Statement A: Approved for Public Release**

**F. The foregoing information was compiled and provided by:  
DTIC-OCA, Initials: \_\_VM\_\_ Preparation Date 12/20/01**

The foregoing information should exactly correspond to the Title, Report Number, and the Date on the accompanying report document. If there are mismatches, or other questions, contact the above OCA Representative for resolution.



REPORT OF SURVEY CONDUCTED AT  
**ORENDA TURBINES,  
DIVISION OF MAGELLAN  
AEROSPACE CORPORATION  
MISSISSAUGA, ONTARIO, CANADA**  
OCTOBER 1999



## *Best Manufacturing Practices*

1998 Award Winner



INNOVATIONS IN AMERICAN GOVERNMENT

**BEST MANUFACTURING PRACTICES CENTER OF EXCELLENCE**  
College Park, Maryland  
[www.bmpcoe.org](http://www.bmpcoe.org)

20011231 056

AR02-03-0573

# Foreword

---



This report was produced by the Office of Naval Research's Best Manufacturing Practices (BMP) program, a unique industry and government cooperative technology transfer effort that improves the competitiveness of America's industrial base both here and abroad. Our main goal at BMP is to increase the quality, reliability, and maintainability of goods produced by American firms. The primary objective toward this goal is simple: to identify best practices, document them, and then encourage industry and government to share information about them.

The BMP program set out in 1985 to help businesses by identifying, researching, and promoting exceptional manufacturing practices, methods, and procedures in design, test, production, facilities, logistics, and management – all areas which are highlighted in the Department of Defense's 4245.7-M, *Transition from Development to Production* manual. By fostering the sharing of information across industry lines, BMP has become a resource in helping companies identify their weak areas and examine how other companies have improved similar situations. This sharing of ideas allows companies to learn from others' attempts and to avoid costly and time-consuming duplication.

BMP identifies and documents best practices by conducting in-depth, voluntary surveys such as this one at Orenda Turbines, Division of Magellan Aerospace Corporation, Mississauga, Ontario, Canada conducted during the week of October 18, 1999. Teams of BMP experts work hand-in-hand on-site with the company to examine existing practices, uncover best practices, and identify areas for even better practices.

The final survey report, which details the findings, is distributed electronically and in hard copy to thousands of representatives from industry, government, and academia throughout the U.S. and Canada – *so the knowledge can be shared*. BMP also distributes this information through several interactive services which include CD-ROMs, BMPnet, and a World Wide Web Home Page located on the Internet at <http://www.bmpcoe.org>. The actual exchange of detailed data is between companies at their discretion.

Orenda Turbines is an established leader in power and propulsion technologies, and has more than 50 years of experience in developing, certifying, and manufacturing gas turbines. Continuing in its pioneering efforts, the company is striving to strengthen its competitiveness; advance its high standard of performance and dependability, and enrich its vision for the next century. Among the best examples were Orenda Turbines' accomplishments in firm pricing model for engineering support services; repair scheme development; F404 best build process; equipment condition monitoring system; and financial reporting tools.

The Best Manufacturing Practices program is committed to strengthening the U.S. industrial base. Survey findings in reports such as this one on Orenda Turbines expand BMP's contribution toward its goal of a stronger, more competitive, globally-minded, and environmentally-conscious American industrial program.

I encourage your participation and use of this unique resource.

A handwritten signature in cursive script, reading "Ernie Renner".

Ernie Renner  
Director, Best Manufacturing Practices

# Contents

Orenda Turbines, Division of Magellan Aerospace Corporation

---

## **1. Report Summary**

<b>Background</b> .....	<b>1</b>
<b>Best Practices</b> .....	<b>1</b>
<b>Information</b> .....	<b>3</b>
<b>Point of Contact</b> .....	<b>4</b>

---

## **2. Best Practices**

### **Test**

Engine Test Cell Data Acquisition .....	5
---	---

### **Production**

Advanced Repairs .....	5
Butler Newall High Speed Blade Tip Grinder .....	6
F404 Best Build Process .....	6
Moment Weight Measurement System.....	7
Repair Scheme Development .....	7
Travel Card Generator .....	8

### **Logistics**

Equipment Condition Monitoring System .....	9
---	---

### **Management**

Asset Management System .....	10
Corrective Action and Deviation Report Database Systems .....	11
Financial Reporting Tools .....	11
Firm Pricing Model for Engineering Support Services .....	12
Measures of Performance System .....	13
Work Cell Development .....	13

---

Contents (Continued)

Orenda Turbines, Division of Magellan Aerospace Corporation

---

**3. Information**

***Production***

BioFuel ..... 15  
Front Frame Strut Repair Process ..... 15  
Plasma Spraying ..... 15

***Facilities***

Co-Generation Project ..... 16

***Management***

Low Carbon Monoxide Liners for OT-3 Industrial Turbines ..... 16

---

***APPENDIX A - Table of Acronyms ..... A-1***  
***APPENDIX B - BMP Survey Team ..... B-1***  
***APPENDIX C - Critical Path Templates and BMP Templates ..... C-1***  
***APPENDIX D - BMPnet and the Program Manager's WorkStation ..... D-1***  
***APPENDIX E - Best Manufacturing Practices Satellite Centers ..... E-1***  
***APPENDIX F - Navy Manufacturing Technology Centers of Excellence ..... F-1***  
***APPENDIX G - Completed Surveys ..... G-1***

---

# Figures

Orenda Turbines, Division of Magellan Aerospace Corporation

---

## Figures

2-1	F404 Oil Tank Assembly .....	8
2-2	Equipment Condition Monitoring System LAN .....	9
2-3	Firm Pricing of Engineering Support .....	12

# Section 1

## Report Summary

---

### Background

Orenda Turbines can trace its ancestral line back to a Canadian crown corporation called Victory Aircraft, which produced the highly successful English Avro Lancaster bomber during World War II. Impressed with the performance of the Canadian facility, the English firm decided to set up another operation at this Malton, Ontario plant after the war. A. V. Roe Canada, as it was renamed, soon established itself and its subsidiaries, Avro Aircraft and Orenda Engines, as world leaders in aviation technology. Among their accomplishments were the Chinook, the first Canadian jet engine; the C-102 Avro Jetliner, the first jet transport to fly in North America; the Orenda jet engine, one of the most successful turbojet engines ever built; and the CF-100 Canuck, a long-range, high-altitude, all-weather interceptor. However, the group's most acclaimed project, the CF-105 Avro Arrow, is also famous for its mystery and legend.

Built on production tooling without a prototype, the Avro Arrow was a delta-winged, supersonic interceptor powered by Orenda's 30,000-pound thrust Iroquois engine. At three-quarter throttle, this state-of-the-art aircraft flew at nearly twice the speed of sound. Then in 1959, the project was terminated by the Canadian Government and all traces (e.g., aircraft, components, tooling, drawings, documentation) were ordered to be destroyed. Although the Arrow legend was founded on fact, the circumstances surrounding its cancellation and destruction have a number of dark corners and possible villains. Speculation claims that one of the aircraft escaped the cutters' torches, giving rise to the notion of a Phantom Arrow.

In 1996, Orenda Turbines became a part of Magellan Aerospace Corporation. As a diversified supplier of products and services to commercial/defense aircraft manufacturers worldwide, Magellan maintains facilities throughout the United States and Canada, and achieved \$426.9 million in revenues for 1998. Since 1946, Orenda Turbines has operated as the leading manufacturing and overhaul center for the Canadian Forces' high performance gas turbines. The company also built J79 and J85 engines under

license to General Electric; designed and manufactured the OT-2 and OT-5 series of heavy duty industrial gas turbines; and industrialized its Orenda-series flight engine. Located in Mississauga, Ontario, Orenda Turbines employs 185 personnel and achieved \$40 million in revenue for 1998. Among the best practices documented were Orenda Turbines' activities relating to engine hardware utilization exemplified by Repair Scheme Development and Advanced Repairs; software engineering development and support exemplified by the F404 Best Build Process, Equipment Condition Monitoring System, Asset Management System, and Test Cell Data Acquisition; and contract management functions exemplified by the Firm Pricing Model for Engineering Support Services and Financial Supporting Tools.

For more than half a century, Orenda Turbines' pioneering efforts have created a legacy of excellence and innovation. Even its name conveys this spirit as its translation from Iroquois is *the source of power*. Continuing in this tradition, Orenda Turbines is striving to strengthen its competitiveness; advance its high standard of performance and dependability, and enrich its vision for the next century. The BMP survey team considers the following practices to be among the best in industry and government.

### Best Practices

The following best practices were documented at Orenda Turbines:

Item	Page
<b>Engine Test Cell Data Acquisition</b>	<b>5</b>
Orenda Turbines upgraded its Engine Test Facility by incorporating a Digital Data Acquisition system. Using PC-based hardware and software, the company created a highly flexible test environment that can accommodate any foreseeable test situation. Almost all signal processing is handled by software and can easily be configured to simulate any combination of signal processing elements.	

Item	Page	Item	Page
<b>Advanced Repairs</b>	5	<b>Repair Scheme Development</b>	7
Orenda Turbines developed a Failure Modes and Effects Criticality Analysis-based system for determining certification requirements, and a design-approval process for certification. Millennium technologies are now being applied to engines which were designed 20 to 30 years ago. Among these are re-manufacturing parts to increase strength, developing sophisticated cost-benefit analysis, and employing state-of-the-art techniques (e.g., laser reverse machining; water jet cutting and coating stripping) during the repair process.		Orenda Turbines recognizes that it is more economical to repair a component, if possible, than to discard the defective part and replace it with a new component — even when the repairs are not covered by existing instructions. The company has demonstrated its Repair Scheme Development capability on numerous engine components, typically at a fraction of the cost of buying a new component.	
<b>Butler Newall High Speed Blade Tip Grinder</b>	6	<b>Travel Card Generator</b>	8
In 1987, the Canadian Forces asked Orenda Turbines to investigate ways of improving the accuracy of rotor tip radius measurements and producing a rounder and more consistently sized rotor. As a result of its investigation, Orenda Turbines purchased a Butler Newall High Speed Tip Grinder. Significant features of this machine include providing hardcopy readouts of all blade sizes; highlighting out-of-tolerance blade readings; achieving a repeatability accuracy of 0.0005 of an inch; and grinding rotor blades at a speed of 3,000 rpm.		Orenda Turbines overhauls and repairs a wide variety of engine components and parts, many of which require multiple repairs. In 1992, the company developed and implemented the Travel Card Generator which computerized the production of travel cards; eliminated redundant and inefficient operations; and optimized the routing of parts through the shop.	
<b>F404 Best Build Process</b>	6	<b>Equipment Condition Monitoring System</b>	9
Orenda Turbines developed the Best Build process by creating a computer-based process that took advantage of the company's Equipment Condition Monitoring System, an existing database used since the mid-1980s. The Best Build process matches individual components (based on remaining service life) from the rotor assemblies currently undergoing repairs. Each match is based on real-life data of the component's life cycle.		The Equipment Condition Monitoring System employs relational database technology with a complete suite of graphic user interface software tools for data entry, processing, and report generation. This life/maintenance tracking system captures and monitors the location, configuration, status, accumulated use, and service history of fielded turbine engines.	
<b>Moment Weight Measurement System</b>	7	<b>Asset Management System</b>	10
To properly balance a set of blades on a rotor, one must first measure the moment weight of each blade and then install the blades in a sequence which optimally distributes the weight over the rotor. In 1998, Orenda Turbines developed the Moment Weight Measurement system. This system eliminated tedious and manual steps which were prone to errors; reduced the cycle time for blade sequencing and installation by more than 50%; and produces an annual savings of about \$40,000.		Orenda Turbines repairs F404 exhaust frames for the Canadian Forces and the U.S. Navy. Per the Navy's contractual requirements, the company must have adequate control over the government-owned property while under its charge. In 1994, Orenda Turbines developed the Asset Management System, a Microsoft Access, LAN-based program which provides real-time tracking.	
		<b>Corrective Action and Deviation Report Database Systems</b>	11
		Orenda Turbines developed two database systems for managing, assigning, responding, validating, tracking, trending, and approving root cause and corrective actions. The Corrective Action Database addresses actions related to nonconformance from customer complaints, quality systems, and procedural issues. The Deviation Report Database addresses actions related to nonconforming products.	

<b>Item</b>	<b>Page</b>	<b>Information</b>										
<p><b>Financial Reporting Tools</b></p> <p>Orenda Turbines believes the ability to maximize profitability while containing customer costs depends more on the application of good, practical business sense by managers and employees, and less on high-tech, automated financial systems. In 1995, the Finance Department developed user-friendly tools and resources to assist managers and supervisors in managing their resources effectively and efficiently.</p>	11	<p>The following information items were documented at Orenda Turbines:</p>										
<p><b>Firm Pricing Model for Engineering Support Services</b></p> <p>Orenda Turbines implemented a Firm Pricing Model for Engineering Support Services as a way to increase its competitiveness and decrease the customer's costs. This system enables the company to negotiate the Engineering Support Services contract using a fixed-price model, whereby gains resulting from efficiency improvements are shared by Orenda Turbines and the customer.</p>	12	<table border="0" style="width: 100%;"> <thead> <tr> <th style="text-align: center;"><b>Item</b></th> <th style="text-align: right;"><b>Page</b></th> </tr> </thead> <tbody> <tr> <td style="vertical-align: top;"> <p><b>BioFuel</b></p> <p>There has been an increased worldwide emphasis on fossil fuel usage reductions. As a result, Orenda Turbines is developing technologies for a gas turbine engine/generator/steam plant that runs on liquid BioFuel. This fuel can be made from wood, wood residues, straw, grasses, bagasse, cane trash, lignin, cellulose, agricultural residues, palm shells, and/or waste paper.</p> </td> <td style="vertical-align: top; text-align: right;">15</td> </tr> <tr> <td style="vertical-align: top;"> <p><b>Front Frame Strut Repair Process</b></p> <p>Orenda Turbines began manufacturing front frame strut assemblies for the F404-GE-400 engine in the late 1980s. Because of its location on the engine, this assembly incurred a number of problems early in service. However, the company resolved the problems by developing the Front Frame Strut Repair process. Because of its expertise and successful repair history with this component, Orenda Turbines is now the sole-source provider for front frame strut replacement in the F404-GE-400 engine.</p> </td> <td style="vertical-align: top; text-align: right;">15</td> </tr> <tr> <td style="vertical-align: top;"> <p><b>Plasma Spraying</b></p> <p>Plasma spraying is a complex process that requires dedicated technical support to achieve consistent quality. In the past, thermal spray processes at Orenda Turbines were subcontracted to several off-site vendors in the U.S. and Canada. In 1996, the company purchased a Miller 4500 Robotic Spray system, and now performs all in-house coating and evaluations of the process.</p> </td> <td style="vertical-align: top; text-align: right;">15</td> </tr> <tr> <td style="vertical-align: top;"> <p><b>Co-Generation Project</b></p> <p>Orenda Turbines has years of experience as a supplier and service provider of industrial gas turbine engines. Through a cooperative agreement, Orenda Turbines is combining this expertise with that of its strategic partners, Ukraine-based gas turbine design and manufacturing companies SPE Mashproekt and PA Zorya, to address the needs of a rapidly developing market for independent power production. The Co-Generation Project involves the development of an electricity/heat co-generation system based on the GT2500 industrial gas turbine engine.</p> </td> <td style="vertical-align: top; text-align: right;">16</td> </tr> </tbody> </table>	<b>Item</b>	<b>Page</b>	<p><b>BioFuel</b></p> <p>There has been an increased worldwide emphasis on fossil fuel usage reductions. As a result, Orenda Turbines is developing technologies for a gas turbine engine/generator/steam plant that runs on liquid BioFuel. This fuel can be made from wood, wood residues, straw, grasses, bagasse, cane trash, lignin, cellulose, agricultural residues, palm shells, and/or waste paper.</p>	15	<p><b>Front Frame Strut Repair Process</b></p> <p>Orenda Turbines began manufacturing front frame strut assemblies for the F404-GE-400 engine in the late 1980s. Because of its location on the engine, this assembly incurred a number of problems early in service. However, the company resolved the problems by developing the Front Frame Strut Repair process. Because of its expertise and successful repair history with this component, Orenda Turbines is now the sole-source provider for front frame strut replacement in the F404-GE-400 engine.</p>	15	<p><b>Plasma Spraying</b></p> <p>Plasma spraying is a complex process that requires dedicated technical support to achieve consistent quality. In the past, thermal spray processes at Orenda Turbines were subcontracted to several off-site vendors in the U.S. and Canada. In 1996, the company purchased a Miller 4500 Robotic Spray system, and now performs all in-house coating and evaluations of the process.</p>	15	<p><b>Co-Generation Project</b></p> <p>Orenda Turbines has years of experience as a supplier and service provider of industrial gas turbine engines. Through a cooperative agreement, Orenda Turbines is combining this expertise with that of its strategic partners, Ukraine-based gas turbine design and manufacturing companies SPE Mashproekt and PA Zorya, to address the needs of a rapidly developing market for independent power production. The Co-Generation Project involves the development of an electricity/heat co-generation system based on the GT2500 industrial gas turbine engine.</p>	16
<b>Item</b>	<b>Page</b>											
<p><b>BioFuel</b></p> <p>There has been an increased worldwide emphasis on fossil fuel usage reductions. As a result, Orenda Turbines is developing technologies for a gas turbine engine/generator/steam plant that runs on liquid BioFuel. This fuel can be made from wood, wood residues, straw, grasses, bagasse, cane trash, lignin, cellulose, agricultural residues, palm shells, and/or waste paper.</p>	15											
<p><b>Front Frame Strut Repair Process</b></p> <p>Orenda Turbines began manufacturing front frame strut assemblies for the F404-GE-400 engine in the late 1980s. Because of its location on the engine, this assembly incurred a number of problems early in service. However, the company resolved the problems by developing the Front Frame Strut Repair process. Because of its expertise and successful repair history with this component, Orenda Turbines is now the sole-source provider for front frame strut replacement in the F404-GE-400 engine.</p>	15											
<p><b>Plasma Spraying</b></p> <p>Plasma spraying is a complex process that requires dedicated technical support to achieve consistent quality. In the past, thermal spray processes at Orenda Turbines were subcontracted to several off-site vendors in the U.S. and Canada. In 1996, the company purchased a Miller 4500 Robotic Spray system, and now performs all in-house coating and evaluations of the process.</p>	15											
<p><b>Co-Generation Project</b></p> <p>Orenda Turbines has years of experience as a supplier and service provider of industrial gas turbine engines. Through a cooperative agreement, Orenda Turbines is combining this expertise with that of its strategic partners, Ukraine-based gas turbine design and manufacturing companies SPE Mashproekt and PA Zorya, to address the needs of a rapidly developing market for independent power production. The Co-Generation Project involves the development of an electricity/heat co-generation system based on the GT2500 industrial gas turbine engine.</p>	16											
<p><b>Measures of Performance System</b></p> <p>In 1996, Orenda Turbines developed the Measures of Performance system, which has evolved into a reliable and effective tool for improving the company's business. This Microsoft Access, LAN-based program provides weekly performance measurements pertaining to turnaround times, cycle times, subcontractor turnaround times, reworks, and work-in-process levels. The key to developing these indicators was to focus on a few measurable factors which would have the greatest effect on customer services.</p>	13											
<p><b>Work Cell Development</b></p> <p>Encouraged by the prospect of winning a major U.S. Navy contract in 1994, Orenda Turbines developed a manufacturing Work Cell capability which dramatically improved its repair and overhaul operations for F404 exhaust frame assemblies. As a result of its efforts, the company significantly reduced its repair and turnaround times, and won the contract.</p>	13											

---

Item	Page	<i>Point of Contact</i>
<b>Low Carbon Monoxide Liners for OT-3 Industrial Turbines</b>	17	For further information on items in this report, please contact:
<p>British Gas is one of Orenda Turbines' customers that uses OT-3 turbine powered gas compression packages. In 1998, this company was faced with tougher emission limits for its gas compression facilities. Working with a strategic partner, SPE Mashproekt, Orenda Turbines redesigned, manufactured, and installed new liners which significantly reduced the customer's emission level by a factor of eight to ten.</p>		<p>Mr. Ches Tacchi  Magellan Orenda Turbines  3160 Derry Road East  Mississauga, Ontario, Canada L4T 1A9  Phone: (905) 673-3250 x3221  Fax: (905) 673- 4045  E-mail: ctacchi@orenda.com  Web: <a href="http://www.orenda.com">http://www.orenda.com</a></p>

---

## Section 2

### *Best Practices*

---

#### *Test*

##### Engine Test Cell Data Acquisition

Prior to upgrading its Engine Test Facility, Orenda Turbines primarily used analog instrumentation and manually logged engine data into the system. Measurement accuracy and consistency were highly dependent on an operator's training, capability, and fatigue level. Likewise, the monitoring of engine deviations was affected by operator awareness and response. Converting test data to standard day conditions or other data processing tasks required extensive manual calculations, plotting, and comparison to test specifications. Additionally, the analog test equipment became increasingly difficult and costly to support. To improve the accuracy, productivity, and maintainability of its operations, Orenda Turbines replaced its analog system with an advanced Digital Data Acquisition system. Except for a few computer support services provided by an outside specialist, Orenda Turbines performed all the tasks needed to install and integrate this system into its Engine Test Facility.

The Digital Data Acquisition system uses a desktop computer with a National Instruments data acquisition board. The computer's Labview data acquisition software operates in a Microsoft Windows environment. Orenda Turbines' personnel were trained on the initial software and have subsequently made several refinements to the system. Using commercial-off-the-shelf PC-based hardware and software, Orenda Turbines created a highly flexible test environment that can accommodate any foreseeable test situation. Engine data is collected by using a wide range of sensors including pressure, humidity, flow, vibration, thermocouples, and strain gauges. Almost all signal processing is handled by the Labview software and can easily be configured to simulate any combination of signal processing elements (e.g., relatively simple averaging functions; high-speed dynamic signal analysis for vibration troubleshooting). Data is compiled and shown on large, user-friendly, full color displays that are customized to Orenda Turbines' and its customer's requirements. Automatic calibration procedures also ensure accuracy and repeatability of test results.

By implementing the Digital Data Acquisition system, Orenda Turbines has virtually eliminated data logging and calculation errors. The automated detection and recording of exceeded engine limits allow operators to make additional measurements as needed, thereby reducing the number of required test runs and operator workload. The real-time display of corrected engine measurements also lets operators make immediate comparisons with the Technical Order acceptance limits. As a result, Orenda Turbines reduced its test times by up to 75%. The Digital Data Acquisition system requires less maintenance and is easily supported compared to its predecessor. The system's increased flexibility enables greater utilization of test cells because multiple engine types can be tested within one cell. Since implementing this system, Orenda Turbines' Test Cell Engineering Group has become a supplier of new engine testing facilities and upgrading services for external customers.

#### *Production*

##### Advanced Repairs

In the past, Orenda Turbines performed all repairs in accordance with the Original Equipment Manufacturer's specifications. This approach did not place any emphasis on improved durability and promoted only conventional repair techniques. As a result, Orenda Turbines developed a Failure Modes and Effects Criticality Analysis (FMECA)-based system for determining certification requirements, and a design-approval process for certification.

Millennium technologies are now being applied to engines which were designed 20 to 30 years ago. Parts are being re-manufactured to increase part strength in weak areas, such as using a laser alloy on turbine blade tips to prevent tip erosion. Orenda Turbines also employs state-of-the-art techniques (e.g., laser reverse machining; water jet cutting and coating stripping; chemical vapor deposition coating; electron beam physical vapor deposition coating) during the repair process. A sophisticated cost-benefit analysis is performed to obtain realistic cost-savings information and help the company make informed decisions regarding repair techniques. This approach enables

---

the most cost-effective repair for the entire life cycle to be performed.

The repair cost-benefit analysis cannot be calculated by comparing the new part price to the repair cost. The certification procedures must be based on a rigorous FMECA. By applying advanced technologies, Orenda can double component life in the case of older technology engines. Canada's Department of National Defence (DND) sponsored a National Durability Initiative to foster cooperation between industry and national laboratories, and to apply advanced technologies to products. All repair techniques must be approved by civil and/or military airworthiness authorities under design approval organization status. Orenda Turbines' use of advanced repair techniques are projected to save the Canadian Forces (CF) F404 Engine Fleet approximately \$60 million (U.S.) through the year 2012.

### Butler Newall High Speed Blade Tip Grinder

When the F404 engine program began in 1984, the common practice for replacing damaged blades consisted of using a modified engine lathe to manually grind the blades. These high-pressure, compressor rotor blades were set at their innermost position and ground at a speed of 35 rpm. In addition, the method for measuring a blade's radius was equally crude and unreliable. At Orenda Turbines, a lathe setup with probes inserted into a calibrated master block was used to measure the blade tips. Although better than most methods at the time, this approach was still unable to produce consistently sized rotors as specified by program requirements. In 1987, the CF asked Orenda Turbines to investigate ways of improving the accuracy of rotor tip radius measurements and of producing a rounder and more consistently sized rotor.

As a result of its investigation, Orenda Turbines purchased a Butler Newall High Speed Tip Grinder in 1989 at a cost of \$2.25 million (Canadian). Significant features of this machine include providing hardcopy readouts of all blade sizes; highlighting out-of-tolerance blade readings; achieving a repeatability accuracy of 0.0005 of an inch; and grinding rotor blades at a speed of 3,000 rpm. This latter feature allows blades to be extended to their fullest length, thereby simulating the operational mode of the rotors and resulting in a consistently round finished rotor. Setup of the rotor is accomplished off the machine by using modular fixtures. This design offers quick changeout from one

rotor to the next. Blade tip measurements are performed by a built-in laser measuring system. The information is then relayed to the controller which provides a visual readout for the operator as well as a printed hardcopy report. The machine can also handle rotors up to 36 inches in diameter and up to 59 inches in length.

Although there are 52 of these machines currently in service throughout the world, Orenda Turbines has the only one being used in Canada. Additionally, the accuracy of the Butler Newall High Speed Tip Grinders has resulted in General Electric using it to check and verify its Master F404 HPC Rotor.

### F404 Best Build Process

The four rotor assemblies that make up the F404 engine contain several life-limited components which must be replaced before their predefined life cycles expire. Although each component's life cycle is different, the past practice of reassembling the original components on the rotors during repair and overhaul did not present much of a problem. The main reasons were because the engines were new and the components were in the early stages of their life cycles. However, as the rotors aged, the life cycles also began maturing which caused the rotors to be frequently returned to the Depots for component replacement. Realizing that it needed a process to ensure the maximum service life of repaired rotors, Orenda Turbines introduced the F404 Best Build process in 1996.

Orenda Turbines developed the Best Build process by creating a computer-based process that took advantage of the company's Equipment Condition Monitoring System, an existing database used since the mid-1980s. The Best Build process matches individual components (based on remaining service life) from the rotor assemblies currently undergoing repairs. Each match is based on real-life data of the component's life cycle. Using an interactive process, the program selects a combination of parts and conducts a calculation for each combination of components to determine how many times the rotor assembly will have to be returned before all of the life cycled components need replacing. Once the program selects the best combination of components for each rotor, a build sheet describing each component is generated and the specified components are removed from the database inventory. The program also determines the value of the throwaway lives of parts which have not yet exhausted their life cycles.

---

Orenda's Best Build process has proven to be beneficial to the CF, which rates its field maintenance facilities on their ability to build and repair engines that can remain in service for the maximum number of hours. Since implementing its process, Orenda Turbines now builds all rotor assemblies for the CF's maintenance facilities with the maximum life cycle parts available. As a result, the company can ensure extended service hours as well as reduce the number of acceptable life cycle parts discarded.

### Moment Weight Measurement System

To properly balance a set of blades on a rotor, one must first measure the moment weight of each blade and then install the blades in a sequence which optimally distributes the weight over the rotor. Done correctly, the rotor will remain in balance when operated at a high velocity. Orenda Turbines previously used a time-consuming method to accomplish this task. Each blade was weighed using a calibrated moment weight index to determine the moment weight. This value was handwritten on the blade, and then all the blades were sequentially lined up on a work table from heaviest to lightest. Next, the blades were paired up and checked to ensure that the moment weight difference of each pair was less than 5.0 gram-inches. Based on a predefined way, the pairs were installed opposite each other into a fixture. Once the blades were set up, the technician manually filled out a build sheet to record the blade and rotor information such as sequence number, serial number, moment weight, and other data. After the build sheet was completed, the blades were removed from the fixture and installed into the rotor. This approach provided many opportunities for recording errors which might not be caught until after the build was completed, leading to teardown and rework operations.

In 1998, Orenda Turbines developed the Moment Weight Measurement system. This system automates most of the operations and error-proofs the data entry. Now, the required number of blades are selected and simply labeled 1,2,3, etc. The serial number of each blade is entered into the computer as the blade is placed in the moment weight index for weighing. The computer automatically enters the moment weight directly from the weight index instrument, and checks to make sure that the serial number is correct and not a duplicate. This feature guarantees that only unique serial numbers are used for each blade. When all of the blades have been entered, the operator checks the moment weight

difference between each pair of blades which are optimally sequenced by the computer. The computer then produces an installation list showing the installation sequence, and automatically generates and prints a build sheet. The need to place the blades in an interim fixture is completely eliminated.

Compared to the previous method, the Moment Weight Measurement system has produced significant advantages and benefits for Orenda Turbines. The system eliminated tedious and manual steps which were prone to errors; reduced the cycle time for blade sequencing and installation by more than 50%; and produces an annual savings of about \$40,000. Documents generated during the measuring process are always consistent, and the build sequence is the best possible match. In 1998, the developer of the Moment Weight Measurement system won first prize in Orenda Turbines' Idea Recognition System annual competition.

### Repair Scheme Development

Procurement of new turbine engines, engine modules, and components is very expensive. Orenda Turbines recognizes that it is more economical to repair a component, if possible, than to discard the defective part and replace it with a new component — even when the repairs are not covered by existing instructions. Consequently, the development of new repair schemes has become a significant element in Orenda Turbines' repair/overhaul philosophy and capability.

As engine components age over years of operation, unserviceable conditions will arise that are not covered by existing repair instructions. Therefore, new repair schemes must be developed which can produce a viable and cost-effective repair. At Orenda Turbines, this approach works best when the number of components requiring repair is fairly large. The typical scenario involves waiting until several components are rejected for the same unserviceable feature, which ensures that the first incident is not unique. Next, the defective component is reviewed by a group of experts, and a scheme is devised to repair the defect. Depending on the customer and the nature of the defect, it may be necessary to obtain authorization to proceed and validate the repairs on one or more of the rejected components. With approval and a plan of action, a repair scheme is developed to carry out the trial operation. Depending on the complexity of the repair, several trials may be required to achieve a viable repair scheme and a serviceable component.

Most repairs are simple enough that proof testing is not necessary. Engineering principles dictate whether additional testing is required to validate the soundness of the repair.

Orenda Turbines has demonstrated its Repair Scheme Development capability on numerous engine components, typically at a fraction of the cost of buying a new component. Three examples include:

- Combustion Liner Assembly — The customer presented a repair scheme for its combustion liner assembly that was inadequate and lacking in detail and tooling. Orenda Turbines changed the scheme and redesigned the tooling, making it possible to repair the assembly for approximately 15% of the cost of a new part.
- F404 Oil Tank Assembly — This repair involved end-cap replacement which needed to meet stringent welding requirements for aluminum structures. Orenda Turbines introduced a backing ring that permitted the welding process to be conducted while maintaining the integrity of the weld and the affected components (Figure 2-1). The new techniques enabled the company to produce a repaired assembly for less than 5% of the cost of a new part.

- Combustion Chamber Case — This situation involved severe wear at the forward end where the outlet guide vane fits to the casing, thereby affecting the land and the groove. Orenda Turbines created repair activities for both components. The scheme was implemented with great success and is in place today, producing a repair cost of only 10% of the cost of a new part.

### Travel Card Generator

Orenda Turbines overhauls and repairs a wide variety of engine components and parts, many of which require multiple repairs. Each repair is tracked via a travel card, which is routed through the shop as the part proceeds through its repair operations. In the past, these cards were generated by hand. A part requiring multiple repairs would have multiple cards. Since these cards were manually combined, the result was often an inefficient sequencing of repairs and/or duplication of operations. In some cases, parts were routed individually for each repair. This was a significant driver of high turnaround times and costs. The need to streamline this process became a high priority. In 1992, Orenda Turbines developed and implemented the Travel Card Generator (TCG).

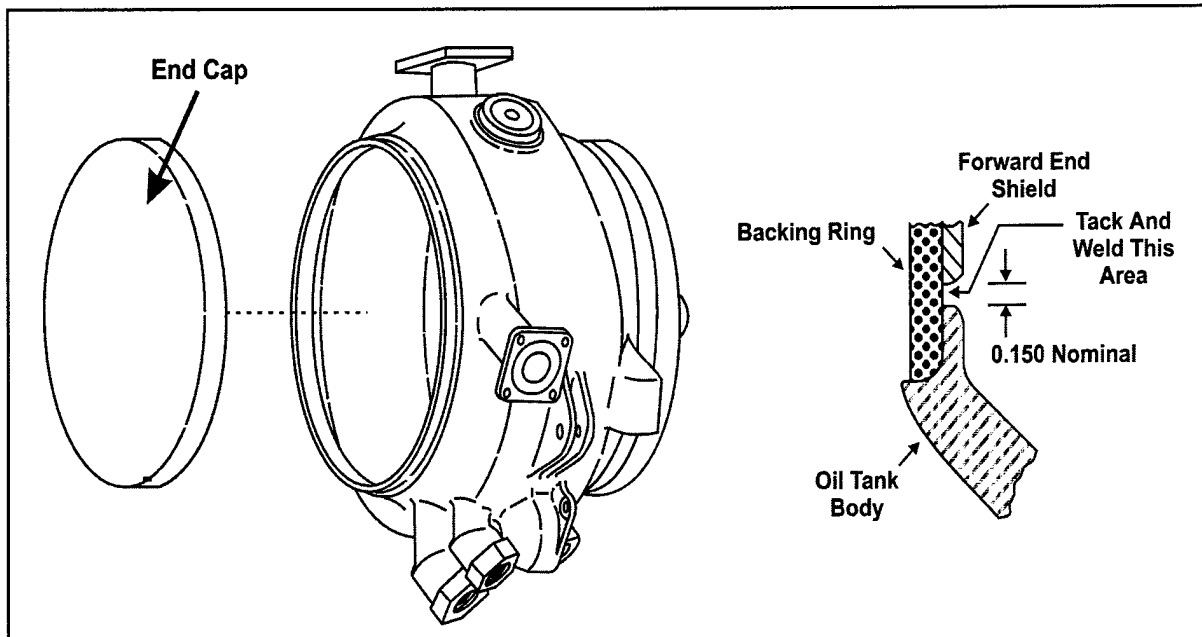

Figure 2-1. F404 Oil Tank Assembly

The TCG enabled Orenda Turbines to computerize the production of travel cards, allowing for the combination of multiple repairs with the least amount of duplication and part travel. This DOS-based system is linked to a database containing the approved repairs for all components that the company handles. End users can select any combination of repairs and the TCG will arrange the operations based on a priority logic numbering system. Each component entering the repair system is given an identification number that is tied to the TCG. All approved repairs for a specific component are then listed under a code number tied to the identification number. To generate a travel card, the operator enters this six-digit number and the TCG displays a list of approved repairs for the component. Based on the induction assessment reports, the operator can then select the processes required to repair the part. The combined list of repairs can be further tailored and refined by the operator as needed. All essential information including the header is automatically entered by the computer when the card is printed, including the bar codes used to track the part and the labor applied in the repair process.

The TCG has enabled Orenda Turbines to significantly improve its cycle time by eliminating redundant and inefficient operations, and optimizing the routing of parts through the shop. When multiple repairs are selected, the TCG combines equivalent operations, puts similar operations together, and greatly reduces the amount of travel in the shop. This system also includes the most current version of the operation sheet on the travel card, ensuring that technicians have the latest repair instructions. Currently, Orenda Turbines is updating the TCG to a Windows-compatible version and integrating it into the company's Enterprise Resource Planning system.

## Logistics

### Equipment Condition Monitoring System

Orenda Turbines' capabilities include turbine engine repair and overhaul services for the commercial and government sectors of the aerospace industry. The CF-18F404 turbine engines used by the DND CF

require a Maintenance Management Support System and an Electronic Engine Logset. Since 1987, Orenda Turbines satisfied these requirements with a mini-computer based Engine Parts Life Tracking System which, in 1997, was migrated to the PC-based Equipment Condition Monitoring System. This life/maintenance tracking system captures and monitors the location, configuration, status, accumulated use, and service history of fielded turbine engines. The Equipment Condition Monitoring System employs relational database technology with a complete suite of graphic user interface software tools for data entry, processing, and report generation. The system operates on client/server local area networks (LANs) (Figure 2-2) and is interconnected by a wide area network.

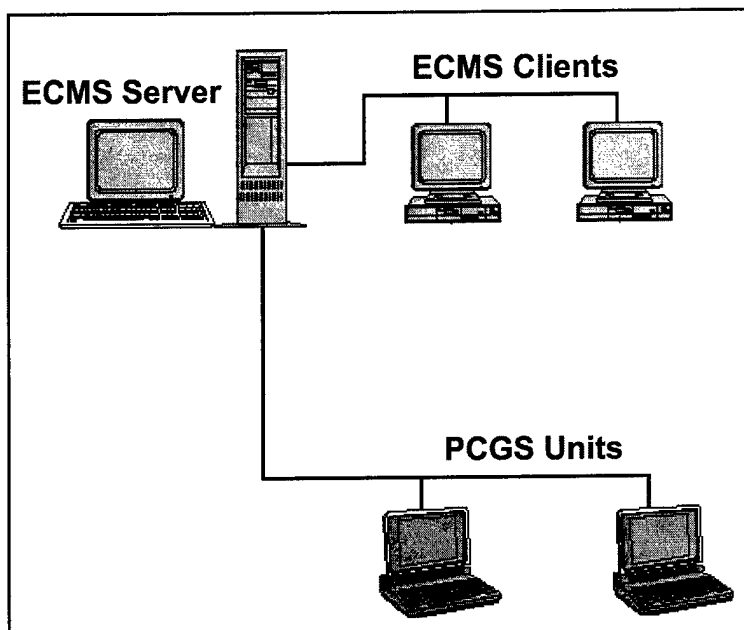

Figure 2-2. Equipment Condition Monitoring System LAN

The Equipment Condition Monitoring System's applications consist of the Personal Computer Ground Station (PCGS); the Engine Condition Monitoring System; and the Engine Maintenance Reporting System (EMRS). The PCGS acts as the interface between the aircraft and the ground system in the field; creates an aircraft file; and provides aircraft data files back to Orenda Turbines. The Engine Condition Monitoring System captures, processes, and reduces the data so the company can easily monitor values, track trends, and forecast cost-effective engine removals from the field for repair and overhaul. Data

---

is collected from the engines, the main modules, and the components. Life Used Index values (e.g., thermal cycles, time of engine use, speed excursions) are tracked, leading to low cycle fatigue counts. This system is updated daily, rather than just being a periodic snapshot. The EMRS captures data on items not tracked by the Engine Condition Monitoring System.

Orenda Turbines' Equipment Condition Monitoring System team consists of five employees. Their daily operations support integrity of the engine logset by identifying and correcting data errors caused by software problems (regardless of source data), late entries of maintenance actions, or incorrect data entries. The team satisfies requests for inventory records from one operation site to another, and performs data entries for other third-line contractors as necessary. In addition, the team introduces tracking of new part numbers and/or life limit definitions into the system; introduces tracking of new items and/or changes to DND's operational requirements; maintains the database; generates reports; and performs data analysis for forecasting and logistics planning by the engine managers. The LAN system engineering activities configure and maintain the servers and clients to current OS/2 standards; ensure daily Oracle database exports and system backups; implement software updates; change LANs to conform to DND's network protocol; and configure systems for long-term deployments. The team generates procedures and utilities to work-around deficiencies in the Equipment Condition Monitoring System's software, as well as reporting procedures to facilitate engine management and engineering support; electronic document interchange between Headquarters, Bases, and Orenda Turbines; and large electronic file transfers from Bases to Archiving Sites.

Prior to Orenda implementing the Equipment Condition Monitoring System, data management was less than optimal — now all operations are characterized by rapid response and reliable data. The primary goal of contractual compliance with the CF has been met. As a result, Orenda Turbines provides savings for its customer by optimizing the repair and overhaul operations through better control and better matching of the application with the actual requirement.

## ***Management***

### **Asset Management System**

Orenda Turbines repairs F404 exhaust frames for the CF and the U.S. Navy. Per the Navy's contractual requirements, the company must have adequate

control over the government-owned property while under its charge. In 1994, Orenda Turbines developed the Asset Management System (AMS), a Microsoft Access, LAN-based program which provides real-time tracking.

The AMS consists of three main components:

- **Tracking** — Accurately tracks the turnaround time of each exhaust frame, and allows users to enter the dates for receipt, allocation, induction, and shipping. Based on these dates, the average turnaround time is calculated for all frames shipped in a given month.
- **Scheduling** — Calculates a monthly repair schedule based on the repair quantities entered by the supervisor. This schedule indicates the dates to strip, clean, repair, and ship each frame in a given month, based on a 30-day turnaround time.
- **Managing** — Maintains a consistent workload on the shop floor, and monitors how many frames are: work in process, awaiting allocation, and awaiting induction. In addition, an overall program summary shows how many frames have been shipped to date, how many have been shipped monthly, and how many non-contract items have been received.

The AMS uses simple to follow screens for data entry and retrieval, and maintains information integrity by only granting screen accessibility to authorized users. The primary user screens are Transportation, Production, History, Scheduling, Contract Administration, and Performance. The Transportation screen allows users to enter the item type, serial number of a received item, shipment date of a repaired item, and associated documents. The Production screen allows users to enter work order assignments, and the date and serial number of allocated and inducted items. The History screen allows users to view and/or edit the status of items entered into the system. The Scheduling screen allows users to create, preview, and/or delete schedules. The Contract Administration screen allows users to transfer information (e.g., milestone, contractual discrepancy) to the U.S. Navy's Commercial Asset Visibility computer system. The Performance screen allows users to view daily and monthly program status, work-in-progress items, and turnaround times. All users can access the General Information screens.

Orenda Turbines designed the AMS to be structured, yet flexible for change. Annual audits performed by Government Services Canada and the company's Public Works Department, on behalf of the

---

U.S. Navy, report that the AMS fully complies with Navy requirements to demonstrate control of government-owned property. Orenda Turbines also benefited from the AMS by using its data to analyze and improve the turnaround times of internal processes. Future plans are to integrate the system into the company's Enterprise Resource Planning system.

### Corrective Action and Deviation Report Database Systems

Orenda Turbines developed two database systems for managing, assigning, responding, validating, tracking, trending, and approving root cause and corrective actions. The Corrective Action (CA) Database addresses actions related to nonconformance from customer complaints, quality systems, and procedural issues. The Deviation Report (DR) Database addresses actions related to nonconforming products. The company's previous method compiled the information manually, was unresponsive, and had limited analysis and tracking capabilities.

The CA Database has been in operation since 1997, while the DR Database is currently being implemented. In developing both systems, Orenda Turbines drew heavily on automotive industry experience and methods for closed-loop tracking and management of nonconformances and corrective actions. These systems are designed to comply with industry standards, procedures, and customer requirements, and to incorporate best practices identified by benchmarking.

Once the corrective action is entered into the CA Database system, it is controlled throughout the entire analysis and tracking process. Users can review all information; conduct on-line root cause analysis and verification; and view or print tracking reports. The system is supported by Microsoft Access and Visual Basic, and is linked with Orenda Turbines' Approved Supplier Database and GroupWise mail system. This arrangement enables information to flow rapidly and progressively to all involved personnel, thereby assuring timely resolution. Since the CA Database is an activity-based system, activities cannot occur out of sequence. Continuous trend charts and reports allow users to track the status of all assignments. Additionally, the system is linked with the supplier, customer, and internal e-mail systems. As a result, notifications and actions move rapidly and in sequence. Password-protected electronic signatures help ensure the integrity of the database.

Since implementing the CA Database system, Orenda Turbines has seen significant cost reductions due to improved responsiveness and accuracy. Administrative workload for quality tracking and management has decreased by nearly 75%. Orenda Turbines plans to incorporate the CA and DR Database systems into the company's Enterprise Resource Planning system.

### Financial Reporting Tools

Orenda Turbines believes the ability to maximize profitability while containing customer costs depends more on the application of good, practical business sense by managers and employees, and less on high-tech, automated financial systems. In 1995, the Finance Department developed user-friendly tools and resources to assist managers and supervisors in managing their resources effectively and efficiently. Prior to these tools, the Department recognized that its system-generated cost reports were rarely, if at all, being utilized by department managers. The reason was because these bulky, batch print-outs were too long, detailed, and complex. Line managers did not have the time or financial expertise to decipher and use them.

The Finance Department began looking at ways to provide simple, accurate, timely reports. The Department also wanted to introduce line supervisors and managers to methods and techniques that would contribute to cost improvements and increased profits. They recognized that the most effective ways to improve profitability, while keeping customer costs down, were to reduce overhead and shorten turnaround time. They developed visual methods to display overhead costs and turnaround times by placing white boards on the shop floor. These boards show sales; cost of sales; gross margin by major product line; real-production times; and customer turnaround times in a visible and easy-to-understand format. The old financial data print-outs were eliminated and replaced with a weekly employee utilization report that clearly shows managers the productive and non-productive times for their workers. The employee utilization report helps managers ensure that their workers are engaged in useful and effective activities. Another report used is a one-page summary for all departments which displays manpower utilization and weekly trends. In addition, brief lectures are provided as part of the weekly Continuous Improvement Meeting on finance topics such as financial ratios, letters of credit, budgeting, and understanding financial statements.

Orenda Turbines' tools and resources have raised the visibility and level of understanding of critical financial measures and made them useful to line managers for improving overall performance. Since this information became available, overhead charges by direct labor personnel decreased by 30%. The company also reduced lateness, absences, and other non-productive time activities by nearly 60%, which significantly increased profitability. Additionally, the weekly lectures have produced cross-training benefits and improved employee utilization.

### Firm Pricing Model for Engineering Support Services

Orenda Turbines provides Technical Investigations and Engineering Support (TIES) services as part of its engine repair and overhaul services to the CF. In the past, the company negotiated this type of multi-year contract on a cost-plus basis — the actual number of hours incurred (up to a maximum) times the negotiated hourly labor rate for each task. With this approach, there was no incentive for Orenda Turbines to become more efficient nor to reduce the number of hours required. In fact, the opposite was true — more hours meant more revenue. The cost-plus approach had limited profit potential for Orenda Turbines and did not contribute to increasing the company's competitiveness. From the customer's standpoint, there was little potential for cost reduction. To improve this situation, Orenda Turbines implemented a Firm Pricing Model for Engineering Support Services. This system enables the company to negotiate the contract using a fixed-price model, whereby gains resulting from efficiency improvements are shared by Orenda Turbines and the customer.

Under the Firm Pricing Model (Figure 2-3), Orenda Turbines and the Canadian government negotiate in advance a fixed number of hours to perform an agreed Engineering Support package for each one-year period of the contract. They also determine a labor rate separately and apply it to the number of hours to calculate the yearly price, which is paid in 12-equal monthly installments. If Orenda Turbines incurs more time to perform the contract tasks than has been negotiated, the company absorbs the extra costs. If it takes less time, Orenda Turbines' profit margin will be higher. The company reports the actual hours worked to the customer for each contract period. Using an agreed upon formula, Orenda Turbines and the customer will reduce the specified hours in the next contract period by a portion of the difference

between actual and contracted hours in the previous period. In the early years of a contract, the government retains the larger share of the difference because the initial improvements are easier for Orenda Turbines to achieve. In the later years of a contract, Orenda Turbines retains the larger share because these improvements are now more difficult to accomplish.

The Engineering Support aspects of TIES lend themselves to the Firm Pricing Model because they are well defined, continuous, and stable. However,

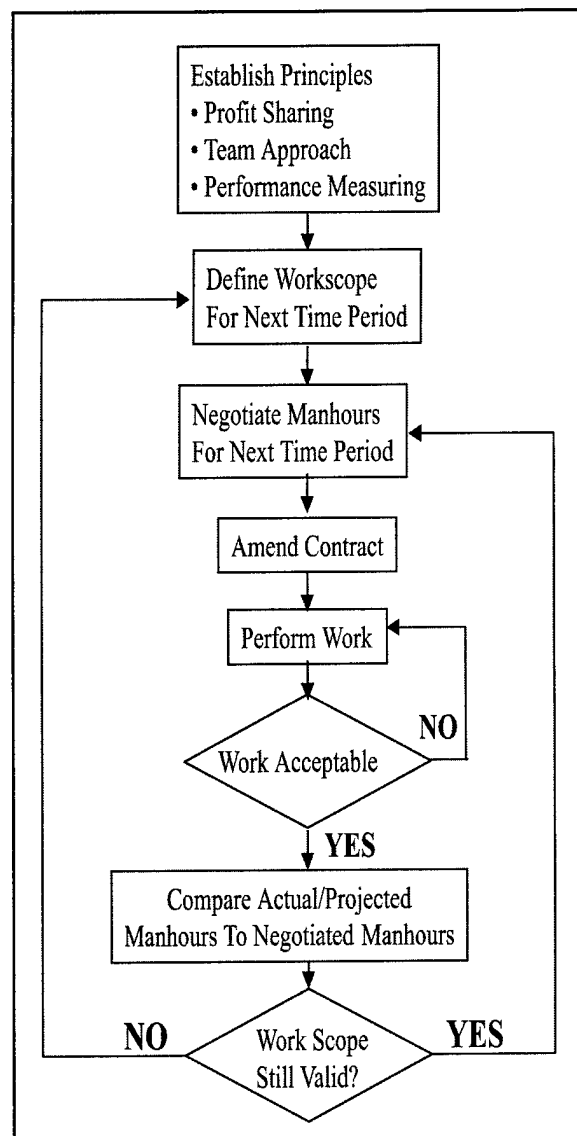

Figure 2-3. Firm Pricing of Engineering Support

---

Orenda Turbines continues to price Technical Investigations on a cost-plus basis since their number and scope cannot be accurately estimated in advance. A key factor in the successful implementation of the Firm Pricing Model is mutual trust. The approach would fail if either party abused it (e.g., the supplier cut corners on some activities to increase profit; the customer tried to include additional activities to the workscope without adjusting the contracted hours). To ensure that the work performed under the system meets customer requirements, Orenda Turbines asked the CF to implement a feedback system in which it rates the performance of each Engineering Support task performed by the company on a monthly basis. This feedback system has helped validate the effectiveness of the Firm Pricing Model.

The Firm Pricing Model enables Orenda Turbines to make more profit than it would using the cost-plus approach while allowing the customer to benefit from consistently decreasing costs. Between 1993 and 1999, the Engineering Support contract hours for one engine program were reduced by 43%. Orenda Turbines and the CF are currently increasing the workscope to include the provision of two technical service representatives at the operating bases.

### Measures of Performance System

To improve one's business, an indication of performance is necessary to determine the current status of one's company and the target for which one is striving. In the past, Orenda Turbines' performance measurements were not formalized. Understanding and applying measures of performance varied throughout the company. A few resulted in producing effective tools, but most did not. In 1996, Orenda Turbines resolved this situation by developing the Measures of Performance (MOP) system, which has evolved into a reliable and effective tool for improving the company's business.

The MOP system is a Microsoft Access, LAN-based program designed to provide weekly performance measurements pertaining to turnaround times, cycle times, subcontractor turnaround times, reworks, and work-in-process levels. The key to developing these indicators was to focus on a few measurable factors which would have the greatest effect on customer services. Turnaround time measures how many parts are being delivered to the customers beyond the scheduled date. Cycle time measures how long parts remain idle on the shop floor before advancing to the next stage. Subcontractor turnaround time

measures how long parts spend outside the company at a subcontractor's site. Rework measures how much time was spent reworking the parts. Work-in-process levels measure the number of parts in process on the shop floor. Each indicator relates directly to a delivery schedule or cost. All of Orenda Turbines' business units subscribe to the same standard indicators. The MOP system uses easy-to-follow screens for data entry and retrieval. The measures of performance are reviewed weekly by management, team leaders, and cell leaders. Charts are posted throughout the company for all to see.

The MOP system has proven to be an effective tool for improving business operations and enabled Orenda Turbines to obtain a better understanding of performance. This company-wide application continues to improve processes to reduce scrap, reduce inventories to shorten cycle times, and efficiently control assets to reduce work-in-process levels.

### Work Cell Development

In the past, Orenda Turbines used a traditional, shop floor manufacturing flow (e.g., tear-down, strip and clean, preparation, welding, heat treat, assembly, inspection) to repair exhaust frame assemblies. This approach involved long movement runs, queue times, minimal ownership, and competition for parts with other work on the floor. As a result, Orenda Turbines' repair time was 250 hours per exhaust frame assembly, and its turnaround time was 200 days. Encouraged by the prospect of winning a major U.S. Navy contract in 1994, Orenda Turbines developed a manufacturing Work Cell capability which dramatically improved its repair and overhaul operations for F404 exhaust frame assemblies.

Using a multi-discipline team of supervisors and shop personnel, Orenda Turbines analyzed ways to redesign its operations, reduce costs, and improve turnaround time. The result was the introduction of the manufacturing Work Cell. The company implemented simulation models to optimize the flow of parts; analyzed previous repair trends to predict the frequency of repair conditions; and performed resource calculations on small groups of operations both within the Work Cell (e.g., strip, assess, bare frame repairs, detail repairs, initial assembly, final assembly, braze, pressure test) and outside of the Work Cell (e.g., furnace, plastic media blasting, fluorescent die testing, plasma spray) to produce standard times and resource requirements. Additionally, Orenda Turbines reorganized groups of operations to eliminate

---

bottlenecks; designed and fabricated new tooling; and justified and procured capital equipment. The shop floor was also redesigned to maximize the layout of equipment, offices, and storage spaces. Repair and purchase costs were analyzed to optimize efficiency, and operators were accredited to inspect their own work. Orenda Turbines also implemented an improved Travel Card Generator, Measures of Performance, and Asset Management System.

As a result of its efforts, Orenda Turbines reduced repair time to 85 hours per exhaust frame assembly; decreased turnaround time to 30 days; and won the U.S. Navy contract. The manufacturing Work Cell

can perform multiple repair operations on 14 separate components for the exhaust frame assemblies. Orenda Turbines' unique expertise in Repair Scheme Development allows the company to excel in this area. Recently, the company developed an in-house capability for applying thermal barrier coatings by using plasma spray technology. This capability further reduced costs and turnaround times by eliminating the need to subcontract. Since implementing the manufacturing Work Cell, Orenda Turbines repaired and shipped more than 300 units to the CF and 1,300 units to the U.S. Navy.

---

## Section 3

### *Information*

---

#### *Production*

##### BioFuel

There has been an increased worldwide emphasis on fossil fuel usage reductions. As a result, Orenda Turbines is developing technologies for a gas turbine engine/generator/steam plant that runs on liquid BioFuel. BioFuel can be made from wood, wood residues, straw, grasses, bagasse, cane trash, lignin, cellulose, agricultural residues, palm shells, and/or waste paper. Orenda Turbines produces BioFuel with a third-party, proprietary system based on a fast pyrolysis process. The liquid fuel is made at a central processing site and then transported via conventional means to the point of use.

Waste products are ground and heated under vacuum, and the resulting vapors from the heating are condensed to heavy and light oils. The non-condensable vapors are burned to provide the heat input to the process. Vast quantities of agricultural and other wastes are available in many parts of the world, and provide the raw input material for the process. Orenda Turbines developed the system to run a 2.5 Megawatt gas turbine engine (Mashproekt GT2500) at full power on BioFuel. Obstacles in using BioFuel included high viscosity, corrosiveness, and ash content; lower heating value; and difficulty in igniting the fuel. High viscosity was resolved by preheating the fuel. The corrosive nature of the fuel was mitigated by using protective coatings and fuel additives. The ash content was lowered by changing the fuel processing parameters. The difficulty in igniting was resolved by starting the engine on conventional fuels, and then switching back to conventional fuels before shutting down the engine. As for the lower heating value, no resolution currently exists.

By using the BioFuel engine, Orenda Turbines demonstrated a reduction in NOx and SOx levels compared to diesel fueled engines. The company projects a reduction in carbon dioxide emissions by 17,000 tons per engine per year.

#### Front Frame Strut Repair Process

Orenda Turbines began manufacturing front frame strut assemblies for the F404-GE-400 engine in the late 1980s. Because of its location on the engine, this assembly incurred a number of problems early in service. The struts that support the hub assembly were susceptible to damage from objects which were ingested into the engine during operation. Often this damage was severe enough to render the entire frame assembly unserviceable. Another potential problem involved the three struts that contained the service tubes for the oil system to the main engine bearing. If any of these tubes developed cracks, broke inside a strut, or broke within the anti-icing manifold, the frame assembly was rendered unserviceable. To address these problems, Orenda Turbines developed the Front Frame Strut Repair process.

Using the expertise and tooling that had been developed for the manufacture of new hub assemblies, Orenda Turbines designed repair procedures to address used and damaged assemblies. These procedures enable the individual struts within a damaged frame assembly to be removed and replaced. In addition, any cracked or broken oil supply lines can be repaired without causing damage to the surrounding areas of the frame. Once repaired, the assembly is inspected and pressure tested to ensure proper operation.

Because of its expertise and successful repair history with this component, Orenda Turbines is now the sole-source provider for front frame strut replacement in the F404-GE-400 engine. The company is referenced in the U.S. Navy's maintenance manual and has performed successful repairs for several other countries which use this engine.

#### Plasma Spraying

In the past, thermal spray processes at Orenda Turbines were subcontracted to several off-site vendors in the U.S. and Canada. The vendors handled the masking, preparation, spraying, and testing op-

---

erations, while Orenda Turbines monitored the process by performing verification testing and audits of the final product. This approach resulted in poor schedule adherence, lack of process control, cost overruns, and inconsistent product quality. To resolve these problems and improve customer satisfaction, Orenda Turbines began investigating thermal spray technology. In 1996, the company purchased a Miller 4500 Robotic Spray system.

The Miller 4500 Robotic Spray system consists of a six-axis articulated arm robot integrated with a turntable and a programmable controller. Using data acquisition hardware and software, the system controls, monitors, and records the plasma spray parameters. The system can accept multiple spray gun configurations and is enclosed within an acoustical spray room for noise control. Orenda Turbines' Materials Services Laboratory now performs all in-house coating and evaluations of the process. As a result, the company improved its coating quality and consistency; increased production; developed better schedule adherence; and obtained more accurate and comprehensive data acquisition. A typical job involves applying an abrasion-resistant seal coating on a stator assembly. If the job is subcontracted, a batch of six costs \$470 each (including shipping) with a turnaround time of seven days. By performing this job in-house, Orenda Turbines reduced the total cost to \$350 each with a turnaround time of eight hours.

Plasma spraying is a complex process that requires dedicated technical support to achieve consistent quality. In addition, the many variables which impact the quality of the finished product must be consistently monitored. By performing plasma spray capabilities in-house, Orenda Turbines achieves better product quality, shortens cycle times, and improves customer satisfaction.

## ***Facilities***

### **Co-Generation Project**

Orenda Turbines has over 35 years of experience as a supplier and service provider of industrial gas turbine engines. Through a cooperative agreement, Orenda Turbines is combining this expertise with that of its strategic partners, Ukraine-based gas turbine design and manufacturing companies SPE Mashproekt and PA Zorya, to address the needs of a rapidly developing market for independent power production. The Co-Generation Project involves the development of an electricity/heat co-generation sys-

tem based on the GT2500 industrial gas turbine engine. Once installed, the system will supply electrical power and heat for Orenda Aerospace's 750,000-square foot plant. Currently, the company purchases electricity from a public utility (mostly nuclear and coal generation) and uses two diesel-fed boilers to heat its facility.

The OGT2500 package is based on a Mashproekt industrial gas turbine engine coupled to an air-cooled, four-pole electrical generator. The installed system provides nominally 2.7 Megawatts of electrical power at ISO efficiency of 28.5% at site conditions. Several design features maximize the system's reliability and adaptability to a wide range of customer requirements:

- The uncomplicated, single shaft, cold-end drive engine design and the common lube system for the generator, engine, and gearbox will help achieve lower maintenance costs.
- The engine's twin silo combustor design provides for ease of maintenance and flexibility in the type of fuel used.
- The epicyclic gearbox coupling the engine and generator makes the package more compact.
- The engine's right angle exhaust duct is rotatable, allowing flexibility in how the system is configured to deliver waste heat to a steam generating boiler or other use.
- The turbine and generator are housed in an acoustical enclosure that provides silencing to 85 decibels at one meter.
- The enclosed unit measures 30 x 10 x 10 feet and weighs 40 tons (excluding the exhaust and boiler).

The Co-Generation Project will be a high profile demonstration of the environmental and economical benefits achievable through a co-generation system, and will promote Orenda Turbines' capabilities as a supplier of gas turbine-based co-generation systems. The result should be lower energy costs and improved energy efficiency. In the future, Orenda Turbines may also be able to supply excess power to the local electrical utility.

## ***Management***

### **Low Carbon Monoxide Liners for OT-3 Industrial Turbines**

Orenda Turbines has supplied more than 156 industrial gas turbine systems. Approximately 90 of these units are still being used in electrical genera-

---

tion, pipeline and process gas compression, and oil pumping applications around the world. British Gas is one of Orenda Turbines' customers that uses OT-3 turbine powered gas compression packages. In 1998, this company was faced with tougher emission limits for its gas compression facilities. To keep its plants operational, British Gas needed to lower the carbon monoxide (CO) emissions (then at 1,000 milligrams per cubic meter by at least a factor of three).

This situation arose at a critical point in time for Orenda Turbines, as the company had recently begun an initiative to increase its presence in the industrial power generation market. Four years earlier, Orenda Turbines had entered into a cooperative agreement with Mashproekt, a Ukrainian industrial/marine gas turbine manufacturer, to develop a new generation of industrial gas turbine packages for power generation. Based on this previous collaboration, Orenda Turbines identified Mashproekt as a source of expertise for addressing the CO emission problem. They agreed that the most effective way to reduce CO emissions at British Gas without changing the entire installation was to redesign the OT-3 combustion liner to achieve more complete combustion.

In Fall 1998, Orenda Turbines contracted Mashproekt to undertake the redesign work. The original design included a number of wave-like perforations (wobble strips) through which cooling air entered the combustor. By eliminating these strips,

the designers reduced the supply of cooling air to the combustor and achieved a more uniform, higher temperature. The fuel nozzle was also redesigned to achieve a better fuel-air mix. As a result, these design changes reduced British Gas' CO emissions by a factor of eight to ten, significantly exceeding the environmental performance expected. Additionally, the changes are expected to improve energy efficiency for the gas compression plants. Although the higher temperature caused a slight increase in NOx from 90 to 95 milligrams per cubic meter, this minor increase in NOx is considered insignificant. The new design was completed by April 1999—a less-than-six-month turnaround time. The new OT-3 combustion liners and fuel nozzles, manufactured and installed by Orenda Turbines, are operating successfully and all British Gas OT-3s have been retrofitted with the new design.

Orenda Turbines exceeded its customer's environmental performance expectations for its OT-3 industrial gas turbine engines by sourcing new technology from an international strategic partner. This endeavor enabled Orenda Turbines' gas turbine packages to continue operating at a key customer's facility, while maintaining the company's longstanding reputation as an exceptional aftermarket service supplier. Furthermore, the project strengthened the Orenda Turbines initiative to introduce a new generation of industrial gas turbine systems.

# Appendix A

## *Table of Acronyms*

---

Acronym	Definition
AMS	Asset Management System
CA	Corrective Action
CF	Canadian Forces
CO	Carbon Monoxide
DND	Department of National Defence
DR	Deviation Report
EMRS	Engine Maintenance Reporting System
FMECA	Failure Modes and Effects Criticality Analysis
LAN	Local Area Network
MOP	Measures of Performance
PCGS	Personal Computer Ground Station
TCG	Travel Card Generator
TIES	Technical Investigations and Engineering Support

---

# Appendix B

## ***BMP Survey Team***

---

Team Member	Activity	Function
Larry Robertson (812) 854-5336	Crane Division Naval Surface Warfare Center Crane, IN	Team Chairman
Cheri Spencer (301) 403-8100	BMP Center of Excellence College Park, MD	Technical Writer
Team 1		
Larry Robertson (812) 854-5336	Naval Surface Warfare Center Crane, IN	Team Leader
Jack Tamargo (707) 642-4267	BMP Satellite Center Vallejo, CA	
Alan Underdown (613) 828-8894	Industry Canada Ottawa, Ontario, Canada	
Team 2		
Rick Purcell (301) 403-8100	BMP Center of Excellence College Park, MD	Team Leader
Larry Halbig (317) 891-9901	BMP Field Office Indianapolis, IN	

---

# Appendix C

## Critical Path Templates and BMP Templates

This survey was structured around and concentrated on the functional areas of design, test, production, facilities, logistics, and management as presented in the Department of Defense 4245.7-M, *Transition from Development to Production* document. This publication defines the proper tools—or templates—that constitute the critical path for a successful material acquisition program. It describes techniques for improving the acquisition

process by addressing it as an *industrial* process that focuses on the product's design, test, and production phases which are interrelated and interdependent disciplines.

The BMP program has continued to build on this knowledge base by developing 17 new templates that complement the existing DOD 4245.7-M templates. These BMP templates address new or emerging technologies and processes.

### “CRITICAL PATH TEMPLATES FOR TRANSITION FROM DEVELOPMENT TO PRODUCTION”

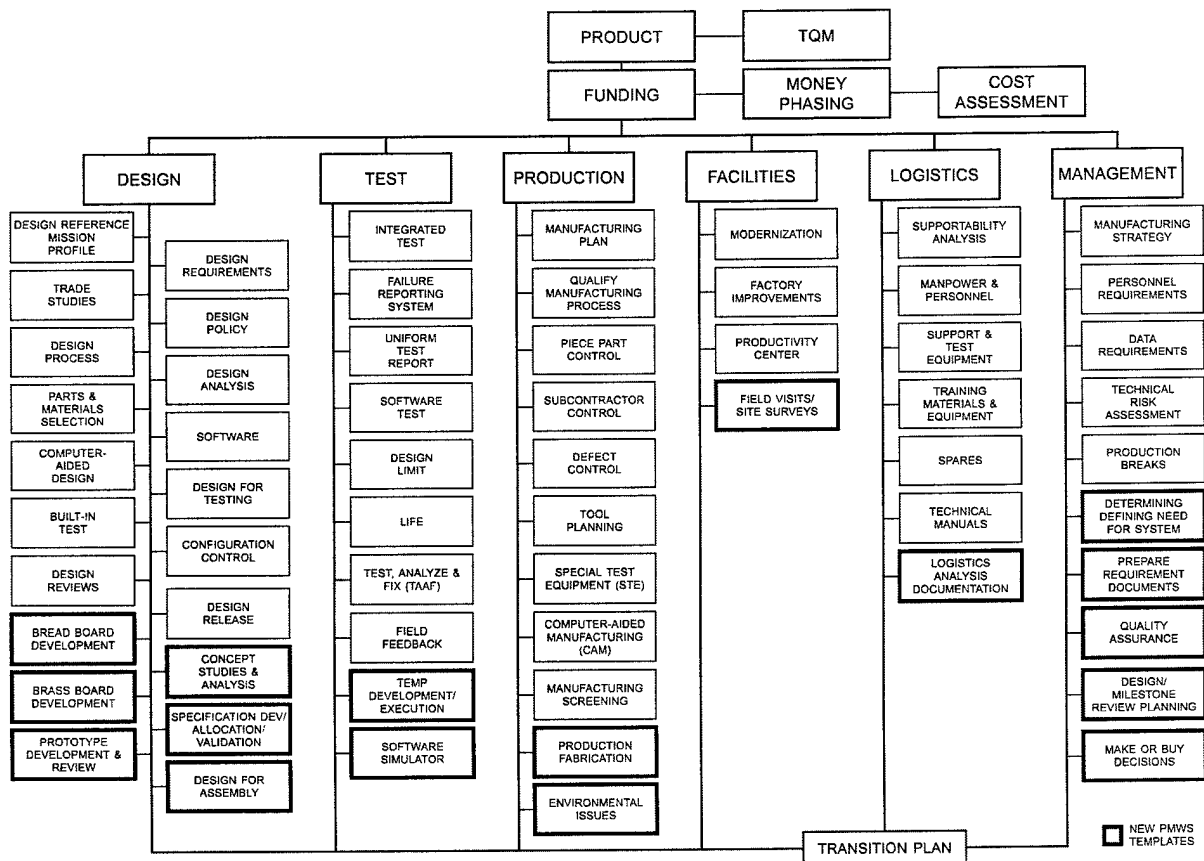

## Appendix D

### *BMPnet and the Program Manager's WorkStation*

---

The BMPnet, located at the Best Manufacturing Practices Center of Excellence (BMPCOE) in College Park, Maryland, supports several communication features. These features include the Program Manager's WorkStation (**PMWS**), electronic mail and file transfer capabilities, as well as access to Special Interest Groups (SIGs) for specific topic information and communication. The BMPnet can be accessed through the World Wide Web (at <http://www.bmpcoe.org>), through free software that connects directly over the Internet or through a modem. The PMWS software is also available on CD-ROM.

PMWS provides users with timely acquisition and engineering information through a series of interrelated software environments and knowledge-based packages. The main components of PMWS are KnowHow, SpecRite, the Technical Risk Identification and Mitigation System (TRIMS), and the BMP Database.

**KnowHow** is an intelligent, automated program that provides rapid access to information through an intelligent search capability. Information currently available in KnowHow handbooks includes Acquisition Streamlining, Non-Development Items, Value Engineering, NAVSO P-6071 (Best Practices Manual), MIL-STD-2167/2168 and the DoD 5000 series documents. KnowHow cuts document search time by 95%, providing critical, user-specific information in under three minutes.

**SpecRite** is a performance specification generator based on expert knowledge from all uniformed services. This program guides acquisition person-

nel in creating specifications for their requirements, and is structured for the build/approval process. SpecRite's knowledge-based guidance and assistance structure is modular, flexible, and provides output in MIL-STD 961D format in the form of editable WordPerfect® files.

**TRIMS**, based on DoD 4245.7-M (the transition templates), NAVSO P-6071, and DoD 5000 event-oriented acquisition, helps the user identify and rank a program's high-risk areas. By helping the user conduct a full range of risk assessments through-

out the acquisition process, TRIMS highlights areas where corrective action can be initiated before risks develop into problems. It also helps users track key project documentation from concept through production including goals, responsible personnel, and next action dates for future activities.

The **BMP Database** contains proven best practices from industry, government, and the academic communities. These best practices are in the areas of design, test, production, facilities, management, and logistics. Each practice has been

observed, verified, and documented by a team of government experts during BMP surveys.

Access to the BMPnet through dial-in or on Internet requires a special modem program. This program can be obtained by calling the BMPnet Help Desk at (301) 403-8179 or it can be downloaded from the World Wide Web at <http://www.bmpcoe.org>. To receive a user/e-mail account on the BMPnet, send a request to [helpdesk@bmpcoe.org](mailto:helpdesk@bmpcoe.org).

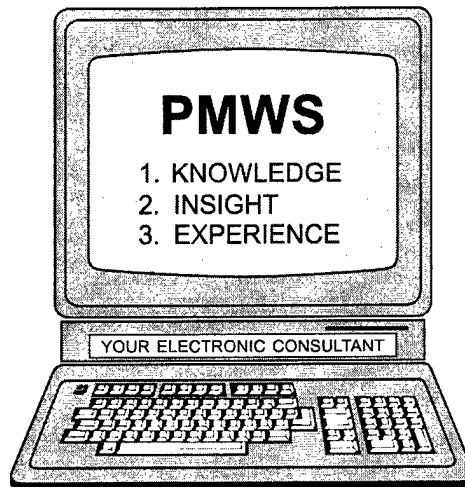

# Appendix E

## ***Best Manufacturing Practices Satellite Centers***

---

There are currently ten Best Manufacturing Practices (BMP) satellite centers that provide representation for and awareness of the BMP program to regional industry, government and academic institutions. The centers also promote the use of BMP with regional Manufacturing Technology Centers. Regional manufacturers can take advantage of the BMP satellite centers to help resolve problems, as the centers host informative, one-day regional workshops that focus on specific technical issues.

Center representatives also conduct BMP lectures at regional colleges and universities; maintain lists of experts who are potential survey team members; provide team member training; and train regional personnel in the use of BMP resources such as the BMPnet.

The ten BMP satellite centers include:

### **California**

#### **Chris Matzke**

BMP Satellite Center Manager  
Naval Warfare Assessment Division  
Code QA-21, P.O. Box 5000  
Corona, CA 91718-5000  
(909) 273-4992  
FAX: (909) 273-4123  
cmatzke@bmpcoe.org

#### **Jack Tamargo**

BMP Satellite Center Manager  
257 Cottonwood Drive  
Vallejo, CA 94591  
(707) 642-4267  
FAX: (707) 642-4267  
jtamargo@bmpcoe.org

### **District of Columbia**

#### **Chris Weller**

BMP Satellite Center Manager  
U.S. Department of Commerce  
14th Street & Constitution Avenue, NW  
Room 3876 BXA  
Washington, DC 20230  
(202) 482-8236/3795  
FAX: (202) 482-5650  
cweller@bxa.doc.gov

### **Illinois**

#### **Thomas Clark**

BMP Satellite Center Manager  
Rock Valley College  
3301 North Mulford Road  
Rockford, IL 61114  
(815) 654-5515  
FAX: (815) 654-4459  
adme3tc@rvcux1.rvc.cc.il.us

### **Iowa**

#### **Bruce Coney**

Program Manager  
Iowa Procurement Outreach Center  
200 East Grand Avenue  
Des Moines, IA 50309  
(515) 242-4888  
FAX: (515) 242-4893  
bruce.coney@ided.state.ia.us

### **Louisiana**

#### **Al Knecht**

Director  
Maritime Environmental Resources & Information  
Center  
Gulf Coast Region Maritime Technology Center  
University of New Orleans  
810 Engineering Building  
New Orleans, LA 70148  
(504) 626-8918 / (504) 280-6271  
FAX: (504) 727-4121  
atk@neosoft.com

### **Michigan**

#### **Jack Pokrzywa**

SAE/BMP Satellite Center Manager  
755 W. Big Beaver Road, Suite 1600  
Troy, MI 48084  
(248) 273-2460  
FAX: (248) 273-2494  
jackp@sae.org

#### **Roy T. Trent**

SAE/BMP Automotive Manufacturing Initiative  
Manager  
755 W. Big Beaver Road, Suite 1600  
Troy, MI 48084  
(248) 273-2455  
FAX: (248) 273-2494  
boulder@ees.eesc.com

---

**Ohio**

**Karen Malone**

BMP Satellite Center Manager  
Edison Welding Institute  
1250 Arthur E. Adams Drive  
Columbus, Ohio 43221-3585  
(614) 688-5111  
FAX: (614) 688-5001  
karen\_malone@ewi.org

**Pennsylvania**

**Sherrie Snyder**

BMP Satellite Center Manager  
MANTEC, Inc.  
P.O. Box 5046  
York, PA 17405  
(717) 843-5054, ext. 225  
FAX: (717) 854-0087  
snyderss@mantec.org

**Tennessee**

**Tammy Graham**

BMP Satellite Center Manager  
Lockheed Martin Energy Systems  
P.O. Box 2009, Bldg. 9737  
M/S 8091  
Oak Ridge, TN 37831-8091  
(423) 576-5532  
FAX: (423) 574-2000  
tgraham@bmpcoe.org

# Appendix F

## *Navy Manufacturing Technology Centers of Excellence*

---

The Navy Manufacturing Sciences and Technology Program established the following Centers of Excellence (COEs) to provide focal points for the development and technology transfer of new manufacturing processes and equipment in a cooperative environment with industry, academia, and Navy centers and laboratories. These COEs are consortium-structured for industry, academia, and government involvement in developing and implementing technologies. Each COE has a designated point of contact listed below with the individual COE information.

### **Best Manufacturing Practices Center of Excellence**

The Best Manufacturing Practices Center of Excellence (BMPCOE) provides a national resource to identify and promote exemplary manufacturing and business practices and to disseminate this information to the U.S. Industrial Base. The BMPCOE was established by the Navy's BMP program, Department of Commerce's National Institute of Standards and Technology, and the University of Maryland at College Park, Maryland. The BMPCOE improves the use of existing technology, promotes the introduction of improved technologies, and provides non-competitive means to address common problems, and has become a significant factor in countering foreign competition.

Point of Contact:  
Mr. Ernie Renner  
Best Manufacturing Practices Center of Excellence  
4321 Hartwick Road  
Suite 400  
College Park, MD 20740  
(301) 403-8100  
FAX: (301) 403-8180  
ernie@bmpcoe.org

### **Center of Excellence for Composites Manufacturing Technology**

The Center of Excellence for Composites Manufacturing Technology (CECMT) provides a national resource for the development and dissemination of composites manufacturing technology to defense contractors and subcontractors. The CECMT is managed by the Great Lakes Composites Consortium and represents a collaborative effort among industry, academia, and government to develop, evaluate, demonstrate, and test composites manufacturing technologies. The technical work is problem-driven to reflect current and future Navy needs in the composites industrial community.

Point of Contact:  
Mr. James Ray  
Center of Excellence for Composites Manufacturing Technology  
c/o GLCC, Inc.  
103 Trade Zone Drive  
Suite 26C  
West Columbia, SC 29170  
(803) 822-3708  
FAX: (803) 822-3710  
jrglcc@glcc.org

### **Electronics Manufacturing Productivity Facility**

The Electronics Manufacturing Productivity Facility (EMPF) identifies, develops, and transfers innovative electronics manufacturing processes to domestic firms in support of the manufacture of affordable military systems. The EMPF operates as a consortium comprised of industry, university, and government participants, led by the American Competitiveness Institute under a CRADA with the Navy.

Point of Contact:  
Mr. Alan Criswell  
Electronics Manufacturing Productivity Facility  
One International Plaza  
Suite 600  
Philadelphia, PA 19113  
(610) 362-1200  
FAX: (610) 362-1290  
criswell@aci-corp.org

### **National Center for Excellence in Metalworking Technology**

The National Center for Excellence in Metalworking Technology (NCEMT) provides a national center for the development, dissemination, and implementation of advanced technologies for metalworking products and processes. The NCEMT, operated by Concurrent Technologies Corporation, helps the

---

Navy and defense contractors improve manufacturing productivity and part reliability through development, deployment, training, and education for advanced metalworking technologies.

Point of Contact:  
Mr. Richard Henry  
National Center for Excellence in Metalworking  
Technology  
c/o Concurrent Technologies Corporation  
100 CTC Drive  
Johnstown, PA 15904-3374  
(814) 269-2532  
FAX: (814) 269-2501  
henry@ctc.com

### **Navy Joining Center**

The Navy Joining Center (NJC) is operated by the Edison Welding Institute and provides a national resource for the development of materials joining expertise and the deployment of emerging manufacturing technologies to Navy contractors, subcontractors, and other activities. The NJC works with the Navy to determine and evaluate joining technology requirements and conduct technology development and deployment projects to address these issues.

Point of Contact:  
Mr. David P. Edmonds  
Navy Joining Center  
1250 Arthur E. Adams Drive  
Columbus, OH 43221-3585  
(614) 688-5096  
FAX: (614) 688-5001  
dave\_edmonds@ewi.org

### **Energetics Manufacturing Technology Center**

The Energetics Manufacturing Technology Center (EMTC) addresses unique manufacturing processes and problems of the energetics industrial base to ensure the availability of affordable, quality, and safe energetics. The focus of the EMTC is on process

technology with a goal of reducing manufacturing costs while improving product quality and reliability. The EMTC also maintains a goal of development and implementation of environmentally benign energetics manufacturing processes.

Point of Contact:  
Mr. John Brough  
Energetics Manufacturing Technology Center  
Indian Head Division  
Naval Surface Warfare Center  
101 Strauss Avenue  
Building D326, Room 227  
Indian Head, MD 20640-5035  
(301) 744-4417  
DSN: 354-4417  
FAX: (301) 744-4187  
mt@command.ih.navy.mil

### **Institute for Manufacturing and Sustainment Technologies**

The Institute for Manufacturing and Sustainment Technologies (iMAST), was formerly known as Manufacturing Science and Advanced Materials Processing Institute. Located at the Pennsylvania State University's Applied Research Laboratory, the primary objective of iMAST is to address challenges relative to Navy and Marine Corps weapon system platforms in the areas of mechanical drive transmission technologies, materials science technologies, high energy processing technologies, and repair technology.

Point of Contact:  
Mr. Henry Watson  
Institute for Manufacturing and Sustainment  
Technologies  
ARL Penn State  
P.O. Box 30  
State College, PA 16804-0030  
(814) 865-6345  
FAX: (814) 863-1183  
hew2@psu.edu

---

### **National Network for Electro-Optics Manufacturing Technology**

The National Network for Electro-Optics Manufacturing Technology (NNEOMT), a low overhead virtual organization, is a national consortium of electro-optics industrial companies, universities, and government research centers that share their electro-optics expertise and capabilities through project teams focused on Navy requirements. NNEOMT is managed by the Ben Franklin Technology Center of Western Pennsylvania.

Point of Contact:  
Dr. Raymond V. Wick  
National Network for Electro-Optics Manufacturing Technology  
One Parks Bend  
Box 24, Suite 206  
Vandergrift, PA 15690  
(724) 845-1138  
FAX: (724) 845-2448  
wick@nneomt.org

### **Gulf Coast Region Maritime Technology Center**

The Gulf Coast Region Maritime Technology Center (GCRMTC) is located at the University of New Orleans and focuses primarily on product developments in support of the U.S. shipbuilding industry. A sister site at Lamar University in Orange, Texas focuses on process improvements.

Point of Contact:  
Dr. John Crisp, P.E.  
Gulf Coast Region Maritime Technology Center  
University of New Orleans  
College of Engineering  
Room EN-212  
New Orleans, LA 70148  
(504) 280-5586  
FAX: (504) 280-3898  
jncme@uno.edu

### **Manufacturing Technology Transfer Center**

The focus of the Manufacturing Technology Transfer Center (MTTC) is to implement and integrate defense and commercial technologies and develop a technical assistance network to support the Dual Use Applications Program. MTTC is operated by Innovative Productivity, Inc., in partnership with industry, government, and academia.

Point of Contact:  
Mr. Raymond Zavada  
Manufacturing Technology Transfer Center  
119 Rochester Drive  
Louisville, KY 40214-2684  
(502) 452-1131  
FAX: (502) 451-9665  
rzavada@mttc.org

# Appendix G

## *Completed Surveys*

---

As of this publication, 118 surveys have been conducted and published by BMP at the companies listed below. Copies of older survey reports may be obtained through DTIC or by accessing the BMPnet. Requests for copies of recent survey reports or inquiries regarding the BMPnet may be directed to:

Best Manufacturing Practices Program  
4321 Hartwick Rd., Suite 400  
College Park, MD 20740  
Attn: Mr. Ernie Renner, Director  
Telephone: 1-800-789-4267  
FAX: (301) 403-8180  
ernie@bmpcoe.org

---

<b>1985</b>	Litton Guidance & Control Systems Division - Woodland Hills, CA
<b>1986</b>	Honeywell, Incorporated Undersea Systems Division - Hopkins, MN (Alliant TechSystems, Inc.) Texas Instruments Defense Systems & Electronics Group - Lewisville, TX General Dynamics Pomona Division - Pomona, CA Harris Corporation Government Support Systems Division - Syosset, NY IBM Corporation Federal Systems Division - Owego, NY Control Data Corporation Government Systems Division - Minneapolis, MN
<b>1987</b>	Hughes Aircraft Company Radar Systems Group - Los Angeles, CA ITT Avionics Division - Clifton, NJ Rockwell International Corporation Collins Defense Communications - Cedar Rapids, IA UNISYS Computer Systems Division - St. Paul, MN (Paramax)
<b>1988</b>	Motorola Government Electronics Group - Scottsdale, AZ General Dynamics Fort Worth Division - Fort Worth, TX Texas Instruments Defense Systems & Electronics Group - Dallas, TX Hughes Aircraft Company Missile Systems Group - Tucson, AZ Bell Helicopter Textron, Inc. - Fort Worth, TX Litton Data Systems Division - Van Nuys, CA GTE C <sup>3</sup> Systems Sector - Needham Heights, MA
<b>1989</b>	McDonnell-Douglas Corporation McDonnell Aircraft Company - St. Louis, MO Northrop Corporation Aircraft Division - Hawthorne, CA Litton Applied Technology Division - San Jose, CA Litton Amecom Division - College Park, MD Standard Industries - LaMirada, CA Engineered Circuit Research, Incorporated - Milpitas, CA Teledyne Industries Incorporated Electronics Division - Newbury Park, CA Lockheed Aeronautical Systems Company - Marietta, GA Lockheed Corporation Missile Systems Division - Sunnyvale, CA Westinghouse Electronic Systems Group - Baltimore, MD General Electric Naval & Drive Turbine Systems - Fitchburg, MA Rockwell International Corporation Autonetics Electronics Systems - Anaheim, CA TRICOR Systems, Incorporated - Elgin, IL
<b>1990</b>	Hughes Aircraft Company Ground Systems Group - Fullerton, CA TRW Military Electronics and Avionics Division - San Diego, CA MechTronics of Arizona, Inc. - Phoenix, AZ Boeing Aerospace & Electronics - Corinth, TX Technology Matrix Consortium - Traverse City, MI Textron Lycoming - Stratford, CT

- 
- 1991**      *Resurvey of Litton Guidance & Control Systems Division* - Woodland Hills, CA  
Norden Systems, Inc. - Norwalk, CT  
Naval Avionics Center - Indianapolis, IN  
United Electric Controls - Watertown, MA  
Kurt Manufacturing Co. - Minneapolis, MN  
MagneTek Defense Systems - Anaheim, CA  
Raytheon Missile Systems Division - Andover, MA  
AT&T Federal Systems Advanced Technologies and AT&T Bell Laboratories - Greensboro, NC and Whippany, NJ  
*Resurvey of Texas Instruments Defense Systems & Electronics Group* - Lewisville, TX
- 
- 1992**      Tandem Computers - Cupertino, CA  
Charleston Naval Shipyard - Charleston, SC  
Conax Florida Corporation - St. Petersburg, FL  
Texas Instruments Semiconductor Group Military Products - Midland, TX  
Hewlett-Packard Palo Alto Fabrication Center - Palo Alto, CA  
Watervliet U.S. Army Arsenal - Watervliet, NY  
Digital Equipment Company Enclosures Business - Westfield, MA and Maynard, MA  
Computing Devices International - Minneapolis, MN  
*(Resurvey of Control Data Corporation Government Systems Division)*  
Naval Aviation Depot Naval Air Station - Pensacola, FL
- 
- 1993**      NASA Marshall Space Flight Center - Huntsville, AL  
Naval Aviation Depot Naval Air Station - Jacksonville, FL  
Department of Energy Oak Ridge Facilities (Operated by Martin Marietta Energy Systems, Inc.) - Oak Ridge, TN  
McDonnell Douglas Aerospace - Huntington Beach, CA  
Crane Division Naval Surface Warfare Center - Crane, IN and Louisville, KY  
Philadelphia Naval Shipyard - Philadelphia, PA  
R. J. Reynolds Tobacco Company - Winston-Salem, NC  
Crystal Gateway Marriott Hotel - Arlington, VA  
Hamilton Standard Electronic Manufacturing Facility - Farmington, CT  
Alpha Industries, Inc. - Methuen, MA
- 
- 1994**      Harris Semiconductor - Melbourne, FL  
United Defense, L.P. Ground Systems Division - San Jose, CA  
Naval Undersea Warfare Center Division Keyport - Keyport, WA  
Mason & Hanger - Silas Mason Co., Inc. - Middletown, IA  
Kaiser Electronics - San Jose, CA  
U.S. Army Combat Systems Test Activity - Aberdeen, MD  
Stafford County Public Schools - Stafford County, VA
- 
- 1995**      Sandia National Laboratories - Albuquerque, NM  
Rockwell Defense Electronics Collins Avionics & Communications Division - Cedar Rapids, IA  
*(Resurvey of Rockwell International Corporation Collins Defense Communications)*  
Lockheed Martin Electronics & Missiles - Orlando, FL  
McDonnell Douglas Aerospace (St. Louis) - St. Louis, MO  
*(Resurvey of McDonnell-Douglas Corporation McDonnell Aircraft Company)*  
Dayton Parts, Inc. - Harrisburg, PA  
Wainwright Industries - St. Peters, MO  
Lockheed Martin Tactical Aircraft Systems - Fort Worth, TX  
*(Resurvey of General Dynamics Fort Worth Division)*  
Lockheed Martin Government Electronic Systems - Moorestown, NJ  
Sacramento Manufacturing and Services Division - Sacramento, CA  
JLG Industries, Inc. - McConnellsburg, PA
- 
- 1996**      City of Chattanooga - Chattanooga, TN  
Mason & Hanger Corporation - Pantex Plant - Amarillo, TX  
Nascote Industries, Inc. - Nashville, IL  
Weirton Steel Corporation - Weirton, WV  
NASA Kennedy Space Center - Cape Canaveral, FL  
Department of Energy, Oak Ridge Operations - Oak Ridge, TN

---

**1997**      Headquarters, U.S. Army Industrial Operations Command - Rock Island, IL  
SAE International and Performance Review Institute - Warrendale, PA  
Polaroid Corporation - Waltham, MA  
Cincinnati Milacron, Inc. - Cincinnati, OH  
Lawrence Livermore National Laboratory - Livermore, CA  
Sharretts Plating Company, Inc. - Emigsville, PA  
Thermacore, Inc. - Lancaster, PA  
Rock Island Arsenal - Rock Island, IL  
Northrop Grumman Corporation - El Segundo, CA  
(*Resurvey of Northrop Corporation Aircraft Division*)  
Letterkenny Army Depot - Chambersburg, PA  
Elizabethtown College - Elizabethtown, PA  
Tooele Army Depot - Tooele, UT

---

**1998**      United Electric Controls - Watertown, MA  
Strite Industries Limited - Cambridge, Ontario, Canada  
Northrop Grumman Corporation - El Segundo, CA  
Corpus Christi Army Depot - Corpus Christi, TX  
Anniston Army Depot - Anniston, AL  
Naval Air Warfare Center, Lakehurst - Lakehurst, NJ  
Sierra Army Depot - Herlong, CA  
ITT Industries Aerospace/Communications Division - Fort Wayne, IN  
Raytheon Missile Systems Company - Tucson, AZ  
Naval Aviation Depot North Island - San Diego, CA  
*U.S.S. Carl Vinson (CVN-70)* - Commander Naval Air Force, U.S. Pacific Fleet  
Tobyhanna Army Depot - Tobyhanna, PA

---

**1999**      Wilton Armetale - Mount Joy, PA  
Applied Research Laboratory, Pennsylvania State University - State College, PA  
Electric Boat Corporation, Quonset Point Facility - North Kingston, RI  
NASA Marshall Space Flight Center - Huntsville, AL  
Orenda Turbines, Division of Magellan Aerospace Corporation - Mississauga, Ontario, Canada

---