



Report of Survey Conducted at

**ROCKWELL DEFENSE ELECTRONICS
COLLINS AVIONICS AND
COMMUNICATION DIVISION**

CEDAR RAPIDS, IA

APRIL 1995

BEST MANUFACTURING PRACTICES



Center of Excellence for Best Manufacturing Practices

DISTRIBUTION STATEMENT A
Approved for Public Release
Distribution Unlimited

20011231 065

A&I 02-03-0569

P R E F A C E



During the week of 3 April 1995, a Best Manufacturing Practices (BMP) survey was conducted at Rockwell Defense Electronics, Collins Avionics and Communications Division (CACD) located in Cedar Rapids and Coralville, Iowa. CACD is a world leader in electronic information distribution, processing, and control. Capabilities include communications/information transport; customer support; advanced high frequency information systems; navigation/information collection; advanced concepts; and integrated applications.

CACD has 4000 employees located in two facilities in Iowa and also supports employees at 25 worldwide sites. CACD's FY95 sales figures through May of 1995 stand at \$570M.

Since 1987 when the BMP program first conducted at survey at Rockwell, this company has undergone changes and consolidation, and best practices identified then have evolved into some of the new best practices in this report. One practice has remained constant – that of the relationship between management and employee. This effort is a critical element in Rockwell CACD's success and in its streamlining effort. The High Performance Work System provided the survey team with an excellent example of Rockwell's dedication to remaining competitive in the global market. The system integrates management philosophy and hardware use to create and maintain a continuous flow of high quality products. Efforts such as the Surveillance Through Excellence Program also highlight how Rockwell CACD places considerable emphasis on employee ownership of processes and quality assurance.

BMP surveys are conducted to identify best practices in one of the critical path templates of the Department of Defense (DOD) 4245.7-M, "Transition from Development to Production." This document provides the basis for BMP surveys that concentrate on areas of design, test, production, facilities, logistics, and management. Practices in these areas and other areas of interest are presented, discussed, reviewed, and documented by a team of government engineers and technicians who are invited by the company to evaluate the company's policies, practices, and strategies. Only non-proprietary practices selected by the company are reviewed. In addition to the company's best practices, the BMP survey team also reviews potential industry-wide problems that can be referred to one of the Navy's Manufacturing Technology Centers of Excellence. The results of the BMP surveys are entered into a database for dissemination through a central computer network. The actual exchange of detailed data is between companies at their discretion.

The Best Manufacturing Practices program is committed to strengthening the U.S. industrial base. Improving the use of existing technology, promoting the introduction of enhanced technologies, and providing a non-competitive means to address common problems are critical elements in achieving that goal. This report on Rockwell CACD will provide you with information you can use for benchmarking and is part of the national technology transfer effort to enhance the competitiveness of the U.S. industrial Base.



“CRITICAL PATH TEMPLATES FOR TRANSITION FROM DEVELOPMENT TO PRODUCTION”

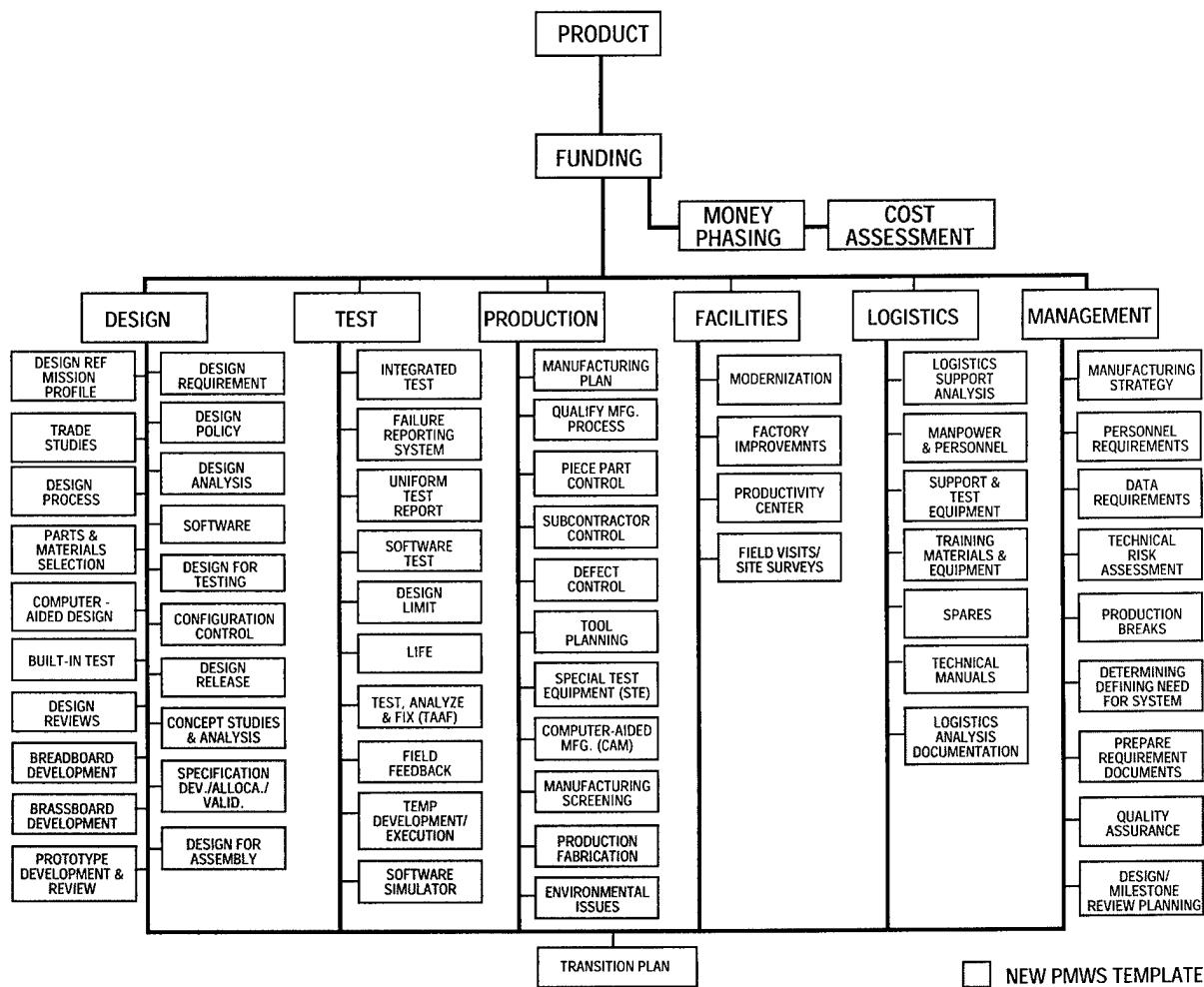

CONTENTS

1. EXECUTIVE SUMMARY

1.1 BACKGROUND.....	1
1.2 BEST PRACTICES	2
1.3 INFORMATION.....	3
1.4 POINT OF CONTACT.....	4

2. BEST PRACTICES

2.1 FUNDING

COST ASSESSMENT

Activity-Based Costing	5
------------------------------	---

2.2 DESIGN

DESIGN POLICY

On-Line PWB Manual	5
--------------------------	---

DESIGN ANALYSIS

Enterprise Product Information Control System	5
Parametric and Vendor Information Database	6

2.3 PRODUCTION

MANUFACTURING PLAN

High Performance Work System	6
------------------------------------	---

PIECE PART CONTROL

Material Advanced Enterprise System Rockwell Operations	7
---	---

SUBCONTRACTOR CONTROL

Variation Reduction Program	8
-----------------------------------	---

DEFECT CONTROL

Test, Repair, and Configuration System	8
--	---

Surveillance Through Excellence Program	9
---	---

PRODUCTION FABRICATION

Automated Conformal Coating Application Process.....	9
--	---

ENVIRONMENTAL ISSUES

Freon Replacement and HAZMAT Program	10
--	----

Solid Waste Environmental Leadership and Learning Team	10
--	----

2.4 FACILITIES

FACTORY IMPROVEMENTS

Robotic Placement Workcell	11
----------------------------------	----

CONTENTS (Continued)

2.5 MANAGEMENT

MANUFACTURING STRATEGY

Enterprise Core Network	11
Pay from Receipt.....	12
Automated Purchase Order System	12

3. INFORMATION

3.1 FUNDING

COST ASSESSMENT

Labor Authorization and Distribution System	13
---	----

3.2 DESIGN

DESIGN ANALYSIS

Statistical Process Control	13
-----------------------------------	----

3.3 PRODUCTION

MANUFACTURING PLAN

Inert Atmosphere Wave Soldering Process	14
---	----

QUALIFY MANUFACTURING PROCESS

High Voltage Power Supply Encapsulation	15
Chip-On-Board/Multi-Chip Module	15

PIECE PART CONTROL

Kit Tracking	16
--------------------	----

COMPUTER-AIDED MANUFACTURING

Electronic Work Instructions	16
------------------------------------	----

3.4 FACILITIES

FACTORY IMPROVEMENTS

Paperless Work Flow for Electronic Maintenance Work Requests	17
--	----

3.5 MANAGEMENT

PERSONNEL REQUIREMENTS

Human Resources Paperless Workflow System	17
Commodity Teams	17

DATA REQUIREMENTS

Electronic Data Interchange	18
Program Planning and Tracking Tool	18
COINS System	19
Business Information System	20

CONTENTS (Continued)

3.5 MANAGEMENT (Continued)

QUALITY ASSURANCE

Enhanced Inspection Information System	21
--	----

APPENDIX A - TABLE OF ACRONYMS	A-1
APPENDIX B - BMP SURVEY TEAM	B-1
APPENDIX C - PROGRAM MANAGER'S WORKSTATION	C-1
APPENDIX D - NAVY CENTERS OF EXCELLENCE	D-1
APPENDIX E - NEW BEST MANUFACTURING PRACTICES PROGRAM TEMPLATES	E-1
APPENDIX F - COMPLETED SURVEYS	F-1

FIGURES & TABLES

FIGURES

2-1	Component Variation Reduction Recurring Chart For Vendor Data Communications	8
3-1	COINS System	19
3-2	Business Information System Architecture	20

TABLES

2-1	Wave Soldering Process Qualification Test Result Summary	10
2-2	Ozone Depleting Chemicals (Cedar Rapids)	11
2-3	Ozone Depleting Chemicals (Coralville)	11

SECTION 1

EXECUTIVE SUMMARY

1.1 BACKGROUND

Rockwell Collins Avionics and Communication Division (CACD) is a world leader in electronic information distribution, processing, and control. In its communications effort, Rockwell CACD's capabilities include air, land, sea, satellite, C³I, and ECCM efficiencies; information distribution systems, and displays. On the navigational end, CACD produces cockpit and flight management systems, integrated avionics, and advanced programs in both communication and navigation. These capabilities translate into the business applications of communications/information transport, customer support, advanced high frequency information systems, navigation/information collection, advanced concepts, and integrated applications. CACD's almost 4000 employee workforce is headquartered in Iowa, with one facility in Cedar Rapids covering 596,000 square feet, and another in nearby Coralville encompassing 140,000 square feet. However, the CACD supports employees at more than 25 worldwide sites. CACD's FY95 sales figures through May of 1995 stand at \$570M.

In 1987, when the Best Manufacturing Practices (BMP) survey team first visited Rockwell in Cedar Rapids, Iowa, the company was known as Collins Defense Communications, and the survey highlighted best practices such as a Shared Database Between Engineering and Operations, and Design-to-Cost efforts. Since that time, this company has undergone changes and consolidation, and has seen the defense industry experience much the same. Although those best practices are still at Rockwell today, they have – perhaps more importantly – provided a substantial foundation for the development and growth of the new best practices in this report.

Even when the BMP survey team visited Rockwell in the late 1980s, a strong relationship between management and employees was evidenced by high employee motivation and a strong, positive attitude. This relationship provided a good infrastructure for the streamlining effort that Rockwell has undergone, as communication between these parties is still a best practice at CACD. There is a strong undercurrent of constructive change, supported by a collective, positive attitude. "Doing more with less people" does not constitute an obstacle to CACD, it represents a challenge and one that Rockwell is meeting. The company remains outward-looking – continually open to new ideas and technology – and is a strong advocate for technology transfer.

There are two programs that highlight this technology transfer philosophy – the Sequential Electrochemical Reduction Analysis (SERA) Solderability Assessment Technology Program, and the Reduced Oxide Soldering Activation (ROSA™) Soldering Technology Program. The SERA process determines the type and degree of oxidation present on a solder surface by electrochemically removing the oxides from the solder surface and measuring the voltage/charge associated with the removal process. The use of this technology has facilitated the reduction of solder defects in a production environment. ROSA™ is a new method of removing oxidation of copper, tin, and tin-lead surfaces through electrochemical reduction for use in mass soldering processes. This technology has been shown to be a practical means of ensuring solderability without the use of CFC solvent materials for removing flux residue.

Perhaps no other best practice provided the survey team with a better collective example of CACD's overall determination to maintain its worldwide competitive edge than the High Performance Work System (HPWS). The HPWS integrates management philosophy and hardware use in four major areas of Product Support Teams development; work culture and management's approach to transition; work process redesign; support functions realignment; and renewal activities. Through the application of tracking systems to monitor volume requirements and schedules, the HPWS provides a valuable resource for CACD's management and personnel to create and maintain a continuous flow of high quality products. Likewise, core processes can be restructured, redesigned, and enhanced. Just as importantly, HPWS supports the work transition at CACD, instituted through a customer-focused, empowered workforce roadmap. CACD continually re-examines the HPWS and its effect on the overall quality of work, and those lessons learned are integrated into the existing system for continual renewal of HPWS efforts. This program represents one of the most critical aspects of CACD's current success and provides the basis for its continuation.

Likewise, the Surveillance Through Excellence Program (STEP) supports the concepts behind the HPWS and has provided Rockwell CACD substantial savings in several areas. This program emphasizes employee empowerment by replacing 100% inspection with operator ownership, supported through training and qualification efforts. Since 1991, CACD has realized savings of over \$1.3M through STEP. Those benefits reflect Rockwell's dedication to producing better products at a reduced cost by promoting

employee ownership and pride, both important aspects of the High Performance Work System.

Rockwell CACD is a company making difficult adaptations to the defense industrial base shift, but is doing so successfully through careful application of the systems and philosophies exhibited in the HPWS and through programs such as STEP. These efforts have proven successful as evidenced by the CACD Coralville facility's selection as one of the top 25 finalists in *Industry Week* magazine's fifth annual "Best Plants" contest in 1994. The contest targets companies who exemplify manufacturing excellence and are committed to world class competitiveness and continuous involvement. By implementing and supporting forward-thinking programs, Rockwell CACD will maintain and expand its share in the world marketplace and continue to share best practices such as those in this BMP report with the rest of industry and government.

1.2 BEST PRACTICES

The BMP survey team identified the following best practices at Rockwell CACD.

Item	Page
Activity-Based Costing	5
Rockwell CACD applies Activity-Based Costing techniques to several automated assembly processing centers in its Coralville manufacturing facility.	
On-Line PWB Manual	5
CACD developed a paperless design tool to help engineers transition designs into hardware. CACD's Enterprise Product Information Control System allows easy access to enterprise product data for all personnel.	
Enterprise Product Information Control System	5
The Enterprise Product Information Control System provides easy access to enterprise product data such as mechanical and electrical CAD data, analytical data, product documentation and specification material, program schedules, and life cycle product information to all personnel from design engineers to production operations.	
Parametric and Vendor Information Database	6
CACD developed the Parametric and Vendor Information Database to facilitate the use of preferred parts and address associated problems with numerous duplicate and similar-to-part numbers used throughout the company.	

Item	Page
High Performance Work System	6
The High Performance Work System at CACD incorporates management principles and hardware/software usage to allow the company to consistently produce high quality products.	
Material Advanced Enterprise System Rockwell Operations	7
This system is a unique material verification record system developed by CACD to provide an inspector the ability to view material specifications and drawings and pertinent verification information on-line.	
Variation Reduction Program	8
Rockwell CACD initiated a Variation Reduction Program in 1993, replacing subcontractor surveys to verify product quality.	
Test, Repair, and Configuration System	8
Rockwell CACD developed a PC network-based system to capture process control data, and it will replace current capabilities with intuitive, easy-to-use, operator interfaces.	
Surveillance Through Excellence Program	9
The Surveillance Through Excellence Program replaces inspection activity with operator quality inspection and emphasizes building quality products without non-value added operations, processes, queues, and rework.	
Automated Conformal Coating Application Process	9
Coralville uses an alternate conformal coating process that satisfies environmental requirements while realizing many other advantages.	
Freon Replacement and HAZMAT Program	10
CACD surpassed EPA requirements in hazardous material consumption reduction from 1991 to 1992, with a reduction of 1,471,650 pounds of all toxic chemical consumption, and an 885,702-pound reduction of freon and trichloroethane alone.	
Solid Waste Environmental Leadership and Learning Team	10
CACD's Solid Waste Environmental Leadership and Learning Team has shown that being environmentally conscious does not result in expenses, but rather decreases costs by avoiding the purchase of reusable items and reducing landfill costs.	

Item	Page	Item	Page
Robotic Placement Workcell	11	High Voltage Power Supply Encapsulation	15
Rockwell CACD manufactured its own pick-and-place machine to produce CCAs with a large number of part numbers and numerous packaging styles.		To accommodate the MILSTAR program that involved production of 24 high voltage power supplies and three spares, CACD developed a process to encapsulate the power supply with no voiding; a facility was built to meet production requirements; and the product was delivered on schedule to the customer.	
Enterprise Core Network	11	Chip-on-Board/Multi-Chip Module	15
CACD developed an Enterprise Core Network vision to address problems of multiple computer networks, platforms, and mail systems; a lack of connectivity between hardware platforms; limited physical infrastructure; and a shift of network usage growth.		CACD developed chip-on-board manufacturing processes in an attempt to miniaturize an oscillator module used extensively throughout CACD products.	
Pay from Receipt	12	Kit Tracking	16
CACD's new accounts payable process electronically matches the purchase order with the receiving document, and the system completely eliminates supplier invoices from the payment process.		The Coralville facility developed a more automated system to identify part shortages, stage partial kits, match back orders with partial issues, and provide accurate production control.	
Automated Purchase Order System	12	Electronic Work Instructions	16
The Automated Purchase Order System uses expert decision making software for automatically processing high volume, low value purchase orders.		CACD now uses an electronic system for work instructions to replace the cumbersome and time-consuming manual system.	
1.3 INFORMATION		Paperless Work Flow for Electronic Maintenance Work Requests	17
The following information items were highlighted by the BMP survey team at Rockwell CACD.		CACD developed a paperless work flow for electronic Maintenance Work Requests.	
Item	Page	Human Resources Paperless Work Flow	17
Labor Authorization and Distribution System	13	Rockwell CACD has created a Paperless Workflow System to electronically process human resources forms.	
Rockwell CACD has initiated automating and redesigning the salaried direct charge labor distribution process.		Commodity Teams	17
Statistical Process Control	13	CACD utilizes cross-functional commodity teams to manage all aspects of key part and material commodities.	
Rockwell CACD maintains that continuous process improvement through statistical process control will enhance its competitive stance in the world marketplace.		Electronic Data Interchange	18
Inert Atmosphere Wave Soldering Process	14	Rockwell CACD began using Electronic Data Interchange in its business functions in 1993 with two trading partners and 3700 transactions. FY95 estimates are for more than 10 trading partners and 10,000 transactions.	
The Montreal Protocol, the availability of inert gas wave soldering technology, and the desire to reduce process maintenance costs drove CACD to implement an inert atmosphere wave soldering process.			

Item	Page	Item	Page
Program Planning and Tracking Tool	18	Enhanced Inspection Information System	21
CACD engineers have developed a computer model of their system engineering processes that imitates the DOD-STD-5000 processes used by Department of Defense system engineers.		Rockwell CACD uses a quality tool called the Enhanced Inspection Information System to monitor quality and continually strive for improvement.	
COINS System	19	1.4 POINT OF CONTACT	
Rockwell CACD has begun using COINS, a client/server-based system, to retrieve computer output to PCs in the company.		For more information on any item in this report, please contact:	
Business Information System	20	Dave Jourdan	
Rockwell CACD's Business Information System is a comprehensive financial reporting system that allows quick and easy access to integrated financial data through a PC-based graphical interface.		Change Facilitator	
		855 35th Street NE	
		M/S 37109	
		Cedar Rapids, IA 37109	
		319-395-3392	

SECTION 2

BEST PRACTICES

2.1 FUNDING

COST ASSESSMENT

Activity-Based Costing

Rockwell CACD applies Activity-Based Costing (ABC) techniques to several automated assembly processing centers in its Coralville manufacturing facility. A separate cost pool is established for each process center, and only products using that automated center absorb its cost. This approach replaces traditional methods based on direct labor and associated overhead, which includes indirect costs derived from operation of the entire factory. The shift to ABC is the result of several factors. For example, high performance work systems and technological advances help significantly reduce the direct labor component of many manufacturing processes. CACD also recognizes that cost absorption based on direct labor can distort true product cost. ABC provides a more accurate measure of cost and asset utilization, and provides information for learning and process improvement.

With ABC, all costs associated with a particular machine or group of machines are pooled together. These cost elements include labor such as operator, engineering, and maintenance personnel; depreciation; tooling and supplies; taxes; calibration and repair; and facility costs. The associated costs are removed from the manufacturing overhead. Cost-per-board rates are derived by dividing the total pool costs by the total number of boards produced. Each process center therefore has a separate rate based on the cost pool and board volume. These rates are contained in the Forward Pricing Rate Agreement which has been worked out and approved locally by the plant's Defense Contracting Activity Site representative.

ABC provides enhanced visibility of true cost drivers, promotes proactive cost reduction rather than reactive performance problem investigations, and simplifies bidding and estimating. Integrated Product and Process Development (IPPD), producibility decision making, and variance analysis are all simplified and improved by using ABC. A continuing drawback to the cost-per-board method of cost absorption, however, is the uniform cost assigned to each board, even though there can be significant variations in board configurations.

2.2 DESIGN

DESIGN POLICY

On-Line PWB Manual

The Advanced Engineering and Core Design Process (AE&CDP) Group at CACD has developed a paperless design tool to help engineers transition designs into hardware. Historically, PWB design, layout, and process information was maintained in hard-copy manuals, data books, or the process owner's memory. No single engineer had copies of all the manuals or information needed and if so, the data was most likely obsolete.

The AE&CDP took advantage of a commercial-off-the-shelf software package to compose an easily distributable, paperless manual. It provides information and guidance on PWB processes, materials and properties, device footprints, workstation library data, design and layout guidelines and rules, and lessons learned.

Developing this on-line PWB manual ensures that all designers and engineers use the same technology, design rules and that any added features or changes can have instant distribution. The manual is a living document accessible from PCs and workstations.

DESIGN ANALYSIS

Enterprise Product Information Control System

Rockwell CACD developed an Enterprise Product Information Control System (EPICS) to help it function in a concurrent engineering environment and maximize the applicability of existing designs and data. EPICS provides easy access to enterprise product data such as mechanical and electrical CAD data, analytical data, product documentation and specification material, program schedules, and life cycle product information to all personnel from design engineers to production operations. This system will increase efficiency by eliminating timely documentation research or the use of incorrect, outdated information.

CACD assembled an EPICS team to select and implement a Product Data Management software package in this concurrent engineering effort. This cross-functional team,

consisting of personnel from all areas of product development, established a three-step process in this project. The first step was highlighted by on-line access to drawings and specifications, the second step with visibility to product development status through all phases, and the third by facilitating IPPD through improved communication.

The EPICS system is built around Hewlett-Packard's WorkManager which provides controlled access to data during product design, version control of data and bill of materials, revision control upon formal release, automated review and sign-off of product changes, and storage and retrieval of data from the EPICS electronic data repository. EPICS helps the work flow by providing controlled storage, access, and management for all enterprise product data. The flow from design to production is flexible to support different production environments such as military or commercial. The system allows test engineers easy accessibility to schematics for troubleshooting without the difficulties associated with finding the latest revisions and changes. Design engineers also have easy access to test data for future redesign efforts if/when required.

Cost benefits and waste reductions include reusability of data and designs while replacing paper and manual processes for documentation and consequent configuration. Labor costs will be reduced through less clerical work and less time required to locate the latest revision of a drawing or product data. A 6% cost savings will be realized on each IPPD effort. A 30% reduction in cost in customer documentation will also be achieved. Configuration management, technical publications, purchasing, and production operations have also seen cost savings.

Parametric and Vendor Information Database

CACD developed the Parametric and Vendor Information Database (PVID) to facilitate the use of preferred parts and address associated problems with numerous duplicate and similar-to part numbers used throughout the company. The need to reduce the number of parts used at CACD was critical because material purchases and the parts database maintenance required a large percentage of the overall corporate cash flow.

CACD recognized that a main cause of this problem was due to lack of visibility on existing part numbers in use. Based on these concerns, the system needed to provide a way to find existing parts, a parts data repository, a vehicle for classifying parts, and a framework for a tools-based parts selection process.

PVID currently contains data on over 216,000 part numbers in the system. Over 1.8 million parameters of associated part data, including part classification (Preferred, Non-Preferred, or Obsolete), supplier status, and selected func-

tional parameters endemic to each technology also reside in this database.

PVID is accessible through either a PC or UNIX workstation and contains three primary features:

- *Cpn search* - This function allows a user to locate any CACD or military-required part number in the system and view its parameters.
- *Parametric search* - This function allows a user to find parts in the system that match user-specified parametric values.
- *VpnCpn Cross-reference* - This function allows a user to enter a CACD, military-required, or vendor part number, and PVID will locate all counterparts.

A new Windows version of PVID has an intuitive interface and on-line help, and supports part cost data on over 56,000 active part numbers as well as on-line visibility of component specification for many listed part numbers.

Since 1993, PVID use by the engineering community has increased 157%, with a corresponding 11% reduction in active part numbers. CACD maintains that this reduction can be attributed in part to expanded use of PVID and a Division-wide engineering goal to maximize preferred part content in current designs. Overall, PVID promotes parts standardization by facilitating the use of preferred parts. In addition to the benefits seen in parts reduction, the time to develop a stable parts list has been reduced, a result directly attributable to the search capabilities of PVID.

2.3 PRODUCTION

MANUFACTURING PLAN

High Performance Work System

Rockwell CACD's HPWS was designed to respond to the changing marketplace, a downsizing defense industry and most importantly, to help CACD become more globally competitive. This system incorporates management principles and hardware/software usage to allow CACD to consistently produce high quality products. It integrates development of Product Support Teams (PSTs), transition of the work culture and management approach, redesign of the work process alignment of support functions, and renewal activities into a cohesive, continuous flow operation.

PSTs at CACD are cross-functional, product-oriented teams. Functionally, the PST supports the Natural Work Groups, such as process-oriented teams in manufacturing. The PST is comprised of core members such as a facilitator, coordinator, Quality Control Engineer, Manufacturing Electrical Engineers, Industrial Engineers, and Industrial Engineering (IE) Technicians. These PSTs are empowered to make decisions regarding the design and manufacture of a product and are driven by a common goal of customer satisfaction.

One of the tools accessible to the PST is a highly integrated MRP system which provides manufacturing flow information from upper management to the working level operator. CACD's MRP system has evolved from the Distributed Manufacturing Control System to the Product Inventory Optimization System, which has provided the PSTs a powerful tool to plan and control manufacturing.

The PSTs are supported by a number of key functions such as reliability engineers, purchasing, quality assurance, and configuration management. One of the key goals of the HPWS is to integrate and align these support functions within the PSTs. This alignment would provide the PSTs real-time data and support to allow them to be more fully functional. As a part of the alignment process, CACD has evaluated the need for increased delegation of authority, reward systems for the support functions, and the potential redesign of the support function itself. CACD has found that the actual alignment of these support functions is succeeding as the PSTs mature.

One of the principal thrusts in the HPWS is the transition of the work culture at CACD. To support this successful transition, management at CACD has developed an organizational/ redesign roadmap, emphasized and instituted a customer focus, developed and deployed a vision, and transitioned from control management to commitment management through empowered work teams. This concerted effort by management represents a critical component to the overall successful work-culture transition.

The redesign of work processes is a pivotal component of the HPWS. CACD's approach to redesigning processes focuses on developing and empowering teams around core processes. Teams are supported and trained using both internal and external consultants. Examples of these teams include the Product Line Support Cost Reduction Team, Factory-of-the-Future Team, Commercialization Team (addressing Rockwell's response to the Perry initiative), Project Planning and Tracking Team, Test Equipment Cost Study Team, as well as specific teams to redesign and improve a variety of other processes.

HPWS renewal activities center on continuous training and skills expansion of the work force, process redesign, and constant research for new methods to improve HPWS' implementation and use.

There are a number of examples demonstrating how HPWS improved cycle times, cost, efficiency, quality, and schedules. For example, the Receiving Area Team at Coralville was structured and empowered for total responsibility in receipts, inspections, and stock preparation. This empowerment allowed employees to change processes that improved efficiency by 25% and improved cycle time by 40%. Another area of great success is in Coralville's Recycling Program. This team, led by an empowered maintenance employee, has created processes that have significantly reduced the amount of material sent to land-

fills and have created a community partnership through Goodwill Industries.

The Precision Light Global Positioning Satellite Receiver production line provides an example of HPWS's overall applications. Volume requirements, scheduled cost reductions, and aggressive schedules were providing significant roadblocks at Rockwell. Through the HPWS, operators and test technicians were able to provide significant input to the design of the product and its related processes, create a continuous-flow, shop-floor control system, and streamline the test operations using SPC techniques.

CACD maintains there were many lessons learned from instituting the HPWS. Management commitment is critical, an example of which is in the up-front management-labor partnership at Coralville which significantly assisted in key successes. HPWS had to be integrated into all aspects of the company to include organizational structure, management systems, training systems, reward systems, and the technology applied. In addition, a structural roadmap that charts out the process of transitioning the culture and empowering teams was pivotal.

PIECE PART CONTROL

Material Advanced Enterprise System Rockwell Operations

The Material Advanced Enterprise System Rockwell Operations (MAESTRO) is a unique material verification record system developed by CACD to provide an inspector the ability to view material specifications and drawings and pertinent verification information on-line. MAESTRO also monitors supplier quality performance, internal manufacturing problems, and past supplier-related problems. In 1993, initiatives by CACD's computer services department and the inspection department in Coralville led to the development of the MAESTRO system. Hosted with a Paradox application on an OS2 operating system, MAESTRO has been in operation for over a year and has replaced the previous manual operations of material verification, tracking, and logging forms.

Unique features of this system include on-line inspection results review; detailed defect information and lot disposition tracking; stock reinspection result monitoring; search capability on inspection records by supplier, part number, or purchase order folder; note placement by supplier, part number, or purchase order; and inspection and test criteria routing. The system is capable of flagging the inspector when internal manufacturing problems or past supplier-related problems require specific instructions. MAESTRO can then trigger Procurement Quality Assurance personnel when a discrepancy is detected, and automatically signal the supplier for corrective action.

MAESTRO is user friendly and provides sufficient flexibility to evolve with the market-driven inspection needs and process changes.

SUBCONTRACTOR CONTROL

Variation Reduction Program

Rockwell CACD initiated a Variation Reduction Program in 1993, replacing subcontractor (and supplier) surveys to verify their quality systems and product quality. The original program introduced variation reduction as an alternative to rescreening, with a goal to reduce defects to seven parts per million without 100% testing. This program has been developed to help produce a better quality part through less variation of the individual pieces. Variation reduction results in reduced component performance variation and out-of-specification parts, while making product assembly easier and less costly.

The Variation Reduction Program offers unique continuous improvement communications between design engineering and the suppliers with assistance from Commodity Teams, Material Verification, and Procurement Quality Assurance personnel. Key characteristics are selected from specific piece parts, and statistical analysis is performed by either the supplier or by Material Verification to determine the level of variation for that characteristic. Most suppliers maintain SPC data for statistical analysis and appreciate any SPC feedback. The results are plotted and communicated to the supplier and design engineering for decisions on process improvements and possible specification changes. The variable data also provides a footprint for reduced sampling on additional lots received. The cumulative data for each supplier is used as performance measurements of process assessment for best manufacturing practices and manufacturing development initiative programs.

The program was implemented slowly, with free SPC classes offered to the suppliers to help implement variation reduction. Variation reduction began as communication to the suppliers, since no variation reduction requirements were set. There was also no time limit for suppliers to use SPC, but they were encouraged to do so since Rockwell expects six sigma SPC performance (Figure 2-1). Most suppliers were cooperative and welcomed SPC data on their products. In other cases, the Rockwell representative encouraged SPC application by indicating how useful and quick a tool it is.

There are several benefits derived from the Variation Reduction Program. Less labor is required since each lot is sample-tested and not 100% tested; variable data is better than pass-and-fail data; and finally, there is less parts handling and consequently, less damage to the product.

One lesson learned from applying variation reduction is that the program improves communications and corrective action with suppliers. The suppliers know what the prob-

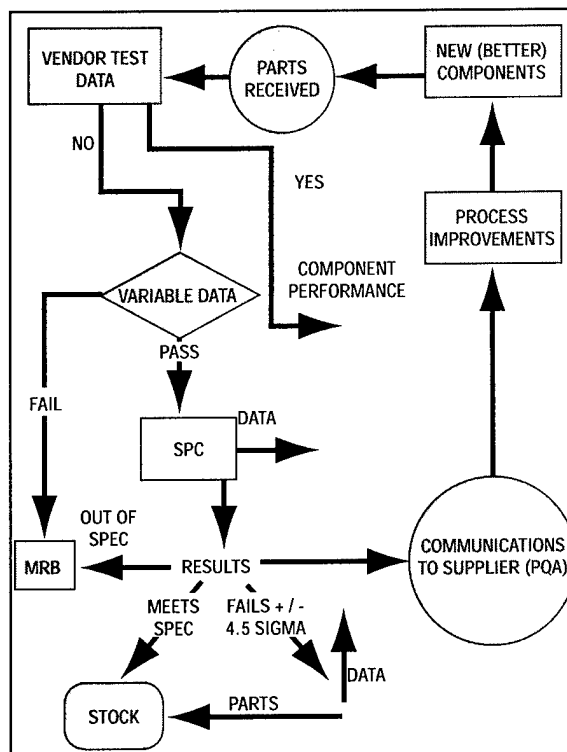

FIGURE 2-1. COMPONENT VARIATION REDUCTION RECURRING CHART FOR VENDOR DATA COMMUNICATIONS

lems are with their products and what the product variants are, so corrective action can be provided. Rockwell has also improved communications with engineering and specifications. For example, CACD determined that although engineering may find a problem they believe to be a supplier problem, it can actually be a specification problem. Overall, the CACD Variation Reduction Program has become a value-added process beyond a rescreening alternative.

DEFECT CONTROL

Test, Repair, and Configuration System

The Reliability and Maintainability Process Team at Rockwell CACD has developed a PC network-based system to capture process control data. The Test, Repair, and Configuration System (TRACS) will replace current capabilities with intuitive, easy-to-use, operator interfaces. The system is customized for each user application, asking appropriate questions of the process operator and capturing only data pertinent to that operation.

Currently, CACD uses four different systems to record most of the inspection, test, and repair information for process control. Three of these are mainframe-based and not user-friendly. All products must use the same screens and databases because modifications would constitute a

long, costly process. The fourth system is dedicated to a single program.

The new system not only replaces the existing systems with a more flexible, user-oriented interface, but has increased the capabilities to convert raw data into information. The TRACS network is a client-server application of commercial off-the-shelf software with a Paradox front end, an Interbase database, and a Paradox/Excel back end. This architecture offers custom screens with Windows conventions, look-up tables, and on-line help. The data is stored in identical but separate databases, allowing customized, real-time manipulation and reporting. An SQL link facilitates data transfer to an Excel spreadsheet for SPC assessments.

TRACS currently focuses on the two capabilities of Automatic Test Equipment data capture and manually entered failure/reject data capture. Future enhancements will create tools and links to other systems to take advantage of the new, more flexible database. One of those tools will be a new Failure Reporting, Analysis, and Corrective Action System to provide feedback to technicians and repair personnel.

Surveillance Through Excellence Program

Rockwell CACD instituted STEP in 1991 to replace inspection activity with operator quality inspection. STEP emphasizes building quality products without non-value added operations, processes, queues, and rework. This goal is supported through operator ownership and a comprehensive training, qualification, and surveillance program.

CACD previously conducted 100% inspection, and defects were returned to appropriate personnel for rework. The operator typically performed to written instructions from quality and manufacturing engineering personnel. The STEP concept realigns personnel into a team, providing ownership and responsibility for the process. It has required commitment from all personnel involved to achieve the goals and continually improve. Using this concept, 100% inspection has been replaced with operator ownership.

Operator training consists of certification to division workmanship standards, rework/repair skills training, and a review of 28 quality methods. For each part number, the operator must successfully complete three consecutive assemblies without a major defect, and maintain a defect rate below 27 defects/10,000. In the rework/repair area, operators are required to rework ten consecutive items with no major defects and no more than two other defects. Any defects found are identified to the operator using Electronic Inspection Information System defect printouts.

Once certification is achieved, a surveillance program is established to maintain quality. Inspection points are minimized, and 100% inspection is reduced to a few random

surveillance points. Operators are issued quality stamps for appropriate inspection identification on routing forms.

Since 1991, CACD has achieved significant results in programs utilizing STEP. For the ARC-190 product team, a cost savings of \$695K was realized, unit build throughput was reduced by three days, and two operator positions were eliminated through attrition. Overall, the company has realized a total savings of \$1.3M. STEP continues to support the High Performance Work System program by promoting employee ownership and pride which ultimately results in better products at a reduced cost.

PRODUCTION FABRICATION

Automated Conformal Coating Application Process

Rockwell CACD, Coralville uses an alternate conformal coating process that satisfies environmental requirements while realizing many other advantages. Since 1993, Rockwell CACD has used a customized, automated conformal coating system from the Nordson Corporation to eliminate problems associated with the traditional spraying application method such as required masking, increased solvent release to the atmosphere, and substantial labor efforts.

Rockwell worked with Nordson to customize the system to Rockwell requirements. The Nordson Select Coat is an in-line workcell comprised of a coating workstation, workcell system controller, and in-line ovens for pre- and post-coating processes. The coating workstation includes a five-axis gantry robot that moves in the x, y, and z directions, as well as 30-degree tilt and a 90-degree incremental rotation. Operations such as coating gun movement, actuation of pneumatic valves, conveyor speed, temperature control, time duration, and overall operations are controlled by the workcell controller.

The system uses laminar flow as the application method. Although similar to spraying, the application method virtually eliminates overspray by using lower pressure (10 psi versus 30 psi). Lower application pressure removes the atomization experienced at higher pressure levels. Because of the ability to control overspray, masking is not required and cleanup is simplified. Labor and cycle time savings are achieved by eliminating two production steps—masking and unmasking. Because the system has a heater, higher viscosity materials can be used with the advantage of being more environmentally friendly since less solvent is required. The application head is also positioned closer to the product (< 0.5-inch) using laminar flow.

This system, which also has an oven preheat and an infrared and convection curing oven, is a complete workcell and has proven to be a good investment for Rockwell CACD production while remaining environmentally friendly.

ENVIRONMENTAL ISSUES

Freon Replacement and HAZMAT Program

From 1991 to 1992, Rockwell CACD surpassed EPA requirements for reduction of hazardous material consumption with a reduction of 1,471,650 pounds of all toxic chemical consumption, and an 885,702 pound reduction of freon and trichloroethane alone. This effort was in response to the EPA voluntary program to reduce emissions of 17 toxic substances. The EPA program called for a 33% emissions reduction by 1992 from the 1988 base level, followed later by a 50% reduction from the 1988 base level.

In continuing support of the Montreal Protocol, CACD has formulated short-term and long-term plans to eliminate ozone depleting substances. The short-term plan includes converting cleaning equipment to alcohol-based cleaning, with a specific focus to convert manufacturing defluxing processes to alternate materials by 1 July 1994. This goal has been met by using a Kyzen SSA cyclic alcohol and DI-water rinse for the in-line and stencil cleaning equipment, a Kyzen HC or Kyzen FC-R cyclic alcohol and DI-water rinse for batch cleaning equipment, and a water soluble flux (Alpha WS360 or Alpha 630) for tinning of parts.

The long-term plan centers on developing a method to clean PWA using water only. CACD must investigate water soluble fluxes and water washable, no-clean fluxes. The time frame

on this plan is to convert both facilities in Iowa to water washable materials and processes by 31 December 1996. A main obstacle is customer acceptance of this process.

CACD's Inert Atmosphere Wave Soldering process qualification also established goals to identify a low residue flux with fluxing performance equal to RMA flux, and to change from a CFC system to an aqueous cleaning system for removing residues with equal to or better than RMA soldered assemblies' cleanliness levels. The test methodology to be used was to meet MIL-STD-2000A, follow the Navy memorandum that adds additional tests, and to meet internal CACD requirements. Test results are shown below (Table 2-1).

The test results met MIL-STD-2000A, Appendix A requirements as well as all other requirements; therefore, the wave soldering process was qualified. A total of 40 MIL-STD-2000A and 500 non-MIL-STD-2000A processes have been converted.

Solid Waste Environmental Leadership and Learning Team

The Solid Waste Environmental Leadership and Learning Team at CACD has shown that being environmentally conscious does not result in expenses, but rather decreases costs by avoiding unneeded purchase of items, and reducing landfill costs. The team has spread its charter of developing, implementing, and championing recycling and reuse of

TABLE 2-1. WAVE SOLDERING PROCESS QUALIFICATION TEST RESULT SUMMARY

<i>Test</i>	<i>Process Requirement</i>	<i>Kester 951 Result</i>
SIR	5x10 ⁸ ohms minimum	Vendor B24: 5X10 ⁹ ohms IPC B24: 1X10 ¹⁰ ohms CACD B24: 1X10 ¹² ohms CACD B36: 1X10 ⁹ ohms
Corrosion	None allowed	QPL qualified flux
Halide content	None allowed	QPL qualified flux
Ionic cleanliness	10 µg/in ² maximum	IPC: 8.00 µg/in ² CACD: 1.33 µg/in ²
Visual inspection	No electromigration allowed	None observed
Design of experiments investigation	Minimum number of defects	Optimum flux per design of experiments
Thermogravimetric Analysis	Minimum loss in Preheat Minimum loss at Wave	Optimum flux Optimum flux
Humidity	Individual component specification	No failures
Electrical	Individual component specification	No failures
Ion chromatography	Equivalent to RMA flux	Acceptable
Thermal cycling	Individual component specification	In progress (no failures to date)
Wetting balance	Equivalent to RMA flux	Acceptable
TSD Division data	Military production build	6 months of production with no reliability problems

solid waste. This effort includes recycling 19 items, reclaiming 15 others, and returning still others to the originating vendor. The results of the team's efforts can be shown in the solid waste reduction from 1992 to 1994 of 213,277 pounds.

Paper products that cannot be recycled are chopped, mixed with coal, and burned at the power plant as fuel cubes. This process also reduces the emissions of burning high sulfur content coal. CACD contracts with Goodwill Industries to sort trash, and sort and return recyclables. An Environmental Recycling Cost Analysis of the Coralville operations highlights an annual expense of \$63K with a benefit of over \$104K, representing a net gain of more than \$41K annual cost avoidance.

Similarly, there is a reduction of ozone depleting chemicals such as those highlighted below.

TABLE 2-2. OZONE DEPLETING CHEMICALS (CEDAR RAPIDS)

	1991	1992	1993	1994	1995	Total
<i>CFC-113</i>						
Pounds Used (K)	55	46	42	24	0	167
Reduction 91-95		16%	24%	57%		
Methyl Chloroform (1,1,1-TRI)						
Pounds Used (K)	35	19	27	24	5*	110
Reduction 91-95		45%	22%	32%	86%	
*for 3 months						
Combined	90	65	69	48	5	277
Reduction, 91-95		27%	23%	47%	95%	

TABLE 2-3. OZONE DEPLETING CHEMICALS (CORALVILLE)

	1989	1990	1991	1992	1993
Methyl Chloroform (1,1,1-TRI)					
Pounds Used (K)	32.2	23	18	16.7	13.9
Reduction, 89-93		29%	62%	67%	80%

2.4 FACILITIES

FACTORY IMPROVEMENTS

Robotic Placement Workcell

Rockwell CACD manufactured its own pick-and-place machine to produce CCAs with a large number of part numbers and numerous packaging styles. Prior to the development of the Robotic Placement Workcell, Rockwell manually placed many otherwise machine-placeable surface mounted devices because the commercial market could not accommodate assembling CCAs with approximately 1000 part numbers and various package styles.

There was also a very low production rate for these CCAs.

Rockwell obtained commercial items and integrated them into a pick-and-place machine, called the Robotic Placement Workcell. These items included Yaskawa's Robotworld RW-20 platform; Flextec elevator servers (custom); Flextec assembly stations and conveyors (custom); Applied Robotics XC-1 Tooling XChange system; an acuity imaging vision system; CCD cameras, framegrabber, and precision optics; tooling plates for reeled or bulk parts in matrix trays; reeled parts (8, 12, 16mm) when available; chiptrays for bulk parts' matrix trays; vacuum tooling for six nozzle styles; and workcell software.

Rockwell CACD has realized several benefits from developing and using its Robotic Placement Workcell. Parts are automatically placed instead of manually, especially parts that have geometric limitations. The number of different types of parts that can be automatically placed has increased to 500 part numbers. The time to place each part has been reduced with the machine, and the no-touch surface mount placement throughput has been increased from the previous 4000 to 8000 components per day.

2.5 MANAGEMENT

MANUFACTURING STRATEGY

Enterprise Core Network

Motivated by downsizing and merging divisions in the early 1990s, CACD quickly developed an Enterprise Core Network (ECN) vision to address multiple computer networks, platforms, and mail systems; a lack of connectivity between hardware platforms; limited physical infrastructure; and network usage growth. A cross-functional team was formed to develop an ECN conceptual plan in March 1992. A comprehensive user specification was produced; a conceptual approach was finalized and confirmed, and implementation was initiated in June 1993.

Key elements of the ECN infrastructure were based on industry standards employing FDDI ring layout, CISCO routers, Synoptics hubs, Ethernet subnets, UNIX-based servers, TCP/IP protocol, T1 Lines, smart diagnostics, and HP Open View Network Manager and Synoptics Optivity. ECN features included e-mail on UNIX file servers and CC:Mobile for remote dial-in, Microsoft Word and WordPerfect word processing, Excel and Quattro Pro spreadsheets, Paradox and FoxPro databases, MS Project management, access to UNIX functionality from PCs thru FTP and Telnet, and global UNIX Servers to facilitate client-server applications.

Current year initiatives include a security system for full Internet access while protecting internal data, full remote access by CACD personnel, and encryption service for secure transmission of proprietary data. Future enhancements include PC software configuration standardization,

cross-functional capacity planning, and desktop video conferencing.

CACD's sound approach—designing and implementing a computer network that works for the enterprise—has provided robust service to its 2600 PCs and over 3000 users. All features to date have been delivered with a high degree of satisfaction, with continuous growth anticipated. Over the past 18 months, there has been no work stoppage as a result of ECN hardware failures. The ECN configuration is set to take CACD into the year 2000.

Pay from Receipt

CACD's new accounts payable process electronically matches the purchase order with the receiving document, and the system completely eliminates supplier invoices from the payment process. The Pay From Receipt (PFR) process is now standard for parts and material procurement at Rockwell CACD.

Rockwell determined that most companies pay suppliers by matching the purchase order (what to buy) with the receiving document (what is received) with the invoice from the supplier (what is delivered). These documents address the same type of data, which leads to errors. It was determined that the supplier invoice added no value to the process, and therefore was eliminated. Without this function, the supplier did not need to submit invoices; CACD did not input invoices into a database, resolve problem invoices, or store invoices.

The PFR process was implemented in phases—each phase consisting of a selected number of suppliers. A brochure announcing the new PFR process to suppliers was created and distributed, and 1200 suppliers were added to the PFR process between April and July 1993. It was implemented for all production part suppliers by November 1993. Cost of implementation was \$58K.

This major business change has provided dramatic savings in administrative costs while maintaining timely pay-

ments to the supplier and the integrity of the procurement process. The Accounts Payable Department has been able to perform the new payment process with five employees instead of 15. The cost per document (including information systems cost) has been reduced from \$8.00 to \$3.00. The PFR process has placed CACD in-house accounting staff costs reductions at a world-class level in accordance with data reported in the Commercial/Government Accounting Function Cost Comparison study by Hackett, 1992, *Journal of Accountancy*, October, 1993.

Automated Purchase Order System

Rockwell CACD created an expert decision-making program to replace the manual decision-making function of the purchase order process. Called the Automated Purchase Order System, or APOS, this new system uses expert decision making software for automatically processing high-volume, low-value purchase orders.

Approximately 85% of all purchase orders at CACD were for less than \$10K. Nearly all these purchase orders were characterized as not requiring complex negotiations and decision making, yet absorbed high administrative costs for non-value added activities under the manual process. Rockwell CACD generated a detailed process flow to fully describe the manual purchase order process and determine the type of activities that could be eliminated and/or automated. This analysis provided the basis for developing APOS.

The system was implemented in 1993 with selected commodities and continued to expand through 1994 to cover nearly all high-volume, low-value purchase orders. Manual operations have been eliminated. The printing of traveling requisitions has been eliminated and input errors have been reduced. Procurement cycle time has been reduced from three days to less than one day. The new APOS system has allowed more effort to be devoted to Commodity Team/Supplier alliance development.

SECTION 3

INFORMATION

3.1 FUNDING

COST ASSESSMENT

Labor Authorization and Distribution System

Rockwell CACD has initiated automating and redesigning the salaried direct charge labor distribution process for enhanced efficiency. A multifunctional steering committee was established in 1991, followed in 1992 by a multifunctional user group/team. The user team has solicited grassroots input from all functional direct charge organizations on difficulties experienced in the past and solicited recommendations for changes. The processes have been flowcharted and the associated costs identified.

The current Labor Authorization and Distribution System (LADS) is user-developed, totally process-automated, paperless, on-line and real time, and client/server or PC/network-based. The system is being implemented in five phases. Phase I and II have been completed for engineering support work orders and work authorizations. Phase III for recording work performed is in process and will be completed by the end of FY95. Phase IV will be completed by the end of FY96 and Phase V will be completed after that time.

The order entry process has been implemented. Order-related accounting information is linked to the prime order number, and the process accommodates generation of orders from "like" information. Order numbers are generated by the system. Status of orders is available on-line. All approvals are performed on the system with the capability of assigning temporary deputies for approvals. Messages are automatically generated for the approval agent, notifying him of pending approval actions. There is no administrative processing of paper involved with the process. Using LADS, the order entry time has been reduced from an average of four days to four hours.

The work authorization process has also been implemented. Authorization can be at the team level as well as at the individual level, and there is an automatic link between the work order number and the work authorization data. The system automatically performs an on-line check of the validity of authorization. This effort has produced significantly fewer errors in the information.

The labor distribution process is ongoing; however, once implemented, the distribution, processing, and filing of manual cards will be eliminated. Virtually all errors and the

resulting error correction cycle will be eliminated since timing, input, or legibility issues will be eliminated. The manual processing of cards will be eliminated. Twenty-eight minutes of administrative time per week will be saved for every direct-charge employee. The current Phase III plans include enhancing the PC-based sidefile software to provide for on-line submittal of labor distribution cards, and an on-line signature capability by the card approvers by providing an on-screen card image. The system will also be expanded to accommodate 1000 users.

3.2 DESIGN

DESIGN ANALYSIS

Statistical Process Control

Rockwell CACD asserts that continuous process improvement through SPC is a critical part of its business future, and therefore maintains SPC objectives to provide leadership for continuous improvement on product quality, reliability, and service to both internal and external customers.

CACD uses SPC in several functional areas such as design, procurement, material verification, warehouse stock issuing, assembly, test, and shipping. Design engineering establishes a baseline database during the design phase. Goals are determined to help drive improvements and identify points where improvements have the greatest impact on first time success. Tools and resources such as Design of Experiments (DOE), Monte Carlo simulators, and six sigma scorecards are provided for predictability of first-time success. Upon determining design robustness, tasks and tools within sub-processes are identified to improve first-time success.

Procurement personnel encourage SPC use at supplier facilities by highlighting potential applications for SPC to gain control over processes, and CACD offers free SPC classes to its suppliers. Additionally, CACD Procurement Quality Assurance, in conjunction with Engineering, is reducing test throughput at suppliers by using SPC data to reduce and eliminate temperature testing. CACD also conducts annual visits to suppliers to monitor SPC and update benchmarking information. All material verification data taken is communicated to suppliers.

SPC is also applied in warehouse stock issuing. Electronic balances are used to count components within material automated warehouses. Operators check their individual scales daily with a standard weight, and plot the scale

readings on individual charts. If the reading is outside of established control limits, operators perform a calibration process with the scale software. This process reduces inventory and issuing errors.

CACD has used SPC in the assembly process area with great success. For example, using DOE, SPC has helped CACD select the best suppliers, metals for applicators, and stencils for use in the surface mount preparation area. A series of four DOE was also used to investigate optimization of waterwash cleaning equipment, the results of which provided the basis for cleaning system settings. It also resulted in a major resistor vendor changing the curing process to yield better marking permanency. DOE has helped Rockwell CACD to optimize the viscosity of conformal coating, and SPC is still used to control conformal coating thickness, viscosity, and conveyor speed.

The Enhanced Inspection Information System (EIIS) is used in many assembly and process areas at CACD to collect, analyze, and report workmanship data. EIIS generates a Workmanship Alert to manufacturing teams when any significant change to the process is detected. The system identifies workmanship problems by the individual in the process and number of the part with the workmanship problem. It also provides timely and detailed Pareto charts and tailored product quality reports. Lastly, EIIS provides workmanship data to allow surveillance inspection in place of 100% inspection.

CACD uses several types of SPC in test. Automatic and constant data logging and analysis are used on Automated Test Equipment where that data is uploaded into a large database. Extraction routines create histograms or frequency plots of common items. Northwest Analytical's Quality Analyst is used for procedure parametrics and Product Assurance Data System and Product Performance System failure analysis. Parametric data is collected for major test problems, analyzed with the Quality Analyst, and taken to engineering for possible design changes. SPC is also used for burn-in process monitoring where only sample data is taken unless charts go out of control. Taking only sample data in place of 100% testing saves time and money. CACD also plans to use SPC on all non-developmental items by establishing a design C_{pk} of 1.33 for internal module specifications.

CACD has had a formal SPC training program since 1986, and 348 employees have completed the 28-hour class to date. Those 348 employees include engineers, managers, facilitators, and assembly, test, and quality production leads. Of those 348 employees, 168 engineers have also completed DOE training. An additional 132 (managers and team leaders) of the 348 employees have completed C_{pk} and six sigma training.

3.3 PRODUCTION

MANUFACTURING PLAN

Inert Atmosphere Wave Soldering Process

The environmental efforts of the Montreal Protocol, the availability of inert gas wave soldering technology, and the desire to reduce process maintenance costs drove CACD to implement an inert atmosphere wave soldering process. The goal of this program was to identify a low-residue flux to replace the currently-used RMA flux and to eventually move to a non-CFC based, environmentally-friendly cleaning system.

The processes were using an RMA flux on an older, non-inert wave soldering system. This older system required disposal of dross waste from the wave, in addition to requiring either solvent-based or saponified water-based cleaning systems. The newer, inert wave soldering system would allow for the use of low-residue flux to significantly reduce the requirements of the cleaning system, if not eliminate it altogether.

One of the key strategies in implementing the inert wave soldering process was converting different products throughout the CACD Coralville plant. This strategy entailed qualification testing, gaining approval to use the process on existing contracts, incorporating it as a standard process on future contracts, and working with MIL-SPEC custodians to change current flux requirements.

Qualification testing was the foundation for the conversion strategy. CACD, in qualification testing, exceeded both the MIL-STD-2000A Appendix A requirements and the testing required by a subsequent Navy memorandum regarding the implementation of new fluxing systems. In addition to in-house testing, CACD was able to leverage qualification data generated by Rockwell's Tactical Systems Division on the Hellfire program. Testing results from both the Tactical Systems Division and internal CACD showed the MIL-STD-2000A, Navy memorandum, and CACD internal requirements were all met.

The next strategy was to gain approval across all contracts in place at CACD. This was accomplished by changing existing specifications and obtaining a deviation on all existing contracts that did not require MIL-STD-2000A. Changes to MIL-SPECs were accomplished in a six-month period. In addition to the local contract deviation, Rockwell was instrumental in driving changes to MIL-STD-454, Requirement 5 to allow low-residue flux chemistries.

As a part of the qualification testing, experiments were conducted to establish optimum processing parameters. These experiments were very successful in pointing out both process parameter and equipment-driven defects. Through these experiments and associated process and equipment changes, CACD was able to reduce its defect rate from 2300 ppm to 700 ppm.

The results from this effort provided a wave soldering process that was more environmentally safe, less costly to maintain, and reduced the overall processing defect rates.

QUALIFY MANUFACTURING PROCESS

High Voltage Power Supply Encapsulation

Rockwell CACD faced a formidable task of developing process and facilities capabilities as the result of receiving a job for the MILSTAR program that involved the production of 24 high voltage power supplies and three spares. The challenges included that the high voltage power supply had been designed by another manufacturer, required building new facilities with a controlled environment, utilized a difficult encapsulating process, and required the transfer of production technology from the other manufacturer. The production schedule was set at just six months.

The first step was to establish a temporary facility for production where experiments in process development could ensue while the permanent facility was being built. The permanent facility was also designed for future production requirements for other products such as multi-chip modules and flat panel displays. Equipment selection was also accomplished for the complete production cycle.

Process development was critical for the success of delivering quality products on schedule. Development included flowcharting, producibility reviews, DOE, fabrication of non-functional prototypes, encapsulation experiments, process documentation, and operator training. The total number of processes developed was greater than 25, a significant accomplishment as Rockwell had little prior experience, the design was developed elsewhere, and there was a short schedule.

DOE were performed because most encapsulating processes for high voltage power supplies involve the use of non-conductive liquid materials where voiding was not a problem. This assembly required the use of silicone as the encapsulating material and careful process development and process control to eliminate the occurrence of voiding. Peel strength was considered critical to achieve the control of voiding. In the DOE, factors such as primer concentration, primer application method, preheat, number of primer applications, and surface contamination levels were analyzed to establish the optimum process. The results allowed Rockwell to concentrate on the factors with the most impact, which were determined to be the primer application method and the number of applications.

The product also presented encapsulating difficulties due to its size. The unit was 16.7 inches by 5.0 inches by 7.6 inches. This resulted in approximately 7.7 pounds of silicone being used to fully encapsulate the assembly, requiring extra precautions to control voiding in the material. The total time required to encapsulate the assembly was approximately one week.

Rockwell CACD was successful in its effort to perform this job. A process was developed to encapsulate the power supply with no voiding, a facility was built to meet produc-

tion requirements for this job as well as others, and the product was delivered to the customer on the required schedule.

Chip-On-Board/Multi-Chip Module

CACD developed chip-on-board (COB) manufacturing processes in an attempt to miniaturize an oscillator module used extensively throughout CACD products. COB processes on the manufacturing floor were new and would require both process and equipment integration activities. CACD undertook a project that would establish those COB manufacturing processes.

An integrated PST conducted extensive experimental designs, and trained operators and engineers on these new processes. The PST included engineers from the microelectronics laboratory, engineers from advanced manufacturing, and individuals from the manufacturing floor. The engineers from the microelectronics laboratory assisted in establishing COB processes, provided material recommendations, and provided initial training for both engineers and operators. Engineers from advanced manufacturing led the team and were responsible for equipment selection and setup, and developing and documenting all required processes. Operators were part of the team to obtain training and to improve the transition of the processes to the manufacturing floor.

DOE were used extensively to develop these new processes. Processes studied included bare die handling, die attach, UV ozone cleaning, wire bonding, encapsulation, seam sealing, and de-lidding. In bare die handling, the goal was to develop a consistent process that would be easy to use and would provide the most protection to the die. In die attach, an adhesion process needed to be developed to minimize ionics, outgassing, cure temperature and voiding, and provide good thermal and electrical conductivity. Silver-filled conductive polymers were used as the primary interconnect medium between the chip and the board. Printed wiring boards with Bismaleimide Triazine resin were used because of their mechanical and thermal properties.

A cleaning process was instituted prior to the wire bonding process to remove organics. A DOE helped ascertain if there was a significant difference between UV ozone or plasma cleaning methods. It was determined that there was little difference, so UV ozone cleaning was selected. Further experiments were conducted to optimize time and distance parameters using wire bond pull strength and Fourier Transform Infrared analysis.

A wire bonding process was also established using DOE techniques. Significant training was accomplished with operators from manufacturing due to the newness of this process. Wire bonding was accomplished with both gold and aluminum die. Parameters such as force,

time, ultrasonics, and temperature were all included in the experiments. Temperature was limited by the Bismaleimide Triazine board and force was driven by the wire diameter, so the majority of the experiments concentrated on time and ultrasonics.

The encapsulation on the bare die had to provide good mechanical protection and be able to withstand thermal cycles of -55 to +125 degrees C. Process parameters studied were chip and wire coverage, and the application process. The primary goal of the application process was to minimize air bubbles.

Seam sealing was accomplished to provide an hermetic environment. Moisture bake-out prior to sealing was found to be a critical process; DOE were performed on this process using residual gas analysis as a response. The actual sealing process used a brazing operation of electroless nickel over a Kovar lid and package. A critical parameter in this process was the bond between the lid and the package. The de-lidding process would mill the lid and seal in such a way that the package would have a resealable finish after this process.

Key conclusions learned from this effort include the criticality of controlling processes and materials. Packages, boards, and die along with adhesives all had to be tightly controlled. DOE turned out to be invaluable in establishing these processes in a short time. Lastly, the teaming arrangement allowed internal resources within CACD that had experience with COB manufacturing processes to be involved early in the design or the processes. This early involvement significantly decreased implementation time.

PIECE PART CONTROL

Kit Tracking

The consolidation of operations within Rockwell prompted the relocation of warehouse and kitting operations to the Coralville, Iowa facility. The previous process experienced significant time delays in filling kit shortages because the warehouse facility was located in Utah, and the technique for tracking shortages was manual. The process was susceptible to personal technique variances and errors because inventory and production schedules relied on physical audits to verify accuracy. The Coralville facility, cognizant of these problems, developed a more automated system to identify part shortages, stage partial kits, match back orders with partial issues, and provide accurate production control. This process was intended to be integrated with other paperless tracking systems that were being developed and utilized at this site.

The new system reduced the number of steps in the process, provided for faster identification of shortages, resulted in a more comprehensive reporting and prioritization method, established more uniformity in the staging process,

and significantly improved the ability to locate issued kits and fill shortages on the production floor.

With the automated kit tracking system, the Coralville facility can more readily fill orders and provide accurate control for the production operation.

COMPUTER-AIDED MANUFACTURING

Electronic Work Instructions

The previous system to produce work instructions at Rockwell CACD was cumbersome and costly. An Industrial Engineering (IE) technician would pull engineering drawings, conduct a brief analysis, and send the drawing to CACD's Manufacturing Data Center. The Center would then generate drawings for each route and send the drawings back to the IE technician. The IE technician then added assembly notes to the drawings, made copies of the drawings, and distributed the copies to the floor. A product was needed to eliminate the bulk of this paperwork, and CACD established the following objectives for a new system:

- improve throughput and reduce effort in the creation and maintenance of work instructions;
- eliminate reproduction, filing, and distribution costs associated with paper write-ups;
- improve control of product configuration and revision implementation; and,
- increase visibility into workmanship details.

CACD now uses an electronic system for work instructions. The new work instructions make use of a Manufacturing Graphics and Integrated Control System for electronics systems and Mechanical Graphic Work Instructions for mechanical systems. Although these systems have been in place since 1987, the fully functional pilot was installed on 20 workstations in 1989. From 1989 to 1995, the number of workstations have gradually been increased to 186.

This system creates drawings in the engineering CAD system. The drawings then go to the Comprehensive Manufacturing File on the mainframe computer, and the graphics files are sent to the Novell Network. Both files are then placed in the production operations' computer system. Next, the drawing files are placed in the Manufacturing Graphics and Integrated Control System on the IE technician's PC for editing. Finally, the drawings and work instructions are sent to the Manufacturing Graphics and Integrated Control System on the operator's PC to be used on the assembly floor.

The need for the Manufacturing Data Center has been eliminated as IE technicians apply manufacturing data to the CAD graphics on-line. The costs associated with the generation, reproduction, and distribution of paper are

eliminated, and there is an average time savings of 20-30 minutes per work instruction. Shop floor errors are more easily found and corrected, and 16 minutes per error are saved. Finally, there is more control over revision levels and configuration changes.

3.4 FACILITIES

FACTORY IMPROVEMENTS

Paperless Work Flow for Electronic Maintenance Work Requests

Rockwell CACD has developed a paperless work flow for electronic Maintenance Work Requests (MWRs). MWRs are used at CACD for tasks such as fixing lighting systems in conference rooms or moving office furniture. There are currently over 3700 MWRs per year at Rockwell, and more than half of these require attachments which are instructions or maps. Ninety to ninety-five percent of the MWRs require minimal documentation, and MWRs are not used for tracking cost, or time spent on the job.

The manual MWR process, requiring a three to four day cycle time, involved completing four-page carbon forms, obtaining authorization, and hand carrying or delivering the request using the internal mail system. Therefore, CACD changed the manual process to a paperless electronic one in response to employee input, to reduce entry errors, promote clarity, reduce delays, and use available tools.

The paperless electronic process for MWRs uses a desk top computer to create and view MWRs, and the authorizing signature for these MWRs has been eliminated. Only front-end edits are allowed, and after the MWR has been sent for processing by the requester, it cannot be edited.

There are many benefits to the electronic MWR. There is less paperwork, as the four-page carbon has been replaced by a single green sheet. There is also reduced paper handling and filing. CACD has eliminated replacing lost MWRs. The electronic MWR is a quicker system, resulting in a more responsive, satisfied customer. The status and history of any electronic MWR can be viewed on-line. The cycle time of an electronic MWR is one day less than that of a manual MWR. Finally, five to ten minutes per request is saved using the electronic MWR.

3.5 MANAGEMENT

PERSONNEL REQUIREMENTS

Human Resources Paperless Workflow System

Rockwell CACD has created a Paperless Workflow System (PWS) to electronically process human resources forms

using a PC and Microsoft Windows. This Division is one of the first in the Rockwell organization to use PWS in a human resources capacity. Key system features include ECN applications, an electronic signature capability, linkage to existing payroll and personnel system, integration with CACD's e-mail system, and security for confidential information.

PWS provides a fully electronic means of form creation, routing, approval, storage, and implementation. When forms are created, they are automatically pre-loaded with the appropriate information. The user retrieves the form on the local PC and fills in the required information after which it can be electronically tracked throughout the routing process.

Rockwell has replaced four manual forms for human resources transactions such as the Employee Change Notice Form, the Personal Status Change Notice, Telephone Extension and Location Record, and the Vacation Control Form. Transactions such as salary increases, lump sum payments, job conversion, department changes, name and marital status changes, address changes, emergency contact changes, phone numbers, and vacation scheduling can be done electronically.

Human resources PWS benefits include paperless processing, real-time changes, elimination of duplicate entry, reduced mainframe and administrative processing costs, and increased customer satisfaction and responsiveness. Rockwell CACD is currently programming the system to eliminate forms in the purchasing and facilities areas. The Paperless Workflow System is scheduled to be integrated into various forms processing activities at Rockwell to fully realize the potential benefits.

Commodity Teams

CACD utilizes cross-functional commodity teams to manage all aspects of key part and material commodities. The teams identify supplier-base management strategies that support the business objectives. Each team tracks industry trends for the technology, identifies current and future product requirements and technology needs, and evaluates current and future supplier base and CACD production capabilities. They evaluate suppliers, identify preferred suppliers, and build relationships to help reduce and improve the supplier base.

Until the 1990s, CACD employed a traditional functional approach to supplier management and purchasing, but was not achieving the required results. The commodity team approach was developed with the goal of improving availability while balancing assets and costs. Although the initial concept was developed in 1990, the only groups involved were the traditional procurement and supplier management functions. The concept was reengineered in 1992 with the company's

HPWS initiative and joint planning which integrated engineering, manufacturing, and marketing with purchasing. In October 1992, a Commodity Steering Team of directors and key managers was established, followed by the formation of a Commodity Council which included commodity team leaders, facilitators, advisors, and the Steering Team. By October of 1994, 16 active, funded teams were in place.

Each Commodity Team is cross functional, has total responsibility for a commodity, and is chartered to establish a business plan for CACD's use of the commodity in support of the company's goals. Current team activities include identification of candidate preferred suppliers, evaluation of current supplier capabilities, projection of future product needs, and development of preliminary strategies for supplier base management. The teams are also working on collocation to break down functional barriers.

The Commodity Teams have been very effective. Since 1992, active part numbers have been reduced by 10%, even though new products and parts have been introduced. Active suppliers have been reduced 42% and shortages reduced by 58%. Material standard costs have also been lowered significantly. Other accomplishments include the development of effective cross-divisional linkages and the establishment of a Supplier Alliance Advisory Council that is helping to establish working partnerships with suppliers and improve communications. Although changing the culture is difficult — requiring persistence and consistency — the company has learned that cross functional cooperation is mandatory to be competitive, and the commodity teams are learning and developing this skill to create a competitive advantage for CACD.

DATA REQUIREMENTS

Electronic Data Interchange

Rockwell CACD began using Electronic Data Interchange (EDI) in its business functions in 1993 with two trading partners and 3700 transactions. The company maintained that EDI would allow it to more quickly and efficiently provide customer support with shorter lead times. Since FY93, CACD has made steady progress in EDI use. FY94 closed with five trading partners and 5600 transactions, and FY95 estimates are for more than 10 trading partners and 10,000 transactions.

CACD executes various transactions in compliance with the ANSI standards. In accounting, CACD utilizes ANSI Standard 820 for Remit Advice, 823 for the Lockbox function and 810 for Invoicing. Today 80-85% of receivables are EDI, which has translated to the elimination of one accounting position. In contracting, CACD uses 840 for Request for Quotes, 843 for Response for Quote and 850 for Purchase Orders. Purchasing utilizes 869 for Order Status

Inquiry, 870 for Order Status Response and eventually 850 for Purchase Order.

Through EDI, CACD can provide same-day response to a Request for Quote. The information needed to reply to the customer is available on the mainframe, and the administrator downloads the data into a spreadsheet, thereby responding as soon as price and schedule data is available.

Using electronic commerce, CACD is providing better customer service, is more responsive to customer needs, and can reduce administrative lead time. Invoicing transactions are created from the Order Management System and are uploaded to the mainframe daily. Also, a decrease in levels of spare parts maintained in inventory and decreased warehousing costs are anticipated in the near future.

Program Planning and Tracking Tool

CACD engineers have developed a computer model of their system engineering processes that imitates the DOD-STD-5000 processes used by Department of Defense system engineers. The IPPD model was developed using Integrated Computer Aided Manufacturing Definition (IDEF-3x) process modeling with a flowcharting tool called ABC Flowcharter. CACD has begun using this model as the engine for many long-needed program management tools.

The use of IDEF-3x process modeling allows CACD engineers to construct a graphical workflow diagram and glossary that describes what the organization does. It depicts time-phased actions that are precedence-linked and performed in a specific scope or scenario. The actions or processes are defined based on engineering project management guidelines developed and documented as best practices. Each phase in the process defined is represented in the model as a separate workflow activity with unique inputs, outputs, controls, and mechanisms. This allows the flexibility to apply the model to any size or type of project CACD users might encounter.

The Systems Engineering and Engineering Information Services Organizations co-developed a Program Planning and Tracking Tool using the IPPD model to both test the model and to put it to work. The goal was to improve program management by loading the corporate memory contained in Engineering Project Manuals into an on-line reference organized by the model into a glossary. Paradox for Windows was used as the glossary tool. Engineers then duplicated the work breakdown in a second commercial off-the-shelf program, Microsoft Project, benchmarking several different-sized CACD projects to be used as examples for future applications. The glossary and project management software were then packaged together with risk reporting/handling and metric scoring programs in an intuitive windows environment usable by both experienced and inexperienced personnel.

The IDEF-3x Process Models will be used as the foundation for process training, cycle time reduction, certification to the ISO-9001 quality standard, bid process improvement through the development of a Standard Work Breakdown Structure, and proliferation of risk and opportunity management templates.

COINS System

Rockwell CACD has begun using COINS, a client/server-based system, to retrieve computer output to PCs in the company. COINS (Figure 3-1) uses magnetic and optical disk media to store character data and provides a substantial indexing and retrieval capability. Information is contained on a RAID device or on 12-inch platters capable of storing 2.6 million pages per platter.

Contained within COINS' indexing capability is a Document Item Index which enables users to apply a sorted field to access line-item information within a large report. This capability differs from the traditional environment where indexing is performed by report date, report ID, and one or two primary keys contained in a column heading. COINS can also extract pages, lines, or blocks of lines from stored reports and apply them to create new documents in a spreadsheet such as management reports or presentations.

This important feature has proven to be an effective tool for the Purchasing, Accounting, Program Planning and Control, and Manufacturing Departments.

Users must have authorization from the application owner to view data. Users are able to do searches on common report keys in a predefined group of reports/applications. COINS also allows automatic indexing of ad-hoc reports; it allows indexing by date, report ID of Accounting Data System, and Product Cost System ad-hoc reports without predefining the data. A user can create a customized report in a predefined application, assign an ID, and retrieve it when required.

As the system conducts a search, it will scan multiple versions of a report or application (group of reports) to locate and retrieve information requested by the user. The user can then download retrieved data to a spreadsheet, word processor, e-mail, or other Windows applications. Therefore, data can be manipulated within a report or application without altering the data in the system.

CACD has realized considerable organizational-wide benefits from this system. There has been a significant reduction in labor costs, storage requirements, and filing costs. At present, COINS supports 750 users in several different places in the organization. In 1992, the average monthly printing requirements of the organization totaled

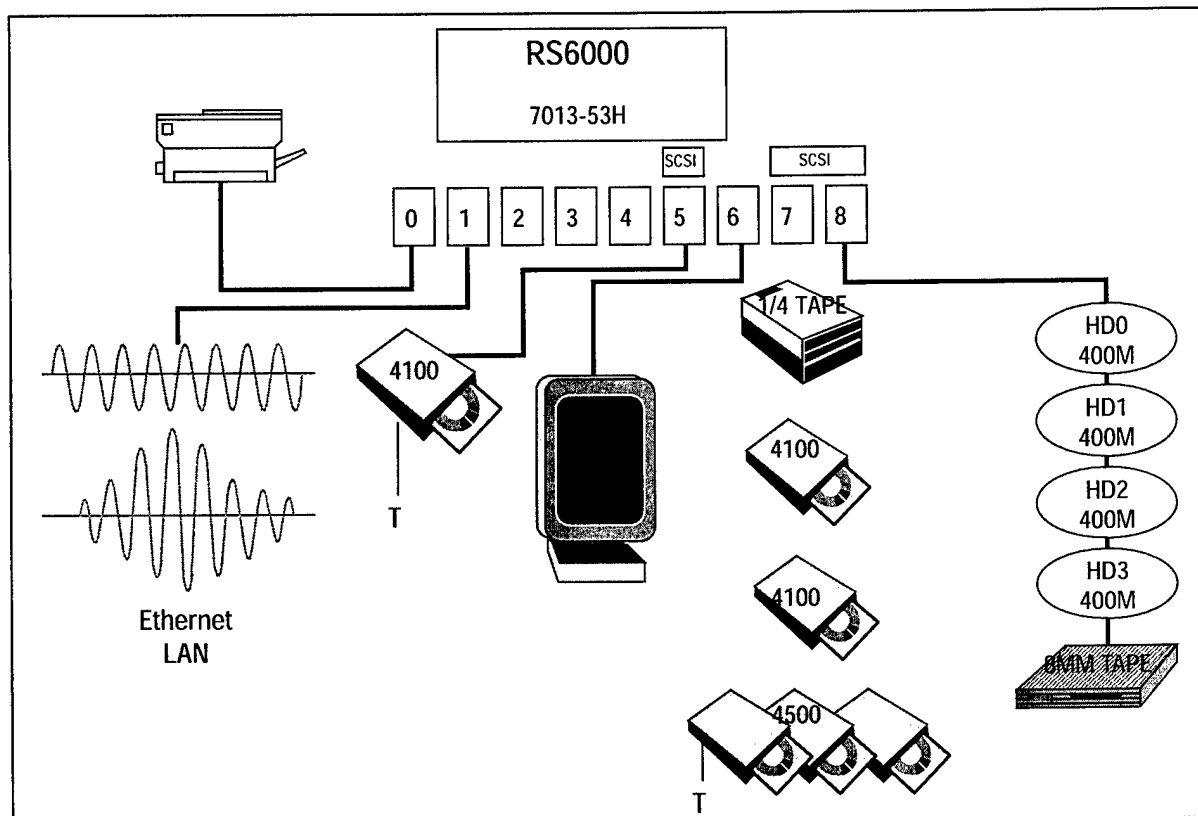

FIGURE 3-1. COINS SYSTEM

four million pages. With the implementation of COINS, the average monthly printing requirements in 1995 have been reduced to two million pages. Similarly in 1992, over 300,000 pages per month were microfilmed and in 1995, CACD is ready to shut down the 3M processor. The expected annual savings amount is \$32K on maintenance, plus film processing and distribution costs.

COINS has also improved business processes for CACD. Reports that provide critical information for management in support of the decision-making process are generated hours ahead of meetings, and the system has eliminated the need for multiple copies of reports since the information can be accessed via the network.

Goals for future COINS efforts at CACD are to:

- continue the migration to COINS as the infrastructure evolves;
- continue the implementation of new versions of software;
- incorporate enhancements that are and will be available;
- convert mainframe data to COINS;
- incorporate the capability of simultaneously downloading data and information retrieval; and,
- upgrade security.

Business Information System

Rockwell CACD's Business Information System (BIS) is a comprehensive financial reporting system that allows quick and easy access to integrated financial data through

a PC-based graphical interface. Information is delivered to the network where it can be accessed, thereby eliminating the need to print management reports.

BIS (Figure 3-2) was conceptualized in August 1991 as a breakout from an existing system, Marketman, an in-house system for marketing and orders information. The goal was to apply the same hierarchical tiering to the sales and profit information and take it one step further, integrating it with the financial parameters. The challenge was to integrate sales information on 1800 contracts and orders, information on 3000 prospects/awards, and make it available to management to support the decision process. The BIS Support Team was comprised of representatives from finance, engineering, information systems, business development, and network support.

BIS implementation was executed in four phases. Phase One, completed in April 1992, consisted of incorporating orders, sales, and gross profit. Phases Two and Three (completed in September 1993), included adding discretionary costs, below-the-line costs, and program net assets employed. Phase Four was completed in September 1994 and consisted of integrating budgets, staffing, capital, and new report formats. Management reporting enhancements were also completed.

Although BIS is a DOS system, it runs in a Windows environment. The system allows the user to "point and shoot" through CACD's hierarchy of programs and products, accessing valuable trend data on past, present, and projected financial performance. It captures information from Marketman, Orders, and other contract-related information from the Financial Management

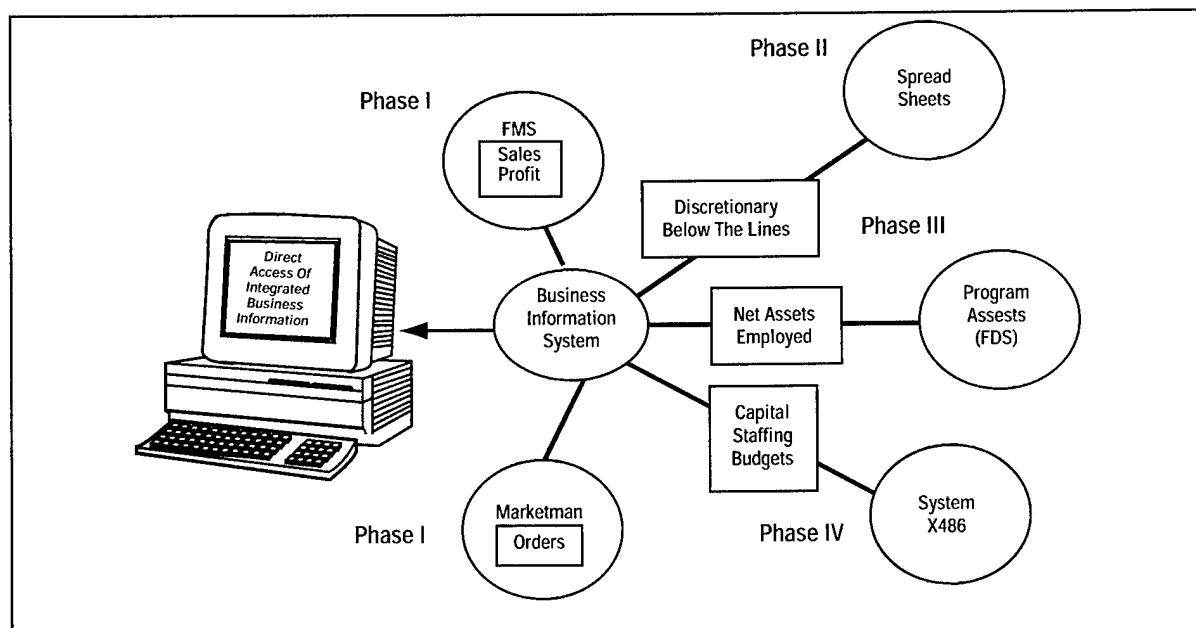

FIGURE 3-2. BUSINESS INFORMATION SYSTEM ARCHITECTURE

System, assets information from the Global Asset Report, and other financial information from spreadsheets generated by administrative support. BIS integrates this information and facilitates access to the history, the current forecast, and the Annual Operating Plan for a variety of financial parameters.

Management information/reports that are available from BIS can also be generated using commercial software such as Excel, PowerPoint, and e-mail. A PowerPoint viewer is available on the network to view reports. This has made information more accessible to more people. The use of e-mail not only allows a user to attach a document and send it over the network to another person, it has also increased communications across the organization.

BIS has met its goal to help the company perform more efficiently by providing reliable and timely information to management. As a result of BIS, information is being shared throughout the Division by organizations such as engineering, manufacturing, finance, and marketing personnel, thereby creating a better understanding of roles and responsibility to the company and sister organizations. The system can be accessed from any location in the company. Savings also include a reduction in the number of financial data management personnel from 17 to seven in the past four years. BIS provides faster, less expensive information which results in greater business opportunities for the company.

QUALITY ASSURANCE

Enhanced Inspection Information System

Rockwell CACD uses the quality tool EIIS to monitor quality and continually strive for improvement. This system manages workmanship databases that include Process Assurance Data Systems, the Test Repair and Configuration Control System, Manufacturing Graphics and Integrated Control, and the Production Inventory Optimization System.

Data is continually processed and analyzed to achieve quality control throughout the manufacturing process. The system automatically notifies the proper quality organizations with workmanship alerts and provides data in usable formats such as Pareto charts, volume charts, bar charts, and various field reports. Reports are provided formally on a weekly basis for assembly operations and equipment, and on a monthly basis for the manufacturing group summaries.

Workmanship alerts are automatically issued to quality engineering personnel who work with the applicable Product Support Team to resolve discrepancies. Workmanship data is statistically analyzed to monitor the process for any changes. Each assembly part number at each operation is monitored to maintain control of quality. Trend analysis is based on the past 25 inspection observations.

The EIIS has become a major quality tool in CACD's pursuit of improvement and automation.

APPENDIX A

TABLE OF ACRONYMS

ACRONYM	DEFINITION
ABC	Activity-Based Costing
AE&CDP	Advanced Engineering and Core Design Process
APOS	Automated Purchase Order System
BIS	Business Information System
BMP	Best Manufacturing Practices
CACD	Collins Avionics and Communication Division
COB	Chip-On-Board
DOE	Design of Experiments
ECN	Enterprise Core Network
EDI	Electronic Data Interchange
EIIS	Enhanced Inspection Information System
EPICS	Enterprise Product Information Control System
HPWS	High Performance Work System
IE	Industrial Engineering
IDEF-3x	Integrated Computer Aided Manufacturing Definition
IPPD	Integrated Product and Process Development
LADS	Labor Authorization and Distribution System
MAESTRO	Material Advanced Enterprise System Rockwell Operations
MWR	Maintenance Work Request
PFR	Pay From Receipt
PST	Product Support Team
PVID	Parametric and Vendor Information Database
PWS	Paperless Workflow System
ROSA™	Reduced Oxide Soldering Activation
SERA	Sequential Electrochemical Reduction Analysis
STEP	Surveillance Through Excellence Program
TRACS	Test, Repair, and Configuration System

APPENDIX B

BMP SURVEY TEAM

TEAM MEMBER	ACTIVITY	FUNCTION
Larry Robertson (812) 854-5336	Crane Division Naval Surface Warfare Center Crane, IN	Team Chairman
Amy Scanlan (301) 403-8100	BMP Center of Excellence College Park, MD	Technical Writer
DESIGN/TEST TEAM		
Ron Cox (812) 854-5251	Crane Division Naval Surface Warfare Center Crane, IN	Team Leader
Steve Ratz (317) 353-7151	Naval Air Warfare Center Aircraft Division - Indianapolis Indianapolis, IN	
PRODUCTION/FACILITIES TEAM		
Nick Keller (812) 854-5331	Crane Division Naval Surface Warfare Center Crane, IN	Team Leader
Mike Frederickson (317) 226-5603	Electronics Manufacturing Productivity Facility Indianapolis, IN	
Sophy Wong (909) 273-4994	Naval Warfare Assessment Division, Corona Corona, CA	
MANAGEMENT/LOGISTICS TEAM		
Rick Purcell (301) 403-8100	BMP Center of Excellence College Park, MD	Team Leader
Larry Halbig (317) 353-3838	Naval Air Warfare Center Aircraft Division - Indianapolis Indianapolis, IN	
Monica Faurote (317) 353-7109	Naval Air Warfare Center Aircraft Division - Indianapolis Indianapolis, IN	

APPENDIX C

PROGRAM MANAGER'S WORKSTATION

The Program Manager's Workstation (PMWS) is a series of expert systems that provides the user with knowledge, insight, and experience on how to manage a program, address technical risk management, and find solutions that industry leaders are using to reduce technical risk and improve quality and productivity. This system is divided into four main components; KNOW-HOW, Technical Risk Identification and Mitigation System (TRIMS), BMP Database, and Best Manufacturing Practices Network (BMPNET).

- **KNOW-HOW** is an intelligent, automated method that turns "Handbooks" into expert systems, or digitized text. It provides rapid access to information in existing handbooks including Acquisition Streamlining, Non-Development Items, Value Engineering, NAVSO P-6071 (Best Practices Manual), MIL-STD-2167/2768, SecNav 5000.2A and the DoD 5000 series documents.
- **TRIMS** is based on DoD 4245.7-M (the transition templates), NAVSO P-6071 and DoD 5000 event oriented acquisition. It identifies and ranks the high risk areas in a program. TRIMS conducts a full range of risk assessments throughout the acquisition process so corrective action can be initiated before risks develop into problems. It also tracks key project documentation from concept through production including goals, responsible personnel, and next action dates for future activities in the development and acquisition process.
- The **BMP Database** draws information from industry, government, and the academic communities to include documented and proven best practices in design, test, production, facilities, management, and logistics.

Each practice in the database has been observed and verified by a team of experienced government engineers. All information gathered from BMP surveys is included in the BMP Database, including this survey report.

- **BMPNET** provides communication between all PMWS users. Features include downloading of all programs, E-mail, file transfer, help "lines", Special Interest Groups (SIGs), electronic conference rooms and much more. Through BMPNET, IBM or compatible PC's and Macintosh computers can run all PMWS programs.

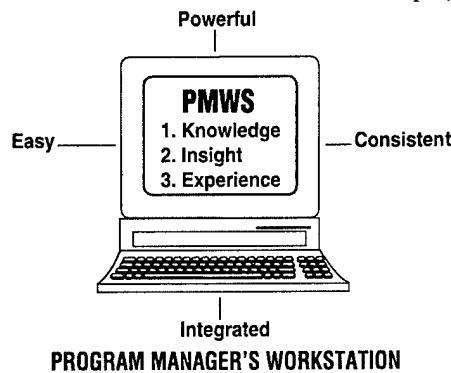

- To access **BMPNET** efficiently, users need a special modem program. This program can be obtained by calling the BMPNET using a VT-100/200 terminal emulator set to 8,N,1. Dial (703) 538-7697 for 2400 baud modems and (703) 538-7267 for 9600 baud and 14.4 kb. When asked for a

user profile, type: DOWNPC or DOWNMAC <return> as appropriate. This will automatically start the Download of our special modem program. You can then call back using this program and access all BMPNET functions. The General User account is:

USER PROFILE: BMPNET
USER I.D.: BMP
Password: BMPNET

If you desire your own personal account (so that you may receive E-Mail), just E-Mail a request to either Ernie Renner (BMP Director) or Brian Willoughby (CSC Program Manager). If you encounter problems please call (703) 538-7799.

APPENDIX D

NAVY CENTERS OF EXCELLENCE

Automated Manufacturing Research Facility (301) 975-3414

The Automated Manufacturing Research Facility (AMRF) – a National Center of Excellence – is a research test bed at the National Institute of Standards and Technology located in Gaithersburg, Maryland. The AMRF produces technical results and transfers them to the Navy and industry to solve problems of automated manufacturing. The AMRF supports the technical work required for developing industry standards for automated manufacturing. It is a common ground where industry, academia, and government work together to address pressing national needs for increased quality, greater flexibility, reduced costs, and shorter manufacturing cycle times. These needs drive the adoption of new computer-integrated manufacturing technology in both civilian and defense sectors. The AMRF is meeting the challenge of integrating these technologies into practical, working manufacturing systems.

Electronics Manufacturing Productivity Facility (317) 226-5607

Located in Indianapolis, Indiana, the Electronics Manufacturing Productivity Facility (EMPF) is a National Center of Excellence established to advance state-of-the-art electronics and to increase productivity in electronics manufacturing. The EMPF works with industry, academia, and government to identify, develop, transfer, and implement innovative electronics manufacturing technologies, processes, and practices. The EMPF conducts applied research, development, and proof-of-concept electronics manufacturing and design technologies, processes, and practices. It also seeks to improve education and training curricula, instruction, and necessary delivery methods. In addition, the EMPF is striving to identify, implement, and promote new electronics manufacturing technologies, processes, materials, and practices that will eliminate or reduce damage to the environment.

National Center for Excellence in Metalworking Technology (814) 269-2420

The National Center for Excellence in Metalworking Technology (NCEMT) is located in Johnstown, Pennsylvania and is operated by Concurrent Technologies Corporation (CTC), a subsidiary of the University of Pittsburgh Trust. In support of the NCEMT mission, CTC's primary focus includes working with government and industry to develop improved manufacturing technologies including advanced methods, materials, and processes, and transfer-

ring those technologies into industrial applications. CTC maintains capabilities in discrete part design, computerized process analysis and modeling, environmentally compliant manufacturing processes, and the application of advanced information science technologies to product and process integration.

Center of Excellence for Composites Manufacturing Technology (414) 947-8900

The Center of Excellence for Composites Manufacturing Technology (CECMT), a national resource, is located in Kenosha, Wisconsin. Established as a cooperative effort between government and industry to develop and disseminate this technology, CECMT ensures that robust processes and products using new composites are available to manufacturers. CECMT is operated by the Great Lakes Composites Consortium. It represents a collaborative approach to provide effective advanced composites technology that can be introduced into industrial processes in a timely manner. Fostering manufacturing capabilities for composites manufacturing will enable the U.S. to achieve worldwide prominence in this critical technology.

Navy Joining Center (614) 486-9423

The Navy Joining Center (NJC) is a Center of Excellence established to provide a national resource for the development of materials joining expertise, deployment of emerging manufacturing technologies, and dissemination of information to Navy contractors, subcontractors, Navy activities, and U.S. industry.

The NJC is located in Columbus, Ohio, and is operated by Edison Welding Institute (EWI), the nation's largest industrial consortium dedicated to materials joining. The NJC combines these resources with an assortment of facilities and demonstrated capabilities from a team of industrial and academic partners. NJC technical activities are divided into three categories - Technology Development, Technology Deployment, and Technology Transfer. Technology Development maintains a goal to complete development quickly to initiate deployment activities in a timely manner. Technology Deployment includes projects for rapid deployment teaming and commercialization of specific technologies. The Technology Transfer department works to disseminate pertinent information on past and current joining technologies both at and above the shop floor.

APPENDIX E

NEW BEST MANUFACTURING PRACTICES PROGRAM TEMPLATES

Since 1985, the BMP Program has applied the templates philosophy with well-documented benefits. Aside from the value of the templates, the templates methodology has proven successful in presenting and organizing technical information. Therefore, the BMP program is continuing this existing “knowledge” base by developing 17 new templates that complement the existing DoD 4245.7-M or Transition from Design to Production templates.

The development of these new templates was based in part on Defense Science Board studies that have identified new technologies and processes that have proven successful in the last few years. Increased benefits could be realized if these activities were made subsets of the existing, compatible templates.

Also, the BMP Survey teams have become experienced in classifying Best Practices and in technology transfer.

The Survey team members, experts in each of their individual fields, determined that data collected, while related to one or more template areas, was not entirely applicable. Therefore, if additional categories were available for Best Practices “mapping,” technology transfer would be enhanced.

Finally, users of the Technical Risk Identification and Mitigation System (TRIMS) found that the program performed extremely well in tracking most key program documentation. However, additional categories – or templates – would allow the system to track all key documentation.

Based on the above identified areas, a core group of activities was identified and added to the “templates baseline.” In addition, TRIMS was modified to allow individual users to add an unlimited number of user-specific categories, templates, and knowledge-based questions.

APPENDIX F

COMPLETED SURVEYS

BMP surveys have been conducted at the companies listed below. Copies of older survey reports may be obtained through DTIC or by accessing the BMPNET. Requests for copies of recent survey reports or inquiries regarding the BMPNET may be directed to:

Best Manufacturing Practices Program
4321 Hartwick Rd.
Suite 308
College Park, MD 20740
Attn: Mr. Ernie Renner, Director
Telephone: 1-800-789-4267
FAX: (301) 403-8180
ernie@bmpcoe.org

COMPANIES SURVEYED

Litton
Guidance & Control Systems Division
Woodland Hills, CA
October 1985 and February 1991

Texas Instruments
Defense Systems & Electronics Group
Lewisville, TX
May 1986 and November 1991

Harris Corporation
Government Support Systems Division
Syosset, NY
September 1986

Control Data Corporation
Government Systems Division
(Computing Devices International)
Minneapolis, MN
December 1986 and October 1992

ITT
Avionics Division
Clifton, NJ
September 1987

UNISYS
Computer Systems Division
(Paramax)
St. Paul, MN
November 1987

Honeywell, Incorporated
Undersea Systems Division
(Alliant Tech Systems, Inc.)
Hopkins, MN
January 1986

General Dynamics
Pomona Division
Pomona, CA
August 1986

IBM Corporation
Federal Systems Division
Owego, NY
October 1986

Hughes Aircraft Company
Radar Systems Group
Los Angeles, CA
January 1987

Rockwell International Corporation
Collins Defense Communications
Cedar Rapids, IA
October 1987

Motorola
Government Electronics Group
Scottsdale, AZ
March 1988

General Dynamics
Fort Worth Division
Fort Worth, TX
May 1988

Hughes Aircraft Company
Missile Systems Group
Tucson, AZ
August 1988

Litton
Data Systems Division
Van Nuys, CA
October 1988

McDonnell-Douglas Corporation
McDonnell Aircraft Company
St. Louis, MO
January 1989

Litton
Applied Technology Division
San Jose, CA
April 1989

Standard Industries
LaMirada, CA
June 1989

Teledyne Industries Incorporated
Electronics Division
Newbury Park, CA
July 1989

Lockheed Corporation
Missile Systems Division
Sunnyvale, CA
August 1989

General Electric
Naval & Drive Turbine Systems
Fitchburg, MA
October 1989

TRICOR Systems, Incorporated
Elgin, IL
November 1989

TRW
Military Electronics and Avionics Division
San Diego, CA
March 1990

Texas Instruments
Defense Systems & Electronics Group
Dallas, TX
June 1988

Bell Helicopter
Textron, Inc.
Fort Worth, TX
October 1988

GTE
C³ Systems Sector
Needham Heights, MA
November 1988

Northrop Corporation
Aircraft Division
Hawthorne, CA
March 1989

Litton
Amecom Division
College Park, MD
June 1989

Engineered Circuit Research, Incorporated
Milpitas, CA
July 1989

Lockheed Aeronautical Systems Company
Marietta, GA
August 1989

Westinghouse
Electronic Systems Group
Baltimore, MD
September 1989

Rockwell International Corporation
Autonetics Electronics Systems
Anaheim, CA
November 1989

Hughes Aircraft Company
Ground Systems Group
Fullerton, CA
January 1990

MechTronics of Arizona, Inc.
Phoenix, AZ
April 1990

Boeing Aerospace & Electronics
Corinth, TX
May 1990

Textron Lycoming
Stratford, CT
November 1990

Naval Avionics Center
Indianapolis, IN
June 1991

Kurt Manufacturing Co.
Minneapolis, MN
July 1991

Raytheon Missile Systems Division
Andover, MA
August 1991

Tandem Computers
Cupertino, CA
January 1992

Conax Florida Corporation
St. Petersburg, FL
May 1992

Hewlett-Packard
Palo Alto Fabrication Center
Palo Alto, CA
June 1992

Digital Equipment Company
Enclosures Business
Westfield, MA and
Maynard, MA
August 1992

NASA Marshall Space Flight Center
Huntsville, AL
January 1993

Department of Energy-
Oak Ridge Facilities
Operated by Martin Marietta Energy Systems, Inc.
Oak Ridge, TN
March 1993

Technology Matrix Consortium
Traverse City, MI
August 1990

Norden Systems, Inc.
Norwalk, CT
May 1991

United Electric Controls
Watertown, MA
June 1991

MagneTek Defense Systems
Anaheim, CA
August 1991

AT&T Federal Systems Advanced
Technologies and AT&T Bell Laboratories
Greensboro, NC and Whippany, NJ
September 1991

Charleston Naval Shipyard
Charleston, SC
April 1992

Texas Instruments
Semiconductor Group
Military Products
Midland, TX
June 1992

Watervliet U.S. Army Arsenal
Watervliet, NY
July 1992

Naval Aviation Depot
Naval Air Station
Pensacola, FL
November 1992

Naval Aviation Depot
Naval Air Station
Jacksonville, FL
March 1993

McDonnell Douglas Aerospace
Huntington Beach, CA
April 1993

Crane Division
Naval Surface Warfare Center
Crane, IN and Louisville, KY
May 1993

Philadelphia Naval Shipyard
Philadelphia, PA
June 1993

R. J. Reynolds Tobacco Company
Winston-Salem, NC
July 1993

Crystal Gateway Marriott Hotel
Arlington, VA
August 1993

Hamilton Standard
Electronic Manufacturing Facility
Farmington, CT
October 1993

Alpha Industries, Inc
Methuen, MA
November 1993

Harris Semiconductor
Melbourne, FL
January 1994

United Defense, L.P.
Ground Systems Division
San Jose, CA
March 1994

Naval Undersea Warfare Center
Division Keyport
Keyport, WA
May 1994

Mason & Hanger
Silas Mason Co., Inc.
Middletown, IA
July 1994

Kaiser Electronics
San Jose, CA
July 1994

U.S. Army
Combat Systems Test Activity
Aberdeen, MD
August 1994

Stafford County Public Schools
Stafford County, VA
August 1994

Sandia National Laboratories
Albuquerque, NM
January 1995

Rockwell Defense Electronics
Collins Avionics and
Communication Division
Cedar Rapids, IA
April 1995

INTERNET DOCUMENT INFORMATION FORM

**A. Report Title: Best Manufacturing Practices: Report of Survey
Conducted at Rockwell Defense Electronics Collins and Communication
Division, Cedar Rapids, IA**

B. DATE Report Downloaded From the Internet: 12/20/01

**C. Report's Point of Contact: (Name, Organization, Address, Office
Symbol, & Ph #): Best Manufacturing Practices
Center of Excellence
College Park, MD**

D. Currently Applicable Classification Level: Unclassified

E. Distribution Statement A: Approved for Public Release

**F. The foregoing information was compiled and provided by:
DTIC-OCA, Initials: __VM__ Preparation Date 12/20/01**

The foregoing information should exactly correspond to the Title, Report Number, and the Date on the accompanying report document. If there are mismatches, or other questions, contact the above OCA Representative for resolution.