

## INTERNET DOCUMENT INFORMATION FORM

**A . Report Title: Best Manufacturing Practices: Report of Survey  
Conducted at McDonnell Douglas Aerospace, Huntington Beach, California**

**B. DATE Report Downloaded From the Internet: 12/19/01**

**C. Report's Point of Contact: (Name, Organization, Address, Office  
Symbol, & Ph #): Best Manufacturing Practices  
Center of Excellence  
College Park, MD**

**D. Currently Applicable Classification Level: Unclassified**

**E. Distribution Statement A: Approved for Public Release**

**F. The foregoing information was compiled and provided by:  
DTIC-OCA, Initials: \_\_VM\_\_ Preparation Date 12/19/01**

The foregoing information should exactly correspond to the Title, Report Number, and the Date on the accompanying report document. If there are mismatches, or other questions, contact the above OCA Representative for resolution.



*Report of Survey Conducted at*

**MCDONNELL DOUGLAS AEROSPACE**

HUNTINGTON BEACH, CALIFORNIA

*APRIL 1993*

## ***BEST MANUFACTURING PRACTICES***



*Center of*

*Best Manufacturing Practices*

*Excellence for*

**20011220 065**

*AGI 02-03-0560*

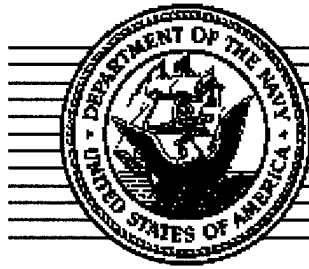

# BMP

## “CRITICAL PATH TEMPLATES FOR TRANSITION FROM DEVELOPMENT TO PRODUCTION”

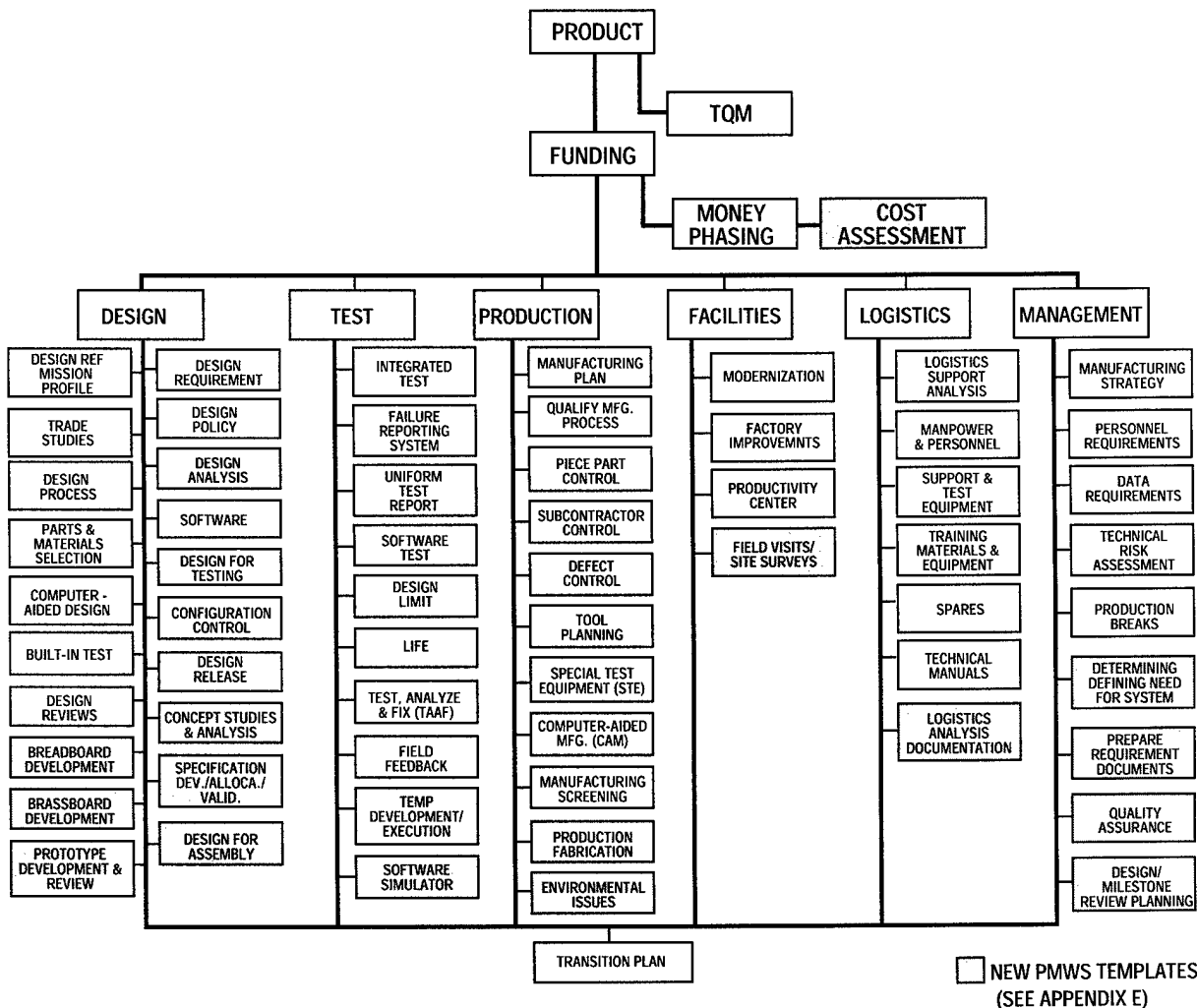

# CONTENTS

---

## 1. EXECUTIVE SUMMARY

1.1	BACKGROUND.....	1
1.2	BEST PRACTICES.....	1
1.3	INFORMATION.....	3
1.4	PROBLEM AREAS.....	4

---

## 2. INTRODUCTION

2.1	SCOPE.....	5
2.2	SURVEY PROCESS.....	5
2.3	COMPANY OVERVIEW.....	5
2.4	ACKNOWLEDGEMENTS.....	5
2.5	COMPANY POINT OF CONTACT.....	6

---

## 3. BEST PRACTICES

### 3.1 DESIGN

#### DESIGN REQUIREMENTS

Electronic Development Fixture.....	7
-------------------------------------	---

#### DESIGN POLICY

CAD/CAM/CAE Unigraphics II.....	8
---------------------------------	---

#### DESIGN PROCESS

Integrated Product Development.....	9
-------------------------------------	---

#### DESIGN ANALYSIS

Underwater Test Facility.....	10
-------------------------------	----

#### CONFIGURATION CONTROL

Electronic Change Control.....	11
--------------------------------	----

#### CONCEPT STUDIES AND ANALYSIS

Strategic Technology Management.....	12
--------------------------------------	----

#### PROTOTYPE DEVELOPMENT AND REVIEW

Rapid Prototyping of Small Parts.....	12
---------------------------------------	----

Rapid Prototyping Simulation and Software.....	12
--	----

### 3.2 TEST

#### DESIGN LIMIT

NDT Analyses/Equipment.....	13
-----------------------------	----

Automated Load Programming System.....	14
--	----

# CONTENTS (Continued)

---

<b>3.2</b>	<b>TEST (CONTINUED)</b>	
	<b>TEST, ANALYZE, AND FIX</b>	
	Dynamics Laboratory .....	14
<b>3.3</b>	<b>PRODUCTION</b>	
	<b>MANUFACTURING PLAN</b>	
	Rapid Prototyping for Single Stage Rocket Technology .....	15
	<b>SUBCONTRACTOR CONTROL</b>	
	California Supplier Improvement Program .....	16
	<b>COMPUTER-AIDED MANUFACTURING (CAM)</b>	
	Numerical Control Simulation/Verification .....	16
	Graphic Interactive Programming .....	17
	<b>PRODUCTION FABRICATION</b>	
	Aluminum Welding Practices .....	18
<b>3.4</b>	<b>FACILITIES</b>	
	<b>MODERNIZATION</b>	
	Separation Rail and Attenuator Tube Center .....	18
	Factory Rearrangement .....	18
	<b>FACTORY IMPROVEMENTS</b>	
	Facilities Benchmarking .....	19
	Advanced Composite Technology .....	19
	Energy Efficient Cleanroom-Design Development .....	19
	Factory Improvement Team .....	20
	Optical Disk Data Records .....	20
<b>3.5</b>	<b>LOGISTICS</b>	
	<b>MANPOWER AND PERSONNEL</b>	
	Technology Management-Resource Assessment and Planning .....	20
<b>3.6</b>	<b>MANAGEMENT</b>	
	<b>MANUFACTURING STRATEGY</b>	
	Horizontal Teams .....	21
	Process Based Management .....	22
	Survey of Organization .....	22
	MDA-West/DPRO Customer Relations .....	23
	Civic and Community Affairs .....	23
	<b>DATA REQUIREMENTS</b>	
	MDA-West/Customer Complaint Tracking System .....	24

# CONTENTS (Continued)

---

## 4. INFORMATION

### 4.1 DESIGN

#### DESIGN POLICY

System Architecture .....25

### 4.2 TEST

#### INTEGRATED TEST

Concurrent Design and Test .....25

#### LIFE

Solution Process Control and Salt Spray Testing .....26

### 4.3 PRODUCTION

#### QUALIFY MANUFACTURING PROCESS

Development of Fiber Optic Manufacturing Capabilities .....26

#### PIECE PART CONTROL

SPC Applications in Assembly Hole Drilling .....26

#### TOOL PLANNING

Tool Management System .....27

Tool Tracking .....27

#### COMPUTER-AIDED MANUFACTURING

Tube Center .....27

#### ENVIRONMENTAL ISSUES

Environmental Improvement Program .....28

### 4.4 FACILITIES

#### FACTORY IMPROVEMENTS

Operations Business Management System Integrated Production

Engineering Management Systems .....28

### 4.5 LOGISTICS

#### SPARES

Sale of Spares .....29

### 4.6 MANAGEMENT

#### MANUFACTURING STRATEGY

Strategic Quality Planning .....29

Strategic Business Objectives .....30

# CONTENTS (Continued)

---

<b>4.6</b>	<b>MANAGEMENT</b>	
	<b>DATA REQUIREMENTS</b>	
	CALS .....	31
	MDA-West/Non-conformance Database .....	32
	<b>QUALITY ASSURANCE</b>	
	Quality Assessment.....	33
	Enterprise Quality Council .....	33

---

<b>5.</b>	<b>PROBLEM AREAS</b>	
<b>5.1</b>	<b>FUNDING</b>	
	<b>MONEY PHASING</b>	
	Lack of Adequate Research, Development, Test and Evaluation Funding for Concurrent Engineering .....	35
<b>5.2</b>	<b>PRODUCTION</b>	
	<b>ENVIRONMENTAL ISSUES</b>	
	Composite Disposal .....	35

---

<b>APPENDIX A -</b>	<b>TABLE OF ACRONYMS</b> .....	<b>A-1</b>
<b>APPENDIX B -</b>	<b>BMP SURVEY TEAM</b> .....	<b>B-1</b>
<b>APPENDIX C -</b>	<b>NAVY CENTERS OF EXCELLENCE</b> .....	<b>C-1</b>
<b>APPENDIX D -</b>	<b>PROGRAM MANAGER'S WORKSTATION</b> .....	<b>D-1</b>
<b>APPENDIX E -</b>	<b>NEW BEST MANUFACTURING PRACTICES</b>	
	<b>PROGRAM TEMPLATES</b> .....	<b>E-1</b>
<b>APPENDIX F -</b>	<b>PREVIOUSLY COMPLETED SURVEYS</b> .....	<b>F-1</b>

---

# FIGURES

---

## LIST OF FIGURES

3-1	Electronic Development Fixture .....	7
3-2	Detail Design Schedule - What Existed Before and Present .....	8
3-3	CE/IPD Deployment .....	9
3-4	Underwater Test Facility .....	10
3-5	ECC Process .....	11
3-6	NDT Equipment.....	13
3-7	Automated Load Programming System .....	14
3-8	DC-X Vehicle.....	15
3-9	VPPA Welding and Inspection .....	17
3-10	Horizontal Teams Structure .....	21
3-11	Seven-Step Process Based Management Approach .....	22
4-1	Enterprise Quality Planning Process .....	30
4-2	Strategic Business Objective Flowdown .....	31
4-3	Non-conformance Database .....	32

---

# SECTION 1

## EXECUTIVE SUMMARY

---

### 1.1 BACKGROUND

The Navy's Best Manufacturing Practices (BMP) program team conducted a survey at the McDonnell Douglas Aerospace (MDA) facilities located in Huntington Beach, California the week of 26-30 April 1993. The purpose of the MDA (also referred to as MDA-West) survey was to review and document its best practices and investigate any potential industry-wide problems. The BMP program will use this documentation as an initial step in a voluntary technology sharing process among the industry and government.

### 1.2 BEST PRACTICES

The best practices documented at MDA are detailed in this report. These topics include:

Item	Page
<b>Electronic Development Fixture</b>	7
MDA uses an electronic development fixture to help functional teams develop Space Station Freedom for NASA.	
<b>CAD/CAM/CAE Unigraphics II</b>	8
MDA has successfully evolved from a two-dimensional drawing facility to using the Unigraphics II to complete three-dimensional solid models.	
<b>Integrated Product Development</b>	9
Integrated Product Development multi-functional teams provide the communications interaction foundation for MDA concurrent engineering efforts.	
<b>Underwater Test Facility</b>	10
MDA constructed an Underwater Test Facility to provide zero gravity test conditions.	
<b>Electronic Change Control</b>	11
Electronic Change Control is part of the enabling technology support system for concurrent engineering and integrated product development efforts at MDA.	

Item	Page
<b>Strategic Technology Management</b>	12
MDA's Advanced Technology Program maintains a goal to develop a method to successfully compete in future technology and advanced programs while minimizing the advanced technology development costs.	
<b>Rapid Prototyping of Small Parts</b>	12
MDA technical specialists have investigated two rapid prototyping technologies to produce small, complex-shaped parts.	
<b>Rapid Prototyping Simulation and Software</b>	12
MDA uses a system to build and test stages concurrently to shorten design time. The software code is automatically generated and documented from models to provide traceability between requirements and design.	
<b>NDT Analyses/Equipment</b>	13
MDA uses NDT evaluation methods to examine manufactured assemblies for defects in material or workmanship.	
<b>Automated Load Programming System</b>	14
Mathematical part models automatically generated by design engineers using CAD models are used for structural testing of fabricated parts.	
<b>Dynamics Laboratory</b>	14
Design engineers are sharing motion and stress analysis information with test engineers at MDA's Dynamics Laboratory.	
<b>Rapid Prototyping for Single Stage Rocket Technology</b>	15
The Single Stage Rocket Technology Program has successfully implemented concurrent engineering and rapid prototyping to build the Delta Clipper experimental vehicle.	

Item	Page	Item	Page
<b>California Supplier Improvement Program</b>	16	<b>Energy Efficient Cleanroom - Design Development</b>	19
MDA joined the California Supplier Improvement Program, a program designed to develop suppliers dedicated to continuous improvement.		MDA applied TQM principles to the process of constructing an Energy Efficient Cleanroom to ensure all of the several customers' requirements would be met.	
<b>Numerical Control Simulation/Verification</b>	16	<b>Factory Improvement Team</b>	20
MDA uses software packages designed for NC program verification to reduce the proofing cycle while improving first time quality and reducing costs.		MDA addressed capital equipment improvement and procurement by creating a team to evaluate possibilities and provide recommendations.	
<b>Graphic Interactive Programming</b>	17	<b>Optical Disk Data Records</b>	20
Graphic Interactive Programming is a project to improve quality, reduce lead times and hard tooling dependency, and to apply standardization to the manufacturing process of various selected extruded parts.		To alleviate control and maintenance of paper documentation for in-house programs, MDA obtained an optical disk storage capability.	
<b>Aluminum Welding Practices</b>	18	<b>Technology Management - Resource Assessment and Planning</b>	20
MDA has invested in a state-of-the art variable polarity plasma arc welding and inspection facility.		MDA established Horizontal Teams and other management techniques to address common issues relating to resource assessment and planning.	
<b>Separation Rail and Attenuator Tube Center</b>	18	<b>Horizontal Teams</b>	21
MDA has developed and installed a self-sustaining manufacturing cell for fabricating the hardware used in a rocket fairing separation system.		MDA restructured the company to a vertical, projectized structure and overlaid Horizontal Teams to ensure integrity of processes and management systems.	
<b>Factory Rearrangement</b>	18	<b>Process Based Management</b>	22
MDA has established a factory rearrangement team to provide internal customers with a systematic process for obtaining factory space.		MDA directs overall manufacturing management through a seven-step process-based approach.	
<b>Facilities Benchmarking</b>	19	<b>Survey of Organization</b>	22
MDA conducted a competitive comparison between its facilities, other McDonnell Douglas operations, and outside companies to identify key performance measures in facilities functions and provide guidelines for improvement.		MDA uses a Survey of Organization to determine the overall working atmosphere and assess the company's performance capabilities.	
<b>Advanced Composite Technology</b>	19	<b>MDA-West/DPRO Customer Relations</b>	23
To ensure composite manufacturing would become a viable assembly process, MDA developed a new philosophy to include minimum engineering formality, low cost production methods, concurrent design and manufacturing, and fixed price bids.		A stronger relationship with DPRO was initiated to identify and resolve concerns as part of the MDA rededication to quality.	
		<b>Civic and Community Affairs</b>	23
		MDA maintains a strong civic commitment through its employee volunteers and primary funding resources.	

Item	Page
<b>MDA-West/Customer Complaint Tracking System</b>	<b>24</b>
A computer program was developed to track corrective action requests for DPRO and MDA personnel.	

### **1.3 INFORMATION**

The following information items were documented at MDA. These topics include:

Item	Page
<b>System Architecture</b>	<b>25</b>
MDA realized substantial benefits as a result of changing to concurrency of data across the many minicomputers and mainframe computers.	
<b>Concurrent Design and Test</b>	<b>25</b>
MDA has converged test development with concurrent engineering efforts.	
<b>Solution Process Control and Salt Spray Testing</b>	<b>26</b>
An existing test chamber could not support salt spray testing: MDA contracted with the Engelhardt company to construct a more effective salt spray testing chamber.	
<b>Development of Fiber Optic Manufacturing Capabilities</b>	<b>26</b>
MDA has developed methods of manufacturing and characterizing space qualified fiber optic bundles.	
<b>SPC Applications in Assembly Hole Drilling</b>	<b>26</b>
To determine where the problem of rework in riveted assemblies in the commercial and Titan IV missile applications was occurring, MDA instituted an SPC procedure.	
<b>Tool Management System</b>	<b>27</b>
MDA overcame presetting tooling problems by using an innovative tool management program.	
<b>Tool Tracking</b>	<b>27</b>
MDA maintains careful and precise tracking of thousands of specialized tools.	

Item	Page
<b>Tube Center</b>	<b>27</b>
An automated tube preparation center has been developed using state-of-the-art technology.	
<b>Environmental Improvement Program</b>	<b>28</b>
MDA has identified a process to define and manage environmental risks and developed a policy for environmental guidance.	
<b>Operations Business Management System Integrated Production Engineering Management Systems</b>	<b>28</b>
MDA is installing a singular, computer-based system to replace 12 independent systems that support many business and manufacturing functions. It is also installing an automated system to generate production engineering documentation.	
<b>Sale of Spares</b>	<b>29</b>
MDA has instituted a fair and equitable policy of spares sales to the government.	
<b>Strategic Quality Planning</b>	<b>29</b>
The MDA Strategic Quality Plan is patterned after the Baldrige Award criteria and supports the company objective to become the preferred supplier in its key market segments.	
<b>Strategic Business Objectives</b>	<b>30</b>
MDA uses its vision statement as the basis for its strategic plan which administers the efforts to align the goals and roles of all levels of the company.	
<b>CALS</b>	<b>31</b>
MDA is developing a comprehensive understanding of CALS applications and aligning its resources to accommodate this tool.	
<b>MDA-West/Non-conformance Database</b>	<b>32</b>
MDA created a database to log MRB non-conformances.	
<b>Quality Assessment</b>	<b>33</b>
MDA quality assessment goes beyond the quality audit to help the organization address problems determined during the audit.	

---

Item	Page	Item	Page
<b>Enterprise Quality Council</b>	33	<b>Lack of Adequate Research, Development, Test and Evaluation Funding for Concurrent Engineering</b>	35
A Company Quality Council was established in 1991 to focus attention at MDA on quality and the quality planning process. This council was followed by a streamlined council called the Enterprise Quality Council that is establishing and administering quality policy and values.		The current funding allocations for various phases of life cycle acquisition do not adequately support the product concept and development stages in a concurrent engineering environment.	
<b>1.4 PROBLEM AREAS</b>		<b>Composite Disposal</b>	35
The following industry-wide problem areas were identified by MDA. These topics include:		There is no known method of re-using or recycling graphite-epoxy pre-preg composite materials.	

---

# SECTION 2

## INTRODUCTION

---

### 2.1 SCOPE

The purpose of the Best Manufacturing Practices (BMP) survey conducted at the McDonnell Douglas Aerospace (MDA) facilities was to identify best practices, review manufacturing problems, and document the results. The intent is to extend the use of progressive management techniques as well as high technology equipment and processes throughout industry and government facilities. The ultimate goal of the BMP program is to strengthen the U.S. industrial base and reduce the cost of defense systems by solving manufacturing problems and improving quality and reliability.

A team of engineers accepted an invitation from MDA to review the processes and techniques used in its facilities (MDA-West) located in Huntington Beach, CA. Potential industry-wide problems were also reviewed and documented. The review was conducted at MDA on 26-30 April 1993 by the team identified in Appendix B of this report.

The results of BMP surveys are entered into a database for dissemination through a central computer network. The actual exchange of detailed data will be between companies at their discretion.

The results of this survey should not be used to rate MDA with other government activities, defense contractors, or commercial companies. The survey results have no bearing on one facility's performance over another's. *The documentation in BMP reports is not intended to be all inclusive of the activity's best practices. Only selected non-proprietary practices are reviewed and documented by the BMP survey team.*

### 2.2 SURVEY PROCESS

This survey was performed under the general survey guidelines established by the Department of the Navy. The survey concentrated on the functional areas of design, test, production, facilities, logistics, and management. The team evaluated MDA's policies, practices, and strategies in these areas.

Furthermore, individual practices reviewed were categorized as they relate to the critical path templates of DoD 4245.7-M, "Transition from Development to Production." MDA identified potential best practices and industry-wide problems. These practices and other areas of interest were discussed, reviewed, and documented for distribution

throughout the U.S. industrial base. The format for this survey consisted of formal briefings and discussions on best practices and problems.

Time was spent on the factory floor at MDA reviewing practices, processes, and equipment. In-depth discussions were conducted to better understand and document the identified practices and problems.

Demonstrated industry-wide problems identified during the Best Manufacturing Practices surveys may be referred to one of the Navy Manufacturing Technology Centers of Excellence. They are identified in Appendix C.

### 2.3 COMPANY OVERVIEW

McDonnell Douglas Aerospace-West located in Huntington Beach, California, is comprised of three main business units - transport aircraft, space systems, and defense and electronic systems. The company employs more than 6,500 people in facilities covering over 228 acres.

In the transport aircraft unit, the primary focus for MDAC has been the C-17 cargo aircraft for the U.S. Air Force. In the defense and electronic systems unit, emphasis is placed on laser systems, surveillance and detection, information systems and strategic defense. The unit is also responsible for designing and producing avionics and ground support electronics for military and civil aircraft, missiles, and the Delta launch vehicle.

In the space systems unit, MDAC-W concentrates on the launch vehicle business, Work Package 2 of NASA's Space Station Freedom, and research and development in single-stage rocket technology and space exploration. The space station unit is a division of the space systems unit and is part of a five-company contractor team that is designing and developing a major component of the space station. The space system's advanced programs and technology division is developing a single-stage-to-orbit vehicle for military and commercial applications.

### 2.4 ACKNOWLEDGMENTS

Special thanks are due to all the people at MDA whose participation made this survey possible. In particular, the BMP program acknowledges the special efforts of Mr. Fred Riggs and Mr. Gerald C. Janicki for enabling this survey to occur.

---

## **2.5 COMPANY POINT OF CONTACT**

The information included in this report is descriptive of the best practices and techniques observed at MDA; however, it is not all inclusive. The reader will require more detailed data for technology transfer. This data is available through the survey point of contact. The point of contact for this BMP survey is:

Mr. Fred Riggs  
Senior Manager, Manufacturing Technology  
McDonnell Douglas Aerospace  
Internal M/C 45-2  
5301 Bolsa Avenue  
Huntington Beach, CA 92647-2099  
Phone: (714) 896-2997  
FAX: (714) 896-2997

---

# SECTION 3

## BEST PRACTICES

McDonnell Douglas Aerospace has rededicated itself to quality in every aspect of its business, from advancing TQM concepts to concurrent engineering efforts. A commitment to develop and invest in its core technologies and advance these in a shifting market environment supports the company's re-emphasis on quality. These aspects of the MDA environment were evident to the BMP survey team and were manifested in the enthusiasm of the personnel and the quality of the presentations. Therefore, the survey team considered these practices to be among the best in industry and government.

### 3.1 DESIGN

#### DESIGN REQUIREMENTS

##### Electronic Development Fixture

McDonnell Douglas Aerospace (MDA) effectively uses an electronic development fixture (EDF) (Figure 3-1) - a three-dimensional digital model - which allows synergistic

use by the weight, thermal, strength, logistics, and production engineers in development of Space Station Freedom for NASA. Design and manufacturing disciplines, as well as customers, have access to the latest digital product model and concurrently work to ensure that the model is accurate and complete.

By adopting a digital approach to modeling, costly mistakes are avoided resulting in reduced development time. The Unigraphics-based CAD/CAM/CAE system allows users to electronically investigate fit, form, function and interference detection. This is the primary tool for analysis, tool and support equipment design, wire harness and fluid tube development, and direct hand-off to the computer aided manufacturing processes. Tubing and wire harness drawings are produced automatically from EDF centerline routing data. The database is also used to facilitate assembly instructions, illustrated assembly and maintenance aids, factory layout, and part packaging. Parts manufacturing is automated by generating NC code from solid models that reside in the system.

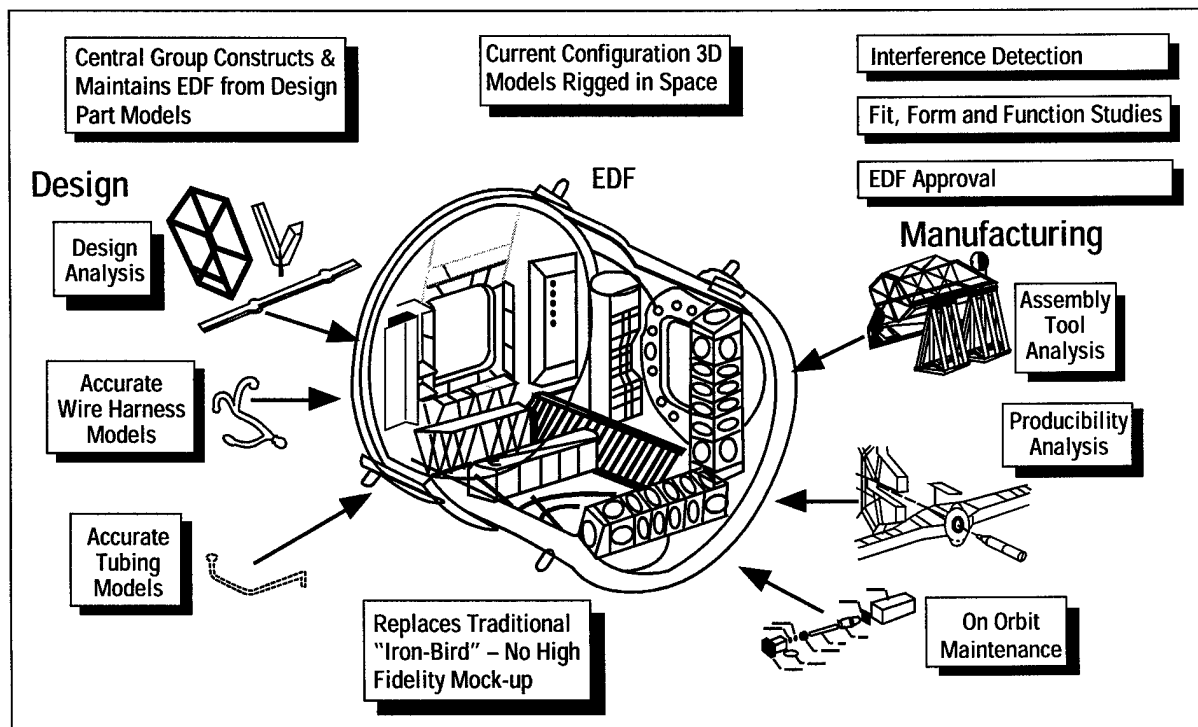

FIGURE 3-1. ELECTRONIC DEVELOPMENT FIXTURE

Once Space Station Freedom is complete, NASA can use this model for logistics support, training, modifications and technological enhancements. Other industries can benefit by concurrently using CAD/CAM resources to reduce cost and product development time.

## DESIGN POLICY

### CAD/CAM/CAE Unigraphics II

MDA-West has successfully evolved from two-dimensional drawings to three-dimensional drawings over the last ten years for all design and analysis. Using the Unigraphics II CAD/CAM/CAE system, MDA-West migrated from two-dimensional drawings as the design goal to complete three-dimensional solid models. Creating three-dimensional solid models is now the company standard for design, and

other functional areas such as manufacturing and logistics can obtain their required information. This effort has facilitated MDA-West's Concurrent Engineering (Integrated Product Development (CE/IPD)) efforts since other engineering functional areas are brought into the product development process early.

In the early 1980s, the MDA-West drawing creation process was sequential. A functional area did not receive a two-dimensional drawing from design until it was completed. Each area would receive the drawing for check and approval (Figure 3-2). This process was time consuming because of the multiple iterations needed to obtain drawing approval by all functional areas. The CAD system was seen as an impressive drafting tool that at best reduced the time of the iteration process. Parallel check and review between functional areas was non-existent. Even though the Unigraphics system at the time had other capabilities, it was not

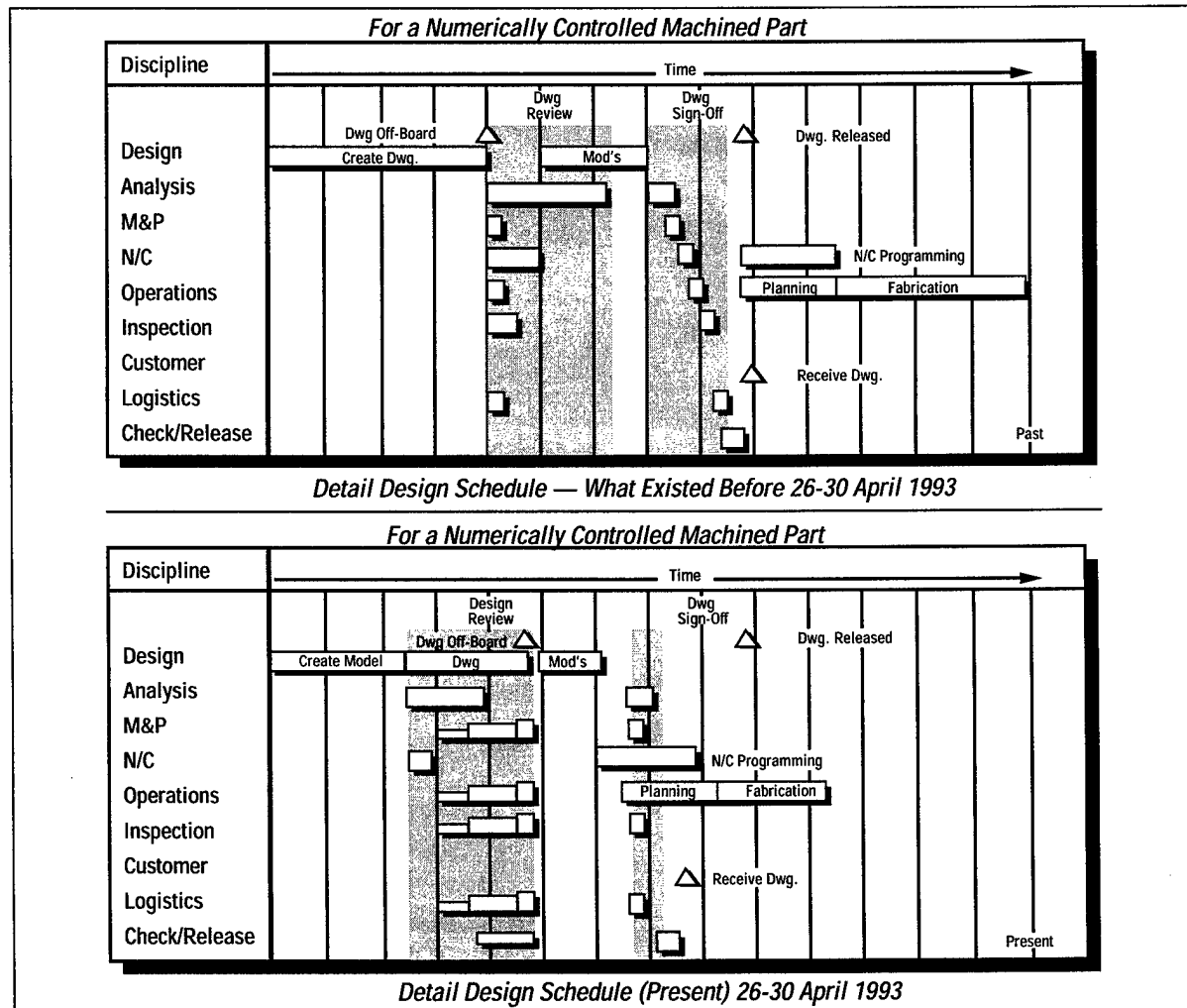

**FIGURE 3-2. DETAIL DESIGN SCHEDULE - WHAT EXISTED BEFORE AND PRESENT**

fully utilized because many engineers were not trained in those capabilities.

MDA then created strategic plans for use and support of the Unigraphics system as a total tool for design creation, design analysis, manufacturing planning, and communication between functions. Unigraphics was seen as a tool to facilitate company wide Concurrent Engineering/Integrated Product Development (CE/IPD). A Unigraphics advisory team was created to guide the integration of the Unigraphics tool with the CE/IPD strategic plan. The rapid development of computer hardware technology eased the integration of the CAD/CAM system with the strategic plan. In-house training programs were started for Unigraphics and focused on instructing the engineer how to use the specific Unigraphics modules required to complete the job.

MDA-West currently uses Unigraphics three-dimensional, solid or wireframe, models as the baseline for all engineering. Model data is digitally communicated with other areas. Two-dimensional drawings are created from the three-dimensional model as needed. This transition phase will continue until all engineering functional areas use three dimensions.

Parallelism is accomplished through the use of Unigraphics as a tool for all functions to be directly involved with the model creation from early in the design process (refer to Figure 3-2). Sequential hand-off of drawings for signature release has been minimized with sign-offs often occurring in parallel.

The attempt to marry the Unigraphics CAD/CAM/CAE tool with the CE/IPD thrust at MDA-West has proven to be successful, and MDA has determined several important lessons from this effort including that the management buy-in to change needs to be quicker; the engineering design time increased but the overall project cycle time decreased; there is still a need to drive down Unigraphics capabilities to suppliers; and there is a need to improve electronic communication links between functional areas. The Unigraphics tool has been tremendously effective in achieving the CE/IPD success seen today at MDA-West. Great time savings have occurred due to early feedback on design issues across disciplines, parallel interaction between teams, and improved access to design information.

## DESIGN PROCESS

### Integrated Product Development

Integrated Product Development (IPD) multi-functional teams provide the communications interaction foundation for concurrent engineering efforts at MDA. The teams are augmented with integrated design and manufacturing support systems that create the environment for near real-time concurrent engineering.

Market competition, driving the need to improve quality, reduce cost, and shorten cycle times, prompted MDA to aggressively pursue concurrent engineering. While MDA has practiced concurrent engineering over the years, top corporate management recently re-emphasized its policy to build the product right the first time, every time. This re-emphasis, coupled with integrated CAD/CAM systems, provided a supportive environment for concurrent engineering. Management demonstrated the backing of its policies through organizational restructuring, and the company has moved away from functional organizations toward IPD teams that operate in a flexible matrix. IPD efforts focus on eliminating functional communication barriers or "silos." As a result, IPD provides the framework for MDA's concurrent engineering efforts. This effort is a holistic, systematic approach encompassing the entire life cycle development effort from concept through disposal.

CE/IPD strategic and tactical plans cover several DoD initiatives and instructions such as DoDD 5000.1 and DoDI 5000.2, Defense Acquisition Management Policies and Procedures, Total Quality Management System, Computer Aided Acquisition and Logistics (CALs)/Contractor Integrated Technical Information Services (CITIS); DoD 4245.7M, Transition from Development to Production; and MIL-STD-499B, System Engineering. In addition, the plans provide a support structure (Figure 3-3) for training, advising, measuring, scheduling and facilitating the IPD teams.

MDA has simplified CAE/CAD/CAM support tools by standardizing Unigraphics design and manufacturing software that runs on the HP 700 series workstation and by standardizing Macintosh desktop computers on the Space

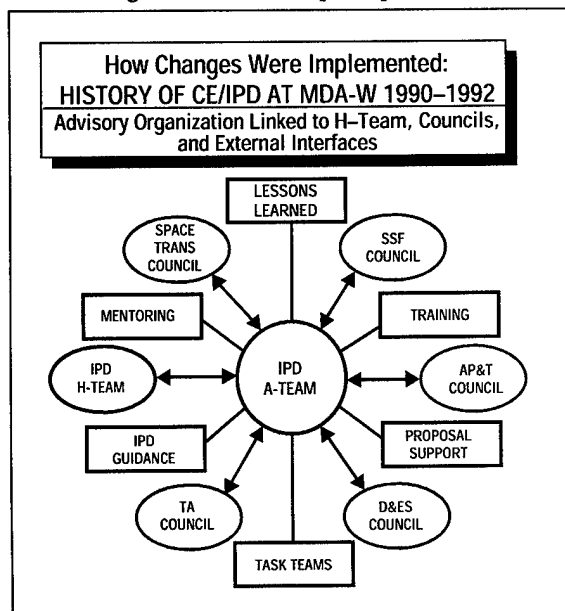

FIGURE 3-3. CE/IPD DEPLOYMENT

Station Freedom program. MAC-X provides a shared-x window into the Unigraphics files stored on DEC VAXs. The network of mini-computers, workstations, and desktops enable near real-time CE/IPD for local, as well as for geographically separated, activities. Therefore engineers, technicians, manufacturing, and logisticians share ideas throughout the design, development, and manufacturing cycles regardless of personnel location.

CE/IPD represents a common sense approach to proceed with the right thinking up front and promote all possible parallel actions. This common sense approach to CE/IPD deployment has provided several benefits including:

- An increased efficiency through early up-front communications;
- An awareness of downstream needs of all customers;
- An enterprise product ownership because of team involvement;
- A reduction in non-value added activity;
- An establishment of contact networks between suppliers and teammates;
- A higher first-time quality in all program phases;
- An increased use of shared data;
- A reduction in part counts through robust design principles;

- A higher performance achieved on schedule with less rework; and
- A reduced life cycle cost.

CE/IPD supports the TQM philosophy. It is a methodology, a philosophy, and a mind-set that helps teams of product developers define all aspects of a product's life cycle from concept through disposal.

## DESIGN ANALYSIS

### Underwater Test Facility

MDA is strongly committed to the development of space systems. However, a difficult space system design challenge is the requirement for operation in zero gravity conditions. Human factors such as personnel safety are of critical concern, and methods for assessing the impact of various design aspects in zero-gravity therefore become integral. MDA addressed this concern by constructing an Underwater Test Facility (Figure 3-4) at the Huntington Beach location. This Test Facility is built around a 70-foot diameter by 35-foot deep freshwater tank that holds almost one million gallons of water. The size of this tank allows large, complex mechanical structures to be completely submerged and buoyed to simulate zero gravity. Divers, buoyed in a similar manner, can help evaluate the ease with which assembly or maintenance is performed on the structure.

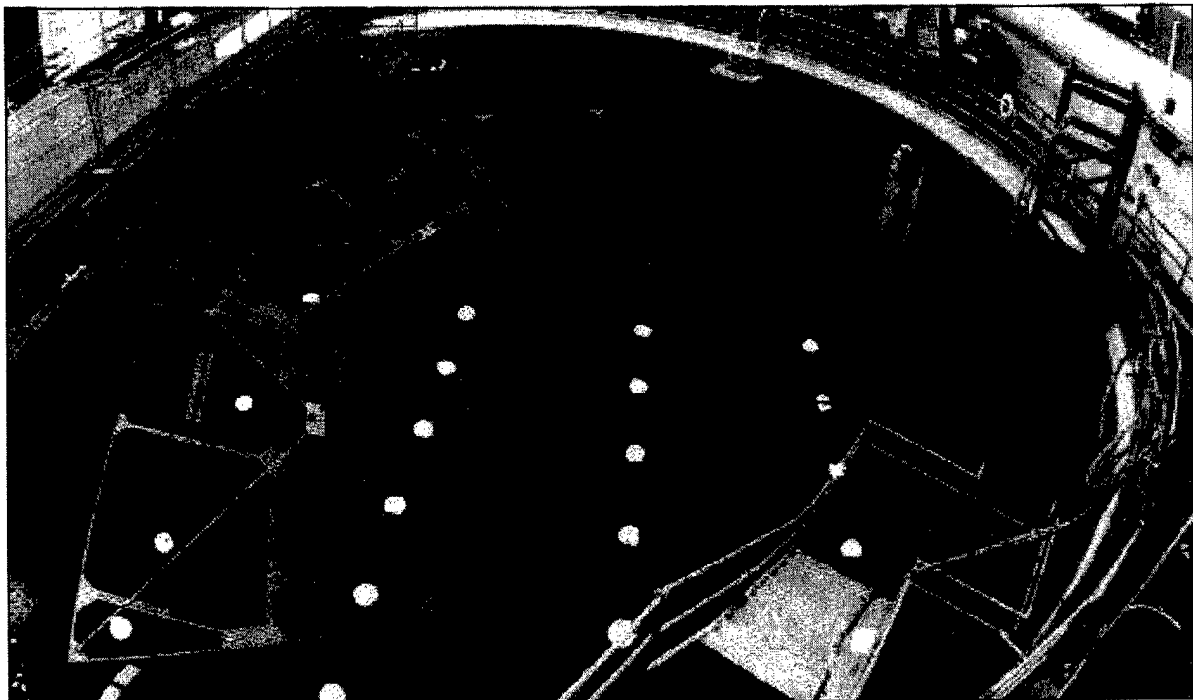

**FIGURE 3-4. UNDERWATER TEST FACILITY**

Instrumentation of the Underwater Test Facility includes two-way, two-channel communications, nine video tape recorders, as well as several cameras and monitors to capture a variety of viewing angles. In addition to the evaluation of human factors for design, the tank can be used to evaluate performance dynamics of autonomous, remotely controlled, and tethered equipment and systems.

The Underwater Facility has enabled MDA to design tools that are easier to handle and operate. Work platforms have been designed to provide workers support and leverage - prime areas of difficulty in space operations. The time required for each task can also be more accurately measured, facilitating properly planned work schedules around fatigue factors and other restrictions such as total time for Extra Vehicular Activity.

## CONFIGURATION CONTROL

### Electronic Change Control

Electronic Change Control (ECC) is part of the enabling technology support system for Concurrent Engineering/Integrated Product Development (CE/IPD) at MDA. ECC is an on-line system accessible throughout MDA for tracking and controlling engineering changes. The system supports parallel activities and simultaneous multiple users within the change control process (Figure 3-5). ECC exemplifies MDA's commitment to CE/IPD and its dedication to maintain a leadership role in the aerospace industry.

A major advantage of the integrated ECC system is the ability for drawings developed on Unigraphics workstations to be displayed on Macintosh desktop computers. The ECC system user friendliness is provided through a variety of hierarchical menus that allow functionalities such as:

- Entering and viewing drawing changes;
- Establishing and displaying review lists;
- Notifying reviewers via electronic mail;
- Providing password schemes;
- Handling change rejections and comments;
- Retrieving and displaying approval histories;
- Searching for various types of data for comparisons;
- Listings for project change notice status and reports; and
- Charting and graphics.

Many benefits have been derived from the ECC system. The system reduces cycle time in the engineering document review and approval by parallel electronic distribution. It also provides management visibility on tracking the progress of drawings in the review cycle, as well as the capability to convert all types of engineering documents into an electronic format for electronic distribution for review and approval. It can provide the capability to extract reports for

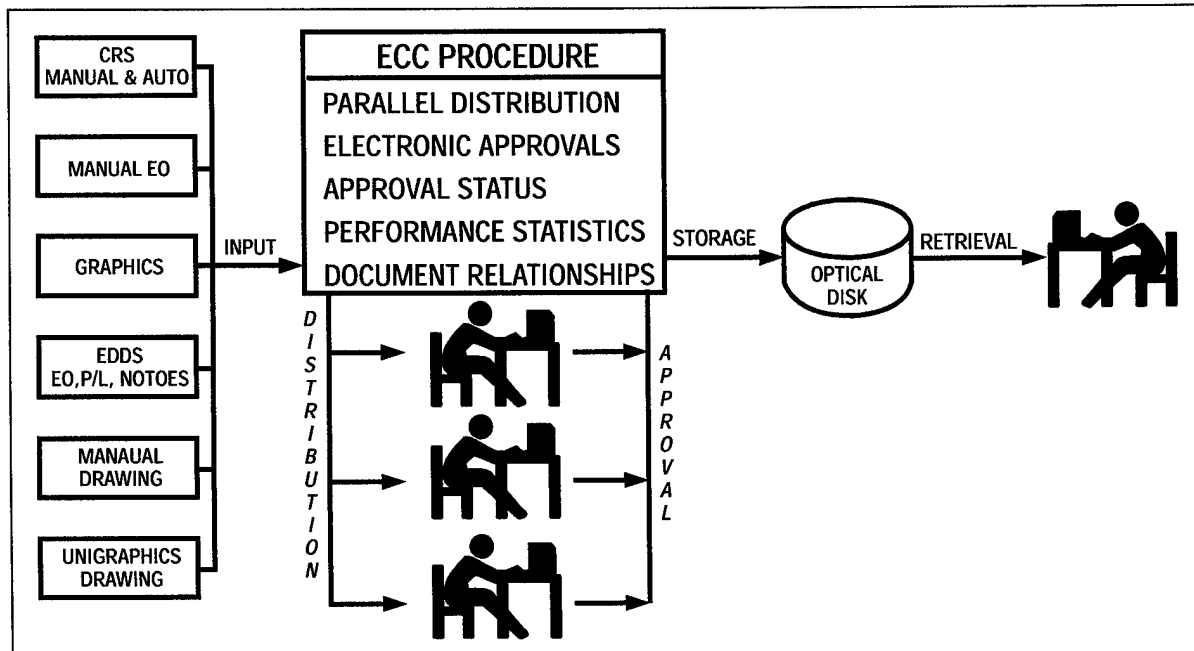

FIGURE 3-5. ECC PROCESS

---

metrics data. Documents are stored and exported in CALS compliant format.

## CONCEPT STUDIES AND ANALYSIS

### Strategic Technology Management

The goal of the MDA's Advanced Technology Program (ATP) planning process is to develop a method to successfully compete in future technology and advanced programs while minimizing the advanced technology development costs.

ATP provides a process for addressing the issue of where to direct research and technology dollars that will maximize the company's competitive edge. The system attempts to maintain a balance between advancing existing critical core technologies and developing new technologies while minimizing investment risks. An in-depth scoring system has been devised for effectively partitioning MDA's new business funds.

The following factors are considered, weighted, and traded to meet the corporate stated goals:

- Alignment with the strategic business objectives;
- Alignment with customer's initiatives;
- Program strategic category (defined in the strategic plan);
- Technology requirement date;
- Criticality of the technology to mission success;
- Make or buy positions;
- Competitive position; and,
- Technology requirement level (current versus required at the technology requirement date).

MDA has been able to prioritize technology requirements for product improvements and new products. It has also prioritized technology investment directions that are based on objective evaluation.

## PROTOTYPE DEVELOPMENT AND REVIEW

### Rapid Prototyping of Small Parts

Technical specialists at MDA have investigated two similar rapid prototyping technologies for producing small, complex-shaped prototype parts such as nose cones. Stereolithography (SLA) involves the use of a photo sensi-

tive polymer bath from which plastic prototypes are created using a laser for the polymer curing. Another technology, referred to as selective laser sintering (SLS), uses a powdered wax that is sintered with a laser to create a replica of the part to be made via investment casting. Both rapid prototyping technologies can produce parts in a fraction of the traditional time. These technologies also have a reduced overall cost per prototype.

Prior to the advent of rapid prototyping technology, MDA was dependent on a model shop with experienced machinists to build prototypes. While the model shop is still used, MDA employs rapid prototyping technology for some parts. The cost drivers for this effort include the intensive labor required to manually produce prototypes. The prototypes built with the traditional process often required many man-hours.

There are numerous service bureaus that produce SLA prototypes from CAD drawings. Also, there are SLA systems in St. Louis at McDonnell Aircraft Company, and at the Douglas Aircraft facilities in Long Beach. MDA-West has worked with both McDonnell Douglas SLA systems as well as with service bureaus, and one service bureau that produces prototypes with SLS technology.

Several lessons emerged from using rapid prototyping technologies including the fact that this type of rapid prototyping can produce successful models. There is a factor of 10 cost differential between the use of outside service bureaus compared to MDA internal cost and schedule to produce a part by conventional methods. The facet size used in solid model design impacts the surface finish of the prototype, and the accuracy of the design database is critical in obtaining an acceptable prototype.

MDA-West has confidence in producing dimensionally, accurate and functional hardware at low cost and short lead time. SLA and SLS will continue to be used for future part prototyping.

### Rapid Prototyping Simulation and Software

MDA applies over 30 years experience in simulation for design, including hardware in the loop. Guidance and control simulation reduces risk using performance assessment during design, and reduces cost by shortening development time. With the cost of a space vehicle launch, and the critical safety issues of manned space-craft, this simulation capability has become a necessity. MDA uses a spiral design process where iterative build stages are accompanied by iterative test stages.

The Rapid Prototyping and Integrated Design System (RAPIDS) was developed by MDA and Integrated Systems Inc. Using this system, build and test stages are concurrent

to shorten design time. Software code is automatically generated and documented from models, providing easy traceability between requirements and design. The RAPIDS software allows for six degrees of freedom simulated performance of air vehicles. Such factors as pitch autopilot, mission time, latitude/longitude flight path, and seeker operation are monitored and controlled. Automatic analysis includes non-linear time domain simulation and frequency domain stability analysis.

Modeling begins with the System Build Block Editor. This feature provides familiar block diagrams, unlimited hierarchy, full timing control, and precise design specifications. The hierarchy allows the use of generic function blocks for high level definitions with subsequent lower and finer levels of detail as the system is designed. Each block is cataloged and may be reused any number of times in any number of system designs. The models can then be exercised to simulate performance and assess model compliance with design requirements.

After a successful simulation, the Automatic Code Generator converts the block diagrams into complete, real-time software programs. The code is directly traceable back to the System Build module, and the program is portable to any real-time computer. The AutoDoc feature provides for automatic document preparation and is compatible with FrameMaker and Interleaf.

The next determination of system performance is made by downloading the code to the guidance and control processor and exercising it with an in-circuit emulator. When all testing is satisfactorily completed, actual vehicle hardware is added to visually examine performance.

RAPIDS has been successfully applied to full development projects such as the Single Stage Rocket Transport (SSRT), with more than a two-to one-reduction in system development cost. It facilitates an integrated team approach and sharing of knowledge. While the automated code generation is not a replacement for software development, it does produce error free code and saves significant time.

## 3.2 TEST

### DESIGN LIMIT

#### NDT Analyses/Equipment

MDA employs non-destructive evaluation methods to examine manufactured assemblies for defects in material or workmanship. Hand-held probes are used to detect eddy currents that may indicate material anomalies. Hand-held acoustic probes are also used, such as the QFT-2 portable acoustic scanner from Dupont™. MDA also has special X-

ray equipment to perform computed tomography and real-time radiography. Figure 3-6 presents several pieces of this NDT test equipment.

New composite structures must be evaluated to determine suitability for potential new designs. Surface flaws can be detected by die penetrant, but sub-surface flaws are typically scanned acoustically. A C-scan of the material translates to X-Y plots of attenuation data, or A-scans can be displayed via oscilloscope. However, this may not accurately determine the depth or the location of the flaw. This was a critical problem for design of a helicopter mast mounted sight.

The NDT group at MDA has implemented a technique to address these issues. Developed with IRAD funding, the technique involves totally immersing the system under test in water. Signal sources are placed opposite each other on each side of the structure using a six-axis positioning system.

An ADIS test system is used to initiate acoustic pulses to establish a performance baseline of the immersed structure. The ADIS equipment has several notable features including an 85 decibel acoustic dynamic range, special programming features to allow fine tuning of test settings to help evaluation, and automated documentation. This automated test system combines several acoustic scanning techniques to present a three-dimensional image that can be analyzed for accurate defect location and defect type.

Since its first use in the mid-1980s, the ADIS Automated Acoustic Analysis System has been used on numerous composite structures to evaluate material performance. The information provided has significantly contributed to safer designs for piloted systems and has resulted in cost savings more than double those originally estimated.

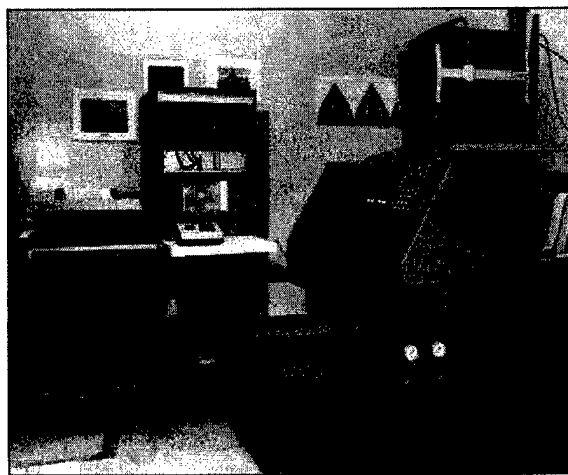

FIGURE 3-6. NDT EQUIPMENT

## Automated Load Programming System

Design and test engineers at MDA have found that sharing part models in the early stages of product development offers a rapid and flexible means of verifying early design concepts. As part of a concurrent engineering approach to product design and development, mathematical part models that were automatically generated by design engineers using CAD models are utilized for structural testing of fabricated parts (Figure 3-7).

Early part models and analysis are available to test engineers across a distributed network. Parts are fabricated in early design stages and tested at the MDA structures laboratory. The five-test pads in this 200-foot diameter building are capable of resisting axial loads up to eight million pounds.

Horizontal and vertical loads are applied to parts using computer controlled actuators. Feedback from the loading process is used automatically in tuning the load applied to the test article. Up to 128 data acquisition points can be applied to analyze strain-load deflection to verify computer models. Parts are tested using this methodology until a destructive structure limit is found. Part analysis using the automated loading programming system can verify structural analysis and give designers a quick and accurate measure of maximum part capabilities and safety margins. All modeling, design, and analysis information is shared and can be remotely accessed through a distributed database architecture.

By integrating automated design and test analysis results into part development, mistakes and costly rework are avoided. Design engineers are given quick feedback and troubleshooting tools to ensure an optimal system design.

## TEST, ANALYZE, AND FIX

### Dynamics Laboratory

Parts analysis can be a complex and time consuming process for engineers without the use of a CAD package. By using models of parts, analysis of the dynamic properties of parts is automatic. Design engineers at MDA are sharing motion and stress analysis information with test engineers at the MDA Dynamics Laboratory.

Once rigid boundary conditions are established, torsional and linear forces are applied to test parts, and the resulting motion is analyzed automatically. I-DEAS software is being used to collect and analyze harmonics. In addition, the test software exaggerates part motion, helping engineers to visualize movement. Four views of the object under test are displayed electronically with resulting movement (front, side, top, and perspective). Bode plots can be created, and expected response can be compared with actual response. Both design and test engineers share analytical information across the MDA fiber optic network.

By comparing design and test analysis, engineers can ensure that stressed parts will behave as expected. Refine-

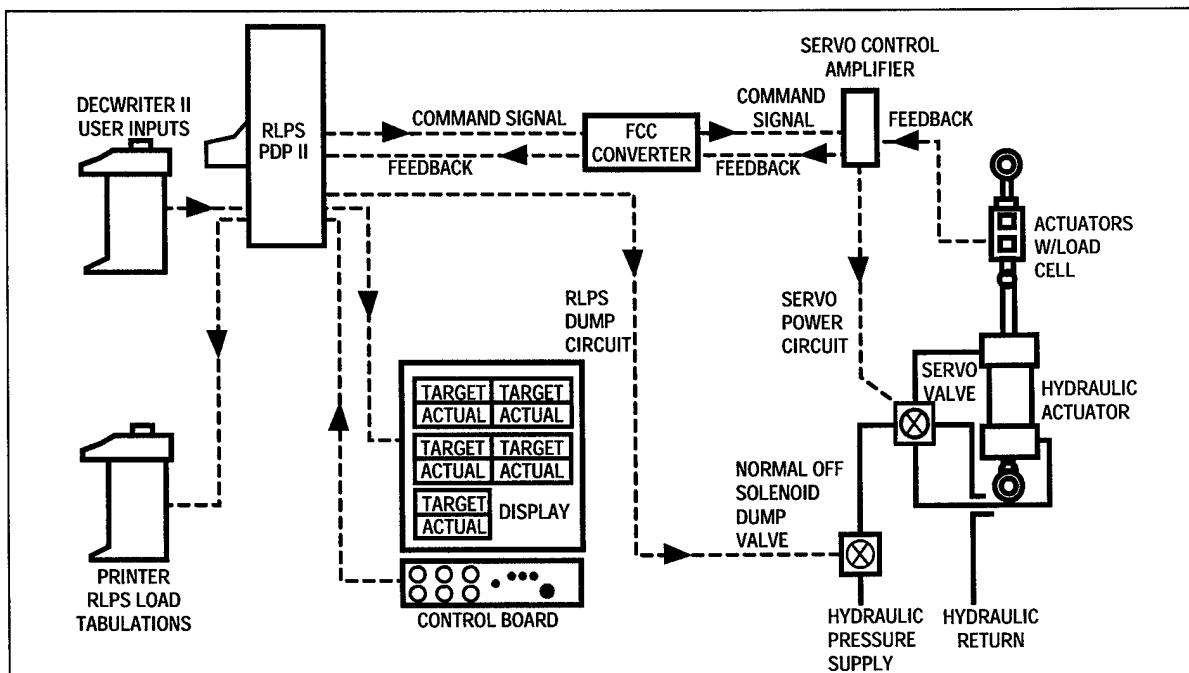

FIGURE 3-7. AUTOMATED LOAD PROGRAMMING SYSTEM

ments in design are made quickly and easily to meet system requirements.

### 3.3 PRODUCTION

#### MANUFACTURING PLAN

##### Rapid Prototyping for Single Stage Rocket Technology

The Single Stage to Orbit (SSTO) Program at MDA is part of the Strategic Defense Initiative. This program will enable space travel that is quick, simple, and cost-effective with no consumable parts, and maintenance schedules similar to conventional aircraft.

The Single Stage Rocket Technology Program (SSRT) has successfully implemented the government/industry integrated product team approach to achieve a rapid prototyping design, build, assembly and test of the Delta Clipper experimental vehicle (DC-X) (Figure 3-8). The DC-X is a

one-third scale pre-prototype version of the final operational single stage to orbit vehicle. The design, production, and flight of the DC-X aids in the design, production, and flight of the final, full size Delta Clipper. The DC-X, together with its ground systems for remotely handling cryogenic liquid hydrogen and liquid oxygen and its totally autonomous flight controls and flight operations control center, was completed in two years at a cost of \$58 million. This was accomplished by creating an empowered project environment through which small teams focused on the rapid delivery of a quality product. The design was driven by operability and supportability and the need to use existing technology and components through which all SSRT rapid prototyping department activities were executed. The team was guided into this project by the SSTO Rapid Prototyping Procedures.

This working document was "bought into" by the heads of engineering, operations and quality divisions early in the program. A training session was conducted with the entire SSRT team which familiarized all personnel with the design,

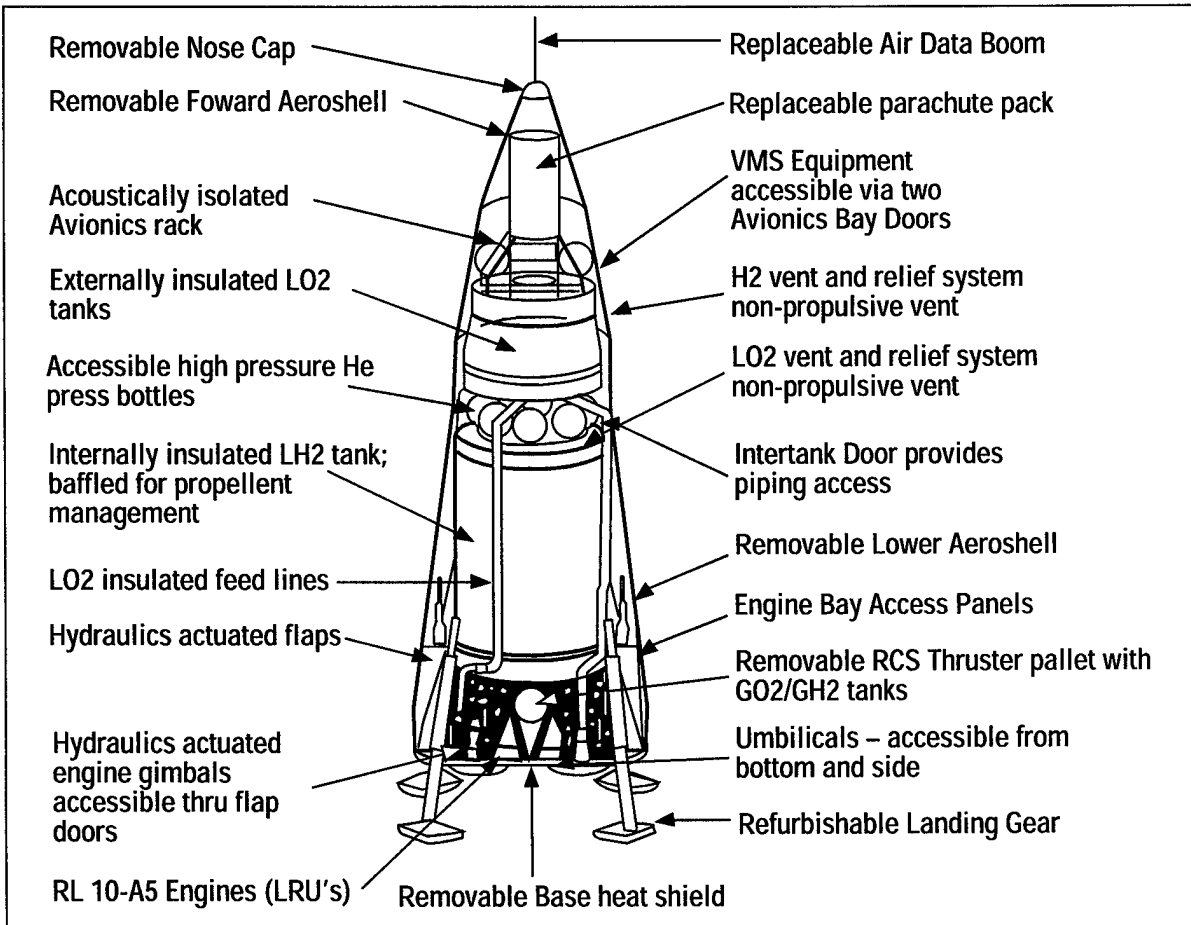

FIGURE 3-8. DC-X VEHICLE

production, assembly and quality procedures to be used throughout the project. From the start of the design, engineering, supportability, test and manufacturing personnel were located in the same area and together with procurement and business management worked the same hours. Each discipline was able to ensure that its requirements were incorporated from the start and that development and delivery schedules were compatible. Throughout the process, engineers were empowered to make real-time changes without oversight by project administration. A material manager for subcontracts and procurement was part of the team and able to provide support to the team and the suppliers.

Requirements for hardware procurement and related support items were generated by advance material orders to avoid impacting production schedules. One item that helped this project's success was the creation of a petty cash fund of \$3,000. This expedited necessary immediate purchases and aided in cost and schedule compliance. All material purchased was delivered directly to the SSRT program and incoming quality inspections were conducted only when deemed necessary on a case-by-case basis. This approach was facilitated by broadening the inspection responsibilities of the suppliers.

Internal quality inspections were reduced because technicians were empowered to inspect their own work and the work of others. To eliminate potential problems with union classifications, a dedicated assembly department was created with one job classification. This department was made up of skilled and motivated personnel with a mixture of classifications and labor grades.

MDA successfully prototyped the DC-X because it was able to identify and had top management support to implement the necessary requirements for rapid prototyping. Key in this support was that of the customer who empowered his industry team to carry out all functions required to implement the program goals and provided the necessary government support, where needed. Other key features of the team were: Establishment of a set of shared global requirements; a highly motivated team with these common goals; a trained and empowered workforce; responsibility, accountability and authority assigned to team members; integrated product development teams (including government team members); and the commitment of management and union throughout the project. By implementing these elements, MDA was able to carry out the successful rapid prototyping design to demonstrate operability, supportability and manufacturing as well as performance.

## **SUBCONTRACTOR CONTROL**

### **California Supplier Improvement Program**

Supplier-provided parts and materials represent 50%-75% of the products delivered by MDA. As a result, MDA

wants to conduct business with well-trained, well-equipped, and modern aerospace suppliers. In an effort to improve the selection of good suppliers with which to work, MDA joined the California Supplier Improvement Program (CalSIP). The state of California, in cooperation with leading state defense/aerospace firms, initiated this program with the goal to develop suppliers that are committed to continuous improvement and understand and utilize the tools and methods of continuous improvement. It is advantageous for companies such as MDA to conduct business with these local suppliers, and the state of California benefits by retaining valuable manufacturing jobs.

The key features of CalSIP are a common curriculum, a consistent delivery system, low cost, and available state funding. The curriculum was determined by a group of defense/aerospace firms and represents their determination of the critical knowledge areas for suppliers. The curriculum consists of TQM, JIT, SPC, and team building and empowerment skills.

The CalSIP process begins by attendance at a workshop at a local community college for a small fee. The workshops cover the fundamentals of the previously mentioned areas. The next step is to conduct a self assessment using the CalSIP assessment criteria. The third and final step is to receive on-site training from designated CalSIP trainers to help establish and implement the elements taught in the curriculum.

To qualify for assistance funds from the state of California, a supplier must be a supplier to the defense/aerospace industry, employ less than 250 people, contribute to the unemployment insurance fund, and have training that is critical to the continued employment of workers.

If a supplier does not qualify to this criteria, it can still receive the training; however, all costs incurred are at its own expense. The completion of CalSIP training does not equate to achieving certified supplier status for MDA or any other major defense/aerospace contractor. It will, however, make it easier to achieve such certification.

## **COMPUTER-AIDED MANUFACTURING (CAM)**

### **Numerical Control Simulation/Verification**

MDA-West utilizes software packages designed for verification of NC programs that substantially reduce the proofing cycle of NC codes while improving first time quality and reducing costs. NC programmers generate programs from electronic engineering models, and these NC programs, run on Hewlett-Packard dedicated workstations, are simulated and verified using Vericut™ software available from CG Tech. The software demonstrates the programmed cutting of a solid model including cutting tools and parameters. This allows the programmer to verify the NC program results in a part configuration matching the engineering model.

MDA has also written software packages to ensure the correct tool definition is maintained through the program and correct procedures are used which are not included in the Vericut™ program. After verifying the NC program, a post-processor generates the specific machine control language. Because the generic data can be converted incorrectly resulting in invalid motion statements, MDA has created a reverse post-processor to verify the final code.

Implementation of this NC program verification system has greatly enhanced first time quality. Although the NC programmer spends approximately 10% to 25% more time preparing the program, hardware is correct the first time at a rate of 99%.

### Graphic Interactive Programming

Graphic Interactive Programming (GRIP) began at MDA in 1990 as a project to improve quality, reduce lead times and hard tooling dependency, and to apply standardization to the manufacturing process of various selected extruded parts. It replaced conventional milling and drilling operations and eliminated the need for new set-ups for different part runs on the shop floor.

All manufacturing data is now delivered to the machine work center through a VAX-based DNC network. The operator on the machine uses a VAX station 3100 with a 19-inch color monitor to obtain the NC program, set-up and manufacturing data, and the cutting tool list. GRIP is menu driven and requires the operator to respond to basic questions about the part. It has built-in machining parameters, cutting tool selections and set-up options, and electronically displays all information to the operator based on the part information.

The software was produced in house as a "hook" to obtain the CAD/CAM data and to take advantage of several sub-routines in the manufacturing process. By applying GRIP to a specific three-axis NC machining center, MDA has reduced the manufacturing cycle time by 71% with a less than 1% rejection rate. There are currently over 1,300 part numbers in the database for this work center. By using GRIP in the work center, MDA is prototyping a paperless factory while consistently building parts to engineering requirements and standardized methods. Parts that are produced in this work center are no longer dependent on the skills of the operator and costs have been reduced while improving quality.

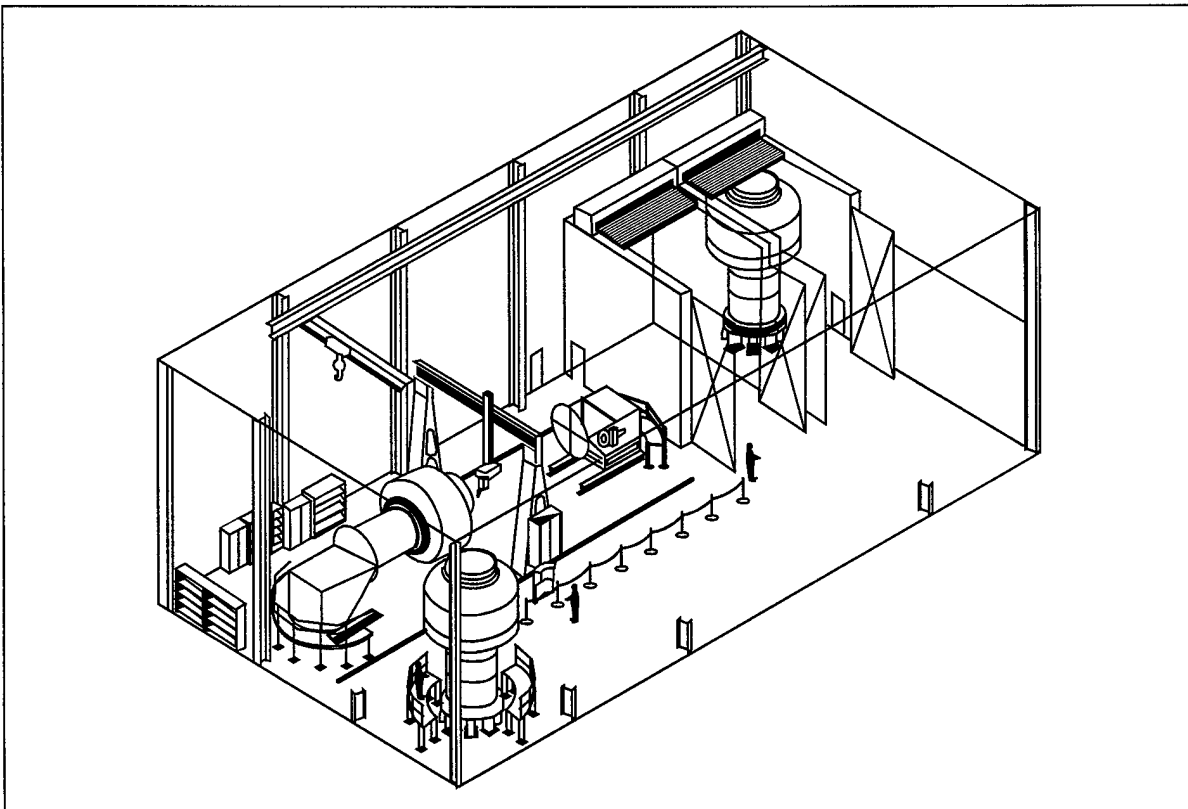

**FIGURE 3-9. VPPA WELDING AND INSPECTION**

---

## PRODUCTION FABRICATION

### Aluminum Welding Practices

MDA has previously successfully welded aluminum alloys with gas tungsten arc (GTA) and gas metal arc welding processes. Now, the company-wide commitment to quality has provided the catalyst to invest in a state-of-the-art variable polarity plasma arc (VPPA) welding and inspection facility (Figure 3-9). This dedicated weld development facility consists of 7,200 square feet of high bay and 7,600 square feet of low bay space meeting class 100K clean room requirements.

The facility has two radiographic inspection booths. The VPPA welding cell consists of a computer-controlled 400 AMP Sciaky weld system capable of plasma or GTA welding in straight or variable polarity modes. Integrated into the weld controller is an MVS laser-based automatic weld joint tracking system, remote controlled mechanized filler wire guide, and a pre-weld and post-weld color video viewing system. The welding controller is capable of controlling and monitoring 23 selectable welding parameters with electronic or hard copy recording of actual critical welding parameters for a given weld sequence. The cell provides nine axes of motion, seven of which are computer controlled. The work envelope is 18 feet wide by 50 feet long with two, 30,000 ft-lb torque positioners. A 7,500 pound overhead bridge crane supports manipulation of hardware in the facility.

The VPPA welding and inspection facility combines state-of-the-art welding equipment and controls with tooling, providing the capability to join large structures in an environmentally controlled facility. This effort produces high quality, low cost manufacture of aluminum structures.

### 3.4 FACILITIES

#### MODERNIZATION

##### Separation Rail and Attenuator Tube Center

MDA has developed and installed a self-sustaining manufacturing cell for fabricating the hardware used in a rocket fairing separation system. Prior to the cell's development, various parts were manufactured and fabricated in several different shops throughout the complex, resulting in long queue times, low performance, slipped schedules, and poor quality control.

This area - the Rail and Attenuator Tube Center - now controls the manufacture and inspection of various parts that comprise the separation system as well as the

assembly of the attenuator tube. Major cell equipment consists of a CNC drilling machine, a CNC vertical machining center, two EDM machines, and various tube flaring and bending equipment used to form the tube assembly.

All equipment is dedicated to the parts that comprise the separation system assembly. Repetitive part manufacturing within the cell has resulted in first time quality improvements as well as productivity gains. Consistent process control is now achievable, and process improvements can be readily applied and quickly measured. Future plans include adding part families to the cell as the customer base grows. Because the parts no longer are shifted through the various shops, cycle times and damage due to handling and transporting has been significantly reduced.

##### Factory Rearrangement

Prior to the late 1980s, MDA practiced reactionary factory facilities management. Under the system, operations departments would identify and submit their requirements to the facilities department. The requirements would then be analyzed, and the request would be denied or implemented. This cumbersome system led to conflicting requirements, less efficient use of existing facilities, incomplete project scope and justification, weak budget discipline, missed need dates, no concurrence in approach, and general customer dissatisfaction.

Several factors created the opportunity to change this facilities management philosophy. These factors included new program starts, the MDA reorganization, and McDonnell Douglas' commitment to concurrent engineering. The Vice-President of Operations and Vice-President of General Services therefore empowered a new Factory Rearrangement Team leadership to provide a focal point for all current and potential factory requirements, and provide options and recommendations necessary to meet those requirements.

Under the new process, requirements are now submitted to the factory rearrangement team for analysis. The request is analyzed for resources, scope, and schedule. Options and recommendations are presented to the Vice-Presidents of Operations and General Services, and a team oriented decision is achieved. The operations membership responsibilities are complete when facilities implements the plans.

Benefits derived from the Factory Rearrangement Team concept provide customers with systematic processes for obtaining factory space, high level visibility to area allocation issues, encourage open flow of communications between facilities and operations, enhance concurrent engineering practices, and a low-level backlog.

---

## **FACTORY IMPROVEMENTS**

### **Facilities Benchmarking**

In December of 1989, the Facilities Planning group at MDA-West and the Facilities Director identified key performance measures in several facilities functions that affected the cost of operating and maintaining the facility. The group decided to conduct a competitive comparison between its facilities operations, other McDonnell Douglas Corporation operations, and outside companies. Prior to executing this comparison, the Huntington Beach facility gathered substantial data on its operation and noted industry trends from magazines/newspapers.

Possible options for conducting a non-McDonnell Douglas key performance comparison effort were examined, and it was concluded that a consultant would be selected to assist in a benchmarking effort. The consultant selected for the project was J.L. Balderston. Basic Facilities operation data sheets were supplied; facilities cost and performance data input was entered on the data sheets, and the consulting company performed the data compilation and analysis.

Companies that participated in the benchmarking study included all corporate divisions and five non-corporate companies, one of which was a Malcolm Baldrige award winner and another which had won the Deming award. Representatives of all companies meet twice a year to discuss and share best practices used. Follow-on site visits/meetings occur regularly between companies that focus on a specific area/operation.

Results of this benchmarking study indicated that non-aerospace companies had similar operations, and that companies share their lessons learned, thereby helping to avoid possible delays in pursuing superior performance. Through the benchmarking process, significant cost savings and cycle reductions are achievable while maintaining or increasing customer satisfaction, and true measures of productivity can be determined.

Since the incorporation of lessons learned in this benchmarking process, MDA has been able to consistently reduce building maintenance cost, utilities costs, and total site operating costs. Additionally, three separate benchmarking groups have been formed and are in operation including the National Benchmarking group, the corporate benchmarking group, and the Aerospace Benchmarking group. Each of the members of these groups are helping each other to maintain a competitive position in their respective industry.

### **Advanced Composite Technology**

MDA recognized that improvements were needed to become competitive with outside sources in composites manu-

facturing. The Advanced Composite Technology (ACT) area at MDA was affected by problems common to composites manufacturing including the perceived high fabrication costs, full design drawings, formal specifications, and overstaffed supervisors. The company discerned that to go to outside manufacturers would result in loss of the technology base.

To ensure composite manufacturing would become a viable assembly process within MDA, a new philosophy was developed which included minimum engineering formality, low cost production methods, concurrent design and manufacturing, fixed price bids, and personal responsibility for results. To help reduce production costs, low cost tooling such as wood, fiberglass, and foam, was used. Simple fixtures were also used. Employees were motivated and empowered to make changes and inspections as they worked. Responsibility for success was placed at the worker level. Enterprising ideas were used, and the creativity of the entire team worked to its advantage. To help understand procedures, graphic instructions were used to supplement or replace written instructions.

The changes in the ACT program have shown that composite manufacturing is competitive. This has been demonstrated in the National Aerospace Plane, the SSRT program, and the Navy's Clementine program. Precedents have been set for future applications in fairings, cryotanks, and in the SSRT structure. The ACT, now the composite center for McDonnell Douglas Aerospace on the west coast, has developed in-house technology advantages.

### **Energy Efficient Cleanroom - Design Development**

In 1990, MDA initiated a facility project to construct a 30,000 square foot, high bay, Energy Efficient Cleanroom. Because this facility would be used by several customers, had a limited budget, and a long term effect on the facilities plan, the Facilities Group applied a new approach to ensure that all requirements would be met. Therefore, the traditional practice limiting the end user's involvement in the design process had to be changed.

The Facilities Group applied TQM principles to the process by forming a cross-functional team of the multiple intended users and all support organizations of the complex. An independent consultant then served as a facilitator in team meetings that addressed goals, facts, concepts, and needs in a process called Architectural Programming. The team was therefore able to establish common goals. Facts were gathered and analyzed, and concepts were uncovered and tested to determine the real needs of all users. The result of this effort was a problem summary manual which was developed by the consultant and used as the scope of work for the Design/Build Contract.

---

This structured process resulted in clearly defined requirements, first time quality, customer ownership, and provided a framework for timely decisions and early balance between requirements and budget. The facility is scheduled to be completed in July 1993.

### **Factory Improvement Team**

MDA approached the problem of capital equipment improvement and procurement by creating a Factory Improvement Team (FIT) to evaluate possibilities and provide recommendations. Typically a management function, capital improvement and procurement was not always an informed decision concerning equipment expenditures. Therefore, MDA created a team comprised of employees at the worker level who could easily recognize the needs of the facility.

Production capital equipment purchases are now consistent with effective utilization of space, maximum delivered quality, and return on investment. The FIT interfaces with the strategic factory area planning committee to achieve the highest possible return on invested assets. This process places the decision making responsibility with the employee instead of management.

One improvement made by the FIT was the purchase of a computer-aided theodolite system. It identified system applications such as periodic tool inspection, master model contour verification, and validation of flight hardware in the tool fabrication department. The FIT justified the need by showing a potential reduction in cycle times, reduced man hours, and increased accuracy. The theodolite system, a state-of-the-art method for measurement and alignment, operates by triangulation with targets sighted at the heads. Horizontal and vertical angles are collected and delivered to the computer, and the angles are calculated into three-dimensional coordinates. Cost savings realized from the purchase of this measurement and alignment system included a significant reduction of man-hours necessary for the master tooling on the windshield of the C-17 program. Another example of cost savings was on the MD-11 program. On this program, the nose aft-trim sawtrack tool inspection for misalignment and then realignment required an estimated 1,216 man hours. Actual process time using the theodolite was 158 man hours. A savings of 87% was realized on this process.

The FIT concept enables people with a clear view of the work and potential improvements to make recommendations concerning capital equipment improvements. The team is able to make decisions based on real needs rather than the perceived needs. This removes frustration from employees concerning allocation of funds for capital equipment improvements, and increases productivity, morale and ownership.

### **Optical Disk Data Records**

MDA-West was overburdened with the control and maintenance of paper documentation for its in-house programs including 20,000 pages and 200 customer requests per week. To alleviate this problem, the decision was made to utilize Optical Disk Storage capability for control/maintenance of the data.

Beginning in early 1990, four workstations were created for paper data entry into optical disk records. Data is now fed into the readers, and the total number of pages loaded on optical disks is 1,356,581. The present weekly average number of pages is 15,000. Overall productivity of information reading onto the optical disks has also been increasing, and MDA-West is conducting a study for upgrading the current optical disk system.

By implementing this data storage system, MDA-West has been able to eliminate lost documents, reproduce fabrications records in a timely manner; collect fabrication records in one database, and will eventually eliminate storing paper and reduce the overall storage cost.

## **3.5 LOGISTICS**

### **MANPOWER AND PERSONNEL**

#### **Technology Management-Resource Assessment and Planning**

MDA-West recently established Horizontal Teams and other management techniques for addressing common issues relating to resource assessment and planning. This implementation is several steps removed - and improved - from the common approach of matrix organizational structure.

During the mid 1980s, MDA-West migrated from a matrix structure to autonomous business and support units. Instead of core groups from a particular discipline supporting a program function, those functions had personnel with knowledge in a discipline permanently assigned to the program. This change in management structure however, resulted in a loss of enterprise-wide perspective of available technical talent.

The current organizational structure uses horizontal teams to support MDA business units, support units, and other key resources. For example, one of the primary responsibilities of the IPD Horizontal Team is to ensure professional and technical development and retention of MDA engineering and other technical personnel. The talent, knowledge, and capabilities of these personnel are key for successfully completing customer work and obtaining additional work from customers. To accomplish this goal, the IPD Horizontal Team established fourteen Technology Horizontal Sub-

Teams, each chartered to address enterprise-wide technology issues within each of the fourteen key Technology Areas, including the evaluation and skill retention of engineering and technical personnel. Each sub-team is composed of representatives from MDA-West organizations who had knowledge of the capability of the people in their organizations. Therefore, they were responsible for coordinating the talent pool in their organizations for key disciplines. This coordination includes the identification of key technical experts for skill retention.

These sub-teams, acting through a sub-team leader created a fourth generation database that contains the capabilities of all technical personnel. The information, collected on a Work Skills Self Assessment Survey, includes technical skills, education, assigned programs and projects, specialties within disciplines, and general data. All personnel surveys are entered into and permanently remain in the database. MDA-West uses the database to address issues and needs of specific technology areas, identify training needs, identify senior experts for apprenticeship programs, support staffing of proposals and programs, and promote technology sharing. All technical personnel have access to the database from Macintosh computers and can produce several types of reports.

### 3.6 MANAGEMENT

#### MANUFACTURING STRATEGY

##### Horizontal Teams

In 1989, MDA restructured its company, adopting a vertical, projectized structure, in an effort to improve business practices and more effectively organize its various business and support units throughout the company. A management decision to overlay a Horizontal Teams management approach developed from the need to assure commonality and integrity of processes and management systems as well as provide increased communications and shared decision making across each business unit.

The Horizontal Teams concept is based on assimilating individuals from various business units into a single team (Figure 3-10). The teams are tasked to review and improve the processes and systems that are used by all the various business units. As a result, an individual team member may spend a significant portion of time working to improve a process in a particular business unit that will have little or no effect upon the product that is delivered by that member's own business unit. However, the entire organization benefits

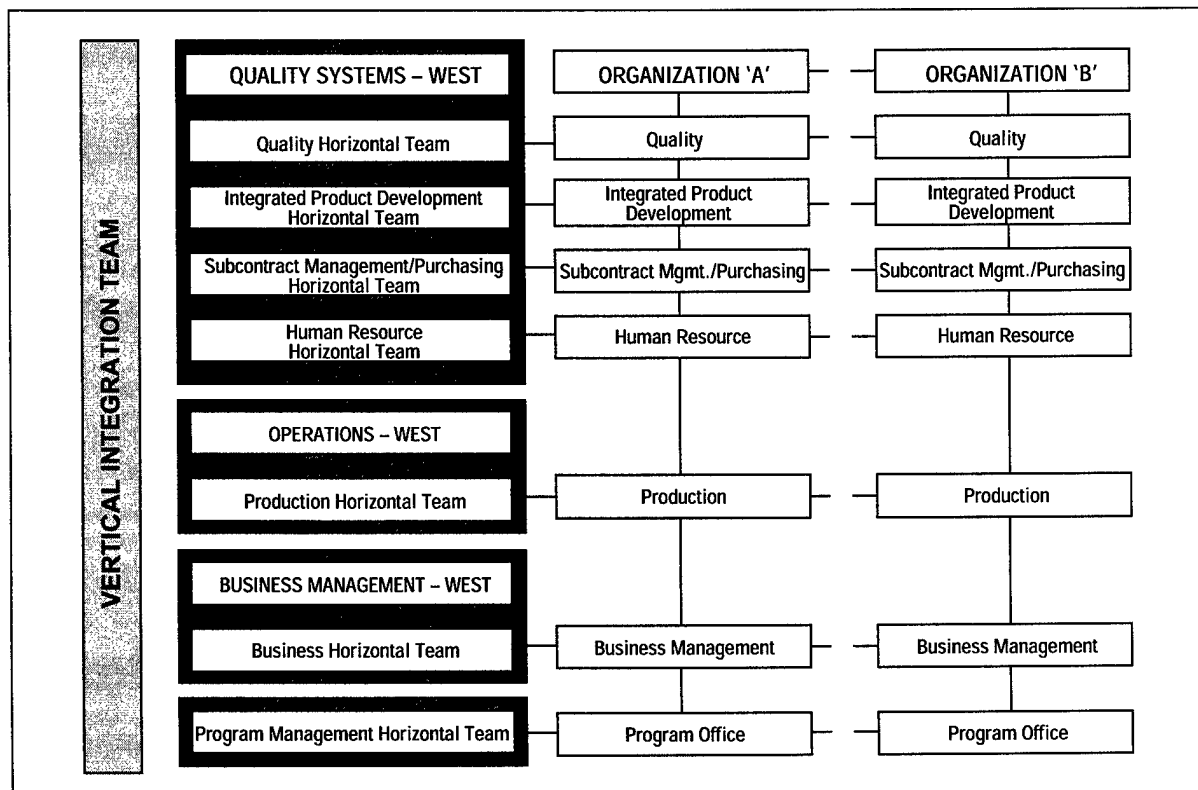

FIGURE 3-10. HORIZONTAL TEAMS STRUCTURE

from the synergistic effect and top-to-bottom process improvements instituted by these teams.

Seven Horizontal Teams were established - Business, Quality, Human Resources, Subcontract Management/Purchasing; Integrated Product Development; Production, and Program Management. The Directorate heads for each discipline within the business unit makes up each team, and personal participation is expected. Each team is assigned systems and processes with the responsibility and authority for ensuring that company-wide systems and processes are documented and meet customer requirements, as well as for installing the metrics to determine the health of those systems and processes. The reward and incentive systems have been modified to support this approach and were key factors in the success of the Horizontal Teams concept.

Sub-teams are routinely established to support the work of the seven Horizontal Teams. Each sub-team reports periodically to its own Horizontal Team with a standardized status report and progress against a milestone schedule. The Horizontal Teams are responsible to and report regularly to the Executive Council which is comprised of the senior vice-presidents and vice-presidents of each business and support unit.

MDA has realized a number of benefits through the use of Horizontal Teams including institutionalizing continuous process improvement. This is supported by the strong sense of system and process ownership by personnel who use them. Finally, there is a stronger focus on implementing practices that will help the entire MDA organization become more successful.

## Process Based Management

MDA-West directs overall manufacturing management through a seven-step process-based approach (Figure 3-11). Before this approach is implemented, a management team

defines critical process elements and prioritizes these elements to obtain a final assessment of process performance. This approach, unlike the conventional product-based approach, complements current quality approach initiatives being implemented by the Defense Logistics Agency which stress teaming and process-based management.

Process improvement is evaluated to assess how the seven-step management approach is performing. Reports are generated on a monthly basis defining acceptable levels and general status. These reports are submitted quarterly by MDA and DPRO to help define improvement plan status and DPRO concerns.

Some of the overall benefits obtained from this process-based management include:

- A one enterprise process for continuous improvement;
- Established common objectives for MDA-West and the DPRO;
- A consistent means to communicate status to product customers;
- A focused management attention on key customer-driven processes and priorities; and,
- Assimilated DoD TQM, DPRO surveillance and MDA-West quality initiatives.

## Survey of Organization

MDA-West uses a Survey of Organization (SOO) to determine the overall working atmosphere and assess the company's performance capabilities. The SOO is based on a comprehensive questionnaire that measures conditions and practices that affect the "bottom line." Completed by all employees, it is distributed, collected, and analyzed by an

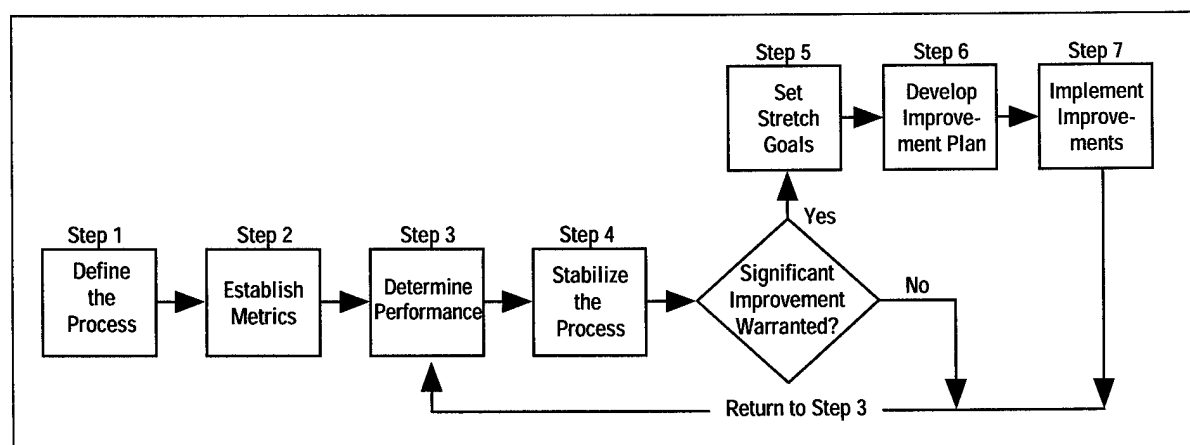

**FIGURE 3-11. SEVEN-STEP PROCESS BASED MANAGEMENT APPROACH**

---

outside firm to maintain the employees' anonymity on responses. The SOO applies an extensive bank of norms by level, functions, and industry with over 40 years of research underlying its validity and reliability. This tool allows the company to add 80 supplemental questions and can measure company climate, supervisory leadership practices, peer relationships, and individual and group performance.

MDA-West publishes the results of the survey so all employees know the results and can identify where areas of improvement are needed. Another unique aspect of this SOO is the Rebound Process - a formal mechanism for employees at all levels of the organization to ultimately impact company operation. This rebound-or upward-flow of information within the organization -is an often missing but very essential ingredient for an effective and not just efficient management organization.

MDA has determined that the keys to successful use of an SOO include:

- To clearly communicate its purpose to all employees and share with them the expectations for actions based on data received;
- To make the survey effective and non-punitively administered;
- To make sure it has broad participation - at MDA-West, the participation rate exceeded 92%;
- To be sure the data is consistently used across all business units;
- To conduct effective work group feedback meetings such as flowdown and rebound process; and
- That management must take visible and timely actions to improve the company at all organizational levels in response to the SOO.

The SOO must be seen as an avenue for actual change, not simply a measurement that is performed, then shelved. MDA-West learned this lesson and embodied this feedback process to implement change to the Executive Management level. Using this instrument provides advantages such as helping to accelerate cultural change; providing a basis for data-driven corrective actions both within individual work groups and in the organization as a whole; establishing a baseline for measuring improvement; evaluating employee perceptions at all levels; and providing data for company benchmarking in useful categories.

### MDA-West/DPRO Customer Relations

Improvement to the process of MDA-West's interface with the local customer - DPRO - was part of the company's TQM initiatives. A stronger, pro-active relationship with

DPRO was required to identify and resolve concerns before they became serious. In 1989, the MDA reorganization included a stronger emphasis on Malcolm Baldrige concepts, with all company teams and processes examined for implementation of improved customer relationships.

MDA-West developed team concepts as part of these TQM initiatives. DPRO participation and membership were encouraged to ensure that customer expectations and concerns were considered. MDA-West responses to corrective action requests were coordinated with the DPRO to establish cooperative agreements. MDA-West's Quality Director began to meet with the DPRO Quality Representative to resolve issues and communicate activity interest. MDA-West's process-based management techniques were coordinated with the DPRO process specialist to monitor process improvement opportunities.

As a result of these improved customer relations, it was determined that MDA-West and DPRO had many common interests and goals. The benefits obtained from these improved customer relations included removed barriers between MDA-West and DPRO to allow for resolution of issues to the satisfaction of both parties. In addition, customer expectations were better understood and therefore more effectively satisfied. And finally, the establishment of numerous avenues of customer interface encouraged concerns to surface and be resolved.

### Civic and Community Affairs

MDA-West demonstrates its commitment to civic and community affairs through its employees who volunteer thousands of hours and substantial donations. These efforts are the responsibility of a small group of professionals, less than 30 people for the McDonnell Douglas Corporation worldwide.

The McDonnell Douglas Corporation uses a strategic plan that clearly outlines the focus of its commitment. The Plan begins with the recognition of three primary funding resources.

The McDonnell Douglas Foundation has assets of \$60.45 million to provide an annual contribution budget of \$8.3 million. The MDA charitable contributions are grants made directly by local McDonnell Douglas companies. The annual local budget for 1993 was \$250K.

Each Local Business Unit supports an Employee's Community Fund. These funds are made available by voluntary payroll deductions. In 1992, 67% of the corporate employees participated. The funds are contributed to local and regional community organizations. There is also a corporate Political Contribution Fund to support the campaigns of state and local political candidates and ballot issues, and a Gifts in Kind program that includes the donation of surplus property and the use of some corporate facilities and services to worthy causes.

---

A major source of community involvement is the Employee Volunteers Program which includes all levels of employees, including the executives. It is administered as part of each company's Community Help and Involvement Program. The activities undertaken at MDA-West by the Community Help and Involvement Program's organization and in cooperation with other corporations in the region have been favorably viewed by the community and local governmental bodies. One of these programs is the Homework Hot line in which volunteers man telephones to help children in the elementary through high school levels with math and science homework problems.

## **DATA REQUIREMENTS**

### **MDA-West/Customer Complaint Tracking System**

A joint DPRO/MDA-West team was developed to streamline the process of documenting verbal corrective action requests (CARs). Previously, CARs were documented in a

manual log and through written letters, and immediate visibility for these action requests was not apparent. The logging method also did not facilitate efficient trend analysis and general tracking.

A mainframe computer program was developed to track CAR information which was accessible to both DPRO and MDA personnel. MDA personnel were given read only access. Numerous help features were added to the program for easy use, and discrepancy codes were developed by DPRO to make overall analysis more efficient. The database's reporting capabilities include open CAR lists, real time CAR information, and real time CAR closure. Trend analysis can be performed in a variety of Pareto breakdowns.

As a result of this new tracking system, there is immediate access to data for faster resolution of complaints. The data can be used by both MDA-West and DPRO for analysis, and regular trend analysis has helped identify improvement opportunities. DPRO discrepancy codes have helped MDA-West better understand DPRO perceptions of problems and the processes to which they relate.

---

# SECTION 4

## INFORMATION

---

### 4.1 DESIGN

#### DESIGN POLICY

##### System Architecture

With the proliferation of information systems, communication between systems and sharing of information in many cases is problematic. Some years ago, MDA used isolated computers for their engineering design, analysis, and test functions, and manufacturing engineers had to rebuild models from hardcopy output created by the design team. MDA realized that change was needed.

Standard information systems application protocols were developed to ensure concurrency of data across the 100 minicomputer to mainframe computers currently in operation. Barriers between functional areas were broken down allowing engineers to work concurrently while sharing information seamlessly. In order to standardize data across various sites and functional areas, specific data elements were identified for each job function and used to build a common data dictionary. Unigraphics CAD was selected for all users to ensure that user's design, analysis, and manufacturing needs were supported. Redesign of the system included the use of standard inputs and outputs such as MIL-STD-28001, MIL-STD-28002, MIL-STD-28003, on CALS compliant 1840A transfer media.

The following benefits were realized by MDA by changing the previous system architecture:

- Concurrency of data across application systems;
- Reduced paper flow between groups;
- More intelligible information from systems;
- Integration of remote design and manufacturing centers;
- Use of system-supplied metrics to better manage people and data;
- Use of CALS/CITIS, thereby increasing customer satisfaction;
- Reduction of redundant data;
- Use of complete up-to-date information; and,
- Reduced cost and development time.

### 4.2 TEST

#### INTEGRATED TEST

##### Concurrent Design and Test

MDA-West has converged test development with concurrent engineering efforts. Test and verification personnel are an integral part of product development teams, and all tests conducted at MDA-West are a result of the work of concurrent engineering teams. Personnel from other functional areas are involved in the planning and design of tests. There are several examples and areas in this effort:

##### *The Thermal Shroud Project:*

The Thermal Shroud is a protective cover for the space station truss assembly. The project involved team members from design, test and verification, material and process, and others. Unlike past development projects, actual construction and test planning of the shroud was started prior to completion of its development. This resulted in the shroud being quickly completed. Using the concurrent engineering approach eliminated costly redesign efforts and improved the resulting product's quality.

##### *Design Of Experiments:*

MDA-West began implementing Design of Experiments (DOE) in its testing projects and maintains that cost savings can be realized from conducting DOE. The Test and Verification group has identified an internal expert for facilitating the use of DOE in testing projects. The method is currently being used in the pyroshock area for gaining a better understanding of pyrotechnic shock phenomena. A DOE 3<sup>2</sup> factorial matrix was used for one set of tests to measure the effects, interaction, and relationship of position to amount of explosive. The results of this test demonstrated the effectiveness of DOE as a quick means of obtaining needed information with a minimum number of tests.

##### *Rip-Stitch:*

Another innovative adoption by the Test and Verification group is used during the demonstration of fairing separation.

Fairings enclose the various sections of a rocket and must be separated when the rocket changes from one booster stage to another. McDonnell Douglas uses an explosive bolt technique. During the demonstration test, the fairing sections must be restrained during the explosion of the connecting bolts. This is accomplished by the use of Rip Stitch Energy Absorbing Chords. Such straps have been used for some time by mountain climbers to control falls. The strap is doubled and stitched together. If a climber should fall, the force of the fall starts to pull the two sections of the strap apart, and the stitching tears. As the stitches tear, they absorb energy and evenly decelerate the falling climber and stop the fall. This same technique is applied to decelerate and contain the falling sections of the rocket fairing.

## LIFE

### Solution Process Control and Salt Spray Testing

MDA had been experiencing an increasing number of failures from Salt Spray testing. Such testing is required by MIL-A-8625 and MIL-C-5541 for reliability and durability of military equipment. However, the existing test chamber could not maintain process tank control and salt-spray testing within the specified limits. Pitting exceeded 15 pits per 150 square inches. In looking at various process options, MDA learned that this was a problem throughout the industry. Therefore in 1990, MDA entered into agreement with the Engelhardt company to build a more effective salt spray testing chamber.

To MDA specifications, the Engelhardt chamber has been designed to comply with test requirements according to ASTM-B117 and now dispenses a more uniform spray. The salt mixture is at 0.3% total impurities with just a trace of nickel and copper. The salt solution is compliant with  $5 \pm 1\%$  sodium chloride by weight, specific gravity of 1.0268 to 1.0413, approximately 95 degrees F, and 200 parts per million soluble solids, and a pH factor of 6.5 to 7.2.

Within six months, improvements in test reliability improved significantly, and there has been enhanced consistency of the test parameters.

## 4.3 PRODUCTION

### QUALIFY MANUFACTURING PROCESS

#### Development of Fiber Optic Manufacturing Capabilities

MDA has developed methods of manufacturing and characterizing space qualified fiber optic bundles. To achieve

preferred supplier status at competitive cost levels, MDA applied an innovative management and manufacturing control approach including product performance verification and personnel training.

The Space Station Freedom program has placed unique requirements (space environment considerations) on fiber optic cables which has necessitated MDA to develop a manufacturing method for preparing cable ends, installing and mounting connectors, and characterizing cable performance. To enhance its capabilities to the customer, MDA applied principles of conscientiously providing superior products, quick response to design changes, flexibility in termination systems and innovative manufacturing processes and organizational structure. The organizational operating framework employed TQM and continuous improvement techniques. The limited budget was maximized by striving for first time quality through a focused development team, worker involvement with process development, and emphasized controls and skills development.

To characterize cable performance, MDA has established a test equipment calibration method and standard cable performance test to create a database enabling SPC methods to be applied to the cable manufacturing process. Capabilities including temperature cycles and shock, thermal vacuum, and vibration analysis are available. Connector systems have been characterized to remove this bias from cable performance evaluation. A portable cable termination and test system has been developed with diagnostic and troubleshooting capabilities.

MDA has developed the supplier base, skilled personnel, manufacturing process flows and testing techniques needed for the manufacture of space qualified fiber optic cables.

## PIECE PART CONTROL

### SPC Applications in Assembly Hole Drilling

Prior to 1989, MDA was experiencing problems and subsequent rework of various fastener holes in assemblies in the commercial and Titan IV missile applications. To determine where the problem was occurring and ascertain the root cause of the problem, MDA instituted an SPC procedure.

The initial investigation by quality engineers revealed that improper hole preparation by the personnel appeared to be the cause of the problem. Consequently, a training plan was developed and all personnel involved in hole drilling and preparation were given 24-40 hours of training in SPC processes. The strategy employed was to define and standardize the hole drilling process, conduct a measurement system analysis, establish a data collection system, and ultimately achieve process control.

Personnel involved in the process soon discovered that each had a different method and technique for drilling and inspecting the holes. Data was collected that revealed the variability of the process. When the employees saw this variability, they developed a standardized drilling process that reduced some of the variability due to operator technique. The next step was to purchase a data collection system that was easy to use on the shop floor and would automatically record and display various statistical charts to the personnel. MDA purchased a Genesis QA 3000 computer manufactured by Quality Measurement Systems. The measurement device was also changed from a Mahr hole gage to an electronic digital indicator, a remote transducer and Dimetron Plug Gages that could be coupled to the Genesis system. Data gathered from the use of these systems revealed further variability in the hole sizes. Corrective action was taken to standardize the drilling tools and equipment. This standardization further reduced variability.

The benefits derived from this SPC approach have helped MDA to baseline, improve, and standardize hole drilling procedures. It has developed and implemented tool kits for the shop floor, baselined and standardized gaging processes, and developed and implemented SPC data collection systems. The net result of this effort was a 42% reduction of hole drilling non-conformances in aircraft and a 65% reduction of hole drilling non-conformance in Titan IV.

## **TOOL PLANNING**

### **Tool Management System**

Conventional NC or CNC machining requires a programmer to determine the number of cutters and the necessary cutter geometry to produce the desired part. The cutter path is then defined by the programmer. The follow-on step requires a tool presetter (usually a tool crib attendant) to preset the tooling into the tool holders at given and accurate set lengths from the tool tip to the spindle face. NC/CNC machines have cutter compensation built into the control systems and frequent operator errors can occur in determining cutter compensation, only new full size cutters are used in the machining operations. The process of presetting tooling is expensive and time consuming.

MDA overcame this obstacle through the use of an innovative tool management program that utilizes a non-contact read/write computer chip known as a tag. This tag is combined with an optical tool presetter and an interactive tool tag read/write head on the machine. The inexpensive tag is attached to the tool holder. The presetter is electronically linked with MDA Tooling Databases and transmits

relevant data to the tag. Data encoded on the tool tag is tool identification number, tool serial number, measurement (inches/metric), tool nominal length, actual tool length, actual-nominal offset value, tool nominal diameter, actual tool diameter, actual-nominal offset value, nominal tool life time, and actual tool life time.

The cutting tools are now randomly loaded into the machine where the tool tag is read before the tool is placed into the spindle, then read and verified before the actual programmed cutting time is written to the tag. The interactive machine controller and tool tag read/write head software automatically adjusts the NC program for tool length and diameter compensation and tool holder location in the tool magazine. This effort ensures the proper tool is always in the spindle, cutter life cut times are monitored for maximum tool life, and actual average cutter life times can be determined.

Benefits of this tool management system include reduction of cutting tool procurement as cutters are used until life expires; full utilization of existing cutter inventory through grinding and reconditioning of existing cutters; elimination of errors at the machine tool as tools cannot be misidentified; and transparent compensations to the machine operator. Additionally, reductions of up to 50% could be experienced in tool presetting times.

### **Tool Tracking**

MDA-West provides careful and precise tracking of thousands of specialized tools in a conscientious and timely manner. MDA-West has a system of control that uses bar codes on many items, and is easily accessed for quality audits. This helps the company maintain control over a large number of specialized tools that vary in size from a matchbox to an entire building. Using this technique, the tools cannot be lost and MDA avoids major delays and funds expenditure. The evolution of the company's Operations Business Management System should even further improve the real-time tracking of these unique and therefore controlled tools.

## **COMPUTER-AIDED MANUFACTURING**

### **Tube Center**

In 1988, MDA's tube shop was primarily used to provide tubes for the Delta II program. At that time, manual tube bending machines and bend radius templates (BRTs) were used to perform this function. Since that time, due to changes in the work required by new customers, the shop has made some significant changes. An automated tube

---

preparation center has been developed using state-of-the-art technology.

The basis of the system is a laser-operated, in-line tube inspection center manufactured by Eaton Leonard. This machine is linked to the engineering database allowing the design engineer to download tube geometry data directly to the NC tube bender which forms the tube to the required shape. This design is then stored in the database for future application. The system has the capability to provide quick response to new designs and has eliminated the need for using BRTs. The laser operated inspection center is used not only to inspect finished tubes, but also to reverse engineer tube bend information from existing BRTs formerly used.

In addition to the inspection center and NC bender, the center also has the necessary equipment to apply end fittings on the finished formed tubes. A computerized tube label printing machine is used to produce the necessary labels required on all finished tubes.

Since incorporating these changes, the cycle times and production rates have improved significantly while at the same time reducing the number of rejects and/or rework. Future plans include the addition of equipment to support tubing up to three inches in diameter.

## **ENVIRONMENTAL ISSUES**

### **Environmental Improvement Program**

Before 1990, McDonnell Douglas Aerospace did not have a strategic Occupational Safety, Health, and Environmental (OSHE) Plan. The company was operated using internal procedures and a safety manual. In 1989, A.D. Little performed a OSHE Management Assessment and identified a need for a formal process to define and manage environmental risks and a need for management to develop a clear policy for environmental guidance.

McDonnell Douglas Corporation developed a criteria for evaluating risks and included risk categories of Health and Safety, Environmental, Regulatory Compliance, Operational Concerns, Liability, and Reputation. These categories include different levels of risk. To evaluate these risks, topics or issues are listed with fact sheets for each issue. A risk matrix, containing the likelihood and magnitude of risks, is prepared for each issue and the matrix is evaluated. A technology team works on process changes to reduce risks.

The program has top management support which is necessary for achieving compliance. Some specific issues which require action are air emissions, including toxics and ozone depleters, and waste minimization. Some of the

successful projects in reducing air emissions include water soluble lubricants, the replacement of methyl chlorides for paint stripping and clean-up, new efficient vapor degreasers, and the replacement of Freon 113 with Citro-Kleen, a terpene-based cleaner. To reduce hazardous wastes, in-plant uses were found for out-of-date chemicals. Hazardous materials no longer needed were returned to the supplier, donated to universities, or sent to a recycler.

MDA recognized the need for a definitive environmental policy and created a policy that clearly directs its activities in environmental areas. It identified and assessed the risks, including their magnitude and likelihood. This policy enabled MDA to move decisively in removing those risks. This policy allows it to meet the environmental requirements today and well into the future.

## **4.4 FACILITIES**

### **FACTORY IMPROVEMENTS**

#### **Operations Business Management System Integrated Production Engineering Management Systems**

MDA-West is installing a new MRP II system called The Operations Business Management System II (OBMS). OBMS is a singular, computer-based system designed to replace 12 independent/interdependent operating systems that currently support purchasing, inventory, material planning and release, order status and location, labor hours collection, material non-conformance, shop floor performance, and capacity planning.

The OBMS total system solution provides the functionality for the planning, execution, and control necessary to carry out the production and manufacturing effort. In selecting a supplier for the software of the OBMS, MDA-West developed a systems requirements questionnaire that contained 1,300 questions. The prospective suppliers scored themselves for capability to comply to each of the requirements using a graded scale. The supplier scores were evaluated and site visits to other companies using the prospective supplier product were conducted. A supplier was selected and an unlimited site license agreement was negotiated, after the necessary internal approvals were obtained based on return on investment studies.

The team developed "as-is" and "to-be" process flows. Redundancy and non-value added tasks were identified in the "as-is" processes. The "to-be" processes showed the elimination of such tasks that led to both business and cultural updates. As a result, the expected annual savings by

implementing OBMS include a 30% reduction in inventory carrying costs, a 20% reduction in touch labor, and a 20% reduction in support labor.

MDA-West is also installing another computer-based system that will be linked to OBMS, the Integrated Production Engineering Management Systems (IPEMS). As with OBMS, IPEMS is an automated system designed to replace existing systems used to generate production engineering documentation such as fabrication and assembly process plans and time standards. The expected benefits of IPEMS are reduced planning throughput time by 50%, decreased paper handling costs by 80% and improved quality of released data by 60%. This type of a system, in generic form, is commonly referred to in the industry as Computer Assisted Assembly Planning and Computer Assisted Process Planning.

## **4.5 LOGISTICS**

### **SPARES**

#### **Sale of Spares**

The sale of spares to users of MDA products is an important and integral part of the company's success in maintaining a satisfied customer base. MDA-West has instituted a fair and equitable policy for spares and their sale to the government. The policy provides that the company will:

- Provide spares for all users of their products;
- Promote the government's position on fair and economical process;
- Always recommend purchase from the true manufacturer of the part (even if not MDA);
- Advise customers when prices are affected by minimum quantities, tooling and set-up changes, etc.;
- Voluntarily make price adjustments or refunds to correct errors; and,
- Voluntarily supply a refund when a customer is dissatisfied with the price of a spare.

Through clearly stated and ethical policies and practices, MDA-West has been successful at providing spares and recovering a fair return on investment at the same time. Another key factor in the MDA-West approach to the spares sale has been the designation of a single point of contact within the company to contract and coordinate the production and delivery of spares.

The system that will aid the company in providing this service in a more effective and efficient manner will be the incorporation of the spares data needs into the OBMS.

## **4.6 MANAGEMENT**

### **MANUFACTURING STRATEGY**

#### **Strategic Quality Planning**

MDA-West's Strategic Quality Plan (SQP) resulted from a self assessment in 1990 using the Malcolm Baldrige Award criteria. At that time, quality and business plans were separate and "quality" was viewed as a discrete discipline. In order to meet the company's objective of becoming the preferred supplier in its key market segments and to become a company which embodies TQM, it was determined that a Strategic Quality Planning thrust was needed.

A team was established to study the quality management and planning processes of best-in-class companies such as Xerox, Westinghouse, Federal Express, and Motorola. The team determined that these companies had five quality management characteristics in common:

- Quality driven leadership;
- Quality driven learning, development, and personal mastery
- Quality driven teams and partnerships
- Quality driven continuous improvement; and,
- Quality driven supportive environment.

These five characteristics became the Five Imperatives of the MDA Strategic Quality Plan supported by 22 Quality Initiatives. Consensus was achieved on the imperatives and initiatives, and accountability for approach, deployment, and results was established. The Enterprise Strategic Quality Plan was distributed to all management and deployed through unit and Horizontal Team quality plans. Progress is reported quarterly by each division and horizontal team to the Executive Council. An annual assessment is performed on the plan against strategic business objectives and to measure progress. An annual self assessment measures progress using the Baldrige criteria.

The Strategic Quality Planning process provided valuable lessons learned. The SQP must be deployed to all levels of management. Plans should be both visionary and specific and should focus on customer satisfaction (both internal and external). The approach to Strategic Quality Planning must have ample data and analysis incorporating

customer requirements, strategic business objectives, market analysis, customer strategic plans, competitor assessments, and division business plans. Quality planning must clearly link to strategic and operating planning processes. Figure 4-1 depicts the MDA Enterprise Quality Planning Process.

The Quality Planning Process provided MDA a common focus that improved the linkage, communication, and clarification of the company's quality initiatives. It provides the focus needed to meet customer requirements as well as internal business and performance goals. The process clearly defines accountability for approach, deployment, and results.

### Strategic Business Objectives

Strategic Business Objectives (SBOs) are specific, measurable goals that are participatively developed at all levels of the enterprise or company. Companies develop strategic plans with annual five-year goals. Goals must typically be specific, quantifiable, challenging but "do-able," and tied directly to a reward system. In addition, a method must be established to communicate each level's goals to the next level down (flowdown) and also send feedback (roll-up) to

the next level up. The MDA-West approach uses its vision statement to define the direction for the organization. The vision goal states:

"We are recognized by our customers, employees, supplier, and competitors as the world's preeminent space systems company. We do things right the first time while continuously striving for improvement..."

To establish SBOs at the enterprise (company) level, the objectives were set in the areas of customer, culture, and financial. At that level, the SBOs were:

- To become the preferred supplier in the company's key market segment;
- To be a company that is the embodiment of TQM; and
- By the year 2000, achieve annual sales of \$[X] billion, return on sales of [Y]%, and return on investment of M[Z]%.

The company empowered an executive council (EXCON) to administer the company in terms of ensuring its goals and roles were aligned at all levels of the company, and translated into meaningful, workable, and easily understandable (specific) sub-goals.

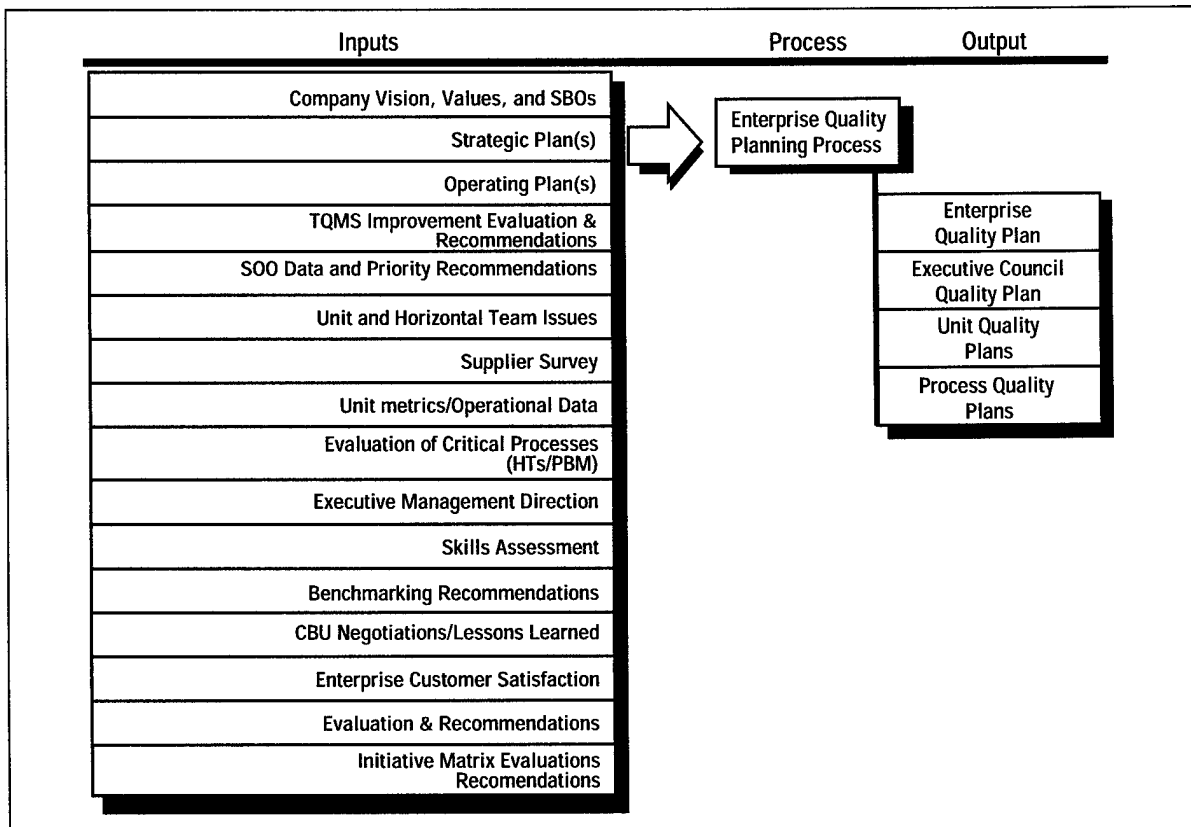

FIGURE 4-1. ENTERPRISE QUALITY PLANNING PROCESS

This flowdown is illustrated in Figure 4-2 which shows that each level of the company established objectives that must be signed off by the leader of the next higher level in the company to ensure alignment of the objectives with that higher level's objectives. When the entire process is complete, all personnel are synchronized. The purpose of this important exercise was to involve everyone in the process of goal setting and thus create a better operational roadmap from the flowing down of the objectives throughout the organization down to setting goals at the individual level.

While every company has its own method for communicating its goals to its employees, the magnitude of personnel involvement at all levels of the company at MDA-West led to major cultural changes. This effort is evidenced by the company's continued growth over the last few years in the face of a decidedly down-turned market.

The benefits of this approach to setting objectives is that all employees see themselves as setting common objectives

and therefore living with a common fate. The process inherently leads to better communications in the company so all employees understand priorities. It is performed in such a way that alignment of the company is assured. The process ensures management accountability and provides a positive team building experience for company personnel.

## DATA REQUIREMENTS

### CALS

CALS is anticipated to be an important tool developed by and through a government and industry partnership. CALS is a Department of Defense and industry strategy to enable and accelerate the integration of digital information for weapon system acquisition, design, manufacture and support. It will, when fully implemented, provide an effective transition from the current paper-intensive weapon system

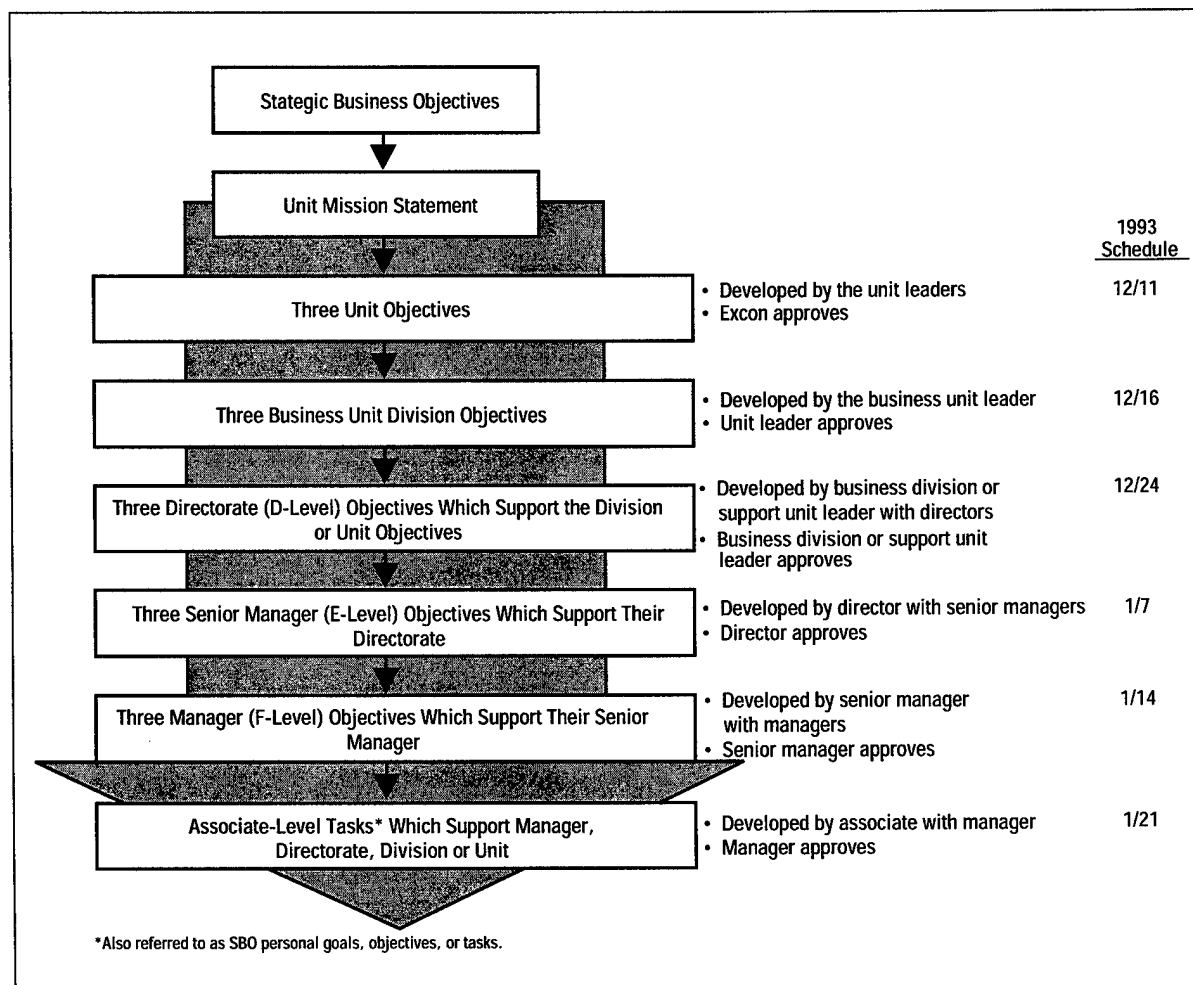

FIGURE 4-2. STRATEGIC BUSINESS OBJECTIVE FLOWDOWN

support process to the efficient use of digital information technology.

MDA-West is fully developing understanding the myriad of uses possible once CALS is implemented nationwide. The key to using CALS is the development of a Contractor Integrated Technical Information System (CITIS) that will provide the government with access to program (such as business and technical) data and applications associated with system acquisition. CITIS will also allow program managers to work together without collocation. This concept will be a cultural change, but one that can affect program efficiency and overall effectiveness in the weapons design, building, and procurement areas.

MDA-West clearly sees the importance of CALS and has progressed in a strong but measured way to use CALS as effectively as possible under the budget constraints of the present business climate. It will be in the forefront of developing the capability to exchange data (text and graphics) with other companies in real time and in a secure manner. This will allow MDA and other industry components to produce goods and products of high quality and in a more efficient manner.

### MDA-West/Non-conformance Database

Prior to 1986, MDA-West manually logged MRB non-conformances which limited overall trend analysis capability. It was concluded by MDA-West management that this was inadequate as overall MIL-STD-1520 requirements were not being adhered to since multiple rejections were not tracked and defect/part history was not being maintained. MDA-West was also unable to track non-conformances through the MRB cycle for real time information.

MDA-West created a Non-compliance Database with DPRO involvement. A team was formed to review rejection documents and identify system requirements. Information was entered into this database on a mirror image of a rejection form to allow for an easy understanding for the non-conforming information, as presented. The database process is illustrated in Figure 4-3.

Developing this non-conformance database has provided MDA-West with an increased visibility to multiple rejections; a reduction in MRB cycle time; more effective trending capabilities through improved defect codes; elec-

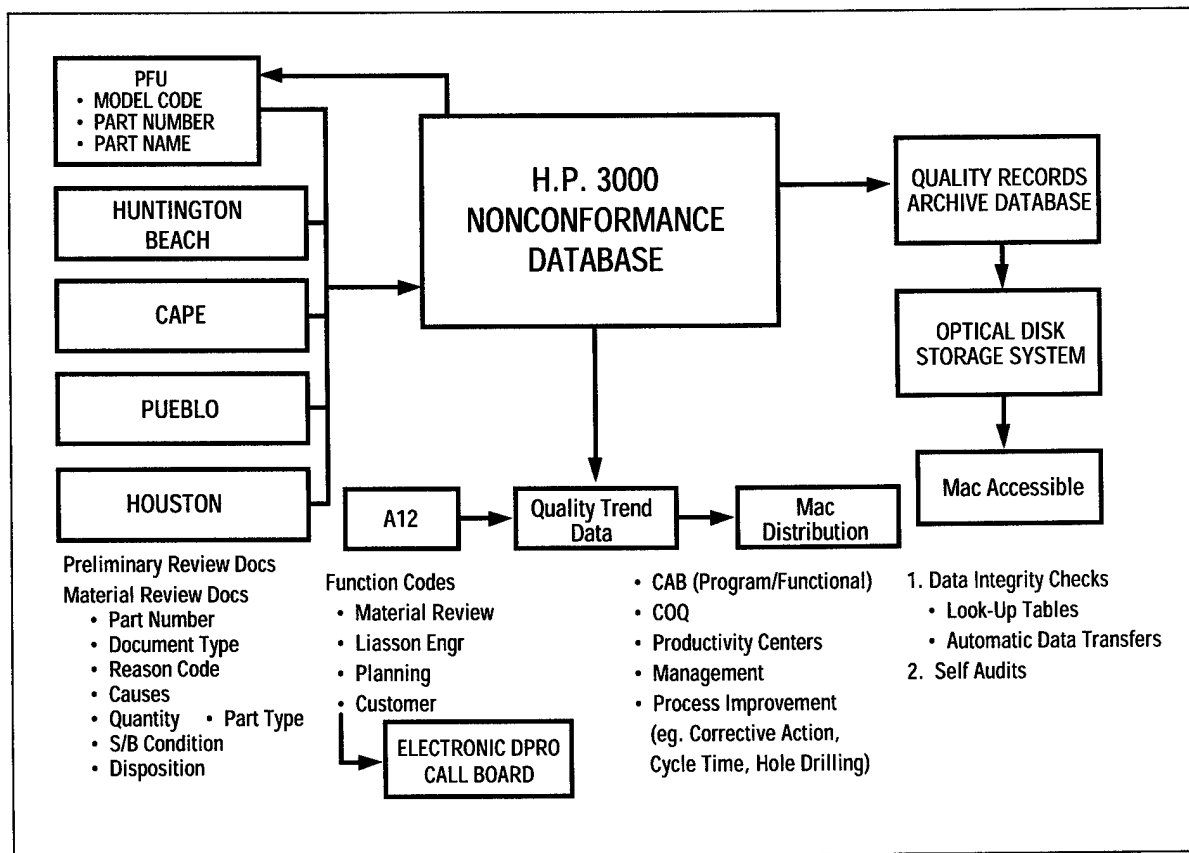

FIGURE 4-3. NON-CONFORMANCE DATABASE

---

tronic call boards to the customer; status capability from rejection through acceptance; and automated charting.

## QUALITY ASSURANCE

### Enterprise Quality Council

Until recently there was no single entity at MDA-West that focused on quality and the quality planning process. Quality related activities were conducted by a variety of councils, committees, and organizations. A 1990 self-evaluation identified areas where improvement was needed. No clear approach existed for communicating quality values daily in the workplace. Deployment of quality values was just beginning. Quality goals had not been quantified, and management had not established a clear leadership role for implementing TQM. Training and the use of quality problem solving techniques were not applied at all levels of the company.

The Executive Council chartered a sub-team composed of the TQMS-IE management team, the Horizontal Team leaders, and other selected individuals. This team studied the quality management and planning processes of best-in-class companies such as Xerox, Motorola, GE, and Westinghouse. The sub-team recommended establishing a company quality council to develop a management strategy for TQM implementation including defining the company's quality journey and monitoring progress toward achieving quality objectives. The Company Quality Council (CQC) was established in 1991.

The CQC reported to the Executive Council. It was chaired by the Vice-President and General Manager of the Quality Systems Division. Membership included more than 30 division representatives, Horizontal Team leaders, and representatives from TQM Planning and Communications. The CQC provided a single focus for quality throughout the enterprise. A Quality Plan was developed, approved, and flowed down to all units and a matrix was developed to measure progress. Other activities of the CQC included deploying quality policy throughout the organization, reviewing quality training, establishing a common continuous improvement approach, and managing benchmarking for the enterprise.

By the end of 1992 it became apparent that although the CQC successfully coordinated activities and projects across the company and provided a useful and important service to the

company, its membership was too large. Meetings were not always productive, and the council could not act in a timely manner. In January of 1993, the council was restructured as a smaller group with increased representation from programs and renamed the Enterprise Quality Council. This new team moved quickly to develop and publish MDA Quality Policy and Values, evaluate the current state and approach against the Baldrige criteria, develop a draft enterprise metrics architecture, and conduct 1993 Baldrige criteria training. Current Actions in progress include developing an MDA training approach and architecture, integrating the Quality Planning process, and reviewing supplemental SOO questions.

### Quality Assessment

MDA-West has established a Mission Statement for its quality assessment process that ensures that this service is focused on improving the quality of processes and operational systems' consistency and performance across all products, services, functions, and locations of the MDA-West business units. Quality Assessment goes beyond a normal quality audit in helping the organizations to address the problems that were determined during the audit. Most audits focused on compliance (not effectiveness), were not jointly reviewed by multiple levels of management to provide for non-recurrence, and the timeliness of the results was poor at best.

The method of operation of QA is similar to most large companies but the use of a computerized Assessment Results Tracking Systems (ARTS) allows all levels of the company to review and exercise QA tools toward their particular organizations' benefits. ARTS is used to ensure assessment results are monitored; dates are collected and displayed on the timeliness of responses; aggregate findings data is provided to Process, Horizontal Teams and Business/Support units; and Monthly Enterprise (company level) status reports are tailored to the preferences of management.

The results of the MDA-West QA procedures have provided management with a pro-active system for better planning and process improvement. There is 100% implementation of recommended resolutions and much improved response times. In 1992, 74.1% of responses were on time, average delay of other responses was 11.5 days. The QA system demonstrated savings and avoidance costs (in 1992) of over \$3.6 million and due to its effective implementation, resulted in external oversight being reduced.

# SECTION 5

## **PROBLEM AREAS**

---

### **5.1 FUNDING**

#### **MONEY PHASING**

##### **Lack of Adequate Research, Development, Test, and Evaluation Funding for Concurrent Engineering**

The current funding allocations for various phases of life cycle acquisition do not adequately support the product concept and development stages in a concurrent engineering environment. These concepts, when appropriately applied, are recognized throughout industry as a means to improve product quality, to shorten delivery cycle times, and to reduce customer cost.

Concurrent engineering is a systematic approach for considering all downstream process activities during the early design stages. As the development migrates through early systems engineering functional block diagrams, system allocations and system partitioning, the downstream details evolve. However, concurrent engineering is a sequential *and* parallel activity process. To maximize concurrent engineering benefits, later phases must be addressed earlier.

Project resources must be funded earlier than when they currently are in the product and development stages. The lines between each milestone in the acquisition cycle are not discrete for technical development efforts because of timed

parallel activities. The inertia of slowing or stopping an effort is disruptive and costly. As demands continue to shorter cycle times, the disparity between technical development and funding allocations will increase.

To remain globally competitive, the funding profile must support the development process. The Defense System Acquisition Management Process funding allocations should be analyzed and appropriately modified to maximize concurrent engineering concept benefits. A funding profile that allows effective resource allocations for concurrent engineering must be developed.

### **5.2 PRODUCTION**

#### **ENVIRONMENTAL ISSUES**

##### **Composite Disposal**

McDonnell Douglas maintains capabilities for manufacturing items made from graphite-epoxy pre-preg composite materials. It has been seen that scrap and surplus material is being disposed of by discarding the material and subsequently sending it to landfills. New material averages \$40-\$50 per pound, and there is an industry-wide problem with this material because there is no known way of re-using the material or recycling it. It is suggested that an economical process be developed to reuse or recycle the material.

# APPENDIX A

## **TABLE OF ACRONYMS**

---

### **ACRONYM DEFINITION**

ACT	Advanced Composite Technology
ATP	Advanced Technology Program
ARTS	Assessment Results Tracking Systems
BRT	Bend Radius Template
CALS	Computer-Aided Acquisition and Logistics Support
CalSIP	California Supplier Improvement Program
CAR	Corrective Action Request
CE	Concurrent Engineering
CITIS	Contractor Integrated Technical Information Services
CQC	Company Quality Council
DC-X	Delta Clipper Experimental Vehicle
DOE	Design of Experiments
ECC	Electronic Change Control
FIT	Factory Improvement Team
GRIP	Graphic Interactive Programming
GTA	Gas Tungsten Arc
IPD	Integrated Product Development
IPEMS	Integrated Production Engineering Management Systems
MDA	McDonnell Douglas Aerospace
OBMS	Operations Business Management System
OSHE	Occupational Safety, Health, and Environment
RAPIDS	Rapid Prototyping and Integrated Design System
SBO	Strategic Business Objective
SLA	Stereolithography
SOO	Survey of Organization
SQP	Strategic Quality Plan
SSRT	Single Stage Rocket Technology
TQMS-IE	Total Quality Management System - Improvement Evaluation
VPPA	Variable Polarity Plasma Arc

# APPENDIX B

## ***BMP SURVEY TEAM***

---

<b>NAME</b>	<b>ACTIVITY</b>	<b>FUNCTION</b>
<b>Larry Robertson</b> (812) 854-5336	<b>Crane Division</b> Naval Surface Warfare Center Crane, IN	<b>Team Chairman</b>
<b>Amy Scanlan</b> (206) 679-9008	<b>BMP Representative</b> Oak Harbor, WA	<b>Technical Writer</b>
<b>TEAM A</b>		
<b>Don Hill</b> (317) 353-7221	<b>Naval Air Warfare Center</b> Aircraft Division-Indianapolis Indianapolis, IN	<b>Team Leader</b>
<b>Steve Ratz</b> (317) 353-7151	<b>Naval Air Warfare Center</b> Aircraft Division-Indianapolis Indianapolis, IN	<b>Team Leader</b>
<b>Jerry Hudson</b> (814) 269-2804	<b>National Defense Center for Environmental Excellence</b> Johnstown, PA	
<b>TEAM B</b>		
<b>Richard Purcell</b> (703) 271-0366	<b>BMP Representative</b> Washington, DC	<b>Team Leader</b>
<b>Larry Halbig</b> (317) 353-3838	<b>Naval Air Warfare Center</b> Aircraft Division-Indianapolis Indianapolis, IN	

---

# APPENDIX C

## NAVY CENTERS OF EXCELLENCE

---

### **Automated Manufacturing Research Facility** (301) 975-3414

The Automated Manufacturing Research Facility (AMRF) – a National Center of Excellence – is a research test bed at the National Institute of Standards and Technology located in Gaithersburg, Maryland. The AMRF produces technical results and transfers them to the Navy and industry to solve problems of automated manufacturing. The AMRF supports the technical work required for developing industry standards for automated manufacturing. It is a common ground where industry, academia, and government work together to address pressing national needs for increased quality, greater flexibility, reduced costs, and shorter manufacturing cycle times. These needs drive the adoption of new computer-integrated manufacturing technology in both civilian and defense sectors. The AMRF is meeting the challenge of integrating these technologies into practical, working manufacturing systems.

### **Electronics Manufacturing Productivity Facility** (317) 226-5607

Located in Indianapolis, Indiana, the Electronics Manufacturing Productivity Facility (EMPF) is a National Center of Excellence established to advance state-of-the-art electronics and to increase productivity in electronics manufacturing. The EMPF works with industry, academia, and government to identify, develop, transfer, and implement innovative electronics manufacturing technologies, processes, and practices. The EMPF conducts applied research, development, and proof-of-concept electronics manufacturing and design technologies, processes, and practices. It also seeks to improve education and training curricula, instruction, and necessary delivery methods. In addition, the EMPF is striving to identify, implement, and promote new electronics manufacturing technologies, processes, materials, and practices that will eliminate or reduce damage to the environment.

### **National Center for Excellence in Metalworking Technology** (814) 269-2420

The National Center for Excellence in Metalworking Technology (NCEMT) is located in Johnstown, Pennsylvania and is operated by Concurrent Technologies Corporation (CTC), a subsidiary of the University of Pittsburgh Trust. In support of the NCEMT mission, CTC's primary focus includes working with government and industry to develop improved manufacturing technologies including advanced methods, materials, and processes, and transferring those technologies into industrial applications. CTC maintains capabilities in discrete part design, computerized process analysis and modeling, environmentally compliant manufacturing processes, and the application of advanced information science technologies to product and process integration.

### **Center of Excellence for Composites Manufacturing Technology** (414) 947-8900

The Center of Excellence for Composites Manufacturing Technology (CECMT), a national resource, is located in Kenosha, Wisconsin. Established as a cooperative effort between government and industry to develop and disseminate this technology, CECMT ensures that robust processes and products using new composites are available to manufacturers. CECMT is operated by the Great Lakes Composites Consortium. It represents a collaborative approach to provide effective advanced composites technology that can be introduced into industrial processes in a timely manner. Fostering manufacturing capabilities for composites manufacturing will enable the U.S. to achieve worldwide prominence in this critical technology.

# APPENDIX D

## PROGRAM MANAGER'S WORKSTATION

---

The Program Manager's Workstation (PMWS) is a series of expert systems that provides the user with knowledge, insight, and experience on how to manage a program, address technical risk management, and find solutions that industry leaders are using to reduce technical risk and improve quality and productivity. This system is divided into four main components; KNOW-HOW, Technical Risk Identification and Mitigation System (TRIMS), BMP Database, and Best Manufacturing Practices Network (BMPNET).

- **KNOW-HOW** is an intelligent, automated method that turns "Handbooks" into expert systems, or digitized text. It provides rapid access to information in existing handbooks including Acquisition Streamlining, Non-Development Items, Value Engineering, NAVSO P-6071 (Best Practices Manual), MIL-STD-2167/2768, SecNav 5000.2A and the DoD 5000 series documents.
- **TRIMS** is based on DoD 4245.7-M (the transition templates), NAVSO P-6071 and DoD 5000 event oriented acquisition. It identifies and ranks the high risk areas in a program. TRIMS conducts a full range of risk assessments throughout the acquisition process so corrective action can be initiated before risks develop into problems. It also tracks key project documentation from concept through production including goals, responsible personnel, and next action dates for future activities in the development and acquisition process.
- The **BMP DATABASE** draws information from industry, government, and the academic communities to include documented and proven best practices in design, test, production, facilities, management, and

logistics. Each practice in the database has been observed and verified by a team of experienced government engineers. All information gathered from BMP surveys is included in the BMP DATABASE, including this survey report.

- **BMPNET** provides communication between all PMWS users. Features include downloading of all programs, E-mail, file transfer, help "lines", Special Interest Groups (SIGs), electronic conference rooms and much more. Through BMPNET, IBM or compatible PC's and Macintosh computers can run all PMWS programs.

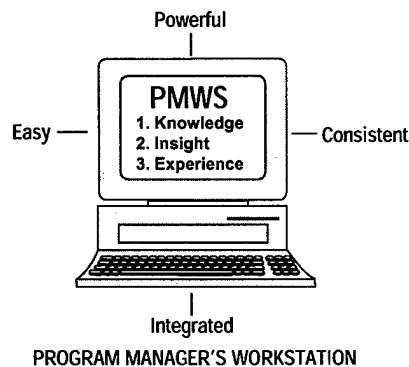

- To access **BMPNET** efficiently, users need a special modem program. This program can be obtained by calling the BMPNET using a VT-100/200 terminal emulator set to 8,N,1. Dial (703) 538-7697 for 2400 baud modems and (703) 538-7267 for 9600 baud and

14.4 kb. When asked for a user profile, type: DOWNPC or DOWNMAC <return> as appropriate. This will automatically start the Download of our special modem program. You can then call back using this program and access all BMPNET functions. The General User account is:

USER PROFILE: BMPNET

USER I.D.: BMP

Password: BMPNET

If you desire your own personal account (so that you may receive E-Mail), just E-Mail a request to either Ernie Renner (BMP Director) or Brian Willoughby (CSC Program Manager). If you encounter problems please call (703) 538-7799.

# APPENDIX E

## **NEW BEST MANUFACTURING PRACTICES PROGRAM TEMPLATES**

---

Since 1985, the BMP Program has applied the templates philosophy with well-documented benefits. Aside from the value of the templates, the templates methodology has proven successful in presenting and organizing technical information. Therefore, the BMP program is continuing this existing "knowledge" base by developing 17 new templates that complement the existing DoD 4245.7-M or Transition from Design to Production templates.

The development of these new templates was based in part on Defense Science Board studies that have identified new technologies and processes that have proven successful in the last few years. Increased benefits could be realized if these activities were made subsets of the existing, compatible templates.

Also, the BMP Survey teams have become experienced in classifying Best Practices and in technology transfer.

The Survey team members, experts in each of their individual fields, determined that data collected, while related to one or more template areas, was not entirely applicable. Therefore, if additional categories were available for Best Practices "mapping," technology transfer would be enhanced.

Finally, users of the Technical Risk Identification and Mitigation System (TRIMS) found that the program performed extremely well in tracking most key program documentation. However, additional categories – or templates – would allow the system to track all key documentation.

Based on the above identified areas, a core group of activities was identified and added to the "templates baseline." In addition, TRIMS was modified to allow individual users to add an unlimited number of user-specific categories, templates, and knowledge-based questions.

---

# APPENDIX F

## **PREVIOUSLY COMPLETED SURVEYS**

---

BMP surveys have been conducted at the companies listed below. Copies of older survey reports may be obtained through DTIC or by accessing the BMPNET. Requests for copies of recent survey reports or inquiries regarding the BMPNET may be directed to:

Best Manufacturing Practices Program  
2101 Crystal Plaza Arcade  
Suite 271  
Arlington, VA 22217-5660  
Attn: Mr. Ernie Renner, Director  
Telephone: (703) 696-8483  
FAX: (703) 271-9059

### **COMPANIES SURVEYED**

Litton  
Guidance & Control Systems Division  
Woodland Hills, CA  
October 1985 and February 1991

Texas Instruments  
Defense Systems & Electronics Group  
Lewisville, TX  
May 1986 and November 1991

Harris Corporation  
Government Support Systems Division  
Syosset, NY  
September 1986

Control Data Corporation  
Government Systems Division  
(Computing Devices International)  
Minneapolis, MN  
December 1986 and October 1992

ITT  
Avionics Division  
Clifton, NJ  
September 1987

UNISYS  
Computer Systems Division  
(Paramax)  
St. Paul, MN  
November 1987

Honeywell, Incorporated  
Undersea Systems Division  
(Alliant Tech Systems, Inc.)  
Hopkins, MN  
January 1986

General Dynamics  
Pomona Division  
Pomona, CA  
August 1986

IBM Corporation  
Federal Systems Division  
Owego, NY  
October 1986

Hughes Aircraft Company  
Radar Systems Group  
Los Angeles, CA  
January 1987

Rockwell International Corporation  
Collins Defense Communications  
Cedar Rapids, IA  
October 1987

Motorola  
Government Electronics Group  
Scottsdale, AZ  
March 1988

---

General Dynamics  
Fort Worth Division  
Fort Worth, TX  
May 1988

Hughes Aircraft Company  
Missile Systems Group  
Tucson, AZ  
August 1988

Litton  
Data Systems Division  
Van Nuys, CA  
October 1988

McDonnell-Douglas Corporation  
McDonnell Aircraft Company  
St. Louis, MO  
January 1989

Litton  
Applied Technology Division  
San Jose, CA  
April 1989

Standard Industries  
LaMirada, CA  
June 1989

Teledyne Industries Incorporated  
Electronics Division  
Newbury Park, CA  
July 1989

Lockheed Corporation  
Missile Systems Division  
Sunnyvale, CA  
August 1989

General Electric  
Naval & Drive Turbine Systems  
Fitchburg, MA  
October 1989

TRICOR Systems, Incorporated  
Elgin, IL  
November 1989

TRW  
Military Electronics and Avionics  
Division  
San Diego, CA  
March 1990

Texas Instruments  
Defense Systems & Electronics Group  
Dallas, TX  
June 1988

Bell Helicopter  
Textron, Inc.  
Fort Worth, TX  
October 1988

GTE  
C3 Systems Sector  
Needham Heights, MA  
November 1988

Northrop Corporation  
Aircraft Division  
Hawthorne, CA  
March 1989

Litton  
Amecom Division  
College Park, MD  
June 1989

Engineered Circuit Research, Incorporated  
Milpitas, CA  
July 1989

Lockheed Aeronautical Systems Company  
Marietta, GA  
August 1989

Westinghouse  
Electronic Systems Group  
Baltimore, MD  
September 1989

Rockwell International Corporation  
Autonetics Electronics Systems  
Anaheim, CA  
November 1989

Hughes Aircraft Company  
Ground Systems Group  
Fullerton, CA  
January 1990

MechTronics of Arizona, Inc.  
Phoenix, AZ  
April 1990

---

Boeing Aerospace & Electronics  
Corinth, TX  
May 1990

Textron Lycoming  
Stratford, CT  
November 1990

Naval Avionics Center  
Indianapolis, IN  
June 1991

Kurt Manufacturing Co.  
Minneapolis, MN  
July 1991

Raytheon Missile Systems Division  
Andover, MA  
August 1991

Tandem Computers  
Cupertino, CA  
January 1992

Conax Florida Corporation  
St. Petersburg, FL  
May 1992

Hewlett-Packard  
Palo Alto Fabrication Center  
Palo Alto, CA  
June 1992

Digital Equipment Company  
Enclosures Business  
Westfield, MA and  
Maynard, MA  
August 1992

NASA Marshall Space Flight Center  
Huntsville, AL  
January 1993

Department of Energy-  
Oak Ridge Facilities  
Operated by Martin Marietta Energy Systems, Inc.  
Oak Ridge, TN  
March 1993

Technology Matrix Consortium  
Traverse City, MI  
August 1990

Norden Systems, Inc.  
Norwalk, CT  
May 1991

United Electric Controls  
Watertown, MA  
June 1991

MagneTek Defense Systems  
Anaheim, CA  
August 1991

AT&T Federal Systems Advanced  
Technologies and AT&T Bell Laboratories  
Greensboro, NC and Whippany, NJ  
September 1991

Charleston Naval Shipyard  
Charleston, SC  
April 1992

Texas Instruments  
Semiconductor Group  
Military Products  
Midland, TX  
June 1992

Watervliet U.S. Army Arsenal  
Watervliet, NY  
July 1992

Naval Aviation Depot  
Naval Air Station  
Pensacola, FL  
November 1992

Naval Aviation Depot  
Naval Air Station  
Jacksonville, FL  
March 1993