

SACLANT UNDERSEA RESEARCH CENTRE REPORT

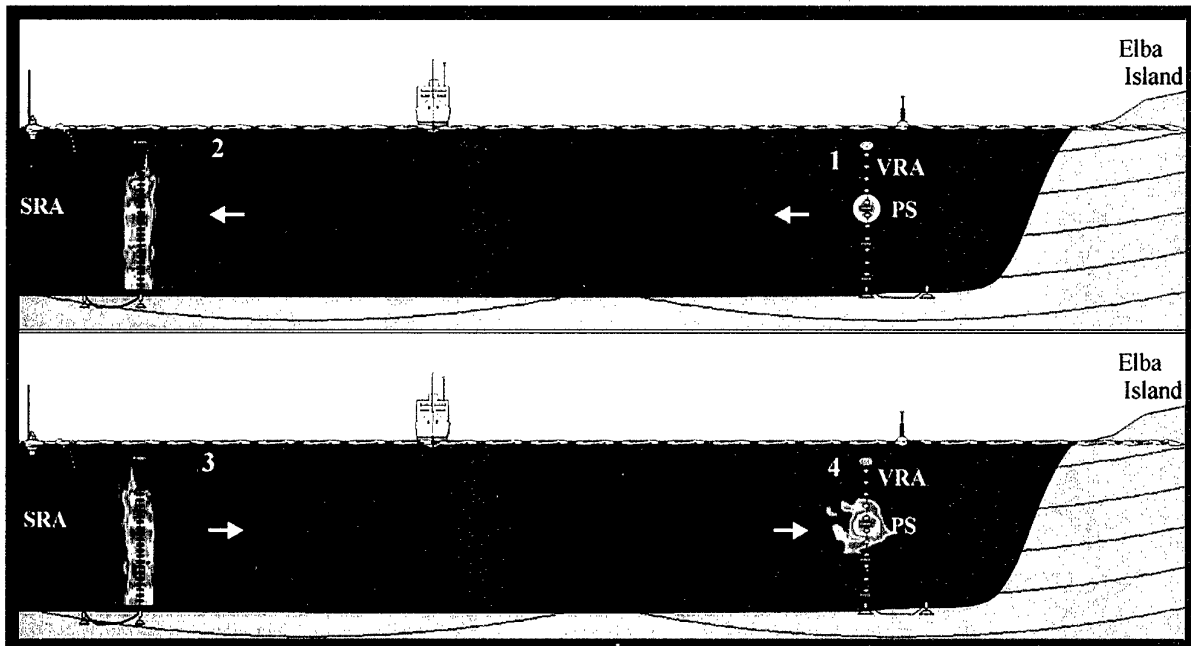

DISTRIBUTION STATEMENT A
Approved for Public Release
Distribution Unlimited

20020107 125

Underwater acoustic
communication using time-reversal
self-equalization

Geoffrey F. Edelmann, Tuncay Akal,
William S. Hodgkiss, Seongil Kim,
William A. Kuperman, Hee Chun Song,
Piero Guerrini.

The content of this document pertains to
work performed under Project 06-B of the
SACLANTCEN Programme of Work.
The document has been approved for
release by The Director, SACLANTCEN.



Jan L. Spoelstra
Director

intentionally blank page

Underwater acoustic communication using time-reversal self-equalization

Edelmann, G.F., Akal, T., Hodgkiss, W.S., Kim, W., Kuperman, W.A.,
Song, H.C., Guerrini, P.

Executive Summary: The first two in the series of Focused Acoustic Field (FAF) experiments took place in 1996 and 1997 using a 450 Hz source/receive array off the Island of Formiche. These were the first experiments to implement and demonstrate time reversal in the ocean. Focal distances of up to 30 km at a depth of approximately 100 m were demonstrated. The third experiment at 3500 Hz, demonstrated the sharp focusing ability of the TRM and the potential for communications.

The fourth experiment (FAF 2000) was conducted during the period 19 May to 15 June 2000, to demonstrate that a time reversal mirror (TRM) or phase conjugate array, can spatially and temporally refocus an incident acoustic field back to its origin. Although there has been some progress in overcoming the time-varying dispersion that can destroy coherent digital information, fast and reliable data rates remain elusive. Time reversal was applied to the communications problem and shown to be an effective technique to counter the inter-symbol interference caused by multipath dispersion. A substantial advantage of time-reversal self-equalization over one-way single source communications and to a lesser extent, one-way broadside (nearly single mode) communications, was demonstrated.

SACLANTCEN SR-341

intentionally blank page

Underwater acoustic communication using time-reversal self-equalization

Edelmann, G.F., Akal, T., Hodgkiss, W.S., Kim, W., Kuperman, W.A.,
Song, H.C., Guerrini, P.

Abstract: Though underwater acoustic communications has made great strides in overcoming the time-varying dispersion that can destroy coherent digital information, quick and reliable data rates have remained elusive. Time reversal was applied to the communications problem and shown to be an effective communications technique that counters the inter-symbol interference caused by multipath dispersion. A substantial advantage of time-reversal self-equalization over one-way single source communications and, to a lesser extent, advantage over one-way broadside (nearly single mode) communications was demonstrated.

Keywords:

Contents

1. Introduction	1
2. Digital communications.....	2
2.1 Phase shift keying (PSK)	2
2.2 Communications sequence	2
2.3 Receiver design	3
2.4 In-phase and quadrature plot	4
3. Time reversal mirror experiment.....	5
3.1. Operating area	5
3.2. Ocean acoustic environment	7
3.3. Range independent configuration	9
3.4. Range dependent configuration	10
3.5 Measured time reversal foci	10
4. Underwater acoustic communication.....	12
4.1 Time reversal self-equalization	13
4.2. Single source transmission.....	13
4.3 Broadside transmission	13
4.4 Range independent communication results	13
4.5 Range dependent communication results	15
4.6 Bit error rate versus depth	16
5. Underwater acoustic communications.....	17
5.2 Operator using TRM to communicate to AUV	17
5.3 AUV using TRM to communicate to its operator	18
References	19

1

Introduction

A series of time-reversal mirror (TRM) experiments in shallow water have been implemented at centre frequencies of 450 Hz [1,2,3] and 3500 Hz [4]. A TRM, also referred to as a phase conjugate array, focuses sound from an array of source/receive elements back to the probe source. If the ocean does not change significantly during the two-way travel time, the phase conjugate field will refocus regardless of the complexity of the medium with the caveat that excessive loss in the system degrades the focus. During this experiment, communication sequences were transmitted and measured which took advantage of the temporal and spatial focusing properties of the TRM.

Time-reversal can be seen as a matched filter performing the autocorrelation of impulse response of the waveguide [5,6]. When a known signal $s(t)$ is transmitted from a source in a waveguide, it is convolved with the impulse response of the waveguide, $h_i(t)$, and the signal $r_i(t)=s(t)\otimes h_i(t)$ is received on the i^{th} element of the TRM, an array of N source/receive transducers. The TRM receives $r_i(t)$ and retransmits the time reversed version of it, $r_i(-t)$. Thus time-reversal is a matched filter implementing the autocorrelation of the impulse response of the waveguide. The signal received back at

$$S_r(t) = \sum_{i=1}^N S_i(-t) \otimes (h_i(-t) \otimes h_i(t))$$

the original source location, $s_r(t)$, can be written as:

The time-reversed version of the dispersed multipath signal focuses back to its origin [7]. The quality of the time-reversal focus is improved with more TRM elements. On the time scales of interest, the ocean must be sufficiently linear and time invariant for time-reversal to work.

Time-reversal can be used as a self-equalization processor in an ocean channel. The TRM relies on the reciprocity property of wave propagation to implement the matched filter of the channel impulse response. In a time-reversal system, the dispersive multipath arrivals recombine at the receiver.

The next section of this report briefly discusses digital communications and encoding. Section III explains the TR experimental setup and shows TR results in range independent and dependent environments. Section IV gives an overview of underwater acoustic communication and time-reversal self-equalization. Section V shows

communication results. Conclusions are made including a discussion of the potential for AUV communications.

2.1 PHASE SHIFT KEYING (PSK)

PSK encodes digital information in the phase of a transmitted pulse. As shown in Fig. 1, one pulse or symbol, can encode one or more bits. For our experiment the pulse length, T , was 2 ms. Using binary phase shift keying (BPSK), one bit of information (1 or 0) is encoded on each symbol, and has two possible phases 180° apart (e.g. 0° and 180°). Quadrature phase shift keying (QPSK) encodes 2 bits (00, 01, 10 or 11) per symbol and has four possible phases (0° , 90° , 180° or 270°). Signal constellations can be created for any arbitrary M -ary PSK (MPSK) system. Higher constellations increase the probability of bit error. Bit error occurs when the phase of a symbol is incorrectly decoded back to digital information. Increasing M or shortening the length of the pulse T can achieve greater data transfer rates. Using BPSK encoding we achieved a data rate of 500 bits/s.

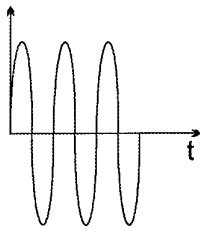

Figure 1 One pulse (symbol).

2.2 COMMUNICATIONS SEQUENCE

Digital information is encoded as a time series composed of many symbols. This sequence of pulses, ready for transmission, is called a communication sequence. For statistical analysis of bit error, thousands of symbols must be received and decoded. The BPSK sequence pictured in Fig. 2 is composed of symbols with two possible phases that are 180° apart (± 1 in amplitude). The 8 symbol long sequence encodes the 8 bits: 0 0 1 0 0 1 1 1.

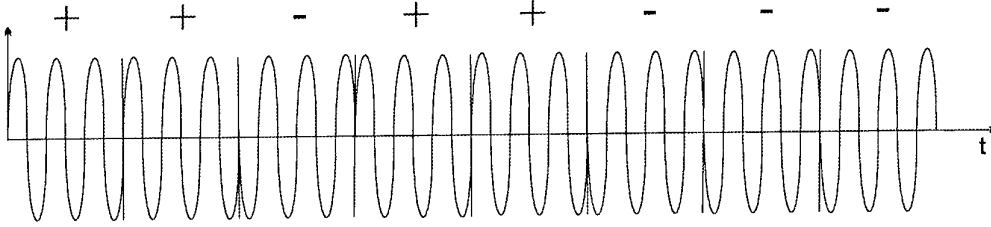

Figure 2 An 8 bit communication sequence encoded by BPSK

2.3 RECEIVER DESIGN

The synchronized integrate-and-dump receiver shown in Fig. 3 was used to decode the communication sequences. The receiver is synchronized so it knows the starting time and pulse length of each symbol. It calculates the in-phase and quadrature components of the symbol and then integrates them. The real and imaginary output of the integrate-and-dump receiver, shown in Fig. 3, is that symbol's location in the complex plane. For example, BPSK encodes only 1 bit per symbol. Without noise or inter-symbol interference (ISI) there would only be two points, 180° apart in the real imaginary plane, representing a '1' or a '0' received bit. The decision output is the closest Euclidean distance from the symbol position to the ideal positions.

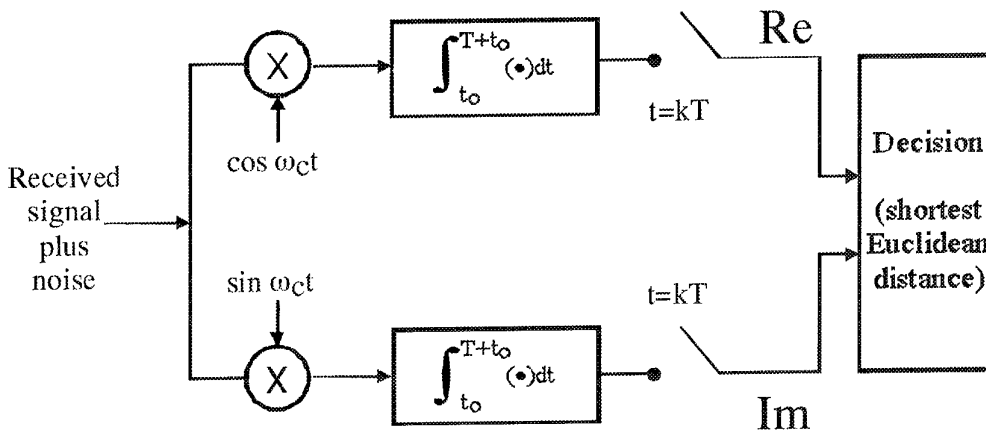

Figure 3 Schematic of a synchronized integrate-and-dump receiver.

3

Time reversal mirror experiment

The experiment conducted during the period of May 19 to June 15 2000 was the 4th in the series of SACLANTCEN/MPL Focused Acoustic Field (FAF) experiments. The first two in 1996 and 1997 used a 450 Hz source/receive array that was connected to Formiche Island. These were the first experiments to implement and demonstrate time reversal in the ocean. At 450 Hz, focal distances of up to 30 km in approximately 100 m water were demonstrated. The third experiment was carried out at 3500 Hz and demonstrated the sharp focusing ability of the TRM and the potential for communications. The recent experiment, entitled FAF2000, was carried out north of Elba as shown in Fig. 5. The centre frequency of the sources used in this experiment was 3500 Hz. During a portion of the cruise, communication sequences were transmitted and received that demonstrate statistically the potential of time-reversal as a communication technique.

3.1 OPERATING AREA

Figure 5 shows the operating area of the FAF2000 experiment off of the northern coast of Elba Island. Oceanographic moorings are shown with one of the array configurations. The coloured rectangular area is Hydrosweep measured bathymetry. The moorings were fixed throughout the experiment. The vertical receive array is shown in its two positions: the first for range-independent communications and the second for range-dependent communications.

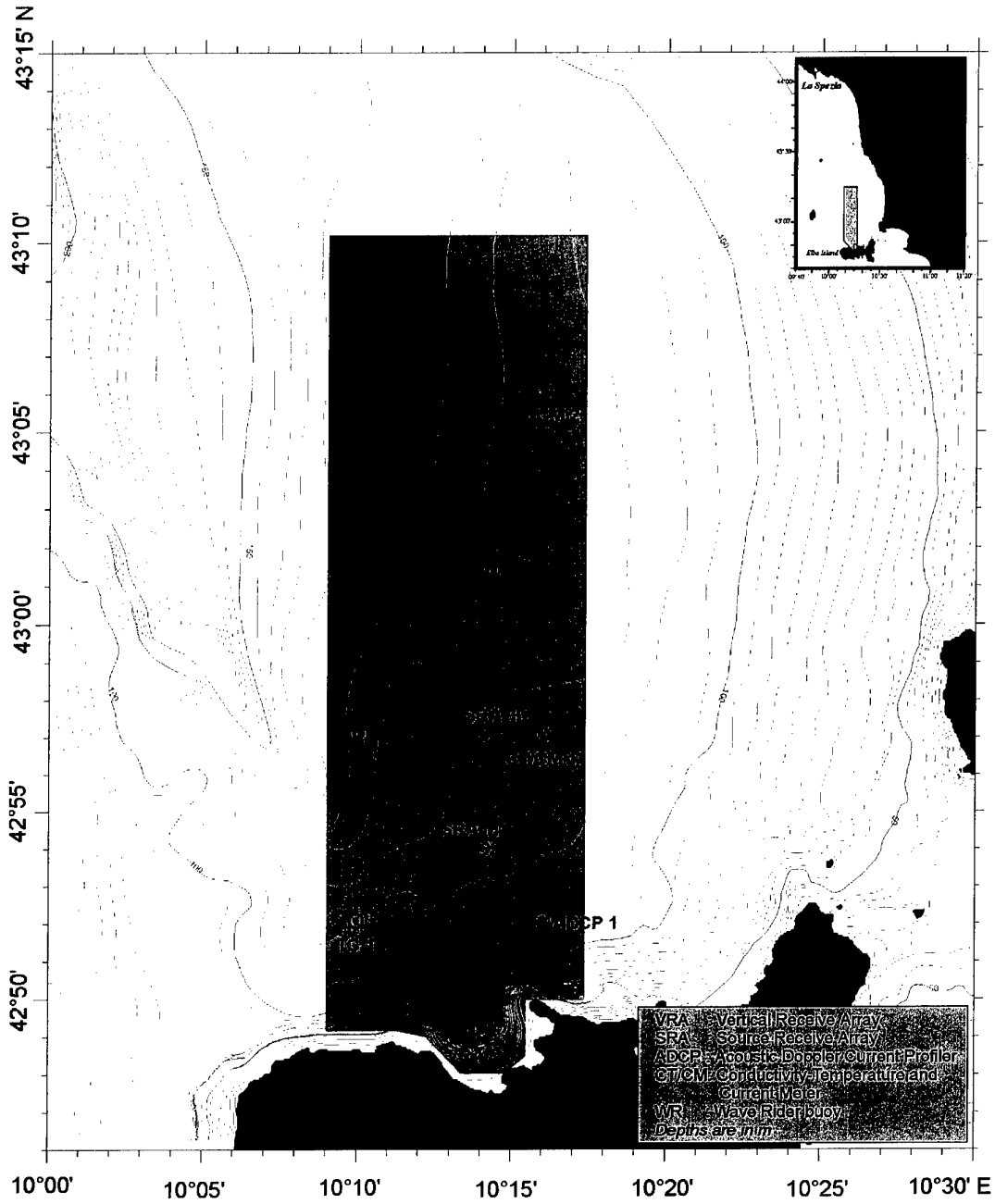
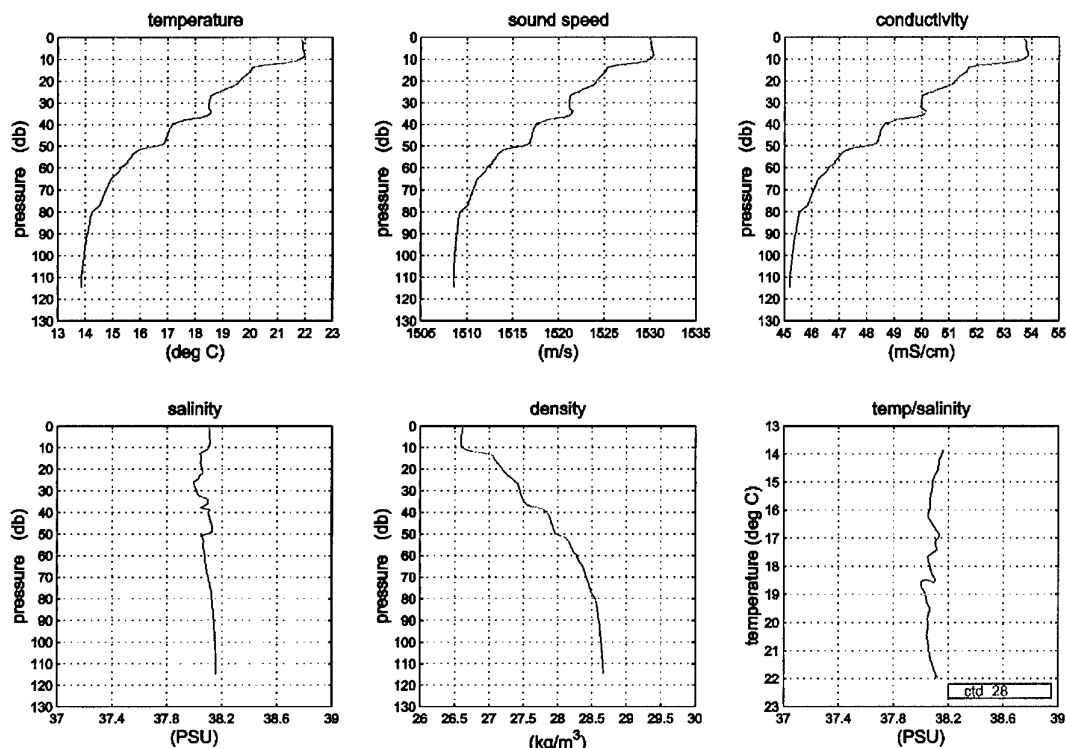

Figure 5 The FAF2000 experiment showing oceanographic moorings and of the SRA/VRA configurations. The coloured rectangular area is an actual Hydrosweep bathymetry result.

3.2 OCEAN ACOUSTIC ENVIRONMENT

The ocean environment was quite variable throughout this experiment. CTD's taken from the *Alliance*, as shown in Fig. 6, indicate density gradients which are, by preliminary analysis, proving to have a profound effect on the properties of the focal region. An example of the spatio-temporal variability is shown in Fig. 7 for 9 CTD sites as obtained by the *Manning* on three successive days. There is a very distinct spatial dependence on the profiles. When the oceanographic moorings are interpreted, this experiment will no doubt prove to contain a rich ocean acoustic data set as well as a valuable oceanographic data set by itself.



-FAF2000- CTD 28 42 56:66N 10 13.60E @07:30 5 June 2000

Figure 6 Sample soundspeed profile taken from the *Alliance*.

Spatial and time Variability of Sound Speed during 7,8 and 9 June

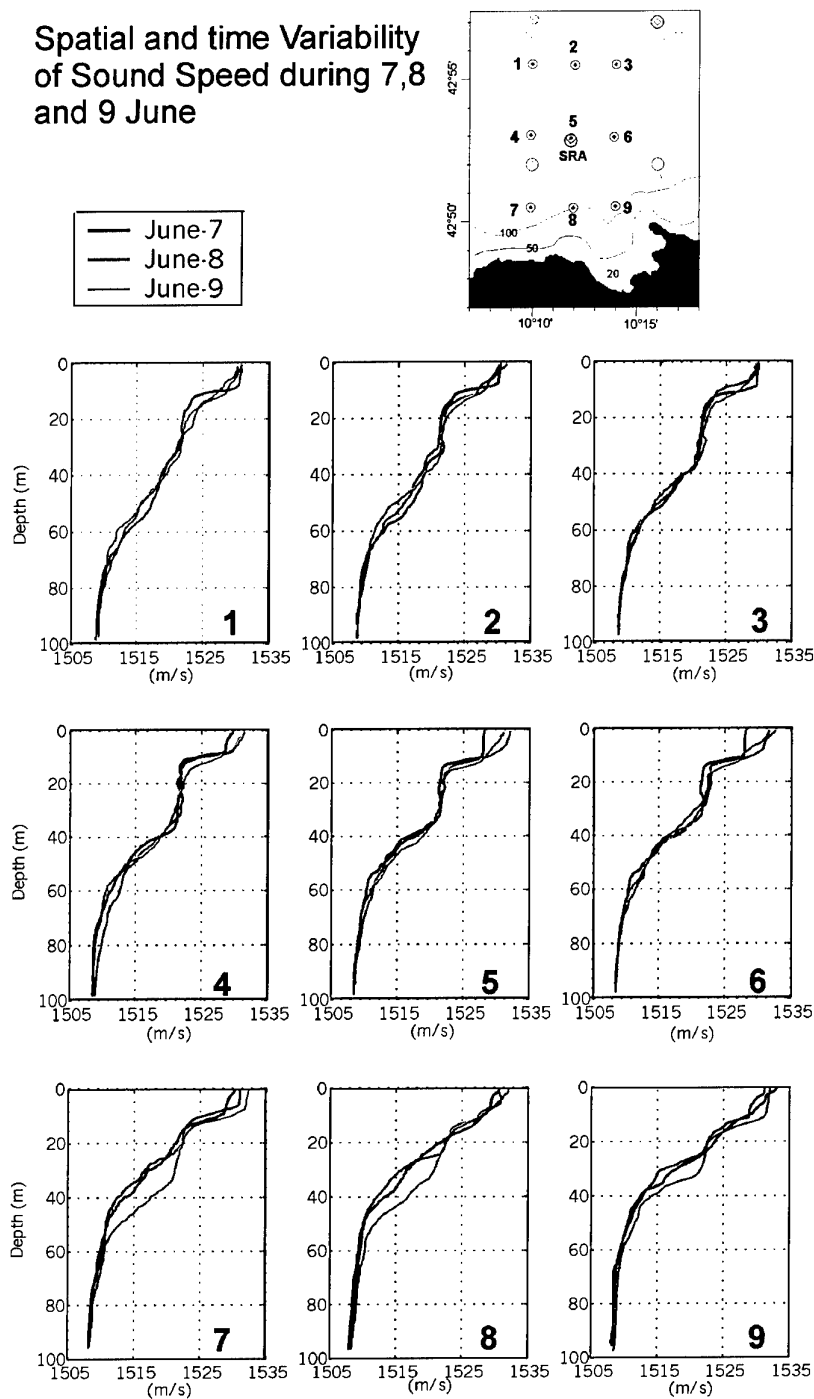

Figure 7 Sound speed profiles on three consecutive days at nine different positions derived from CTD's taken by the Manning.

3.3. RANGE INDEPENDENT SETUP

The schematic in Fig. 8 illustrates the components of a TRM experiment. A probe source (PS), indicated by one of the rectangles on the vertical receive array (VRA), sends out a pulse that is received at the source-receive array (SRA). The dispersed signal with all its multipath structure is time reversed and retransmitted by the SRA. The resulting signal multipath structure collapses to a spatial and temporal focus (original PS pulse length) at the original PS position that is co-located in range with the VRA.

1. PS Transmits 2 ms Pulse

2. SRA Receives the Transmission

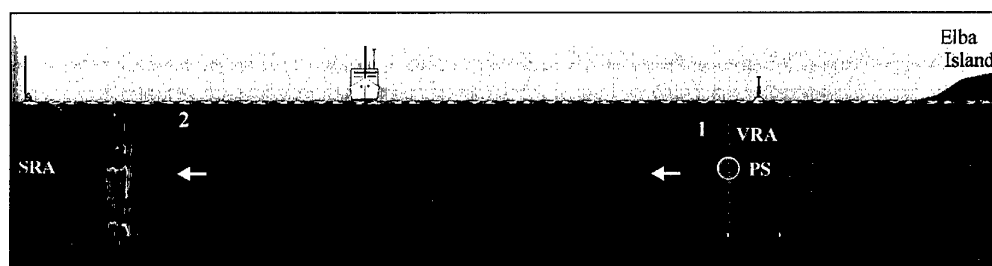

3. SRA Time Reverses and Retransmits

4. VRA Receives the Focused Signal

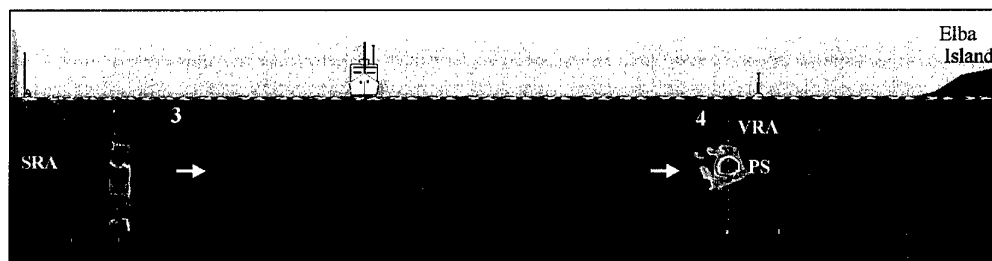

Figure 8 Experimental setup for time reversal mirror experiment. Probe sources (PS) are indicated by the larger rectangles directly attached to VRA. The first step is the transmission of a 2 ms PS pulse. The source receive array (SRA) receives the channel response. The SRA time-reverses and retransmits the channel response. The acoustic energy focuses spatially and temporally to the original PS location where the VRA is collocated to measure that focus.

During the range independent communications portion of the experiment the SRA was in 112 m water depth and at a range of 10 km from the VRA. The VRA had 32 elements with 3 m spacing. There were three PS collocated with the VRA at approximately 40, 60 and 80 m water depth. The PS had a centre frequency of 3.5 kHz which corresponds to a wavelength (λ) of 0.43 m in the ocean. The SRA consisted of 29 source/receive transducers with an inter-element spacing of 2.78 m so it had a total aperture of 78 m or 181 λ . The transducers had an effective bandwidth of 1 kHz with a nominal transmission level of 174 dB.

3.4 RANGE DEPENDENT SETUP

During the range dependent portion of the experiment the SRA was located in 112 m deep water. The SRA was operated remotely from the *Alliance* which was 9.8 km south and in 40 m deep water as shown in Fig. 9. The VRA and PS were deployed off of the *Alliance* in the second configuration of Fig. 5. The VRA was partially out of the water and had 2 m inter-element spacing. Extremely sharp focal regions were obtained as shown in Fig. 10.

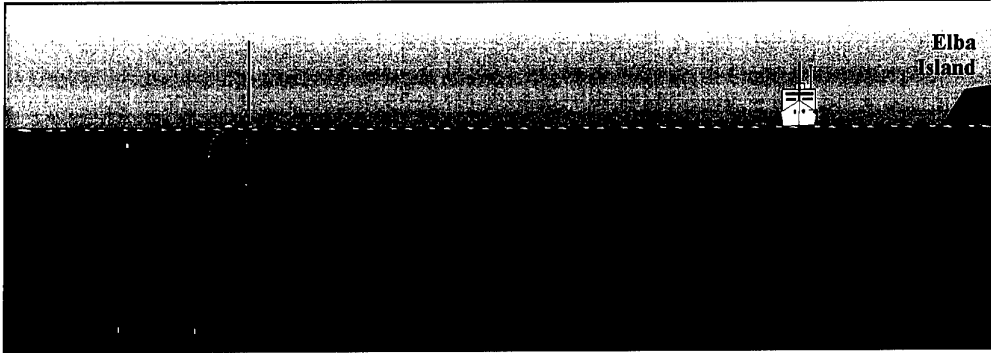

Figure 9 *Experimental geometry for the range dependent time-reversal focus experiment.*

3.5 MEASURED TIME REVERSAL FOCI

Sample time series are shown as normalized logarithmic contour plots with dynamic range of 20 dB in Fig. 10 for range independent and dependent environments, taken prior to the transmission of the communication sequences. The original 2 ms PS pulse has spread to 15 ms in the flat region and over 20 ms in the upslope region. Note that there two hydrophones are not functioning. After time-reversal and retransmission the foci recorded on the VRA are shown in the lower two panels. The focus in the upslope region was recorded in shallow water, so the vertical depth scale is only 35 m. The temporal and spatial compression is clearly visible.

Range Independent

Range Dependent

Acoustic field @ SRA

Acoustic field @ SRA

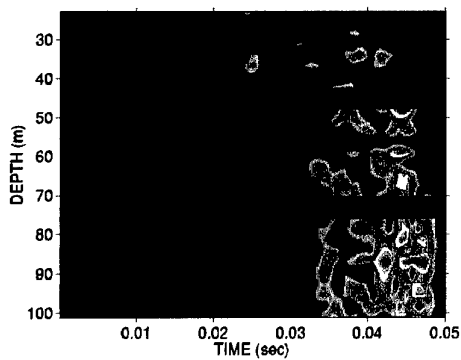
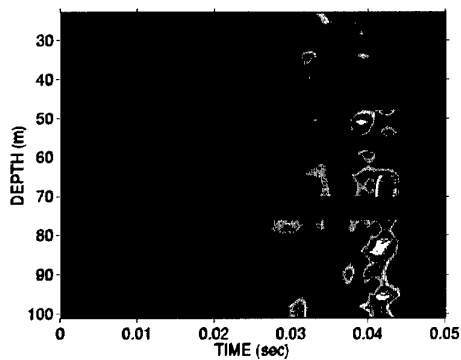

Acoustic Field @ VRA

Acoustic Field @ VRA

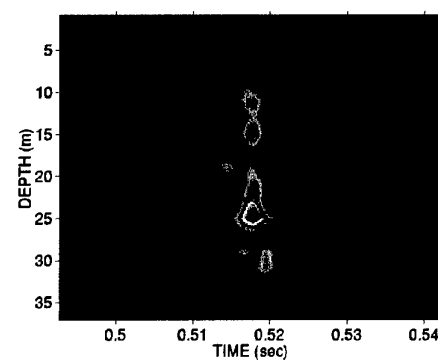
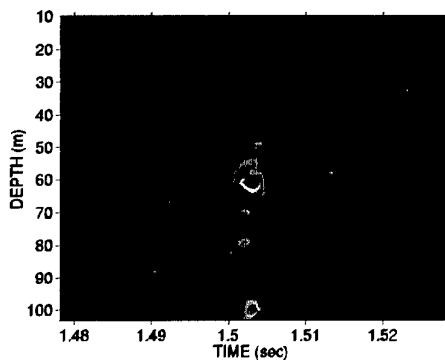

Figure 10 Example time series measured during the TR experiment. The left hand column shows a range independent focus in the Island of Elba area. The right hand column depicts a range dependent focus in the upslope region. There is more dispersion in the sloped region. Note the depth scale change on the upslope TR focus, the vertical focus is less than ± 1 m.

4

Underwater acoustic communication

Though much progress has been made in ocean acoustic telemetry in the past 30 years, reliable high speed communications has remained elusive [8]. Coherent underwater acoustic communication systems, such as adaptive channel equalization, have become the favored method to deal with the inter-symbol interference (ISI) caused by time-varying multipath environments [9, 10]. The application of the time-reversal methods for underwater acoustic communications has already been suggested [11] and some calculations for the 3500 Hz pulse with a kilohertz bandwidth have [12] demonstrated the temporal multipath recombination and sidelobe suppression needed for underwater communications. Time-reversal communication sequences were transmitted and measured during the experiment. As a comparison to TR, single source and broadside communication transmissions were also made.

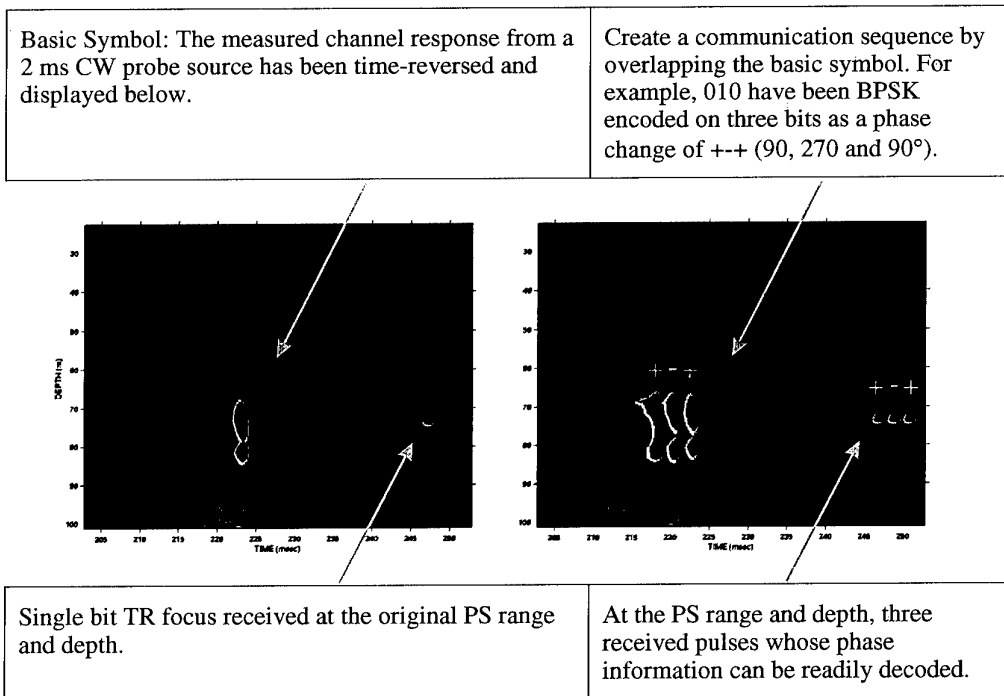

Figure 11 The creation of a time-reversal self-equalization communication sequence.

4.1 TIME-REVERSAL SELF-EQUALIZATION

Time-reversal self-equalization is a 2-way method of communication that takes advantage of the focusing ability of the time-reversal mirror. A channel is excited by a probe source and its channel response is recorded on the TRM and time-reversed as shown in the left panel of Fig. 11. This entire channel response represents the basic symbol we will use in PSK encoding. For example in BPSK encoding, the channel response is encoded with ± 1 polarity (0° or 180°). The entire channel response is copied every 2 ms, with the copies substantially overlapping each other as shown in the right panel. After retransmission the individual symbols compressed nicely back to their original 2 ms duration.

4.2 SINGLE SOURCE TRANSMISSION

Basic 1-way ocean communication is carried out by a single source transmitting to a receiver. Measurements of a single element of the SRA transmitting communication sequences to the VRA were made. Single source transmissions are the most prone to the negative effects. The acoustic energy is spread vertically at the receiver.

4.3 BROADSIDE TRANSMISSION

Broadside transmission is another method of 1-way communication which uses all the elements of the SRA to transmit simultaneously the communications sequence. Broadside transmission approximates single-mode excitation. The ocean waveguide supports the transmission of a discrete set of modes. For the purpose of communication, transmitting a single mode would suppress dispersion and therefore ISI. Exciting exactly a single mode in shallow water experiments has proven quite difficult and requires more complicated feedback control systems [13]. A simple broadside is about as effective at exciting the first mode as trying to shade the array with the first mode shape. PSK communication sequences were transmitted using a full broadside of the 29 sources of the TRM. While broadside transmissions can suppress dispersion, the acoustic energy transmitted is incapable of breaking out of the shape of the first mode.

4.4 RANGE INDEPENDENT COMMUNICATION RESULTS

The communication experiments were performed in the fixed-fixed configuration with both the VRA and SRA operated remotely. A 2 ms CW probe source signal was received at the SRA and time reversed thereby creating the basic symbol for the communication sequence as described above. A random data sequence was generated and encoded using time-reversal self-equalization. BPSK communication results are shown in Fig. 12. For comparison, broadside and single source one-way communications experiments were also measured.

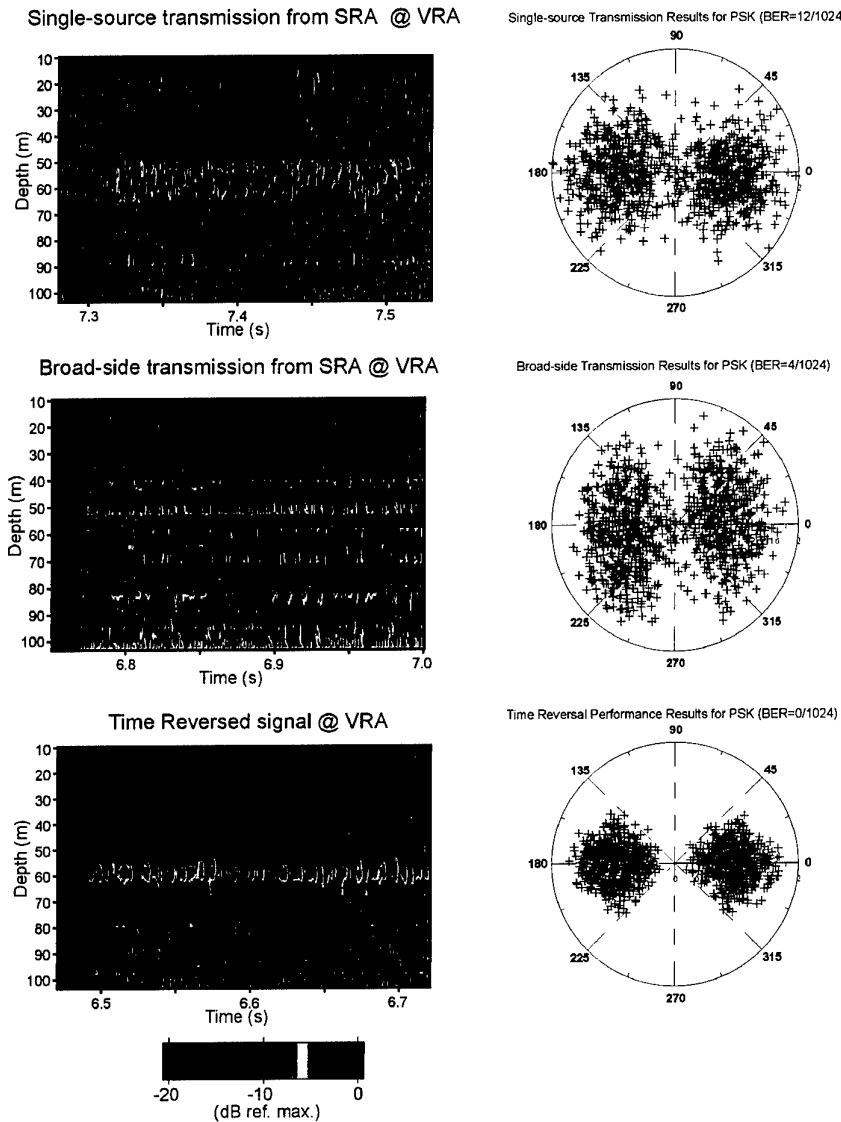

Figure 12 Range independent: An example of time reversal communication result compared to the other one-way transmission control examples (single-source and broadside). Bit error rate is denoted as BER The data rate was 500 bit/s.

The in phase and quadrature plots on the right are an indication of the robustness of the communications process. With no noise or ocean variability, one would expect only two dots on the real axis at plus and minus one. Preliminary analysis suggests successful decoding with the best results from the time reversal process. The PS depth was considered the target depth for communication.

4.5 RANGE DEPENDENT COMMUNICATION RESULTS

Range dependent communication sequences were also transmitted in the geometry described in Fig. 9. All the communication sequences were performed in 5 and 10 second bursts. An example of a TR, broadside and single source communications are shown in Fig. 13.

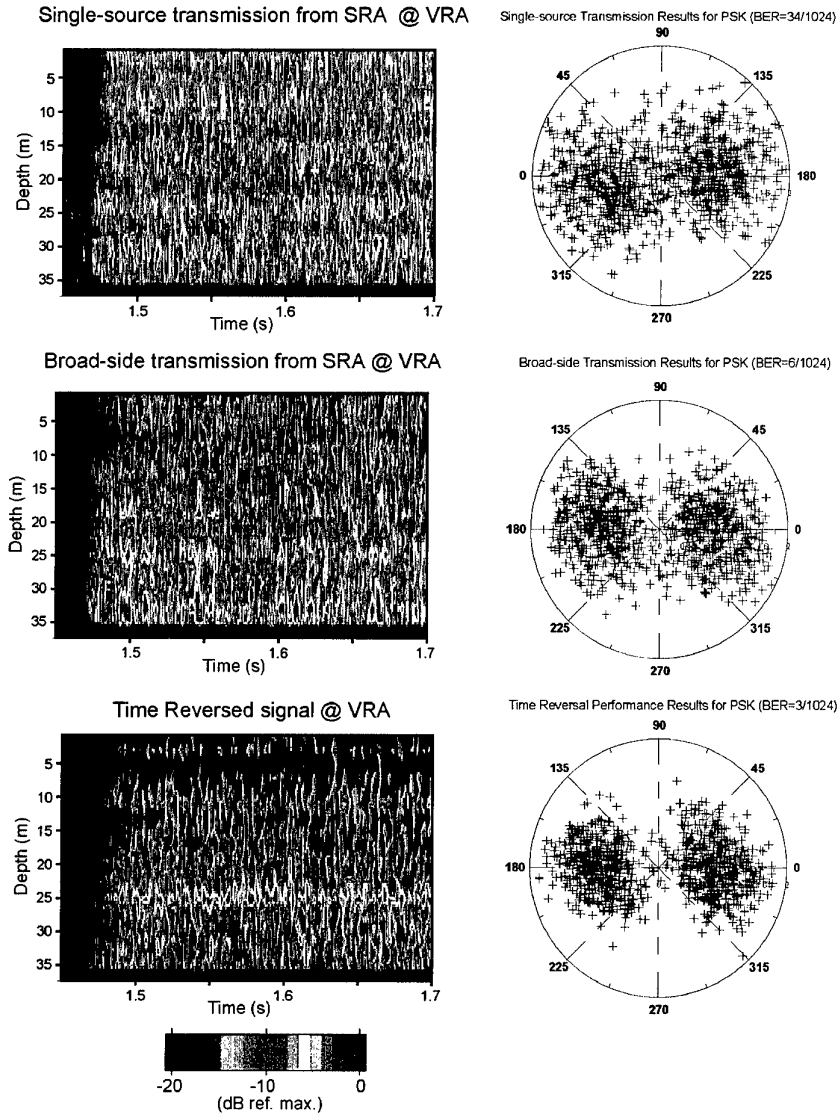

Figure 13 Range dependent environment: An example of time reversal communication result compared to the other one-way transmission control examples (single-source and broadside). Bit error rate is denoted as BER.

4.6 BIT ERROR RATE VERSUS DEPTH

TR provides selectivity in the vertical acoustic energy distribution, potentially allowing communication with targets at any depth. Figure 14 shows the percentage of bits correct as a function of depth for the three communication types. The left panel depicts the range independent communication results and the right panel depicts the range dependent communication results. The number of bits correct in the TR case tends to take on the focal shape. Unlike the single source and broadside, TR focuses energy back to the PS depth. Another property of TR is that the focus quickly decays both in depth and ranges other than the true PS range. This suggests TR communication has low probability of intercept (LPI) applications.

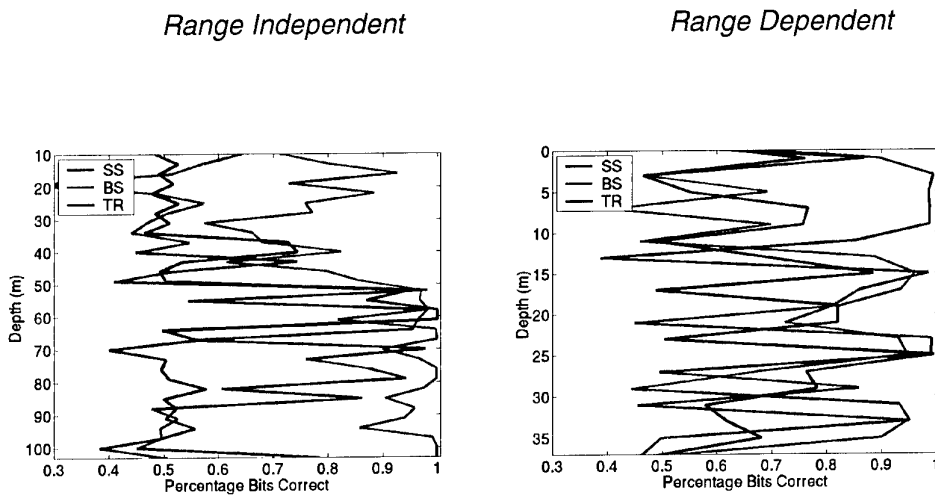

Figure 14 Percentage of bits successful received and decoded versus depth. The three different communication types are shown. Time reversal (TR), broad side (BS) and single source (SS) results are shown.

5

Conclusions

5.1 UNDERWATER ACOUSTIC COMMUNICATIONS

We have shown that TRM can provide an effective means of communications in shallow water environments at ranges of 10 km. Furthermore TR foci were measured up to ranges of 20 km at 3500 Hz. Because of its LPI properties it has potential applications in ship to submarine or submarine to submarine communication scenarios.

5.2 OPERATOR USING TRM TO COMMUNICATE TO AUV

Fast and reliable underwater acoustic communications are essential for the operation of autonomous underwater vehicles (AUV) in shallow water. AUV's are remote sensor platforms capable of conducting covert operations. Figure 15 shows an experimental schematic for time-reversal self-equalization with an AUV. It also summarizes the salient issues and advantages of TR communications. In this scenario the AUV should be considered the PS.

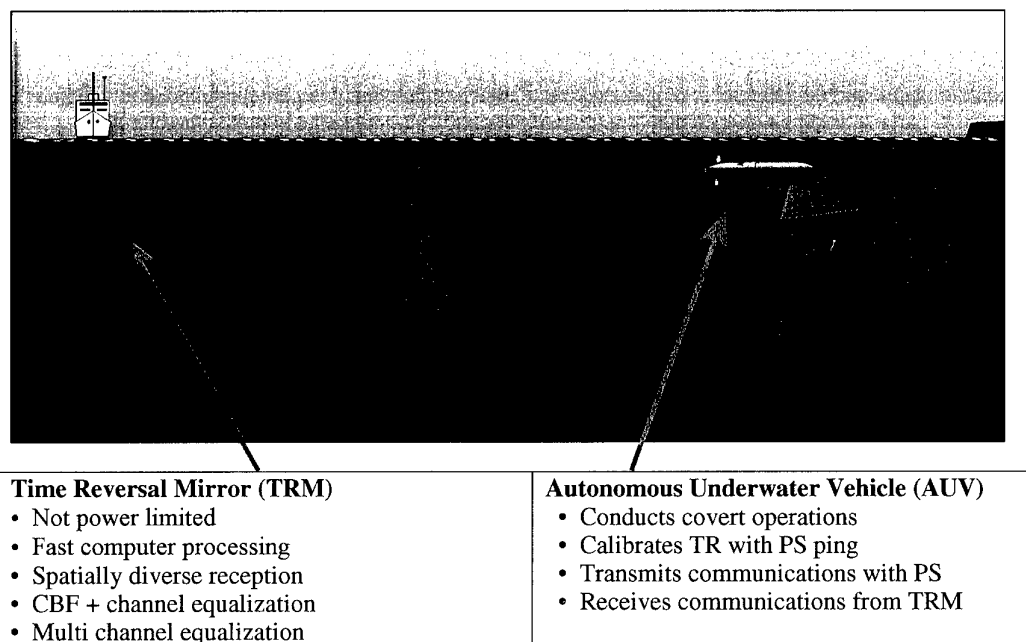

Figure 15 *Experimental configuration for TR communications with AUV.*

Shallow water environments, especially range dependent ones, are characterized as time varying and dispersive as we have shown. Advance coherent communications techniques can be used to counter the ISI. When the AUV communicates to the source receive array, the SRA has access to the computing power and spatial diversity necessary for multichannel adaptive equalization [8]. Alternatively, conventional beamforming (CBF) could be used in conjunction with single channel adaptive equalization [14]. This is the same communication scenario as discussed for range dependent single source communications.

However, when the SRA is communicating with the AUV, the AUV is limited in processing power and lacks spatial diversity. We have shown that using time-reversal self-equalization we were able to transmit information that fights dispersion and also propagated acoustic energy to the PS depth and range. Therefore time-reversal self-equalization acts as a preprocessor overcoming the AUV's limitations.

The results also suggest that self-equalization could be used in conjunction with existing adaptive equalizers as a pre-filter. This would reduce the number of taps (filter weights) an adaptive equalizer would require. If the AUV has access to an adaptive equalizer it could extend the period of time the TRM can communicate between PS pings.

5.3 AUV USING TRM TO COMMUNICATE TO ITS OPERATOR

A TRM can be deployed from the payload of an AUV to communicate with its operator. This is the reciprocal experimental setup where the AUV has the spatial diversity necessary for TRM communications. Since the AUV is in shallow water it needs a short array to adequately span the water column.

References

- [1] Kuperman, W.A., Hodgkiss, W.S., Song, H.C., Akal, T., Ferla, C., Jackson, D.R. Phase conjugation in the ocean: experimental demonstration of a time reversal mirror. *Journal of the Acoustical Society of America*, **103**, 1998:22-40.
- [2] Hodgkiss, W.S., Song, H.C., Kuperman, W.A., Akal, T., Ferla, C., Jackson, D.R. A long range and variable focus phase conjugation experiment in shallow water. *Journal of the Acoustical Society of America*, **105**, 1999:1597-1604.
- [3] Akal, T., Ferla, C., Kuperman, W.A., Hodgkiss, W.S., Song, H.C., Jackson, D.R. Experimental demonstration of the focused acoustic field in the ocean, SACLANTCEN SR-300.
- [4] Edelmann, G.F., Akal, T., Hodgkiss, W.S., Kim, S., Kuperman, W.A., Song, H.C. An initial demonstration of time-reversal self-equalization for underwater acoustic communication. *Journal of the Acoustical Society of America*, (submitted), 2000.
- [5] Derode, A., Tourin, A., Fink, M. Ultrasonic pulse compression with one-bit time reversal through multiple scattering. *Journal of Applied Physics*, **85**, 1999:6343-6352.
- [6] Parvulescu, A. Matched-signal (Mess) processing by the ocean. *Journal of the Acoustical Society of America*, **98**, 1995:943-960.
- [7] Parvulescu, A., Clay, C.S. Reproducibility of signal transmissions in the ocean. *Radio and Electronic Engineering*, **29**, 1965:223-228.
- [8] Kilfoyle D., Baggeroer, A. The state of the art in underwater acoustic telemetry. *IEEE Journal of Oceanic Engineering*, **25**, 2000:4-27.
- [9] Fink, M. Time reversed acoustics. *Physics Today*, **50**, 1997:34-40.
- [10] Kuperman, W. A., Hodgkiss, W.S., Song, H.C., Akal, T., Ferla C., Jackson, D. Phase conjugation in the ocean: experimental demonstration of an acoustic time-reversal mirror. *Journal of the Acoustical Society of America*, **103**, 1998:25-40.
- [11] Jackson, D.R., Dowling, D.R. Phase conjugation in underwater acoustics. *Journal of the Acoustical Society of America*, **105**, 1999:1597-1604.
- [12] Kuperman, W.A., Hodgkiss, W.S., Song, H.C., Gerstoft, P., Roux, P., Akal, T., Ferla, C., Jackson, D.R. Ocean acoustic time reversal mirror. *Proceedings of the Fourth European Conference of Underwater Acoustics*, pp. 493-498, 1998.
- [13] Buck, J.R., Preisig, J.C., Johnson, M., Catipovic, J. Single-mode excitation in the shallow-water acoustic channel using feedback control. *IEEE Journal of Oceanic Engineering*, **22**, 1997:281-291.
- [14] LeBlanc, L.R., Beaujean, P.J. Spatio-temporal processing of coherent acoustic communication data in shallow water. *IEEE Journal of Oceanic Engineering*, **25**, 2000:40-51.

Document Data Sheet

<i>Security Classification</i> UNCLASSIFIED		<i>Project No.</i> 06-B
<i>Document Serial No.</i> SR-341	<i>Date of Issue</i> July 2001	<i>Total Pages</i> 25 pp.
<i>Author(s)</i> Edelmann, G.F., Akal, T., Hodgkiss, W.S., Kim, W., Kuperman, W.A., Song, H.C., Guerrini, P.		
<i>Title</i> Underwater acoustic communication using time-reversal self-equalization		
<i>Abstract</i> <p>Although there has been some progress in overcoming the time-varying dispersion that can destroy coherent digital information, fast and reliable data rates have remained elusive. Time reversal was applied to the communications problem and shown to be an effective technique to counter the inter-symbol interference caused by multipath dispersion. A substantial advantage of time-reversal, self-equalization over one-way single source communication and to a lesser extent, one-way broadside (nearly single mode) communication, was demonstrated.</p>		
<i>Keywords</i>		
<i>Issuing Organization</i> North Atlantic Treaty Organization SACLANT Undersea Research Centre Viale San Bartolomeo 400, 19138 La Spezia, Italy [From N. America: SACLANTCEN (New York) APO AE 09613]		Tel: +39 0187 527 361 Fax: +39 0187 527 700 E-mail: library@saclantc.nato.int

The SACLANT Undersea Research Centre provides the Supreme Allied Commander Atlantic (SACLANT) with scientific and technical assistance under the terms of its NATO charter, which entered into force on 1 February 1963. Without prejudice to this main task - and under the policy direction of SACLANT - the Centre also renders scientific and technical assistance to the individual NATO nations.

This document is approved for public release.
Distribution is unlimited

SACLANT Undersea Research Centre
Viale San Bartolomeo 400
19138 San Bartolomeo (SP), Italy

tel: +39 0187 527 (1) or extension
fax: +39 0187 527 700

e-mail: library@saclantc.nato.int

NORTH ATLANTIC TREATY ORGANIZATION