

USAARL Report No. 2002-03

# A Novel Design for a Low-Backscatter Optical Aperture

by Clarence E. Rash and John C. Mora

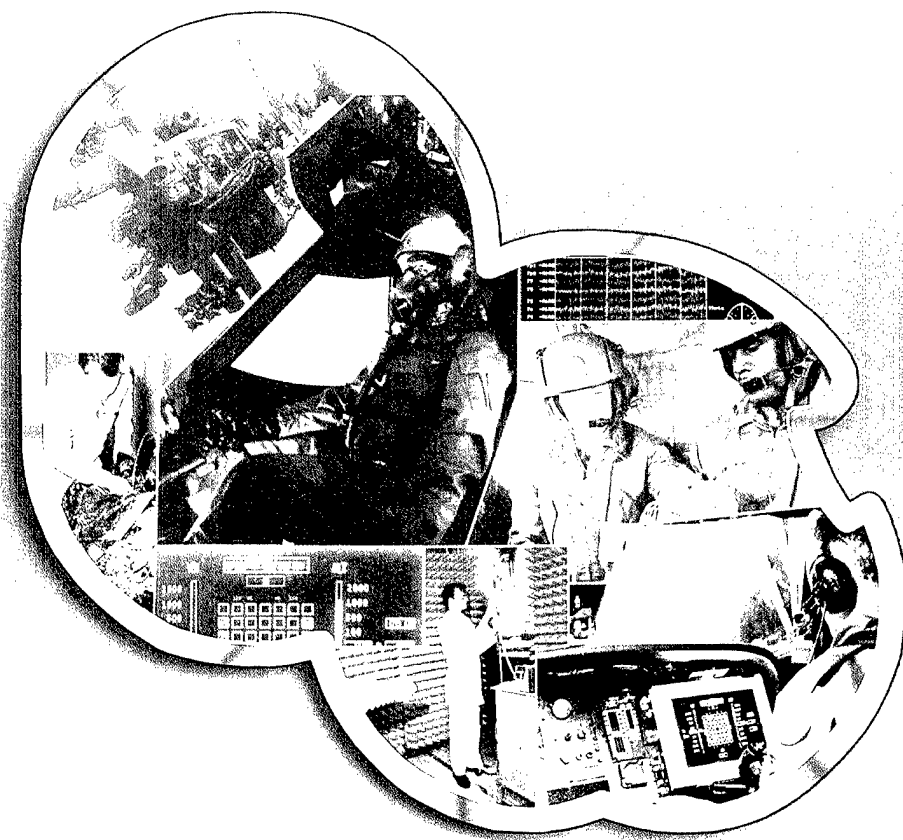

**Aircrew Health and Performance Division**

**November 2001**

Approved for public release, distribution unlimited.

**U  
S  
A  
A  
R  
L**

**U.S. Army  
Aeromedical Research  
Laboratory**

## Notice

### Qualified requesters

Qualified requesters may obtain copies from the Defense Technical Information Center (DTIC), Cameron Station, Alexandria, Virginia 22314. Orders will be expedited if placed through the librarian or other person designated to request documents from DTIC.

### Change of address

Organizations receiving reports from the U.S. Army Aeromedical Research Laboratory on automatic mailing lists should confirm correct address when corresponding about laboratory reports.

### Disposition

Destroy this document when it is no longer needed. Do not return it to the originator.

### Disclaimer

The views, opinions, and/or findings contained in this report are those of the author(s) and should not be construed as an official Department of the Army position, policy, or decision, unless so designated by other official documentation. Citation of trade names in this report does not constitute an official Department of the Army endorsement or approval of the use of such commercial items.

# REPORT DOCUMENTATION PAGE

Form Approved  
OMB No. 0704-0188

1a. REPORT SECURITY CLASSIFICATION <b>Unclassified</b>		1b. RESTRICTIVE MARKINGS	
2a. SECURITY CLASSIFICATION AUTHORITY		3. DISTRIBUTION / AVAILABILITY OF REPORT <b>Approved for public release, distribution unlimited</b>	
2b. DECLASSIFICATION / DOWNGRADING SCHEDULE		4. PERFORMING ORGANIZATION REPORT NUMBER(S) <b>USAARL Report No. 2002-03</b>	
4. PERFORMING ORGANIZATION REPORT NUMBER(S) <b>USAARL Report No. 2002-03</b>		5. MONITORING ORGANIZATION REPORT NUMBER(S)	
6a. NAME OF PERFORMING ORGANIZATION <b>U.S. Army Aeromedical Research Laboratory</b>	6b. OFFICE SYMBOL <i>(If applicable)</i> <b>MCMR-UAD</b>	7a. NAME OF MONITORING ORGANIZATION <b>U.S. Army Medical Research and Materiel Command</b>	
6c. ADDRESS (City, State, and ZIP Code) <b>P.O. Box 620577 Fort Rucker, AL 36362-0577</b>		7b. ADDRESS (City, State, and ZIP Code) <b>504 Scott Street Fort Detrick, MD 21702-5012</b>	
8a. NAME OF FUNDING / SPONSORING ORGANIZATION	8b. OFFICE SYMBOL <i>(If applicable)</i>	9. PROCUREMENT INSTRUMENT IDENTIFICATION NUMBER	
8c. ADDRESS (City, State, and ZIP Code)		10. SOURCE OF FUNDING NUMBERS	
		PROGRAM ELEMENT NO. <b>622787</b>	PROJECT NO. <b>879</b>
		TASK NO. <b>P</b>	WORK UNIT ACCESSION NO. <b>DA336445</b>
11. TITLE (Include Security Classification) <b>A novel design for a low-backscatter optical aperture (U)</b>			
12. PERSONAL AUTHOR(S) <b>Clarence E. Rash and John C. Mora</b>			
13a. TYPE OF REPORT <b>Final</b>	13b. TIME COVERED <b>FROM 04/01 TO 10/01</b>	14. DATE OF REPORT (Year, Month, Day) <b>2001 November</b>	15. PAGE COUNT <b>10</b>
16. SUPPLEMENTAL NOTATION			
17. COSATI CODES		18. SUBJECT TERMS (Continue on reverse if necessary and identify by block number)	
FIELD	GROUP	SUB-GROUP	<b>optics, aperture, backscatter</b>
19. ABSTRACT (Continue on reverse if necessary and identify by block number) <b>Conventional flat aperture designs introduce error and noise in optical/electro-optical applications when the aperture is placed in close proximity to a light source located within the system. Rays that are reflected off the blocked portion of the aperture and then are reflected again off of the light source and reenter the optical path introduce this error. A novel design for a low-backscatter aperture has been introduced and validated for a light measurement application. The new concept is predicated on a V- or cone-shaped aperture design that uses the law of reflection to direct blocked light rays away from the optical path. A light source application was used to validate the new design.</b>			
20. DISTRIBUTION / AVAILABILITY OF ABSTRACT <input checked="" type="checkbox"/> UNCLASSIFIED/UNLIMITED <input type="checkbox"/> SAME AS RPT. <input type="checkbox"/> DTIC USERS		21. ABSTRACT SECURITY CLASSIFICATION <b>Unclassified</b>	
22a. NAME OF RESPONSIBLE INDIVIDUAL <b>Chief, Science Support Center</b>		22b. TELEPHONE (Include Area Code) <b>(334) 255-6907</b>	22c. OFFICE SYMBOL <b>MCMR-UAX-SS</b>

# 20020107 169

## Table of contents

	<u>Page</u>
Introduction .....	1
Aperture design .....	5
Experimental validation .....	8
Summary .....	9
References .....	10

## List of figures

1. A simple optical system .....	2
2. Examples of aperture openings .....	2
3. Ideal (top) and actual (bottom) operation of an aperture with a collimated light source.....	3
4. Ideal (top) and actual (bottom) operation of an uncollimated light source .....	3
5. The law of reflection, depicting the incident and reflected rays .....	4
6. Specular (left) and diffuse (right) reflection .....	4
7. Basic "V"-shaped aperture design showing circular opening .....	5
8. Illustration of the V-shaped low backscatter aperture in operation .....	6
9. Cone-shaped aperture design showing circular opening .....	6
10. Illustration of the cone-shaped low backscatter aperture in operation .....	7
11. Concept of interchangeable aperture openings .....	7
12. Front view (a) of the conventional flat aperture and side (b) and front (c) views of the low-back scatter aperture used in the concept verification measurements .....	8
13. Comparison of lamp readings as a function of aperture distance for conventional and low-backscatter designs .....	9



## Introduction

The control and measurement of light have been important physics and engineering concepts since the development of the first rudimentary optical devices in ancient Greece (Walker, 1998). While centuries of advancements in optics, light generation, and detectors (devices capable of reacting to light energy) have passed, the greatest advancements have been in the last 150 years. For example, while Venetian glass makers discovered the art of applying a combination of mercury and tin to a glass surface in the early 1300s, it was six centuries later in 1840 that the process of silvering, as we know it today, was patented (<http://www.glassresource.com/sub/mirror/mirrhist.htm>, 2001). It was not until the 1940s that photodetectors became common in the measurement of light sources. Prior to this date, visual comparison methods were predominant (Ohno, 1997). Such modern light sources as lasers and light-emitting diodes did not become commonplace until the 1970s (Winburn, 1987) and 1980s, respectively.

During the 1950s, a whole new field, *electro-optics*, emerged. While strictly defined as a field that utilizes the influence of an electric field on optical phenomena, it has been the impetus for the development of new optical materials, detectors and modulators. Electro-optical (EO) systems and their successors have come to dominate virtually all applications where the transfer of energy (signal) is the primary objective.

From elementary optical systems to advanced EO systems, each usually contains or incorporates at least three basic components: a source, a controlling device, and a detector. These components generally are arranged in a serial manner, comprising an optical/EO train. Energy emitted from the source is controlled spatially, spectrally or temporally, and then collected by a detector. Any unwanted change in the energy during this process is referred to as noise.

Whether the task at hand is as simple as measuring the luminance of a lamp or as complicated as using a fiber optic-coupled transceiver for data communication, the ability to control the many variables in the system to prevent unwanted influences (i.e., maintain a high signal-to-noise ratio) is a major goal (Ryer, 1997).

Among the controlling devices (e.g., filters, modulators, attenuators, etc.) are apertures. By definition, an aperture is an opening through which light energy can pass. In simple optics, it can be thought of as an opening at a selected point in an optical system that determines the size of the bundle of light rays that traverse the system. Virtually all optical systems incorporate one or more apertures in their design. Figure 1 depicts a simple optical system consisting of a source (a lamp), an aperture, and a detector (a photometer). Typical roles of apertures are to define a field-of-view (telescopes, microscopes and other imaging optics), the beam convergence/divergence and uniformity (collimating optics), or the size of an image (some reflectance, transmittance or detector response accessories).

Apertures are quite varied in design. Their openings can be circular, square, slit(s), or even unusual in shape (Figure 2). These openings also can vary in size, from pinholes to as large as is practical. In addition, aperture surfaces usually are coated (black) to maximize absorption. But,

one common feature is that virtually all current aperture designs are flat, with the openings in the plane of the aperture. This feature is a source of error in optical measurements and a source of noise (in varying degrees) in all optical systems.

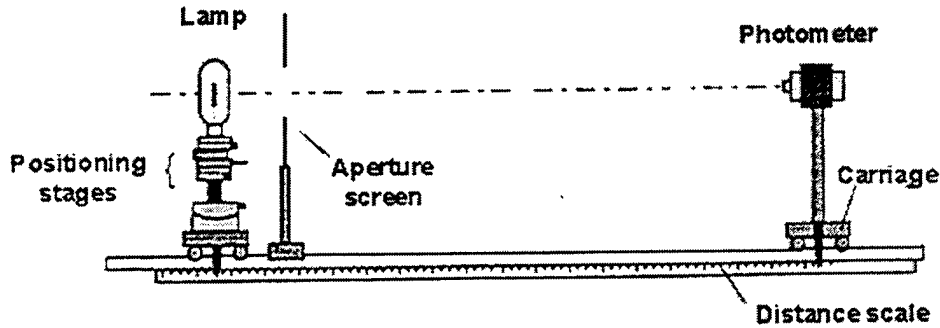

Figure 1. A simple optical system (adapted from DeCusatis, 1997).

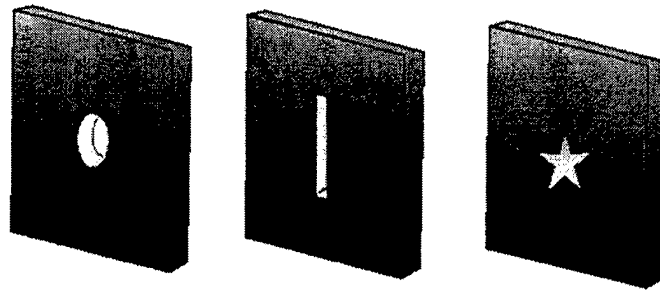

Figure 2. Examples of aperture openings.

One aspect of the problem of current aperture design, which occurs in light source measurement, is illustrated in Figures 3 and 4. Figure 3 (top) depicts the ideal operation of an aperture with a collimated (parallel) light source. Light rays are emitted from the light source (lamp) on the left. These rays travel toward the aperture. The desired rays are passed by the aperture opening. The remaining, undesired rays are blocked by the aperture. These blocked rays ideally disappear (principally through absorption). However, in actual real life operation (Figure 3 (bottom)) these blocked rays do not become nonentities. Some are reflected back unto the light source (backscatter), where they are reflected, again, back into the optical train. This results in a false measure of the intensity (luminance) of the light source by the detector (right). This is also true for uncollimated sources (Figure 4). (Note: For the uncollimated light source example in Figure 4, light rays are shown only for one of many points on the light source.)

In addition, a similar error can be induced by apertures placed near the detector. In this case, reflections from the front surface of the detector can reflect back to and off the aperture and then back into the detector, causing measurement error. The recommended rule-of-thumb to reduce this type of error is to ensure that no aperture is placed within 10 centimeters of the light source

under measurement or of the detector performing the measurement (unless incorporated into the photometer).

While the example above deals only with a very simple optical system used for light source measurement, every optical/EO system suffers from the phenomenon of backscatter that will induce error (noise).

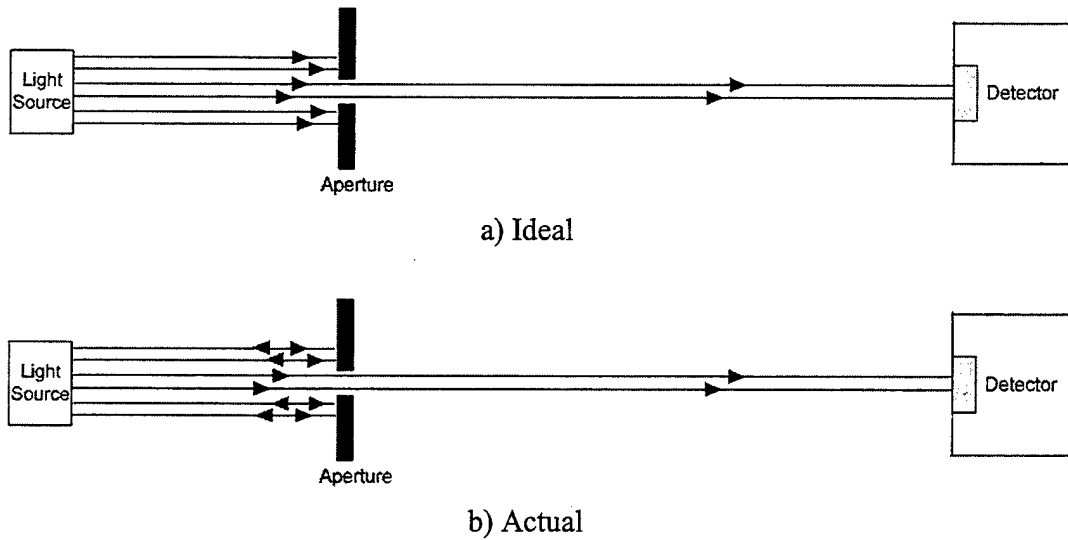

Figure 3. Ideal (top) and actual (bottom) operation of an aperture with a collimated light source. In the actual operation, backscatter results in error (noise).

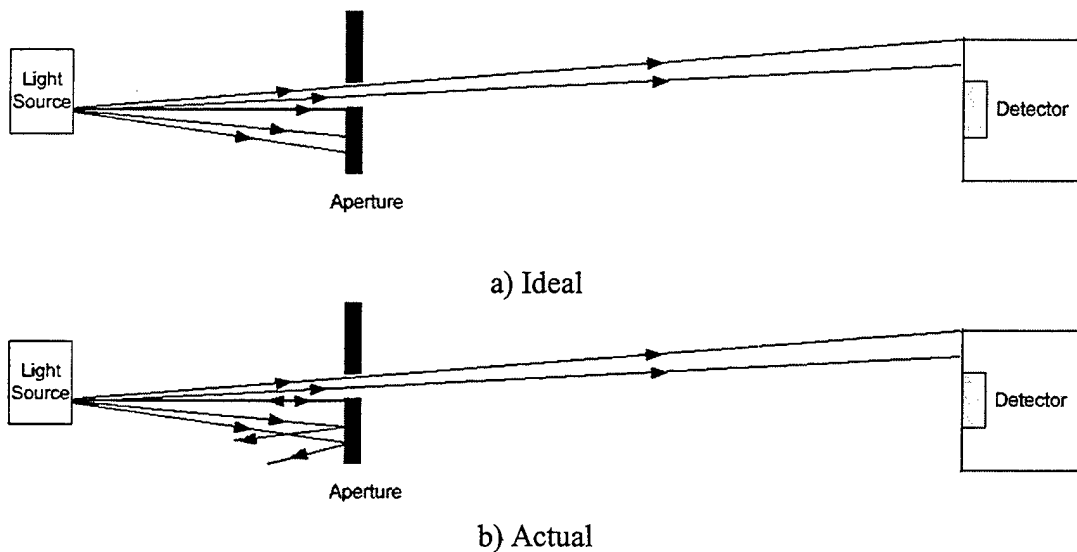

Figure 4. Ideal (top) and actual (bottom) operation of an uncollimated light source. In the actual operation, backscatter results in error (noise).

To further investigate this problem, it may be useful to briefly examine the mechanisms involved using simple ray tracing diagrams. Backscatter is primarily a result of light rays obeying the law of reflection. This law says that when a light ray is incident on a plane surface at an angle,  $\theta$ , to a normal to the surface, the reflected ray also will be at that angle and in the same plane defined by the incident ray and the normal. In other words, the angle of reflection equals the angle of incidence. This law is graphically illustrated in Figure 5.

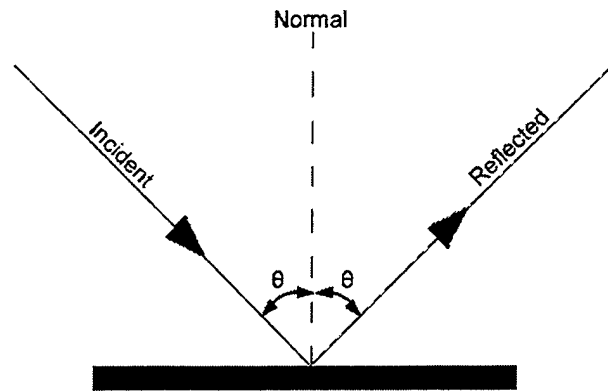

Figure 5. The law of reflection, depicting the incident and reflected rays.

If instead of one ray, we use multiple parallel rays, the application of the law of reflection will result in the situation depicted in the left side of Figure 6. This type of reflection is called *specular* reflection and only results when the surface is so smooth that its irregularities are small, relative to the wavelength of the incident light. However, many surfaces are not microscopically smooth and result in the rays in a parallel beam of light being reflected in all directions (right side, Figure 6). This is called *diffuse* reflection (Beiser, 1992).

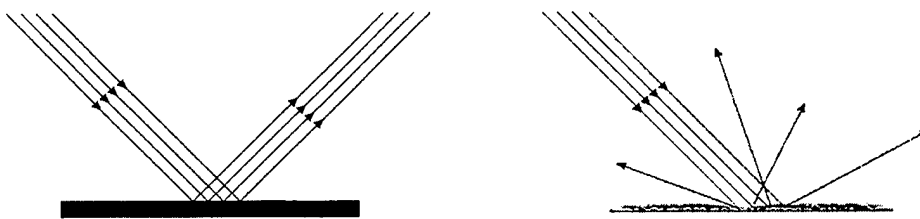

Figure 6. Specular (left) and diffuse (right) reflection.

When these reflections result in backscatter anywhere within an optical/EO system, measurement errors and noise become undesirable consequences. The following section describes a novel aperture design that uses the same law of reflection to reduce backscatter in the direction(s) of the optical channel. This significantly reduces the need for the aperture standoff requirement, allowing optical/EO systems to become more compact without the previous costs in error and noise.

## Aperture design

In the discussion of the problem with current aperture designs above, the law of reflection contributes to the error and noise in optical/EO systems. The proposed new aperture design actually uses the law of reflection to reduce the rays reflected along the optical train, thereby reducing the error and noise. In the simplest version of this new design concept, the aperture is constructed in a "V"-shape. This new design poses no limitations on the possible aperture openings.

For illustrative purposes, Figure 7 depicts a moderately large-sized version of the new V-shaped design with a circular opening. This illustrated implementation of the design shows a rod-mount feature and is an implementation that would be used in optical bench setups, e.g., for test and evaluation, source measurement, etc. This design uses a 45-degree angle. While this is perhaps the optimum angle, any moderate angle size can be used.

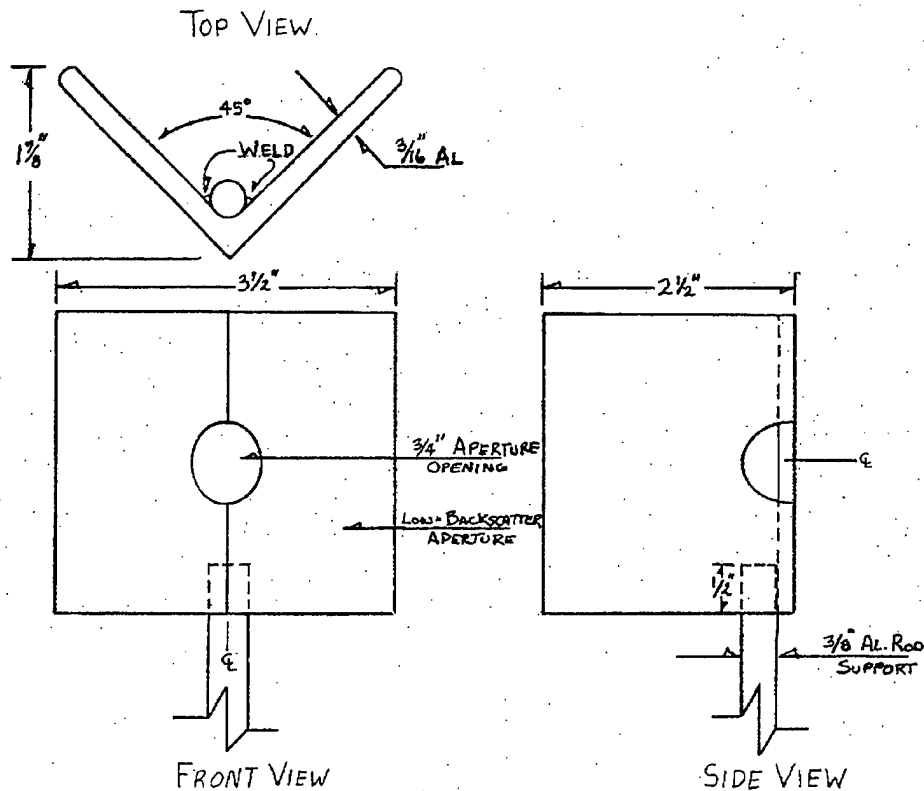

Figure 7. Basic "V"-shaped aperture design showing circular opening.

The V-shape of the low-backscatter aperture design changes the angle of incidence of all rays that do not pass through the aperture opening. The reflected rays will now be reflected at angles that direct them away from the path of the optical train. Figure 8 illustrates this action. When

the aperture is to be used in an enclosed system, the housing enclosure would be appropriately coated to enhance absorption and decrease reflections.

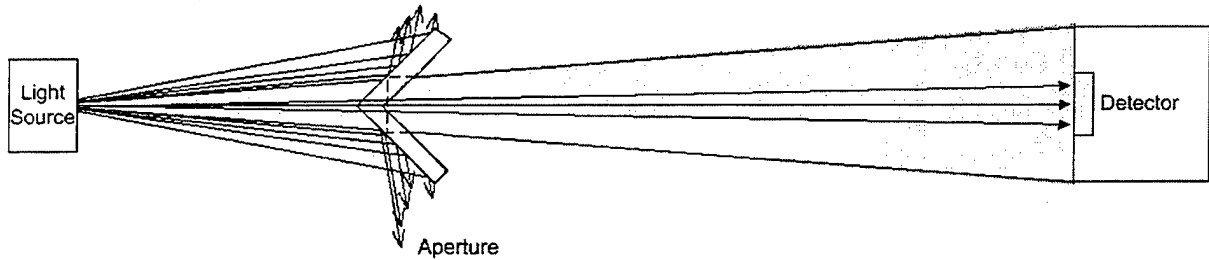

Figure 8. Illustration of the V-shaped low backscatter aperture in operation.

The design implementation depicted in Figures 7 and 8 is geometrically constrained, i.e., asymmetrical. A more robust implementation of the new backscatter design would be a cone-shape aperture (Figure 9). This implementation is symmetrical. Its size would be dictated by its application. Figure 10 shows the operation of this implementation, which by ray tracing is identical to the operation shown for the V-shaped implementation in Figure 8, except that the rays are reflected in a 360-degree pattern.

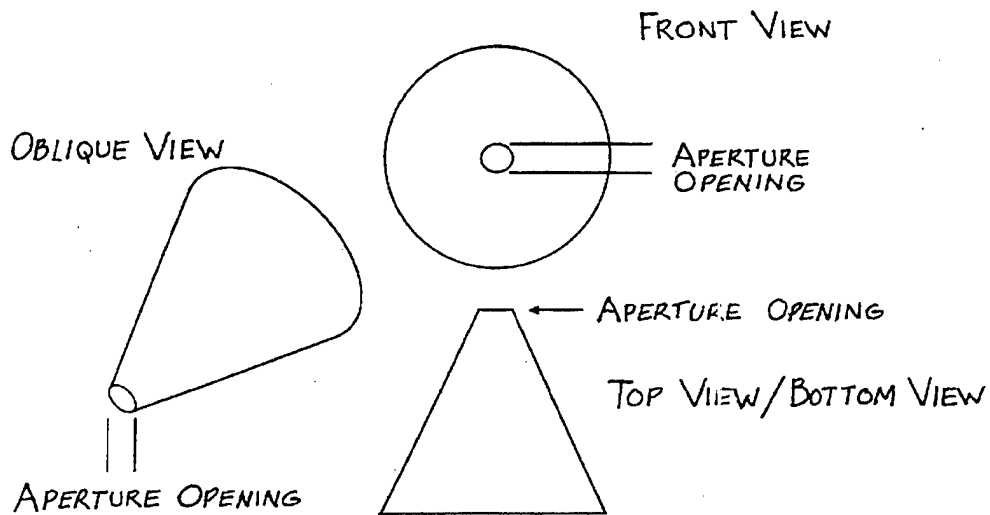

Figure 9. Cone-shaped aperture design showing circular opening.

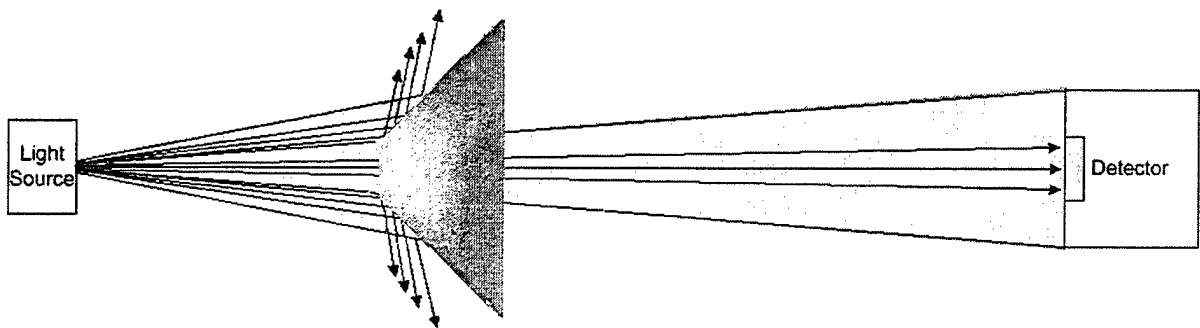

Figure 10. Illustration of the cone-shaped low backscatter aperture in operation.

For miniature optical/EO systems, fixed apertures, i.e., a specific shape and size aperture opening, would be the standard implementation. However, optical bench applications could be more cost effective if the aperture was of such a design as to use replaceable openings. Such a design would consist of a universal base that could accept interchangeable aperture openings of various sizes and shapes. This approach is illustrated in Figure 11, where interchangeable circular and vertical slit openings are shown. Although any number of methods of interchangeability are possible, one using pressure spring clips is depicted in Figure 11.

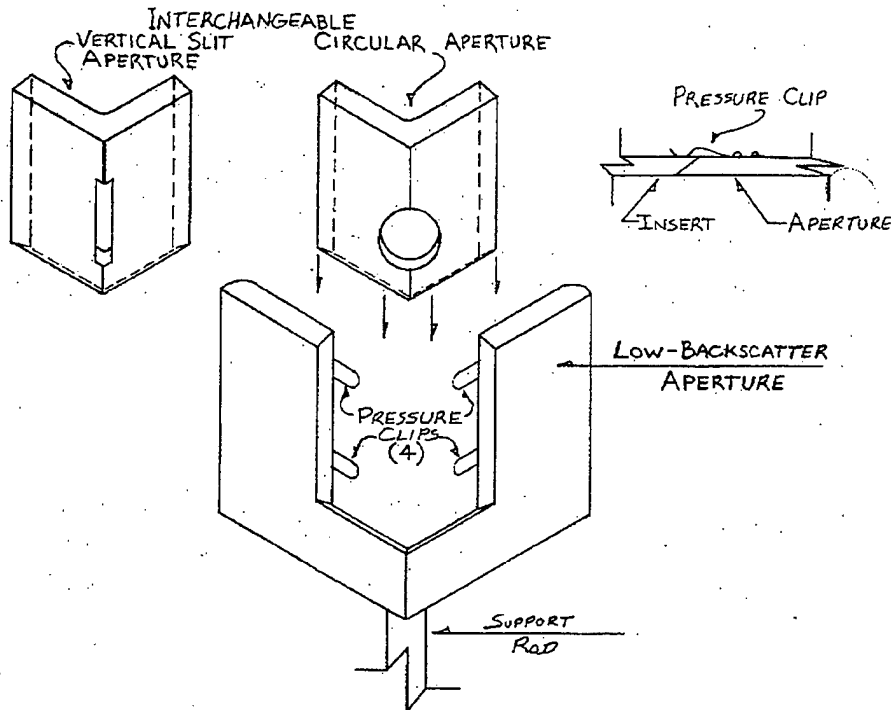

Figure 11. Concept of interchangeable aperture openings.

### Experimental validation

To investigate the validity of the proposed new aperture design, an experimental setup as depicted in Figure 1 for the measurement of a light source was built. The setup consisted of the following: A Gamma Scientific RS-12 regulated tungsten reference lamp, a Photo Research 1980A photometer, a 3-meter optical bench rail, mounting hardware, a conventional flat aperture with a 1-1/2-inch circular opening (Figure 12a), and a custom-fabricated, V-shape, low backscatter aperture, also with a 1-1/2-inch circular opening (Figure 12b-c).

The reference lamp, the aperture under test, and the photometer were mounted on the optical bench rail. The photometer was focused on the front surface of the lamp. The distance between the photometer and the lamp was fixed at 136 centimeters (cm). The initial reading of the lamp was taken in a dark room without an aperture present and measured to be 348.1 footlamberts (FL). After the initial recording, the conventional flat aperture was placed in the optical train and initially placed 1 cm from the front of the lamp. A reading of the light source was made at this position and at subsequent positions in 0.5-cm increments out to a distance of 20 cm from the light source. The conventional flat aperture then was replaced with the low-backscatter aperture, and lamps measurements were repeated at the same positions.

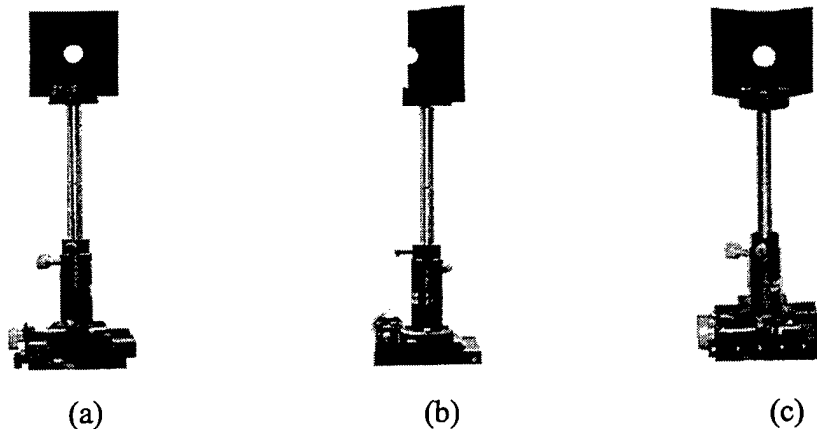

Figure 12. Front view (a) of the conventional flat aperture and side (b) and front (c) views of the low-back scatter aperture used in the concept verification measurements.

The data from these measurements are plotted in Figure 13. Differences in the lamp readings can be noted for the two aperture designs for aperture positions out to approximately 9-10 cm. This lends support to the 10-cm rule-of-thumb cited earlier. These differences also validate the low-backscatter concept design. While this rudimentary validation produced a relatively small, 1.27 percent, reduction in the lamp measurement error in this macro application, this error difference was as large as 4.5 FL.

Another observation is that the fabricated example of the low-backscatter aperture tested here did not completely eliminate the backscatter. While this residual effect was expected (hence the “low-backscatter” nomenclature), it could be reduced further with a better “black” absorbing matte coating on the aperture and a more finely honed ridge on the front of the “V” edge of the aperture.

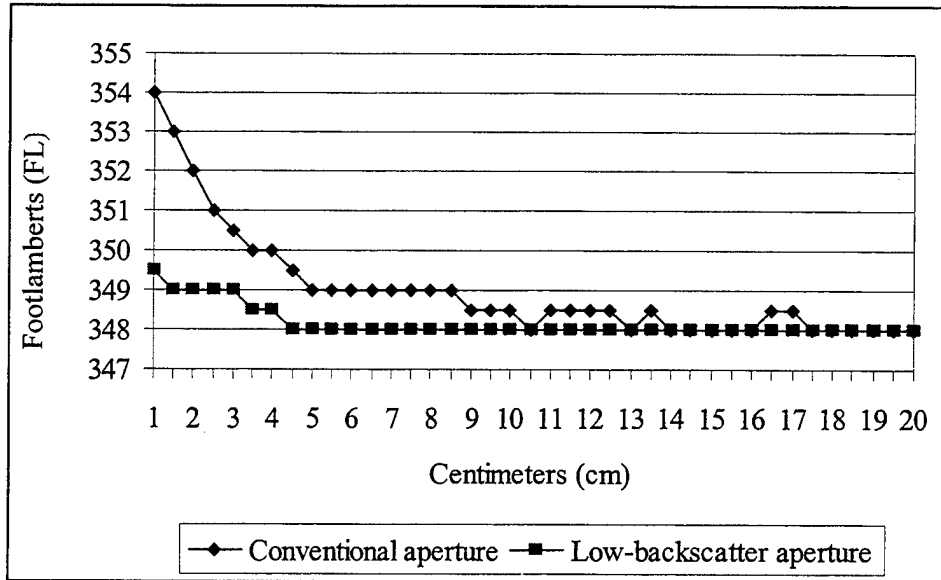

Figure 13. Comparison of lamp readings as a function of aperture distance for conventional and low-backscatter designs.

### Summary

Conventional flat aperture designs introduce error and noise in optical/EO applications when the aperture is placed in close proximity to a light source located within the system. Rays that are reflected off the blocked portion of the aperture and then are reflected again off of the light source and reenter the optical path introduce this error. A novel design for a low-backscatter aperture has been introduced and validated for a light measurement application. The new concept is predicated on a V- or cone-shaped aperture design that uses the law of reflection to direct blocked light rays away from the optical path. A light source application was used to validate the new design.

## References

- Beiser, A. 1992. Physics. New York: Addison-Welsey.
- DeCusatis, C. 1997. Handbook of applied photometry. Woodbury, NY: AIP Press.
- Glassresource.com. September 2001. <http://www.glassresource.com/sub/mirror/mirrhist.htm>,
- Ohno, Y. 1997. Photometric standards. In (C. DeCusatis) Handbook of Applied Photometry. 134.
- Ryer, A. 1997. Light measurement handbook. Newburyport, MA: International Light, Inc.
- Walker, B. H. 1998. Optical engineering fundamentals. Bellingham, WA:SPIE Optical Engineering Press.
- Winburn, D. C. 1987. What every engineer should know about lasers. New York: Marcek Dekker, Inc.