

NATIONAL TRANSPORTATION SAFETY BOARD

WASHINGTON, D.C. 20594

AIRCRAFT ACCIDENT REPORT

RUNWAY OVERRUN DURING LANDING
AMERICAN AIRLINES FLIGHT 1420
MCDONNELL DOUGLAS MD-82, N215AA
LITTLE ROCK, ARKANSAS
JUNE 1, 1999

DISTRIBUTION STATEMENT A
Approved for Public Release
Distribution Unlimited

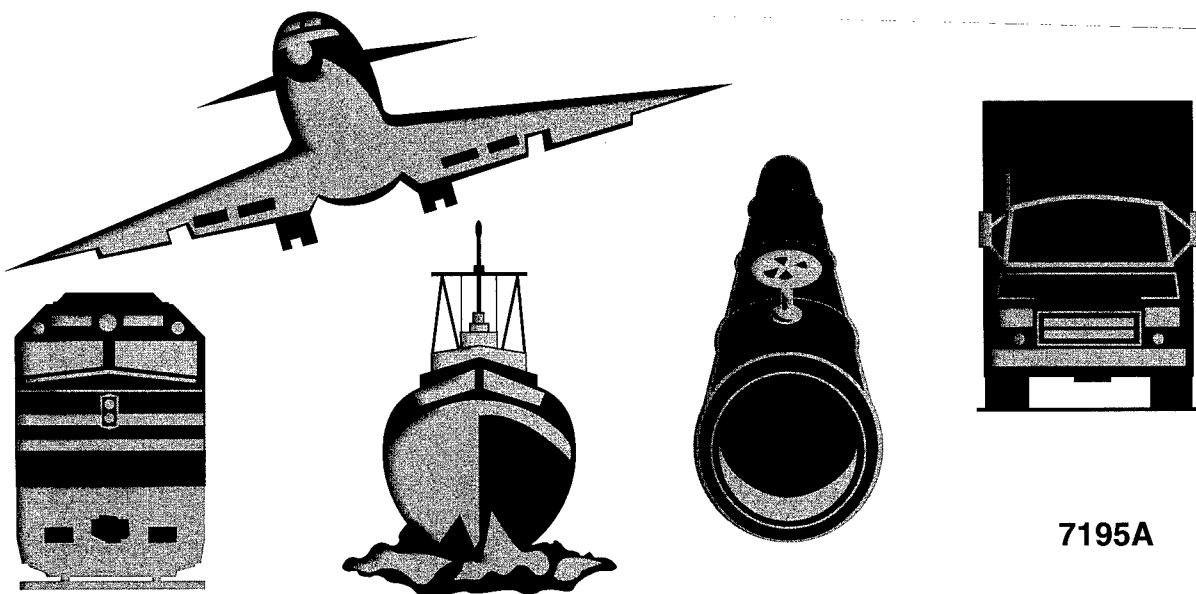

7195A

20020114 016

Aircraft Accident Report

**Runway Overrun During Landing
American Airlines Flight 1420
McDonnell Douglas MD-82, N215AA
Little Rock, Arkansas
June 1, 1999**

**NTSB/AAR-01/02
PB2001-910402
Notation 7195A
Adopted October 23, 2001**



**National Transportation Safety Board
490 L'Enfant Plaza, S.W.
Washington, D.C. 20594**

National Transportation Safety Board. 2001. *Runway Overrun During Landing, American Airlines Flight 1420, McDonnell Douglas MD-82, N215AA, Little Rock, Arkansas, June 1, 1999. Aircraft Accident Report NTSB/AAR-01/02.* Washington, DC.

Abstract: This report explains the accident involving American Airlines flight 1420, a McDonnell Douglas MD-82, which crashed after it overran the end of runway 4R during landing at Little Rock National Airport in Little Rock, Arkansas. Safety issues discussed in this report focus on flight crew performance, flight crew decision-making regarding operations in adverse weather, pilot fatigue, weather information dissemination, emergency response, fragility of airport structures, and Federal Aviation Administration (FAA) oversight. Safety recommendations concerning these issues are addressed to the FAA and the National Weather Service.

The National Transportation Safety Board is an independent Federal agency dedicated to promoting aviation, railroad, highway, marine, pipeline, and hazardous materials safety. Established in 1967, the agency is mandated by Congress through the Independent Safety Board Act of 1974 to investigate transportation accidents, determine the probable causes of the accidents, issue safety recommendations, study transportation safety issues, and evaluate the safety effectiveness of government agencies involved in transportation. The Safety Board makes public its actions and decisions through accident reports, safety studies, special investigation reports, safety recommendations, and statistical reviews.

Recent publications are available in their entirety on the Web at <<http://www.nts.gov>>. Other information about available publications also may be obtained from the Web site or by contacting:

**National Transportation Safety Board
Public Inquiries Section, RE-51
490 L'Enfant Plaza, S.W.
Washington, D.C. 20594
(800) 877-6799 or (202) 314-6551**

Safety Board publications may be purchased, by individual copy or by subscription, from the National Technical Information Service. To purchase this publication, order report number **PB2001-910402** from:

**National Technical Information Service
5285 Port Royal Road
Springfield, Virginia 22161
(800) 553-6847 or (703) 605-6000**

The Independent Safety Board Act, as codified at 49 U.S.C. Section 1154(b), precludes the admission into evidence or use of Board reports related to an incident or accident in a civil action for damages resulting from a matter mentioned in the report.

Contents

Abbreviations	ix
Executive Summary	xii
1. Factual Information	1
1.1 History of Flight	1
1.2 Injuries to Persons	8
1.3 Damage to Airplane	9
1.4 Other Damage	9
1.5 Personnel Information	9
1.5.1 The Captain	9
1.5.2 The First Officer	10
1.5.3 The Flight Attendants	11
1.6 Airplane Information	12
1.6.1 Maintenance Records	13
1.6.2 Spoiler System Information	15
1.6.2.1 Testimony on Spoiler System Operation	19
1.6.2.2 Other Spoiler Events	20
1.6.3 Braking System Information	21
1.6.4 Weight and Balance	22
1.6.5 N215AA's Previous Flights on the Day of the Accident	22
1.6.6 MD-80 Demonstrated Landing Distance	23
1.7 Meteorological Information	23
1.7.1 Airport Weather Information	23
1.7.2 National Weather Service Information	26
1.7.3 American Airlines Weather Information	31
1.7.4 Additional Weather Information	33
1.7.4.1 Lightning Data	33
1.7.4.2 Witness Statements	33
1.7.4.3 Windshear Hazard Study	33
1.8 Aids to Navigation	34
1.9 Communications	34
1.10 Airport Information	34
1.10.1 Runway 4R/22L Safety Areas	36
1.10.2 Runway 22L Approach Lighting System Support Structure	37
1.10.3 Runway 4R Assessments	38
1.10.3.1 Tire Marks	38
1.10.3.2 Runway Surface Information	39
1.10.4 Air Traffic Control Tower Information	40
1.11 Flight Recorders	42
1.11.1 Cockpit Voice Recorder	42
1.11.2 Flight Data Recorder	42
1.12 Wreckage and Impact Information	43
1.12.1 General Wreckage Description	43

1.12.2 Spoiler System	46
1.12.3 Engines	46
1.12.4 Landing Gear and Brake Assemblies	46
1.13 Medical and Pathological Information	47
1.14 Fire	48
1.15 Survival Aspects	48
1.15.1 General	48
1.15.2 Evacuation of Passengers and Crewmembers	50
1.15.3 Emergency Response	51
1.15.4 Passenger Statements	54
1.16 Tests and Research	55
1.16.1 Spoiler System Ground Tests	55
1.16.1.1 Testing Conducted After the Palm Springs Incident	56
1.16.2 Main Landing Gear Tire Examination	57
1.16.3 Cockpit Voice Recorder Sound Spectrum Study	58
1.16.4 Airplane Performance Study	59
1.16.4.1 Calculated Ground Trajectory	60
1.16.4.2 Ground Deceleration Study	61
1.16.5 Engineered Materials Arresting System Computer Model	63
1.17 Organizational and Management Information	64
1.17.1 Aviation Safety Action Program	66
1.17.2 Flight Crew Training	67
1.17.2.1 Simulator Flight Training	68
1.17.2.2 Observations of Simulator Sessions	69
1.17.2.3 Human Factors and Safety Training	70
1.17.3 Approach Procedures	71
1.17.3.1 Approach Briefing	71
1.17.3.2 Before Landing Checklist	71
1.17.3.2.1 Manufacturer's Information	72
1.17.3.3 Crew Coordination Procedures	73
1.17.3.4 Stabilized Approach Concept	74
1.17.3.4.1 Federal Aviation Administration Guidance	75
1.17.3.5 Thunderstorm and Windshear Avoidance	76
1.17.3.6 Continuation of an Approach Below the Decision Height	77
1.17.3.7 Missed Approach Policy	78
1.17.4 Landing Procedures	79
1.17.4.1 Wind Landing Limits	79
1.17.4.1.1 Manufacturer's Information	79
1.17.4.2 Spoiler Deployment Procedures	80
1.17.4.2.1 Manufacturer's Information	80
1.17.4.3 Braking Procedures	80
1.17.4.3.1 Manufacturer's Information	81
1.17.4.4 Use of Reverse Thrust	82
1.17.4.4.1 Manufacturer's Information	82
1.17.4.4.2 MD-80 All Operators Letter	83
1.17.5 Postaccident Actions	84
1.17.5.1 DC-9 Operating Manual Changes	86
1.17.5.2 Flight Manual Changes	88
1.17.6 Federal Aviation Administration Oversight	89
1.17.6.1 Principal Operations Inspector	90

1.17.6.2	Aircrew Program Manager	90
1.18	Additional Information	92
1.18.1	Runway Friction Information	92
1.18.2	Study on Thunderstorm Penetration in the Terminal Area	94
1.18.3	Studies on Flight Crew Decision-Making	95
1.18.3.1	Safety Board Study of Flight Crew Involvement in Major Accidents	95
1.18.3.2	National Aeronautics and Space Administration Study on Flight Crew Decision Errors	96
1.18.4	Technologies to Detect and Locate Downed Airplanes	96
1.18.5	Previous Weather-Related Accidents	97
1.18.5.1	Previous Weather-Related Safety Recommendations	98
1.18.6	Previous Fatigue-Related Accidents	102
1.18.6.1	Previous Fatigue-Related Safety Recommendation	103
1.18.6.2	Additional Fatigue Information	105
1.18.7	Other Previous Related Accidents	106
1.18.7.1	Accidents Involving Rescue Efforts	106
1.18.7.2	Accidents Involving Delayed Emergency Response	108
1.18.8	Other Previous Related Safety Recommendations	109
1.18.8.1	Aircraft Operations in the Airport Environment	109
1.18.8.2	Stabilized Approach Guidance	110
1.18.8.3	Manufacturer's Operating Information	111
2.	Analysis	113
2.1	General	113
2.2	Accident Scenario	113
2.2.1	The Approach	113
2.2.1.1	Descent Into the Terminal Area	114
2.2.1.2	Maneuvering to the Airport for Final Approach	115
2.2.1.3	Final Approach Segment	121
2.2.1.4	Summary of the Flight Crew's Performance During the Approach	126
2.2.2	The Landing	128
2.2.2.1	Lack of Spoiler Deployment	129
2.2.2.1.1	Autospoiler Arming	130
2.2.2.1.2	Checklist Design Regarding Spoiler Arming	132
2.2.2.1.3	Manual Spoiler Deployment	133
2.2.2.2	Use of Reverse Thrust Above 1.3 Engine Pressure Ratio	135
2.2.2.3	Use of Manual Braking	137
2.2.2.4	Summary of the Landing	139
2.2.3	Human Factors	140
2.2.3.1	The Role of Situational Stress	141
2.2.3.1.1	Industry Standards and Practices	141
2.2.3.2	The Role of Fatigue	143
2.3	Meteorological Support	146
2.3.1	Weather Information Provided by the Local Controller	146
2.3.1.1	Weather Information Depiction on Air Traffic Control Radar Systems	147
2.3.2	Additional En Route Weather Information	148
2.3.2.1	Dispatch Office Weather Radar	148
2.3.2.2	Center Weather Service Unit Staffing	149
2.3.2.3	Automated Surface Observing System Lockout Period	149
2.3.3	Airport Weather Equipment	150

2.3.3.1	Runway Visual Range System	150
2.3.3.2	Low Level Windshear Alert System	151
2.4	Emergency Response	152
2.4.1	Aircraft Rescue and Fire Fighting Staffing Levels	154
2.4.2	Crash Detection and Location Technology	155
2.4.3	Interagency Emergency Response Critique	156
2.5	Airport Factors	158
2.5.1	Runway Safety Areas	158
2.5.2	Nonfrangible Structures	159
2.6	American Airlines	160
2.6.1	Stabilized Approach Criteria	160
2.6.2	Spoiler System Training	162
2.6.3	Spoiler and Braking Systems Procedures	163
2.7	Federal Aviation Administration Oversight	165
3.	Conclusions	167
3.1	Findings	167
3.2	Probable Cause	169
4.	Recommendations	171
5.	Appendixes	175
A:	Investigation and Hearing	175
B:	Cockpit Voice Recorder Transcript	176
C:	Automated Surface Observing System Data	215

Figures

1. Flight 1420's Approach Path to the Airport and Key CVR Comments	7
2. Spoiler Control System	17
3. Spoiler Hydraulic System	17
4. Spoiler Handle in the Unarmed Position.	18
5. Spoiler Handle in the Armed Position.	18
6. Position of the Crank Arm and Roller With the Spoiler Handle in the Unarmed and Armed Positions (View From Forward Right to Aft Left)	19
7. 0.4° Base Reflectivity Scan at 2334:27.	28
8. 0.4° Base Reflectivity Scan at 2340:28.	28
9. 0.4° Base Reflectivity Scan at 2345:57.	29
10. 0.4° Base Reflectivity Scan at 2351:59.	30
11. Radial Velocity Image Surrounding the Time of the Accident	30
12. Aerial Photograph of Runway 4R/22L, Airplane Wreckage, and Runway 22L Approach Lighting System	44
13. Airplane Wreckage and Runway 22L Approach Lighting System.	45
14. View of Left Side of Airplane Wreckage and Runway 22L Approach Lighting System	45
15. Interior Airplane Configuration and Occupant Injuries	49
16. Effects of Spoilers, Brakes, and Reverse Thrust on Stopping Distance	62
17. Categories of the Postaccident Audit Recommendations According to Expected Completion Date and Safety Value	85
18. Weather and Flight Information for 2339:12	115
19. Weather and Flight Information for 2339:45	116
20. Weather and Flight Information for 2342:55	117
21. Weather and Flight Information for 2344:30	118

22. Weather and Flight Information for 2345:47	119
23. Weather and Flight Information for 2346:52	120
24. Weather and Flight Information for 2347:08	121
25. Weather and Flight Information for 2349:12	124
26. Weather and Flight Information for 2350:02	125

Abbreviations

AC	advisory circular
ACARS	aircraft communication addressing and reporting system
AD	airworthiness directive
afl	above field level
agl	above ground level
AIM	Aeronautical Information Manual
APM	aircrew program manager
ARFF	aircraft rescue and fire fighting
ARTCC	air route traffic control center
ASAP	American Airlines Safety Action Program
ASOS	Automated Surface Observing System
ASR	Airport Surveillance Radar
ATC	air traffic control
ATCT	air traffic control tower
ATIS	automatic terminal information service
ATOS	Air Transportation Oversight System
CAMI	Civil Aerospace Medical Institute
CFR	<i>Code of Federal Regulations</i>
CVR	cockpit voice recorder
CWSU	center weather service unit
DA	decision altitude
D-BRITE	Digital Bright Radar Indicator Terminal Equipment
dBz	decibel
DEVS	Driver's Enhanced Vision System
DH	decision height
DOT	Department of Transportation

ELT	emergency locator transmitter
EMAS	Engineered Materials Arresting System
EPR	engine pressure ratio
FAA	Federal Aviation Administration
FCOM	flight crew operating manual
FDR	flight data recorder
fpm	feet per minute
GPWS	ground proximity warning system
HBAT	Flight Standards Handbook Bulletin for Air Transportation
Hg	mercury
HIWAS	Hazardous In-flight Weather Advisory Service
Hz	hertz
IFR	instrument flight rules
ILS	instrument landing system
IOE	initial operating experience
LLWAS	Low Level Windshear Alert System
LOFT	line-oriented flight training
MDA	minimum descent altitude
MEL	minimum equipment list
MEMS	Metropolitan Emergency Medical Services
METAR	meteorological aerodrome report
mHz	megahertz
msl	mean sea level
NASA	National Aeronautics and Space Administration
nm	nautical mile
NPRM	notice of proposed rulemaking
NWS	National Weather Service
POI	principal operations inspector
psi	pounds per square inch

PTRS	Program Tracking and Reporting System
RVR	runway visual range
SDR	service difficulty report
SIGMEC	significant meteorological condition
SIGMET	significant meteorological information
SPECI	special weather observation
TAF	terminal aerodrome forecast
TDWR	Terminal Doppler Weather Radar
TRACON	terminal radar approach control
TSA	time since awakening
UTC	coordinated universal time
V_{ref}	reference airspeed for landing
VFR	visual flight rules
VOR	very high frequency omnidirectional radio range
WSP	Weather Systems Processor
WSR-88D	Weather Surveillance Radar 1988 Doppler system

Executive Summary

On June 1, 1999, at 2350:44 central daylight time, American Airlines flight 1420, a McDonnell Douglas DC-9-82 (MD-82), N215AA, crashed after it overran the end of runway 4R during landing at Little Rock National Airport in Little Rock, Arkansas. Flight 1420 departed from Dallas/Fort Worth International Airport, Texas, about 2240 with 2 flight crewmembers, 4 flight attendants, and 139 passengers aboard and touched down in Little Rock at 2350:20. After departing the end of the runway, the airplane struck several tubes extending outward from the left edge of the instrument landing system localizer array, located 411 feet beyond the end of the runway; passed through a chain link security fence and over a rock embankment to a flood plain, located approximately 15 feet below the runway elevation; and collided with the structure supporting the runway 22L approach lighting system. The captain and 10 passengers were killed; the first officer, the flight attendants, and 105 passengers received serious or minor injuries; and 24 passengers were not injured. The airplane was destroyed by impact forces and a postcrash fire. Flight 1420 was operating under the provisions of 14 *Code of Federal Regulations* Part 121 on an instrument flight rules flight plan.

The National Transportation Safety Board determines that the probable causes of this accident were the flight crew's failure to discontinue the approach when severe thunderstorms and their associated hazards to flight operations had moved into the airport area and the crew's failure to ensure that the spoilers had extended after touchdown. Contributing to the accident were the flight crew's (1) impaired performance resulting from fatigue and the situational stress associated with the intent to land under the circumstances, (2) continuation of the approach to a landing when the company's maximum crosswind component was exceeded, and (3) use of reverse thrust greater than 1.3 engine pressure ratio after landing.

The safety issues in this report focus on flight crew performance, flight crew decision-making regarding operations in adverse weather, pilot fatigue, weather information dissemination, emergency response, fragility of airport structures, and Federal Aviation Administration (FAA) oversight. Safety recommendations concerning these issues are addressed to the FAA and the National Weather Service.

1. Factual Information

1.1 History of Flight

On June 1, 1999, at 2350:44 central daylight time,¹ American Airlines flight 1420, a McDonnell Douglas DC-9-82 (MD-82), N215AA, crashed after it overran the end of runway 4R during landing at Little Rock National Airport in Little Rock, Arkansas. Flight 1420 departed from Dallas/Fort Worth International Airport, Texas, about 2240 with 2 flight crewmembers, 4 flight attendants, and 139 passengers aboard and touched down in Little Rock at 2350:20. After departing the end of the runway, the airplane struck several tubes extending outward from the left edge of the instrument landing system (ILS) localizer array, located 411 feet beyond the end of the runway; passed through a chain link security fence and over a rock embankment to a flood plain, located approximately 15 feet below the runway elevation; and collided with the structure supporting the runway 22L approach lighting system. The captain and 10 passengers were killed; the first officer, the flight attendants, and 105 passengers received serious or minor injuries; and 24 passengers were not injured.² The airplane was destroyed by impact forces and a postcrash fire. Flight 1420 was operating under the provisions of 14 *Code of Federal Regulations* (CFR) Part 121 on an instrument flight rules (IFR) flight plan.

Flight 1420 was the third and final leg of the first day of a 3-day sequence for the flight crew. The flight sequence began at O'Hare International Airport, Chicago, Illinois. According to American Airlines company records, the captain checked in for the flight about 1038, and the first officer checked in about 1018. Flight 1226, from Chicago to Salt Lake City International Airport, Utah, departed about 1143 and arrived about 1458 (1358 mountain daylight time). Flight 2080, from Salt Lake City to Dallas/Fort Worth, departed about 1647 (1547 mountain daylight time) and arrived about 2010, 39 minutes later than scheduled because of an airborne hold during the approach resulting from adverse weather in the airport area. The captain was the flying pilot for flight 1226, and the first officer was the flying pilot for flight 2080.

Flight 1420, from Dallas/Fort Worth to Little Rock, was scheduled to depart about 2028 and arrive about 2141. However, before its arrival at Dallas/Fort Worth, the flight crew received an aircraft communication addressing and reporting system (ACARS)³ message indicating a delayed departure time of 2100 for flight 1420. After deplaning from flight 2080, the flight crew proceeded to the departure gate for flight 1420. The flight crew then received trip paperwork for the flight, which included an American Airlines weather advisory for a widely scattered area of thunderstorms along the planned route and two

¹Unless otherwise indicated, all times in this report are central daylight time, based on a 24-hour clock.

² See section 1.2 for an injury chart.

³ ACARS is a data link system that, among other things, enables airline dispatchers and flight crews to communicate via text messages while an airplane is in flight.

National Weather Service (NWS) in-flight weather advisories for an area of severe thunderstorms⁴ along the planned route.⁵

The airplane originally intended to be used for the flight was delayed in its arrival to Dallas/Fort Worth because of the adverse weather in the area. After 2100, the first officer notified gate agents that flight 1420 would need to depart by 2316 because of American's company duty time limitation.⁶ The first officer then telephoned the flight dispatcher to suggest that he get another airplane for the flight or cancel it.⁷ Afterward, the accident airplane, N215AA, was substituted for flight 1420. The flight's 2240 departure time was 2 hours 12 minutes later than the scheduled departure time. The captain was the flying pilot, and the first officer was the nonflying pilot.

About 2254, the flight dispatcher sent the flight crew an ACARS message indicating that the weather around Little Rock might be a factor during the arrival. The dispatcher suggested that the flight crew expedite the arrival to beat the thunderstorms if possible, and the flight crew acknowledged this message. The first officer indicated, in a postaccident interview, that "there was no discussion of delaying or diverting the landing" because of the weather. According to the predeparture trip paperwork, two alternate airports—Nashville International Airport, Tennessee, and Dallas/Fort Worth—were specified as options in case a diversion was needed.

Beginning about 2258, flight 1420 was handled by controllers from the Fort Worth Air Route Traffic Control Center (ARTCC). About 2304, the Fort Worth center broadcast NWS Convective SIGMET [significant meteorological information] weather advisory 15C for an area of severe thunderstorms that included the Little Rock airport area. The cockpit voice recorder (CVR) indicated that the flight crew had discussed the weather and the need to expedite the approach. At 2325:47, the captain stated, "we got to get over there quick." About 5 seconds later, the first officer said, "I don't like that...that's lightning," to which the captain replied, "sure is." The CVR also indicated that the flight crew had the city of Little Rock and the airport area in sight by at 2326:59.

About 2327, the Fort Worth center cleared the flight to descend to 10,000 feet mean sea level (msl) and provided an altimeter setting of 29.86 inches of mercury (Hg). The flight was transferred about 2328 to the Memphis ARTCC, which provided the same altimeter setting.⁸

⁴ A severe thunderstorm has winds measuring 50 knots (58 mph) or greater, 3/4-inch or larger hail, or tornadoes and can produce torrential rain and frequent lightning.

⁵ See section 1.7 for specific details on weather advisories discussed in this section.

⁶ American Airlines' maximum pilot duty time (by contractual agreement with the Allied Pilots Association) is 14 hours from the scheduled time of check-in for the first flight leg to the time that the last flight leg is scheduled to land.

⁷ The flight dispatcher stated that he received the first officer's call between 2150 and 2200.

⁸ The Center Weather Service Unit (CWSU) of the Memphis center was staffed for 16-hour operation and had closed about 2130.

According to the CVR, the flight crew contacted the Little Rock Air Traffic Control Tower (ATCT) at 2334:05. The controller advised the flight crew that a thunderstorm located northwest of the airport was moving through the area and that the wind was 280° at 28 knots gusting to 44 knots. The first officer told the controller that he and the captain could see the lightning. The controller told the flight crew to expect an ILS approach to runway 22L.⁹ The first officer indicated in a postaccident interview that, during the descent into the terminal area, the weather appeared to be about 15 miles away from the airport and that he and the captain thought that there was “some time” to make the approach.

The CVR indicated that, between at 2336:04 and at 2336:13, the captain and first officer discussed American Airlines’ crosswind limitation for landing. The captain indicated that 30 knots was the crosswind limitation but realized that he had provided the limitation for a dry runway. The captain then stated that the wet runway crosswind limitation was 20 knots, but the first officer stated that the limitation was 25 knots. In testimony at the National Transportation Safety Board’s public hearing on this accident,¹⁰ the first officer stated that neither he nor the captain checked the actual crosswind limitation in American’s flight manual. The first officer testified that he had taken the manual out but that the captain had signaled him to put the manual away because the captain was confident that the crosswind limitation was 20 knots.¹¹

At 2339:00, the controller cleared the flight to descend to an altitude of 3,000 feet msl. The controller then asked the flight crew about the weather conditions along the runway 22L final approach course, stating his belief that the airplane’s weather radar was “a lot better” than the weather radar depiction available in the tower. At 2339:12, the first officer stated, “okay, we can...see the airport from here. We can barely make it out but we should be able to make [runway] two two...that storm is moving this way like your radar says it is but a little bit farther off than you thought.” The controller then offered flight 1420 a visual approach to the runway, but the first officer indicated, “at this point, we really can’t make it out. We’re gonna have to stay with you as long as possible.”

At 2339:45, the controller notified flight 1420 of a windshear alert,¹² reporting that the centerfield wind was 340° at 10 knots, the north boundary wind was 330° at 25 knots,

⁹ The ILS is a precision approach system consisting of a localizer and a glideslope, which provide lateral and vertical guidance, respectively, to a runway. The system uses ground-based radio transmitters that provide both the localizer and the glideslope signals.

¹⁰ The Safety Board held a public hearing on this accident from January 26 to 28, 2000, in Little Rock (see appendix A). The Board may hold a public hearing as part of its investigation into an accident to supplement the factual record of the investigation. The Board calls technical experts and material witnesses to testify, and Board investigative staff and designated representatives from the parties to the investigation ask questions to obtain additional factual information. The hearing is not intended to analyze factual information for cause.

¹¹ The captain correctly indicated that 20 knots was the crosswind limitation for landing on a wet runway. See section 1.17.4.1 for additional information on American’s crosswind limitations.

¹² Windshear is generally defined as a change in wind direction and/or speed over a short distance. Windshear alerts for Little Rock airport are issued by a Low Level Windshear Alert System (LLWAS), which is explained in section 1.7.1.

and the northwest boundary wind was 010° at 15 knots. The flight crew then requested runway 4R so that there would be a headwind, rather than a tailwind, during landing. At 2340:20, the controller instructed the flight crew to fly a heading of 250° for vectors to the runway 4R ILS final approach course. After reaching the assigned heading, the airplane was turned away from the airport and clear of the thunderstorm that had previously been reported by the controller. The CVR indicated that, between 2340:46 and 2341:31, the first officer stated the localizer frequency and course, the decision altitude, the minimum safe altitude, and a portion of the missed approach procedure for runway 4R.

Between 2342:19 and 2342:24, the CVR indicated that the captain asked the first officer, “do you have the airport? Is that it right there? I don’t see a runway.” At 2342:27, the controller told the flight crew that the second part of the thunderstorm was apparently moving through the area and that the winds were 340° at 16 knots gusting to 34 knots. At 2342:40, the first officer asked the captain whether he wanted to accept “a short approach” and “keep it in tight.” The captain answered, “yeah, if you see the runway. ‘cause I don’t quite see it.” The first officer stated, “yeah, it’s right here, see it?” The captain replied, “you just point me in the right direction and I’ll start slowing down here.” At 2342:55, the first officer said, “it’s going right over the...field.” At 2342:59, the first officer told the controller, “well we got the airport. We’re going between clouds. I think it’s right off my, uh, three o’clock low, about four miles.” The controller then offered a visual approach for runway 4R, and the first officer accepted. At 2343:11, the controller cleared flight 1420 for a visual approach to runway 4R and indicated “if you lose it, need some help, let me know please.”

At 2343:35, the first officer stated, “you’re comin’ in. There’s the airport.” Three seconds later, the captain stated, “uh, I lost it,” to which the first officer replied, “see it’s right there.” The captain then stated, “I still don’t see it...just vector me. I don’t know.” At 2343:59, the controller cleared flight 1420 to land and indicated that the winds were 330° at 21 knots. At 2344:19, the captain stated, “see we’re losing it. I don’t think we can maintain visual.” At 2344:30, the first officer informed the controller that visual contact with the airport had been lost because of a cloud between the airplane and the airport. The controller then cleared the airplane to fly a heading of 220° for radar vectors for the ILS approach to runway 4R and directed the flight to descend to and maintain 2,300 feet msl. At 2345:47, the first officer told the controller “we’re getting pretty close to this storm. we’ll keep it tight if we have to.” The controller indicated to the flight crew that, “when you join the final, you’re going to be right at just a little bit outside the marker if that’s gonna be okay for ya.” The captain stated, “that’s great,” and the first officer told the controller, “that’s great with us.” At 2346:39, the controller advised the flight crew that the airplane was 3 miles from the outer marker.¹³

¹³ The outer marker is located 5.9 miles from the airport. In a postaccident interview, the first officer stated that, at this point, there was urgency to land because the weather was “up against” the airport.

At 2346:52, the captain stated, "aw, we're goin' right into this." At the same time, the controller reported that there was heavy rain at the airport, the automatic terminal information service (ATIS) information in effect at the time was no longer current,¹⁴ the visibility was less than 1 mile, and the runway visual range (RVR)¹⁵ for runway 4R was 3,000 feet. The first officer acknowledged this information. At 2347:08, the controller again cleared flight 1420 to land and indicated that the wind was 350° at 30 knots gusting to 45 knots. The first officer then read back the wind information as 030° at 45 knots. At 2347:22, the captain stated, "three thousand RVR. We can't land on that." Four seconds later, the first officer indicated that the RVR for runway 4R was 2,400 feet, and the captain then said, "okay, fine."¹⁶

At 2347:44, the captain stated, "landing gear down," and the CVR recorded a sound consistent with the landing gear being operated. About 5 seconds later, the captain stated, "and lights please." At 2347:53, the controller issued a second windshear alert for the airport, reporting that the centerfield wind was 350° at 32 knots gusting to 45 knots, the north boundary wind was 310° at 29 knots, and the northeast boundary wind was 320° at 32 knots. This transmission was not acknowledged by the flight crew. At 2348:10, the captain stated, "add twenty [knots]," to which the first officer replied, "right."

At 2348:12, the controller reported that the runway 4R RVR was now 1,600 feet. About 2348:18, the captain indicated that the flight was established on final approach;¹⁷ 6 seconds later, the first officer informed the controller that the flight was established on the inbound portion of the ILS. The controller repeated the clearance to land; stated that the wind was 340° at 31 knots, the north boundary wind was 300° at 26 knots, and the northeast boundary wind was 320° at 25 knots; and repeated the RVR. At 2348:41, the first officer acknowledged this information. The controller did not receive any further transmissions from flight 1420. At 2349:02, the first officer asked the captain, "want forty flaps?" The captain indicated that he thought he had already called for the landing flaps, after which the first officer stated, "forty now." At 2349:10, the controller informed the flight crew that the wind was 330° at 28 knots. Two seconds later, the captain stated, "this is a can of worms."

According to the CVR, the first officer stated, "there's the runway off to your right, got it?" at 2349:24. The captain replied, "no," to which the first officer stated, "I got the

¹⁴ ATIS information Romeo, which was issued about 2326, was based on a 2322 special weather observation indicating (among other things) a thunderstorm with frequent in-cloud and cloud-to-cloud lightning located west through northwest and moving northeast, winds from 190° at 14 knots, a visibility of 7 miles, and an altimeter setting of 29.88 inches of Hg.

¹⁵ RVR is a measurement of the visibility near a runway's surface. This measurement represents the horizontal distance that a pilot should be able to see down a runway from the approach end.

¹⁶ According to the Jeppesen Sanderson approach plate for the ILS approach to runway 4R (dated February 20, 1998), the lowest authorized RVR for that runway was 2,400 feet.

¹⁷ If the weather is reported to be below published minimums, American Airlines and the Federal Aviation Regulations (14 CFR 121.651) allow airplanes that are established on the final approach segment to continue the approach to the appropriate decision height (DH) or minimum descent altitude (MDA) and land in accordance with the conditions for the type of approach being conducted. For this Category I ILS approach, the DH was 200 feet.

runway in sight. You're right on course. Stay where you're at." The captain then stated, "I got it. I got it." At 2349:32, the controller reported the wind to be 330° at 25 knots. At 2349:37, an unidentified voice in the cockpit stated, "wipers," and the CVR then recorded a sound consistent with windshield wiper motion. (This sound continued throughout the rest of the flight.) At 2349:53, the controller reported the wind to be 320° at 23 knots.

The CVR indicated that, at 2349:57, an unidentified voice in the cockpit stated, "aw...we're off course" and that, 1 second later, an unintelligible comment was made by an unidentified voice in the cockpit. In a postaccident interview, the first officer stated that he thought the approach was stabilized until about 400 feet above field level (afl), at which point the airplane drifted to the right. The first officer also stated that he said "go around" about that time but not in a very strong voice. The first officer indicated that he had looked at the captain to see if he had heard him but that the captain was intent on flying and was doing "a good job."

The CVR indicated that, at 2350:00, the first officer said, "we're way off." Flight data recorder (FDR) information indicated that the localizer deviation value was about one dot to the right at that point.¹⁸ About 1 second later, the captain stated, "I can't see it." About 3 seconds afterward, the first officer asked, "got it?" to which the captain replied, "yeah I got it." At 2350:13 and :14, the CVR recorded the sound of the ground proximity warning system (GPWS) radio altitude callout "sink rate."¹⁹ Calculations based on FDR data indicated that the airplane was descending through an altitude of about 70 feet afl at the time of the first sink rate warning and about 50 feet afl at the time of the second warning. Figure 1 shows flight 1420's flightpath to Little Rock and runway 4R along with key CVR comments and the airplane's location when the comments were made.

FDR and CVR data indicated that the airplane touched down on the runway about 2350:20. About 2350:22, the first officer stated "we're down;" about 2 seconds later, he stated, "we're sliding." FDR data also indicated that, over a 7-second period after touchdown, both thrust reversers were deployed and the left and right engines' engine pressure ratios (EPR) reached settings of 1.89 and 1.67, respectively.²⁰ The thrust reversers were subsequently moved to the unlocked status (neither deployed nor stowed).

¹⁸ Cockpit instrumentation shows the airplane's location relative to the glideslope and localizer signals. Displacement is shown in terms of the airplane's angular deviation above or below the glideslope and left or right of the localizer. Pilots can judge the amount of displacement by needle deflections that reference "dots" on the face of the instruments. Because the dots represent an angular measurement of an airplane's deviation from an ILS component, the amount of feet of displacement depends on the airplane's distance from the ILS antennas.

¹⁹ The sink rate alert indicates a rate of descent that exceeds predetermined thresholds.

²⁰ Thrust reversers redirect engine exhaust to help slow an airplane. EPR is a measurement of engine power as a ratio of gases in the exhaust pipe compared with air entering the inlet.

According to the FDR, the flight spoilers did not deploy symmetrically at touchdown,²¹ but a momentary 8° deflection of the left outboard flight spoiler concurrent with a left aileron deflection was recorded.²²

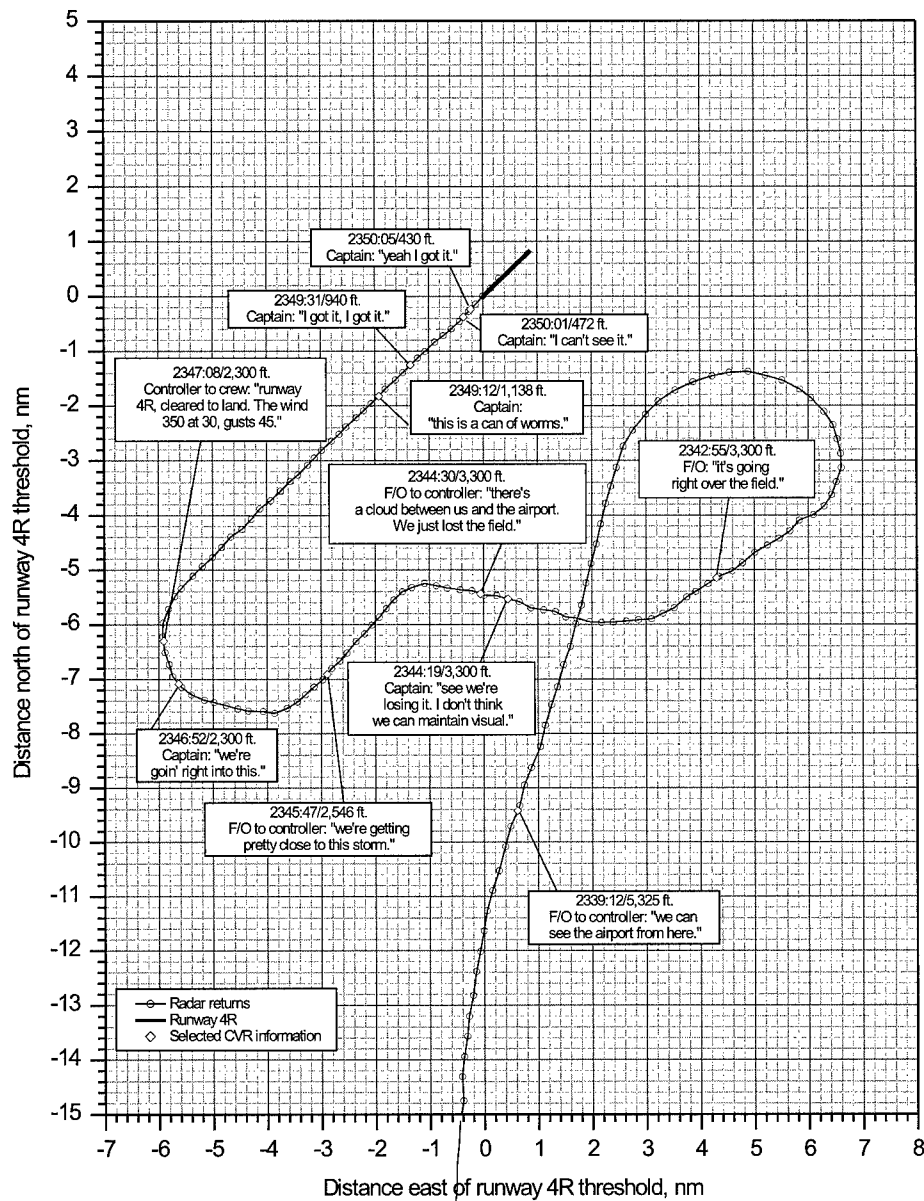

Figure 1. Flight 1420's Approach Path to the Airport and Key CVR Comments

²¹ A spoiler is a device located on an airplane wing's upper surface that, when activated, provides increased drag and decreased lift by disrupting the flow of air over the wing. After touchdown, the spoilers increase the load on the landing gear tires, which is essential for maximizing braking and obtaining the shortest stopping distance.

²² FDR data also showed that the flight spoilers extended symmetrically for 55 seconds, beginning at 2336:42, during the descent into Little Rock.

FDR data indicated that the right and left brake pedals began to move at 2350:25 and :30, respectively, and both pedals reached full travel at 2350:31. About the time that the brakes were applied, the thrust reversers were deployed again. At 2350:32, the CVR recorded an unidentified voice in the cockpit stating “on the brakes.”²³ The left engine reached a maximum setting of 1.98 reverse EPR, and the right engine reached a setting of 1.64 reverse EPR. The left brake pedal was relaxed at 2350:34 before returning to its full position 2 seconds later. About the time that the left brake pedal was relaxed, the reversers were returned to the unlocked status. As the right thrust reverser was being moved to the unlocked status, the right engine reached a maximum setting of 1.74 reverse EPR.

At 2350:36, FDR data indicated a full 60° deployment of the right inboard flight spoiler, concurrent with a full aileron deflection.²⁴ At 2350:40, the left thrust reverser was moved back to the deployed position, but the right reverser moved briefly to the deployed position and then moved to the stowed position. According to FDR data, the left thrust reverser remained deployed, and the right thrust reverser remained stowed, for the remainder of the flight. About 1 second later, the CVR recorded expletives stated by an unidentified voice in the cockpit, which were followed by the sounds of initial impact at 2350:44 and several additional impacts beginning at 2350:47. The CVR stopped recording at 2350:48. The airplane came to rest about 800 feet from the departure end of runway 4R, 34° 44.18 minutes north latitude and 92° 11.97 minutes west longitude. The accident occurred during the hours of darkness.

1.2 Injuries to Persons

Table 1. Injury chart

Injuries	Flight Crew	Cabin Crew	Passengers	Other	Total
Fatal	1	0	10	0	11
Serious	1	3	41	0	45
Minor	0	1	64	0	65
None	0	0	24	0	24
Total	2	4	139	0	145

Note: Title 14 CFR 830.2 defines a serious injury as any injury that (1) requires hospitalization for more than 48 hours, starting within 7 days from the date that the injury was received; (2) results in a fracture of any bone, except simple fractures of fingers, toes, or the nose; (3) causes severe hemorrhages or nerve, muscle, or tendon damage; (4) involves any internal organ; or (5) involves second- or third-degree burns or any burns affecting more than 5 percent of the body surface. A minor injury is any injury that does not qualify as a fatal or serious injury.

²³ In a postaccident interview, the first officer indicated that he did not help with the flight controls until the captain said “brakes” as the airplane was nearing the end of the runway, at which time the first officer helped with the brakes.

²⁴ The FDR recorded only the left aileron position, which indicated a full trailing edge-down deflection at the time.

1.3 Damage to Airplane

According to American Airlines, the damage to the airplane was estimated at \$10.7 million.

1.4 Other Damage

The airplane destroyed several tubes extending outward from the left edge of the runway 4R ILS localizer array, part of a chain link security fence, and approximately 250 feet of the runway 22L approach lighting system support structure and walkway. The damage was estimated at \$325,000.

1.5 Personnel Information

1.5.1 The Captain

The captain, age 48, was hired by American Airlines in July 1979. He held an Airline Transport Pilot certificate and a Federal Aviation Administration (FAA) First Class medical certificate dated February 9, 1999, with no restrictions. The captain was type rated on the Boeing 727 (727) and the MD-80. He qualified as a 727 flight engineer on August 24, 1979; first officer on March 15, 1985; and captain on September 21, 1988. He qualified as an MD-80 captain on July 31, 1991. The captain was also a lieutenant colonel in the U.S. Air Force Reserves.

The captain began his aviation career with the U.S. Air Force in 1972. He flew T-33 and EB-57 airplanes and was a command flight examiner and instructor pilot for the B-57 airplane. He left active military service in 1979 at the rank of captain and began working for American Airlines afterward. The captain was furloughed after 1 year with American but was recalled by the company 3 1/2 years later.²⁵

In July 1998, the captain was promoted to check airman on the MD-80. In a postaccident interview, the MD-80 Fleet Manager stated that the captain was recommended for this position by the Chicago-O'Hare base manager and another check airman because of his technical competence, performance as a line pilot, and ability and desire to instruct. In January 1999, the captain was promoted to chief pilot at the Chicago-O'Hare base.²⁶ The base manager indicated that the captain wanted to be a chief pilot because he had been flying the MD-80 for a long time and wanted a change. The base manager also indicated that the captain was selected for a chief pilot position because of his flying background, company achievements, and leadership skills.

²⁵ During his furlough from American Airlines, the captain worked as a nuclear engineer on submarine propulsion plants.

²⁶ American Airlines policy requires chief pilots to fly 1 month per year as line pilots. The Chicago-O'Hare base manager encouraged chief pilots to fly once a week as line pilots.

The Chicago-O'Hare base manager, who flew with the captain twice in May 1999, said that he was "extremely comfortable flying with the captain" and that the captain had "a great deal of common sense." A first officer who had flown with the captain from Chicago to Dallas/Fort Worth indicated that he was "a knowledgeable pilot who was not intimidating."

American Airlines records indicated that the captain had accumulated 10,234 hours total flying time, including 7,384 hours as a company pilot-in-command (5,518 of which were on the MD-80). His last recurrent ground training and proficiency check occurred on July 19, 1998, and his last line check occurred July 26, 1998. He had flown approximately 54, 46, 14, and 12 hours in the 90, 60, 30, and 7 days, respectively, preceding the accident. FAA records indicated no accident, incident, or enforcement action.

The captain's wife described his activities in the 3 days before the accident as routine, adding that the captain had no scheduled events during that time. She stated that the captain went to sleep about 2200 the night before the accident and slept until between 0700 and 0730. She further stated that, on nonflying days, the captain would typically go to sleep between 2130 and 2200, wake up about 0515, and leave for work about 0600. The captain's wife indicated that he slept later than usual on the morning of the accident because the timing of the first day of the trip did not necessitate an early rising.

The captain's wife indicated that his health was good, he was a nonsmoker, and he consumed a minimal amount of alcohol. At the time of the accident flight, the captain was not taking any prescription drugs. No significant life events occurred in the weeks before the accident, and his finances and personal situation were reported to be stable. Records at the National Driver Register showed no indication of driver's license revocation or suspension for the captain.

The captain and first officer had not flown together before the day of the accident. According to two flight attendants who were working aboard the two legs before the accident flight (flights 1226 and 2080), the captain and first officer seemed to have a good working relationship with each other. The first officer for flight 1420 stated, in a postaccident interview, that the captain had made him feel comfortable in the cockpit. Also, the first officer testified at the public hearing on this accident that his interaction with the captain was not affected by the fact that he was a chief pilot.

1.5.2 The First Officer

The first officer, age 35, was hired by American Airlines in January 1999. He held an Airline Transport Pilot certificate and an FAA First Class medical certificate dated November 12, 1998, with no restrictions. He qualified as a first officer on the MD-80 on February 22, 1999. He was serving a 1-year probation period required of new company hires. The first officer was type rated on the Learjet and the Boeing 737.

The first officer received his private pilot's license in 1983. He began his career in 1988 with the U.S. Navy and completed primary flight training. The first officer had been selected for advanced jet training but was given an honorable discharge in 1991 because of a reduction in force. Before he was hired by American Airlines, the first officer worked as a corporate pilot, flying C-210, Learjet 35, and King Air E-90 airplanes. He was also the director of operations and the chief pilot for an air charter company and a flight instructor.

A captain who flew with the first officer in May 1999 stated that he was an "above average new hire who was very competent and knowledgeable." Another captain who flew with the first officer in May 1999 stated that he was an "experienced pilot with good cockpit discipline."

According to American Airlines records, the first officer had accumulated 4,292 hours of flying time, 182 of which were as a company MD-80 pilot. He had flown approximately 176, 112, 65, and 7 1/2 hours in the 90, 60, 30, and 7 days, respectively, preceding the accident. His proficiency check occurred on February 22, 1999, and his line check occurred on March 10, 1999. FAA records indicated no accident, incident, or enforcement action.

On May 30, 1999, the first officer traveled from his home outside Los Angeles, California, to Chicago. The first officer indicated that he had been commuting from his home to the Chicago-O'Hare base for about 3 months and that, as a result, he was adjusted to the central time zone. The first officer indicated that he was involved in routine activities while in the Chicago area. He went to bed between 2000 and 2200 the night before the accident and woke up about 0730.

The first officer indicated that he was a nonsmoker and that he was not taking any prescription medications at the time of the accident flight. Records at the National Driver Register showed no indication of driver's license revocation or suspension for the first officer.

1.5.3 The Flight Attendants

Flight 1420 was staffed with four flight attendants hired by American Airlines between June 1987 and August 1992. All of the flight attendants were qualified on MD-80 series airplanes. The flight attendants completed the company's initial training, which included instruction in emergency procedures and evacuation drills, and their most recent company recurrent emergency procedures training was completed in either 1998 or 1999.

On the day before the accident flight, three of the flight attendants began the same 3-day trip sequence. On the day of the accident flight, they had worked three trip segments before flight 1420. The fourth flight attendant began a 2-day trip sequence on the day of the accident flight. She had worked two trip segments before flight 1420. Flights 1226 and 2080 (the two legs before the accident flight) were not among the trip segments worked by any of the flight attendants.

1.6 Airplane Information

The MD-80 airplane is a derivative model of the DC-9 airplane. As a result, much of the MD-80's structure and many of its systems, components, and installations are similar to the earlier DC-9 model. According to Boeing,²⁷ the Douglas DC-9 airplane entered service in December 1965; the final DC-9 was delivered in October 1982. The MD-80 airplane's first flight occurred in October 1979. The FAA certified the MD-80 series airplane in August 1980, and the airplane entered service in November 1980. The MD-80 model airplanes—the MD-81, -82, -83, -87, and -88—were in production through 1999. The DC-9 family of airplanes also includes the MD-90 and the Boeing 717.

The accident airplane, N215AA, serial number 49163, was delivered new to American Airlines on August 1, 1983. At the time of the accident, the airplane had accumulated 49,136 flight hours and 27,103 cycles.²⁸ A review of American Airlines' Air Carrier Certificate, which included the standards, terms, conditions, and limitations contained in the FAA-approved Operations Specifications, revealed no discrepancies. The FAA's Type Certificate Data Sheet, which prescribes the conditions and limitations under which airplanes meet airworthiness requirements, noted no discrepancies for DC-9 or MD-80 series airplanes. The FAA's Program Tracking and Reporting System (PTRS)²⁹ indicated no discrepancies for the accident airplane from January 1998 to May 1999.

N215AA was equipped with two Pratt & Whitney JT8D-217C turbofan engines. The No. 1 (left) engine, serial number 718427, was installed on N215AA on September 7, 1997; the No. 2 (right) engine, serial number 725712, was installed on July 30, 1998.

American Airlines' records indicated that, for engine No. 1, the time since new was 29,734 hours (15,711 cycles),³⁰ the time since overhaul was 11,216 hours (5,189 cycles), and the time since installation was 5,256 hours (2,447 cycles). The records also indicated that, for engine No. 2, the time since new was 25,131 hours (13,216 cycles), the time since overhaul was 11,658 hours (5,421 cycles), and the time since installation was 2,618 hours (1,229 cycles).

²⁷ The Boeing Company and McDonnell Douglas Corporation merged in August 1997. Douglas Aircraft Company and McDonnell Aircraft Company merged in April 1967.

²⁸ An airplane cycle is one complete takeoff and landing sequence.

²⁹ The PTRS is an FAA computer tracking system that includes information on inspection and surveillance activities by FAA inspectors. In 1997, the FAA began developing the Air Transportation Oversight System (ATOS) as the FAA's new oversight system and the eventual replacement for PTRS. The Manager of the Flight Standard Division for the FAA's Western Pacific Region, who testified at the Safety Board's public hearing on this accident, stated that ATOS was intended to replace PTRS because that data repository system had reached a plateau and there was no way to make further safety gains with PTRS. Only surveillance data for 10 major U.S. air carriers (including American Airlines) are currently recorded under ATOS; certification activities and data for the 10 carriers are still recorded under PTRS.

³⁰ An engine cycle is one complete startup and shutdown sequence.

The accident airplane was equipped with two AlliedSignal VOR³¹/ILS receivers and an AlliedSignal GPWS computer. The accident airplane was also equipped with a forward-looking X-band airborne weather radar unit that depicted three levels of reflectivity in green, yellow, and red (according to intensity from lightest to heaviest). X-band airborne weather radar systems are subject to attenuation, that is, the scattering or absorption of electromagnetic energy with heavy precipitation. The accident airplane's airborne weather radar did not have attenuation alerts to warn the flight crew of any masking of weather resulting from heavy precipitation, and the radar was not able to detect lightning strikes.

The airborne weather radar had a power output of approximately 125 watts and was integrated with a 30-inch antenna that provided a 3.4° beam width. The radar had a stabilization feature that helped to keep the radar beam steady during turns and pitch changes. The radar had range selections of 10, 20, 40, 80, 160, and 320 miles, a 180° horizontal azimuth display, and a vertical tilt control of $\pm 15^\circ$. In a postaccident interview, the first officer stated that the airborne weather radar was being operated in the 10-, 20-, and 40-nautical mile (nm) ranges and that the tilt was set at the maximum up (+15°) setting. In public hearing testimony, the first officer indicated that he saw only green radar returns depicted on the weather radar unit.

1.6.1 Maintenance Records

American's engineering specification maintenance intervals for MD-82 airplanes include "Periodic Service"; "A," "B," and "C" checks; and "HC" [heavy C] checks. Periodic Service checks are to be accomplished a maximum of 2 flying days from the last periodic service or higher check. A and B checks are to be accomplished every 65 and 470 flight hours, respectively. The first C check is to be accomplished within 5,000 flight hours, and all subsequent C checks are to be accomplished within 4,200 flight hours of the last C check. The first HC check is to be accomplished within 14,000 flight hours, the second one within 12,000 flight hours since the previous HC check or a total time of 24,000 flight hours, and the third and subsequent HC checks within 12,000-flight hour intervals.

The accident airplane's last Periodic Service and A checks were performed on May 31, 1999. All tires and wheels were checked for airworthiness. Tire inflation and brake wear were also checked. No maintenance items were deferred. The last B check was performed on April 21, 1999. All tires and wheels were checked for airworthiness. Tire pressure, flight and ground spoilers, and hydraulic subsystems were also checked. In addition, the requirements of FAA Airworthiness Directive (AD) 98-11-10 were performed. This AD mandated an inspection of the spoiler handle latching lever pin and actions to prevent it from jamming. (According to the AD, a jammed spoiler handle pin can result in retraction of the spoilers and full advancement of the left throttle during a go-around.) The last C check was performed on January 6, 1999, and the last HC check was performed on January 22, 1994.

³¹ VOR stands for very high frequency omnidirectional radio range.

The No. 1 (left) and No. 2 (right) nose gear tire and wheel assemblies were last replaced on May 27 and February 4, 1999, respectively. The No. 1 (outboard) and 2 (inboard) left main landing gear tire and wheel assemblies were last replaced on May 7, 1999. The No. 3 (inboard) and 4 (outboard) right main landing gear tire and wheel assemblies were last replaced on May 15 and April 7, 1999, respectively. The No. 1 and 2 left main landing gear brakes were last replaced on April 3 and April 2, 1999, respectively. The No. 3 and No. 4 right main landing gear brakes were last replaced on December 29, 1998, and April 3, 1999, respectively. No discrepancies were noted after these replacements. All but one of the replacements were nonroutine discrepancies generated from Periodic Service inspections; the No. 1 left nose gear tire and wheel assembly replacement resulted from a pilot report of excessive nose wheel vibration at liftoff.

Discrepancies recorded in American Airlines airplane maintenance logbooks are entered into the company's Field Maintenance Reliability System. Entries from May 15, 1998, to June 1, 1999, in the accident airplane's maintenance logbook were reviewed for discrepancies that referenced flight controls/spoilers, antiskid control, wheels, brakes, rain protection, engine controls, and engine reversing. Also, Field Maintenance Reliability reports, which include descriptions of any mechanical discrepancy, any corrective maintenance actions, and any minimum equipment list (MEL) deferrals, were generated for the accident airplane from June 1, 1998, to May 31, 1999. Selected discrepancies involving autothrottle/speed control, landing, spoilers/drag devices, windows/windshields, brakes, fuselage, engine fuel and control, engine controls, and thrust reversers were reviewed for corrective maintenance actions. No discrepancies were noted.

FAA service difficulty reports (SDR) were reviewed from all DC-9-82 airplane operators regarding the airplane's flight controls/spoilers. Between January 1984 and August 1999, 49 SDRs were submitted regarding flight controls/spoilers; no maintenance trends or discrepancies were found. Also, SDRs for all systems on the accident airplane were reviewed. Between September 1985 and August 1999, 14 SDRs were submitted, but none were relevant to the circumstances of the flight 1420 accident.

In addition, SDRs were reviewed from all DC-9 type-certificated airplanes regarding the airplane's drag control system and drag control actuator. Between January 1995 and October 23, 2001, there were 62 reports regarding the drag control system and 21 reports regarding the drag control actuator, including 13 reports submitted after the flight 1420 accident. Most of the reports were inspection related, false indications, or adjustment or chaffing problems. No maintenance trends or discrepancies were noted; however, one report, which involved a DC-9-32, was noted as being relevant to the circumstances of this accident. Specifically, the discrepancy report stated the following: "Discrepancy: unable to arm ground spoilers on approach, and spoilers did not deploy manually on landing. Corrective Action: Replace spoiler control actuator and spoiler control box. Spoilers adjusted and checked serviceable. Note: the report does not state if the autospoiler 'do not use' light was illuminated."

1.6.2 Spoiler System Information

The MD-80 series airplane has one ground spoiler, one inboard flight spoiler, and one outboard flight spoiler on each wing. Each of the flight spoilers is extended and retracted by its own hydraulic actuator. The left hydraulic system, through the left spoiler bypass valve and a 1,500-pounds per square inch (psi) pressure reducer valve, supplies hydraulic power for the two inboard flight spoiler actuators. The right hydraulic system, through the right spoiler bypass valve and a 1,500-psi pressure reducer valve, supplies hydraulic power for the two outboard flight spoiler actuators.³² Both hydraulic systems supply hydraulic power, through the two ground spoiler control valves, to the two ground spoiler actuators, which are at full system pressure (3,000 psi) and do not have pressure reducer valves. Two position sensors—one mounted on the right inboard flight spoiler panel and the other on the left outboard flight spoiler panel—provide information to the FDR on the position of those spoilers. The FDR records each spoiler position alternately at a sampling rate of two times per second.

The flight spoilers are manually operated through the aileron control system by either the control wheel or the spoiler handle in the cockpit. A control wheel input can supplement lateral control (provided by the ailerons) by extending the flight spoilers on the downward-moving wing to a maximum of 60°. An input from the spoiler handle extends the flight spoilers symmetrically on both wings to a maximum of 35° in flight (referred to as the speed brake function) and a maximum of 60° on the ground. A spring-loaded torsion bar mechanically holds the flight spoilers in the retract position when they are not extended.³³

The ground spoilers are manually operated by an input from the spoiler handle on the cockpit center pedestal and electrical signals from the proximity system electronic unit via several spoiler control relays. The ground spoilers are extended to 60° only during landing or a rejected takeoff. The ground spoilers are locked down by hydraulic power and a mechanical overcenter link during all other phases of flight.

The ground and flight spoilers can be automatically operated by the autospoiler system.³⁴ This system consists of two ground spoiler control valves, the autospoiler switching unit, four wheel spin-up transducers (by way of a ground spoiler control box), and two ground control nose oleo switches. To use the autospoiler system for landing, a pilot raises the spoiler handle up to the ARM position (before touchdown), which reveals a red ARM indicator stripe and positions the roller on the spoiler handle in front of an autospoiler crank arm. (The red indicator stripe provides a visual cue to the flight crew

³² If one of the hydraulic pumps were to fail or was rendered inoperable for maintenance reasons, a power transfer unit would allow the remaining hydraulic system to supply power to the inoperative system. The MD-82 is also equipped with an auxiliary hydraulic pump to power the right hydraulic system on the ground.

³³ The MD-80 can be configured with a spoiler lockout mechanism to prevent in-flight spoiler deployment when the flaps are extended. None of American's MD-80s are configured with the mechanism.

³⁴ MD-80 airplanes can be dispatched with the autospoiler system inoperative. Under that circumstance, the pilot would be required to manually deploy the spoilers upon touchdown.

that the autospoiler system is armed.) When the autospoiler switching unit commands the autospoiler actuator to move the crank arm from the retract to the extend positions, the crank arm pushes the spoiler handle fully aft and extends all of the flight and ground spoilers. After touchdown, the autospoiler switching unit commands the autospoiler actuator to move the crank arm, which in turn moves the spoiler handle fully aft when either the wheel spin-up transducers signal main wheel spin-up or the ground control nose oleo switches signal nose gear touchdown (in case of a failure of the spin-up transducers). The autospoiler system activates the autospoiler actuator on each landing regardless of whether the handle is in the ARM position.

The MD-80 is configured with a spoiler autoretract mechanism that retracts the ground and flight spoilers if the left throttle is advanced above idle (about 1 3/4 to 2 inches). The left throttle arm has a crank that "knocks down," or dislodges, the spoiler handle from the latching mechanism so that the handle return spring can return the spoilers to the stowed position. (The spoiler handle can also be manually dislodged.) The right throttle does not have a crank to knock down the spoiler handle.

An amber AUTO SPOILER DO NOT USE light illuminates on the overhead annunciator panel in the cockpit if the autospoiler system detects certain failures. Specifically, the light will illuminate if (1) the ground spoiler actuator fails to change positions within 10 seconds after being so commanded, (2) the spoiler control relay circuit or the ground spoiler control box circuit has an internal short to ground, (3) only one takeoff or land relay channel is energized, or (4) the two weight-on-wheel sensors (proximity sensors on the main landing gear that indicate when the struts are compressed) and the landing gear handle are inconsistent. If this light appears for one of the first three causes, the flight crew must manually deploy the ground spoilers upon landing. If the light appears for the last cause, the autospoiler actuator will operate as intended as long as it receives normal inputs.

Figures 2 through 6 show the MD-80 spoiler system. Figure 2 shows the spoiler control system, including the locations of the flight and ground spoilers. Figure 3 shows the spoiler hydraulic system. Figures 4 and 5 are photographs showing the location of the spoiler handle in the unarmed and armed positions, respectively. Figure 6 shows the position of the crank arm and roller with the spoiler handle in unarmed and armed positions.

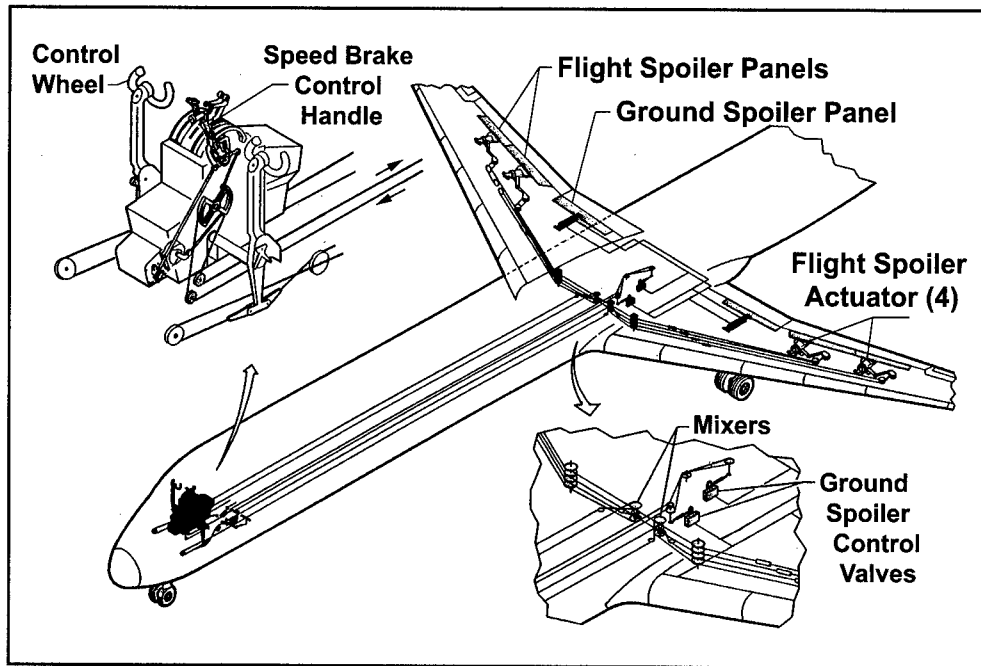

Figure 2. Spoiler Control System

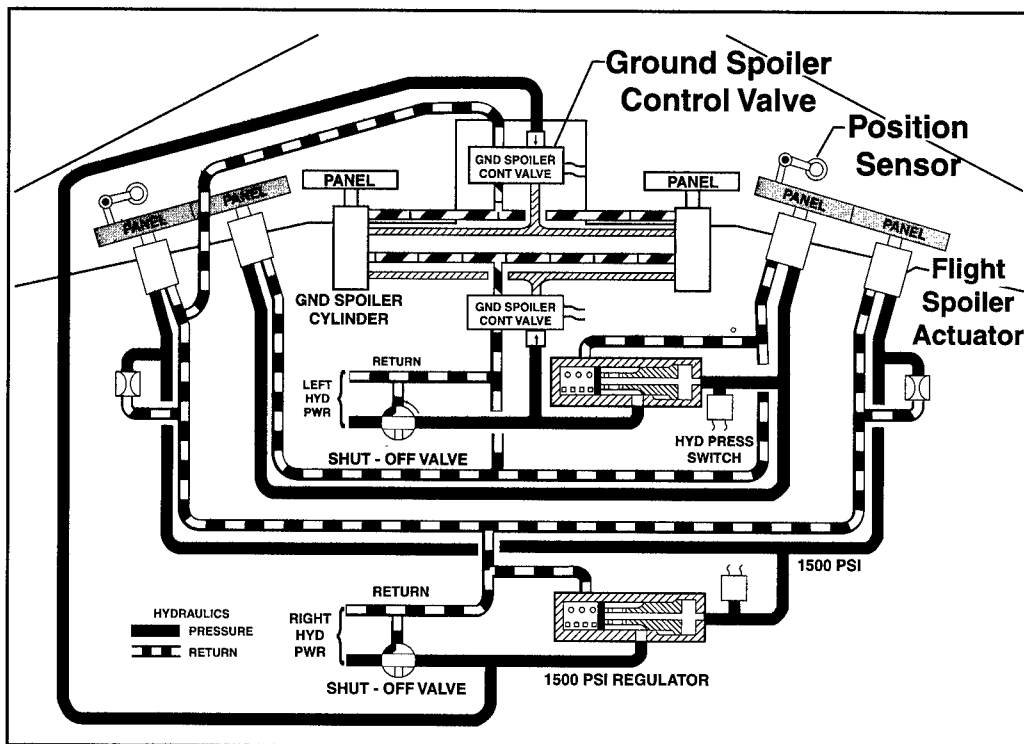

Figure 3. Spoiler Hydraulic System

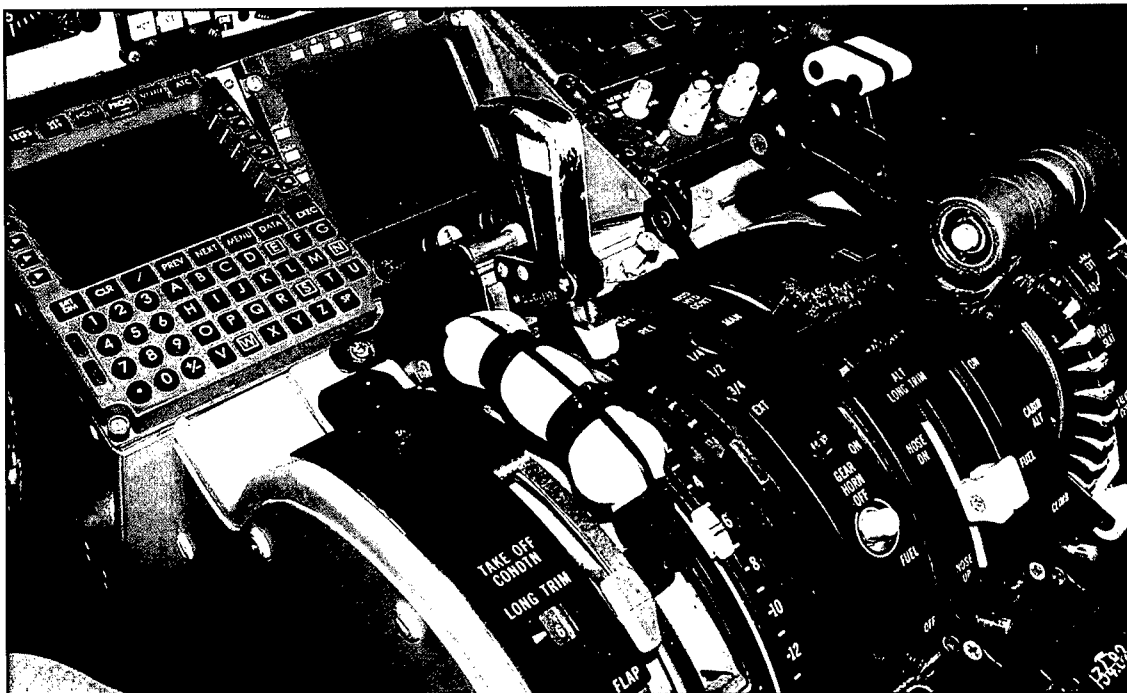

Figure 4. Spoiler Handle in the Unarmed Position

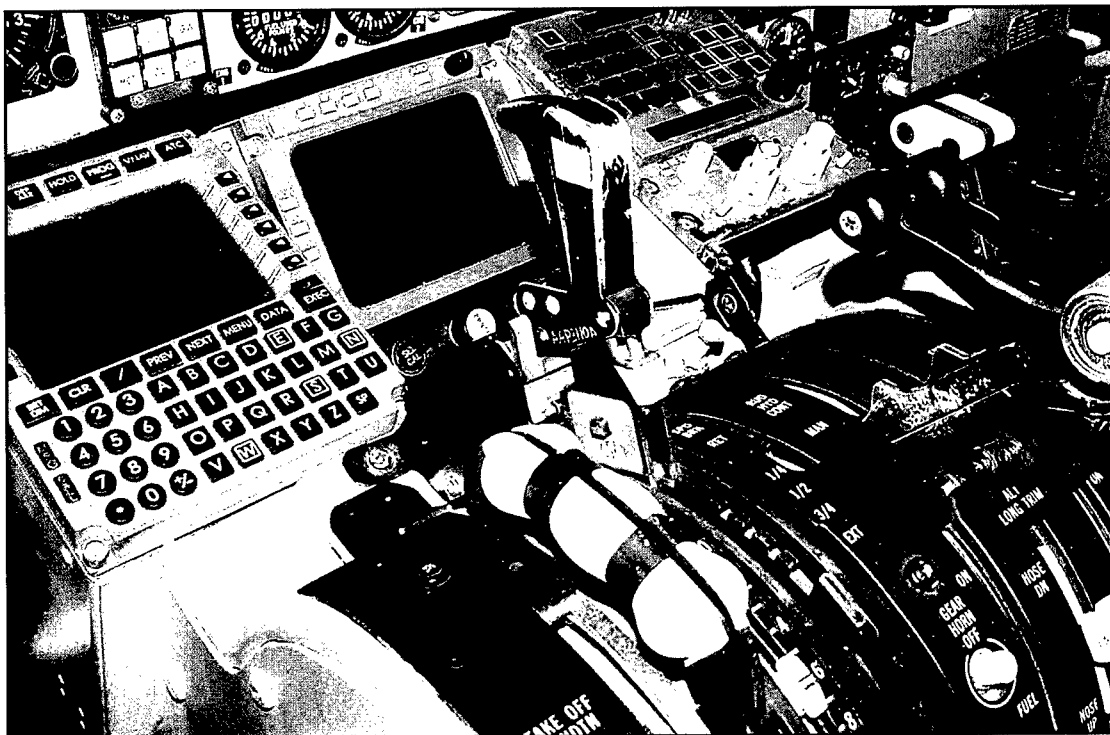

Figure 5. Spoiler Handle in the Armed Position

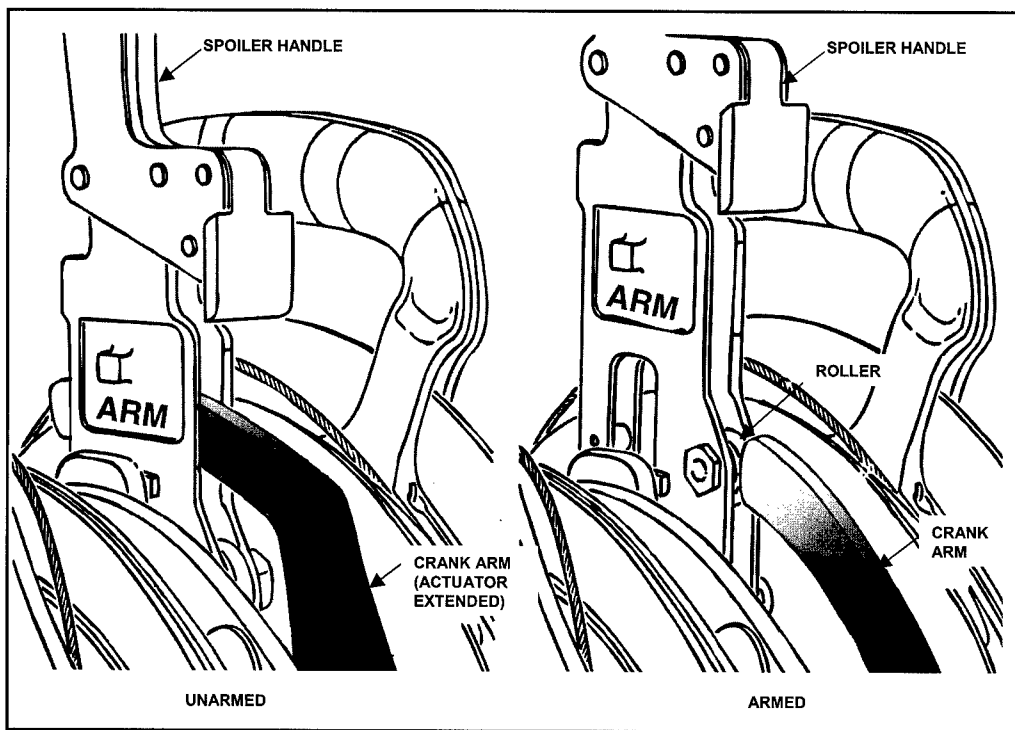

Figure 6. Position of the Crank Arm and Roller With the Spoiler Handle in the Unarmed and Armed Positions (View From Forward Right to Aft Left)

1.6.2.1 Testimony on Spoiler System Operation

According to the Boeing Company's Engineering Manager for Landing Gear, Brake, and Hydraulic Systems, who testified at the Safety Board's public hearing on this accident, the autospoiler system provides "quick, timely, and full 60° deployment" of all spoiler panels with "minimal flight crew input" during a rejected takeoff or after a landing touchdown. The Engineering Manager stated that the only human factor involved in the system's operation is the arming of the spoilers to ensure that the autospoiler system can successfully engage and actuate the spoiler system. The Engineering Manager also testified that the spoiler system is very reliable. For example, if the spoilers were armed and tire spin-up did not occur upon touchdown, the spoilers would still automatically deploy because the system was designed to use nose gear compression as the backup signal for spoiler deployment.

The Engineering Manager indicated that the two spoiler parameters on the accident airplane's FDR appeared to be functioning normally. He explained that a full turn of the steering yoke in the cockpit (that is, a full aileron deflection) would have caused the right inboard flight spoiler to fully deflect momentarily, as indicated by FDR data. The Engineering Manager testified that the right flight spoilers reduced lift on that wing for only about 2 seconds, which would not have made much difference in the airplane's braking.

The Engineering Manager said that there are no design features in the autospoiler system to warn pilots that the spoiler handle has not been armed. He added that some changes have been made to the system since it was designed in the 1960s, but most of these changes have been to ensure that the ground spoilers do not inadvertently deploy during flight. According to the Engineering Manager's testimony, the electrical signal required to deploy the ground spoilers requires all of the following: the landing gear handle switch is in the down position, the left or right main landing gear weight-on-wheels signal is received from the proximity system electronic unit, and the left throttle switch is in the idle position.

The Engineering Manager further testified that there are no aural or visual warnings in the cockpit to indicate that the spoilers did not deploy. However, there are some aural and visual cues to indicate to the flight crew that the spoilers have been deployed, including the extensive motion of the spoiler handle as it is moving into the extend position and the associated "clanking" sound.

An aerodynamics engineer from Boeing presented information on the effect of the spoilers on the weight on the wheels for a 127,000-pound MD-80 series airplane at 1 second after touchdown (the point during the landing roll when the airplane is at its highest speed and is developing the highest lift). The weight distribution of the airplane was estimated according to the percent of total landing weight supported by the wings, the main landing gear, and the nose gear.

With the spoilers deployed, about 20 percent of the airplane's total landing weight is supported by the wings, about 77 percent of the total weight is supported by the main gear, and about 3 percent of the total weight is supported by the nose gear. Without spoilers, about 70 percent of the airplane's total landing weight is supported by the wings, about 27 percent of the total weight is supported by the main gear, and about 3 percent of the total weight is supported by the nose gear.³⁵ Without spoilers and with an additional 20 knots of speed, about 90 percent of the airplane's total landing weight is supported by the wings, about 7 percent of the total weight is supported by the main gear, and about 3 percent of the total weight is supported by the nose gear. According to the Boeing engineer, this finding is important because, when less weight is applied on the main gear, it has less braking force and produces less cornering force in a skid.

1.6.2.2 Other Spoiler Events

During the public hearing on this accident, the Safety Board requested that Boeing determine whether it had received any reports of armed autospoilers not deploying on MD-80 or DC-9 aircraft. Boeing sent two letters, dated April 20 and October 24, 2000, to the Safety Board that indicated that the company was able to find nine records of such reports. Most of these events could be explained by either component or procedural

³⁵ The estimated weight distribution for landings without spoilers assumed a 10° nose-down elevator. The Boeing engineer stated that applying nose-down elevator reduces the weight on the main gear by transferring it to the nose gear. He also stated that, because the nose gear does not have any brakes, the braking force is reduced and the distance to stop is increased.

failures. For example, Boeing stated that an autospoiler actuator on a DC-9 was removed and replaced because the spoiler handle did not come all of the way back and latch. In another example, Boeing indicated that the autospoilers on a DC-9 did not deploy on landing but that an inspection revealed that the autospoiler circuit breaker was open. For the remaining events, the data were insufficient to verify the details of the event or determine the cause.

American Airlines reported two instances in which the spoiler handle aboard an MD-80 series airplane extended and then retracted after main landing gear touchdown. The events occurred at Dallas/Fort Worth on June 15, 2000, aboard flight 497 and on September 17, 2000, aboard flight 787. The FDR from the flight 497 airplane only recorded the right outboard spoiler position at a sampling rate of once per second, and the FDR indicated that the spoiler deployed at touchdown and then retracted about 1 second later. The FDR from the flight 787 airplane showed that both the left outboard and right inboard flight spoilers deployed at touchdown and then retracted about 1 second later. According to American, both flight crews could feel the spoilers retract, after which the crews manually deployed the spoilers and safely decelerated the airplanes. American also indicated that the flight crews believed the throttles were idle at touchdown.

1.6.3 Braking System Information

The MD-80 series airplane braking system can be operated manually or automatically. The automatic braking (autobrake) system on the MD-80 is optional; the accident airplane was equipped with the system. According to Boeing's Engineering Manager for Landing Gear, Brake, and Hydraulic Systems, the MD-80 autobrake system provides "rapid and full application of the brakes" in the event of a rejected takeoff and "timely and consistent brake application" during landing. The first officer stated in a postaccident interview that the captain elected to use only manual brakes for landing.³⁶

The autobrake system control panel is on the aft right portion of the center pedestal. To arm the system before landing, a pilot selects one of three deceleration levels—minimum, medium, and maximum—and moves the arm switch to the ARM position. After landing, the spoiler handle is moved aft either manually or automatically by the autospoiler system, and the autobrake switches then initiate the automatic application of the brakes. (The autobrakes will operate only if the spoiler handle is in the extended position.) With the minimum and medium levels, brake application begins about 3 seconds after landing; with the maximum level, brake application begins about 1 second after landing.

The autobrake system can be unarmed so that the braking function is returned to the pilots. The system is unarmed by manually depressing any brake pedal more than 25 percent of its maximum travel, advancing any throttle out of the near-idle range,

³⁶ The CVR indicated that, at 2331:22, the first officer stated, "manual brakes?" to which the captain replied, "uh, manual's fine."

moving the arm switch to the DISARM position, or returning the spoiler handle to the stowed position.

MD-80 series airplanes are equipped with an antiskid braking system. This system adapts braking pressure (applied manually or automatically) to runway conditions by sensing an impending skid condition and adjusting the brake pressure on each individual wheel to allow for maximum braking performance. The inboard brakes have touchdown protection to prevent them from being applied before or at touchdown. The outboard brakes do not have touchdown protection.

1.6.4 Weight and Balance

According to the trip paperwork, the takeoff center of gravity for N215AA was 16.7 percent of mean aerodynamic chord, which was within the approved limits of the airplane. The trip paperwork also included the following information for the airplane: basic operating weight, 83,123 pounds; passenger weight, 25,020 pounds; baggage weight, 3,475 pounds; zero fuel weight, 111,618 pounds; fuel, 24,500 pounds; ramp weight, 136,118 pounds; taxi fuel burn, 2,080 pounds; takeoff weight, 134,038 pounds; estimated fuel burn, 6,289 pounds;³⁷ and estimated landing weight, 127,749 pounds. The zero fuel, ramp, takeoff, and landing weight maximums were 122,000; 150,500; 136,300; and 130,000, respectively.

1.6.5 N215AA's Previous Flights on the Day of the Accident

On the day of the accident, N215AA flew from Dallas/Fort Worth to Denver and back to Dallas/Fort Worth. The captain of those flights indicated, in a postaccident interview, that the spoilers were armed and deployed normally for each landing. He also indicated that the weather radar worked well during deviations around weather in the Denver area. The first officer of those flights stated, in a postaccident interview, that the spoilers, thrust reversers, and manual brakes worked normally. He also stated that the airplane's weather radar operated normally in the 20-, 40- 80- and 160-mile ranges.

FDR data for the accident airplane's previous landing at Dallas/Fort Worth showed that the flight spoilers deployed symmetrically immediately after touchdown to their full 60° position and remained that way for about 33 seconds until they returned to their stowed position. Boeing's Engineering Manager for Landing Gear, Brake, and Hydraulic Systems indicated that the FDR data for the airplane's previous landing "definitely" showed normal spoiler deployment. FDR data also showed that both thrust reversers deployed after the airplane touched down at Dallas/Fort Worth.³⁸

³⁷ The flight dispatcher sent the flight crew an ACARS message about 2311, which revised the fuel burn amount to allow for en route weather deviations. The message also included a reminder to the flight crew that Nashville and Dallas/Fort Worth airports were the flight's two alternate airports.

³⁸ According to FDR data, both thrust reversers also deployed when the airplane powered back from the gate during its departure from Dallas/Fort Worth to Little Rock.

1.6.6 MD-80 Demonstrated Landing Distance

As part of an airplane's certification, a manufacturer must demonstrate the distance to land from a 50-foot height to a complete stop (14 CFR 25.125). The aerodynamics engineer from Boeing, in public hearing testimony, stated that the MD-80 "demonstrated landing distance" was measured in two parts—the air distance, from 50 feet to touchdown, and the ground distance, from touchdown to stop—and on a dry, hard-surfaced runway. According to the aerodynamics engineer, the operating requirements in Part 121 provide for additional safety margins beyond the demonstrated landing distance, specifically, variations in the speed, touchdown point, runway surface condition, tire condition, temperature, and runway slope. The Part 121 minimum dry runway length is the demonstrated landing distance plus 67 percent. The Part 121 minimum wet runway length is the minimum dry runway length plus 15 percent.

The Boeing engineer testified that the MD-80's landing performance was demonstrated to the FAA using the following test conditions: forward center of gravity, V_{ref} (1.3 times the stalling speed) at 50 feet, 40° flaps, autospoilers, pilot-actuated (manual) antiskid braking, no reverse thrust, and a weight range of 109,200 to 149,500 pounds. The engineer presented information regarding the required landing distances for an MD-80 with a landing weight of 127,000 pounds. The actual demonstrated landing distance was 2,830 feet, so the Part 121 minimum dry and wet runway lengths were 4,715 and 5,425 feet, respectively. Runway 4R/22L at Little Rock National Airport is 7,200 feet in length, so there is about an 1,800-foot margin between the required minimum wet runway length and the end of the runway.

1.7 Meteorological Information

1.7.1 Airport Weather Information

Weather observations at Little Rock National Airport are made by an Automated Surface Observing System (ASOS), which is maintained by the NWS. The ASOS records continuous information on wind speed and direction, cloud cover, temperature, precipitation, and visibility. The ASOS wind anemometer is installed 32 feet afl. The ASOS transmits an official meteorological aerodrome report (known as a METAR) at 53 minutes past each hour and a special weather observation (known as a SPECI) as conditions warrant; such conditions include a wind shift, change in visibility, and change in ceiling (cloud cover or height). The system is prevented from issuing any reports between 47:20 and 53:20 after the hour (known as the lockout period) so that the hourly observation can be prepared, edited, and transmitted.

ASOS observations at the Little Rock airport are augmented by certified weather observers under contract with the FAA. The augmentation station is located in the airport's terminal building, and the ASOS unit is located near the approach end of runway 4L. The NWS inspected the ASOS unit on May 21, 1999, and found it to be working properly.

The ASOS special weather observation for 2323 was as follows:³⁹

Special weather observation for Little Rock at 0423Z, winds from 180° at 09 knots, visibility 7 miles with thunderstorms, a few clouds at 7,000 feet in cumulonimbus clouds, ceiling broken at 10,000 feet, temperature 25° C, dew point temperature 23° C, altimeter 29.86 inches of Hg. Remarks: ASOS observation, thunderstorm began at 23 minutes past the hour, frequent lightning in-cloud and cloud-to-cloud located from the west through the northwest,^[40] thunderstorm west through northwest, moving northeast.

The ASOS edit log indicated that, at 2347:22, a special observation was canceled because it occurred during the lockout period. The ASOS edit log also indicated that the following observation was recorded about the time of the accident but was not disseminated because of the lockout period:

Little Rock weather observation at 0450:31Z, winds from 290° at 16 knots gusting to 28 knots, visibility 1 1/2 miles in thunderstorm and heavy rain^[41] and mist, a few clouds at 3,700 feet, ceiling overcast 5,000 feet, temperature 18.9° C, dew point 16.7° C, altimeter 29.94 inches of Hg. Remarks: ASOS observation, peak wind from 290° at 35 knots at 0433Z, wind shift at 0431Z, thunderstorm began at 0423Z, rain began at 0424Z, sea level pressure 1014.0 mb [millibars], frequent lightning in-cloud, and cloud-to-cloud, west through northwest, occasional lightning in-cloud, cloud-to-cloud, and cloud-to-ground east, thunderstorm west through northwest, thunderstorm east moving east, precipitation since last hourly observation 0.37 inches.

The hourly observation about 2353 indicated that the wind was from 280° at 18 knots gusting to 26 knots and that visibility was 1 mile in thunderstorms and heavy rain and mist. A special observation was issued about 2355, indicating that the wind was from 290° at 13 knots gusting to 26 knots and that visibility was 3/4 mile in thunderstorms and heavy rain and mist. Another special observation, issued about 2358, indicated that the wind was from 290° at 10 knots gusting to 76 knots; the winds were varying from 210 to 030°; the visibility was 1/2 mile in thunderstorms, small hail, heavy rain, and mist; and a peak wind from 320° at 76 knots was measured about 2356.

ASOS also provides precipitation measurements in 1- and 15-minute increments. Between 2331 and 2345, the ASOS measured 0.14 inch of rain, with the first measurable rain greater than trace amounts (less than 0.01 inch) about 2336. About 2350 (immediately before the time of the accident), the system measured a total of 0.37 inch of rain. The 15-minute measurement for 2346 to 0000 indicated that 1.09 inches of rain had fallen.

³⁹ Weather observations are transmitted in coordinated universal time (UTC). The “Z” designation that follows the time in the weather observation stands for Zulu, which indicates UTC time. Central daylight time is 5 hours behind UTC time.

⁴⁰ The Federal Meteorological Handbook number 1 defines frequent lightning as one to six flashes per minute.

⁴¹ The NWS defines heavy rain as 0.03 inch of rain within 6 minutes or more than 0.30 inch of rain per hour.

Appendix C shows detailed ASOS wind information and precipitation amounts surrounding the time of the accident.

ATIS information is based on ASOS observations provided to the tower by the official airport weather observer.⁴² ATIS information Romeo, which was current beginning about 2326, stated:

Good evening Little Rock Adams Field⁴³] information Romeo zero four two two Zulu special observation, wind one niner zero at one four, visibility seven, thunderstorm, few clouds at seven thousand, cumulonimbus, ceiling one zero thousand broken, temperature two five, dew point two three, altimeter two niner eight eight, frequent lightning in-cloud, cloud-to-cloud, west through northwest, moving northeast. ILS runway two two left approach in use. Notices to Airmen, runway two two right, four left ILS out of service. Attention all aircraft, hazardous weather information for the Little Rock area available on HIWAS [Hazardous In-flight Weather Advisory Service], flight watch, or flight service...advise on initial contact you have Romeo.

In addition to ASOS, Little Rock National Airport is equipped with an FAA Type FA-10240 Low Level Windshear Alert System (LLWAS), which was operational at the time of the accident. The LLWAS uses six wind sensors at remote stations located around the airport to collect wind speed, direction, and gust data.⁴⁴ One of the six sensors is the centerfield wind sensor, which is installed 70 feet afl. Readings from this sensor are used by tower controllers as the source of real-time wind data for pilots. LLWAS alerts are displayed in the ATCT so that controllers can warn flight crews of potentially hazardous windshear conditions. (As discussed in section 1.1, the controller transmitted windshear alerts to the 1420 flight crew about 2339 and 2347.) The FAA performed a sensor performance evaluation after the accident, which determined that all of the LLWAS sensors were working properly at the time of the accident.

The Safety Board requested that the Massachusetts Institute of Technology's Lincoln Laboratory review the LLWAS data. According to public hearing testimony by Lincoln Laboratory's Source Scientist for the LLWAS and TDWR⁴⁵ algorithms, the

⁴²FAA Order 7110.65, section 2-9-2, states that towers are required to make a new ATIS recording whenever the following situations occur: any new official weather is received (even if there has not been a change in values), runway braking action reports indicate that runway braking is worse than the description included in the current ATIS broadcast, and any other pertinent information has changed (for example, the runway or the instrument approach in use and new or canceled notices to airmen, pilot reports, or HIWAS updates).

⁴³Little Rock National Airport is also known as Adams Field.

⁴⁴ According to the FAA's Program Manager for LLWAS, the FAA plans to upgrade the current system in May 2002 to an LLWAS-RS, which will involve adding and relocating sensors and upgrading software. Other airports will have their LLWAS systems upgraded to either the LLWAS-RS or LLWAS-NE version, which will involve a network expansion. LLWAS-NE versions will be integrated with Terminal Doppler Weather Radar (TDWR) systems or the Weather Systems Processor (WSP, see section 1.18.5.1).

⁴⁵ TDWR is a C-band radar installed at 41 major U.S. airports. TDWR provides timely and accurate detection of hazardous windshear in and near airport terminal approach and departure areas. It also provides microburst, gust front, wind shift, and precipitation intensity information.

LLWAS alerts issued on the night of the accident “were very credible and gave a good interpretation of what was going on.” This witness also testified that, after the airplane landed on the runway, the LLWAS centerfield sensor surged to 41 knots and that a microburst had begun to impact the airport by 2352.⁴⁶ (An LLWAS alert related to this event was recorded at 2352:10.)

The Safety Board reviewed the tapes made by the airport’s surveillance cameras for additional information on the weather conditions before the time of the accident. The surveillance cameras recorded heavy rain, strong gusting winds, lightning, and deteriorating visibility.

1.7.2 National Weather Service Information

The NWS prepared several weather products describing the conditions surrounding the time of the accident. A terminal aerodrome forecast (TAF), prepared by the North Little Rock Forecast Office, was issued about 1830 and was amended about 2258.⁴⁷ The amended TAF, which was valid starting about 2300, stated, in part, the following:⁴⁸

Beginning at 0400Z, winds forecasted from 200° at 12 knots gusting to 20 knots, visibility greater than 6 miles, scattered clouds at 2,500 feet, ceiling overcast at 6,000 feet. Temporary condition between 0400Z and 0600Z, winds variable at 25 knots gusting to 40 knots, visibility 1 mile in thunderstorm, heavy rain and mist, ceiling overcast at 1,500 feet in cumulonimbus clouds.

NWS in-flight weather advisories notify pilots en route of the possibility of encountering hazardous flying conditions that may not have been forecast at the time of their preflight briefing. Two of the five NWS in-flight weather advisory categories—Convective SIGMET and Severe Weather Forecast Alert—were in effect at the time of the accident.⁴⁹

Convective SIGMET⁵⁰ No. 15C, prepared by the NWS Aviation Weather Center in Kansas City, Missouri, was issued about 2255 and was valid until 0555 on June 2, 1999. The advisory was broadcast in its entirety to the flight crew about 2304 and stated the following:

⁴⁶ A microburst is a severe localized wind blasting down from a thunderstorm. A microburst usually covers an area of less than 2 1/2 miles in diameter and lasts less than 20 minutes.

⁴⁷ TAFs are normally issued every 6 hours with amendments issued as conditions warrant.

⁴⁸ The NWS Aviation Forecaster in North Little Rock indicated that he amended the 1830 TAF because, by 2250, he realized that the line of thunderstorms and heavy rain would be impacting the airport within the next hour. The 1830 TAF was included in the preflight weather package to the flight crew (see section 1.7.3).

⁴⁹ The other three NWS in-flight weather advisory categories are SIGMETs, center weather advisories, and airman’s meteorological information (better known as AIRMETs).

⁵⁰ A Convective SIGMET implies severe or greater turbulence and microburst/windshear activity.

Attention all aircraft, Convective SIGMET 15 Central valid until 0555 Zulu for Arkansas and Oklahoma...area of severe thunderstorms moving from 300 at 20 knots, tops above flight level 450, hail to two inches, and wind gusts to seven zero knots possible. Additional hazardous weather information for Arkansas and Oklahoma available from flight service, flight watch, or HIWAS frequencies.

Severe Weather Forecast Alert No. 357, prepared by the NWS Storm Prediction Center in Norman, Oklahoma, was issued about 2123 and was valid until 0300 on June 2, 1999. The advisory, which encompassed portions of northern Texas, northwest Louisiana, Arkansas (including Little Rock), and southeast Oklahoma, warned of a few severe thunderstorms with hail to 2 inches, extreme turbulence, and surface wind gusts to 70 knots; a few cumulonimbus clouds with maximum tops to 50,000 feet; and a mean storm motion from 280° at 20 knots.

A Weather Surveillance Radar 1988 Doppler (WSR-88D) system located in North Little Rock (6 miles north-northwest of the airport) provides a three-dimensional volume scan of the atmosphere at varying degrees of elevation and within a range of 240 miles. The five lowest elevation angles for this WSR-88D are 0.4, 1.5, 2.4, 3.3, and 4.3°. ⁵¹ The volume scan process takes 6 minutes.

The WSR-88D's composite reflectivity image of all elevation scans from 2345 depicted a northeast-to-southwest-oriented band of weather, with several large areas indicating reflectivities of level 6 (extreme) activity, ⁵² encompassing the Little Rock airport area. Reflectivities over the airport ranged from 50 to 64 decibels (dBz), or level 5 (intense) to 6 (extreme) activity. The 2351 composite reflectivity image continued to depict the large weather band surrounding the airport and the 50- to 64-dBz reflectivity range over the airport.

The WSR-88D's base reflectivity images provided the radar reflectivities at the individual elevation scans. The images documented the line of thunderstorms moving across the Little Rock airport area during flight 1420's approach. The WSR-88D 0.4° elevation scan of base reflectivity that was completed at 2334:27 depicted reflectivities of 50 dBz, or NWS level 5 (intense) activity over the northwest section of the airport. By 2340:28, the 0.4° base reflectivity image depicted a large area of activity over the airport with reflectivities of 45 dBz, or level 4 (very strong) activity, and greater. The two strongest areas of activity were located approximately 5 miles west-northwest and northeast at this time. Another area of activity located approximately 3 miles southwest of Little Rock was beginning to move toward the east-southeast with reflectivities reaching 54 dBz, or level 6 (extreme) activity. Figures 7 and 8 show the base reflectivity products for 2334:27 and 2340:28, respectively.

⁵¹ The 0.4° elevation scan covered conditions near the surface of the airport. The 1.5° elevation scan covered conditions encountered in the area approaching the airport.

⁵² The NWS categorizes reflectivity according to a six-level intensity scale; level 6 is the highest, measuring greater than 54 decibels. The other levels are 1, very light; 2, light to moderate; 3, strong; 4, very strong; and 5, intense.

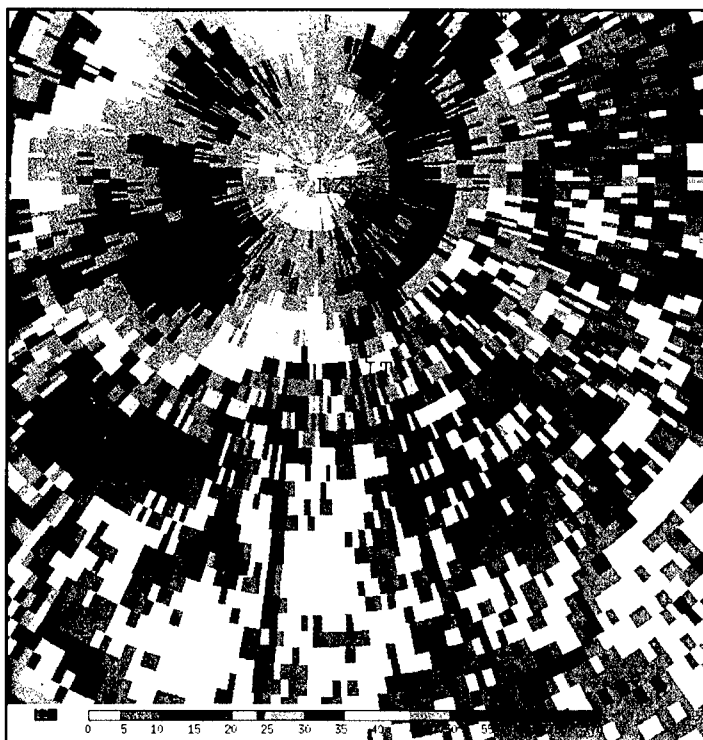

Figure 7. 0.4° Base Reflectivity Scan at 2334:27

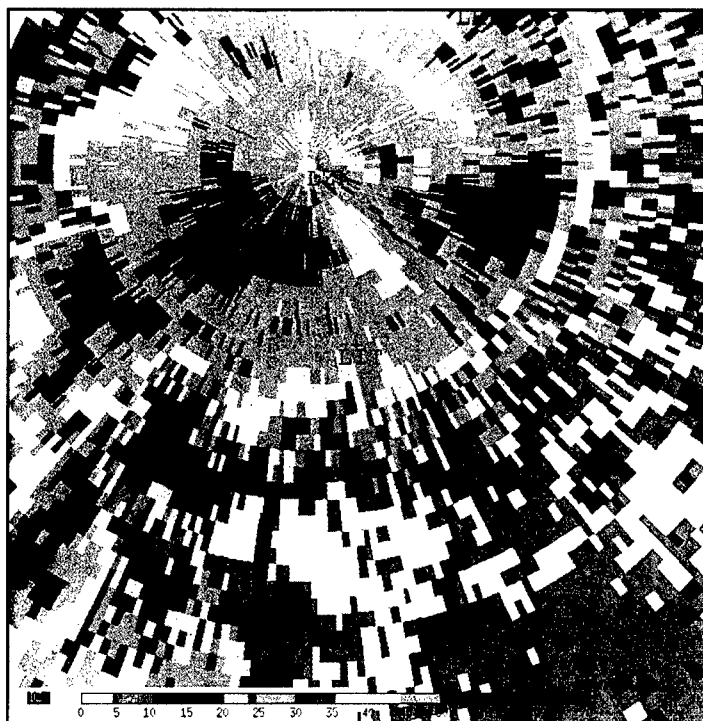

Figure 8. 0.4° Base Reflectivity Scan at 2340:28

The WSR-88D's 0.4° elevation scan of base reflectivity that was completed at 2345:57 indicated that the area over the airport and the approach end of runway 4R reached reflectivities of 54 dBz, or level 5 (intense) activity, and that the area approximately 5 miles west of runway 4R reached maximum reflectivities of 61.5 dBz, or level 6 (extreme) activity. Figure 9 shows the base reflectivity product for this time period.

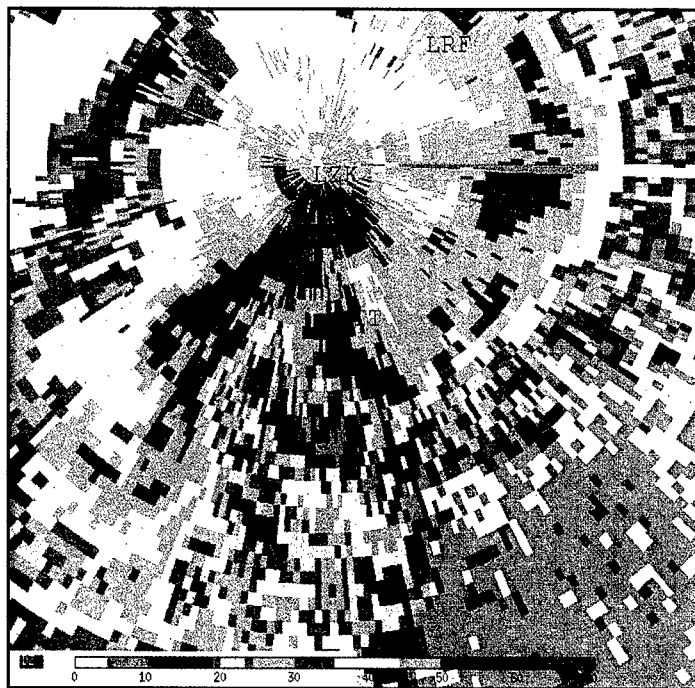

Figure 9. 0.4° Base Reflectivity Scan at 2345:57

At 2351:59, the 0.4° base reflectivity image depicted a maximum of 52 dBz, or level 5 (intense) activity, along the flight track, with maximum reflectivities of 60 dBz, or level 6 (extreme) activity, located 1 1/2 miles to the northwest. Figure 10 shows the base reflectivity product for this time period. Also, the 1.5° elevation scan at 2353:03 indicated returns of 58 dBz, or level 6 activity, with maximum reflectivities of 62.5 dBz 1/2 mile from the approach end of runway 4R.

The WSR-88D's radial velocity image (showing components of the wind speed that are coming directly toward or away from the radar) for 2346:29 indicated that winds from the northwest at 15 meters per second (30 knots) were over runway 4R. Figure 11 shows the radial velocity image for this time period with the airplane's flight track. At 2352:30, the radial velocity image depicted winds from the northwest at 18 meters per second (36 knots) over the runway with winds reaching 30 meters per second (60 knots) within 1/2 mile of the approach end of the runway.

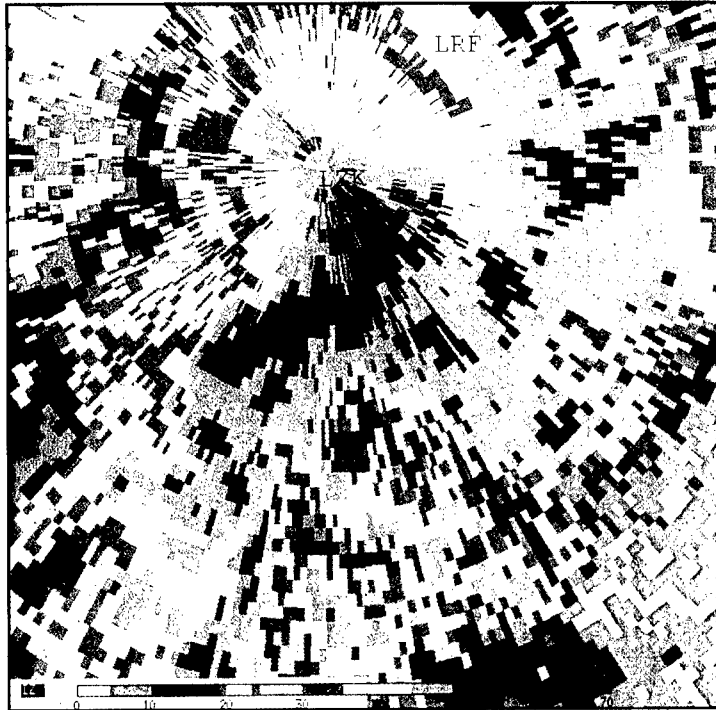

Figure 10. 0.4° Base Reflectivity Scan at 2351:59

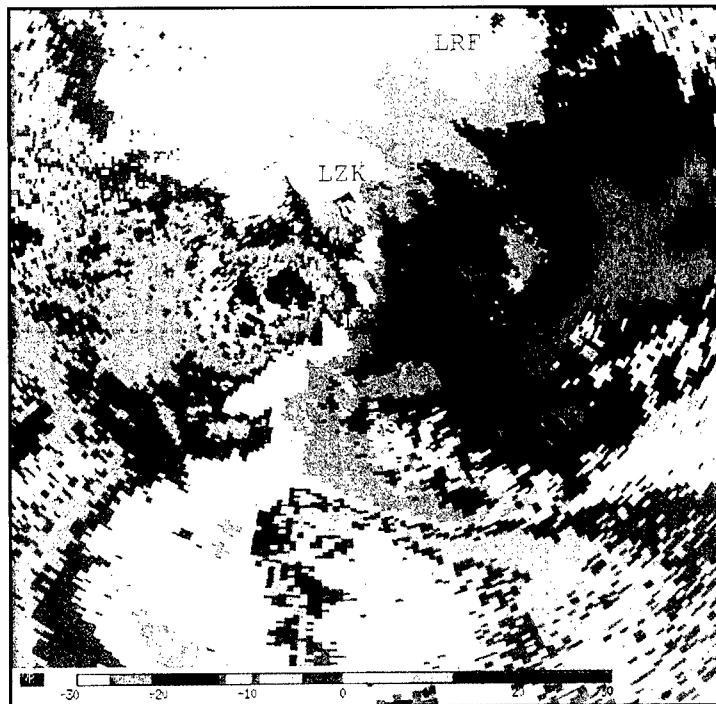

Figure 11. Radial Velocity Image Surrounding the Time of the Accident

The 1900 upper air sounding (that is, an evaluation of the conditions supporting the development of severe storms) from the NWS Forecast Office in North Little Rock was valid beginning about 2000. The upper air sounding included several stability indexes, which indicated that the atmosphere was unstable with a high potential for severe thunderstorms.

In addition, the NWS issued two public weather warnings for severe thunderstorms in the Little Rock area. The first warning was issued about 2156 and was valid until 2245, and the second warning was issued about 2317 and was valid until 0020 on June 2, 1999. Both warnings indicated the threat of strong winds and the potential for hail, and the general public was warned to stay indoors until the storms passed. These weather warnings were made available to the local Little Rock area, and the tower received these warnings through its direct line with the NWS. The FAA does not require controllers to provide pilots with public weather warnings because they are not considered aviation products and contain no aviation references. The local controller did advise a pilot of a light multiengine airplane, which departed the airport about 2328, of the second public weather warning because that airplane was traveling northbound toward the counties covered by the warning. Flight 1420 was approaching the airport from the south and was not on the tower's frequency at the time.

1.7.3 American Airlines Weather Information

At Dallas/Fort Worth, the flight crew viewed a graphical display of the weather radar and received a preflight weather package that contained weather information issued about 2205. The information included reports, forecasts, and notices to airmen for the departure, destination, and alternate airports and the current in-flight weather advisories for the routes. A thunderstorm SIGMEC [significant meteorological condition] stated the following:⁵³

En route thunderstorm SIGMEC. Valid from 0255Z through 0800Z on June 2, 1999. Over Texas, Louisiana, Arkansas, and Oklahoma. Coverage widely scattered area of thunderstorms located from 10 miles northeast of Fayetteville, AR, to Little Rock, AR, to Texarkana, AR, to Paris, TX, to Fayetteville, AR, then back to 10 miles northeast of Fayetteville. Thunderstorms moving to the east at 20 knots. Maximum tops at and above 50,000 feet. Outlook, thunderstorms increasing through 0600Z and then decreasing.

Other in-flight weather advisories included in the preflight weather package were a brief of NWS Severe Weather Forecast Alert No. 357 and NWS Convective SIGMET No. 11C, which indicated an area of severe thunderstorms moving from 300° at 20 knots with cloud tops above 45,000 feet and the possibility of hail to 2 inches and wind gusts to 70 knots. The SIGMET was valid over portions of Arkansas (including Little Rock), Oklahoma, and Texas until 2355, but Convective SIGMET 15C replaced it about 2255. The preflight weather information also included the 2153 ASOS observation, the TAF

⁵³ A SIGMEC is an American Airlines-issued weather advisory about conditions that may influence the safety of flight operations.

issued at 1830,⁵⁴ and airport field conditions for Little Rock (all runways were open and wet, with 0 inch of water and no reports of braking action problems).

The American Airlines flight dispatcher was using a high-resolution Weather Services International radar mosaic product to track the weather in relation to an airplane's flightpath. The radar mosaics eliminate false echoes and ground clutter, but the product is delayed by several minutes.⁵⁵ The flight dispatcher indicated, during public hearing testimony, that he received updates on the weather every 15 minutes but that the radar data were 5 to 15 minutes old by that time. The dispatcher also indicated that he did not have access to real-time WSR-88D single-site weather data or TDWR.⁵⁶

The flight dispatcher's 2254 ACARS message to the flight crew stated the following:

Right now on radar there is a large slot to Little Rock. Thunderstorms are on the left and right, and Little Rock is in the clear. Sort of like a bowling alley approach.⁵⁷ Thunderstorms are moving east-northeastward toward Little Rock and they may be a factor for our arrival. I suggest expediting our arrival in order to beat the thunderstorms to Little Rock if possible.

About 2257, the flight crew sent an ACARS message, requesting weather information for Little Rock airport. The flight crew received the 2153 ASOS observation, which was already included in the preflight weather package. The 2253 ASOS observation was not available to the flight crew until after 2300.

The flight dispatcher stated that he did not see the 2258 amended TAF (which changed the wind direction and was more specific regarding the impact period of the thunderstorm). The dispatcher did not receive the amended TAF because it was issued when American's primary weather circuit from the FAA was preparing to receive hourly weather observation information.

⁵⁴ This TAF, which was valid beginning about 1900, indicated that the visibility beginning about 2300 would be greater than 6 miles and that the probability of a thunderstorm between 2300 and 0300 on June 2 was greater than 50 percent.

⁵⁵ To eliminate ground clutter, a computer program compares the images with previous observations and local ground clutter patterns and then overlays the images with the other data to correct for beam height and distance errors.

⁵⁶ The flight dispatcher indicated that the Internet has sites that use Doppler weather radar technology to depict weather information but that he did not have access to such information.

⁵⁷ In public hearing testimony, the flight dispatcher indicated that the "bowling alley" message was meant to be as brief and concise as possible but give the pilots an image of what to expect because the airborne weather radar was not able to show a full area of coverage. According to the CVR, the captain stated at 2326:52, "this is the bowling alley right here," and at 2332:31, "down the bowling alley."

1.7.4 Additional Weather Information

1.7.4.1 Lightning Data

American Airlines provided the Safety Board with a display from the National Lightning Detection Network⁵⁸ depicting 1,177 lightning strikes over the state of Arkansas between 2345 and 2400. The Board used lightning verification reports from this network to determine that, between 2346 and 2351, 903 cloud-to-ground lightning strikes were detected within 20 miles of the center of the airport and 46 cloud-to-ground lightning strikes were detected within 5 miles of the center of the airport.

1.7.4.2 Witness Statements

The Safety Board interviewed two witnesses to the weather conditions surrounding the time of the accident. One witness, a cross-country truck driver in the vicinity of the airport, indicated that “torrential rain” was occurring when he saw the accident airplane “coming in cocked with the wings tilted to the right.” He also stated that “strong gusty winds,” “intermittent golf ball size hail,”⁵⁹ and “almost continuous” lightning were occurring after he saw the airplane. The other witness was waiting in the airport terminal for his wife. He indicated that hail had started just before the airplane landed and that the hail was “really hard” when the airplane touched down. He stated that thunder and lightning were occurring simultaneously. He further stated that the thunder vibration “felt like it would break the glass [on the windows in the terminal]” and that the hail had cracked the glass.

1.7.4.3 Windshear Hazard Study

A research scientist with the National Aeronautics and Space Administration’s (NASA) Langley Research Center in Hampton, Virginia, examined available weather data and conducted modeling simulations to determine the turbulence, windshear, and crosswind hazards surrounding the time of the accident. The draft report on this research indicated that a strong “bow echo” squall line system approached the airport during the time of the accident and produced hazardous crosswinds.⁶⁰ According to the report, a bow echo refers to a radar echo that appears to undergo a forward acceleration at its midpoint, thus forming a bulge in the radar signature, and is known to harbor severe weather.⁶¹ The report also indicated that the accident airplane might not have encountered hazardous levels of windshear.

The report suggested that crosswind and windshear hazards were not synonymous because each affected airplane control differently. The report indicated that the hazards

⁵⁸ Global Atmospheric, Inc., in Tucson, Arizona, operates the National Lightning Detection Network.

⁵⁹ The leading edges of the airplane’s wings showed no damage that would be consistent with a heavy hail encounter.

⁶⁰ Proctor, Fred H. 1999. *Investigation of the Storm Associated With the 1 June 1999 Aircraft Accident at Little Rock, Arkansas*. NASA Langley Research Center.

⁶¹ The report added that a bow echo could be detected with conventional and Doppler radar.

associated with a crosswind threat were “collision with obstacles, lack of control authority on touchdown resulting in damage to aircraft and injury to passengers, [and] impaired directional control on the runway.” The report further indicated that the hazard associated with a windshear threat was “flight into terrain.” In addition, the report stated that hazardous crosswinds and windshear could affect airplanes at low altitudes during the approach and departure phases of flight but that crosswind could only affect airplanes during the takeoff and landing flight phases. The report concluded that advisories and alerts for hazardous crosswinds could be developed and implemented into existing LLWAS systems.

1.8 Aids to Navigation

The Little Rock VOR is on the 113.9 megahertz (mHz) radio frequency and has distance measuring equipment associated with it. The runway 4R/22L ILS is on the 111.3 mHz radio frequency. No problems with these navigational aids were reported.

1.9 Communications

No communications problems were reported between the flight crew and any of the air traffic control (ATC) facilities that handled flight 1420.

1.10 Airport Information

Little Rock National Airport is located immediately south of the Arkansas River and approximately 2 miles east of metropolitan Little Rock at an elevation of 260 feet msl. The airport is owned by the city of Little Rock and is operated by the Little Rock Municipal Airport Commission.

Little Rock National Airport has three concrete transverse grooved runways: 4L/22R, 4R/22L, and 18/36. Runway 4R/22L is 7,200 feet long and 150 feet wide and is equipped with high-intensity runway edge lights⁶² and centerline lights. (Runway 4L/22R is 8,273 feet long and 150 wide; runway 18/36 is 5,124 feet long and 150 feet wide.) Runway 4R is equipped with a medium-intensity approach lighting system with runway alignment indicator lights. Runway 22L has a medium-intensity approach lighting system with sequenced flashing lights and a precision approach path indicator.

There are published ILS approaches for runways 4L, 4R, 22L, and 22R. At the time of the accident, the ILS equipment for runway 4L/22R was out of service because of

⁶² The RVR system log, which records runway edge light settings once per hour indicated that, about 2344, the runway 4R edge lights were set at step 3. (Step 1 is the lowest edge light setting; step 5 is the highest.) The RVR log is the only available recorded information on the light setting before the accident. In a postaccident interview, the controller could not recall whether he changed the light setting after 2344 in response to the decreasing visibility.

the installation of upgrades. (Although the upgrade work had been completed, this ILS equipment remained unusable because it had not yet been flight checked.) Equipment monitor logs showed that the ILS equipment for runway 4R was operating normally. A postaccident flight check could not be conducted because the ILS localizer antenna was damaged during the accident sequence.

The FAA's Lead Systems Engineer for Navigation and Landing, in testimony at the Safety Board's public hearing on this accident, stated that a new-generation RVR system was installed for runway 4R/22L in August 1996. The new-generation system consists of an infrared transmitter source and an infrared transmitter receiver, which can detect rain, mist, or snow, and a runway sensor light, which computes the RVR.⁶³ The digital readout is transmitted to the tower, and local controllers use this information to indicate to pilots upward, downward, or steady trends. The display can be updated every 2 seconds based on the average for the preceding minute.

The RVR sensors are mounted about 18 feet above the ground and are located at both ends of the runway, near the ILS glideslope antennas and the painted touchdown zone markers, to detect the touchdown and rollout RVRs.⁶⁴ The system has a quarterly maintenance period involving calibration and certification. The system's last maintenance before the accident was on May 17, 1999. According to the Lead Systems Engineer, there were no indications of problems with the RVR system on the night of the accident. Also, an inspection was done on June 2, 1999, during which the system was recertified.

An archiving function within the RVR data processor unit can retain 12 hours of RVR data (the previous 2 hours and the following 10 hours). The unit must be set to start an event log within 2 hours of an occurrence, or the data will be lost. The 1-minute RVR data surrounding the time of this accident were not retained because an event log was not started within 2 hours.

RVR data at Little Rock are not reported directly to the airport's ASOS unit; the contract weather observer must obtain the 10-minute average visibility reading from the tower for inclusion in an observation.⁶⁵ The manager for the contract weather observers at Little Rock stated in a postaccident interview that the observers would not delay the transmission of an ASOS observation for an RVR reading.

⁶³ The earlier system used transmissometers—light sources that transmitted beams to receivers mounted on stanchions—to determine the RVR. The new system has been installed at about 150 U.S. airports.

⁶⁴ Runway 4R/22L was not equipped with sensors to detect the midpoint RVR.

⁶⁵ Annex 3 to the Convention on International Civil Aviation (Chicago Convention), Chapter 4 (dated May 11, 1998), includes recommended practices for Contracting States regarding meteorological observations and reports. Paragraph 4.1.8 states that “[weather] observation systems should include automated equipment for measuring or evaluating, as appropriate, and for monitoring and remote indicating of surface wind, runway visual range, cloud height, and...other meteorological parameters affecting landing and take-off operations.” The United States is 1 of 185 countries that are signatories to the Chicago Convention.

Little Rock National Airport is certified by the FAA as an aircraft rescue and fire fighting (ARFF) index C facility.⁶⁶ At the time of the accident, the FAA's most recent annual airport certification inspection was from July 29 to 31, 1998. The last full-scale airport disaster drill was held in October 1996.

According to the Airport Manager, Little Rock's Airport Certification Manual was approved by the FAA on May 10, 1999. Title 14 CFR 139.205 states that the manual must include "a grid map or other means of identifying locations and terrain features on and around the airport which are significant to emergency operations." The Manager of the Airport Safety and Certification Branch, FAA Office of Airport Safety and Standards, indicated that the airport's Emergency Access Plan (a diagram that shows emergency vehicle access points) was considered by the FAA to be a satisfactory alternative means of identifying locations and terrain features. The access plan was part of the airport's FAA-approved Airport Emergency Plan and was included in the Airport Certification Manual.

1.10.1 Runway 4R/22L Safety Areas

Runway 4R/22L was opened for aircraft operations in September 1991. According to an FAA November 23, 1999, memorandum, runway 4R/22L was built to abate noise over the communities located southeast of the airport. Runway 4R (oriented southwest to northeast) was intended to be used primarily for takeoffs, and runway 22L (oriented northeast to southwest) was intended to be used primarily for landings.

The memorandum detailed the site constraints on the design and construction of the runway, including a flood plain of a creek and rising terrain to the southwest and the flood plain of the Arkansas River to the northeast. The total length available for the runway and its associated safety areas was 8,650 feet. A runway length of 7,200 feet was needed,⁶⁷ so 1,450 feet was available for the safety areas. The runway was designed so that a 1,000-foot safety area extended from the southwest (runway 22L) and a 450-foot safety area extended from the northeast (runway 4R).⁶⁸

The specifications for runway safety areas are contained in 14 CFR 139.309, "Safety Areas," which became effective on January 1, 1988. The specifications state the following:

- (a) To the extent practicable, each certificate holder shall provide and maintain for each runway and taxiway which is available for air carrier use—

⁶⁶ According to 14 CFR 139.315 and 139.317, an ARFF index C facility is to have two or three firefighting vehicles with a total of at least 3,000 gallons of water and aqueous film forming foam. The Little Rock airport has three ARFF vehicles, each with the capacity to carry 1,500 gallons of water and 200 gallons of aqueous film forming foam.

⁶⁷ The FAA's memorandum did not specify how the 7,200-foot length requirement was established.

⁶⁸ The FAA's memorandum stated that accident data indicated that runway overruns during landing are twice as likely to occur than underruns, which explains the decision to place 1,000-foot runway safety area at the southwest end of the runway.

- (1) If the runway or taxiway had a safety area on December 31, 1987, and if no reconstruction or significant expansion of the runway or taxiway was begun on or after January 1, 1988, a safety area of at least the dimensions that existed on December 31, 1987; or
- (2) construction, reconstruction, or significant expansion of the runway or taxiway began on or after January 1, 1988, a safety area which conforms to the dimensions acceptable to the Administrator at the time construction, reconstruction, or expansion began.

Paragraph (c) of this section states that "FAA Advisory Circulars in the 150 series contain standards and procedures for the configuration and maintenance of safety areas acceptable to the Administrator." Table 3-3 in FAA Advisory Circular (AC) 150/5300-13, "Airport Design," dated June 5, 1991, indicates that the runway safety area length should be 1,000 feet.

The FAA's memorandum stated that the Little Rock airport operator was required to comply with Section 139.309(a)(1) because, according to FAA records, five grants for the construction of runway 4R/22L were issued before January 1, 1988 (with the first one in 1982). The memorandum also stated that the runway safety areas for runway 4R/22L met the regulatory requirements.

In July 2001, the Little Rock Airport Manager indicated that the airport was working with the Army Corps of Engineers, the Federal Emergency Management Agency, Pulaski County, and the cities of Little Rock and North Little Rock to extend the runway safety area at the departure end of runway 4R to 1,000 feet. The airport manager also indicated that, if all hydraulic studies and permits are approved, the runway safety area extension could be completed by July 2002.

1.10.2 Runway 22L Approach Lighting System Support Structure

The runway 22L approach lighting system support structure, which is located in a flood plain area of the Arkansas River, is not considered frangible. (The top portion of the structure—its walkway—is considered frangible.) According to AC 150/5300-13, a frangible navigational aid "retains the structural integrity and stiffness up to a designated maximum load, but on impact from a greater load, breaks, distorts, or yields in such a manner as to present the minimum hazard to aircraft."⁶⁹ The FAA's Lead Systems Engineer for Navigation and Landing stated that a structure mounted in a flood plain, such as the runway 22L approach lighting system structure, cannot be frangible because of the possibility of moving water, ice, and floating debris.

The Lead Systems Engineer stated that there are benefits to placing or establishing frangible structures in runway safety areas, citing the November 12, 1995, American Airlines flight 1572 accident in East Granby, Connecticut, as an example. In that accident,

⁶⁹ AC 150/5300-13 indicates that frangible navigational aids include electrical and visual air navigational aids, lights, signs, and associated supporting equipment.

a McDonnell Douglas MD-83 was on final approach, at night and in strong, gusty wind conditions, to runway 15 at Bradley International Airport in Windsor Locks, Connecticut, when it collided with trees. The airplane landed short of the runway and then struck an ILS localizer array (a frangible structure), which properly broke into pieces and thus minimized further damage to the airplane.⁷⁰ The Lead Systems Engineer also indicated that the FAA's effort to replace nonfrangible structures with frangible ones (where appropriate) has been a relatively slow process but that work at about three-fourths of the 450 sites with such structures has been accomplished.⁷¹

1.10.3 Runway 4R Assessments

1.10.3.1 Tire Marks

Tire marks⁷² consistent with those from the left main landing gear began 5,228 feet before the departure end of runway 4R, about 1 foot to the right of the runway's centerline, and continued for 149 feet (5,079 feet before the departure end). Tire marks were not present on the runway's next 207 feet but began again 4,872 feet from the departure end of the runway, about 13 feet to the right of the centerline, and continued until the edge of a gravel downslope located 459 feet beyond the end of the runway. The tire marks were approximately 98 feet to the left of the centerline at the end of the runway surface. Also, the grass to the left of the runway showed tire marks consistent with those from the left main landing gear beginning about 710 feet before the departure end of the runway.

Tire marks consistent with those from the right main landing gear began 4,303 feet before the departure end of runway 4R, about 47 feet to the right of the runway's centerline, and continued until the edge of the gravel downslope located 459 feet beyond the end of the runway. The tire marks were approximately 82 feet to the left of the centerline at the end of the runway surface. In addition, the grass to the left of the runway

⁷⁰ For more information, see National Transportation Safety Board. 1996. *Collision With Trees on Final Approach, American Airlines Flight 1572, McDonnell Douglas MD-83, N566AA, East Granby, Connecticut, November 12, 1995*. Aircraft Accident Report NTSB/AAR-96/05. Washington, DC.

⁷¹ One airport with nonfrangible structures that need to be replaced is Chattanooga Metropolitan Airport, Tennessee. The Safety Board received a copy of a June 3, 1999, letter from the President of the Chattanooga Metropolitan Airport Authority to the FAA Administrator. The letter expressed concern about nonfrangible poles in the airport's runway safety area and cited a 1973 accident involving a DC-9 airplane that struck approach lights mounted on such poles while landing during a thunderstorm. No one was killed in that accident, but the airport authority recognized that the nonfrangible poles were a hazard. The letter further indicated that the approach lighting system was scheduled for replacement but that the date continued to be postponed. The Lead Systems Engineer stated that the replacement lighting system has been delivered by the manufacturer and is in storage but has not yet been installed because of a lack of funding.

⁷² The tire marks were more whitish in color than the surrounding off-white concrete surface. At those points where the tire marks crossed white runway paint markings, the white paint was cleaner and whiter than the surrounding paint. At those points where the tire marks crossed black runway paint markings, the black paint was cleaner and darker than the surrounding paint, and there were no white marks. For information on the relationship between the tire marks and runway friction, see section 1.18.1.

showed tire marks consistent with those from the right main landing gear beginning about 465 feet before the departure end of the runway.

Tire marks consistent with those from the nose gear began 5,079 feet before the departure end of runway 4R, about 6 feet to the right of the runway's centerline, and continued for 207 feet (4,872 feet before the departure end). Tire marks were not present on the runway's next 119 feet but began again 4,753 feet before the departure end of the runway, about 18 feet to the right of the centerline, and continued with occasional interruption until the left edge of the ILS localizer array located 411 feet beyond the end of the runway. The tire marks were approximately 67 feet to the left of the centerline at the end of the runway surface.

Section 1.12.1 contains a photograph showing the tire marks off the end of the runway.

1.10.3.2 Runway Surface Information

The following assessments of runway 4R were made starting the day after the accident:

- A visual inspection revealed several small holes (about 4 inches in diameter) in the pavement on the approach end of runway 4R. Some of the holes had been filled with epoxy. There was evidence of light and medium rubber deposits on the runway surface. No evidence of structural pavement failure was present.
- Friction survey tests, using an Airport Surface Friction Tester, were conducted at 40 to 60 mph in both runway directions. AC 150/5320-12C, "Measurement, Construction, and Maintenance of Skid-Resistant Airport Pavement Surfaces" (dated March 18, 1997), states that the maintenance planning friction levels at 40 and 60 mph are 0.60 and 0.47, respectively. The average friction readings for runway 4R were 0.69 at 40 mph and 0.55 at 60 mph.
- The groove specifications for runway 4R were 1/4-inch deep by 1/4-inch wide and spaced 2 inches apart (center to center). An inspection of selected grooves found that all met the 1/4-inch width and 2-inch spacing specifications. Thirteen panels (19 feet in length) along the full length of runway 4R, including several located by the marks left by the main landing gear tires, were selected for an inspection of groove depth. The average depth was 1/4 inch.
- Field measurements for the runway's transverse slope (from crown to shoulder) averaged 1.42 percent. The construction drawings indicated a transverse slope of 1.5 percent.

- The average surface texture depth measurements for runway 4R were 0.055 inch (clean grooved concrete) and 0.015 inch (clean ungrooved concrete).⁷³ The average surface texture depth for the rubber-coated, grooved touchdown area of runway 4R was 0.050 inch. (The average surface texture depth for the rubber-coated, grooved touchdown area of runway 22L was 0.055 inch.) AC 150/5320-12C states that, when the average texture depth measurement falls below 0.045 inch (the recommended average texture depth for newly constructed pavements), the airport operator should conduct texture depth measurements each time a runway friction survey is conducted. The AC indicates that corrective actions need to be taken when the average texture depth is below 0.030 inch.

In addition, the transverse water flow characteristics of runway 4R were measured by water drainage tests performed on November 16, 1999. The tests involved the release of water from a tanker truck hose onto the centerline of the runway at 100- and 500-foot increments, starting at 5,608 feet before the departure end of the runway (just before the initial left main landing gear tire marks). Dry and wet runway drainage tests were performed, and the winds were calm at the time of the tests.

The test data indicated that the average flow rates from the left to right shoulder edges when the surface was wet were about 10 percent higher than the rates when the surface was dry. Also, a senior research engineer from NASA's Langley Research Center (who was a member of the Airplane Performance Group) determined that, with no winds and the cross (or transverse) slope and surface texture depth values measured after the accident, runway 4R was capable of handling rainfall rates up to 1.4 inches per hour before surface flooding (that is, water depths reaching 0.1 inch and greater) would occur at 15 feet from the centerline. Crosswinds from the left side of the runway, which existed at the time of the accident, would result in deeper water and more flooding on the left side of the runway and shallower water and less flooding on the right side of the runway. The NASA Langley engineer testified that the measurements taken in November 1999 of runway 4R indicated that the cross slope was "very uniform" and provided good drainage of the water from the centerline to the shoulder.

1.10.4 Air Traffic Control Tower Information

The Little Rock ATCT is located on the terminal building and includes a terminal radar approach control (TRACON). The tower cab has positions for cab coordinator, local control-1 and -2, ground control, and flight data. The local control-1 and ground control positions have panels showing readings for the LLWAS system sensors. The local control-1 position also has a Digital Bright Radar Indicator Tower Equipment (D-BRITE) radar display. A System Atlanta Information Display System-4 monitor, located to the right of the flight data position, contains airport-related information and displays hourly and special ASOS observations.

⁷³ The transverse grooves end about 13 feet from the runway's left and right shoulder edges.

ATC radar data are provided by an Airport Surveillance Radar (ASR)-8 sensor located on the airport between runways 4L and 4R. Radar data processing is performed by an Automated Radar Terminal System IIE system that is linked with the TRACON and D-BRITE radar display.

At the time of the accident, the ATCT was operating with midnight shift staffing—one local controller and one controller-in-charge. All approach and tower control positions were combined at the local control-1 position.

The local controller who was handling flight 1420 at the time of the accident was initially certified as a control tower operator in December 1986. The controller served as an air traffic controller for Mather Air Force Base in California for 3 years before beginning work with the FAA. According to his training records, the controller started at the Midway ATCT in Chicago in October 1988 and became a certified professional controller there in June 1990. He transferred to the Little Rock ATCT in November 1992 and has been a certified professional controller there since September 1993. His last medical certification was in October 1997.

On the day of the accident, the local controller had worked the 0600 to 1400 shift. Afterward, he went home, slept for about 4 hours, and returned to the ATCT about 2250 for the 2300 to 0700 shift. He received a position relief briefing from the evening shift controller and then called the TRACON to combine the radar positions in the tower cab. The controller-in-charge was in the TRACON performing administrative duties.

Flight 1420 was the first air carrier operation of the local controller's shift. The controller stated that he first saw the airplane when it was about 1 mile out during final approach and that the landing appeared "normal" and "within the touchdown zone." Because of the reduced visibility, the controller lost sight of the airplane during its rollout. The ATCT transcript indicated that, at 2350:54, the controller requested that flight 1420 report clear of the runway. The controller attempted to contact flight 1420 five more times, between at 2351:16 and 2353:22, and called the ARFF units on the crash phone at 2352:00.⁷⁴ Section 1.15.3 provides information on the emergency response.

The local controller also called the controller-in-charge, asking for his assistance. When the controller-in-charge arrived in the tower cab, the local controller informed him about the possibility of an accident. The ATCT transcript indicated that, about 0003:16, the ARFF units reported that they had located the airplane off the end of the runway. The controller-in-charge then began administrative notification activities. About 0015, the controller-in-charge relieved the local controller, at which time the local controller continued the notification process.

⁷⁴ In a postaccident interview, ARFF personnel indicated that the call on the crash phone was received about 2355—3 minutes later than the controller reported initiating the call. Because the ATC and CVR times could be fairly well correlated, the ARFF response times in this report are based on ATC times.

1.11 Flight Recorders

1.11.1 Cockpit Voice Recorder

The accident airplane was equipped with a Fairchild model A-100A CVR, serial number 53282. The exterior of the CVR showed no evidence of structural damage but was coated with soot. The interior of the CVR and the tape sustained no apparent heat or impact damage.

The CVR was sent to the Safety Board's audio laboratory in Washington D.C., for readout and evaluation. The CVR data started at 2319:44 and continued uninterrupted until 2350:48.1 when electrical power to the CVR ceased. The recording consisted of four channels of "good quality" audio information.⁷⁵ The four channels contained the cockpit area microphone, the captain's audio panel, the first officer's audio panel, and the interphone and public address system. A transcript was prepared of the entire 31-minute 4-second recording (see appendix B).

No sounds that were consistent with the arming or the deployment of the spoilers could be detected on the CVR tape. Two flight tests were conducted on August 27, 1999, to determine whether such sounds could be detected on a CVR recording. Both flight tests were conducted on an American Airlines revenue passenger flight, and both airplanes were MD-82 models equipped with a Fairchild model A100A CVR that was similar to the one installed on the accident airplane. As part of the flight tests, the nonflying pilot verbally confirmed when the spoilers were armed and deployed.

The first flight test was conducted on American flight 1829 from Ronald Reagan Washington National Airport to Chicago-O'Hare. The second flight test was conducted on American flight 154 from Chicago to Washington, D.C. Both tests revealed that the spoiler arming and automatic deployment could be clearly heard on the CVR recordings. In fact, the captain on the second test flight attempted to arm the spoiler handle very slowly to make minimum noise, but a definite "click" sound was recorded on the CVR as the spoiler handle was lifted.

1.11.2 Flight Data Recorder

The accident airplane was equipped with an L3 model FA2100 FDR, serial number 00718. The FDR used solid-state flash memory technology as the recording medium and was configured to digitally record a minimum of 25 hours of operational data before the oldest data were overwritten.

⁷⁵ The Safety Board ranks the quality of CVR recordings in five categories: excellent, good, fair, poor, and unusable. For a recording to be considered good quality, most of the crew conversations need to be accurately and easily understood. The transcript developed from the recording might indicate several words or phrases that were not intelligible; such losses are attributed to minor technical deficiencies or momentary dropouts in the recording system or simultaneous cockpit/radio transmissions that obscure one another.

The FDR was sent to the Safety Board's FDR laboratory in Washington, D.C., for readout and evaluation.⁷⁶ The exterior of the FDR showed evidence of fire and smoke damage. The interior of the FDR showed no signs of damage, and the recording was retrieved from the crash-survivable storage unit. The FDR contained more than 62 hours of data, and American Airlines provided conversion formulas for the data. Examination of the recovered data indicated that the FDR operated normally. Data transcribed included flight 1420's pushback from the gate at Dallas/Fort Worth and the accident airplane's previous landing at Dallas/Fort Worth.

1.12 Wreckage and Impact Information

1.12.1 General Wreckage Description

The Safety Board performed a complete survey of the accident site and airplane structure. The airplane was found approximately 800 feet beyond the departure end of runway 4R. Wreckage was found throughout the flood plain located approximately 15 feet below the runway elevation and down a rock embankment. Wreckage was also found up to 150 feet laterally from the runway 22L approach lighting system and approximately 500 to 850 feet from the end of runway 4R. No fluid markings or airplane components were found on the runway surface.

The fuselage had separated into three main sections (forward, center, and aft). The forward and center fuselage sections were oriented on a magnetic heading of approximately 115°; the rear fuselage section and the empennage were oriented on a magnetic heading of approximately 205°. No evidence of fire damage was found in the forward and center sections of the fuselage, but a postcrash fire had completely consumed the passenger cabin in the rear fuselage section. The left wing was fractured and was completely severed near its root and wing tip. The right wing was found attached to the fuselage. Both engines were attached to their pylons, which were attached to the fuselage. The nose gear and right main landing gear were sheared from their attachments, and the left main landing gear had folded into its main gear wheel well.

The airplane's collision with the approach lighting system crushed the nose of the airplane rearward and destroyed the left side of the fuselage from the airplane's nose to the cockpit's rear bulkhead and from the beginning of the first-class section aft to the second row of the coach section. Large sections of the approach lighting system were intermingled with fuselage structure that had been peeled away from the airplane. The collision with the approach lighting system also created a hole in the left side of the cabin that extended from the overhead stowage bins to the cabin floor in the first-class and coach sections.

⁷⁶ For a listing of the parameters recorded by the FDR, see the FDR Group Chairman's Factual Report in the public docket for this accident. Data from the accident flight and the airplane's previous landings indicated that two parameters—brake pressure left and brake pressure right—were inactive on N215AA.

Figures 12 through 14 are photographs of the airplane wreckage. Figure 12 shows the airplane wreckage, the tire tracks off the end of runway 4R, and the damage to the runway 22L approach lighting system.⁷⁷ Figure 13 shows the airplane wreckage and the runway 22L approach lighting system. Figure 14 shows a closer view of the airplane and the runway 22L approach lighting system. Additional details about the airplane wreckage are presented in sections 1.12.2 through 1.12.4.

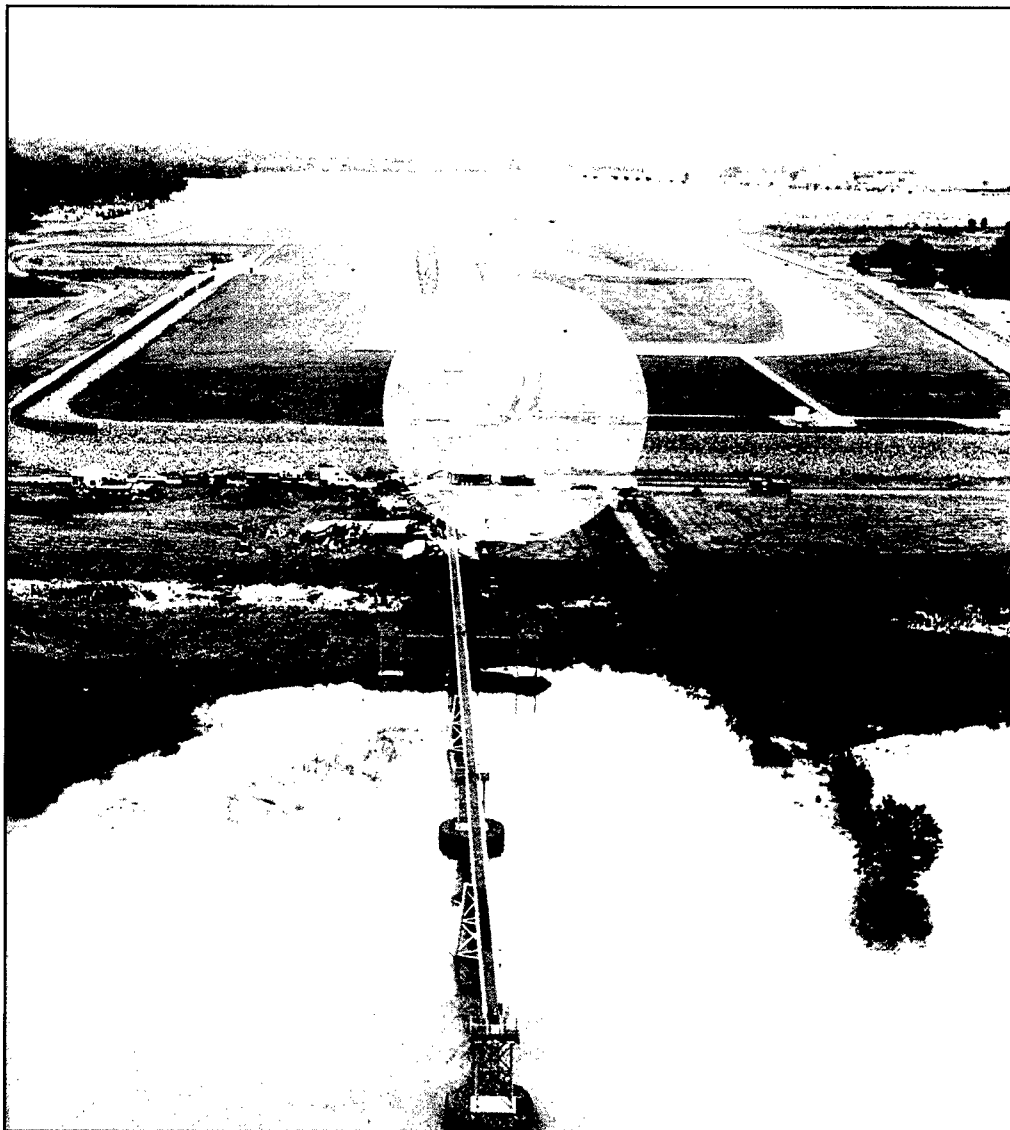

Figure 12. Aerial Photograph of Runway 4R/22L, Airplane Wreckage, and Runway 22L Approach Lighting System

⁷⁷ The runway 22L approach lighting system is supported by steel columns or platform assemblies that include steel columns. Five steel columns and two platform assemblies were struck by the accident airplane during its overrun. Each of these seven support structures was spaced 50 feet apart along a line that coincided with the centerline of runway 4R/22L. The first support structure was located about 530 feet from the end of the runway, and the seventh was located 830 feet from the end of the runway.

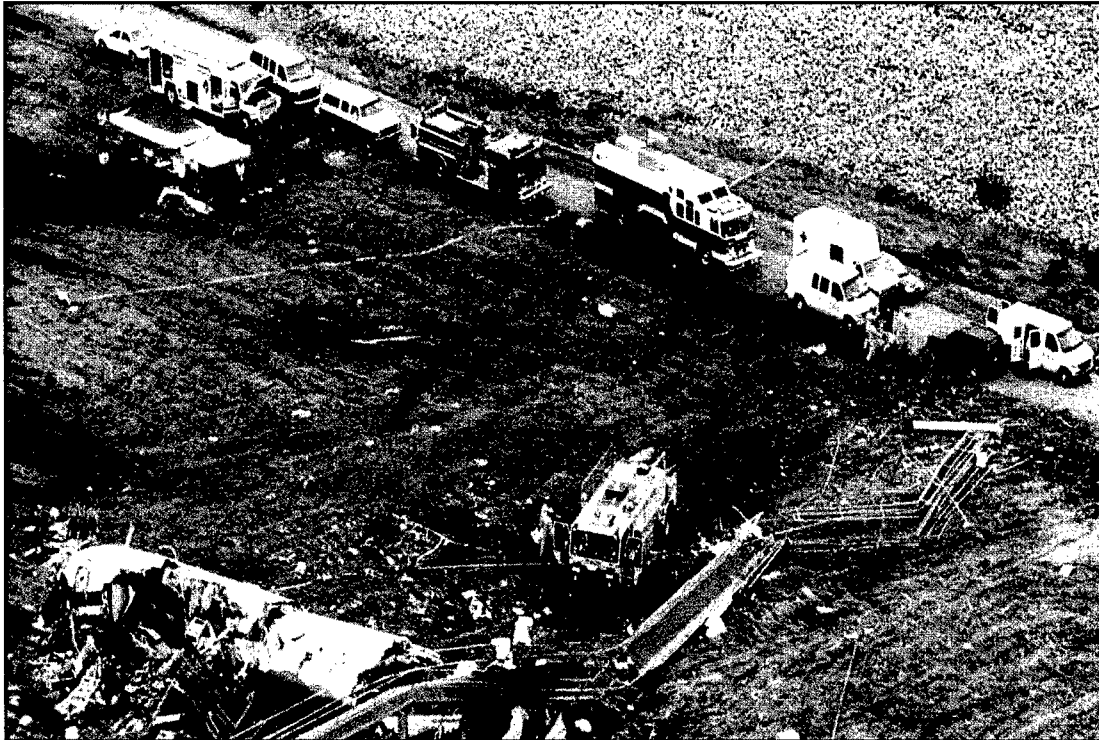

Figure 13. Airplane Wreckage and Runway 22L Approach Lighting System

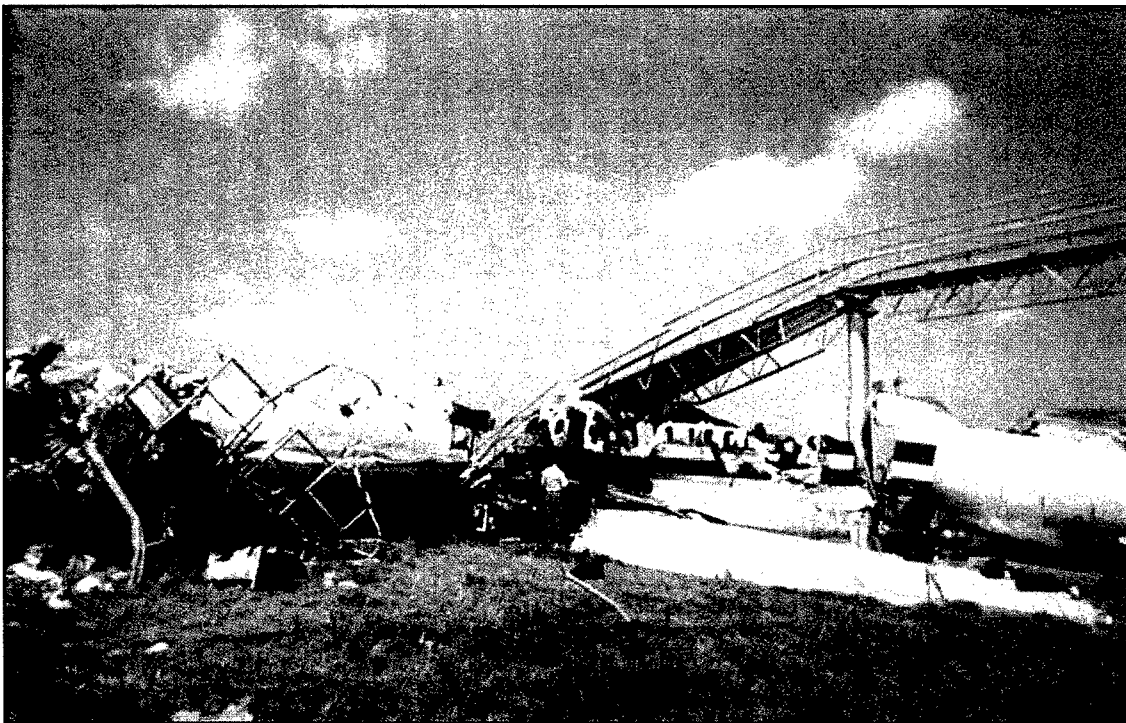

Figure 14. View of Left Side of Airplane Wreckage and Runway 22L Approach Lighting System

1.12.2 Spoiler System

The left flight spoilers and left ground spoiler were found in the retracted position. No damage was noted on either of the flight spoilers. The left ground spoiler panel was fractured inboard of the actuator hinge attachment. The inboard half of the left ground spoiler was heavily sooted on its entire upper surface; no soot was found on the outboard half. The ground spoiler actuator exhibited heat and fire damage and moved freely. The right flight spoilers and right ground spoiler were found in the retracted position. No damage was noted on either of the flight spoilers. The right ground spoiler panel was fractured outboard of the actuator hinge. The mechanical overcenter link was latched.

The cockpit center pedestal had considerable displacement and deformation in the left downward direction. The spoiler handle was found fully aft. About one-half of the autospoiler system ARM red indicator stripe was visible, and the handle guide was resting on the pedestal surface.

Tests performed on the accident airplane's spoiler system are discussed in section 1.16.1.

1.12.3 Engines

Both engines showed no evidence of any uncontainments, case ruptures, or precrash fires. The engines' low pressure rotors rotated freely, and the fan blades had minor impact damage on the leading edges of the airfoils. The left engine thrust reverser was partially deployed, and the right engine's thrust reverser was completely stowed. The left engine's fuel control was in the reverse thrust range, and the right engine's fuel control was in the forward thrust range.

On June 8, 1999, the two engines, thrust reversers, and EPR transmitters were examined and tested at American Airlines Maintenance and Engineering Center. The engines were able to produce normal-rated takeoff thrust without exceeding operating limitations. The thrust reversers were able to cycle from the stowed-to-deployed and deployed-to-stowed positions. The EPR transmitters were found to function normally.

1.12.4 Landing Gear and Brake Assemblies

The left main landing gear was lodged into its wheel well, and the wheel assembly was oriented 90° clockwise from its normal position. The outboard (No. 1) and inboard (No. 2) tires were found deflated and exhibited deformation. Both tires had large cuts and lacerations on the tread surface and sidewalls. The tread depths for the No. 1 and 2 tires ranged from 0.156 to 0.250 inch. No flat spots were present on either of the tires.⁷⁸

⁷⁸ According to Michelin Aircraft Tire Corporation (the manufacturer of the accident airplane's tires), flat spots result from skidding without tire rotation, for example, during brake lockup.

The right main landing gear and its rear spar attachment fitting was found separated from the rear spar and aft of the right inboard wing. The inboard tire (No. 3) was found deflated, and the outboard tire (No. 4) was found pressurized at about 195 psi (unloaded). The tires had large cuts and lacerations on both the tread surfaces and sidewalls. The tread depths for the No. 3 and 4 tires ranged from 0.094 to 0.313 inch. No flat spots were present on either of the tires.

The nose gear strut and wheel assembly were found protruding from beneath the right side of the fuselage belly. Both tires were found deflated, and both inboard wheel halves were cracked. The tread depths for the left and right tires ranged from 0.125 to 0.188 inch. The nose-wheel steering cylinders were found in the debris field with both their pistons extended almost equal amounts.

The left main landing gear brake assemblies showed no evidence of overheat damage but showed evidence of impact damage. The No. 1 brake had approximately 1 inch of wear pin remaining, and the No. 2 brake had 11/16 inch of wear pin remaining. The right main landing gear brake assemblies showed no evidence of impact or overheat damage. The No. 3 brake had approximately 3/4 inch of wear pin remaining, and the No. 4 brake had about 1 inch of wear pin remaining.

The antiskid control box was tested at Crane Hydro-Aire (the manufacturer), Burbank, California, on August 3, 1999. The control box passed all functional tests described in the manufacturer's TP42-807 test procedure. Tests performed on the accident airplane's main landing gear tires are discussed in section 1.16.2.

1.13 Medical and Pathological Information

According to the Pulaski County Coroner, the captain and the passengers in seats 3A, 8A, 17B, 18A, and 18B died as a result of traumatic injuries, and the passengers in seats 19A, 19B, 19D, 27E, and 28D died from smoke and soot inhalation and/or thermal injuries. Two of the passengers (seats 8A and 28D), died on June 10 and June 16, 1999, respectively.⁷⁹

Tissue and fluid specimens from the captain were transported to the FAA's Civil Aerospace Medical Institute (CAMI) in Oklahoma City, Oklahoma, for toxicological analysis. The CAMI laboratory performed its routine analysis for major drugs of abuse and prescription and over-the-counter medications, and the results were negative. The analysis detected no ethanol in the captain's blood and tissue specimens.

American Airlines' Area Medical Director indicated in a September 1, 1999, letter to the Safety Board that postaccident drug testing was not performed on the first officer because of his medical condition after the accident and his inability (because of sedation) to comprehend the documentation requiring knowledge and consent. The letter also stated

⁷⁹ According to 14 CFR 830.2, fatalities that occur within 30 days after an accident are to be included in the total number of fatal injuries.

that a representative of the FAA's Office of Drug Testing agreed with the decision not to test the first officer.

1.14 Fire

A fuel-fed fire erupted between the center and aft fuselage sections after the impact sequence. The fire spread and eventually consumed the interior of the aft fuselage section. The ARFF trucks arrived at the accident scene about 0008. The firefighters applied water and aqueous film forming foam to the fire and extinguished the exterior fire within 60 seconds. Firefighters then suppressed smaller fires, including one under the left wing, by applying aqueous film forming foam for another hour. The Safety Board's investigation revealed no evidence of an in-flight fire.

1.15 Survival Aspects

1.15.1 General

The accident airplane's interior was original equipment installed in 1983. The airplane was configured with 139 passenger seats, 14 in first class and 125 in coach class. The cockpit contained two flight crew seats and one observer seat. An aft-facing, double-occupancy flight attendant jumpseat was located by the 1L exit door; an aft-facing, single-occupancy flight attendant jumpseat was located by the 2L exit door; and a forward-facing, double-occupancy flight attendant jumpseat was mounted on the tailcone exit door. Figure 15 shows the interior airplane configuration and the injuries sustained by the passengers and crewmembers according to seat location.

The airplane was equipped with an overhead emergency lighting system and a floor proximity escape path lighting system. The wiring and lamps on both systems forward of row 17 were tested after the accident using an alternate electrical power source. All undamaged lamps in both systems operated normally.⁸⁰ The remaining battery packs and control units from both systems were tested at American Airlines facilities in Dallas according to the manufacturers' test procedures. All of the batteries and control units performed as designed.

⁸⁰ Some ARFF and Metropolitan Emergency Medical Service (MEMS) personnel reported that they found the cabin floor lights illuminated.

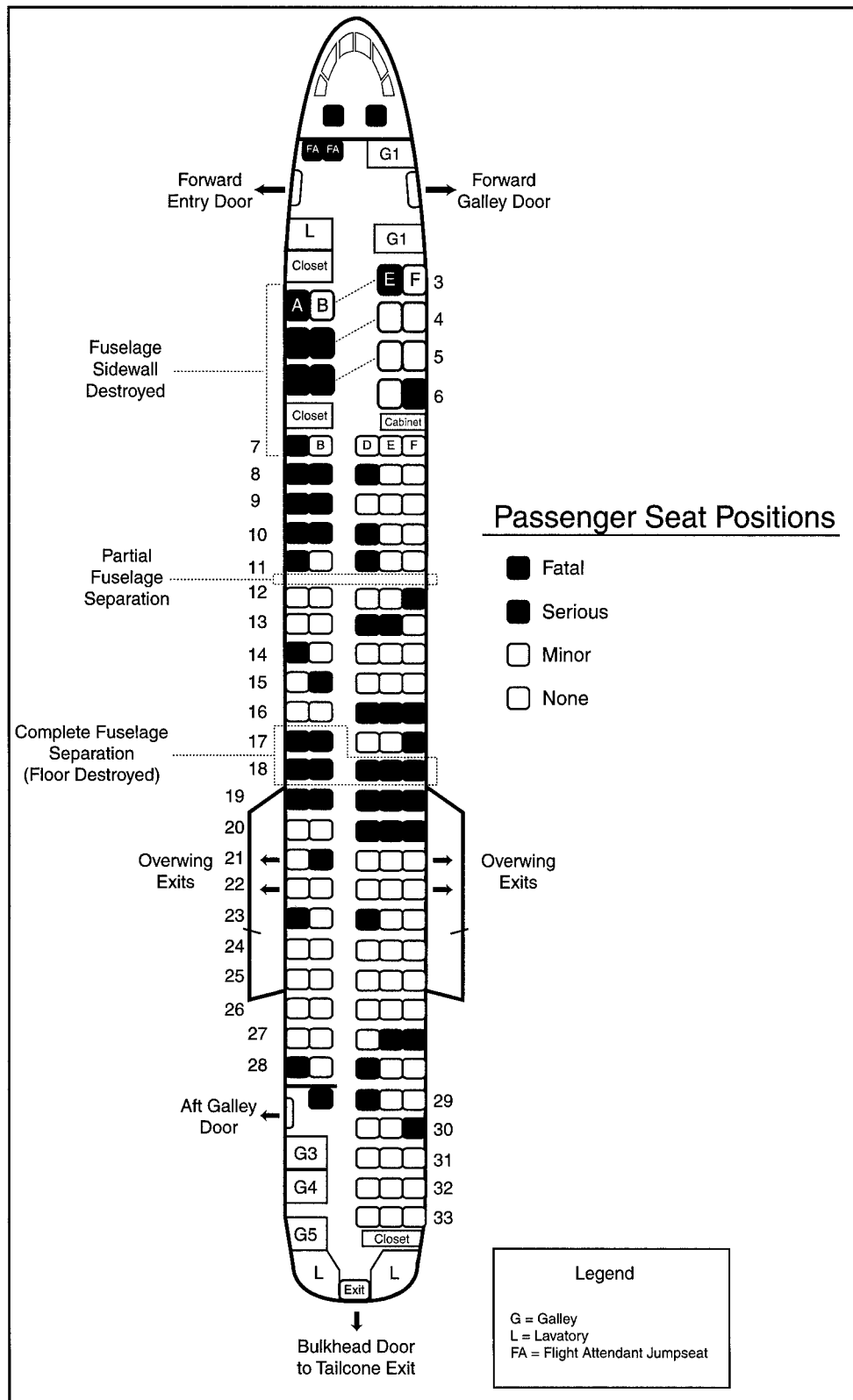

Figure 15. Interior Airplane Configuration and Occupant Injuries

1.15.2 Evacuation of Passengers and Crewmembers

The first officer could not evacuate the airplane on his own because his left femur had been fractured during the accident sequence. He was removed from the airplane wreckage by rescue workers, who had to cut through metal and step on the center pedestal to extricate him.⁸¹ The on-scene commander indicated that rescue workers also had to remove some surviving passengers from the first-class section. The flight attendants seated on the forward jumpseat were seriously injured in the crash and could not assist with passenger evacuations. The flight attendants in the aft cabin were able to assist with passenger evacuations.

Passengers that were forward of the fuselage separation at row 18 escaped through a large hole on the left side of the first-class section and through a separation in the fuselage at row 12. The forward entrance (1L) and forward galley (1R) doors could not be used because of structural deformation of the fuselage. Six passengers seated on the left side of the first class section (seats 3A and B, 4A and B, and 5A and B) were ejected in their seats through the large hole. (Five of these six passengers survived.) The flight attendant seated on the inboard forward jumpseat was carried out of the airplane by a passenger through the large hole in first class. The flight attendant seated on the outboard forward jumpseat also left the airplane through the large hole in the first-class section.

Seven passengers (seated in 17A and B, 18A and B, and 18D through F) were ejected in their seats into the area between the fuselage sections—aft of row 16 on the left, aft of row 17 on the right, and forward of row 19. (Four of these seven passengers survived.) One passenger reportedly exited the airplane at the fuselage break aft of row 17 on the right side. Two passengers exited the airplane through the fuselage separation directly forward of row 19.

All four overwing emergency exits were opened by passengers from inside the cabin. Several passengers who were seated aft of row 19 and forward of row 29 used three of the four overwing emergency exits to escape. The passengers seated next to the left and right forward overwing exits reported that they had trouble opening the respective doors but that someone else was able to open these doors. A fire was outside of the left forward overwing exit, and no passengers reported or were observed escaping the airplane through that exit. Four passengers used the right forward overwing exit to escape. The passenger seated next to the left aft overwing exit was able to open the hatch, reporting that the door “seemed to pop out easily and quickly.” The passenger seated next to the right aft overwing exit initially had trouble opening the hatch but was able to get it open. Four passengers used the left aft overwing exit to escape, and at least 26 passengers used the right aft overwing exit.

⁸¹ Because emergency personnel had to step on the center pedestal to extricate the first officer from the wreckage, the documented positions of cockpit instruments after the accident might not indicate their positions at the time of the accident. In addition, the emergency personnel indicated that they had turned switches off when they went through the airplane.

The aft galley (2L) door could not be used because of impact damage from the runway 22L approach lighting system. The flight attendant seated in the aft galley jumpseat and four passengers used the gap between the fuselage and the top of the door to escape.

The flight attendant seated in the aft cabin jumpseat opened the aft bulkhead door (leading to the tail cone exit) with the assistance of passengers. The flight attendant and several passengers entered the tail cone area, but the tail cone did not fall away from the airplane after the flight attendant and at least one passenger pulled the release handle. The flight attendant and passengers then kicked and jumped on the tail cone and created a gap between the fuselage and the tail cone that 12 people used to escape from the airplane.

1.15.3 Emergency Response

As discussed in section 1.10.4, the local controller indicated that he called the ARFF units on the crash phone about 2352. According to ARFF personnel, the controller stated that an American Airlines airplane was down on runway 4R but did not specify the approach or departure end of the runway. The ARFF station responded with all available assets—four firefighters (including a fire captain) and three fire trucks.⁸² The driver of fire truck No. 2 indicated that the fire trucks had departed the station within 1 minute of the local controller's call. The driver of fire truck No. 3 reported that he drove into "blinding rain and wind."

All three fire trucks proceeded toward the approach end of runway 4R. (The Little Rock Fire Department District Chief testified at the Safety Board's public hearing that all three units went in the same direction because they were trained to work as a team.) ARFF personnel indicated that the trucks proceeded slowly (estimated at 15 to 20 mph) because of the restricted visibility (estimated to be about 100 feet) and unknown location of the airplane. The fire captain notified Little Rock Central Communications about 2355 that ARFF vehicles were responding to the report of an American Airlines airplane down on runway 4R.

The ATCT transcript indicated that, at 0000:11, fire truck No. 2 indicated that the airplane was not at the approach end of runway 4R and asked the controller whether the fire trucks should "sweep the runway." Five seconds later, the controller stated that the airplane was at the departure end of the runway and cleared the fire trucks to proceed in

⁸² Title 14 CFR 139.319(j) requires that "sufficient rescue and firefighting personnel are available during all air carrier operations to operate the vehicles, meet the response times, and meet the minimum agent discharge rates required by this part."

the other direction.⁸³ The ATCT transcript also indicated that, at 0001:08, the controller informed fire truck no. 2 that “I saw him [the airplane] as he went past midfield.”

In postaccident interviews, the firefighters indicated that visibility improved once past the midfield point on their way to the departure end of runway 4R. Fire truck no. 2 indicated that it experienced sliding on the pavement and noted airplane tire tracks leaving the runway surface and a missing runway light. When the trucks arrived at the “22L” painted on the runway, ARFF personnel saw a glow and blowing smoke. The ATCT transcript indicated that, at 0003:16, fire truck No. 1 reported that the airplane was off the end of the runway and on fire and stated “this is an alert three” twice.⁸⁴ The fire captain informed Little Rock Central Communications of the alert 3 status and indicated that the airplane was off the northern end of runway 4R outside of the airport. The fire captain requested a “full response” from Central Communications.

The fire trucks were unable to proceed directly to the airplane because of the slope at the end of the runway. As a result, the trucks had to travel in the opposite direction to an access road and then turn onto a perimeter road back in the direction of the accident site. The fire captain and another firefighter indicated that they had to stop to open a locked perimeter security gate, which took about 20 seconds, before continuing on the perimeter road to the accident site. The three ARFF vehicles reached the accident scene about 0008, and firefighters began extinguishing the fire immediately upon arrival.⁸⁵

The Little Rock Fire Department District Chief was monitoring his radios at Central Communications when he overheard a report from fire truck No. 2 that the tower had lost communication with an American Airlines airplane. The district chief advised Central Communications that he would report to the accident scene as the on-scene commander. The chief arrived on scene and assumed command from the fire captain, who had set up a command post by that time. The chief reported that most of the fire had been put out by the time he arrived on scene. The district chief testified that the rain helped to extinguish the fire and keep it abated. The chief also testified off-airport help began arriving on scene about 2 to 3 minutes after the ARFF units had arrived.

Metropolitan Emergency Medical Services (MEMS) records indicated that dispatch received notification of the alert 3 status about 0005 from an off-duty dispatcher who overheard ARFF radio transmissions on his scanner.⁸⁶ MEMS dispatch confirmed the

⁸³ The Little Rock Fire Department Chief testified at the public hearing on this accident that the standard phraseology between the fire department and the control tower regarding the location of an airplane normally involves runway and taxiway numbers. He indicated that, when the controller stated that an airplane was down on runway 4R, the firefighters assumed that the airplane was located at the approach end. The chief further indicated that, if the controller had known that the airplane was at the departure end of runway 4R, he would have “more than likely” told the rescue personnel to go to runway 22L.

⁸⁴ “Alert 3” is defined in the Airport Emergency Plan as an aircraft accident that has occurred on or in the vicinity of the airport. It is the most serious of the airport’s three alert categories.

⁸⁵ The district chief stated that ARFF personnel’s first priority is fire control so that an escape path can be provided. The chief also stated that, once the fire is controlled, ARFF personnel can assume rescue responsibilities and begin treating victims.

alert 3 status with Little Rock Central Communications about 0006, and dispatch contacted the MEMS supervisor about 0008. Central communications informed MEMS about 0011 that an American Airlines airplane was down and that "a big response" was needed. The MEMS supervisor departed for the accident site about 0012. The supervisor arrived in the accident area about 0017 but could not report on scene because he encountered a locked gate adjacent to the airport's United Parcel Service facility. He contacted the on-scene commander by radio and was directed to an open gate.

The MEMS supervisor reported on scene about 0022 and set up a triage area. A MEMS unit (comprising two emergency medical technicians and a paramedic) arrived 2 minutes later and began triage activities. Another MEMS unit arrived on scene afterward and continued triage activities. Some ambulatory survivors were transported on a bus to a fire station before MEMS personnel could assess them, so a separate triage area was established at the fire station.

The Little Rock Fire Department District Chief indicated that, to check for passengers and crewmembers after the accident, firefighters went inside the airplane and did "line abreast searches" about 50 to 100 feet on each side of the airplane and from the airplane to the Arkansas River. The district chief also indicated that, to be sure that everyone was accounted for, the firefighters repeated this process once daybreak occurred.

The Little Rock Fire Department reported that 13 engine companies, one ladder company, 1 heavy rescue unit, 1 hazardous materials unit, and 9 staff vehicles were involved during the peak of the emergency response. MEMS estimated that 19 ambulances and a number of other medical support or supply vehicles participated in the emergency response. Also, a medical helicopter made two flights to local hospitals, transporting four people. Survivors of the crash were taken to Arkansas Children's Hospital, Arkansas Heart Hospital, Baptist Medical Center, Baptist Memorial Medical Center, Southwest Regional Medical Center, St. Vincent Hospital, and the University of Arkansas Medical Center.

The Little Rock Fire Department Chief testified that, since the accident, six more ARFF personnel were hired and that the number of personnel for each shift increased to six. He also indicated that the fire department has looked into getting a Driver's Enhanced Vision System (DEVS). (See section 1.18.4 for information about this system.)

At the time of the public hearing on this accident, Little Rock National Airport had not conducted a formal debriefing with all of the parties involved in the emergency response on the night of the accident. In July 2001, the Little Rock Airport Manager stated that the airport conducted individual critiques in February and March 2000 with the Little Rock Fire Department, the Little Rock ATCT, the Little Rock Office of Emergency Services, airlines that fly into the airport, MEMS, and the Little Rock Police Department.

⁸⁶ The Little Rock Fire Department indicated that its recorded times were ahead of MEMS times by 2 minutes 46 seconds. Because the fire department's times appeared to correlate with the original ARFF times, which were adjusted back by about 3 minutes to correlate with ATC times, no time adjustments were necessary for MEMS times.

According to the airport manager, the purpose of these critiques was to review the airport's emergency plan. The airport manager also indicated that the airport conducted a group critique on March 15, 2000. All of the emergency response agencies were invited to attend and provide comments. Present at the group critique were representatives from the airport, the Little Rock ATCT, FAA Flight Standards District Office, six airlines, and three local hospitals. The agenda for the group critique indicated various issues to be discussed, including communications, access to an accident site, triage and treatment areas, grid map parameters, and water rescue capabilities. The Deputy Airport Manager sent a memorandum, dated March 16, 2000, to the emergency response agencies and group critique participants. The memorandum documented the recommendations, observations, and concerns that the hospital representatives expressed during the group critique.

1.15.4 Passenger Statements

The Safety Board interviewed 56 surviving passengers in person or by telephone after the accident. Also, the Board sent questionnaires to all 129 surviving passengers, and 110 questionnaires were returned.

Passengers reported that the flight was bumpy and that a pilot had announced over the public address system the possibility of some rough weather. Passengers also stated that they saw lightning outside the airplane during the final descent and that a pilot had indicated over the public address system that there was a "light show" outside the airplane. Passengers reported that the rain became harder, and some passengers described turbulence and hail, as the final descent continued.

Passengers reported that the touchdown was very hard and that the airplane did not slow down. One passenger indicated that the wheels were "shuddering." Another passenger stated that he heard a sound similar to car brakes and that the airplane "fishtailed." Other passengers indicated that they heard the thrust reversers come on and off. Passengers also reported that the flight attendants yelled "brace" to prepare for the impending impact.

Passengers indicated that most people evacuated the airplane in an orderly manner (although there were a few reports of passengers pushing or jumping over others) and that some passengers helped others get out of the airplane and away from the wreckage. Passengers also indicated that the fire did not enter the aft fuselage interior until after the passengers had evacuated from that part of the cabin but that smoke entered the aft cabin immediately after the fire began. Passengers further indicated that, once outside the airplane, they encountered heavy rain, strong winds, and hail. Some passengers reported huddling in groups, and others reported sheltering themselves from the weather with bales of hay in a field, until emergency workers arrived.

Two passengers reported information regarding the passenger in seat 27E (a 21-year-old male), who was killed in the accident. The passenger in seat 21D indicated in a postaccident interview that, when the back of the airplane had apparently cleared of passengers, he stuck his head inside the cabin, through the right aft overwing exit, and

yelled, "is anybody else in there?" three times, to which someone answered, "that's everyone—that's all." The passenger in seat 21D identified the voice inside the airplane as that of the passenger in seat 27E. (The passenger in seat 21D was the director of a church choir group, and the passenger in seat 27E was a member of the group.) In addition, the passenger in seat 27D stated in a postaccident interview that he saw the passenger in seat 27E "scoot" toward the aisle and stand up after the crash. The body of the passenger from seat 27E was found in the area by rows 32 and 33.

1.16 Tests and Research

1.16.1 Spoiler System Ground Tests

To better understand MD-80 spoiler system operation, the Safety Board, while on scene in Little Rock, requested that American conduct ground tests on an MD-82 airplane similar to the accident airplane. These tests, which were conducted at American Airlines' Maintenance and Engineering Center in Tulsa, Oklahoma, included verification of the maximum spoiler deflection with a full right roll input and the response of the system to the spoiler autoretract mechanism. These tests were intended to assist the Board in gathering on-scene evidence; as a result, the tests were not witnessed by the Board, and the test data were not recorded by American. After a subsequent incident at Palm Springs, California, involving an American Airlines MD-80 series airplane that did not experience autospoiler extension at touchdown, the tests were repeated and additional tests were conducted so that spoiler panel positions could be recorded and CVR and FDR data could be obtained. These tests and the Palm Springs incident are discussed further in section 1.16.1.1.

Other tests conducted on the accident airplane's spoiler system were as follows:

- The autospoiler switching unit and ground spoiler control box were tested at American Airlines' Maintenance and Engineering Center on July 1, 1999. Both passed functional tests. The tests were done in accordance with American Airlines Engineering Specification Order 80503 functional test procedures chapter 10 and American's Engineering Specification Order 80340 functional test procedure chapter 8.
- The two ground control nose oleo switches were tested at the Safety Board's laboratory in Washington, D.C., on July 10, 1999. Both switches operated smoothly, and electrical continuity was verified in the air (open) and ground (closed) switch positions.
- The center pedestal was examined at the Safety Board's laboratory on July 15, 1999. No significant marks were found on the spoiler control handle or handle slot that would indicate the handle's position at impact. The autospoiler crank arm was found in the extended position and above the roller on the handle. The

left throttle autoretract crank was measured to be 1 3/4 inches from the idle stop. No evidence of preexisting failures was found on any center pedestal switch or control.

- The autospoiler actuator was examined at Telair International (the manufacturer of the actuator), Oxnard, California, on August 6, 1999, and at the Safety Board's laboratory. The actuator had sustained impact damage. Members of the Systems Group who participated in the teardown agreed that the actuator was most likely capable of functioning within its operational parameters.⁸⁷ During the disassembly, the wire to the direct current brake was found broken, and the brake plate was found to have excessive wear.⁸⁸

1.16.1.1 Testing Conducted After the Palm Springs Incident

On February 16, 2000, about 0708 Pacific standard time, American Airlines flight 9503, an MD-83, N597AA, departed the left edge of runway 13R while landing at Palm Springs International Airport, Palm Springs, California. The airplane was on a positioning flight from Los Angeles International Airport to Palm Springs. The captain and first officer were not injured, and the airplane received minor damage.⁸⁹ Tests on the Palm Springs incident airplane were initially conducted at American Airlines' Maintenance and Engineering Facility on August 24, 2000, but were repeated on October 12, 2000, because of a problem with data recording. The tests and their results are as follows:

- **Spoiler knockdown:** The spoilers were extended, and the left throttle was advanced until the spoiler handle automatically retracted. The spoiler handle was observed to slowly depress until the point at which it was knocked down and automatically retracted. The throttle was measured to be 1 3/4 inches above idle.
- **Touchdown retract:** The crank arm on the left throttle knocked down the spoiler handle when the throttle was advanced about 1 3/8 inch above idle (about 1.16 EPR) before the handle was extended. Six of these "handle knockdown" operations were conducted; for each operation, the FDR recorded an input for both spoiler positions. The recorded left outboard flight spoiler positions ranged from 1.0° and 9.8°, and the recorded right inboard flight spoiler positions ranged from 1.3° and 10.5°. (The recorded positions depended on when the sample was taken in relation to spoiler extension.) The right spoiler panels were observed during some of the operations. The Systems Group estimated that the right flight spoilers extended to about 8° to 10° before

⁸⁷ The actuator passed all functional tests except one. The actuator failed to operate when it was positioned at mid-stroke, a weight was attached to the arm, and a reduced voltage was applied. This failure was not significant to the overall outcome of the testing.

⁸⁸ Because of the successful brake test and the characteristics of the damage to the wire, the Systems Group determined that the damage to the wire occurred most likely during the accident sequence and that the wire was completely separated during the disassembly.

⁸⁹ The description for this incident, DCA001A027, can be found on the Safety Board's Web site at <<http://www.nts.gov>>.

immediately retracting. The time interval for the spoiler panels to extend and then immediately retract was about 1/2 second. The ground spoilers did not move.

- **Autospoiler extension with roll inputs:** Normal autospoiler extensions were conducted with full left and right roll inputs.
- **Engine response:** The throttles were quickly advanced from idle to between 1 3/8 and 1 3/4 inches and then immediately retracted. When the engines were at ground idle, no movement of any engine parameters could be seen in the cockpit. When the engines were at flight idle, a momentary movement of the EPR and N1 indicators was seen in the cockpit.

The CVR was running continuously throughout the tests, and the cockpit door was closed during portions of the tests to better replicate in-flight sounds. Recordings were made of the autospoiler actuator operating with the spoiler handle in the armed position, the left throttle at 1 3/4 inches above idle and at idle, and the spoiler handle in the unarmed position. The CVR also recorded the sounds associated with arming and unarming of the spoiler handle.

1.16.2 Main Landing Gear Tire Examination

All four main landing gear tires from the Little Rock accident airplane were inspected at the Michelin Aircraft Tire Corporation, Greenville, South Carolina, on October 10, 2000. The entire tread surface (internal and external) of each tire was inspected, and all four tires exhibited typical wear characteristics for bias-ply tires and were estimated to be about 50 percent worn. None of the tires showed any evidence of external reverted rubber or internal ply separation. Superficial scrub marks were found laterally on the tread surface. The tires' inner liners showed no evidence of underinflation or excessive load.

To determine whether the tires had been heated because of reverted rubber hydroplaning,⁹⁰ Shore hardness tests were performed using a device, known as a durometer, to measure the hardness of the rubber in the tires. (Reverted rubber hydroplaning tends to soften the rubber on the tires.) Durometer measurements were taken every 90° on the tread surface, and all readings were within the tires' expected operating range. Michelin engineers believed that storage length and conditions would have had

⁹⁰ An article, titled "Landing on Slippery Runways," in Boeing's October to December 1992 *Airliner* magazine, explained reverted rubber hydroplaning as follows: "when a tire locks up on a smooth, wet, or icy surface, the friction heat generates steam. The steam pressure then lifts the tire off the runway, and the steam heat reverts the rubber to a black gummy deposit."

only minor effects on the hardness readings and would not have affected reverted rubber if it were present.⁹¹

At the request of investigators, Michelin conducted a more extensive measurement of tire tread hardness by taking measurements every 10° on all four tire ribs. These measurements confirmed that the hardness of each tire was within operational standards.⁹² Further tests (holographic imaging and sectional, rubber, and microscopic analyses) were considered but not performed because they would not provide any additional data on whether reverted rubber hydroplaning occurred during the accident sequence.

Michelin engineers presented information on reverted rubber hydroplaning and the conditions that cause internal reverted rubber. The engineers stated that reverted rubber hydroplaning, which occurs on the molecular level on the surface of the tire tread, happens very quickly and does not cause internal heating of the rubber because of its very low thermal conductivity. The engineers indicated that evidence of reverted rubber hydroplaning could be worn away fairly quickly. The engineers further indicated that, for internal heating of the tires to occur, the tires must have a significant load and be rolling for a substantial distance and that damage from internal heating could accumulate over time.

1.16.3 Cockpit Voice Recorder Sound Spectrum Study

To determine whether the autospoiler actuator operated at touchdown, the Safety Board conducted a CVR sound spectrum study at its headquarters in Washington, D.C. The sound spectrums from the CVRs aboard the Little Rock accident airplane, Palm Springs incident airplane, flight test airplanes, and ground test airplane were examined on a spectrum analyzer, which gives a visual presentation of the frequency contents of signals, and a computer signal analyzer, which presents the specific frequency content of the signals and detailed timing and waveform information. Charts were prepared for all of the airplanes to document the sounds heard on the cockpit area microphone.

The sound spectrum study indicated that most of the noise made by the autospoiler actuator was at a frequency centered around 1200 hertz (Hz). For the Little Rock accident airplane, the sound associated with the autospoiler actuator lasted about 0.08 second. A “clunk” sound was heard about 0.32 second after the initial actuator sound. For the Palm Springs incident airplane, the sound associated with the autospoiler actuator lasted 0.06 second, and the “clunk” sound was heard 0.30 second after the initial actuator sound.

The sound spectrums were compared with those from the flight and ground tests. As stated in section 1.11.1, the flight tests were conducted in August 1999 aboard two American Airlines flights. The flight crews armed the autospoiler handle during approach

⁹¹ The tires had been in storage for more than 1 year in a hangar that was not environmentally controlled.

⁹² Two of the tires had localized soft spots, which were associated with tread contamination or rib damage as a result of the impact sequence.

and conducted a normal touchdown, upon which the wheel spin-up sensors triggered the motor to automatically deploy the spoiler handle. For the first flight test airplane, the sound associated with the autospoiler actuator lasted 0.18 second, and the “clunk” sound was heard 0.30 second after the initial actuator sound. For the second flight test airplane, the sound associated with the autospoiler actuator lasted 0.19 second, and the “clunk” sound was heard 0.32 second after the initial actuator sound.

As stated in section 1.16.1.1, the ground tests were conducted in August and October 2000 aboard the Palm Springs incident airplane. The CVR was run continuously during the tests, and several autospoiler actuator sequences were analyzed. For the test that triggered the autospoiler system with the spoiler handle in the unarmed position, the sound associated with the autospoiler actuator lasted about 0.06 second, and the “clunk” sound was heard 0.18 second after the initial actuator sound. For the test that involved the autospoiler system with an armed spoiler handle, two actuator sequences were analyzed. For both sequences, the sounds associated with the autospoiler actuator lasted 0.16 second, and the “clunk” sounds were heard 0.30 second after the initial actuator sounds.

1.16.4 Airplane Performance Study

An Airplane Performance Study was conducted to determine the motion of American Airlines flight 1420 and the physical forces that produced that motion. The study considered data from the following sources: wreckage location, runway scars and markings, radar data, FDR and CVR data, weather information, and ground deceleration computer program results. The radar, CVR, and FDR data times were synchronized to a single reference time.

The airplane performance parameters that were of primary interest in this accident were those that defined the motion of the airplane on the runway, including the airplane’s position; ground speed; heading, track, and drift angles; and deceleration. The approach parameters of primary interest included the airplane’s position relative to the ILS localizer and glideslope beams; airspeed; heading, bank, pitch, drift, and flightpath angles; and the rate of climb or descent. The control inputs, power settings, and winds that affected the airplane were also important considerations during the approach and landing segments.

The FDR and radar data were used together, along with weather information, runway tire markings, and wreckage location, to calculate the airplane’s flightpath. The position of the airplane was determined in two different segments: the “in air” trajectory, which incorporated data from 440 to 20 feet afl, and the “on ground” trajectory, which incorporated data from 20 feet afl to about 600 feet beyond the end of runway 4R (at which point the FDR ceased to record data). The calculated ground trajectory is discussed further in section 1.16.4.1.

The altimeter setting reported by air traffic controllers during flight 1420’s approach to the airport was 29.86 inches of Hg. The Airplane Performance Study indicated that, because the atmospheric pressure was rising rapidly during the descent and

landing, an altimeter setting of 29.92 inches of Hg would have been more accurate for the final approach segment of the flight.⁹³ An altimeter setting of 29.86 inches of Hg would have resulted in an indicated altitude that was about 55 feet lower than the altitude with an altimeter setting of 29.92 inches of Hg. (After the accident, the altimeter setting for the airport was recorded as 29.98 inches of Hg.)

1.16.4.1 Calculated Ground Trajectory

On final approach, the accident airplane's airspeed averaged 156 knots, which was about 25 knots faster than the V_{ref} , and jumped erratically within a band of ± 5 knots, which was consistent with the gusty and turbulent winds on approach.⁹⁴ The wind was blowing mostly along the airplane's lateral axis, from the left to the right sides of the airplane. The airplane touched down 2,000 feet from the runway threshold at a ground speed of 160 knots, drifting about 5° to the right,⁹⁵ and a tailwind component of about 5 knots was present. A ground speed of 160 knots was about 20 knots faster than the zero-wind touchdown ground speed that would result from an approach at the reference airspeed plus 10 knots.

Flight 1420 continued to drift while on the runway by as much as 16° both to the right and the left of the direction of travel. Just before the FDR data ended, the airplane's heading was 20° to the right of the direction of travel. The airplane was returning to the extended centerline of the runway when it impacted the runway 22L approach lighting system support structure.

From 3,000 to 5,800 feet beyond the runway 4R approach end threshold, the airplane's rudder was consistently in the trailing edge right direction (nose right), but the airplane's heading was continuously decreasing (nose left) at 1° to 3° per second. The heading stopped decreasing between 4,000 and 4,600 feet, coinciding with FDR data indicating a brief stowing of the thrust reversers. About 5,200 feet beyond the runway threshold, as full right rudder was being applied, the heading decreased about 1.5° per second until 5,800 feet, when FDR data indicated that the thrust reversers were stowed again. At this point, the yaw rate reversed, and the heading started to increase up to 7° per second. About 6,600 feet beyond the runway threshold, the left reverser was deployed, but the right reverser remained stowed; with the engine EPRs at an idle power level, the airplane continued to yaw nose right about 4° per second. The ground trajectory and FDR data showed that, between 2,800 and 5,000 feet beyond the threshold, both the right and left elevator surfaces were deflected full nose down (15°).

The left engine EPR was greater than 1.3 almost continuously between 3,200 and 5,800 feet beyond the runway 4R approach end threshold while the thrust reverser was

⁹³ The FDR records pressure altitude, that is, altitude data based on an altimeter setting of 29.92 inches of Hg (the standard pressure at sea level).

⁹⁴ Gusty winds involve a fluctuation in wind speed of 10 knots between lulls and peaks. Turbulent winds imply vertical motion and rolling.

⁹⁵ The drift angle is the difference between the airplane's heading and the direction of the velocity vector of the center of gravity.

deployed. The right engine EPR also reached levels above 1.3 several times while the thrust reverser was deployed. The left brake pedal was relaxed briefly about 5,500 feet beyond the runway threshold, coinciding with a stowing of the thrust reversers and a loss of deceleration. The calculated ground trajectory indicated that the flight 1420 airplane departed runway 4R at about 97 knots and impacted the runway 22L approach lighting system support structure at about 83 knots.

1.16.4.2 Ground Deceleration Study

The effects of various deceleration devices on flight 1420's stopping distance was evaluated using The Boeing Company's MD-80 Operational Landing Program. The conditions tested in the program were as follows:

- airplane weight, 127,000 pounds;
- center of gravity position, 16.7 percent of mean aerodynamic chord;
- temperature, 25° C (77° F);
- rolling friction coefficient, 0.02;
- wet runway braking friction coefficient, ranging from 0.21 to 0.28 at flight 1420's speeds from touchdown to the end of the runway;
- touchdown speed, 152 and 162 knots;
- reverse thrust, none and constant symmetric reverse at 1.3 EPR;
- braking, none, flight 1420's braking profile (initial braking at 5 seconds after touchdown and full braking 6 seconds later), and a braking profile in which initial braking occurred 1/4 second after touchdown and full braking 1 1/4 seconds later; and
- spoilers, deployed and not deployed.

Computer runs were made to test airplane deceleration with different combinations of spoiler deployment, reverse thrust, and braking scenarios.

Selected computer runs showing ground speed versus distance from the runway 4R threshold were compared with flight 1420's calculated ground speed profile. All of the selected computer runs were based on an initial ground speed of 162 knots, which was close to the 160-knot touchdown ground speed determined from the ground trajectory calculation, and an initial position on the runway of 2,000 feet from the threshold, which was about the point where flight 1420's tire markings began. Constant, symmetrical reverse thrust at 1.3 EPR was maintained until the ground speed was zero, and all of the braking was based on flight 1420's braking profile.

With no braking, spoilers, or reverse thrust, the airplane would depart the runway with a ground speed of about 142 knots, which is 45 knots faster than the flight 1420 airplane. With no spoilers or brakes but with a constant, symmetrical reverse thrust at 1.3 EPR, the airplane would leave the runway at 117 knots, which is 20 knots faster than the flight 1420 airplane. With no spoilers but with 1.3 EPR reverse thrust and the flight

1420 braking profile, the airplane would have departed the runway at 95 knots. This computer run matched the flight 1420 data best and indicated that the accident airplane experienced a braking coefficient of at least 0.21 to 0.23 at speeds between 160 and 140 knots, respectively.⁹⁶ Figure 16 shows the results of the computer runs compared with the flight 1420 profile.

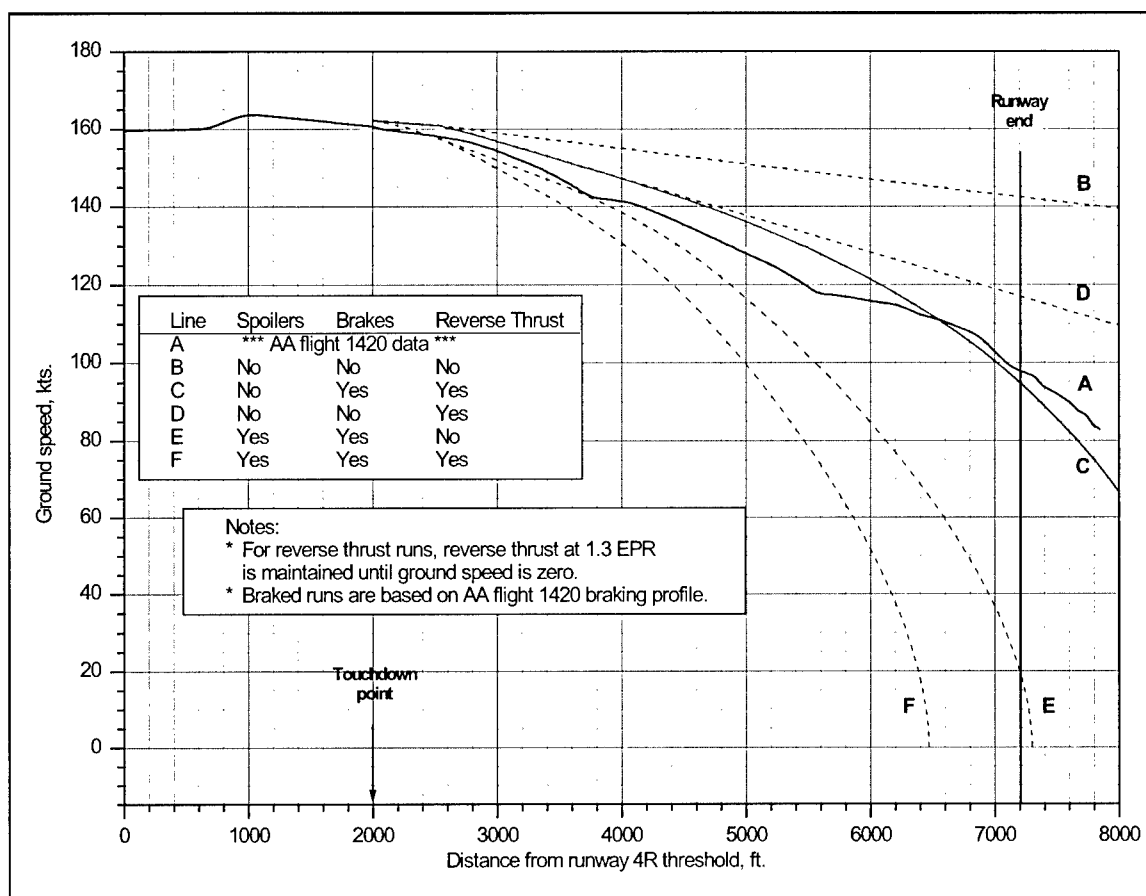

Figure 16. Effects of Spoilers, Brakes, and Reverse Thrust on Stopping Distance

Two additional computer runs demonstrated that proper spoiler deployment is critical to deceleration and stopping distance. Without reverse thrust and with the spoilers deployed and the flight 1420 braking profile, the airplane would depart the runway at 20 knots, which is 75 knots less than the airplane with no spoilers but with reverse thrust and braking. With constant reverse thrust, deployed spoilers, and the flight 1420 braking profile, the airplane could have stopped about 700 feet before the end of the runway.

Computer runs were also performed to determine the effect of the touchdown ground speed on stopping distance. One computer run indicated that an airplane with no spoiler deployment but with reverse thrust and a 10-knot reduction in the touchdown ground speed would have departed the runway at 60 knots and would have impacted the

⁹⁶ Typical braking coefficients for a hydroplaning airplane range from 0.02 to 0.04.

runway 22L approach lighting system support structure at a speed of 20 knots, which is a 94-percent reduction in the kinetic energy compared with the calculated 83-knot impact speed in the flight 1420 profile. Another run that allowed for a loss in braking performance after the airplane departed the hard surface of the runway indicated that the impact speed would have been 45 knots, which is a 72-percent reduction in the kinetic energy compared with the calculated 83-knot impact speed. In addition, without reverse thrust but with spoilers deployed and a 10-knot reduction in the ground speed, an airplane would have been able to stop about 400 feet before the end of the runway.

Finally, computer runs were conducted to determine the effect on stopping distance of a braking profile in which initial braking occurred 1/4 second after touchdown and full braking 1 1/4 seconds later. (Because of a limitation in Boeing's Operational Landing Program, this comparison could only be done using a touchdown ground speed of 152 knots.) The computer runs indicated that, without spoiler deployment but with reverse thrust, the normal braking profile would stop an airplane 200 feet sooner than the flight 1420 braking profile. With spoiler deployment and no reverse thrust, the normal braking profile would stop an airplane 800 feet sooner than the flight 1420 braking profile.

1.16.5 Engineered Materials Arresting System Computer Model

The Safety Board requested that Engineered Arresting Systems Corporation of Lester, Pennsylvania, survey the accident area and provide information on any safety benefit that a soft-ground aircraft arresting system would have provided for flight 1420 if such a system had been installed at the departure end of runway 4R.⁹⁷ At the Board's public hearing on this accident, a consultant for Engineered Arresting Systems discussed the company's Engineered Materials Arresting System (EMAS). The consultant described the EMAS as a passive system that decelerates an airplane when its wheels roll through a soft foamy material.⁹⁸ He added that the system was designed to be compatible with all of the airplanes with which it would come in contact.

The computer program that was used for the analysis assumed the following conditions based on data from the accident sequence:

- runway departure speed, 98 knots;
- gross weight, 128,000 pounds;
- center of gravity, 16.7 percent mean aerodynamic chord;
- yaw angle, 20°;

⁹⁷ On April 14, 1999, the FAA, the Little Rock Municipal Airport Commission, and the airport's tenants met at a joint planning conference to identify airport development needs for the next 5 years. According to the conference report, an arresting system for runway 4R/22L was identified as a recommended project for 2000. In the fall of 2000, an EMAS measuring 304 feet long and 200 feet wide was installed at the departure end of runway 4R.

⁹⁸ The consultant stated that the material has an average strength in compression of 80 psi and that the material would retain its properties over a wide temperature range.

- yaw rate, 0.069 radians per second;
- lateral velocity, 8 knots;
- roll angle, 2° right wing down; and
- distance offset from runway, 7 feet.

The analysis also included an EMAS that was designed to reflect the conditions that existed at the departure end of runway 4R. The total length of this EMAS was 402 feet.

In a December 7, 1999, report to the Safety Board, Engineered Arresting Systems concluded that the benefit of an EMAS in this accident would have been limited by the airplane traveling partly outside the runway edges; thus, the airplane would not have been able to use the full length of the EMAS. The report also concluded that an EMAS would have reduced the speed of the airplane by 15 knots but would not have enabled the airplane to stop within runway 4R's runway safety area. In addition, the report concluded that, in this accident, an EMAS could have led to two landing gear failures because the loads exceeded the ultimate values determined by the airplane manufacturer.⁹⁹

1.17 Organizational and Management Information

American Airways was incorporated in 1930, and its name changed to American Airlines, Inc., in 1934. American is owned by the AMR Corporation and is headquartered in Dallas, Texas. American provides passenger and cargo service throughout North America, the Caribbean, Latin America, Europe, and the Pacific. AMR Corporation also owns and operates American Eagle, a regional airline that provides service at American's hubs and other cities throughout the United States, Canada, the Bahamas, and the Caribbean.¹⁰⁰ In February 1999, American acquired Reno Air, which was fully integrated into American's operations at the end of August 1999. In April 2001, American acquired Trans World Airlines.

⁹⁹ The Safety Board notes that, although the Engineered Arresting Systems report indicated that an EMAS would not have stopped the flight 1420 accident airplane, the system's safety benefit was demonstrated in the May 8, 1999, accident involving American Eagle flight 4925, which overran the approach end of runway 4R at John F. Kennedy International Airport, Jamaica, New York, during landing. The airplane crossed the runway threshold at a speed of about 180 knots and touched down 7,000 feet beyond the end of the runway at a speed of about 157 knots. The flight crew applied reverse thrust and maximum braking, but the airplane departed the 8,400-foot runway at a speed of about 75 knots. Approximately 300 feet of skid marks were observed before the end of the runway. The airplane then traveled over a 6-inch deflector and approximately 248 feet across a 400-foot long EMAS. The landing gear sank approximately 30 inches into the EMAS, and the airplane came to a stop. Of the 30 people aboard the airplane, 1 person was seriously injured, and the rest were not injured. The airplane received substantial damage. See section 1.18.6 for additional details on this accident.

¹⁰⁰ At the public hearing, the AMR Corporation's Vice Chairman stated that, even though American Eagle operates under its own certificate, the airline is considered to be a "sister company" to American Airlines, and both airlines are increasingly sharing human and other resources.

According to the AMR Vice Chairman, American Airlines experienced a period of substantial growth during the 1980s, both in the number of aircraft and the number of employees. American's Web site indicated that, as of March 2000, the airline had 649 transport-category airplanes in its fleet with an average age of 8 years. The fleet consisted of Airbus A300; Boeing 727, 737, 757, 767, and 777; Fokker F.100; and McDonnell Douglas DC-10, MD-11, and MD-80 airplanes.¹⁰¹

At the time of the accident, American Airlines employed 9,661 pilots, 2,812 of whom were qualified on the MD-80 (1,440 captains and 1,372 first officers). The company had 279 MD-80 series airplanes in its fleet and 10 MD-80 bases throughout the United States. The company had a total of 498 check airmen, 108 of whom were MD-80 check airmen.

American Airlines underwent an executive reorganization on January 5, 2000. According to the AMR Corporation's Vice Chairman, changes to the company's organization were proposed before the Little Rock accident but had not been implemented because of a lack of consensus that "any particular change was appropriate or meaningful." The AMR Vice Chairman indicated that the new organizational setup was a "highly integrated but extensive attempt to provide more safety emphasis at the company."

At the time of the accident, the Managing Director of Flight Safety reported to the Vice President of Flight/Chief Pilot, who was responsible for hiring pilots, training them, and managing flight operations. The Vice President of Flight/Chief Pilot reported to the Executive Vice President of Operations,¹⁰² who reported to the Chairman of American Airlines and AMR Corporation.

Under the reorganization, the Executive Vice President of Operations was elevated to the Office of the Chairman as the AMR Corporation Vice Chairman, and he retained the primary responsibility for operations. Eight organizational units report to the Office of the Chairman, including a new unit, Safety, Security, and Environmental.¹⁰³ These three functions existed separately under the former organization but are now placed under a

¹⁰¹ The AMR Vice Chairman indicated that American was planning to retire its older fleets—the 727 and DC-10.

¹⁰² The Executive Vice President of Operations (now the AMR Corporation Vice Chairman) was responsible for eight other organizational units: Maintenance and Engineering, Operations Planning and Performance, Cargo, Reno Air Integration, Corporate Real Estate, Purchasing, Security, and Safety. In public hearing testimony, the AMR Vice Chairman indicated that the areas that received most of his attention as Executive Vice President of Operations were maintenance and flight.

¹⁰³ The seven other organizational units that report to the Office of the Chairman are Human Resources, General Counsel, Operations, Customer Services, Marketing and Planning, Finance, and Government Affairs.

single vice president-level leadership.¹⁰⁴ The Managing Director of Safety reports to the Vice President of Safety, Security, and Environmental and coordinates with the Vice President of Flight/Chief Pilot, who is responsible for the Flight Department.¹⁰⁵

Four main organizational units exist within the Flight Department, one of which is Flight Training and Standards. Ground school and simulator training are separate organizational units within Flight Training and Standards rather than a combined unit within the training organization. The AMR Vice Chairman indicated that the training and standards (that is, checking) functions were separated to provide improved objectivity and standardization.

1.17.1 Aviation Safety Action Program

The American Airlines Safety Action Program (ASAP) was implemented in 1994 after 2 years of development and coordination with the FAA and the Allied Pilots Association.¹⁰⁶ ASAP is a voluntary, confidential pilot reporting program designed to collect and disseminate information on safety issues and incidents to prevent their recurrence. The program receives about 3,600 reports each year.¹⁰⁷ No disciplinary actions are taken against pilots as a result of an ASAP report submission. The Managing Director of Flight Safety administered the program at the time of the accident. At the Safety Board's public hearing, the Vice Chairman of AMR Corporation testified the following:

[ASAP] is a true accident prevention program. It operates on the basis of the following principle, and that is that the best safety information is the information that we don't know, and, so, any way that we can create to bring information that otherwise would not be known to those who can effect change, to bring that information to the surface is very, very valuable, and that's what ASAP's principle concept is all about.

ASAP requires that pilots submit a report of an event within 24 hours of its occurrence (or within 24 hours of the time at which the pilot became aware that an event occurred). ASAP reports are sent to the ASAP Event Review Team, which consists of a representative from American, the FAA's Certificate Management Office for American, and the Allied Pilots Association.¹⁰⁸ The team meets weekly to review submitted reports,

¹⁰⁴ Two new functions were also added to the Safety, Security, and Environmental organizational unit: Operational Audits and Compliance. The AMR Vice Chairman testified that, "in these areas, we intend to substantially pick up...our auditing processes by third parties who are not responsible for...particular operational functions throughout the company."

¹⁰⁵ The Vice President of Flight/Chief Pilot reports to the Managing Director of Operations, who reports to the Managing Director of Safety.

¹⁰⁶ The program is consistent with the guidance in AC 120-66, "Aviation Safety Action Programs."

¹⁰⁷ ASAP reports do not include deliberate or criminal acts or events that are already known within the FAA.

¹⁰⁸ Confidential reports are also sent to the manager of the ASAP program, the appropriate manager within American's Flight Safety Department, and NASA for inclusion in its Aviation Safety Reporting System. In addition, the FAA has immediate access to ASAP reports.

decide which ones represent a significant safety concern or deviation from procedure, and determine who should investigate the events and recommend corrective actions.

According to American's pilot magazine, *Flight Safety*,¹⁰⁹ ASAP reports identify, in order of frequency, altitude deviations; heading deviations; other flight irregularities, communication problems with ATC, or clearance deviations during flight; deviations from regulations or operational procedures, including the MEL; general irregularities or communication problems with ATC on the ground; runway or taxiway incursions; and other categories, including aircraft damage, turbulence encounters, and mechanical problems. The Managing Director of Safety stated that ASAP does not currently collect information about the relationship between an event and the flight crew's flight and duty time.¹¹⁰

Selected information from deidentified ASAP reports is distributed to company pilots via bulletins every 6 weeks. Information from ASAP reports can also be communicated quarterly through the company's pilot magazine. In addition, ASAP reports are entered into an American Airlines database, which provides the company with trend information on particular subjects and areas of focus for training and surveillance.

1.17.2 Flight Crew Training

American's flight crew training academy is located in Dallas/Fort Worth. All first-time pilots at American Airlines attend a basic indoctrination course, where they are taught general information on the way the company operates. According to the MD-80 Fleet Manager at the time of the accident,¹¹¹ basic indoctrination training includes an alertness strategies course, which focuses on fatigue countermeasures more than fatigue recognition.

Pilots then attend initial and/or transition ground school and simulator flight training. According to the American Airlines DC-9 Initial and Transition Training Syllabus (dated December 15, 1998), the typical initial and transition training consists of 10 days of ground school, 10 days of simulator flight training, and 25 hours of initial operating experience (IOE).

Ground school training is presented using self-paced computer-based training with graphics and audio, videotapes, and a performance workbook with printed practice problems. Days 1 through 5 of simulator training are conducted by an American Airlines simulator instructor, and days 6 through 10 are conducted by an American Airlines check airman. For their IOE, new and upgrade pilots fly with a check airman, who references a worksheet that details the airplane maneuvers, procedures, or functions that are required to

¹⁰⁹ Chidester, T. "ASAP Turns Five and a Half." *Flight Safety*. American Airlines, Vol. 1, No. 2, First Quarter (2000): pp. 11-16.

¹¹⁰ Although the reports contain time-of-day information, the Managing Director of Flight Safety stated that the information is used only to correlate reports with ATC records.

¹¹¹ American Airlines' MD-80 Fleet Manager at the time of the accident became the company's Managing Director of Flight Crew Relations in December 1999.

be covered. In addition, all pilots are required to attend recurrent training (a 2-hour line-oriented flight training [LOFT] session) and perform a 2-hour proficiency check ride every year.¹¹² The recurrent training and the proficiency check ride are conducted by company check airmen.

The former MD-80 Fleet Manager indicated that, in all phases of training and IOE, American attempts to put the pilot in a situation in which he or she is required to make the best decision for the particular circumstances. The former fleet manager also indicated that first officers are trained to provide feedback to captains; specifically, first officer trainees are presented with various situations and are critiqued on their actions and the consequences of those actions.

1.17.2.1 Simulator Flight Training

Day 1 of the 10-day initial and transition simulator flight training course includes a briefing on American's checklist philosophy for flying and nonflying pilots. The simulator profile during that day emphasizes how each checklist is accomplished and which items require a response.

Day 6 of the course is dedicated to takeoff and landing exercises. According to the former MD-80 Fleet Manager, the day begins with a 2-hour briefing that covers the key points regarding the airplane's handling characteristics and the windshear escape and recovery maneuvers. The former Fleet Manager indicated that the simulator session starts out with little or no crosswind and a dry runway and that the crosswind component is gradually increased until the MD-80's demonstrated maximum crosswind component is attained. Afterward, the runway surface friction component is reduced. This process is repeated until the pilots have experienced the control difficulties that they need to learn to correct.¹¹³ The former MD-80 Fleet Manager stated that the simulator can replicate rudder blanking (that is, the decrease in rudder effectiveness resulting from an increase in reverse power) and that this feature allows the company to train pilots to reduce the amount of reverse thrust until they have regained directional control.

The training syllabus indicates that windshear profiles, slippery runways, crosswind landings,¹¹⁴ and nighttime landings are discussed during day 6. The syllabus did

¹¹² American's recurrent training syllabus changes on February 1 of each year. According to the former MD-80 Fleet Manager, the recurrent training course beginning on February 1, 2000, was expected to include a briefing on manual spoiler operation and the spoilers' effect on braking and stopping. Each pilot would then have a chance to manually operate the spoilers in the simulator. The recurrent training was also expected to include a review of the stabilized approach concept, wet and slippery runway reversing, and automatic braking.

¹¹³ American's Instructor/Check Airman Guide, MD-80 Supplement, did not contain any guidance for instructing landings with crosswinds or on wet runways. According to American, its instructor guides refer the instructor to the appropriate flight and operating manuals for this information.

¹¹⁴ The former MD-80 Fleet Manager stated that crosswind training is also taught in ground school during a day in which the contents of the performance manual are discussed. The manual contains a chart depicting the headwind, tailwind, and crosswind components in relation to wind speed and the angle between the wind and the runway direction.

not contain any description of the specific scenarios taught during those sessions but did contain a reference to the company's DC-9 Operating Manual.

Day 8 of the training includes the captain's rating ride preparation and the first officer's check ride. The captain's rating ride occurs on Day 9 of the training and is administered entirely in the DC-9 flight simulator. The rating ride consists of about 15 basic profiles, and the training manual indicates that the rating ride is conducted "in real time and in as realistic an ATC environment as possible."

LOFT is conducted on Day 10 of flight training. The LOFT session consists of two legs of a real-time flight in the simulator. According to the syllabus, the first leg is usually routine and flown by the first officer, and the second leg is an abnormal situation that is flown by the captain. The manual stated that the check airman provides realistic flight plans, a weather briefing, and takeoff performance system data for each leg of the flight and that communications with ATC and the company are provided.

1.17.2.2 Observations of Simulator Sessions

In July 1999, two members of the Operations Group observed separate sessions of day 6 (takeoffs and landings) of American's MD-80 simulator training. The sessions were conducted by two different instructors.

One of the simulator sessions (referred to in this report as session A) did not include any "failed spoiler" events during the landing portion of the training. The other simulator session (referred to in this report as session B) included seven failed spoiler events. The students in session B noticed two of the seven events; in both instances, the first officer student manually extended the spoilers. However, American's procedures stated that the captain was to manually extend the spoilers if they did not automatically extend during landing (see section 1.17.4.2). The effects of the spoilers not extending during landing were discussed.¹¹⁵

In session A, the instructor recommended that heavy manual braking be used on contaminated runways and stated that he did not like the autobrakes for landing. In session B, the instructor stated that medium autobrakes should be used when landing on slippery runways. However, American's procedures at the time of the accident stated that aggressive manual brakes or maximum autobrakes should be used with wet runway conditions (see section 1.17.4.3). No discussion occurred in either session regarding what constitutes a slippery runway and what distinguishes it from a wet runway.

During session A, the training focused on using the 1.6 EPR reverse thrust setting (the normal setting used by American for landing on dry runways). There was no discussion or training on company procedures to limit reverse thrust to 1.3 EPR during

¹¹⁵ The two Operations Group members passed along their spoiler training observations to the former MD-80 Fleet Manager who, in turn, met with the simulator instructors to inform them of the observations and implement actions to improve the training. The former fleet manager indicated, during the public hearing, that training on recognizing no-spoiler extensions and performing the appropriate response had been added to day 6.

landing on a slippery runway (see section 1.17.4.4). Rudder blanking was discussed. During session B, the simulator instructor taught that 1.6 EPR was acceptable for landing on a slippery runway unless a crosswind was present,¹¹⁶ and the students applied 1.6 EPR reverse thrust during 10 to 12 landings on slippery runways. The instructor subsequently realized that 1.3 EPR should have been the maximum reverse thrust used and informed the students of this information. Rudder blanking was discussed.

Session A did not include a discussion of company procedures for crosswind limits for reduced visibility operations and contaminated runways but emphasized the importance of avoiding thunderstorms. Session B included a discussion of crosswinds and their effects on takeoffs and landings.

1.17.2.3 Human Factors and Safety Training

In 1990, American Airlines established a manager position dedicated to human factors and safety training.¹¹⁷ This manager is supported by 10 staff facilitators who are company line captains and first officers on detail to the Human Factors and Safety Training program.¹¹⁸ At the time of the accident, five of the facilitators were qualified on the MD-80.

The human factors and safety training program courses emphasize four fundamental principles—situational awareness, communication, teamwork, and technical proficiency—through lectures, slide and videotape presentations, and group discussions. The videotapes present event scenarios that were recreated in a simulator. Many of the recreated events were derived from ASAP reports. The facilitators guide the group discussion to ensure that every element of the event is addressed, including factors that may have prevented the event from occurring.

American provides separate human factors and safety training courses to its pilots, flight attendants, and dispatchers. The courses for pilots include a 3-hour basic indoctrination course, a 4-hour first officer upgrade course, a 1-day captain upgrade course, a 2-hour recurrent course, and a 2-day check airman course. The first officer upgrade course, attended by new first officers, emphasizes their roles and responsibilities in the cockpit, including the need to speak up when an airplane is being handled improperly or placed in jeopardy. The captain upgrade course, attended by new captains, emphasizes strategies for being an efficient manager of events. The recurrent course, attended jointly each year by captains, first officers, and flight engineers, emphasizes areas that parallel those taught during recurrent simulator training.¹¹⁹

¹¹⁶ A member of the Operations Group informed the instructor of the discrepancy between this statement and the operating manual requirement to limit reverse thrust to 1.3 EPR when landing on slippery runways.

¹¹⁷ Before 1996, this program was known as the crew resource management program.

¹¹⁸ While on detail to this program, captains serve half of the time as check airmen for an airplane fleet, and first officers fly as line pilots two times per month and then every third month.

¹¹⁹ The 1999 recurrent training course emphasized decision-making and managing the environment when faced with conflicting demands and information.

1.17.3 Approach Procedures

1.17.3.1 Approach Briefing

American Airlines' Flight Manual, Part I, Section 10, "Approach and Landing," page 12 (dated April 7, 1999), states that the captain will ensure that the first officer and the flight engineer (if applicable) are briefed before every approach.¹²⁰ American's DC-9 Operating Manual, Volume 1, Normals, page 87 (dated April 26, 1999), indicates that, for all instrument approaches, the approach briefing is to include the following:¹²¹

- landing runway and reported visibility or RVR;
- type of approach to be conducted;
- if a nonprecision or Category I ILS approach, who will be the flying pilot;
- approach chart to be used and the applicable minimum visibility or RVR;
- approach facility and frequency;
- final approach course;
- airport elevation;
- outer marker crossing altitude or minimum crossing altitude at final approach fix;
- minimum descent altitude, decision altitude, and decision height, as applicable;
- missed approach procedure;
- minimum safe altitude;
- initial approach altitude; and
- terrain awareness.

1.17.3.2 Before Landing Checklist

The Before Landing checklist is accomplished using a mechanical checklist in the cockpit. According to American's DC-9 Operating Manual, Normals, page 7 (dated December 21, 1998), the mechanical checklist shows 10 items: hydraulic pumps, altimeters, flight instruments and bugs (that is, moveable markers for key airspeed values), seat belt/no smoking signs, tail deice, gear, spoiler lever, autobrakes, flaps and slats, and annunciator lights.¹²² American's Instructor/Check Airman Guide, MD-80 Pilot Supplement, Section 3.01, page 9 (dated July 15, 1996), states that the nonflying pilot was to accomplish the Before Landing checklist and was to "discuss those items requiring

¹²⁰ At the public hearing, the former MD-80 Fleet Manager stated that either pilot could conduct an approach briefing but that the captain was responsible for ensuring that a briefing was completed.

¹²¹ The first officer stated in a postaccident interview that the captain conducted a formal briefing for runway 22L.

¹²² The Before Landing checklist was designed so that the first five items are completed early in the approach and that the last five items are completed late in the approach.

responses and emphasize proper challenges and responses.” American’s DC-9 Operating Manual, Normals, page 71 (dated December 21, 1998), states the following regarding the Before Landing checklist:¹²³

After each item has been accomplished, the pilot-not-flying will call out that item on the checklist, call out the appropriate response and then move the corresponding switch on the Mechanical Checklist. Any item that cannot be verified by the pilot-not-flying as accomplished will require a challenge and response. ALTIMETERS and FLT INSTR & BUGS will be challenged by the pilot-not-flying and responded to by both pilots. When all items have been accomplished, the pilot-not-flying will advise, “Before Landing checklist complete.”

American’s DC-9 Before Landing checklist is found in the DC-9 Operating Manual, Normals, pages 71 through 74 (dated April 26, 1999). Page 72 indicates that the nonflying pilot is responsible for announcing that the spoiler lever has been armed and that the spoilers should not be armed if the AUTO SPOILER DO NOT USE light is illuminated, but no reference could be found to indicate which pilot was responsible for physically arming the spoiler lever. According to postaccident interviews with American Airlines pilots, instructors, and check airmen, pilots were instructed during simulator training that the nonflying pilot was to arm the spoilers. However, company line pilots said that, during actual flights, either pilot could arm the spoilers but that the captain usually did because the spoiler handle was on that side of the center pedestal.

The Before Landing checklist also indicates that the flying pilot is responsible for commanding the landing gear down and that the nonflying pilot is to respond “down three green.” In addition, the Before Landing checklist indicates that the nonflying pilot is to arm the autobrakes as required (see section 1.17.4.3); verbally verify the flap/slat handle position, the flaps position indicator, and SLAT LAND light illumination, and advise the flying pilot of the status of the annunciator panel.

For information on American’s postaccident changes to its Before Landing checklist guidance, see section 1.17.5.1.

¹²³ The FAA reviewed human factors principles of checklist design and incorporated them into its January 1995 publication, *Human Performance Considerations in the Use and Design of Aircraft Checklists*, which is available to airlines and FAA inspectors.

1.17.3.2.1 Manufacturer's Information

Boeing's Flight Crew Operating Manual (FCOM),¹²⁴ Volume II, section 2, contains the following guidance on MD-80 spoiler and autobrake arming under the heading "Before Landing Expanded Procedures":

Lift SPOILER lever, observe lever remains up when released and red arm placard is visible at the base of the lever.

Rotate AUTO BRAKE selector to desired deceleration rate (MIN, MED, or MAX). Move ARM/DISARM switch to ARM.

1.17.3.3 Crew Coordination Procedures

American's DC-9 Operating Manual, Volume 1, Normals, pages 101 and 102 (dated December 21, 1998), states the following regarding crew coordination procedures for a Category I approach:

- Use of autopilot (if operative) is recommended with less than 4000 RVR
- Either pilot callout—"Radio Altimeter Alive"
- Pilot-Flying callouts:
 - "Track—Track"
 - "Outer Marker" and MSL crossing altitude
 - "Auto Go—Auto Land" (if applicable)

The manual also states the following:

Approach

- Pilot-Flying: Fly approach.
- Pilot-Not-Flying: Monitor approach.
- Pilot-Not-Flying: Callouts:
 - "1000" AFL on barometric altimeter—Verbally verify when Flaps/Slats at landing setting
 - "500" AFL on barometric altimeter—Airspeed ± Approach Speed and Descent Rate

¹²⁴ The Chief Pilot for Flight Operations at Boeing's Long Beach Division (who, at the time of the flight 1420 accident, was Boeing's Chief Test Pilot for Flight Operations at Boeing's Long Beach Division) indicated that the company's FCOM is the primary tool used by the company to conduct its training program and establish training programs for operators. Boeing's FCOM provides guidelines for operating procedures, but an operator, along with its principal operations inspector (POI), may change the procedures. The Boeing Chief Pilot stated that the company sends the operators updated information of proposed changes to the manual and that the operator is responsible for coordinating the proposed changes with its POI.

At 100 feet above DA [decision altitude] (on Baro[metric] Altimeter)

Pilot-Flying: When advised that visual references are in sight, confirm requirements to descend below DA are satisfied, callout—“Landing” and complete approach and landing.

Pilot-Not-Flying: Callouts:

- “100 above”
- visual references when in sight

Pilot-Not-Flying: Direct primary attention to monitoring instruments.

At DA (on the Baro[metric] Altimeter)

Pilot-Flying: Execute a missed approach if not completing the landing.

Pilot-Not-Flying: Call out—“Decision Altitude”

Pilot-Not-Flying: Callouts:

- “100” AGL [above ground level] on Radio Altimeter
- “50, 40, 30, 20, 10” AGL on Radio Altimeter (if automated voice callouts are inoperative)

1.17.3.4 Stabilized Approach Concept

American’s DC-9 Operating Manual, Volume 1, Techniques,¹²⁵ page 19 (dated November 15, 1995), indicates the following under the heading “General”:

The stabilized approach concept requires that, before descending below the specified minimum stabilized approach altitude, the airplane should be –

- in the final landing configuration (gear down and final flaps),
- on Approach Speed,
- on the proper flight path and at the proper sink rate,
- and at stabilized thrust.

¹²⁵ Regarding American’s use of the word “techniques,” its DC-9 Operating Manual, Volume 1, Conditionals, page 1 (dated November 15, 1995), states the following: “Techniques are not procedures, but are suggested ways of accomplishing a task. These suggestions are based on experience and recognized practices. Generally, they offer the best method to complete the task in most cases. However, another technique may be just as appropriate, or even better, when considering the particular circumstances.” The former MD-80 Fleet Manager indicated that American was gradually editing out the Techniques section of all of its manuals. The information contained in this section will be integrated into the Normals section so that all of the information for a particular phase of flight will appear in one section.

These conditions should then be maintained throughout the rest of the approach.

The minimum recommended stabilized approach altitudes are:

- VFR [visual flight rules] – 500 feet AFL
- IFR – 1000 feet AFL

In all cases, select landing flaps by 1000 feet AFL.

For information on American's postaccident changes to its stabilized approach procedures, see section 1.17.5.2.

American's DC-9 Operating Manual, Volume 1, Normals, page 89 (dated December 21, 1998), states that "on final, a callout will be made anytime *any crewmember* observes LOC [localizer] displacement greater than 1/3 dot and/or G/S [glideslope] displacement greater than 1/2 dot. The other pilot will acknowledge this deviation."¹²⁶ Page 89 also states that the pilot-not-landing is to make the following deviation callouts: with landing flaps, any time airspeed varies more than ± 5 knots from approach speed and, inside the final approach fix, when rate of descent exceeds 1,000 feet per minute (fpm).

1.17.3.4.1 Federal Aviation Administration Guidance

FAA Order 8400.10, "Air Transportation Operations Inspector's Handbook," volume 4, chapter 2, section 3, paragraph 511, "Stabilized Approach Concept," states that "maintaining a stable speed, descent rate, vertical flightpaths, and configuration is a procedure commonly referred to as the stabilized approach concept" and that "operational experience has shown that the stabilized approach concept is essential for safe operations with turbojet aircraft." The guidance also includes the following information:

A stabilized approach for turbojet aircraft means that the aircraft must be in an approved landing configuration..., must maintain the proper approach speed with the engines spooled up, and must be established on the proper flightpath before descending below the minimum "stabilized approach height" specified for the type of operation being conducted. These conditions must be maintained throughout the rest of the approach for it to be considered a stabilized approach. Operators of turbojet aircraft must establish and use procedures which result in stabilized approaches.

In addition, the guidance indicates that a stabilized approach needs to be established before descending below 500 feet above the airport elevation during VFR conditions or visual approaches and 1,000 feet above the airport or touchdown zone elevation during any straight-in instrument approach in IFR conditions.

¹²⁶ In postaccident interviews, the MD-80 Fleet Manager and several MD-80 check airmen explained that captains used their discretion to determine the maximum acceptable deviation from the glideslope or the localizer.

1.17.3.5 Thunderstorm and Windshear Avoidance

American's Flight Manual, Part I, Section 12, "Weather," page 12 (dated November 30, 1998), states the following regarding thunderstorm avoidance:

Do not enter or depart terminal areas when such areas are blanketed^[127] by thunderstorms except where known thunderstorm-free routes exist and are followed. Airborne radar and all available weather reports will be used to make this determination.

American's DC-9 Operating Manual, Volume 1, Environmental, page 13 (dated August 22, 1997), states the following regarding windshear avoidance:

Avoid areas of known severe windshear.^[128] PIREPS [pilot reports] of windshear in excess of 20 knots or 500 fpm climb or descent below 1000 feet AFL are a good indication of such areas. Consider the time elapsed since the report and the change in reported or observed (radar or visual) weather. Microbursts in particular can create severe windshear conditions, but these conditions develop, change, and dissipate rapidly.

The most dangerous form of windshear is a convective microburst. Some have been documented with wind changes in excess of 200 knots. Because microbursts intensify for several minutes after they first impact the ground, the severity may be up to twice which is initially reported.

Search for clues which may indicate the presence of severe windshear. Severe windshear has been encountered under the following conditions:^[129]

- Thunderstorm and convective clouds
- Rain and snow showers
- Frontal systems
- Low altitude jet streams
- Strong or gusty surface winds

Page 14 of the operating manual states that, when positive indications of severe windshear exist, avoid the areas by diverting around them, initiating a go-around maneuver on approach, or holding on approach until conditions improve. Page 14 also indicates that LLWAS can detect microbursts within 2 1/2 miles of the airport.

¹²⁷The former MD-80 Fleet Manager testified that "blanketed" meant "a significant amount of coverage of the area."

¹²⁸A precise definition of "severe windshear" was not found in American's DC-9 operating or flight manuals.

¹²⁹In public hearing testimony, the former MD-80 Fleet Manager stated that he believed that at least four of the five criteria were probably present during the approach to Little Rock. However, this official also stated that conditions conducive to windshear would necessitate a heightened level of awareness but would not require an approach to be abandoned.

American's Flight Manual, Part I, Section 12, page 13 (dated December 19, 1997), indicates that LLWAS wind reports are "advisory only." The manual also states that "the reported surface winds, as presently obtained from the centerfield instrumentation, are controlling for our Flight Operations." The former MD-80 Fleet Manager stated at the public hearing that he would expect a pilot to evaluate an LLWAS alert by considering the magnitude of the shear and its direction and then decide, with the other pilot, whether to continue or abort the approach. If the crew's decision was to continue the approach, the former fleet manager stated that he would expect the pilot to increase speed and be ready to immediately perform the escape maneuver if an uncommanded change in pitch, roll, or rate of descent occurred because of the windshear.

The former MD-80 Fleet Manager also testified that, in November 1999, American strengthened its guidance for handling windshear warnings. Specifically, the guidance indicates that, if pilots receive a "microburst alert," they are required to execute a go-around or escape maneuver.

1.17.3.6 Continuation of an Approach Below the Decision Height

American's Flight Manual, Part I, Section 10, page 13 (dated November 30, 1998), states the following regarding weather deterioration after the final approach segment has started, in accordance with 14 CFR 121.651(c):¹³⁰

After the aircraft is established on the final approach segment, if the weather is reported to be below published minima, the approach may be continued to the appropriate DH [decision height] or MDA [minimum descent altitude], and landing may be accomplished in accordance with the conditions for the type approach being conducted.

The flight manual further states, "the final approach segment for an ILS approach begins on the glide slope at the glide slope intercept altitude as shown in the [approach chart] profile."

The DC-9 Operating Manual, Volume 1, Normals, page 102, requires the following to continue an approach below the MDA or DH, in accordance with 14 CFR 121.651(c)(1), (2), and (3):

- Airplane must be continuously in a position from which a descent to a landing on the intended runway can be made at a normal rate of descent using normal maneuvers, and where that descent rate will allow touchdown to occur within the touchdown zone of the runway of intended landing.
- Flight visibility must not be less than the visibility prescribed in the standard instrument approach being used.

¹³⁰ Title 14 CFR 121.651(c) states the following: "If a pilot has begun the final approach segment of an instrument approach procedure...and after that receives a later weather report indicating below-minimum conditions, the pilot may continue the approach to the DH or MDA."

- Except for Category II or Category III approaches where any necessary visual reference requirements are specified by authorization of the [FAA] Administrator, at least one of the following visual references for the intended runway is distinctly visible and identifiable to the pilot:
 - Approach light system, except that the pilot may not descend below 100 feet above the touchdown zone elevation using the approach lights as reference unless the red terminating bars or the red side row bars are also distinctly visible and identifiable.
 - Threshold
 - Threshold markings
 - Threshold lights
 - Runway End Identifier Lights (REIL)
 - Visual Approach Slope Indicator (VASI)
 - Touchdown zone or touchdown zone markings
 - Touchdown zone lights
 - Runway or runway markings
 - Runway lights

1.17.3.7 Missed Approach Policy

American's Flight Manual, Part I, section 10, page 21 (dated April 15, 1998), includes the following procedure for performing a missed approach:

When landing cannot be accomplished and, upon reaching the MAP [missed approach point] defined on the approach chart, the pilot must comply with the missed approach procedure or with an alternate missed approach procedure specified by ATC.

The missed approach procedures were revised on August 15, 1999, to add an introductory paragraph that is titled "General" and states the following:

American Airlines has a no-fault go-around policy, recognizing that a successful approach can end in a missed approach. Captains are required to execute/order a missed approach if the aircraft is not stabilized by 1000' AFL (IFR) or 500' AFL (VFR), or if in the pilot's judgement a safe landing cannot be accomplished within the touchdown zone, or the aircraft cannot be stopped within the confines of the runway.¹³¹

¹³¹ The former MD-80 Fleet Manager indicated that American always had a policy of not holding a pilot accountable for performing a go-around and that this revision would ensure that all pilots were aware of this policy.

1.17.4 Landing Procedures

1.17.4.1 Wind Landing Limits

American's Flight Manual, Part 1, section 10, page 20 (dated April 7, 1999), indicates that "pilots shall secure the latest surface wind direction and velocity prior to making a landing at an airport." Section 12 of the flight manual, page 3 (dated April 4, 1997), indicates that "the latest surface wind for use for crosswind and/or headwind and tailwind limitations will be that in the latest weather observation unless a more recent oral report is available from an operating control tower."

Section 10 of the flight manual, page 20, also states that, for approaches conducted with an RVR of 4,000 feet or a visibility of 3/4 mile or greater, the dry runway¹³² maximum demonstrated landing crosswind component for a DC-9 is 30 knots. The manual further states that, for approaches conducted with an RVR of less than 4,000 feet or 3/4-mile visibility, the maximum landing crosswind component is 15 knots and that, for approaches conducted with an RVR of less than 1,800 feet or 1/2-mile visibility, the maximum landing crosswind component for the DC-9 is 10 knots. According to the manual, if the captain believes that "environmental conditions or braking reports indicate that the runway is wet or slippery, the maximum acceptable crosswind should be reduced to 20 knots."

American's DC-9 Operating Manual, Limitations, page 3 (dated April 26, 1999), states that the maximum tailwind limit for takeoffs and landings is 10 knots. The manual also states that the tailwind limit might be further reduced by performance requirements.

1.17.4.1.1 Manufacturer's Information

According to Boeing, the MD-80 is required to safely land with a crosswind of at least 20 knots.¹³³ An aerodynamics engineer from Boeing testified at the public hearing that, during crosswind certification testing, the airplane was found to be capable of handling 30 knots of crosswind. The Procedures section of Boeing's MD-80 Airplane Flight Manual states the following:

The limiting crosswind value has not been determined; however, the maximum demonstrated crosswind component for takeoff and landing is 30 knots reported wind at the fifty foot height. This value was demonstrated on a dry runway.... The accepted industry practice is that the operator use this demonstrated capability and their operational experience to construct their crosswind landing guidance material which is approved by the FAA.

¹³² Section 10 of the flight manual, page 25 (dated April 7, 1999), states that an airport runway is considered to be dry when no snow, slush, ice, or water have been reported and "no more than the following conditions" have been reported: scattered showers in the airport area; intermittent drizzle with an intensity no greater than moderate, intermittent light rain with surface temperatures above freezing; and light snow with surface temperatures below 28° F. Precise definitions for a "wet" or "slippery" runway were not found in American's DC-9 Operating Manual or Flight Manual.

¹³³ The FAA's crosswind certification requirement is that an airplane must be capable of safely landing with a 90° crosswind component of at least 20 percent of the stall speed for dry runway conditions.

Boeing's MD-80 FCOM states, under the heading "Operational Limitations," that the limiting tailwind component is 10 knots.

1.17.4.2 Spoiler Deployment Procedures

American Airlines' DC-9 Operating Manual, Volume 1, Techniques, page 21 (dated November 15, 1995), states that the automatic deployment of the spoilers after touchdown should be monitored and that, if the spoilers do not deploy automatically, the captain should manually deploy them. The manual also indicated, in its Normals section, page 75 (dated December 21, 1998), that "if Spoiler Lever does not move back to full aft (EXT) [extend] position, the Captain, regardless of which pilot is making the landing, will manually deploy spoilers." Page 75 also indicated that the flying pilot and the nonflying pilot are to check that the spoiler lever is full aft after the airplane has touched down. For information on American's postaccident changes to its spoiler deployment procedures, see section 1.17.5.1.

1.17.4.2.1 Manufacturer's Information

Boeing's FCOM, Volume II, section 2, contains the following guidance on MD-80 spoiler deployment under the heading "Landing Roll Expanded Procedures":

For automatic deployment of inboard (ground) spoilers, throttles must be at idle. If throttles are above idle at touchdown, outboard and inboard spoilers may deploy and retract and ABS will disarm.

If SPOILER lever does not move aft or does not remain at EXT [extend] position, PNF call, "No Spoilers," PF move lever aft to full extend position and up to latched position.^[134]

1.17.4.3 Braking Procedures

American's DC-9 Operating Manual, Volume 1, Techniques, page 21 (dated November 15, 1995), states that "the prudent use of manual braking has been shown to reduce brake wear" and that "unless circumstances dictate otherwise, manual braking is generally recommended for landing." Volume 1, Normals, page 74 (dated April 26, 1999), indicates that pilots should use aggressive manual braking or maximum autobrakes on short or slippery runways. Volume 1, Environmental, page 3 (dated November 15, 1995), states under the section "Manual Brake Stopping" that "for short or slippery runways, immediately after nose gear touchdown, use full brake pedal." Volume 1, Environmental,

¹³⁴ The Boeing MD-80 Chief Pilot stated his belief that this procedure had been a part of the company's manual since 1991. The Chief Pilot indicated that most, if not all, of the domestic operators coordinate with the manufacturer, normally by requesting a letter of no technical objection, before making any changes to a manual. The Chief Pilot pointed out that there is no legal requirement for the operator to request a letter of no technical objection. In its April 20, 2000, letter to the Safety Board (see section 1.6.2.2), Boeing indicated that it could not find any record of issuing a letter of no technical objection to American regarding alteration of the manufacturer's recommended spoiler or autobrake procedures.

page 27 (dated April 26, 1999), states that, for landing on a slippery runway, "use aggressive manual braking or maximum auto brakes and auto spoilers."

American's DC-9 Operating Manual, Volume 1, Environmental, page 4 (dated January 31, 1997), states the following regarding the anti-skid system:

When brakes are applied on a slippery runway, several skid cycles will occur before the anti-skid system establishes the right amount of brake pressure for the most effective braking. If the pilot modulates the brake pedals, the anti-skid system is forced to readjust the brake pressure to re-establish optimum braking. During this readjustment time, braking efficiency is lost.

On extremely slippery runways at high speeds, the pilot is confronted with a rather gradual deceleration and may interpret the lack of an abrupt sensation of deceleration as a total anti-skid failure. The natural response might be to pump the brakes or turn off the anti-skid. Either action will degrade braking effectiveness.

For information on American's postaccident changes to its braking procedures, see section 1.17.5.1.

1.17.4.3.1 Manufacturer's Information

Boeing's FCOM, Volume II, section 2, contains the following guidance on MD-80 braking procedures under the heading "Landing Roll Expanded Procedures":

When nose gear is firmly on runway, apply sufficient down elevator after nose gear contact to increase weight on the nosewheel for improved steering effectiveness. (An excessive amount of down elevator will unload the main gear and reduce braking efficiency.)

Volume II, section 3, of the manual contains the following information on operating on wet or slippery runways:

On contaminated surfaces, full braking should be used to realize optimum antiskid operation. Autobrakes if available, should be used in the maximum setting. The normal braking technique on slippery runways is that immediately after nose gear touchdown, apply brake pressure smoothly and symmetrically with maximum pedal pressure and hold until a safe stop is assured.

If a landing is planned on a runway contaminated with snow, slush, standing water, or during heavy rain, the following factors must be considered: available runway length; visibility of runway markers and lights; wind direction and velocity; crosswind effect on directional control; braking action; and the probability of hydroplaning and its effect on stopping distances.

If a skid develops, especially in crosswind conditions, reverse thrust will increase the sideward movement of the airplane, in this case release brake pressure and reduce reverse thrust to reverse idle, and if necessary, forward idle. Apply rudder

as necessary to realign the airplane with the runway and reapply braking and reversing to complete the landing roll.

1.17.4.4 Use of Reverse Thrust

American Airlines' DC-9 Operating Manual, Volume 1, Techniques, page 21, (dated November 15, 1995), indicates the following:

The application of reverse thrust tends to blank out the rudder. The effectiveness of the rudder starts decreasing with the application of reverse thrust and at 90 knots, at 1.6 EPR (in reverse) it is almost completely ineffective.

If the airplane starts drifting across the runway while reversing, immediately return the reverse thrust levers to idle reverse to assist in regaining directional control and to restore rudder effectiveness.

American's DC-9 Operating Manual, Volume 1, Environmental, page 7 (dated April 26, 1999), states the following under the heading "Slippery Runway – Crosswind":

One of the worst situations occurs when there is a crosswind and sufficient water and speed to produce total tire hydroplaning. Reverse thrust tends to disrupt airflow across the rudder and increase the tendency of the airplane to drift downwind, especially if a crab or yaw is present.

As reverse thrust increases above 1.3 EPR, rudder effectiveness decreases until it provides no control at about 1.6 EPR. Do not exceed 1.3 EPR reverse thrust on the *slippery portions of the runway*, except in an emergency.

Page 27 includes the following guidance for landing on a slippery runway:

- Apply reverse thrust as soon as possible after nosewheel touchdown. Do not exceed 1.3 EPR reverse thrust on the slippery portions of the runway, except in an emergency.
- When reversing, be alert for yaw from asymmetric thrust. If directional control is lost, bring engines out of reverse until control is regained.
- Do not come out of reverse at a high RPM. Sudden transition of reversers before engines spool down will cause a forward acceleration.

For information on American's postaccident changes to its guidance on the use of reverse thrust, see section 1.17.5.1.

1.17.4.4.1 Manufacturer's Information

At the Safety Board's public hearing on this accident, the Chief Pilot for Flight Operations at the Boeing Commercial Airplane Group's Long Beach, California, Division presented information on MD-80 rudder effectiveness during reverse thrust operation. The MD-80 Chief Pilot described thrust reversers as "clam shells" that open up and redirect

engine air flow to help slow the airplane. He indicated that, during reverse thrust operation, the overall effectiveness of the rudder to steer the airplane could be reduced because of the disrupted air flow over the rudder and the vertical stabilizer. According to the Chief Pilot, the thrust reversers disrupt the air that would normally be flowing in a streamline across the rudder and vertical stabilizer, creating a field of air that would be turbulent.

The Chief Pilot stated that an MD-80 traveling at 90 to 100 knots with a 1.6 EPR (dry runway) setting would lose directional control from the rudder. He also stated that, because of the reduced rudder effectiveness, Boeing recommended coming out of reverse thrust until the airplane was going in the intended direction and that, once directional control from the rudder is restored, reverse thrust could be reapplied.

Boeing's FCOM, Volume II, section 2, contains the following guidance on MD-80 reverse thrust operations under the heading "Landing Roll Expanded Procedures":

On a dry runway, reverse thrust of no more than 1.6 EPR should be used, except in an emergency.

On wet or contaminated runways, reverse thrust of no more than 1.3 EPR should be used, except in an emergency.

If difficulty in maintaining directional control is experienced during reverse thrust operations, reduce thrust as required and select forward idle, if necessary, to maintain or regain directional control. Do not attempt to maintain directional control by using asymmetric reverse thrust.

1.17.4.4.2 MD-80 All Operators Letter

On February 15, 1996, McDonnell Douglas issued an all operators letter to all MD-80 operators regarding handling characteristics when landing on wet or slippery runways and a change to reverse thrust management techniques. The letter stated that, because of the reverser efflux pattern resulting from the MD-80's canted reverse thrust buckets, "the aerodynamic forces acting on the vertical stabilizer and rudder are disrupted by an increase in reverse thrust above approximately 1.3 EPR, thus reducing the ability of the rudder and vertical stabilizer to provide optimum directional control." The letter further stated that, "as reverse thrust increases above approximately 1.3 EPR, rudder and vertical stabilizer effectiveness continue to decrease until at reverse thrust greater than approximately 1.6 EPR the rudder and vertical stabilizer provide little or no directional control."

The letter emphasized that rudder effectiveness is extremely important when surface friction is low and crosswind or tailwind conditions are present. The letter indicated that, under these conditions, directional control may only be available from the rudder. The letter also indicated that McDonnell Douglas was revising its recommended FCOM procedures to limit reverse thrust to 1.3 EPR when landing on wet or slippery runways. (Section 1.17.4.4.1 shows the revised recommended procedures, which were in

effect at the time of the Little Rock accident. The procedures that were in effect at the time the all operators letter was issued recommended reverse thrust settings up to 1.6 EPR.)

The letter also stated that, on wet or slippery runways, sufficient nose down elevator should be applied after nose gear contact for improved steering effectiveness. The letter cautioned that an “excessive amount” of down elevator should not be applied because it would unload the main gear and reduce braking efficiency.

1.17.5 Postaccident Actions

After the Little Rock accident, American conducted a three-phase operational and safety evaluation from August to November 1999.¹³⁵ The first part of the evaluation was an independent audit that focused on flight training and the organization and operations of the Flight Department; American sought the input of professional pilots outside the organization who had managed airline operations. According to the AMR Vice Chairman, American “wanted the benefit of having outside eyes looking at how we did business.” The second part of the evaluation was a review by the Allied Pilots Association of the same subjects as in the first evaluation.

The third part of the evaluation was conducted by the “System Analysis Team,” which consisted of representatives from American, the Allied Pilots Association, and the FAA. The team performed a 120-day review of six accidents and two incidents that occurred during the previous 5 years at American to determine why those events occurred and what approaches the airline could take to prevent such events from recurring.

The three phases of the evaluation produced 85 recommendations.¹³⁶ American and the Allied Pilots Association prioritized the recommendations according to importance or safety impact and created a timeline in which to accomplish the recommendations.¹³⁷ At the public hearing, the AMR Vice Chairman indicated that the list of recommendations had been reviewed by the FAA’s Certificate Management Office for AMR Corporation and presented to the Flight Standards Group at FAA headquarters. Figure 17 shows a table, presented by the AMR Vice Chairman, that highlights recommendation categories, their expected completion dates, and their safety impact.

¹³⁵ The former MD-80 Fleet Manager cited two more company actions that were also the result of the Little Rock accident. First, American presented an in-depth review of material related to landing with adverse runway conditions to all MD-80 check airmen at their third quarter 1999 standardization meeting. Second, American retained a radar expert to conduct a 1-day seminar for its check airmen on the use of airborne weather radar. These seminars, which were held between October and December 1999, reviewed each airplane’s individual weather radar systems, the types of echoes that the systems might portray, and the conditions that would be associated with those echoes.

¹³⁶ Because the audits were conducted independently, many of the recommendations addressed common issues. The audits made recommendations in the following general issue areas: structure and effectiveness of the Flight Safety Department, flight training and flight standards, and flight operations.

¹³⁷ The FAA’s POI for American Airlines stated that 17 recommendations were deemed “high priority” with the goal for immediate implementation.

Highlights by Category

	Jan-Mar 00	April-June 00	July 00-Jan 02
S A F E T Y V A L U E	<ul style="list-style-type: none"> • Safety Department reorganization • Vice President of Safety • Departmental Safety Directors • Restore relationship with Allied Pilots Association Safety Committee 	<ul style="list-style-type: none"> • Revise thunderstorm avoidance policy • Revise approach and landing policy 	<ul style="list-style-type: none"> • Implement Flight Operations Quality Assurance • Enhance safety audits • Develop safety performance metrics • Upgrade safety tracking system
	<ul style="list-style-type: none"> • Publish <i>Flight Safety</i> magazine • Improve human factors focus on pilot decision-making 	<ul style="list-style-type: none"> • Flight Operations/System Operations Control Department reorganization • Reexamine Advanced Qualification Program and Single Visit Exemption 	<ul style="list-style-type: none"> • Independent Flight Standards program to monitor flight training • Implement Special Procedures Operational Training
	<ul style="list-style-type: none"> • Improve Chief Pilot communication skills 	<ul style="list-style-type: none"> • Develop computer-based training and digital video training for special airports 	<ul style="list-style-type: none"> • Ensure all crewmembers attend the fatigue countermeasures program

Figure 17. Categories of the Postaccident Audit Recommendations According to Expected Completion Date and Safety Value

On July 20, 2001, American Airlines provided the Safety Board with an update on actions to address the issues that had been identified during the three postaccident safety and operational audits. In addition to the actions involving the reorganization of the company that were previously discussed at the beginning of section 1.17 and the changes to the go-around policy previously stated in section 1.17.3.7, American made changes to its checklist philosophy to require challenges by the nonflying pilot and responses by the flying pilot for all mechanical checklist items (section 1.17.5.1 for the changes to the Before Landing checklist items) and expanded its stabilized approach guidance (see section 1.17.5.2).

American's Flight Safety Department undertook actions to increase its ability to identify and track operational trends and enhanced its internal evaluation program. American is also developing a formal risk management program and a Flight Operations Quality Assurance program that will be integrated with ASAP. In addition, Systems Analysis Team projects were completed, including one associated with pilot decision-making during the approach and landing phases of flight and one associated with stabilized approaches.

American has also acted to improve its severe weather operational guidance. For example, the company revised and expanded its thunderstorm avoidance policies, clarified its wind landing limits to include gusts, expanded the quick reference crosswind table, strengthened guidance for landing on slippery runways during crosswinds, provided all pilots with the manufacturer's weather radar booklet, and entered into a contract to retrofit

airborne predictive windshear weather radar on all company airplanes. In addition, American added pilot decision-making guidance during the approach and landing phases of flight to its Airplane Flight Manual Part I and distributed a technical bulletin to MD-80 pilots that addressed rollout deceleration factors and considerations specific to that airplane.

In addition, training and evaluation standards were revised. For example, American provided its check airmen with additional weather radar training, updated its Human Factors and Safety Training to include additional events that involve flight crew decision-making, and modified the frequency and duration of training cycles under the Single Visit Exemption of the Advanced Qualification Program. Also, "Hot Briefing Items" on thunderstorm avoidance, weather radar usage, landing on contaminated runways, spoiler and deceleration device logic, and autobrake usage have been presented by all of American's fleets. Further, American is developing an intranet-based continuing education training program on radar use and is considering the use of Special Procedures Operational Training as a replacement to LOFT.

American also indicated that it established and implemented fatigue and reserve rest policies for its flight crews. In addition, the company published a "Commitment to Safety" statement to all employees and work groups.

1.17.5.1 DC-9 Operating Manual Changes

American made several changes to its DC-9 Operating Manual after the Palm Springs incident, which occurred 8 months after the Little Rock accident. On February 23, 2000, 1 week after the Palm Springs incident, American issued Revision No. 31 to its DC-9 Operating Manual. The revision indicated that the Before Landing checklist would be accomplished as follows:

- The pilot-not-flying will call out each item on the mechanical checklist.
- The pilot-flying will visually verify that the item has been accomplished, and make the appropriate responses aloud.
- The pilot-not-flying will also visually verify each item, and after obtaining a response, will move the corresponding switch on the mechanical checklist.
- Both pilots will respond to the ALTIMETERS and FLT INSTR & BUGS items.

The revision also stated that the "captain will always arm the spoiler for landing."

On June 22, 2000, American issued DC-9 Operating Manual Bulletin DC-9-42, which further revised the procedures for accomplishing the Before Landing checklist. The bulletin indicated that pilots were to "accomplish the Before Landing checklist by challenge and response as follows":

Pilot-Not-Flying

- Call out each item on the mechanical checklist.
- Verify that item has been accomplished.
- Call out response and move corresponding switch on mechanical checklist.

Pilot-Flying

- Verify and respond to the following items:
 - ALTIMETERS
 - FLT INSTR & BUGS
 - GEAR
 - SPOILER LEVER
 - FLAPS & SLATS

In conjunction with the 1000 foot AFL callout, both pilots will visually confirm that all tabs on mechanical checklist are closed-out, and the pilot-not-flying will call out – “*Before Landing checklist complete.*”

According to American’s February 23, 2000, revision to its DC-9 Operating Manual, both pilots are to check for spoiler deployment. The revision indicates that the captain is still to manually deploy the spoilers if the spoiler lever does not move back to the full aft (extend) position. The revision further indicates that, when the spoilers deploy, the nonflying pilot is to call out “deployed”; if the spoilers do not deploy or fail to remain deployed, the nonflying pilot is to call out “no spoilers,” and the captain is to manually deploy the spoilers.

On June 27, 2000, American issued DC-9 Operating Manual Bulletin DC-9-43, which revised the policy on the use of autobrakes for landing. The revision stated the following:

Autobrakes

If operative, must be armed prior to landing when any of the following conditions exist:

- Runway length less than 7000 feet
- RVR less than 4000 or visibility less than 3/4 mile
- Runway contaminated with standing water, snow, slush, or ice
- Braking conditions reported less than good

In addition, the use of autobrakes is recommended when landing with gusty winds or crosswinds.

Autobrake settings should be appropriate to the conditions: MAX must be used when minimum stopping distance is required (MAX autobrake deceleration rate is slightly less than that produced by full manual braking).

After landing, intervene with manual braking as necessary to slow the airplane at the desired rate.

American's February 23, 2000, revision to its DC-9 Operating Manual indicated that the following reverse thrust procedures were effective immediately for all MD-80 landings:

When nosewheel steering is on the ground, the PF will select idle reverse and apply slight forward pressure on the yoke.

With spoilers deployed and directional control assured, reverse thrust may be left at idle or increased to a target of approximately 1.3 EPR.

Reverse thrust of more than 1.3 EPR should not be used unless stopping distance is in doubt.

Do not remain in reverse thrust if directional control cannot be maintained and do not use asymmetrical reverse thrust to regain directional control.

1.17.5.2 Flight Manual Changes

American's Flight Manual, Part I, Section 10, page 3 (dated July 21, 2000), revised the company's stabilized approach criteria to state the following:¹³⁸

Significant speed and configuration changes during an approach can complicate aircraft control, increase the difficulty of evaluating an approach as it progresses, and complicate the decision at the decision point; i.e., DA, DH, MDA. A pilot must assess the probable success of an approach before reaching the decision point. This requires the pilot to determine that requirements for a stabilized approach have been met and maintained.

To limit configuration changes at low altitude, the airplane must be in a landing configuration by 1,000 feet AFL (gear down and landing flaps).

A stabilized approach must be established before descending below the following minimum stabilized approach heights:

- IMC [instrument meteorological conditions] – 1000 feet AFL
- VMC [visual meteorological conditions] – 500 feet AFL

¹³⁸ This information also appears in American's DC-9 Operating Manual in a section titled "Approach—Landing—Go Around" (dated April 27, 2001).

A stabilized approach means that the airplane must be:

- At Approach Speed ($V_{REF} + \text{additives}$)
- On the proper flight path at the proper sink rate
- At stabilized thrust

These requirements must be maintained throughout the rest of the approach for it to be considered a stabilized approach.

If the stabilized approach requirements cannot be satisfied by the minimum stabilized approach heights or maintained throughout the rest of the approach, a go-around is required.

Section 10, pages 1 and 2 (dated July 21, 2000), provide expanded approach and landing decision-making guidance. For example, under the heading "Thunderstorms and Microburst," the guidance explicitly states that "takeoffs and landings are not permitted when thunderstorms are near the airport unless the runway and flight path are clear of thunderstorm hazards." In addition, under the heading "Decision Factors," the guidance provides a list of factors that can influence the decision to begin and continue an approach to either a landing or missed approach, including convective activity, turbulence, visibility/RVR, crosswind, precipitation, and weather trends. Further, the guidance indicates that "pilots should be especially aware of the cumulative factors and trends. For example...thunderstorms approaching an airport suggests holding until passage."

1.17.6 Federal Aviation Administration Oversight

The FAA Certificate Management Office for AMR Corporation is located in Dallas, Texas. The principal operations inspector (POI) for American Airlines stated that the Certificate Management Team was staffed with 17 air safety inspectors and 1 cabin safety inspector at the time of the flight 1420 accident. Of the 17 air safety investigators, 10 were operations inspectors, including the MD-80 Aircrew Program Manager (APM) and the Assistant MD-80 APM, and 7 were geographic inspectors who worked on the American certificate and were assigned to the Air Transportation Oversight System (ATOS) program office.¹³⁹

¹³⁹ The ATOS program was implemented at American Airlines in February 1999. As part of the program, each carrier was to be assigned an FAA analyst to determine trends in reported data. At the time of the accident, the analyst for American had not been assigned. In fact, at the time of the Safety Board's public hearing on this accident, only 1 of the 10 carriers had been assigned an analyst. American's analyst has now been hired and was expected to begin work on April 24, 2001. The ATOS program will be discussed in detail in the Board's final report on the January 31, 2000, Alaska Airlines flight 261 accident.

1.17.6.1 Principal Operations Inspector

The POI for American Airlines authorizes the airline's operations through the issuance of operations specifications. The POI is also responsible for approving manuals and their revisions and reviewing surveillance records of training and line operations.

The POI indicated during public hearing testimony that, when a manufacturer has recommended revisions to its operating manual, he routes the revisions to the appropriate APM, who reviews the information with the carrier. The POI stated that he relies very heavily on the opinion of the appropriate APM in deciding whether to approve a change to the operating manual because the APM has the technical expertise for the specific airplane and works closely with the FAA's Aircraft Evaluation Group, the manufacturer, and the carrier. The POI also indicated that a carrier might choose not to make a manufacturer's suggested change because of the way that carrier has configured the particular airplane.

According to his testimony, the POI indicated that he ensures that pilot training is being performed satisfactorily through the APMs. The POI also stated that he is notified when any training event is not in compliance with company procedures and when line operations do not comply with company procedures.

The POI testified that a hiring freeze had severely impacted his office's ability to conduct surveillance. According to the POI, his emphasis areas at the time of the flight 1420 accident included the surveillance of American's two new airplane fleets (the 737 and the 777) and the company's South American operations. The POI indicated that, at the time of the public hearing, he had 16 air safety inspectors (6 of which were geographic inspectors) but wanted a total of 30 air safety inspectors (10 of which would be geographic inspectors). In addition, the POI indicated that he did not have a say in where the geographic inspectors were physically located. For example, at the time of the public hearing, the POI's staff included a geographic inspector in Las Vegas but not one in New York or San Francisco, where American has a large volume of operations.¹⁴⁰

1.17.6.2 Aircrew Program Manager

The FAA's APM for American's MD-80 program at the time of the accident had worked in this position since 1984. The APM, along with the Assistant APM for American's MD-80 program, were responsible for all operational aspects of American's MD-80 fleet, including the flight training program. The APM and Assistant APM were current and qualified on the MD-80.

In a postaccident interview, the APM stated that workload and personnel constraints did not allow him or the Assistant APM to monitor most of American's proficiency check rides and type rating certifications of pilots. The APM indicated during that interview that, under his supervision, approximately 17 check airmen from American

¹⁴⁰ In August 2000, the POI for American indicated that he was "finally" assigned a geographic inspector who is located in New York. The POI indicated that the inspector would be ready to conduct inspections at the beginning of 2001—after he completes ATOS training and receives carrier-specific briefings.

(appointed by the FAA as aircrew program designees) did most of the airman certification activities.¹⁴¹ He further indicated that the only certification work he performed was examining a new aircrew program designee or rechecking a pilot who had failed two consecutive check rides. The APM stated that he tried to observe the aircrew program designees each year before they were renewed, in accordance with volume 5 of FAA Order 8400.10, "Air Transportation Operations Inspector's Handbook."

The APM indicated that workload constraints prevented him from observing all of American's check airmen on a regular basis. The APM stated that he observed all check airmen at least every 2 years, in accordance with FAA Order 8400.10, volume 3.

The APM explained that he and the Assistant APM were the only ones responsible for observing American's MD-80 training. He further stated that they were "spread thin" and that it was "extremely difficult to cover all of the things that are going on at American Airlines, from an observation standpoint of training." The APM stated that he tried to review the training manuals once a year and that the only simulator training he had time to observe was when a check airman was performing a proficiency check.

The APM testified that he relied heavily on American Airlines to ensure standardization in its simulator training program. According to his testimony, American's senior designated examiners, referred to as coordinators, observe every check airman and every simulator instructor at least once a year. The APM stated that these coordinators were "highly qualified." In addition, the APM indicated that he tried to further efforts to standardize simulator training through discussions with the MD-80 check airmen during American's quarterly check airmen meetings.

The APM stated that the MD-80 was among the airplane models in American's junior fleet and that about 75 percent of American's new upgrade captains and 50 percent of the company's new hire pilots were assigned to the MD-80 fleet. He also indicated that American's MD-80 fleet averages about 28 new captains per month and that the number of check airmen tripled and the number of designated examiners doubled between the second half of 1998 and the end of 1999. The APM stated that, because of the training workload and personnel constraints, geographic inspectors (including those from offices in Chicago, New York, and Nashville) provided some assistance in observing IOE and line checks.

The FAA's PTRS showed that, for American's MD-80 fleet, surveillance of check airmen was performed 27 times in 1998; surveillance of check airmen administering a line check, 25 times; and surveillance of check airmen during IOE, 60 times. From January to June 1, 1999, surveillance of check airmen had been performed 9 times for American's MD-80 fleet; surveillance of check airmen administering a line check, 18 times; and surveillance of check airmen during IOE, 49 times.

¹⁴¹ The APM testified that, 10 to 15 years ago, 5 or 6 inspectors from his program did all of the certification work but that the FAA did not have that "luxury" any longer because of a reduction in personnel.

According to the APM's testimony, he and the Assistant APM conducted en route inspections to observe whether American's procedures were being correctly performed during line operations. The APM indicated that he critiques flight crews immediately if differences are observed. He further indicated that he has never seen a major problem during en route inspections but that flight crewmembers are on "good behavior" when inspectors are present. The FAA's PTRS showed that, for American's MD-80 fleet, en route surveillance was performed 795 times in 1998 and 537 times from January to June 1, 1999.

1.18 Additional Information

1.18.1 Runway Friction Information

The senior research engineer from NASA's Langley Research Center presented information at the public hearing about the three types of friction loss that can occur on a wet runway surface.¹⁴² They are viscous hydroplaning, dynamic hydroplaning, and reverted rubber skidding (or locked tires). His description of each follows:

The contributing factors for viscous hydroplaning are a damp or wet pavement, medium to high speed, poor pavement texture, and worn tire tread. If a runway has good microtexture¹⁴³ and grooving and the aircraft tires have a good tread design, viscous hydroplaning could be alleviated.¹⁴⁴

The contributing factors for dynamic hydroplaning are a flooded pavement, high speed, low tire pressure, and worn tire tread. If a runway has good macrotexture¹⁴⁵ and grooving and the aircraft tires have high pressure and good tread design, dynamic hydroplaning could be alleviated.¹⁴⁶

¹⁴² The NASA Langley engineer presented the following runway wetness classifications: damp—moisture present on the surface to a depth of less than 0.01 inch, wet—standing water on the surface to a depth between 0.01 and 0.1 inch, and flooded—standing water on the surface to a depth that exceeds 0.1 inch. The NASA Langley engineer testified that the left side of runway 4R was flooded but that the right side was not. He also indicated that the crosswind conditions were not severe enough for the flooding from the left side to have exceeded the runway's centerline.

¹⁴³ Microtexture is a small sandpaper-type of texture that can only be felt.

¹⁴⁴ According to the article, "Landing on Slippery Runways," in Boeing's October to December 1992 *Airliner* magazine, "viscous hydroplaning occurs on all wet runways and is a technical term used to describe the normal slipperiness or lubricating action of the water." The article also stated that viscous hydroplaning reduces friction but not to the level that would prevent an airplane's wheel from spinning up shortly after touchdown.

¹⁴⁵ Macrotexture is the large roughness in the surface that is visible to the eye.

¹⁴⁶ According to the article, "Landing on Slippery Runways," in Boeing's October to December 1992 *Airliner* magazine, dynamic hydroplaning "lifts the tire completely off the runway and causes such a substantial loss of tire friction that wheel spin up may not occur."

The contributing factors for reverted rubber skidding¹⁴⁷ are a wet or flooded pavement, high speed, poor pavement texture, and a deficient brake system. To alleviate reverted rubber skidding, a good pavement structure and grooving and improved antiskid control devices are necessary.

The NASA Langley engineer indicated that a pavement's capability to alleviate slipperiness improves as its microtexture and macrotexture increase. The potential to alleviate slipperiness on smooth pavement surface that is damp or flooded is poor, whereas the potential to alleviate slipperiness on a porous pavement surface that is damp or flooded is excellent. For a transverse grooved runway, such as runway 4R at Little Rock, the potential to alleviate slipperiness during damp conditions is excellent, and the potential to alleviate slipperiness during flooded conditions is good to excellent. The engineer stated that runway 4R's microtexture was above average, macrotexture was excellent, and grooving was satisfactory. In addition, he stated that the runway's ability to prevent hydroplaning and other braking problems was excellent.¹⁴⁸

The engineer stated that dynamic hydroplaning was not a factor in the accident because of the scrub marks on the runway.¹⁴⁹ He further stated that the water depth that would have produced a dynamic hydroplaning effect on runway 4R was approximately 0.28 inches and that, at flight 1420's touchdown point, there would have been less than 0.10 inch of water in that area of the runway located 15 feet from the centerline because of the crosswinds that were moving from left to right.¹⁵⁰ In addition, the engineer stated that he found no evidence of reverted rubber skidding because the runway had good pavement texture and grooving and there was no tread reversion on the four main landing gear tires and no reverted rubber on the runway surface.

The NASA research engineer also provided testimony about antiskid operations. The engineer indicated that normal antiskid operation would be expected with high wheel spin-up accelerations on a high-to-medium runway traction surface and early spoiler deployment at touchdown. He also stated that abnormal antiskid operation would be expected with low- to no-wheel spin-up accelerations on a low- to no-traction runway surface and delayed spoiler deployment at touchdown. According to the NASA engineer, a dilemma with antiskid control systems during crosswind operations is that, to preserve

¹⁴⁷ The terms "reverted rubber skidding" and "reverted rubber hydroplaning" can be used interchangeably.

¹⁴⁸ The Boeing aerodynamics engineer stated during his testimony that runway 4R is "very good" because it has been grooved and has good surface texture.

¹⁴⁹ The NASA Langley engineer indicated that the scrub marks (white-appearing tracks on the pavement that were lighter in color than the adjacent areas, as described in section 1.10.3.1) resulted from the high pressure between the tire print and the wet pavement. He indicated that the marks were caused by the braking action between the tire and the pavement and the steering forces being developed between the tire and the pavement. The NASA Langley engineer stated that the scrub marks led up to tire marks going through the grass and to the accident site. He also stated that no black rubber tire marks were evident on the runway because the pavement surface was wet.

¹⁵⁰ The NASA Langley engineer explained that, under the accident conditions and with the high vertical sink rate at which the airplane touched down, he had "no problem or no question about the wheels spinning up on touchdown."

braking, the antiskid must operate at increasing slip ratios as the airplane yaws but that, to preserve cornering, the antiskid must operate at low slip ratios.¹⁵¹ The engineer stated his belief that flight 1420 could not develop any cornering friction with the wet runway conditions because of the yaw angles the airplane experienced during the accident sequence.

1.18.2 Study on Thunderstorm Penetration in the Terminal Area

Research staff at the Massachusetts Institute of Technology's Lincoln Laboratory conducted a study, sponsored by NASA, of the variables that are correlated with arriving pilots' convective weather penetrations or deviations in the Dallas/Fort Worth terminal airspace.¹⁵² (This airspace encompasses Dallas/Fort Worth International Airport and Dallas/Love Field.) The study analyzed 63 hours of convective weather and flight data for arriving aircraft. The data were collected over nine stormy days between late April and early July 1997. During that time, 1,279 aircraft encountered storm cells 1,952 times; about one-third of the encounters (642) resulted in deviations, and about two-thirds (1,310) resulted in penetrations. The study did not include information from the flight crews regarding the reasons for the actions documented by the flight data.

The data included very few encounters with NWS level 1 (very light) precipitation because of the threshold values used to identify penetrations and deviations. The data indicated that the number of penetrations for level 2 (light to moderate) precipitation was about six times greater than the number of deviations. Further, the data indicated that pilots were more likely to penetrate than deviate around level 3 (strong) thunderstorms, but pilots were more likely to deviate around rather than penetrate level 4 (very strong) and 5 (intense) thunderstorms. Finally, the data showed very few encounters with level 6 (extreme) thunderstorms, but all of the pilots encountering such thunderstorms deviated around them.

In addition, the data indicated that most of the encounters within 20 to 30 kilometers (10 to 16 nm) of the destination airport resulted in penetrations. For example, there were 918 encounters with level 3, 4, and 5 thunderstorms during the data collection period. Of the 297 such encounters within 25 kilometers of the destination airport, 266 (90 percent) resulted in penetrations. However, of the 611 such encounters farther than 25 kilometers from the destination airport, 157 (26 percent) resulted in penetrations. The study also found that, farther from the airport, pilots nearly always deviated around intense storms and penetrated weaker storms and that, closer to the airport, pilots mostly penetrated the storms regardless of their intensity.

Several flight-related variables were tested to determine whether they were correlated to a pilot's decision to penetrate thunderstorms. The tests determined that pilots

¹⁵¹ Slip ratios measure the amount of rolling and skidding in tire motion. For a rolling tire, the ratio is zero; for a skidding tire (or locked wheel), the ratio is one.

¹⁵² Rhoda, D.A. and Pawlak, M.L. 1999. *An Assessment of Thunderstorm Penetrations and Deviations by Commercial Aircraft in the Terminal Area*. Massachusetts Institute of Technology, Lincoln Laboratory, Project Report NASA/A-2.

were more likely to penetrate convective weather when they were following another aircraft, behind schedule by more than 15 minutes, or flying after dark. According to public hearing testimony by the primary author of this study, there were no discernible differences among air carriers regarding the propensity to penetrate or deviate around thunderstorms or among jet versus turboprop airplanes.

1.18.3 Studies on Flight Crew Decision-Making

1.18.3.1 Safety Board Study of Flight Crew Involvement in Major Accidents

The Safety Board issued a 1994 safety study that examined the operating environments and errors made by flight crewmembers in 37 major accidents between 1978 and 1990.¹⁵³ The Board identified 302 flight crew errors in the 37 accidents, 232 of which were considered primary errors and 70 of which were considered secondary errors.

The 232 primary errors were grouped according to type of error. The primary error categories and the number of errors in each category were as follows: procedural (for example, not conducting or completing required checklists or not following prescribed checklist procedures), 73 errors; tactical decision (for example, improper decision-making, failing to change a course of action in response to a signal to do so, and failing to heed warnings or alerts that suggest a change in course of actions), 51 errors; aircraft handling, 46 errors; situational awareness (for example, controlling the airplane at an incorrect target altitude), 19 errors; communication, 13 errors; systems operation, 13 errors; resource management, 11 errors; and navigational, 6 errors. Secondary errors resulted from the failure of a crewmember to monitor or challenge a primary error made by another crewmember.

The study also examined the effect of the length of time since awakening (TSA) on the errors made by flight crewmembers. The performances of flight crews in which the captain and the first officer had been awake an average of 13.8 and 13.4 hours, respectively (referred to as high TSA crews), were compared with the performances of flight crews in which the captain and the first officer had been awake an average of 5.3 and 5.2 hours, respectively (referred to as low TSA crews).¹⁵⁴

The Safety Board found that both the number and type of errors made by the flight crews varied significantly according to the TSA length. Specifically, high TSA crews made an average of 40 percent more errors than low TSA crews. Also, high TSA crews made significantly more procedural and tactical decision errors than low TSA crews. According to the study report, these results suggested that the degraded performance by high TSA crews tended to involve ineffective decision-making and procedural slips rather than a deterioration of aircraft handling skill.

¹⁵³ National Transportation Safety Board. 1994. *A Review of Flightcrew-Involved Major Accidents of U.S. Air Carriers, 1978 Through 1990*. Safety Study NTSB/SS-94/01. Washington, DC.

¹⁵⁴ The safety study's findings related to fatigue are based on only 12 of the 37 accidents examined in the study. There were six high TSA crews and six low TSA crews.

1.18.3.2 National Aeronautics and Space Administration Study on Flight Crew Decision Errors

Researchers at NASA's Ames Research Center in Moffett Field, California, conducted a study that examined the Safety Board's findings in its 1994 safety study.¹⁵⁵ The purpose of the NASA study was to analyze the accident data on the most common flight crew decision errors to determine any themes or patterns within which the errors occurred.

The NASA researchers found that the most common decision errors occurred when the flight crew decided to "continue with the original plan of action in the face of cues that suggested changing the course of action." The study stated that cues that signal a problem are not always clear and that a decision-maker's situation assessment may not keep pace with conditions that deteriorate gradually. The study also stated that individuals have a natural tendency to maintain their originally selected course of action until there is clear and overwhelming evidence that the course of action should be changed. Further, the study stated the following:

[A] recurring problem is that pilots are not likely to question their interpretation of a situation even if it is in error. Ambiguous cues may permit multiple interpretations. If this ambiguity is not recognized, the crew may be confident that they have correctly interpreted the problem. Even if the ambiguity is recognized, a substantial weight of evidence may be needed to change the plan being executed.

In addition, the study noted that pilots under stress might not evaluate the consequences of various options.

1.18.4 Technologies to Detect and Locate Downed Airplanes

Several technologies could help ATC facilities and ARFF units in detecting, locating, and expediting emergency response efforts after aircraft accidents. These technologies include emergency locator transmitters (ELT) and the DEVS. An ELT is a device aboard an airplane that is intended to transmit a signal after an accident to aid rescue personnel in locating the airplane. Airplanes operating under 14 CFR Part 121 are not required to be equipped with an ELT, but it is a recommended practice, under Annex 6 to the Convention on International Civil Aviation, for all airplanes to carry an automatically activated ELT. According to AC 150/5210-19, "Driver's Enhanced Vision System (DEVS)," dated December 23, 1996, the purpose of the DEVS program is to reduce ARFF response times in poor visibility conditions. The system is "aimed at the difficult aspects of poor visibility response: locating the accident, navigating to the accident site, and avoiding obstacles and locating people on the way to the accident site." DEVS consists of three components: a forward-looking infrared device, a global positioning system, and a tracking system.

¹⁵⁵Orasanu, J.; Martin, L.; and Davison, J. *Errors in Aviation Decision Making: Bad Decisions or Bad Luck?* NASA Ames Research Center, Moffett Field, California. Presented to the Fourth Conference on Naturalistic Decision Making, Warrenton, Virginia, May 29-31, 1998.

The FAA's Manager of the Airport Safety and Certification Branch, Office of Airport Safety and Standards, stated that the most important part of DEVS is the forward-looking infrared device because it allows a vehicle's driver to see in almost zero or zero visibility. The range that the system can look ahead depends mostly on the weather conditions. According to the Branch Manager, the device is looking for heat sources, so an airplane on fire in the rain may be harder for the device to find because the rain would cool the plume of smoke from the fire. He added that the device would be effective in snow but that the device's range would be less. The Branch Manager indicated that the FAA requires a forward-looking infrared device to be installed on all of its new fire trucks that carry 1,500 or more gallons. There is no requirement, however, for ARFF personnel aboard these trucks to use this device.

1.18.5 Previous Weather-Related Accidents

USAir Flight 1016, Charlotte, North Carolina, July 2, 1994

On July 2, 1994, USAir flight 1016, a Douglas DC-9-31, N954VJ, collided with trees and a private residence after executing a missed approach to runway 18R at Charlotte/Douglas International Airport, Charlotte, North Carolina.¹⁵⁶ At the time, adverse weather conditions existed over the airport and along the flightpath. Of the 57 people aboard the airplane, 37 passengers were killed; 2 flight attendants and 14 passengers received serious injuries; and the 2 flight crewmembers, 1 flight attendant, and 1 passenger received minor injuries. The airplane was destroyed by impact forces and fire.

The Safety Board determined that the probable causes of this accident were (1) the flight crew's decision to continue an approach into severe convective activity that was conducive to a microburst; (2) the flight crew's failure to recognize a windshear situation in a timely manner; (3) the flight crew's failure to establish and maintain the proper airplane attitude and thrust setting necessary to escape the windshear, and (4) the lack of real-time adverse weather and windshear hazard information dissemination from ATC, all of which led to an encounter with and failure to escape from a microburst-induced windshear that was produced by a rapidly developing thunderstorm located at the approach end of runway 18R.

Contributing to this accident were (1) the lack of ATC procedures that would have required the controller to display and issue ASR-9 weather information to the pilots of flight 1016; (2) the Charlotte tower supervisor's failure to properly advise and ensure that all controllers were aware of and reporting the reduction in visibility and the RVR value information; (3) the inadequate remedial actions by USAir to ensure adherence to standard operating procedures; and (4) the inadequate software logic in the airplane's windshear warning system that did not provide an alert upon entry to the windshear.

¹⁵⁶ National Transportation Safety Board. 1995. *Flight Into Terrain During Missed Approach, USAir Flight 1016, DC-9-31, N954VJ, Charlotte/Douglas International Airport, Charlotte, North Carolina, July 2, 1994*. Aircraft Accident Report NTSB/AAR-95/03. Washington, DC. Section 1.18.7.2 discusses the ARFF emergency response to this accident.

Delta Air Lines Flight 191, Dallas, Texas, August 2, 1985

On August 2, 1985, Delta Air Lines flight 191, a Lockheed L-1011-385-1, N726DA, crashed while approaching to land on runway 17L at Dallas/Fort Worth International Airport.¹⁵⁷ The airplane entered a microburst, which the pilot was unable to traverse successfully. The airplane struck the ground about 6,300 feet short of the runway, hit a car on the highway north of the runway, struck two water tanks at the airport, and broke apart. The 3 flight crewmembers, 5 flight attendants, and 126 passengers were killed; 1 flight attendant and 14 passengers received serious injuries; 2 flight attendants and 10 passengers received minor injuries; and 2 passengers were not injured. In addition, the driver of the car was killed, and 1 rescuer received minor injuries. The airplane was destroyed by impact forces and a postcrash fire.

The Safety Board determined that the probable causes of this accident were the flight crew's decision to initiate and continue the approach into a cumulonimbus cloud, which the crewmembers observed to contain visible lightning; the lack of specific guidelines, procedures, and training for avoiding and escaping from low altitude windshear; and the lack of definitive, real-time windshear hazard information. This resulted in the airplane's encounter at low altitude with a microburst-induced, severe windshear from a rapidly developing thunderstorm located on the final approach course.

1.18.5.1 Previous Weather-Related Safety Recommendations

Since 1974, the Safety Board has issued at least 90 weather-related safety recommendations to the FAA, NWS, National Oceanic and Atmospheric Administration, and others. Three of these recommendations have relevance to the current investigation and are detailed below.

A-95-48 and -52

On April 4, 1995, as part of its final report on the USAir flight 1016 accident, the Safety Board issued Safety Recommendations A-95-48 and -52 to the FAA and NWS, respectively. These recommendations asked each agency to cooperate with the other to

Reevaluate the Central Weather Service Unit program and develop procedures to enable meteorologists to disseminate information about rapidly developing hazardous weather conditions, such as thunderstorms and low altitude windshear, to FAA TRACONs and tower facilities immediately upon detection.

On August 14, 1995, the FAA stated that it had reevaluated its existing procedures to disseminate information about rapidly developing hazardous weather conditions to ATC facilities and believed that the procedures were appropriate. On July 26, 1996, the Safety Board stated that additional procedures must be developed to efficiently use and disseminate hazardous weather information that is available from current and planned

¹⁵⁷ National Transportation Safety Board. 1986. *Delta Air Lines, Inc., Lockheed L-1011-385-1, N726DA, Dallas/Fort Worth International Airport, Texas, August 2, 1985*. Aircraft Accident Report NTSB/AAR-86/05. Washington, DC.

meteorological systems for the center weather service units (CWSU),¹⁵⁸ such as WSR-88D. The Board also indicated that the FAA, along with the NWS, must make a timely, detailed, and comprehensive effort to reevaluate the CWSU program.

On January 6, 1997, the FAA stated that it had been working with the NWS regarding air traffic aviation weather needs associated with the performance of the CWSUs and that it was developing a program to explore the concept of using enhanced weather-trained FAA ATC personnel to perform all CWSU duties. On June 9, 1997, the Safety Board acknowledged the FAA's efforts to date but expressed concerns about its initiative to replace NWS meteorologists at the CWSUs with enhanced weather-trained FAA ATC personnel. On February 28, 1998, the FAA stated that NWS meteorologists would continue to staff the CWSUs. The FAA also stated that it would work with the NWS to standardize CWSU operations and rewrite the national CWSU order based on air traffic requirements. On May 29, 1998, the Board recognized these efforts.

On June 5, 2000, the FAA stated that it and the NWS held a meeting in February 2000 with most of the CWSU meteorologists-in-charge and representatives from both agencies to review current CWSU products and procedures. The FAA stated that the participants agreed on the need to review and update all documentation on CWSU duties and standardize procedures and products. The FAA also stated that the participants determined that equipment should be installed to enable the FAA to relay all weather information, including hazardous weather conditions, to controllers without the need for manual intervention. As a result, the FAA indicated that it was installing an ASOS Controller Equipment-Information Display System (designed to consolidate all weather and aeronautical information into one controller display) in eight TRACON or associated facilities. The FAA anticipated that all eight systems would be installed by September 2001 if funding were available.

On July 14, 2000, the Safety Board indicated that, although the FAA was taking the actions specified in this recommendation, its work was not scheduled to be completed until 6 1/2 years after the recommendation was issued. On August 21, 2001, the FAA indicated that two of the eight ASOS Controller Equipment-Information Display Systems were operational and that the installation of the remaining systems would be completed by the fall of 2001, as long as funding was available for this project. The FAA also indicated that it and the NWS would revise, in early 2002, FAA Order 7210.38A, Center Weather Service Unit, to standardize CWSU operations nationwide. On October 22, 2001, the Board reemphasized its concern about the length of time that had passed since the recommendation was issued but recognized that the FAA appeared to be in the final stages of completing its planned actions. Pending completion of the FAA's planned actions, Safety Recommendation A-95-48 was classified "Open—Acceptable Response."

On November 17, 1997, the NWS indicated that it had several programs underway that were relevant to the intent of Safety Recommendation A-95-52, including programs at NASA and the FAA. On April 15, 1998, the Safety Board stated that it wanted to review the NWS' actions to identify future goals and responsibilities of the CWSUs, identify any

¹⁵⁸ There are 21 CWSUs throughout the United States.

deficiencies in the CWSU program, and institute any necessary improvements. On August 28, 2000, the NWS indicated that the Integrated Terminal Weather System, which would produce fully automated and integrated terminal weather information, had been developed by the FAA and would be fully implemented in 2003. On January 5, 2001, the Board expressed its concern that the NWS appeared to have made little progress in addressing this recommendation and requested that the NWS provide, within 3 months, a schedule of all activities taken in response to this recommendation. On April 5, 2001, the NWS explained that it was beyond the scope of present CWSU operations for weather forecasters to provide continuous weather information services to support terminal operations. The NWS further stated that any increase in the scope of responsibilities for CWSU forecasters would require direction from the FAA, which, according to the NWS, has “reserved the right to make the final decision regarding any changes to the CWSU concept of operations.”

On August 7, 2001, the Safety Board acknowledged that the FAA funds and makes final decisions regarding the CWSU program, but the Board did not believe that the concept of operations regarding center weather support was driven solely by the FAA. The Board indicated that the NWS and FAA should discuss the issues in Safety Recommendation A-95-48 and -52 as part of routine discussions regarding CWSU operations and make plans to address the issues. The Board further noted that, in the 6 years since this recommendation was issued, the NWS has provided few updates on the status of its actions, including the schedule of all recommendation-related activities requested in the Board’s January 2000 letter. Pending receipt of this information and completion of the recommended action, Safety Recommendation A-95-52 was classified “Open—Unacceptable Response.”

A-90-84

On June 18, 1990, the Safety Board issued a safety recommendation letter to the FAA about its windshear program. The letter indicated that the program had generally been well managed and productive and that elements of the program had been well coordinated within the Government and industry. However, the Board determined that additional actions were required by the FAA to ensure maximum protection against low-altitude windshear. As a result, the Board issued Safety Recommendation A-90-84, which asked the FAA to

Develop the modular windshear detection enhancement to the Airport Surveillance Radar (ASR-9) and implement the enhanced ASR-9 at air carrier airports not scheduled for a Terminal Doppler Weather Radar (TDWR) system or as an interim measure at airports scheduled for late TDWR installations.

On February 21, 1995, the FAA stated that it was proceeding with the development of an ASR Weather Systems Processor (WSP). The FAA explained that the WSP is a “cost-effective, add-on, passive radar receiver and weather processor on a host ASR” and that the WSP adds “full TDWR-like performance to existing ASR-9 search radars” by providing windshear and microburst detection, storm cell motion, and prediction of gust fronts for use by air traffic controllers and control tower operators. The FAA further

explained that the WSP would consolidate other weather data from the LLWAS or ASOS into a single display. The FAA indicated that WSP component testing would conclude at the end of 1995 and that the system would be integrated by September 2002 at 33 airports that have medium air traffic density, are subject to windshear, and are not qualified to receive TDWR. On June 20, 1995, the Safety Board indicated that it was pleased with the FAA's plan to develop the WSP but urged the FAA to expedite its efforts to provide windshear protection at airports that are not served by TDWR.

The FAA's letters to the Safety Board between August 1996 and December 1999 detailed the FAA's progress in developing and procuring the WSP systems. The Board's letters to the FAA between December 1996 and March 2000 acknowledged the FAA's efforts to date and restated the Board's concern about the hazard of low-altitude windshear at airports before the WSP systems are delivered.

On July 24, 2000, the FAA stated that it was continuing its efforts to complete the development of the production version of the WSP. The FAA indicated that two WSP prototypes were operating continuously at Albuquerque, New Mexico, and Austin, Texas. The FAA also stated that three limited-production WSP systems were installed at the FAA's Academy, the FAA's William J. Hughes Technical Center, and Albuquerque in January, May, and June 2000, respectively; a fourth limited-production system was in the process of being installed at Austin; a fifth limited-production system would remain with the contractor to serve as a depot repair system; and a sixth limited-production system was scheduled to be delivered to Norfolk, Virginia, in September 2000. In addition, the FAA stated that operational tests and evaluations were to be completed in December 2000 and that full production system deliveries would occur between March 2001 and July 2002 at a rate of two systems per month. On September 14, 2000, the Safety Board expressed its concern about the WSP project's slow pace and pointed out that the project's anticipated completion date of mid-2002 would be 12 years after this recommendation was first issued.

On March 16, 2001, the FAA indicated that, between July and December 2000, it completed initial operational testing and evaluation of the WSP and that all six limited-production systems were continuously operating. The FAA also indicated that, in November 2000, it procured an additional system to be installed in at the FAA's program support facility in Oklahoma City, Oklahoma. In addition, the FAA stated that it had conducted the first operators' training course in November 2000 and the first maintenance training course in December 2000. Further, the FAA stated that follow-on operational testing and evaluation was scheduled to be completed in April 2001 and that initial full-production deliveries would begin then. On May 16, 2001, the Safety Board stated that it would appreciate receiving updates on the delivery schedule.

On July 2, 2001, the FAA stated that, in April 2001, it held a dedication ceremony to commemorate the installation of the first three key site operational WSP systems in Austin, Albuquerque, and Norfolk; the delivery of the first of 32 full-production units to the FAA's program support facility in Oklahoma City; and the initiation of WSP production. The FAA indicated that it had updated WSP software to improve system maintainability and that WSP deliveries would begin by August 2001. On August 27,

2001, the Safety Board noted its concern about the amount of time that has passed since this recommendation was first issued but acknowledged that the FAA was working to have the WSP fully deployed soon. Pending full deployment and operation of all WSP systems by July 2002, Safety Recommendation A-90-84 was classified “Open—Acceptable Response.”

1.18.6 Previous Fatigue-Related Accidents

American Eagle Flight 4925, Jamaica, New York, May 8, 1999

On May 8, 1999, American Eagle flight 4925, a Saab 340B, N232AE, overran the end of runway 4R during landing at John F. Kennedy International Airport, Jamaica, New York.¹⁵⁹ The captain flew the approach with excessive altitude, airspeed, and rate of descent and remained above the glideslope, and the first officer failed to make required callouts, including a missed approach callout. As previously discussed in section 1.16.5, an EMAS installed at the end of the runway stopped the airplane. Of the 30 persons on board, 1 was seriously injured, and 29 were not injured. The airplane received substantial damage.

During postaccident interviews, both pilots stated that they were fatigued. They had been working a continuous-duty overnight schedule (that is, a trip sequence that is flown during the late night hours and the early morning hours of the next day in which the break between flights is not sufficient to qualify as a duty rest period, even if the flight crew is provided with a hotel room for rest). On May 7, 1999, the flight crewmembers awoke during the morning hours, did not sleep during the day, and reported for duty about 2200 for a flight scheduled about 2246. The flight was delayed but arrived at the destination airport—Baltimore-Washington International Airport—about 0025 on May 8. The pilots went to sleep about 0130 and awoke about 0445 for the accident flight, which was scheduled to depart about 0610.

The Safety Board determined that the probable cause of this accident was the captain’s failure to perform a missed approach, as required by company procedures. Contributing to the cause of this accident were the captain’s improper in-flight decisions and failure to comply with FAA regulations and company procedures, inadequate crew coordination, and fatigue.

Korean Air Flight 801, Nimitz Hill, Guam, August 6, 1997

On August 6, 1997, Korean Air flight 801, a Boeing 747-300, Korean registration HL7468, crashed at Nimitz Hill, Guam.¹⁶⁰ The airplane had been cleared to land on runway 6L at Guam International Airport, Agana, Guam, and crashed into high terrain

¹⁵⁹ The description for this accident, NYC99FA110, can be found on the Safety Board’s Web site at <<http://www.nts.gov>>.

¹⁶⁰ National Transportation Safety Board. 2000. *Controlled Flight Into Terrain. Korean Air Flight 801, Boeing 747-300, HL7468, Nimitz Hill, Guam, August 6, 1997*. Aircraft Accident Report NTSB/AAR-2000/01. Washington, DC.

about 3 miles southwest of the airport. Of the 254 persons on board, 228 were killed (including the three flight crewmembers), and 23 passengers and 3 flight attendants survived the accident with serious injuries. The airplane was destroyed by impact forces and a postcrash fire.

The accident happened after midnight in the flight crew's home time zone (0142 Guam local time). According to the final report on this accident, research has indicated that this time of day is often associated with degraded alertness and performance and a higher probability of errors and accidents. Also, the arrival time for flight 801 was several hours after the captain's (the flying pilot) normal bedtime. At the time of the accident, the captain had been awake for 11 hours,¹⁶¹ and the CVR recorded unsolicited comments made by the captain related to fatigue. The Safety Board concluded that the captain was fatigued, which degraded his performance and contributed to his failure to properly execute the approach.

The Safety Board determined that the probable cause of this accident was the captain's failure to adequately brief and execute the nonprecision approach and the flight crew's failure to effectively monitor and cross-check the captain's execution of the approach. Contributing to these failures were the captain's fatigue and Korean Air's inadequate flight crew training. Contributing to the accident was the FAA's intentional inhibition of the minimum safe altitude warning system at Guam and the agency's failure to adequately manage the system.

1.18.6.1 Previous Fatigue-Related Safety Recommendation

Since 1989, the Safety Board has issued at least 70 safety recommendations related to fatigue for all modes of transportation. In addition, human fatigue in transport operations has been included in the Board's annual list of Most Wanted Transportation Safety Improvements since the list's inception in September 1990. One recent aviation fatigue-related recommendation is detailed below.

A-99-45

In May 1999, the Safety Board adopted a safety report that evaluated the U.S. Department of Transportation's (DOT) efforts in the 1990s to address operator fatigue.¹⁶² In its report, the Board noted that in 1989 it issued three recommendations to the DOT addressing needed research, education, and revisions to hours-of-service regulations.¹⁶³ The Board stated that, even though the DOT and modal administrations had responded positively to the recommendations addressing research and education, little action had occurred with respect to revising the hours-of-service regulations.

¹⁶¹ The captain's wife indicated that, on August 5, 1997, he woke up about 0600 and took a nap between 1100 and 1340 (Seoul local time).

¹⁶² National Transportation Safety Board. 1999. *Evaluation of U.S. Department of Transportation Efforts in the 1990s to Address Operator Fatigue*. Safety Report NTSB/SR-99/01. Washington, DC.

The safety report discussed the activities and efforts by the DOT and the modal administrations to address operator fatigue and the resulting progress that has been made over the past 10 years to implement the actions called for in the Safety Board's fatigue-related recommendations. The report also provided background information on current hours-of-service regulations, fatigue, and the effects of fatigue on transportation safety. As a result of its findings, the Safety Board issued Safety Recommendation A-99-45, which asked the FAA to

Establish within 2 years scientifically based hours-of-service regulations that set limits on hours of service, provide predictable work and rest schedules, and consider circadian rhythms and human sleep and rest requirements.

On July 15, 1999, the FAA stated that, on December 11, 1995, it issued Notice of Proposed Rulemaking (NPRM) 95-18, "Flight Crewmember Duty Period Limitations, Flight Time Limitations and Rest Requirements." The NPRM proposed amending existing regulations to establish one set of duty period limitations, flight time limitations, and rest requirements for flight crewmembers involved in air transportation. The FAA stated that the NPRM considered scientific data from studies conducted by NASA relating to flight crewmember duty periods, flight times, and rest and that Safety Recommendation A-99-45 would be included in this rulemaking project. The FAA indicated that its Aviation Rulemaking Advisory Committee was tasked to review reserve issues related to the NPRM but was unable to agree on a recommendation. The FAA further indicated that it was conducting a risk assessment to determine the probability of preventing future incidents related to fatigue and did not know when a supplemental NPRM would be issued. In addition, the FAA stated that, on June 15, 1999, it published a Notice of Intent in the *Federal Register* to indicate the agency's intent to enforce regulations concerning flight time limitations and rest requirements.

On January 3, 2000, the Safety Board stated that it was pleased that the FAA would include this safety recommendation in any future action regarding NPRM 95-18 and that the FAA was committed to enforcing its existing regulations. However, the Board indicated that it was disappointed that, even though the NPRM was issued over 4 years earlier, the existing regulations had not been upgraded. Also, the Board indicated that it

¹⁶³ Safety Recommendation I-89-1 asked the DOT to expedite a coordinated research program on the effects of fatigue, sleepiness, sleep disorders, and circadian factors on transportation system safety. Safety Recommendation I-89-2 asked the DOT to develop and disseminate educational material for transportation industry personnel and management regarding shift work; work and rest schedules; and proper regimens of health, diet, and rest. Safety Recommendation I-89-3 asked the DOT to review and upgrade regulations governing hours of service for all transportation modes to ensure that they are consistent and that they incorporate the results of the latest research on fatigue and sleep issues. Safety Recommendations I-89-1 and -2 were classified "Closed—Acceptable Action" on July 19, 1996, and May 25, 2001, respectively. Safety Recommendation I-89-3 was classified "Closed—Unacceptable Action/Superseded" with the issuance of Safety Recommendation I-99-1, which asked the DOT to "require the modal administrations to modify the appropriate *Codes of Federal Regulations* to establish scientifically based hours-of-service regulations that set limits on hours of service, provide predictable work and rest schedules, and consider circadian rhythms and human sleep and rest requirements. Seek Congressional authority, if necessary, for the modal administrations to establish these regulations." The Safety Board classified Safety Recommendation I-99-1 "Open—Acceptable Response" on December 4, 2000.

wanted to understand the FAA's rationale for a supplemental NPRM. In addition, at an October 7, 1999, meeting to discuss aviation issues on the Board's list of Most Wanted Transportation Safety Improvements, FAA representatives said that the FAA would not be able to meet the specified 2-year timeframe for a new rule.

On December 5, 2000, the FAA stated that it planned to issue a supplemental NPRM that would address the technical and operational concerns that were raised during the NPRM comment period. According to the FAA, the supplemental NPRM would prescribe "a maximum duty period linked to a maximum flight time restriction that is associated with a minimum rest period based on the number of pilots." Also, the FAA indicated that the supplemental NPRM, which was expected to be issued by spring 2001, would address the issue of fatigue "concretely" and give the airlines the flexibility they need to operate. The FAA further indicated that it would have to issue a supplemental NPRM rather than a final rule because of the numerous comments that were received as a result of NPRM 95-18.

On April 26, 2001, the Safety Board indicated that it was frustrated by the FAA's lack of progress concerning this safety issue. The Board stated that, in the 5 years since the issuance of NPRM 95-18 and the 1 1/2 years since the need for a supplemental NPRM was first communicated, the FAA has not taken action. The Board urged the FAA to expeditiously complete action to develop and implement flight and duty regulations. Pending the issuance of the supplemental NPRM and expeditious action to implement a final rule, Safety Recommendation A-99-45 was classified "Open—Unacceptable Response."

1.18.6.2 Additional Fatigue Information

On April 28, 2000, a fatigue researcher from the University of Pennsylvania School of Medicine was interviewed as part of the investigation of the flight 1420 accident.¹⁶⁴ The researcher stated that the term "fatigue" generally refers to an individual's difficulty maintaining a certain level of performance as a function of time. The researcher described how fatigue could affect human performance. For example, individuals who are fatigued tend to have decreased vigilance in tasks that require monitoring or detecting signals and increased short-term and working memory errors. Also, individuals who are fatigued tend to keep trying one specific solution to a situation even if it no longer works, take more risks (that is, cut corners and accept lower standards), and pay less attention or not be aware of peripheral events.

The fatigue researcher reviewed factual documents related to the flight 1420 accident. He stated that, because the accident happened a couple of hours after the captain's usual bedtime, his circadian system was already in a downward phase. The professor indicated that the captain could have been feeling "pretty good" and "alert"

¹⁶⁴ The fatigue researcher is a Professor of Psychology in the Department of Psychiatry and the Chief of the Division of Sleep and Chronobiology at University of Pennsylvania School of Medicine. He also directs the Unit for Experimental Psychology, a laboratory that conducts research studies related to alertness and performance capabilities in individuals who work long or unusual hours.

when he left Dallas but that he could have experienced “an increased physiologic fatigue level” as he began to approach Little Rock. The researcher further indicated that the captain’s total time awake (over 16 hours) might have made him more vulnerable to making errors. In addition, he stated that the captain’s prolonged wakefulness and the time of the accident (compared with his usual bedtime) made it “highly likely” that the captain was fatigued at the time of the crash.

1.18.7 Other Previous Related Accidents

1.18.7.1 Accidents Involving Rescue Efforts

The Safety Board has investigated or learned of accidents in which the survival of airplane occupants was aided by or was dependent on the ability of rescue personnel to enter an airplane to perform interior firefighting or remove a person to safety.¹⁶⁵ A brief discussion of three such accidents follows.

British Airtours Charter Flight, Manchester, England, August 22, 1985

On August 22, 1985, a British Airtours charter Boeing 737-226, G-BGJL, was taking off from Manchester International Airport, England, when an uncontained failure in the left engine occurred.¹⁶⁶ The wing fuel tank was punctured, which led to a fuel-fed fire. The flight crew abandoned the takeoff immediately and ordered the evacuation of the passengers through the exits on the right side of the airplane. By the time the airplane had come to a stop, fire had penetrated the hull, and smoke had entered the cabin. Of the 6 crewmembers and 131 passengers aboard the airplane, 55 were killed, 15 were seriously injured, and 67 received minor injuries or were not injured. The airplane was destroyed. About 5 1/2 minutes after the airplane had stopped, a 14-year-old boy was pulled out of the right overwing exit by a firefighter. He was the last evacuee to survive the accident.

Horizon Air Flight 2638, Seattle, Washington, April 15, 1988

On April 15, 1988, Horizon Air flight 2638, a DeHavilland DHC-8, N819PH, had departed from Seattle-Tacoma International Airport when the right engine lost power.¹⁶⁷ The flight crew decided to return to the airport for a precautionary landing. As the landing

¹⁶⁵ The Safety Board had previously commented on the need for additional ARFF resources. Specifically, in an August 1996 letter to the FAA, the Board commented on its review of the FAA’s draft report, *Aircraft Rescue and Firefighting Services—Mission Response Study*. The Board stated that the mission set forth in 14 CFR Part 139 for ARFF personnel to “provide an escape path from a burning airplane” was no longer sufficient and that it supported a broader mission in which adequate ARFF resources would be available “to rapidly extinguish interior fires and extricate aircraft occupants from such interior fires.”

¹⁶⁶ For more information, see *Air Accidents Investigation Branch. Report on the Accident to Boeing 737-236 Series 1, G-BGJL, at Manchester International Airport on 22 August 1985*, Aircraft Accident Report 8/88. Farnborough, England.

¹⁶⁷ For more information, see National Transportation Safety Board. *Horizon Air, Inc., DeHavilland DHC-8, Seattle-Tacoma International Airport, Seattle, Washington, April 15, 1988*. Aircraft Accident Report NTSB/AAR/89-02. Washington, DC.

gear was lowered, a fire broke out in the right engine nacelle. The engine was then shut down. After the airplane landed, almost all of the directional control and braking capability had been lost. The airplane departed the paved surface of the runway and struck several objects on a paved ramp area. Of the 40 airplane occupants, 4 received serious injuries, and 36 received minor or no injuries. The airplane was destroyed by the fire and impact. Firefighters entered the cabin and extricated two passengers who were trapped by wreckage—one of whom had a lacerated aorta—and assisted other airplane occupants, including the captain and the first officer, off the airplane. The Safety Board determined that the firefighters' rescue of the passenger with a lacerated aorta (which occurred before the fire was extinguished) was "instrumental" in saving his life.

USAir Flight 1493/Skywest Flight 5569, Los Angeles, California, February 1, 1991

On February 1, 1991, USAir flight 1493, a Boeing 737-300, N388US, and Skywest Flight 5569, a Fairchild Metroliner SA-227-AC, N683AV, collided on runway 24L at Los Angeles International Airport, California.¹⁶⁸ The USAir airplane was landing, and the Skywest airplane was positioned on the same runway awaiting clearance for takeoff. There was an explosion and fire upon impact, and the two airplanes slid into an unoccupied fire station. Of the 95 airplane occupants aboard the USAir airplane, 22 were killed, 13 were seriously injured, 15 received minor injuries, and 37 were uninjured. All of the 12 occupants aboard the Skywest airplane were killed. Both airplanes were destroyed by impact forces and postcrash fire.

Firefighters assisted some passengers in evacuating the 737. One of the firefighters removed the first officer from the wreckage and, with the help of another firefighter, moved him to a safe area. Also, firefighters brought hand lines into the airplane, including one firefighter who brought a hand line to the cockpit to protect the captain from fire (he was pinned in the wreckage and appeared lifeless).¹⁶⁹ The firefighters remained in the cabin until the interior fire was extinguished. The Safety Board's final report stated that "the rapid availability of adequate numbers of ARFF-trained firefighters...allowed ARFF personnel to implement an interior fire attack immediately."

1.18.7.2 Accidents Involving Delayed Emergency Response

The Safety Board has investigated accidents in which the emergency response was delayed because the crash was not detected or the wreckage was not located in a timely manner. A brief discussion of three such accidents follows.

Northwest Airlines Flights 1482 and 299, Detroit, Michigan, December 3, 1990

¹⁶⁸ For more information, see National Transportation Safety Board. *Runway Collision of USAir Flight 1493, Boeing 737, and Skywest Flight 5569, Fairchild Metroliner, Los Angeles International Airport, Los Angeles, California, February 1, 1991*. Aircraft Accident Report NTSB/AAR/91-08. Washington, DC.

¹⁶⁹ The first officer survived the accident. The captain died as a result of traumatic injury to the head.

On December 3, 1990, Northwest Airlines flight 1482, a Douglas DC-9-14, N3313L, and Northwest flight 299, a 727, N278US, collided near the intersection of two runways in dense fog at Detroit Metropolitan/Wayne County Airport, Romulus, Michigan.¹⁷⁰ Of the 40 passengers and 4 crewmembers aboard the DC-9, 8 were killed, 10 received serious injuries, and 26 received minor or no injuries. None of the 146 passengers and 8 crewmembers aboard the 727 were injured. The DC-9 was destroyed, and the 727 was substantially damaged. In its final report on the accident, the Safety Board stated that the low visibility and the lack of immediate, accurate location information available in the control tower resulted in the fire department being unable to locate the DC-9 until about 5 minutes after the collision. In addition, by the time the first ARFF vehicle reached the DC-9, its cabin was fully involved with fire. That ARFF vehicle, however, had no heavy fire-fighting equipment, so the driver had to radio the other units (which were responding to the 727) and request that they respond to the DC-9.

USAir Flight 1016, Charlotte, North Carolina, July 2, 1994

In the July 2, 1994, USAir flight 1016 accident in Charlotte, North Carolina, (previously discussed in section 1.18.5), the control tower's initial notification to the ARFF station was made about 2 minutes after the accident occurred. The initial notification, however, did not identify any specific location of the downed airplane because of the restricted visibility conditions. The fire trucks began to traverse the airport, in heavy rain, searching for the airplane. The controller then saw a large area of smoke and described the location to the ARFF units. The first ARFF unit arrived at the accident scene about 8 minutes after the accident.

American Airlines Flight 1340, Chicago, Illinois, February 9, 1998

On February 9, 1998, American Airlines flight 1340, a Boeing 727-223, N845AA, crashed 180 feet short of the runway 14R threshold at Chicago O'Hare International Airport.¹⁷¹ During the ground impact sequence, the main landing gear and aft air stairs separated from the airplane, and the nose gear folded back into the avionics compartment. The airplane came to rest on its fuselage 2,245 feet from the initial impact point. Of the 3 flight crewmembers, 3 flight attendants, and 116 passengers aboard the airplane, 1 flight attendant and 22 passengers received minor injuries. The airplane received substantial damage. A City of Chicago Department of Aviation vehicle radioed the control tower

¹⁷⁰ For more information, see National Transportation Safety Board. 1991. *Runway Incursion and Collision, Northwest Airlines, Inc., Flights 1482 and 299, Detroit Metropolitan/Wayne County Airport, Romulus, Michigan, December 3, 1990*. Aircraft Accident Report NTSB/AAR/91-05. Washington, DC.

¹⁷¹ The description for this accident, DCA98MA023, can be found on the Safety Board's Web site at <<http://www.nts.gov>>.

about 5 minutes after the accident had occurred, informing the local controller that an airplane was down and that debris was on the runway. Until that point, the controller was not aware that flight 1340 had crashed.¹⁷² Fire department personnel arrived at the accident scene 2 minutes after receiving notification, which was about 7 minutes after the accident.

1.18.8 Other Previous Related Safety Recommendations

1.18.8.1 Aircraft Operations in the Airport Environment

A-94-211

On April 27, 1994, Action Air Charters flight 990, a Piper PA-31-350 Navajo Chieftain, N990RA, crashed into a blast fence at the end of runway 6 at Sikorsky Memorial Airport, Stratford, Connecticut.¹⁷³ Nine airplane occupants were killed, and one was seriously injured.¹⁷⁴ The airplane was destroyed by impact forces and a postcrash fire. As a result of this accident, the Safety Board issued Safety Recommendation A-94-211 on December 13, 1994, which asked the FAA to

Inspect all 14 CFR Part 139 certificated airports for adequate runway safety areas and nonfrangible objects, such as blast fences, and require that substandard runway safety areas be upgraded to AC 150/5300-13 minimum standards wherever possible.

On October 15, 1997, the FAA indicated that it had conducted a study and found that 58 percent of the runways at 14 CFR Part 139 certificated airports have runway safety areas that meet this standard, 25 percent have safety areas that do not meet the standard but could with feasible improvements, and 17 percent have safety areas that could not be feasibly improved to meet the standard. The FAA stated that runway safety area improvement projects would be scheduled as part of overall runway improvement projects because of the associated cost and infrequency of aircraft overruns and undershoots. On February 10, 1999, the Safety Board classified Safety Recommendation A-94-211

¹⁷² Before he became aware of the crash, the controller had been clearing arriving aircraft for landing on the same runway. One airplane had completed a landing with the debris on the runway, and a second airplane had touched down momentarily on the runway while executing a go-around maneuver.

¹⁷³ National Transportation Safety Board. 1994. *Impact With Blast Fence Upon Landing Rollout, Action Air Charters Flight 990, Piper PA-31-350, N990RA, Stratford, Connecticut, April 27, 1994*. Aircraft Accident Report NTSB/AAR-94/08. Washington, DC.

¹⁷⁴ The blast fence was located 342 feet northeast of the runway 24 displaced threshold. The departure end of runway 6 (the approach end of runway 24) had no runway safety area. This runway was exempt from the standards in the FAA's June 5, 1991, version of AC 150/5300-13 (see section 1.10.1); otherwise, a runway safety area of 800 feet would have been required. In its final report on this accident, the Safety Board concluded that the destruction of the airplane and the resulting occupant injuries were a direct result of the airplane's collision with the blast fence but that the crash forces resulting from the collision were survivable (the nine fatalities resulted from smoke inhalation and/or thermal injuries).

“Closed—Unacceptable Action” because runway safety area upgrades might be delayed by many years, allowing nonstandard conditions to continue.

A-84-36

The Safety Board conducted a special investigation in response to three accidents in 1982 that involved long-standing concerns regarding the safety of aircraft operations in the airport environment.¹⁷⁵ On April 16, 1984, the Board issued Safety Recommendation A-84-36, which asked the FAA to

Initiate research and development activities to establish the feasibility of submerged low-impact resistance support structures for airport facilities and promulgate a design standard if such structures are found to be practical.

On October 30, 1996, the FAA stated that it and the National Institute of Standards and Technology studied the feasibility of submerged low-impact structures and concluded that, with the technology currently available, any structure deemed frangible would most likely be destroyed by wave motion produced by small storms. On the basis of the FAA’s actions, the Safety Board classified Safety Recommendation A-84-36 “Closed—Acceptable Action” on December 20, 1996.

1.18.8.2 Stabilized Approach Guidance

A-97-85

On October 19, 1996, Delta Air Lines flight 554, an MD-88, N914DL, struck the approach lighting structure at the end of the runway deck during an approach to runway 13 at LaGuardia Airport, Flushing New York.¹⁷⁶ The 2 flight crewmembers, the 3 flight attendants, and 55 passengers were not injured; 3 passengers received minor injuries. The airplane was substantially damaged. In its final report on this accident, the Safety Board stated that Delta’s manuals did not specify operational criteria for a stabilized approach or contain procedural guidance for pilots to follow if an approach became unstabilized. The Board concluded that the lack of guidance on the stabilized approach concept did not contribute to the accident. However, the Board was concerned that, if Delta’s manuals at the time of the accident contained inadequate information on stabilized approaches, other air carriers’ guidance might also be inadequate. As a result, the Board issued Safety Recommendation A-97-85, which asked the FAA to

¹⁷⁵ These accidents were Air Florida flight 90 near Washington National Airport, January 13, 1982; World Airways flight 30H at Boston Logan International Airport, January 23, 1982; and Pan American World Airways flight 759 near New Orleans International Airport, July 9, 1982.

¹⁷⁶ National Transportation Safety Board. 1997. *Descent Below Visual Glidepath and Collision With Terrain, Delta Air Lines Flight 554, McDonnell Douglas MD-88, N914DL, LaGuardia Airport, New York, October 19, 1996*. Aircraft Accident Report NTSB/AAR-97/03. Washington, DC.

Require all 14 CFR Part 121 and 135 operators to review and revise their company operations manuals to more clearly delineate flight crewmember (pilot flying/pilot not flying) duties and responsibilities for various phases of flight and more clearly define terms that are critical for safety-of-flight decision-making, such as “stabilized approach.”

On June 26, 1998, the FAA stated that it issued Flight Standards Handbook Bulletin for Air Transportation 98-22, “Stabilized Approaches,” on May 26, 1998. The bulletin directed 14 CFR Part 121 and 135 POIs to review operators’ training and operations manuals to ensure that the stabilized approach concept was addressed. The POIs were also to ensure that the manuals contained the minimum requirements for a stabilized approach, the immediate actions that needed to be taken if the stabilized approach conditions were not met, and the flying and nonflying pilots’ responsibilities during the approach phase of flight. On the basis of the FAA’s actions, the Safety Board classified Safety Recommendation A-97-85 “Closed—Acceptable Action” on November 20, 1998.

1.18.8.3 Manufacturer’s Operating Information

A-98-102

On January 9, 1997, Comair flight 3272, an Embraer EMB-120RT, N265CA, crashed during a rapid descent after an uncommanded roll excursion near Monroe, Michigan.¹⁷⁷ The 2 flight crewmembers, 1 flight attendant, and 26 passengers were killed, and the airplane was destroyed by impact forces and a postcrash fire. In its investigation of this accident, the Safety Board concluded that the FAA’s policy of allowing air carriers to elect not to adopt airplane flight manual operational procedures without clear written justification could result in air carriers using procedures that may not reflect the safest operating practices. As a result, the Board issued Safety Recommendation A-98-102, which asked the FAA to

Require air carriers to adopt the operating procedures contained in the manufacturer’s airplane flight manual and subsequent approved revisions or provide written justification that an equivalent safety level results from an alternate procedure.

On September 16, 1999, the FAA stated that, on May 28, 1999, it issued Joint Flight Standards Handbook Bulletin for Air Transportation, Airworthiness, and General Aviation, Flight Standards Policy—Company Operating Manuals and Company Training Program Revisions for Compliance. According to the FAA, the bulletin directed that POIs encourage their operators to have a reliable delivery system in place for flight manual revisions, which ensures that the operators receive the revisions within 30 calendar days of approval, and develop an action plan to notify, in writing, respective POIs of new flight

¹⁷⁷ National Transportation Safety Board. 1998. *In-flight Icing Encounter and Uncontrolled Collision With Terrain, Comair Flight 3272, Embraer EMB-120RT, N265CA, Monroe, Michigan, January 9, 1997*. Aircraft Accident Report NTSB/AAR-98/04. Washington, DC.

manual revisions within 15 days after receipt. The FAA also stated that it was considering a regulatory change that would require the bulletin's safety policy to be mandatory.

On April 11, 2000, the Safety Board noted that the bulletin, although not regulatory in nature, was a positive step toward meeting the goals of the recommendation. On July 7, 2000, the FAA stated that it had initiated an NPRM proposing to revise 14 CFR Part 121, Subparts N and O, and that the policy included in the handbook bulletin would be reflected in the NPRM. On January 12, 2001, the Board acknowledged the FAA's actions and stated that, pending the issuance of the NPRM and the implementation of the proposed regulation, Safety Recommendation A-98-102 was classified "Open—Acceptable Response." On August 2, 2001, the FAA stated that it was continuing to develop the NPRM.

2. Analysis

2.1 General

The captain and the first officer of American Airlines flight 1420 were properly certificated and qualified under Federal and company requirements. No evidence indicated any preexisting medical or behavioral conditions that might have adversely affected the flight crew's performance during the accident flight.

The accident airplane was properly certified, equipped, and maintained in accordance with Federal regulations and approved company procedures. No evidence indicated preexisting engine, system, or structural failures.

This analysis focuses primarily on the flight crew's performance and the airplane's spoiler system. The flight crew's performance on approach to the airport is examined during three segments of the approach and in the context of the weather information and cues that were available. The flight crew's and the airplane's performance during the landing and overrun sequences are also examined. The analysis also addresses the roles of situational stress and fatigue in the accident sequence; meteorological support, including ATC services; emergency response efforts; airport issues; and American and FAA oversight.

2.2 Accident Scenario

2.2.1 The Approach

The flight crew had multiple sources of information indicating that thunderstorms might become a factor during the approach. The preflight weather package (discussed in section 1.7.3) included two NWS weather advisories for severe thunderstorms and a company SIGMEC [significant meteorological condition] for a widely scattered area of thunderstorms along the planned route. Also, the dispatcher's 2254 message via the aircraft communication addressing and reporting system informed the crew of the lines of thunderstorms to the left and right of the planned route and suggested that the crew expedite the arrival to the airport "to beat the thunderstorms." In addition, NWS Convective SIGMET [significant meteorological information] 15C, received about 2304, warned of a line of severe thunderstorms moving southeast through Arkansas with hail up to 2 inches in diameter and the possibility of wind gusts to 70 knots. Finally, automatic terminal information service (ATIS) information Romeo, which was current beginning about 2326, indicated that a thunderstorm with frequent lightning was located west through northwest of the airport and moving northeast.

The flight crewmembers also had weather information from the airborne weather radar and their view outside the cockpit. Statements from the CVR indicated that the flight crew had discussed the weather and the need to expedite the approach. For example, at 2325:47, the captain said, “we got to get over there quick.” The first officer then stated, “I don’t like that...that’s lightning,” to which the captain replied, “sure is.” At 2328:30, the captain repeated, “we gotta get there quick.” At 2329:55, the first officer stated, “I say we get down as soon as we can.”

The CVR also indicated that the crew had the city of Little Rock and the airport area in sight by at 2326:59. Further, the CVR recorded the captain’s announcement to the passengers, beginning at 2327:31, that “quite a light show” was to the left of their course and that they would be passing the lightning on the way to Little Rock.

2.2.1.1 Descent Into the Terminal Area

At 2334:11, the local controller told the flight crew, upon initial contact, that a thunderstorm located northwest of the airport was “moving through the area now” and that the winds were from 280° at 28 knots gusting to 44 knots. Even though the flight crewmembers had previously discussed the need to expedite the approach because of the weather, the CVR indicated that they had not discussed the possibility that the thunderstorm might reach the airport before the flight landed. In a postaccident interview, the first officer stated that, during the descent, the weather appeared to be about 15 miles away from the airport and that he and the captain thought that there was “some time” to make the approach. At 2339:12, the first officer told the controller, “that storm is moving this way like your radar says it is but a little bit farther off than you thought.” At that point, flight 1420 was about 11 miles south of the airport. Figure 18 shows a map of the weather conditions at 2339:12 and flight 1420’s location. After receiving the controller’s next wind report (330° at 11 knots), the first officer indicated that the winds were “a little bit better” than they had been earlier.

Weather data obtained after the accident depicted the weather conditions in the area shortly before the time of the accident. For example, airport weather observation data showed that heavy rain—defined by the NWS as 0.03 inch of rain within 6 minutes—had begun falling at the airport by about 2338, 12 minutes before the accident. In addition, the National Lightning Detection Network detected 903 cloud-to-ground lightning strikes within 20 miles of the airport in the 15 minutes before the accident and 46 strikes within 5 miles of the airport in the 5 minutes before the accident; most of the strikes were located northeast, west, and southwest of the airport and along a line that was parallel to (and to the west of) flight 1420’s final approach path.

American’s policy did not prohibit flight crews from continuing an approach with thunderstorms in the terminal area as long as the crews ensured that their intended route was clear of the thunderstorms. During the descent into the terminal area, there was no evidence to indicate that the route was not clear. In public hearing testimony, the first officer stated that, during the descent, the weather was to the left and moving off to the right and that the airport looked clear. Thus, the Safety Board concludes that, during the

descent into the terminal area, the flight crewmembers could have reasonably believed that they could reach the airport before the thunderstorm.

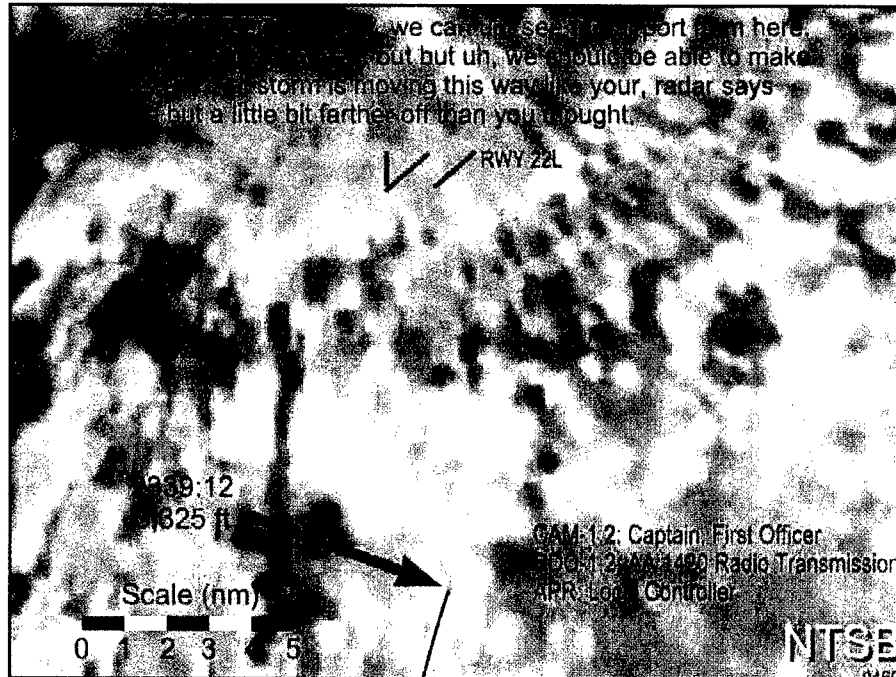

Figure 18. Weather and Flight Information for 2339:12

2.2.1.2 Maneuvering to the Airport for Final Approach

The flight crewmembers had been previously told by the controller to expect an instrument landing system (ILS) approach to runway 22L. At 2339:45, the local controller broadcast the first of two windshear alerts, reporting that the centerfield wind was 340° at 10 knots.¹⁷⁸ At this point, the airplane was about 8 miles from the airport. Afterward, the flight crew requested a change in runways from 22L to 4R because the winds had shifted to the northwest. The use of runway 22L could have resulted in a tailwind at the time of landing, so runway 4R was a more appropriate choice because of the expectation of a headwind. (NWS radar data indicated that the leading edge of a line of thunderstorms was over the airport at this time with the heaviest activity located northwest through northeast 5 miles from the runway.)¹⁷⁹ Figure 19 shows a map of the weather conditions at 2339:45 and flight 1420's location.

¹⁷⁸ The windshear alert also indicated that the north boundary wind was 330° at 25 knots and that the northwest boundary wind was 010° at 15 knots.

¹⁷⁹ The leading edge is one of the most hazardous areas in thunderstorms because of the updraft-downdraft interaction.

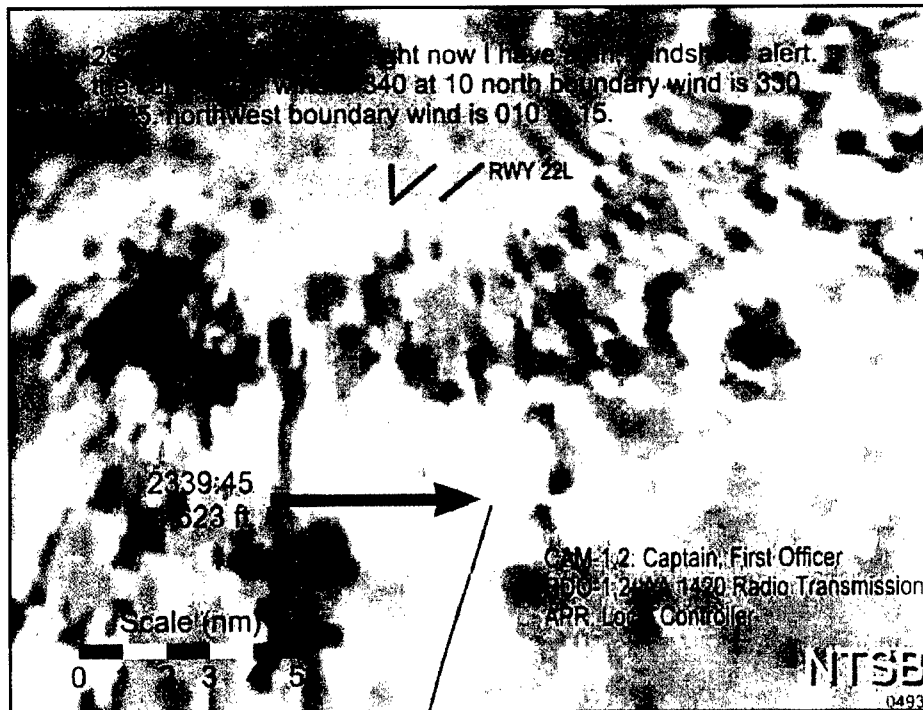

Figure 19. Weather and Flight Information for 2339:45

The controller instructed the flight crew to turn right to a heading of 250° for vectors to the runway 4R approach course. The right turn, which routed the airplane away from the airport, was necessary because the airplane was only about 4 miles southeast of runway 4R/22L. However, the turn, and the subsequent maneuvering south of the airport, meant that the flight crew had temporarily lost its ability to use the airborne weather radar (because of its forward-looking design) to monitor the storm's intensity and location relative to the airport. The flight crew would regain the use of the airborne weather radar to evaluate the storm and its location relative to the airport when the airplane turned back toward the airport to intercept the final approach course for runway 4R. However, until the airplane completed its base-to-final turn and leveled off, the radar data would have likely been difficult to interpret, especially for detecting features in the direction of the turn. (Thus, for about 7 minutes, the crew did not have precise information from the airborne weather radar about the location of the storm relative to the airport.)

After the runway change from 22L to 4R, the CVR recorded the first officer performing an abbreviated briefing for the newly assigned runway.¹⁸⁰ This briefing consisted of the localizer frequency and course, the minimum safe altitude, the missed approach procedure, and the decision altitude. Regarding the missed approach procedure,

¹⁸⁰ Although American's flight manual states that the captain is to ensure that a briefing is conducted before every approach, it does not contain any procedure for performing an abbreviated briefing for an instrument approach to a changed runway. The first officer stated in a postaccident interview that the captain conducted a formal briefing for runway 22L. The CVR recording did not include an approach briefing for runway 22L, but it is possible that the briefing occurred before the beginning of the recording at 2319:44.

the CVR recorded the first officer's statement, "missed approach right turn to four thousand," followed immediately by an unintelligible comment. The Jeppesen approach plate for the airport indicated that the right turn at 4,000 feet was to be accomplished via a 110° heading. The Safety Board could not conclusively determine whether the first officer briefed that part of the missed approach procedure. However, the CVR contained no discussion between the flight crewmembers about the missed approach procedure in relation to the location of the storm, specifically, that the right turn would maneuver the airplane clear of the weather.

The flight crew continued to receive, but did not discuss, wind reports from the controller. The flight crew's actions and conversations during this phase of the approach largely consisted of steps to expedite the approach to the airport. For example, at 2342:40, the first officer asked the captain if he wanted to conduct a "short approach" and "keep it in tight." The captain accepted the suggestion but with the qualification "if you see the runway, 'cause I don't quite see it." (The airport was off the right, or first officer's, side of the airplane.) The first officer began to radio the controller at 2342:54 to suggest a visual approach but interrupted this transmission 1 second later when he stated to the captain, "it's going right over the...field." In a postaccident interview, the first officer indicated that he was referring to a temporary obstruction of his view of the airport because of clouds. The first officer's next transmission, 4 seconds later, informed the controller that "we got the airport" and that "we're going between clouds." Figure 20 shows a map of the weather conditions at 2342:55 and flight 1420's location.

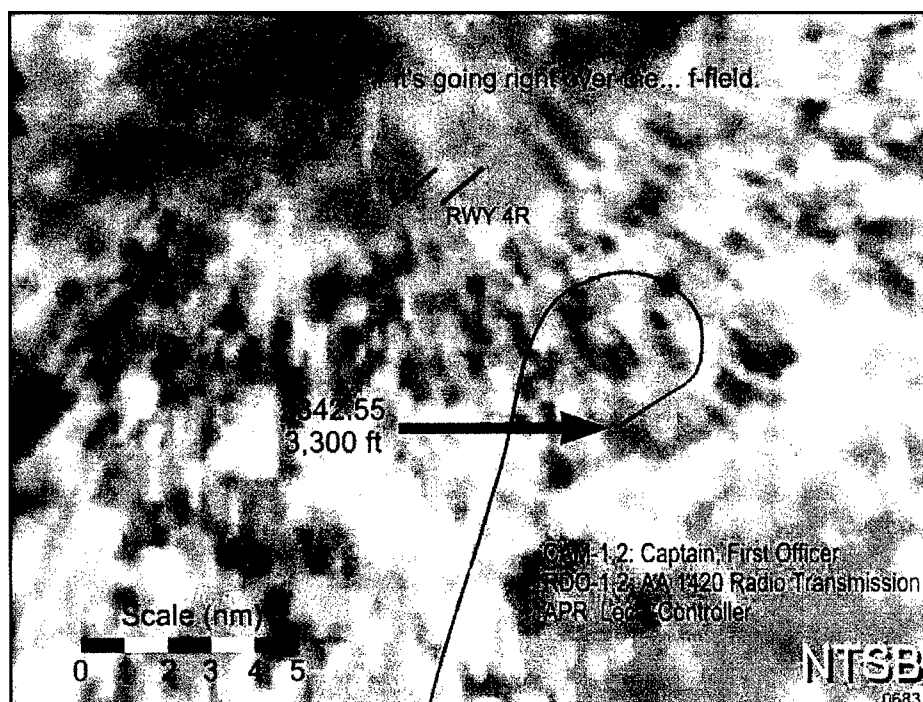

Figure 20. Weather and Flight Information for 2342:55

The controller offered the flight crew a visual approach to runway 4R, which the crew accepted. The CVR indicated that, during the attempted visual approach, the captain could not see the airport and was relying on the first officer to guide him toward the airport.¹⁸¹ The airplane's position (that is, its orientation, proximity, and altitude) relative to the airport likely made visual contact with the airport environment difficult for the captain.

At 2344:19, the captain stated, "see we're losing it. I don't think we can maintain visual." The first officer notified the controller at 2344:30 that visual contact with the airport had been lost because of a cloud between the airplane and the airport. The controller then cleared the airplane to fly a heading of 220° for radar vectors for the ILS approach to runway 4R. (ATC radar indicated that, at this time, flight 1420 was about 6 miles south of runway 4R, heading westbound and away from the runway. Weather radar data indicated that heavy rain was occurring at the airport at the time that the airplane was flying on the 220° heading.) Figure 21 shows a map of the weather conditions at 2344:30 and flight 1420's location.

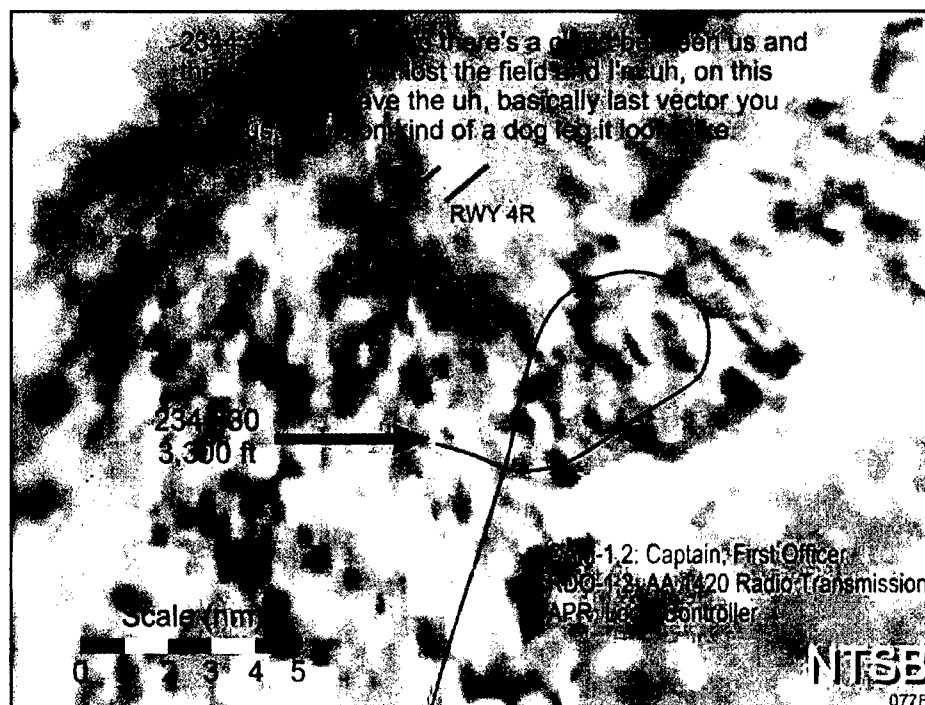

Figure 21. Weather and Flight Information for 2344:30

¹⁸¹ At 2343:26, the first officer said, "...there's the airport right there. Okay?" Five seconds later, the captain asked, "where?" At 2343:31, the first officer said, "okay, you're set up on a base for it. Okay?" to which the captain questioned, "I'm on a base now?" At 2343:35, the first officer said, "well, you're on a dog leg. You're comin' in. There's the airport." Three seconds later, the captain said, "I lost it," and the first officer said, "right there, you're you're downwind. See it's right there." The captain then said, "I still don't see it...well just vector me. I don't know."

The weather south of the airport became the next focus of the flight crew's attention. NWS radar data indicated that, in the 6 minutes before the accident, a line of thunderstorms, with several large areas of intense and extreme activity, was encompassing the Little Rock airport area and runway 4R approach path. At 2345:47, the first officer told the controller "we're getting pretty close to this storm. we'll keep it tight if we have to." The controller indicated to the flight crew that, "when you join the final, you're going to be right at just a little bit outside the marker if that's gonna be okay for ya." The captain stated, "that's great," and the first officer told the controller, "that's great with us." Figure 22 shows a map of the weather conditions at 2345:47 and flight 1420's location.

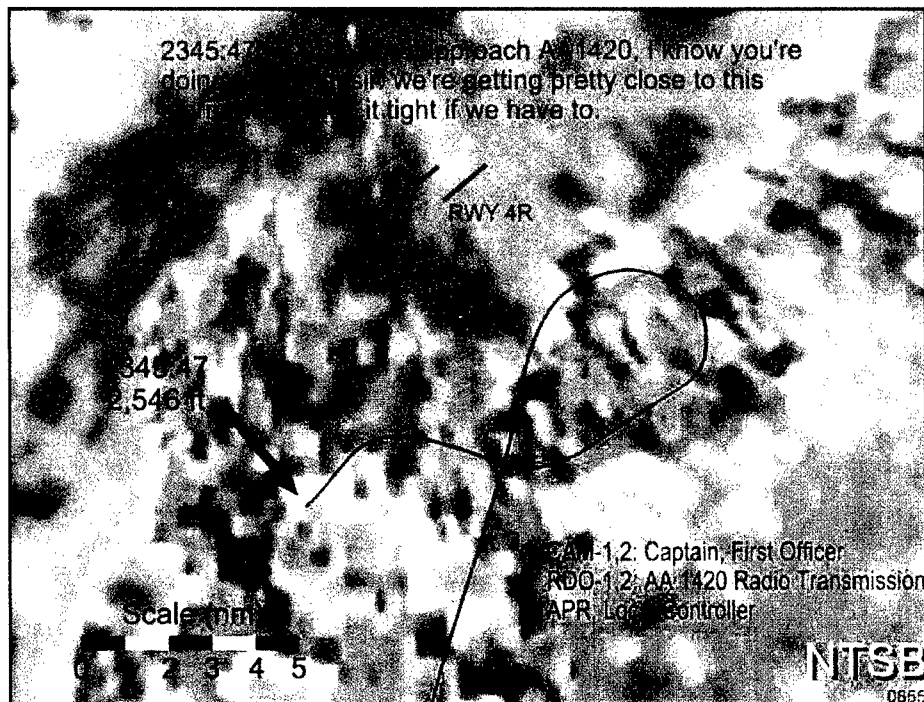

Figure 22. Weather and Flight Information for 2345:47

The airplane was once again turned westbound, and the controller provided the flight crew with heading instructions to position the airplane to intercept the runway 4R final approach course. At 2346:39, the controller informed the flight crew that the airplane was 3 miles from the outer marker, instructed the crew to maintain 2,300 feet until the airplane was established on the localizer, and cleared the crew for the runway 4R ILS approach. In a postaccident interview, the first officer stated that, at this point, there was urgency to land because the weather was "up against" the airport. However, the first officer also stated that, after being vectored to the runway 4R ILS approach course, he had visual contact with the runway throughout the rest of the approach.

At 2346:52, the controller advised the flight crew that heavy rain was falling at the airport, visibility was less than 1 mile, ATIS information Romeo was no longer current, and the runway visual range (RVR) was 3,000 feet. Simultaneously, the captain stated, "aw, we're goin' right into this." Figure 23 shows a map of the weather conditions at

2346:52 and flight 1420's location. About this point in the approach, the flight crew should have regained the use of the airborne weather radar to depict precipitation levels in front of the airplane. However, the Safety Board could not determine whether the radar was displaying this information or whether the flight crewmembers, given their workload, were able to perceive and interpret the information that the radar was providing.

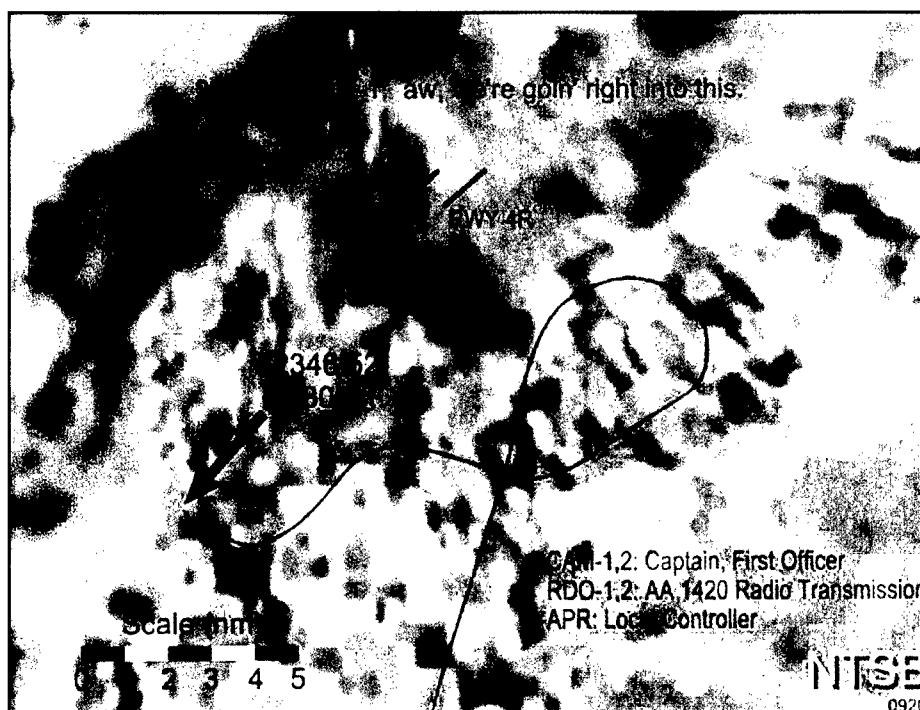

Figure 23. Weather and Flight Information for 2346:52

At 2347:08, the controller cleared flight 1420 to land and stated that the wind was 350° at 30 knots gusting to 45 knots. The CVR indicated that flight crew did not discuss the wind information, the heavy rain that was already falling at the airport, or the depiction of the weather on the airborne weather radar. Figure 24 shows a map of the weather conditions at 2347:08 and flight 1420's location.

Statements from the CVR and the first officer's postaccident interviews indicated the flight crew's concern about the location of the thunderstorm in relation to the airport and the airplane. However, the Safety Board concludes that, because the first officer was able to maintain visual contact with the runway as the airplane was vectored for the final approach course, both flight crewmembers might still have believed that flight 1420 could arrive at the airport before the thunderstorm. The Board understands that some other flight crews might continue an approach to a runway under the same circumstances. On the other hand, the Board also recognizes that the approaching storm and the reports of heavy rain, dropping visibility, and increasing crosswinds (from 10 to 30 knots with gusts to 45 knots) would be sufficient for some flight crews to hold until the storm passed or proceed to an alternate airport.

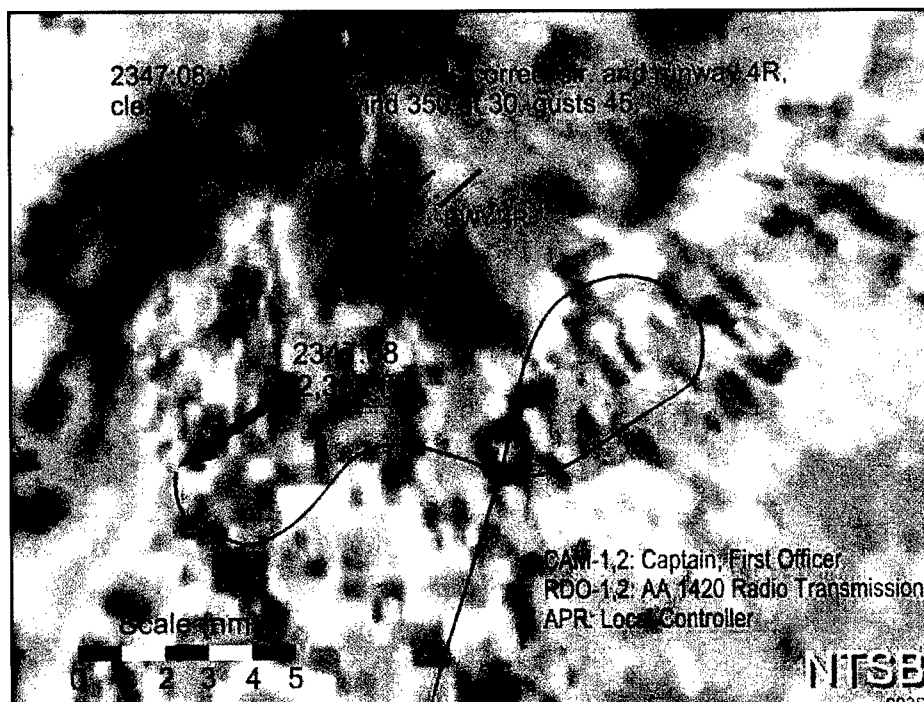

Figure 24. Weather and Flight Information for 2347:08

2.2.1.3 Final Approach Segment

The final approach segment began when the airplane intercepted the localizer, at 2347:16. Simultaneously, the first officer erroneously read back the controller's previous wind report of 350° at 30 knots gusting to 45 knots as "zero three zero at four five." The flight crew then discussed the effect of the previously reported RVR on the approach. The captain stated, "three thousand RVR. we can't land on that." The first officer then correctly told the captain that the approach required a 2,400-foot RVR, and the captain said, "ok, fine."

The CVR contained no discussion between the flight crew about the fact that the winds reported by the controller exceeded the company's maximum crosswind component for wet runways and the prevailing RVR. According to American's flight manual, the maximum crosswind component for a DC-9 landing on a runway with an RVR less than 4,000 feet was 15 knots. The latest winds reported by the controller resulted in a crosswind component of 23 knots for the steady-state wind and 34 knots for the gusting wind. Thus, the landing for runway 4R could no longer be conducted in accordance with company procedures. However, the flight crew likely did not recognize that an operational criterion for conducting the landing had been exceeded because the incorrect wind information read back by the first officer (030° at 45 knots) would have resulted in a crosswind component under 10 knots.

The CVR recorded the captain commanding the landing gear down at 2347:44. According to American's procedures, this callout indicated that the second half of the

Before Landing checklist—landing gear, spoiler lever, autobrakes, flaps and slats, and annunciator lights—was to be accomplished using a mechanical checklist in the cockpit (see section 1.17.3.2). The CVR recorded the sound of the landing gear being operated 2 seconds after the callout and the captain's statement "and lights, please" 5 seconds after the callout. The CVR indicated that, at this point in the approach, none of the remaining checklist items had been performed.

At 2347:53, the controller provided the flight crew with the second of the two windshear alerts, stating that the centerfield wind was 350° at 32 knots with gusts to 45 knots.¹⁸² The captain then indicated that he wanted 20 knots added to the approach speed.¹⁸³ There was no further discussion of the winds, which still exceeded American's maximum crosswind limitations for landing.¹⁸⁴ (NWS and ATC radar data indicated that, about this time, flight 1420 was on the leading edge of a line of thunderstorms.) The Safety Board concludes that, when the second windshear alert was received, the flight crew should have recognized that the approach to runway 4R should not continue because the maximum crosswind component for conducting the landing had been exceeded. Additionally, the flight crew should have recognized an apparent wind shift of 40° (a change from the mistaken 030° read back to the current 350° wind direction). This apparent wind shift should have given the flight crew the impression of an acutely changing weather situation, yet no related discussion was recorded on the CVR.

At 2348:12, the controller informed the flight crew that the RVR was 1,600 feet. This RVR reading further reduced the company's maximum crosswind component for landing to 10 knots, which was required when an RVR was less than 1,800 feet. However, the CVR still contained no discussion between the flight crew about the exceeded maximum crosswind component. During public hearing testimony, the first officer stated that he was still able to see the airport and that the RVR information provided by the controller "did not concur" with what he and the captain were seeing.

Because the maximum crosswind component had been exceeded, the landing on runway 4R would no longer be conducted in accordance with company procedures. However, the Federal Aviation Regulations did not prohibit the approach to the runway from continuing, even with weather that was below published minimums. Specifically, 14 CFR 121.651 (and American's flight manual) allowed the crew to continue to the decision height (200 feet afl, or 460 feet msl) because the airplane was already established on its final approach segment. After hearing that the runway 4R RVR had decreased to 1,600 feet, the captain stated, "well we're established on the final," and the first officer informed the controller that the airplane was "established inbound." The controller then cleared the flight crew to land and provided updated winds.

¹⁸² The windshear alert also indicated that the north boundary wind was 310° at 29 knots and that the northeast boundary wind was 320° at 32 knots.

¹⁸³ The former MD-80 Fleet Manager stated at the public hearing that, if a flight crew decided to continue an approach after receiving an LLWAS alert, he would expect the pilots to increase speed.

¹⁸⁴ In a postaccident interview, the first officer indicated that neither he nor the captain had checked the crosswind limitation in the flight manual. The first officer also indicated that he had started to look at his flight manual but that the captain had signaled him to put the manual away.

At this point in the approach, there were cues (for example, the heavy rain that was previously reported by the controller, the rapidly decreasing RVR, and the shifting and gusting winds) that the weather at and around the airport had deteriorated substantially. However, the CVR contained no discussion between the flight crewmembers about whether the approach should continue. In the Safety Board's judgment, the deteriorating weather conditions would have prompted some flight crews to abort the approach.

The CVR recorded the first officer's required announcement of the 1,000-foot altitude at 2348:50. At 2349:02, the first officer recognized that the final landing flap configuration had not been established and asked the captain whether he wanted landing flaps. The captain indicated that he thought he had already called for the landing flaps,¹⁸⁵ after which the first officer stated "forty now" and "forty forty land" to verify the flap/slat handle position, the flaps position indicator, and the illumination of the SLAT/LAND light. American's DC-9 Operating Manual stated that landing flaps are to be selected by 1,000 feet afl. The first officer indicated in a postaccident interview that he thought the airplane was about 900 feet afl when he selected the 40° final flap setting for landing, which was consistent with calculations based on FDR data. The CVR did not indicate any other Before Landing checklist callouts.

At 2349:10, the controller indicated that the winds were 330° at 28 knots. About 2 seconds later, the captain stated, "...this is a can of worms." FDR data indicated that the airplane was about 1,140 feet msl (880 feet afl) at this time and that the captain was making active control inputs to keep the airplane on the localizer and glideslope. Also, the FDR data showing fluctuating airspeed (± 5 knots, with one excursion to +8 knots and one to -10 knots) and vertical acceleration (± 0.2 G with occasional excursions to ± 0.25 G)¹⁸⁶ were consistent with the presence of gusty and turbulent winds. Figure 25 shows a map of the weather conditions at 2349:12 and flight 1420's location.

The first officer called the runway in sight at 2349:24, and the captain identified the runway about 7 seconds later. FDR data indicated that, at the time that the first officer called the runway in sight, the airplane's altitude was about 990 feet msl (730 feet afl), airspeed was 160 knots, glideslope deviation was 0.3 dot high, and localizer deviation was less than 0.1 dot to the left. FDR data also indicated that, at the time that the captain identified the runway, the airplane's altitude was 940 feet msl (680 feet afl), airspeed was 158 knots, glideslope deviation was 0.6 dot high, and localizer deviation was 0.1 dot to the left. At 2349:41, the CVR recorded a sound consistent with windshield wiper motion; the airplane's altitude at this time was about 820 feet msl (560 feet afl).

¹⁸⁵ The captain also did not call for flaps 28 earlier in the approach. The CVR indicated that, at 2348:03, the first officer had asked the captain, "flaps twenty eight?"

¹⁸⁶ G is a unit of measurement equivalent to the acceleration caused by the earth's gravity (32.174 feet/sec²).

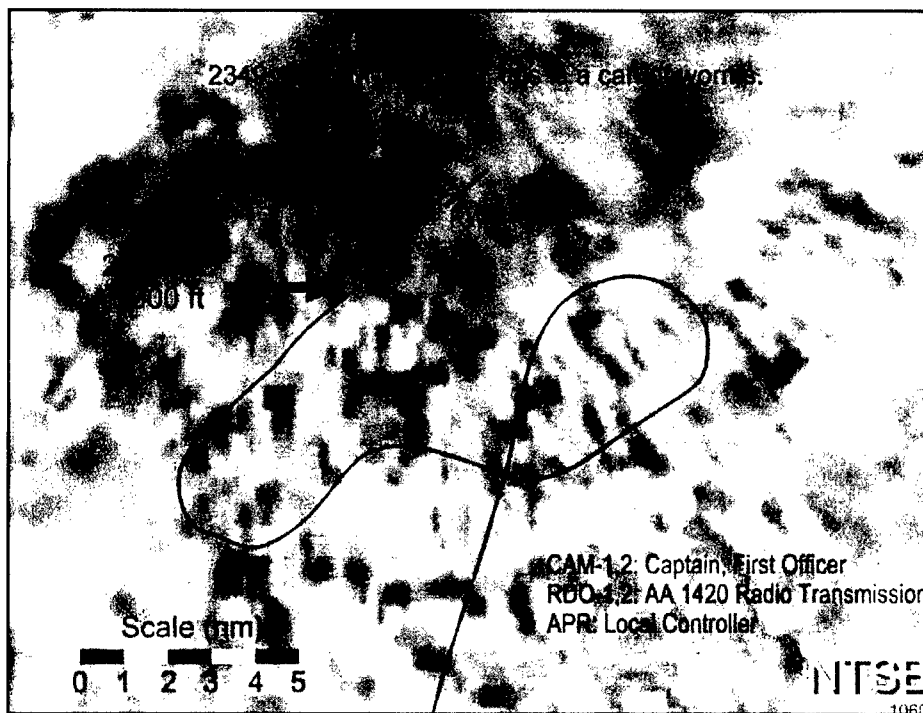

Figure 25. Weather and Flight Information for 2349:12

The first officer made his required 500-foot altitude callout at 2349:46. About 10 seconds later, an unidentified voice in the cockpit stated, "...we're off course." One second later, the CVR recorded an unintelligible statement made by an unidentified voice in the cockpit. In a postaccident interview, the first officer indicated that, about this time, he said quietly "go around." At 2350:00, the first officer stated, "we're way off." In a postaccident interview, the first officer indicated that he made this statement because the airplane was off the localizer and the right-side runway edge lights were drifting to his left. Calculations based on FDR data indicated that the airplane was about 477 feet msl (217 feet afl) and that the localizer deviation was between 0.9 and 1.0 dot to the right. As the airplane descended through the decision height (460 feet msl), the glideslope deviation was between 1.0 and 1.5 dots high and increasing.

American's DC-9 Operating Manual states that, on final approach, a callout will be made whenever either crewmember observes localizer displacement greater than 1/3 dot and/or glideslope displacement greater than 1/2 dot and that the other crewmember will acknowledge this deviation. FDR data indicated that the localizer and glideslope were both displaced in excess of these values, but the CVR contained no callout from either the captain or the first officer regarding the fact that the airplane was high on the glideslope and was to the right on the localizer. The first officer's statement, "we're way off," at 2350:00 (apparently in reference to the localizer displacement) was not a proper callout according to company procedures because it did not specifically inform the captain which ILS component was "off" and by what amount.

Although American's DC-9 Operating Manual instructed pilots to call out if the glideslope or localizer was displaced, the guidance did not indicate what displacement amount would result in an unstabilized approach and require a missed approach. In postaccident interviews, the MD-80 Fleet Manager and several check airmen explained that captains had the discretion to determine the maximum acceptable deviation from the glideslope or the localizer. (The adequacy of American's stabilized approach guidance is discussed in section 2.6.1.) In addition, FAA guidance on the stabilized approach concept in the Air Transportation Operations Inspector's Handbook does not provide any specific criteria for a stabilized approach; the guidance instead states that "operators of turbojet aircraft must establish and use procedures which result in stabilized approaches" (see section 1.17.3.4).¹⁸⁷ Thus, the Safety Board was not able to gauge whether the flight 1420 approach was considered unstabilized according to company procedures or FAA guidance.

At 2350:02, the captain stated, "I can't see it." Calculations based on FDR data indicated that the airplane was between 5 and 20 feet above the decision height at that time. The Safety Board was not able to determine whether the captain's comment referred to his loss of visual contact with the runway or with its environment. Figure 26 shows a map of the weather conditions at 2350:02 and flight 1420's location.

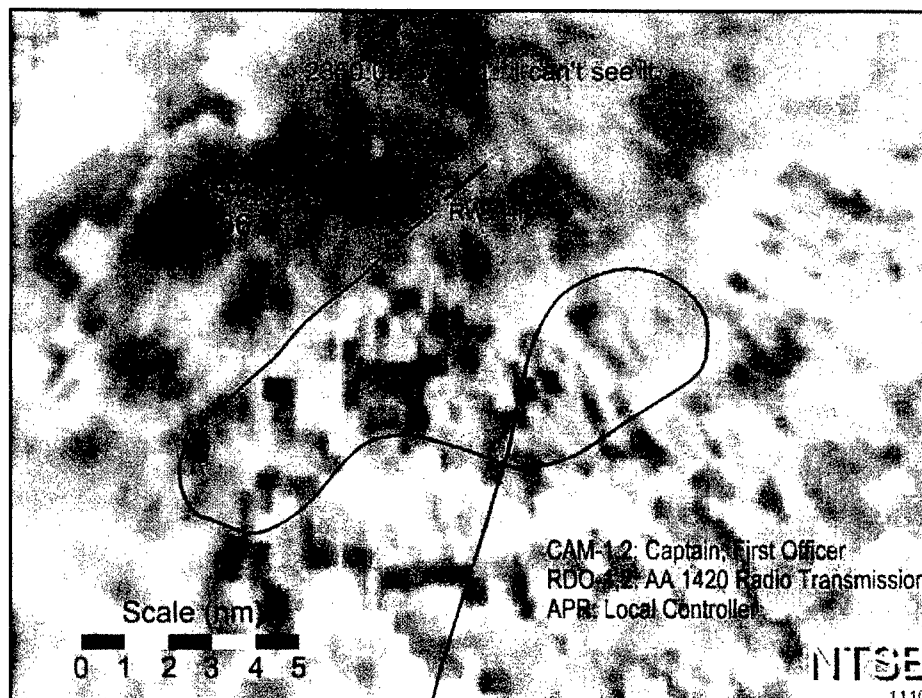

Figure 26. Weather and Flight Information for 2350:02

¹⁸⁷ The Safety Board notes that the FAA's guidance does provide general parameters and that American based its stabilized approach guidance on these parameters rather than specific ones.

Title 14 CFR 121.651 (c)(3) and American's DC-9 Operating Manual allow a pilot to continue an approach below the decision height if a visual reference for the intended runway is "distinctly visible and identifiable." Such references include the approach lighting system; the runway threshold or its markings; and the runway, its markings, or its lights. At 2350:05, the captain stated, "I got it"; calculations based on FDR data indicated that the airplane was between 10 and 30 feet below the decision height at the time. However, the Safety Board could not determine whether the captain's comment referred to the runway or to its environment and the altitude at which the captain regained visual contact. Further, the Board could not determine what altitude would have been displayed on the altimeters as the airplane descended below the decision height.¹⁸⁸

At 2350:11, the first officer made his required 100-foot callout. The CVR then recorded the airplane's GPWS announcement of the first of two sink rate alerts about 2350:13. FDR data indicated that the airplane was about 330 feet msl (70 feet afl) at the time. The second sink rate alert was recorded about 1 second later, and FDR data indicated that the airplane was about 310 feet msl (50 feet afl) at the time. These alerts indicated that the airplane's air data computer system was computing rates of descent that exceeded predetermined thresholds. The first officer made his required 50-, 40-, 30-, 20-, and 10-foot callouts between about 2350:13 and 2350:18, and the captain continued the approach to a landing.

2.2.1.4 Summary of the Flight Crew's Performance During the Approach

As the flight crew was maneuvering the airplane for landing, there were events that, individually, might not necessitate aborting an approach: a runway change because of a shifting wind, a failed visual approach to the newly assigned runway, the temporary inability of the airborne weather radar to show the weather conditions at the airport because of the airplane's direction of travel, the controller's report of the second part of the thunderstorm moving through the airport area, and the acceptance of a short approach near the outer marker because of the airplane's location in relation to the storm. However, these events, collectively, should have heightened the crewmembers' awareness that they might not be able to safely continue the approach. Thus, it would have been appropriate for the flight crew to have discussed specific options (holding, diverting to one of the two alternate airports, or performing a missed approach after the airplane was established on the final approach segment) in the event that the weather would necessitate aborting the approach later.¹⁸⁹

As the airplane intercepted the ILS final approach course for runway 4R, the flight crew entered an event-dependent, high workload phase of flight. Under normal conditions, tasks during this phase of flight include controlling and maneuvering the airplane,

¹⁸⁸ Flight 1420 received an altimeter setting of 29.86 inches of Hg. An altimeter with this setting and zero instrument error would display an altitude that was about 55 feet lower than the airplane's actual altitude during the final approach segment. However, because the Federal Aviation Regulations (14 CFR Part 43, Appendix E) allow instrument error of up to ± 75 feet, the altimeters could have been reading up to 20 feet higher than the airplane's actual altitude.

¹⁸⁹ The Safety Board notes that the airplane would have had an adequate fuel supply for each of these options.

configuring the airplane to land, performing final landing checks, and evaluating the airplane's performance relative to the landing criteria. In this case, the flight crew's earlier decision to accept a short approach increased the crew's already high workload by compressing the amount of time that was available to accomplish required tasks. In fact, the first officer highlighted this issue at the public hearing when he stated, "I remember around the time of making that base-to-final turn, how fast and compressed everything seemed to happen."

During the final approach, the flight crew had a significant amount of weather information that had to be simultaneously evaluated. This information included the controller's previous report of heavy rain at the airport with visibility less than 1 mile, the second windshear alert,¹⁹⁰ a rapidly decreasing RVR, and several wind reports. Under these circumstances, some flight crews would have decided to abandon the approach.

The flight 1420 crew then poorly performed, and did not complete, the second half of the Before Landing checklist. Although the sound of the landing gear being operated was recorded by the CVR, there is no CVR evidence to indicate that the first officer verbalized this checklist item as "down, three green" as required, which would have indicated that all three landing gear systems were in the down and locked position. Also, the captain commanded the 40° final landing flap configuration only after being queried by the first officer. As previously stated, the captain did not realize that he had not yet called for the flaps; as a result, this checklist item was performed late. In addition, there is no CVR evidence to indicate that the first officer called out that the spoiler lever was armed, checked the annunciator lights, and completed the Before Landing checklist or that either pilot had armed the spoiler lever and considered the use of automatic rather than manual braking in light of the deteriorating weather conditions.¹⁹¹

As previously discussed, the flight crew should have initiated a go-around during the final approach segment when a specific operational criterion was not met, that is, when the company's maximum crosswind component for conducting the landing was exceeded. The flight crewmembers' failure to establish the final landing flap configuration before reaching 1,000 feet afl and their failure to maintain a normal rate of descent, under different circumstances, might not necessitate a go-around. However, the Safety Board concludes that, because of the flight crew's failure to adequately prepare for the approach and the rapidly deteriorating weather conditions, the likelihood of safely completing the approach was decreasing, and the need to take a different course of action was progressively increasing; as a result, the flight crew should have abandoned the approach.

¹⁹⁰ Even though American's flight manual indicated that windshear alerts were advisory, its DC-9 Operating Manual instructed pilots to avoid areas of known severe windshear and search for clues to indicate the presence of severe windshear. The operating manual indicated that such clues included thunderstorm and convective clouds, rain showers, and strong or gusty surface winds. All of these conditions were present at some point and to some degree during flight 1420's approach to the airport.

¹⁹¹ The Safety Board notes that several events were competing for the first officer's attention at the time that he was performing the Before Landing checklist, as detailed in section 2.2.1.3. The Board further notes that, even though the first officer did not verbalize that the Before Landing checklist had been completed, as required, the CVR indicated that he did verbalize (early in the approach) that the Descent checklist had been completed.

Factors that contributed to the flight crew's performance during the accident flight are discussed in section 2.2.3.

Finally, it is important to note that a microburst, with a peak wind gust of 76 knots and rainfall rates of 9 inches per hour, impacted the airport shortly after the flight 1420 accident and thus was not a factor. NWS radar data, however, detected that the microburst was over runway 4R at 2353:00. Thus, if flight 1420's takeoff, en route flight, or approach to landing had been delayed by less than 2 minutes, the flight could have encountered the microburst on final approach. Microbursts can result in vertical and horizontal windshear that can be extremely hazardous to aircraft, especially at low altitudes, as demonstrated by the 1994 USAir flight 1016 accident in Charlotte, North Carolina, and the 1985 Delta Air Lines flight 191 accident in Dallas, Texas (see section 1.18.5). As a result, the Safety Board is concerned that the flight crew was operating in an environment that was conducive to microburst conditions.¹⁹² Section 2.2.3.1.1 presents an industry-wide recommendation to develop operational strategies and guidance to promote better flight crew decision-making regarding the penetration of severe convective activity.

2.2.2 The Landing

Flight 1420 touched down on runway 4R at 2350:20 at a speed of 160 knots. The airplane touched down about 2,000 feet down the 7,200-foot runway, slightly to the right of the centerline and sliding to the right. According to calculations based on FDR data, the airplane was subjected to a 5-knot tailwind component upon touchdown and a 20- to 25-knot left-to-right crosswind component during the landing.

The NWS' Automated Surface Observing System (ASOS) weather data indicated that surface winds from 290° at 16 knots gusting to 22 knots were present about the time that flight 1420 touched down, but this information was not available to the flight crew or the controller because the system's 2-minute wind data are not directly reported to the control tower. The controller's final wind report to the flight crew (320° at 23 knots, which was transmitted 27 seconds before touchdown) would not have indicated the possibility of a tailwind component at touchdown. Although the 5-knot tailwind component was within the 10-knot limitation required by American's flight manual and advised by Boeing in its MD-80 Flight Crew Operating Manual (FCOM), the Safety Board notes that the flight crew's purpose in changing runways from 22L to 4R was to avoid a tailwind component. The 20- to 25-knot crosswind component, however, exceeded the 10-knot limitation required by American's flight manual for a runway with an RVR of less than 1,800 feet.

Flight 1420 departed the end of runway 4R sliding to the left, with its nose gear on the left edge of the runway and the main gear off the left edge of the runway, at a calculated speed of 97 knots. The airplane sustained no damage before its departure from

¹⁹² The Safety Board notes that, during flight 1420's final approach segment, the microburst was located northwest of the airport and that the missed approach procedure would have taken the airplane east of the airport.

the runway. The airplane likely collided with the runway 22L approach lighting system support structure at a calculated speed of about 83 knots.

With the use of Boeing's MD-80 Operational Landing Program, the Safety Board predicted that the accident airplane experienced a wet runway braking coefficient of at least 0.23 at 140 knots and 0.25 at 160 knots. Typical braking coefficients to indicate dynamic hydroplaning range from 0.02 to 0.04. Thus, flight 1420 experienced a maximum braking coefficient that was over six times greater than the maximum typical hydroplaning braking coefficient.

Examination of the accident airplane's hydraulic brake system and the lack of hydraulic fluid contamination on the runway indicated that the hydraulic brake system was most likely capable of functioning within operational parameters. Examination and testing of the airplane's antiskid system and the lack of flat spots or reverted rubber on any main landing gear tire indicated that the antiskid system was most likely capable of functioning within operational parameters.

The Safety Board's examination of runway 4R determined that it was in good condition with normal or better-than-normal surface conditions for friction levels and counter-hydroplaning effectiveness. A senior research engineer from NASA's Langley Research Center stated at the public hearing that runway 4R's grooving was satisfactory but that its microtexture was above average and macrotexture was excellent. More importantly, the engineer stated that the runway's ability to prevent hydroplaning and other braking problems was excellent. The Safety Board concludes that dynamic or reverted rubber hydroplaning did not occur during the accident airplane's landing rollout.

Flight 1420's substantial drift angle while on the runway (as much as 16° both to the right and the left of the direction of travel) was evidence of a directional control problem. The Safety Board examined the lack of spoiler deployment upon touchdown, the use of reverse thrust greater than 1.3 engine pressure ratio (EPR), and the use of manual rather than automatic brakes and evaluated the role that each played in the flight crew's inability to maintain directional control of the airplane on the runway and stop the airplane within the remaining available runway length (5,200 feet).

2.2.2.1 Lack of Spoiler Deployment

The spoiler system aboard the accident airplane was reported to be operating properly by the previous flight crew. FDR data from the airplane's previous landing showed that the left outboard and right inboard flight spoilers (the only two spoiler parameters recorded) deployed upon touchdown and remained fully deflected for about 33 seconds. Also, FDR data from the accident flight indicated that the flight spoilers extended symmetrically (in response to a pilot input using the spoiler handle) for about 55 seconds during the descent into Little Rock.

After the accident, the ground and flight spoilers were found in the retracted position. FDR data showed that, other than a momentary deflection by the left outboard flight spoiler concurrent with a left aileron deflection, the spoilers did not deploy upon

touchdown. FDR data also showed a momentary full deflection of the right inboard flight spoiler concurrent with a full right aileron roll input during the landing rollout. The spoiler movement recorded on the FDR indicated that the spoiler position sensors and the spoiler control and hydraulic systems were working properly before and during the landing rollout.

2.2.2.1.1 Autospoiler Arming

As stated in section 2.2.1.3, autospoiler arming was one of the 10 items on the Before Landing mechanical checklist. According to American's DC-9 Operating Manual procedures that were in effect at the time of the accident, the nonflying pilot was responsible for ensuring that each checklist item had been accomplished. For autospoiler arming, the nonflying pilot was to state "spoiler lever," announce that the spoilers had been armed, and move the spoiler lever switch on the mechanical checklist. American's DC-9 Operating Manual procedures, however, did not specify which pilot was responsible for physically arming the spoilers. The company's June 25, 2001, party submission indicated that, for flight 1420, the first officer (the nonflying pilot) was responsible for arming the spoilers.

According to postaccident interviews with company line pilots, instructors, and check airmen, American's MD-80 pilots were instructed during simulator training that the nonflying pilot was to arm the spoilers. In contrast, the line pilots indicated that it was accepted practice for captains to arm the spoilers, regardless of whether they were the flying or nonflying pilot, because the spoiler handle is located on the forward left, or captain's, side of the center pedestal.¹⁹³ The Safety Board notes that, on February 23, 2000, American revised its procedures to state that the captain is always responsible for arming the spoilers.

As the chief pilot at American's Chicago base of operations, the captain was required to fly less frequently than line pilots. However, the captain had become a chief pilot only months before the accident and had flown 54 hours in the 90 days before the accident flight. Thus, it is likely that he was aware of the common practice during line operations for the captain, rather than the nonflying pilot, to arm the spoilers. However, as a check airman, the captain would have likely been ensuring during check rides that the nonflying pilot was arming the spoilers.

The first officer for flight 1420 stated, in a postaccident interview, that he did not arm the spoilers because he thought that the captain had armed them. The first officer indicated that he had moved the switch on the mechanical checklist to indicate that the spoilers had been armed. However, the CVR did not indicate any mention of the first

¹⁹³ To arm the spoilers on the MD-80 series airplane, the handle must be grasped and squeezed while it is lifted up toward its full travel limit. The pilot in the left seat of the airplane can reach the handle without obstruction, but the pilot in the right seat of the airplane must reach in front of, or behind, the throttle levers (and possibly around the captain's arm if his or her hand were on the throttle at the time) to manipulate the spoiler handle. A search of NASA's Aviation Safety and Reporting System database using the terms "spoiler handle" and "spoiler arming" did not reveal any reports consistent with flight crews having difficulty arming the spoiler handle.

officer's required "spoiler lever" callout or any verbal verification that the spoilers were armed.¹⁹⁴ In addition, there were no sounds or other indications on the CVR that were consistent with the spoiler handle being armed.

During postaccident examination, the spoiler handle appeared to be in the full aft position with the red ARM indicator stripe partially visible; however, the cockpit center pedestal showed deformation and displacement in the left downward direction as a result of the damage to the cockpit floor structure during the impact sequence. Teardown of the center pedestal revealed no significant marks on the spoiler handle or handle slot to indicate the handle's position at impact. In addition, the teardown revealed that the autospoiler crank arm was found in its fully extended position and was positioned above the spoiler handle's roller—the contact point against which the crank arm pushes to extend the handle during normal autospoiler extension.

Teardown of the autospoiler actuator revealed that the actuator was in the fully extended (deployed) position, which was consistent with proper autospoiler operation with the autospoiler handle in the unarmed position. Thus, the spoiler handle was actually in the stowed position at impact but appeared to be in the fully extended position only because of impact damage. Further, testing of the primary components of the autospoiler system—the autospoiler actuator, the autospoiler switching unit, the ground spoiler control box, and the two ground nose oleo switches—revealed that all were capable of functioning properly.

The CVR transcript identified the sound of two "thuds" similar to the sound of an airplane touching down on a runway along with a "squeak" sound at 2350:20.2, 2 seconds before the first officer stated, "we're down." Analysis of the CVR sound spectrum for the accident airplane indicated that the first "thud" was main landing gear touchdown and that the second "thud" was nose gear touchdown. Safety Board investigators determined that the squeak sound, which occurred in between the two "thud" sounds, was the autospoiler actuator operating. Because of the placement of the squeak sound, Board investigators further determined that the actuator was triggered at main landing gear touchdown by the wheel spin-up transducers.

The Safety Board compared the CVR sound spectrum for the accident airplane with those for other CVR recordings obtained during the Palm Springs incident and the flight and ground tests that were conducted as part of the investigations of this accident

¹⁹⁴ There are straightforward visual cues to indicate the position of the spoiler handle to the flight crew (see section 1.6.2), and a visual assessment of the handle's status can be made from either seat in the MD-80 cockpit. The pilot in the left seat has an unobstructed view of the entire length of the spoiler handle. As a result, no change in head or body position is required to visually assess the status of the handle. However, the pilot in the right seat of the airplane normally has a partially obstructed view of the spoiler handle. Obstructions in the normal field of view include the throttle handles, the thrust reverser levers, and the right hand of the pilot in the left seat. If the pilot in the right seat were to adjust his or her head position, an unobstructed view of the handle could be achieved to assess the status of the spoiler handle. A search of the Aviation Safety and Reporting System database using the terms "spoiler handle" and "spoiler arming" did not reveal any reports consistent with flight crew difficulty confirming the spoiler handle's status on MD-80 series airplanes.

and the Palm Springs incident.¹⁹⁵ According to the CVR sound spectrum study, the sound durations associated with the autospoiler actuator extension for the Little Rock and Palm Springs flights (0.08 and 0.06 second, respectively) were consistent with the ground test in which the spoiler handle was unarmed (0.06 second). The study also indicated that, for the two flight tests and two ground tests involving normal autospoiler operation (that is, when the spoiler handle was armed before touchdown and the spoilers fully deployed after touchdown), the sounds associated with the activation of the autospoiler actuator lasted at least two times longer for the flight and ground test airplane recordings (between 0.16 and 0.19 second) than the sounds for the Little Rock airplane recording.

The ground tests conducted on the Palm Springs airplane also indicated that, when the left throttle was at least 1 3/8 inches above idle and the autospoiler actuator operated, the spoiler handle would fully extend (by means of the autospoiler actuator), be knocked down, and retract about 0.5 second later to the stowed position. Because the two spoiler positions—the left outboard and right inboard—are recorded alternately every 0.5 second with about 0.25 second in between recordings, it is likely that an autoretract event would be captured by an FDR. In fact, the ground test FDR captured all of the autoretract events, and the two spoiler autoretract events reported by American (see section 1.6.2.2) were captured on FDR data. However, no indication of an autoretract event was found on the flight 1420 FDR data.

The CVR sound spectrum study, physical evidence, and testing and teardown results indicate that the autospoiler actuator on the flight 1420 airplane operated properly at touchdown and that the spoiler handle was in the unarmed position when the autospoiler actuator extended. Accordingly, the Safety Board concludes that the autospoiler system operated properly and that the spoilers did not automatically deploy because the spoiler handle was not armed by either pilot before landing.

2.2.2.1.2 Checklist Design Regarding Spoiler Arming

At the time of the accident, American did not require spoiler arming to be a dual crewmember challenge and response checklist item. Dual callouts protect against the failure that one pilot would identify an item as complete before it has been accomplished or omitting an item entirely during a high workload phase of flight.¹⁹⁶

The human factors principles of checklist design established by the FAA and incorporated in its publications are available to airlines and FAA inspectors. These principles prescribe that checklist items affecting safety of flight should ensure that the proper levels of operational redundancy have been achieved. For example, many checklists require both flight crewmembers to positively confirm the status of flap settings

¹⁹⁵ As discussed in section 1.16, the Little Rock accident and the February 16, 2000, Palm Springs incident were similar in that they both involved American Airlines MD-80 series airplanes that did not experience autospoiler extension at touchdown.

¹⁹⁶ See U.S. Department of Transportation, Federal Aviation Administration. 1995. *Human Performance Considerations in the Use and Design of Aircraft Checklists*. Also see Degani, A., and Wiener, E.L. 1990. *Human Factors of Flight-Deck Checklists: The Normal Checklist*. National Aeronautics and Space Administration Contractor Report 177549.

before takeoff and gear position before touchdown. The Safety Board recognizes that MD-80 series airplanes can be dispatched with the autospoiler system inoperative; thus, the system is not considered to be an item that is critical to safety of flight. However, spoiler deployment after touchdown is crucial to optimal landing performance, and the autospoiler system, if installed and operative, is the most reliable and efficient way to engage the flight and ground spoilers during landing.

The Safety Board notes that, on June 22, 2000, American revised its Before Landing checklist procedures, requiring both the flying and nonflying pilots to verify and respond that the spoilers have been armed. The Board acknowledges that American's procedures now require dual crewmember confirmation of the spoiler arming checklist item but is concerned that other airplane operators may not include this requirement in their operating procedures. The Safety Board concludes that a high level of operational redundancy should exist to ensure that spoiler arming has been completed before landing. Therefore, the Safety Board believes that the FAA should require, for all 14 CFR Part 121 and 135 operators of airplanes equipped with automatic spoiler systems, dual crewmember confirmation before landing that the spoilers have been armed and that the FAA should verify that these operators include this procedure in their flight manuals, checklists, and training programs.

2.2.2.1.3 Manual Spoiler Deployment

At the time of the accident, American's DC-9 Operating Manual required both pilots to monitor the automatic deployment of the spoilers after touchdown. Pilots can verify that the spoilers have automatically deployed by the extensive movement of the handle to the extend position and the distinct "clanking" sound associated with the handle's travel. No written procedure in any of American's manuals required either pilot to announce the failure of the spoilers to automatically deploy. However, American's DC-9 Operating Manual indicated that, if the spoilers failed to deploy automatically, the captain was responsible for manually extending them regardless of which pilot was making the landing.

Even though American's manuals did not require pilots to announce if the spoilers failed to automatically extend, the MD-80 Fleet Manager and several MD-80 check airmen stated, during postaccident interviews, that pilots were trained to make this announcement. (The adequacy of American's spoiler system training at the time of the accident is discussed in section 2.6.2.) However, the CVR did not record any announcement by either pilot that the spoilers had failed to deploy automatically or any sounds that could be associated with an attempt to manually extend the spoilers.

The Safety Board concludes that the flight crew failed to verify that the spoilers had automatically deployed after landing and that the captain failed to manually extend the spoilers when they did not deploy. As a result, the wings continued to support most of the airplane's weight, and very little weight was transferred to the landing gear, preventing the main landing gear tires from developing the braking and cornering forces required to achieve expected deceleration and directional control performance.

In the Little Rock accident, the pilots' workload associated with attempting to maintain directional control of the airplane on the runway may have prevented them from detecting that the spoilers had not automatically deployed. The flight crew's failure to detect that the spoilers had not deployed might have been avoided if a procedural requirement similar to the one in Boeing's MD-80 FCOM had been in place at the time. According to the Boeing manual, the nonflying pilot should call out "no spoilers" if the spoiler lever does not move aft after touchdown, and the flying pilot should then move the lever aft to the full extend position and up to the latched position. American's February 23, 2000, revision to its DC-9 Operating Manual incorporated a similar requirement. The Safety Board acknowledges American's revision but is disappointed that this change and those related to spoiler arming (that is, the captain will always arm the spoilers and both crewmembers will confirm that the spoilers have been armed) were not put into effect until after the Palm Springs incident, which occurred more than 8 months after the Little Rock accident.

The Safety Board is concerned that other air carriers may not require callouts regarding the status of the spoilers after touchdown. The Safety Board concludes that, because spoiler deployment is critical for optimal landing performance, procedures to ensure that the spoilers have deployed after touchdown should be a required part of all air carriers' landing operations. Therefore, the Safety Board believes that the FAA should require, for all 14 CFR Part 121 and 135 operators, a callout if the spoilers do not automatically or manually deploy during landing and a callout when the spoilers have deployed and that the FAA should verify that these operators include these procedures in their flight manuals, checklists, and training programs. The procedures should clearly identify which pilot is responsible for making these callouts and which pilot is responsible for deploying the spoilers if they do not automatically or manually deploy.

The Safety Board's Airplane Performance Study demonstrated that spoiler deployment is critical to an airplane's braking force. For example, when the spoilers on an MD-80 series airplane weighing 127,000 pounds and traveling at 140 knots are extended, about 65 percent of the airplane's weight is supported by the main landing gear; when the spoilers are not extended, only about 15 percent of the airplane's weight is supported by the main landing gear.¹⁹⁷ In this accident, the light loading of the landing gear substantially reduced the effectiveness of the brakes and the ability of the gear to develop cornering

¹⁹⁷ These findings were consistent with information presented by the Boeing aerodynamics engineer at the public hearing for this accident regarding the spoilers' effect on the weight applied to the wheels immediately after touchdown for an MD-80 series airplane with a similar landing weight as the accident airplane.

loads to counter the aerodynamic side loads produced by the crosswind.¹⁹⁸ The Safety Board concludes that the lack of spoiler deployment led directly to the flight crew's problems in stopping the airplane within the remaining available runway length and maintaining directional control of the airplane on the runway. Regarding the inability to stop an airplane within an available runway length, the lack of spoiler deployment is far more critical than the use of reverse thrust (discussed in section 2.2.2.2).

2.2.2.2 Use of Reverse Thrust Above 1.3 Engine Pressure Ratio

American's DC-9 Operating Manual indicated that, for landings on slippery runways, pilots were not to exceed 1.3 EPR on the "slippery portions of the runway" except in an emergency situation. Likewise, Boeing's MD-80 FCOM indicated that reverse thrust of no more than 1.3 EPR should be used on wet or contaminated runways, except in an emergency. However, FDR evidence indicated that reverse thrust exceeded 1.3 EPR several times during flight 1420's landing sequence.¹⁹⁹ Further, American's and Boeing's maximum reverse thrust setting for landings on dry runways was 1.6 EPR, and FDR data showed that even this setting was exceeded many times during the landing.

The CVR recorded the first officer's statement "we're sliding" about 4 seconds after the airplane touched down on the runway. FDR data indicated that, about 1 1/2 seconds after this statement, 1.89 and 1.67 reverse EPR were being applied to the left and right engines, respectively. FDR data indicated that the thrust reversers were returned to the unlocked status as the airplane was continuing to slide.²⁰⁰ However, the thrust reversers were deployed again; the left engine reached a maximum setting of 1.98 reverse EPR, and the right engine reached a setting of 1.64 reverse EPR. The reversers were returned again to the unlocked status; as the right thrust reverser was moving to the unlocked status, the right engine reached a maximum setting of 1.74 reverse EPR. By this point, the captain was likely applying excessive reverse thrust because he perceived that the landing had become an emergency situation.

¹⁹⁸ The effects of the light loading on the main landing gear may have been exacerbated by the position of the elevator surfaces during the landing roll. McDonnell Douglas' 1996 all operators letter indicated that, when operating on wet or slippery runways, pilots should not apply an excessive amount of down elevator because it will unload the main gear and reduce braking efficiency. However, the left and right elevator surfaces were deflected full nose down between 2,800 and 5,000 feet beyond the runway 4R threshold.

¹⁹⁹ The thrust reverser deployment recorded on the FDR when the airplane powered back from the gate during its departure from Dallas/Fort Worth to Little Rock indicated that the thrust reverser position sensors were working properly.

²⁰⁰ American's DC-9 Operating Manual stated that, if an airplane begins to drift across the runway while reversing, pilots should immediately come out of reverse thrust to help regain directional control and restore rudder effectiveness.

On the MD-80 series airplane, excessive reverse thrust can reduce or eliminate rudder and vertical stabilizer effectiveness.²⁰¹ In fact, FDR data for the flight 1420 airplane were consistent with deteriorated rudder and vertical stabilizer performance because of the use of excessive reverse thrust.²⁰² Specifically, at the time that the heading of the airplane was moving nose left from 1° to 3° per second despite substantial nose right rudder inputs, the thrust reversers were deployed. The left engine EPR reached values of 1.3 or greater almost continuously; the right engine EPR reached values of 1.3 or greater several times. The heading stopped moving left, and rudder effectiveness was restored, when the thrust reversers were briefly stowed.

When reverse thrust was applied again, the airplane started to yaw left once more (the heading was moving left about 1.5° per second) despite full right rudder inputs. The airplane then reacted dramatically to the rudder inputs when the thrust reversers were stowed for the second time; the yaw rate reversed, and the heading started to move right up to 7° per second. The airplane was continuing to yaw to the right (the heading was increasing 4° per second) when it departed the left side of the runway; at that time, the left engine thrust reverser was deployed, but the engine's EPR was at an idle power level. The Safety Board concludes that the use of reverse thrust at levels greater than 1.3 EPR significantly reduced the effectiveness of the airplane's rudder and vertical stabilizer and resulted in further directional control problems on the runway.

Postaccident observations of American's MD-80 simulator training sessions revealed that the training focused on applying 1.6 EPR reverse thrust when landing. There was no discussion of the company's procedures to limit reverse thrust to 1.3 EPR when landing on slippery runways, and pilots were observed exceeding 1.3 EPR when slippery runway conditions were presented. In fact, one of the simulator instructors initially taught that 1.6 EPR was acceptable for landing on a slippery runway unless a crosswind was present (see section 1.17.2.2). On February 23, 2000, American revised its DC-9 Operating Manual, indicating that, for all MD-80 landings, reverse thrust should not exceed 1.3 EPR unless stopping distance is in doubt.

The Safety Board concludes that the maximum reverse thrust for MD-80 landings on wet or slippery runways should be 1.3 EPR, except when directional control can be sacrificed for a marginal increase in deceleration. Therefore, the Safety Board believes that the FAA should issue a flight standards information bulletin that requires the use of 1.3 EPR as the maximum reverse thrust power for MD-80 series airplanes under wet or slippery runway conditions, except in an emergency in which directional control can be

²⁰¹American's DC-9 Operating Manual stated that the rudder is almost "completely ineffective" at 1.6 EPR and a speed of 90 knots. McDonnell Douglas, in its 1996 all operators letter, warned that, as reverse thrust increases above approximately 1.3 EPR, rudder effectiveness continues to decrease and that, at a reverse thrust greater than approximately 1.6 EPR, the rudder provides little or no directional control. During the time that the accident airplane's reverse thrust settings were 1.6 EPR and greater, the airplane was traveling down the runway at speeds greater than 90 to 100 knots.

²⁰² Loss of directional control associated with high reverse thrust EPRs has been observed in other accidents involving DC-9 airplanes landing on wet or contaminated runways, including the March 5, 1997, American Airlines flight 320 accident in Cleveland, Ohio. The description for this accident, IAD97FA052, can be found on the Safety Board's Web site at <<http://www.nts.gov>>.

sacrificed for decreased stopping distance. The Safety Board also believes that the FAA should require principal operations inspectors (POI) of all operators of MD-80 series airplanes to review and determine that these operators' flight manuals and training programs contain information on the decrease in rudder effectiveness when reverse thrust power in excess of 1.3 EPR is applied. The Safety Board further believes that the FAA should require all operators of MD-80 series airplanes to require a callout if reverse thrust power exceeds the operators' specific EPR settings.

2.2.2.3 Use of Manual Braking

The preflight weather package (which contained weather information issued about 2205) indicated that the runways at Little Rock airport were wet with no measurable rain and no braking action reports. According to the CVR, the captain had decided, at 2331:24 (before establishing contact with the Little Rock tower), to use manual brakes. At that point in the approach, the flightpath was still free of convective activity. However, the CVR did not record any discussion between the pilots regarding whether the use of manual brakes for the landing was still prudent in light of the changing weather conditions on approach to the airport.

The flight crewmembers had received a report from the controller that heavy rain was falling at the airport, so they should have been concerned that the runway would be slippery. The crewmembers had also received a report from the controller about a strong crosswind, so they should have been aware that significant rudder inputs could be required to maintain directional control of the airplane on the runway and that these inputs could take away from their ability to maximize manual braking. In addition, the flight crew recognized that runway 4R was considered a short runway for a DC-9 landing,²⁰³ so maximum efficiency of the brakes was critical. These conditions justified the use of autobrakes for the landing on runway 4R. In fact, Boeing's procedures indicated that maximum autobrakes should be used for landing on a wet or slippery runway.²⁰⁴

According to FDR data, the initial application of manual brakes began about 5 seconds after touchdown, and full application of the manual brakes was not recorded until about 11 seconds after touchdown.²⁰⁵ These time intervals are not indicative of aggressive manual braking.

The use of autobrakes requires either automatic or manual spoiler deployment at touchdown, which did not occur in this situation; therefore, autobrakes would not have helped decelerate the accident airplane. However, if the spoilers had deployed and the

²⁰³ In a postaccident interview, the first officer stated that the captain briefed 40° flaps for the landing because of the short runway.

²⁰⁴ As stated in section 1.17.4.3, American's DC-9 Operating Manual stated that maximum autobrakes could be used on short or slippery runways but did not specify the type of braking that should be used on wet runways or during crosswind conditions.

²⁰⁵ As stated in section 1.17.4.3, American's DC-9 Operating Manual stated that aggressive manual braking could be used on short or slippery runways. The manual further stated that, for manual brake stopping on short or slippery runways, the full brake pedal should be used immediately after nose gear touchdown.

flight crew had selected maximum autobrakes for the landing, initial brake application could have occurred about 4 seconds sooner.

On June 27, 2000, American issued a revision to its DC-9 Operating Manual, requiring the use of autobrakes for four specific circumstances: when a runway is less than 7,000 feet long; an RVR is less than 4,000 feet or visibility is less than 3/4 mile; a runway is contaminated with standing water, snow, slush, or ice; or braking conditions are reported to be "less than good." Also, the revision recommended, but did not require, the use of autobrakes when landing with gusty winds or crosswinds. The Safety Board acknowledges that American has implemented specific criteria requiring the use of autobrakes but is concerned that the company still does not require autobrakes during landings with crosswinds.

In the aviation industry, it is generally understood that landing during high crosswinds (that is, in excess of 10 knots) requires the pilot to make significant rudder pedal inputs to maintain directional control of the airplane. Because manual braking is accomplished by applying pressure to the upper portion of the rudder pedals, the Safety Board is concerned that a pilot who uses manual brakes during high crosswind conditions might not be able to immediately apply and maintain aggressive manual braking. In this accident, the captain likely did not apply full manual braking for 11 seconds because he was making significant rudder pedal inputs to keep the airplane on the runway. In fact, the first officer stated that he had to help the captain with his braking efforts as the airplane was nearing the end of the runway.

FDR data showed that the left brake pedal was relaxed momentarily after full braking was achieved. However, this brake relaxation occurred while the airplane was drifting to the right (that is, its nose was pointed to the left of the direction of travel) and coincided with the application of full right rudder. Thus, the brake pedal relaxation may have been the result of the captain's attempt to apply differential brakes to correct the airplane's heading or his inability to maintain full braking while applying full right rudder.

The use of automatic brakes is also important for airplanes landing on wet or slippery runways. Brakes decrease stopping distance most effectively when they are applied at a high speed. Any delay in brake application after touchdown results in a considerable increase in the required stopping distance because the highest speed during the ground roll (the most distance traveled per unit of time) occurs immediately after touchdown. An interruption in brake application at lower speeds is less critical because the airplane does not travel as far (that is, it does not consume as much runway) in the same time at low speed as it does at high speed. Because wet or slippery runway conditions degrade an airplane's landing performance, fast brake application in these circumstances is critical.

The Safety Board recognizes that airplane operators may not choose to require automatic braking because that type of braking, compared with manual braking, will wear out brakes faster and thus require brake replacement more often. The Board also recognizes that, during optimal landing situations, pilots can apply manual brakes more quickly than automatic brakes.²⁰⁶ However, during high workload landing situations that

may require active or aggressive use of the rudder pedals, the use of automatic brakes provides pilots with a faster, more consistent means for stopping an airplane within the available runway length. The Safety Board concludes that automatic brake systems reduce pilot workload during landings in wet, slippery, or high crosswind conditions. Therefore, the Safety Board believes that the FAA should require, for all 14 CFR Part 121 and 135 operators, the use of automatic brakes, if available and operative, for landings during wet, slippery, or high crosswind conditions and that the FAA should verify that these operators include this procedure in their flight manuals, checklists, and training programs.

2.2.2.4 Summary of the Landing

The airplane's performance during the landing roll indicates that flight 1420 experienced many of the difficulties discussed in McDonnell Douglas' February 1996 MD-80 all operators letter regarding landing operations on wet or slippery runways: greatly reduced reaction forces on the gear (because of the spoiler position), unloading of the main gear because of large nose-down elevator inputs, strong crosswinds, loss of vertical stabilizer and rudder effectiveness because of reverse thrust greater than 1.3 EPR, and a slight tailwind (see section 1.17.4.4.2). In addition, the airplane touched down about 2,000 feet down the 7,200-foot runway going 29 knots faster than the zero-wind touchdown ground speed that would result from an approach at the reference airspeed. The resulting ground trajectory of the airplane is consistent with the expected airplane performance, as determined from Boeing's Operational Landing Program, and the operational experience outlined in the all operators letter.

The Safety Board's Airplane Performance Study indicated that the accident airplane could have stopped about 700 feet before the end of the runway if the spoilers had deployed, a constant symmetrical reverse thrust at 1.3 EPR had been maintained, and the flight 1420 manual braking profile had been applied. In contrast, with the spoilers not extended, the airplane could not have stopped within the remaining runway length even if maximum manual braking had been applied immediately after touchdown and symmetrical reverse thrust at 1.3 EPR had been maintained throughout the landing roll. Thus, the Safety Board concludes that the lack of spoiler deployment was the single most important factor in the flight crew's inability to stop the accident airplane within the available runway length.

2.2.3 Human Factors

During the accident flight, both crewmembers made basic errors in flight management and the completion of routine tasks, including required callouts.²⁰⁷ In addition, the flight crew did not appear to be effectively evaluating the weather cues that

²⁰⁶ Boeing's MD-80 FAA-approved Airplane Flight Manual, Appendix 5, "Automatic Brake System," states that, because of the delay in automatic brake application and the conservative testing conditions that were used to construct the automatic brake landing distance data, stopping performance in the MAX setting does not achieve the same level of performance compared with manual braking. In addition, the manual states, "stopping distances are provided for guidance information only to assist in the selection of the most desirable setting."

were available or considering their cumulative effect, specifically, that the thunderstorm had likely already arrived at the airport. The Safety Board recognizes that the flight crew was provided with only general, advisory information on severe weather avoidance rather than specific operational decision-making criteria regarding the penetration of convective activity (see section 2.3.1.1). However, the Safety Board concludes that the flight crewmembers' performance during the accident flight was degraded, as evidenced by their operational errors and impaired decision-making.

The flight crew's degraded performance was inconsistent with the level of performance that would have been expected from both pilots, considering that the captain was a chief pilot and check airman and that the first officer, as a new hire, had been recently trained in American's standards and procedures. Also, the flight crew's performance deviated significantly from the positive statements that other pilots made about both pilots' skills, abilities, and cockpit style. The captain was described in postaccident interviews as a conservative pilot who used common sense, demonstrated wisdom and experience, and was professional. The first officer was described in postaccident interviews as an above-average new hire who was very competent and knowledgeable and an experienced pilot with good cockpit discipline, and his probationary file contained favorable comments about his performance. In addition, the captain was appointed to the chief pilot position because he possessed good technical skills and leadership abilities. Factors that contributed to the flight crew's degraded performance—situational stress and fatigue—are discussed in section 2.2.3.1 and 2.2.3.2, respectively.

The pairing of the first officer, a new hire who was 5 months into his probationary year, with the captain, a chief pilot and check airman with over 10,000 flight hours (more than half of which were as an MD-80 captain), was evaluated and determined not to be a factor in the accident. Although it is possible that a probationary first officer might find speaking and challenging a captain who is a chief pilot to be difficult, CVR evidence indicated that this first officer was assertive during most of the flight for which CVR information was available. For example, the first officer initiated an abbreviated approach briefing after the change in runways and queried the captain when he failed to command the final landing flap configuration. Further, the first officer was instrumental in directing the captain to the airport during the attempted visual approach.

²⁰⁷In addition to the callout errors discussed in section 2.2.1.3, the captain did not call out "Track—Track" when he had the initial movement of the localizer needle on his horizontal situation indicator, nor did he call out "Outer Marker" and the msl crossing altitude as the airplane crossed the outer marker beacon on the ILS approach course. Finally, he did not call out "Landing" before descending below the decision altitude, which would have confirmed that he had adequate visual reference with the runway. The first officer did not challenge the captain on these required Category I ILS callouts. Also, neither pilot made the required "radio altimeter alive" callout, and the first officer did not call out, as required, "decision altitude," speed deviations of ± 5 knots, and rates of descent exceeding 1,000 feet per minute.

2.2.3.1 The Role of Situational Stress

The presence of weather as a potential threat to the safety of flight and efforts to expedite the landing were stresses to the flight crew. Research has demonstrated that decision-making can be degraded when individuals are under stress because they selectively focus on only a subset of cues in the environment. As a result, any situation assessment may be incomplete, and the resulting decision, even when made by an expert, may be degraded. Stress can also impede an individual's ability to evaluate an alternative course of action, resulting in a tendency to proceed with an original plan even though it may no longer be optimal. Research on decision-making has demonstrated a natural tendency for individuals to maintain their originally selected course of action until there is clear and overwhelming evidence that the course of action should be changed (see section 1.18.3.2).

The CVR contained no evidence to indicate that the flight crew had reevaluated its original plan to expedite the landing because of the approaching weather. The actions taken by the flight crewmembers throughout the approach were consistent with their original plan. Despite several cues that indicated that the weather at the airport had deteriorated, neither crewmember discussed a need to initiate a go-around, enter a holding pattern, or divert to an alternate airport. The Safety Board also notes that any delay in landing would have further extended the pilots' duty day, but there is no evidence to indicate that this factor affected the flight crew's decision to continue the approach.

The flight crewmembers' intention to expedite the landing despite the weather diverted their attention away from other activities during the final minutes of the flight and, as a result, affected the crew's ability to properly assess the situation and make effective decisions. Therefore, the Safety Board concludes that the flight crewmembers' focus on expediting the landing because of the impending weather contributed to their degraded performance.

2.2.3.1.1 Industry Standards and Practices

The Safety Board evaluated the flight crew's decision to conduct an approach to an airport environment surrounded by severe convective activity in relation to contemporary industry standards and practices. Most airlines and flight training programs instruct pilots to avoid thunderstorms during routine operations. However, data from accidents and incidents demonstrate that pilots penetrate thunderstorms—in some cases with catastrophic results, as shown by the USAir flight 1016 and the Delta flight 191 accidents. In fact, in its final report on the Delta flight 191 accident, the Safety Board stated that "there is an apparent lack of appreciation on the part of some, and perhaps many, flight crews of the need to avoid thunderstorms and to appraise the position and severity of the storms pessimistically and cautiously."

A June 1999 report sponsored by NASA and conducted by research staff at the Massachusetts Institute of Technology's Lincoln Laboratory (see section 1.18.2) used weather radar and ATC radar data sources to document flight crew behavior during 60 hours of observations in the Dallas/Fort Worth terminal area during convective activity.

This research documented that pilots routinely penetrated thunderstorms with NWS precipitation intensity levels of 3 (strong), 4 (very strong), and 5 (extreme) rather than deviated around them, especially when approaching an airport to land. Of the 1,952 encounters with thunderstorm cells recorded in these data, pilots penetrated the thunderstorms 1,310 times (67 percent). However, the study did not include information from the pilots regarding the reasons for the actions documented by the flight data. The study concluded that pilots were more likely to penetrate a thunderstorm when they were flying after dark, flying within 10 to 16 miles of the airport, following another aircraft, or running behind schedule by more than 15 minutes. All but one of these factors (following another aircraft) applied to the accident flight.

In its final report on the Delta flight 191 accident, the Safety Board stated its concern that “the present training within the industry for windshear encounters on the final approach seems to advocate the philosophy that the retrieval of the approach profile is the desired end result and not escape from the environment.” The results of the NASA study, which was completed 13 years after the Delta flight 191 accident report was issued, demonstrate that this industry philosophy can also apply to the penetration of severe thunderstorms.

Some air carriers, including American, provide their flight crews with only general, advisory information on severe weather avoidance. As a result, the individual flight crews are responsible for making decisions on whether an approach near convective activity should continue, and such decisions are typically based on the pilots’ subjective assessment of the severity of the situation and their experience. The Safety Board is aware that some other air carriers provide their pilots with specific operational guidance, including decision aids and flow charts in quick reference checklists, from which flight crews can make “go” or “no go” decisions concerning operations near hazardous weather. Such information includes a detailed list of specific cues and operational criteria from which pilots can easily assess weather conditions and objectively determine whether they can safely continue or need to take a different course of action. As a result, the pilots do not have to rely on an open-ended decision-making process regarding whether and at what point to deviate around weather. Further, these explicit, formalized cue recognition and decision aids minimize the potential for thunderstorm penetrations resulting from impaired judgment and decision-making because of situational stress or fatigue.

In addition, as demonstrated in this accident, airborne weather radar does not always facilitate a flight crew’s assessment of a thunderstorm regarding the storm’s location and movement relative to the airport and its severity, including the potential for microburst conditions. The Safety Board is aware that recent technologies, such as moving airport map displays integrated with airborne weather radar displays and real-time wind readouts, are available in new-generation airplanes with “glass cockpits.”²⁰⁸ Also, NASA, the FAA, and avionics manufacturers are testing whether ground-based advanced weather graphics, such as regional radar mosaics and single Doppler radar images, can be

²⁰⁸ The term “glass cockpit” refers to cockpits with cathode ray tubes or flat plate screens that integrate multiple sources of flight information formerly displayed on analog dials and gyro instruments. An example of a glass cockpit system is the Enhanced Flight Information System.

up-linked to airplanes. These graphics can show enhanced detail of a thunderstorm (including its intensity, movement, and tops) and other weather information; therefore, they have the potential for providing flight crews with in-flight information to improve their situational awareness and decision-making regarding hazardous weather.

Because the NASA study showed no discernible differences among operators and airplane types regarding the propensity to penetrate thunderstorms, the Safety Board concludes that aircraft penetration of thunderstorms occurs industry-wide. Therefore, the Safety Board believes that the FAA should establish a joint Government-industry working group to address, understand, and develop effective operational strategies and guidance to reduce thunderstorm penetrations and should verify that these strategies and guidance materials are incorporated into air carrier flight manuals and training programs as the strategies become available. The working group should focus its efforts on all facets of the airspace system, including ground- and cockpit-based solutions. The near-term goal of the working group should be to establish clear and objective criteria to facilitate recognition of cues associated with severe convective activity and guidance to improve flight crew decision-making.

2.2.3.2 The Role of Fatigue

The CVR contained no statements to indicate that either pilot was tired, but the CVR did record a yawn at 2324:13 from one of the pilots. The first officer stated, after the accident, that it had been a long day and that he was getting tired but that he felt fine when flying to Little Rock. In addition, the first officer stated that he did not remember talking with the captain about whether he was tired, but the first officer was not concerned about the captain being fatigued. However, research indicates that self-assessment of fatigue impairment and detection of fatigue in others are inaccurate. Thus, the Safety Board examined whether cumulative sleep loss, continuous hours of wakefulness, and the time of the accident relative to the flight crew's normal schedule were consistent with the development of fatigue.²⁰⁹

First, the captain and the first officer reportedly received a normal amount of sleep the night before the accident; both went to sleep about 2200 and awoke about 0730. Also, there was no evidence that either pilot had experienced cumulative sleep loss in the days before the accident.

Second, at the time of the accident (2350:44), the captain and the first officer had been continuously awake for at least 16 hours.²¹⁰ Research indicates that the normal

²⁰⁹ In its final report on the American International Airways flight 808 accident in Guantanamo Bay, Cuba, the Safety Board explained that these three background factors are commonly examined for evidence related to fatigue. For more information, see National Transportation Safety Board. 1994. *Uncontrolled Collision With Terrain, American International Airways Flight 808, Douglas DC-8-61, N814CK, U.S. Naval Air Station, Guantanamo Bay, Cuba, August 18, 1993*. Aircraft Accident Report NTSB/AAR-94/04. Washington, DC. For additional information on fatigue-related factors, see Federal Aviation Administration. 1998. *An Overview of the Scientific Literature Concerning Fatigue, Sleep, and the Circadian Cycle. Prepared for the FAA's Office of the Chief Scientific and Technical Advisor for Human Factors*.

waking day is between 14 and 16 hours and that lapses in vigilance increase and become longer if the normal waking day is extended.²¹¹ In addition, the Safety Board's 1994 study of flight crew-related major aviation accidents (see section 1.18.3.1) found that flight crews that had been awake for an average of about 13 hours made significantly more errors, especially procedural and tactical decision errors, than crews that had been awake for an average of about 5 hours. Thus, the flight crew's extended continuous hours of wakefulness was consistent with the development of fatigue.

Third, the 2350:44 accident time was nearly 2 hours after the time that both pilots went to bed the night before the accident and the captain's routine bedtime (between 2130 and 2200). According to a recognized expert in fatigue research who reviewed the flight and duty time and CVR data associated with this accident, because the flight crewmembers were conducting an approach at a time of night when they would have normally been asleep, their circadian systems were not actively promoting alertness in the last hours of their duty period. Thus, the time at which the accident occurred was consistent with the development of fatigue.²¹²

Research indicates that the ability to consider options decreases as people who are fatigued become fixated on a course of action or a desired outcome (which is also the case with situational stress, as discussed in section 2.2.3.1.1) and that it can be more difficult for a fatigued person to remember whether tasks have been accomplished.²¹³ In this accident, the flight crew did not consider delaying or diverting the landing, the first officer did not ensure that the autospoilers had been armed for landing, and the captain did not realize that he had not called for flaps 40. Also, automatic processes (such as radio calls and routine behavior) are affected less by fatigue than controlled processes (such as more

²¹⁰ The flight crew had accumulated 7 hours 49 minutes of flight time during this period. Because of differences in check-in times, the captain had accumulated 5 hours 24 minutes of ground time, and the first officer had accumulated 5 hours 44 minutes of ground time. Therefore, when the accident occurred, the captain's duty day was 13 hours 13 minutes, and the first officer's duty day was 13 hours 33 minutes. Both pilots' total continuous time awake at the time of the accident was at least 16 hours 21 minutes.

²¹¹ Kruger, G.P. 1989. "Sustained Work, Fatigue, Sleep Loss, and Performance: A Review of the Issues." *Work and Stress*. Vol. 3, pp. 129-141.

²¹² Continuous hours of wakefulness and accident time were also factors in the August 1997 Korean Air flight 801 accident in Guam (see section 1.18.6). The captain had been awake for 11 hours at the time of the crash, which occurred after midnight in the flight crew's home time zone (0142 Guam local time). The time of the crash was also several hours after the captain's (the flying pilot) normal bedtime.

²¹³ Caldwell, J.A. 1997. "Fatigue in the Aviation Environment: An Overview of the Causes and Effect as Well as Recommended Countermeasures." *Aviation, Space, and Environmental Medicine*. Vol. 68, pp. 932-938.

complex behavior, responses to new situations, and decision-making);²¹⁴ in this accident, however, both automatic and controlled processes were affected during the flight. Further, fatigue deteriorates performance on work-paced tasks that are characterized by time pressure and task-dependent sequences of activities, as demonstrated by the flight crew's failure to properly perform routine tasks during the final approach phase of flight. Therefore, the Safety Board concludes that the flight crew's degraded performance was consistent with known effects of fatigue.

Fatigue in transportation operations has been on the Safety Board's list of Most Wanted Safety Improvements since the list's initiation in September 1990. In May 1999, the Board issued a safety report that evaluated the DOT's efforts to address operator fatigue among the transportation modes, including aviation. (The Board first asked the DOT to upgrade flight and duty times and hours-of-service regulations for all modes in 1989.) The Board's report concluded that, despite acknowledgement by the DOT that fatigue is a significant factor in transportation accidents, little progress has been made to revise the hours-of-service regulations to incorporate the results of the latest research on fatigue and sleep issues. As a result, the Board issued Safety Recommendation A-99-45, asking the FAA to "establish within 2 years scientifically based hours-of-service regulations that set limits on hours of service, provide predictable work and rest schedules, and consider circadian rhythms and human sleep and rest requirements."

On July 15, 1999, the FAA stated that, on December 11, 1995, it issued Notice of Proposed Rulemaking (NPRM) 95-18, "Flight Crewmember Duty Period Limitations, Flight Time Limitations and Rest Requirements." The NPRM proposed amending existing regulations to establish one set of duty period limitations, flight time limitations, and rest requirements for flight crewmembers involved in air transportation. At an October 7, 1999, meeting with the Safety Board, FAA representatives stated that the FAA would not be able to meet the recommendation's time requirement for a new rule. On January 3, 2000, the Board indicated that, even though the NPRM was issued over 4 years earlier, the existing regulations concerning flight time regulations and rest requirements had not been upgraded. On December 5, 2000, the FAA stated that it planned to issue, in spring 2001, a supplementary NPRM that would address the issue of fatigue "concretely" and give the airlines the flexibility they need to operate. On April 26, 2001, the Board indicated that, in the 5 years since the issuance of NPRM 95-18 and the 1 1/2 years since the need for a supplemental NPRM was first communicated, the FAA has not taken action. As a result, Safety Recommendation A-99-45 was classified "Open—Unacceptable Response."

In a May 14, 2001, press release, the FAA stated that it "is confident that, overall, the airline industry complies with current FAA rules on pilot time limitations and rest requirements." The press release also stated the following:

On Nov. 20, 2000, the FAA responded to a letter from the Allied Pilots Association that set forth specific scenarios that could affect a very small number of all commercial pilots. The FAA's response was consistent with the agency's

²¹⁴ Humphrey, D.G.; Kramer, A.F.; and Stanny, R.R. 1994. "Influence of Extended Wakefulness on Automatic and Nonautomatic Processing." *Human Factors*. Vol. 36, pp. 652-669.

long-standing interpretation of the current rules. In summary, the FAA reiterated that each flight crew member must have a minimum of eight hours of rest in any 24-hour period that includes flight time. If a pilot's actual rest was less than nine hours in the 24-hour period, the next rest period must be lengthened to provide for the appropriate compensatory rest. Ensuring that all pilots, especially those on reserve duty, receive adequate rest is key to maintaining a safe aviation system.

On May 17, 2001, the FAA published a notice in the *Federal Register* that reiterated its interpretation of pilot flight time and rest rules. The notice stated that the FAA intended to enforce its rules in accordance with the interpretation and that, 6 months after the issuance of the notice, the FAA would review airline flight scheduling practices and deal stringently with any violations.²¹⁵

The Safety Board is encouraged by the FAA's increased efforts to enforce the current pilot flight time and rest rules. However, the Little Rock accident and the May 1999 American Eagle flight 4925 accident in New York (see section 1.18.6) highlight the need to expedite efforts to comprehensively address the issue of fatigue in aviation. Therefore, the Safety Board reiterates Safety Recommendation A-99-45.²¹⁶

2.3 Meteorological Support

2.3.1 Weather Information Provided by the Local Controller

The local controller was working all of the tower cab positions on the night of the accident and was not handling any other in-flight traffic, so flight 1420 had virtually his full attention. The controller responded promptly to all of the flight crew's requests. The CVR indicated that, between 2339:59 and 2340:12, the first officer and the controller discussed a change from runway 22L to 4R (after the wind shift to the northwest) and that the controller responded at 2340:20 with a heading change for vectors to the runway 4R ILS approach course. At 2344:30, the first officer informed the controller that the visual approach to runway 4R could not continue because of a cloud between the airplane and the airport, and the controller provided vectors for the ILS approach at 2344:39. The first officer told the controller, at 2345:47, that the airplane was getting close to the storm, and the controller returned with a new heading at 2345:52.

²¹⁵ In June 2001, the Air Transport Association and the Regional Airline Association asked the U.S. Court of Appeals for the District of Columbia to stay the pending enforcement of the FAA's interpretation of pilot flight time and rest rules, citing that enforcement of these rules constituted illegal rulemaking. On September 5, 2001, the U.S. Court of Appeals granted the Air Transport Association's and the Regional Airline Association's request for a stay of enforcement. As of October 29, 2001, the court was expected to hear arguments on this case in January 2002.

²¹⁶ The Safety Board notes that this safety recommendation asked the FAA to take the recommended action "within 2 years." By reiterating this safety recommendation, the Board is not suggesting that the recommended action should occur within 2 years from the date of this reiteration. Rather, because the original 2-year period has already expired, the Board urges the FAA to expedite its efforts to accomplish the action specified in this recommendation.

The controller also provided the flight crew with ongoing information about the wind direction and speed, including the two windshear alerts, while the airplane was approaching the airport and updated the wind information four times while the airplane was on final approach. The controller also kept the crew apprised of the progress of the thunderstorm. When the crew made initial contact with the tower, the controller indicated that a thunderstorm located northwest of the airport was moving through the area. He also informed the crew when the second part of the storm was moving through the area and when heavy rain was falling at the airport. Further, the controller alerted the crew when the RVR for runway 4R had decreased first to 3,000 feet and then to 1,600 feet and when ATIS information Romeo was no longer valid. The Safety Board could not find any instance in which the controller did not provide the flight crew with aviation weather information that was available to him in the tower or any delay in relaying this information, which is especially noteworthy considering that the weather conditions were rapidly changing during the last several minutes of flight 1420's approach to the airport.

The Safety Board concludes that the local controller provided appropriate, pertinent, and timely weather information to the flight crew regarding the conditions on approach to and at the airport. The controller's actions after the crash occurred are discussed in section 2.4.

2.3.1.1 Weather Information Depiction on Air Traffic Control Radar Systems

Although the controller accurately reported the weather information available in the tower, he appeared to lack confidence in the tower's radar weather depiction. For example, the controller asked the flight crew how the final approach to runway 22L looked on the airplane's radar presentation because the airplane's radar was "a lot better" than what he had available in the tower. In addition, the ATC transcript indicated that a controller from the Memphis ARTCC called the local controller to determine whether flights headed toward Little Rock would be able to land. As part of his response to this query, the local controller said, "my radar is not that good by the weather you know." The center controller's response to this comment was "better than ours."

The Safety Board notes that the radar used in ATC facilities was designed to depict air traffic; it was not designed to show weather. If near-real-time color weather radar had been available at ATC facilities, the Little Rock local controller would likely have been able to relay to the flight 1420 crew that a thunderstorm with extreme reflectivities had moved over the airport. In this case, the Board cannot determine whether such a report would have changed the flight crew's course of action because of the workload at the time that the report would have been received, as well as the flight crewmembers' impaired performance. Nevertheless, ATC near-real-time color weather radar information would enable controllers to provide flight crews with a better source of weather information than is currently available in the tower.

The Safety Board concludes that, if near-real-time color weather radar showing precipitation intensity were available, it would provide air traffic controllers with improved representation of weather conditions in their areas of responsibility. Therefore, the Safety Board believes that the FAA should incorporate, at all ATC facilities, a

near-real-time color weather radar display that shows detailed precipitation intensities. This display could be incorporated by configuring existing and planned Terminal Doppler Weather Radar (TDWR) or Weather Systems Processor (WSP) systems with this capability or by procuring, within 1 year, a commercial computer weather program currently available through the Internet or existing stand-alone computer hardware that displays the closest single-site Weather Surveillance Radar 1988 Doppler (WSR-88D) data or regional mosaic images.

2.3.2 Additional En Route Weather Information

2.3.2.1 Dispatch Office Weather Radar

After flight 1420 was underway (about 2240), the flight dispatcher transitioned from a flight-releasing to a flight-following role, which required him to provide the pilot-in-command with any safety-of-flight information that was pertinent to the flight's operation. However, the FAA does not generally provide Part 121 flight dispatch offices with access to TDWR real-time weather radar information. Although American's dispatchers receive high-resolution weather radar mosaic updates every 15 minutes on their workstations, the mosaics are delayed several minutes so that a clutter-free image can be presented. Even though the 15-minute updates indicate the organization and intensity of weather activity, the inherent delay in displaying the information (so that images can be compared with other weather observations and corrected for beam height and distance errors) prevents it from being depicted to the dispatcher in a timely manner. In this accident, the thunderstorm activity was moving rapidly, and the 15-minute radar updates could not adequately portray to the dispatcher the real-time conditions that flight 1420 could encounter.

Dallas/Fort Worth is 1 of the 41 airports at which the FAA has installed TDWR; Little Rock airport does not have the system, and the FAA does not plan to install the system there. The availability of TDWR data to the flight dispatcher would not have affected the outcome of the accident because TDWR presents only site-specific data; thus, the TDWR at Dallas/Fort Worth would not have provided the dispatcher with information about the weather conditions in the Little Rock airport area. However, for those airports equipped or planned to be equipped with TDWR, information from that radar system relayed by dispatchers would allow flight crews to have more detailed current weather information en route than their airborne weather radar systems are able to depict. This information would also help the dispatchers in planning, releasing, and following flights. WSP systems, when they become available (which the FAA expects to be in mid-2002), could provide the same benefits as TDWR for dispatchers located at airports without TDWR. (Little Rock is not among the airports that will be receiving the WSP system.)

The Safety Board concludes that the ability of flight dispatchers to provide timely and accurate weather support would be enhanced if they had access to TDWR information at airports where it is available and WSP information when the system becomes available. Therefore, the Safety Board believes that the FAA should provide U.S. air carriers operating under 14 CFR Part 121 access to TDWR, at airports where the system is

available, and access to the WSP system, when it becomes available, so that their flight dispatch offices can use this information in planning, releasing, and following flights during periods in which hazardous weather might impact safety of flight.

2.3.2.2 Center Weather Service Unit Staffing

Flight 1420 was handled by the Memphis ARTCC before the flight entered Little Rock airspace. The controllers at this center did not have access to real-time weather radar data, and no internal meteorological support was available to them because the center weather service unit (CWSU) had closed. The CWSU at the Memphis center was not staffed for 24-hour operation and had closed on the night of the accident about 2130, even though severe weather was predicted to affect the center's airspace. The CWSU meteorologists have access to WSR-88D weather products and thus could have provided the center controller with better information regarding the line of thunderstorms moving into the area. However, the availability of this information likely would not have affected the outcome of the accident because of the flight crew's impaired performance.

In its final report on the USAir flight 1016 accident, the Safety Board issued Safety Recommendations A-95-48 and -52, which asked the FAA and NWS, in cooperation with each other, to reevaluate the CWSU program and develop procedures to enable meteorologists to immediately disseminate information about rapidly developing hazardous weather conditions to Terminal Radar Approach Control and tower facilities. On October 22, 2001, and August 7, 2001, the Board acknowledged that the FAA and NWS, respectively, were working to address the actions specified in the recommendations but expressed concern that the work was not scheduled to be completed in a timely manner. Pending completion of the FAA's and NWS' planned actions, Safety Recommendations A-95-48 and -52 were classified "Open—Acceptable Response" and "Open—Unacceptable Response," respectively.

Even after the FAA and NWS have completed actions to address these recommendations, their intent cannot be fully achieved unless the CWSUs are adequately staffed at all times when rapidly developing hazardous weather conditions are possible. (In letters to the Safety Board regarding the progress in implementing these safety recommendations, neither agency has described such staffing for CWSUs.) The Safety Board concludes that CWSUs should be staffed at all times when any significant weather is predicted to affect their areas of operation, even if the weather is predicted to occur before or after normal operating hours. Therefore, the Safety Board believes that the FAA and the NWS, in cooperation with the other, should ensure that CWSUs are adequately staffed at all times when any significant weather is forecast.

2.3.2.3 Automated Surface Observing System Lockout Period

The lockout feature on the ASOS (that is, the time period between 47:20 and 53:20 after each hour when METARs [meteorological aerodrome reports] are prepared, edited, and transmitted) prevented the system from issuing pertinent weather information for the flight crew. If the lockout had not been in place, the system would have issued a special observation when the reduced visibility, heavy rain, and strong gusting winds associated

with the thunderstorm were detected. An additional special observation would have been issued when the visibility was further reduced. (The ASOS edit log indicated that a special observation at 2347:22 was canceled, and a 2350:31 special observation was recorded but not disseminated.)

The canceled observation would have likely indicated that the thunderstorm was at the airport and provided the flight crew with critical situational awareness information about the intensity of the storm. Because the accident airplane did not touch down until 2350:20, the information in the canceled 2347:22 special observation would have provided the flight crew with another indication that it was unsafe to land. The NWS advised the Safety Board that the next ASOS software implementation would eliminate the lockout period but that a target date for implementation has not been established because of problems with the software. The Safety Board concludes that the ASOS lockout period can prevent the relay of critical weather information to flight crews. Therefore, the Safety Board believes that the NWS should eliminate the ASOS lockout feature as soon as possible.

2.3.3 Airport Weather Equipment

2.3.3.1 Runway Visual Range System

Although the new-generation RVR system at Little Rock was designed to provide a more accurate reading than that provided by the previous RVR system, the Safety Board has two concerns about the new system. First, the RVR data were not directly transmitted to the ASOS. Second, the Board did not have access to 1-minute RVR data for this accident because an event log was not started.

The 1-minute RVR data were not included in the FAA's initial specifications for ASOS recorded data. As a result, certified weather observers are required to contact tower controllers to obtain the 10-minute average RVR readings, and the weather observers use this information in preparing METARs and SPECIs [special weather observations]. However, it is a recommended practice, under Annex 3 to the Convention on International Civil Aviation, for RVR data to be included in automated weather observation systems because of the data's importance to takeoff and landing operations.

This accident demonstrates how an RVR reading can decrease drastically in a short timeframe; the RVR reading of 3,000 feet at 2346:52 had decreased to 1,600 feet less than 1 1/2 minutes later. Because a change in visibility is one of the conditions that generates a special weather observation, the Safety Board concludes that RVR data should be directly reported to automated weather systems. Therefore, the Safety Board believes that the FAA should modify automated weather systems to accept RVR data directly from RVR sensors.

In addition, an RVR event log presents a total of 12 hours of the system's data. When an event log is started, the previous 2 hours of recorded RVR data are saved, and the next 10 hours of RVR data are recorded and saved. Thus, after this accident, an event log needed to be started no later than 0150 on June 2, 1999, to have preserved 1-minute RVR

data before and at the time of the accident. Because an event log was not started, these data were overwritten by newer data. Airways facility personnel are responsible for starting event logs; however, these personnel are not always present in the 2 hours after an event occurs. This small timeframe during which personnel are required to start event logs does not account for the possibility that RVR data will need to be retrieved.

The Safety Board concludes that the current 2-hour RVR archiving capability is inadequate to ensure that data can be preserved for future use. Therefore, the Safety Board believes that FAA should maintain at least a 48-hour archive of 1-minute RVR data. Such an archive could be accomplished either by modifying RVR systems or by interfacing RVR systems with local automated weather systems.

2.3.3.2 Low Level Windshear Alert System

The Low Level Windshear Alert System (LLWAS) alerts about 2339 and 2347 correctly detected actual windshear conditions associated with the gust front and other wind surges. No windshear alerts were current or were being issued at the time that flight 1420 touched down.²¹⁷

LLWAS centerfield wind sensors are typically mounted between 70 and 100 feet above field elevation; at Little Rock, the sensor is mounted at 70 feet. ASOS wind sensors are mounted at a standard height of 32 feet; thus, ASOS wind data may be more representative of the surface winds that will be present when an airplane is landing. At the time that flight 1420 landed on runway 4R, the ASOS was measuring the wind from 290° at 16 knots with gusts to 22 knots, resulting in a 5-knot tailwind component upon touchdown that increased the airplane's speed on the runway and affected the airplane's directional control and braking performance. As stated in section 2.2.2, the controller's last wind report of 320° at 23 knots (at 2349:53) would not have indicated to the flight crew the possibility of a tailwind at touchdown. Thus, the LLWAS centerfield wind information does not always reflect surface wind conditions, and the difference in height between LLWAS and ASOS sensors, in some cases, may be critical.

The FAA's Aeronautical Information Manual (AIM) Section 1, "Meteorology," Part 7, "Safety of Flight," includes only general information on the LLWAS. The information does not indicate that, in some circumstances, LLWAS centerfield wind information alone may not accurately represent the winds that are present at the runway surface. The information also does not caution that the LLWAS alerts at some airports (including Little Rock) currently do not distinguish between windshear and microburst events. (A future software change to LLWAS will allow all system models to differentiate between microburst and windshear alerts, but the only LLWAS systems that currently make this differentiation are those that are integrated with TDWR systems. Airports with such LLWAS systems include Dallas/Fort Worth, Chicago O'Hare, Denver International Airport, and Atlanta Hartsfield.)

²¹⁷ The LLWAS first detected winds associated with the microburst at 2351:30 and issued alerts from 2352:10 to 0005:10.

In addition, at the public hearing on this accident, the expert on LLWAS from the Massachusetts Institute of Technology's Lincoln Laboratory indicated his concern that pilots may be disregarding LLWAS alerts and continuing to operate into the terminal area because they perceive that the alerts are false and that no windshear threat exists. This situation may be occurring because pilots may not realize that the LLWAS sensors in use today are not the same as those used in the late 1970s through the late 1980s, which alerted when normal gusting winds were present. The latest LLWAS sensors include technologies to reduce such false alerts, yet this information also does not appear in the AIM.

The Safety Board concludes that, if detailed information on the LLWAS were contained in the FAA's AIM, pilots could have a better understanding of the system. Therefore, the Safety Board believes that the FAA should provide additional information on the LLWAS in the AIM, including that an LLWAS alert is a valid indicator of windshear or a microburst.

2.4 Emergency Response

The local controller reported that he called the Aircraft Rescue and Fire Fighting (ARFF) units on the crash phone about 2352 after several attempts to contact the flight crew after the airplane landed. The controller indicated the possibility of an accident at the end of runway 4R but did not specify which end of the runway. The ARFF units proceeded to the approach end of runway 4R, but the airplane was off the departure end of the runway. As a result, the ARFF units had to travel back to the taxiway at which they entered the runway and then proceed to the other end of the runway. The ARFF units located the airplane about 0003, 11 minutes after the initial call from the local controller. However, they did not arrive on scene until 5 minutes later, about 0008 (16 minutes after the initial notification), because they had to travel in the opposite direction to an access road, turn onto a perimeter road back in the direction of the accident site, stop to manually unlock a perimeter security gate, and then continue on the perimeter road to the accident site.

If the ARFF units had known the approximate location of the airplane when they left the fire station, the time spent traveling from the taxiway to the approach end of the runway and back would have been saved. The ARFF units reported that they were initially traveling very slowly because of the limited visibility toward the approach end of the runway and the unknown location of the airplane. The Safety Board recognizes that the controller could have provided a more precise description of the accident location to the ARFF units, especially since he knew the direction in which the airplane was landing and had seen the airplane travel past midfield. However, the Board also recognizes that the ARFF personnel could have queried the controller to see if he knew any additional information about the airplane's location.

The Safety Board concludes that part of the delay in locating the flight 1420 wreckage was preventable and that several minutes in the emergency response time might have been saved if the ARFF units had proceeded directly to the departure end of runway

4R. Because the delay can be partly attributed to the incomplete location information provided to the ARFF units by the local controller, the Safety Board believes that the FAA should issue a mandatory briefing item to tower controllers that describes the circumstances of this accident, including the interactions between the controller and ARFF crews. This briefing item should emphasize that location information provided to ARFF crews should be as complete and specific as possible to minimize opportunities for confusion. The Safety Board also believes that the FAA should amend FAA Order 7110.65, "Air Traffic Control," to require controllers to monitor the progress of ARFF crews responding to emergencies to ensure that the response is consistent with known location information. In addition, the Safety Board believes that the FAA should amend FAA Order 7210.3R, "Facility Operation and Administration," to direct tower managers to establish mutual annual briefings between ATC and ARFF personnel to ensure that these personnel have a common understanding of the local airport emergency plan and sections of the FAA's AC 150/5210-7C, "Aircraft Rescue and Firefighting Communications," that are applicable to local ATC/ARFF emergency response procedures.

The accident was not survivable for those who were seated on the forward left side of the airplane in the area of the collisions with the runway 22L approach lighting structure (the captain and the passengers in seats 3A and 8A) and those who were immediately exposed to lethal impact forces (seats 17B and 18A and B) or fire (seats 19A, B, and C) in the area where the fuselage separated.²¹⁸ The accident, however, was potentially survivable for the passenger fatalities in seats 27E and 28D.²¹⁹

Because the accident was potentially survivable for the passengers in seats 27E and 28D, the Safety Board considered whether a shorter ARFF response time could have prevented the fatalities but determined that the passengers' lives would not have been saved if emergency responders had arrived on scene earlier. Even with the shortest possible response time, the passenger in seat 28D would have already received the second- and third-degree burns to over half of her body and the severe inhalation injury from

²¹⁸ In a 2001 safety report, the Safety Board defined a survivable accident as follows: "For the accident to be deemed survivable, the forces transmitted to occupants through their seat and restraint system cannot exceed the limits of human tolerance to abrupt accelerations, and the structure in the occupants' immediate environment must remain substantially intact to the extent that a livable volume is provided for the occupants throughout the crash." See National Transportation Safety Board. 2001. *Survivability of Accidents Involving Part 121 U.S. Air Carrier Operations, 1983 Through 2000*. Safety Report NTSB/SR/01-01. Washington, DC.

²¹⁹ The passenger in seat 27E died of smoke and soot inhalation. After stating "that's everyone—that's all" in response to another passenger's query about whether anyone was still inside the cabin, the passenger in seat 27E continued farther aft in the cabin (for undetermined reasons) and was overcome by smoke; his body was found in the extreme aft part of the cabin on the right side. The passenger would have most likely survived if he had evacuated the airplane when he was near the right aft overwing exit. The passenger in seat 28D received serious burns when she evacuated the airplane through the left aft overwing exit and died 15 days later of complications from the burn injuries. This passenger would have likely survived if she had exited the airplane through the right aft overwing exit or the tailcone exit. The Safety Board recognizes that three other passengers who used the left aft overwing exit survived the accident, one of whom was burned severely. The passenger in seat 28D may have experienced a more intense fire than the other passengers because of the variable winds that were present or the progression of the fire.

which she later died. The passenger in seat 27E remained on the airplane and therefore needed to be rescued from the wreckage. However, the four ARFF personnel that responded to the accident were not available to enter the airplane because they were involved in positioning the fire trucks and operating fire suppression equipment.²²⁰ Thus, an interior search of the airplane could not be conducted until off-airport firefighters arrived on scene about 0022.

2.4.1 Aircraft Rescue and Fire Fighting Staffing Levels

The Safety Board could not determine whether the passenger in seat 27E would have survived if sufficient ARFF personnel had been available to perform a rescue. However, previous accidents in which the occupants' survival was aided by or depended on the abilities of rescue personnel to enter an airplane (see section 1.18.7.1) provide lessons learned that highlight the need for an adequate number of ARFF personnel to perform rescue operations.

The FAA's January 1997 final report, *Aircraft Rescue and Firefighting Services—Mission Response Study*, indicated that evacuation of an aircraft was a primary responsibility of the air carriers and that the carriers have crew complements trained for that function. This finding concerns the Safety Board because, in the event that crewmembers are incapacitated or the conditions aboard the airplane deteriorate to the point that the crew is forced to leave, the remaining airplane occupants must rely on ARFF personnel to assist in the evacuation. In fact, the first officer and two of the four flight attendants in the Little Rock accident sustained serious injuries and were unable to assist with the evacuation.

Title 14 CFR 139.319(j) requires that “sufficient rescue and firefighting personnel are available during all air carrier operations to operate the vehicles, meet the response times, and meet the minimum agent discharge rates required by this part.” However, the regulation does not contain any specific staffing requirement for ARFF units. Thus, the regulation does not ensure that ARFF units will be staffed at a level that would allow timely entry into an airplane for rescue and firefighting activities.

Insufficient ARFF staffing levels were demonstrated in two recent events. First, on October 10, 2000, a Canadair Challenger Model 604, C-FTBZ, owned by Bombardier Inc., and being operated as a test flight, crashed into terrain and collided with an airport perimeter fence during a failed takeoff from runway 19 at the Wichita Mid-Continent Airport, Kansas.²²¹ A fuel-fed fire erupted after the collision. Two ARFF fire trucks and three ARFF personnel responded within about 90 seconds and applied a mass application of firefighting agent to extinguish the exterior fire. The firefighters stated that they could hear screams for help coming from the cockpit. One of the ARFF trucks carried a

²²⁰ The Safety Board recognizes that Little Rock airport is now staffed with six ARFF personnel at all times.

²²¹ The description for this accident, CHI01MA006, can be found on the Safety Board's Web site at <<http://www.nts.gov>>.

“penetrating nozzle”;²²² however, the nozzle could not be used because two trained firefighters were required to operate it, and only one was available. (Two of the three personnel were occupied in their vehicles with firefighting activities.) The pilot and flight test engineer were killed, the copilot received serious injuries and died more than 1 month later, and the airplane was destroyed.

Second, on August 8, 2000, Air Tran flight 913, a DC-9-32, N838AT, made an emergency landing in Greensboro, North Carolina, because of dense smoke in the cockpit.²²³ The airplane landed successfully, and an emergency evacuation was conducted. All occupants were able to evacuate the airplane. Four crewmembers received minor injuries from smoke inhalation in flight, 1 passenger received a minor injury during the evacuation, and 1 crewmember and 57 passengers were uninjured. As with the flight 1420 emergency response, three ARFF vehicles and four ARFF personnel responded to the Air Tran event. If the occupants aboard the Air Tran flight had not been able to evacuate, there would not have been adequate ARFF resources to enter the airplane and rescue individuals. In fact, no ARFF personnel entered the airplane until after off-airport emergency responders arrived, despite the fire progressing through the airplane.

The Safety Board concludes that ARFF units may not be staffed at a level that enables ARFF personnel, upon arrival at an accident scene, to conduct exterior firefighting activities, an interior fire suppression attack, and a rescue mission. Therefore, the Safety Board believes that the FAA should amend 14 CFR 139.319(j) to require a minimum ARFF staffing level that would allow exterior firefighting and rapid entry into an airplane to perform interior firefighting and rescue of passengers and crewmembers.

2.4.2 Crash Detection and Location Technology

The accident airplane was not equipped with a technology, such as an emergency locator transmitter (ELT), that might have assisted the controller in directing the ARFF units to the airplane’s location after it crashed.²²⁴ Also, the ARFF vehicles were not equipped with the Driver’s Enhanced Vision System (DEVS), which was designed to help reduce emergency response times in poor visibility conditions such as those experienced after the flight 1420 crash. The DEVS includes a forward-looking infrared device, which searches for heat sources. Even though the heavy rain at the airport was cooling the plume

²²² A penetrating nozzle is a tool that is used to puncture the skin of a burning airplane and apply extinguishing agent to the interior of the airplane.

²²³ The description for this accident, DCA00MA079, can be found on the Safety Board’s Web site at <<http://www.nts.gov>>.

²²⁴ Tower facilities monitor ELT frequencies at all times. The Little Rock ARFF units did not have an ELT receiver.

of smoke from the postcrash fire, it is likely that the device would have detected the smoke plume sooner than the ARFF units were able to see it.²²⁵

The Safety Board has investigated other accidents in which the use of crash detection and location equipment would have significantly helped with the emergency response effort (see section 1.18.7.2). It is extremely important that ATC facilities receive immediate information about a downed aircraft and that ARFF units and other emergency responders arrive at the accident scene in the shortest possible time. ELTs, DEVS, and other current technologies that can be used to help detect, locate, or respond to downed aircraft offer the potential for improving emergency response times. The Safety Board concludes that a crash detection and location technology would help expedite the arrival of emergency responders at an accident scene, thus maximizing the possibility for saving lives and reducing the severity of injuries. Therefore, the Safety Board believes that the FAA should evaluate crash detection and location technologies, select the most promising candidate(s) for ensuring that emergency responders could expeditiously arrive at an accident scene, and implement a requirement to install and use the equipment.

2.4.3 Interagency Emergency Response Critique

Little Rock National Airport did not conduct a postaccident interagency emergency response critique shortly after the flight 1420 accident. Nine months after the accident, the airport completed individual critiques with all of the agencies involved with the emergency response and a group critique with some of these agencies. All of the agencies involved with the emergency response were invited to attend the group critique; however, the Little Rock Fire and Police Departments, the Little Rock Office of Emergency Services, and Metropolitan Emergency Medical Services did not attend. In addition, although the agenda for the group critique included many areas of discussion affecting all facets of an emergency response, the only documented information resulting from these discussions that was provided to the Safety Board was a summary of the hospitals' recommendation, observations, and concerns.

The FAA does not currently require airport operators to perform postaccident emergency response critiques. The Federal Railroad Administration (FRA), however, requires rail carriers to conduct postaccident emergency response critiques. Specifically, 49 CFR 239.105 requires that "each railroad operating passenger train service shall conduct a debriefing and critique session after each passenger train emergency situation" to determine the effectiveness of the railroad's emergency preparedness plan and amend or improve the plan according to the information gleaned. The FRA requires the critique to assess, among other items, how much time elapsed between the emergency situation and the notification to the emergency responders, whether the emergency responders arrived quickly on scene after receiving notification, and whether the emergency response was effective. The FRA further requires that the debriefing and critique session be conducted

²²⁵ As stated in section 1.18.4, the FAA requires a forward-looking infrared device to be installed on all of its new fire trucks that carry 1,500 or more gallons. DEVS is currently in use at Logan International Airport in Boston, Massachusetts.

within 60 days after the passenger train emergency situation and that the railroad maintain records of the session (including the names of all the participants) and make these records available to FRA representatives.

Although a formal postaccident interagency emergency response critique was not required by 14 CFR Part 139, such a critique, if performed in a timely manner after an aviation accident, would enable participants to take immediate, appropriate actions to rectify any identified emergency response deficiencies.

The Safety Board investigated two aviation accidents, 3 years apart, at Dallas/Fort Worth International Airport that demonstrate how corrective actions implemented after one accident response prevented a recurrence of the problem during a subsequent accident response. In the August 2, 1985, Delta flight 191 accident investigation (see section 1.18.5), the Board determined that, although the on-airport emergency response was timely and effective and contributed significantly to saving a number of lives, the amount of time required to complete all of the emergency notifications was excessive (45 minutes). The Board recommended that the Dallas/Fort Worth Airport Board improve its Airport Emergency Plan to provide for more efficient and timely notification of the mutual aid agencies and area hospitals.

On August 31, 1988, Delta flight 1141, a Boeing 727-232, N473DA, crashed during its takeoff roll.²²⁶ Of the 108 airplane occupants, 14 were killed, 26 were seriously injured, 50 received minor injuries, and 18 were uninjured. The airplane was destroyed by impact forces and postcrash fire. In its final report on this accident, the Board found that the time to complete emergency notifications, including those to the mutual aid agencies and hospitals, had been significantly reduced (21 minutes). The decreased notification time was partly attributed to the installation and use of the Automated Voice Notification System in the airport's Emergency Operations Center. The Board concluded that the corrective actions taken by the Dallas/Fort Worth Airport Board after the flight 191 accident "greatly improved" the communications and coordination of the ARFF personnel and medical units responding to the flight 1141 accident.

The Safety Board concludes that a timely postaccident interagency emergency response critique that identifies deficiencies that need corrective action and successes that should be repeated in similar circumstances would be beneficial for all parties involved in an aviation accident response. Therefore, the Safety Board believes that the FAA should develop specific criteria, using the FRA's requirements as guidance, to be evaluated during a postaccident interagency emergency response critique and amend 14 CFR Part 139 to require airport operators to conduct this critique within 60 days after any air carrier accident and provide the results of the critique to the FAA.

²²⁶ For more information, see National Transportation Safety Board. 1989. *Delta Air Lines, Inc., Boeing 727-232, N473DA, Dallas/Fort Worth International Airport, Texas, August 31, 1988*. Aircraft Accident Report NTSB/AAR/89-04. Washington, DC.

2.5 Airport Factors

2.5.1 Runway Safety Areas

Runway 4R/22L, which was opened in September 1991, has runway safety areas of 1,000 feet at the departure end of 22L and 450 feet at the departure end of 4R. Although the FAA's June 5, 1991, version of AC 150/5300-13 stated that the standard runway safety area was 1,000 feet, runway 4R/22L was exempt from this standard under the provisions of 14 CFR 139.309(a)(1), which allowed runways that had a safety area on December 31, 1987, to be maintained, as long as no reconstruction or significant expansion of the runway had begun after January 1, 1988.²²⁷ The Safety Board notes that, in this accident, an extra 550 feet at the departure end of runway 4R would not have prevented the airplane from departing the end of the runway or impacting the approach lighting system; however, the airplane's speed would have further decreased with an extra 550 feet at the end of the runway, resulting in a lower impact speed. Because safety areas of at least 1,000 feet would provide an extra margin of safety under most circumstances, the Board is concerned about runway safety areas that are less than the current FAA standard.

Another recent accident involved an overrun beyond the threshold of a runway with a nonstandard safety area. Specifically, on March 5, 2000, Southwest Airlines flight 1455, a Boeing 737-300, N668SW, departed the end of runway 8 during landing at Burbank-Glendale-Pasadena Airport, Burbank, California. The airplane traveled through a nonfrangible metal blast fence beyond the departure end of the runway and came to rest on a highway outside the airport perimeter. Of the 142 airplane occupants, 2 received serious injuries, 42 received minor injuries, and 98 were uninjured.²²⁸ The runway safety area at the approach (west) end of runway 8/26 is 200 feet; no safety area exists at the departure (east) end of the runway. As with runway 4R/22L in Little Rock, runway 8/26 in Burbank was exempt, under 14 CFR 139.309(a)(1), from the 1,000-foot runway safety area standard in AC 150/5300-13.

On December 13, 1994, the Safety Board issued Safety Recommendation A-94-211, which asked the FAA, among other things, to require that substandard runway safety areas be upgraded to AC 150/5300-13 minimum standards wherever possible.²²⁹ In its October 15, 1997, response, the FAA indicated that 25 percent of the runways at 14 CFR Part 139 certificated airports have safety areas that do not meet AC 150/5300-13 minimum standards but could with feasible improvements and that 17 percent have safety areas that could not be feasibly improved to meet the standard. However, the FAA stated that runway safety area improvement projects would be scheduled only as part of overall runway improvement projects because of the associated cost and infrequency of aircraft

²²⁷ Construction of runway 4R/22L began as early as September 1982. Work on the runway continued after January 1, 1988, but none of the efforts involved reconstruction or significant expansion.

²²⁸ The description for this accident, DCA00MA030, can be found on the Safety Board's Web site at <<http://www.nts.gov>>.

²²⁹ This recommendation was issued as a result of the April 27, 1994, Action Air Charters flight 990 accident in Stratford, Connecticut (see section 1.18.8.1).

overruns and undershoots. On February 10, 1999, the Board expressed its concern that the delay in runway safety area upgrades would allow nonstandard conditions to continue and classified Safety Recommendation A-94-211 "Closed—Unacceptable Action."

The Safety Board recognizes that the design of some airport runways makes it difficult for runway safety areas to be upgraded to the standards of AC 150/5300-13 and that those airport runways that can be upgraded may not be improved for some time based on the FAA's current plans. However, those runways should provide equivalent runway protection. One way to achieve this goal is to install a type of soft-ground aircraft arresting system, such as the Engineering Materials Arresting System (EMAS). The safety benefit of EMAS was demonstrated by the American Eagle flight 4925 accident when the airplane departed an 8,400-foot runway but was stopped approximately 248 feet into a 400-foot EMAS (see section 1.16.5).

According to a report by Engineered Arresting Systems Corporation, which developed EMAS, the flight 1420 airplane would not have been significantly slowed by a standard EMAS installed at the approach end of runway 22L because the airplane's track was outside the extended runway edges. Thus, the flight 1420 airplane would not have been able to use the full length of a standard EMAS. However, according to FAA AC 150/5220-22, "Engineered Materials Arresting System for Aircraft Overruns," most airplane runway overruns "come to rest within 1,000 feet of the runway end and between the extended edges of the runway." Therefore, the Safety Board continues to support the installation of EMAS, especially for those runways in which the safety area is less than the minimum standards established in AC 150/5300-13. The Board notes that an EMAS was installed at the departure end of runway 4R at Little Rock in the fall of 2000. The Board further notes that Little Rock airport is working with Federal and local government agencies to extend the runway safety area at the departure end of runway 4R to 1,000 feet by July 2002.

2.5.2 Nonfrangible Structures

The FAA determined that the runway 22L approach lighting system at Little Rock, which is located in a flood plain area of the Arkansas River, could not be retrofitted to a frangible design because of the possibility that moving water, ice, and floating debris would affect the structural integrity of the system. The Safety Board recognizes the current design limitations of this approach lighting system and acknowledges that, if the approach lighting system had been frangible, it is possible that the accident airplane would not have been stopped on the ground and would have gone into the Arkansas River. However, the Board also recognizes that frangible structures, because of their ability to break, distort, or yield on impact with aircraft, generally present less risk than nonfrangible ones. In this accident, the airplane's collision with the nonfrangible approach lighting system was the direct cause of the fatal blunt force trauma injuries sustained by the captain and the passengers in seats 3A and 8A and the destruction to the airplane on the left side of the fuselage.

In 1984, the Safety Board issued Safety Recommendation A-84-36, which asked the FAA to “initiate research and development activities to establish the feasibility of submerged low-impact resistance support structures for airport facilities and promulgate a design standard if such structures are found to be practical.” The FAA conducted research in this area with the National Institute of Standards and Technology. In October 1996, the FAA concluded that, with the current technology, any submerged low-impact frangible structure would most likely be destroyed by wave motion from small storms. Because of the FAA’s research activities, the Board classified the recommendation “Closed—Acceptable Action.”

The FAA has had an effort underway for some time to replace selected nonfrangible structures with frangible ones. However, technological advances since the time of the FAA/National Institute of Standards and Technology research activities, especially those involving the use of new materials, might allow some additional nonfrangible structures to be replaced by frangible ones. The Safety Board concludes that the development of recent technologies to convert nonfrangible structures to frangible ones would provide a safety benefit to airport facilities. Therefore, the Safety Board believes that the FAA should conduct research activities to determine if recent technological advances would enable submerged low-impact structures and other nonfrangible structures at airports to be converted to frangible ones.

2.6 American Airlines

2.6.1 Stabilized Approach Criteria

At the time of the accident, American’s only written guidance for MD-80 pilots regarding the stabilized approach concept was in the “Techniques” section of the DC-9 Operating Manual. The guidance indicated that the minimum recommended stabilized approach altitudes for instrument flight rules (IFR) and visual flight rules (VFR) conditions were 1,000 and 500 feet, respectively, and that landing flaps were to be selected by 1,000 feet afl. The guidance also stated that, before descending below the specified minimum stabilized approach altitude, the airplane was to be in the final landing configuration (gear down and final flaps), on approach speed, on the proper flightpath, at the proper sink rate, and at stabilized thrust; these conditions were expected to be maintained throughout the rest of the approach. However, the guidance did not define what was meant by “on” approach speed, “on” the proper flightpath, and “at” the proper sink rate. In addition, the guidance did not describe the necessary flight crew actions if the stabilized approach criteria were not met. Further, information presented in the “Techniques” section was not considered by American to be required procedures but rather suggested ways of accomplishing a task.²³⁰

The Safety Board notes that American revised its stabilized approach criteria after the accident and included this information in both its Airplane Flight Manual and DC-9 Operating Manual. The revised company procedures state that the airplane must be “at approach speed (V_{ref} plus additives)” rather than “on approach speed.” The procedures

also state that the minimum stabilized approach height is 1,000 feet afl in instrument meteorological conditions and 500 feet afl in visual meteorological conditions rather than present minimum recommended stabilized approach altitudes for IFR and VFR conditions. In addition, the procedures explicitly state that a go-around is required if stabilized approach requirements cannot be maintained until landing.

At the public hearing on this accident, the first officer discussed the training and guidance that he had received at American concerning a decision to execute a go-around. The first officer indicated that this decision was based on the stabilized approach theory. He stated that, if the sink rate was excessive or if the airplane was deviated to the left or right of course (among other criteria), then the approach would not meet the stabilized approach definition and a go-around should be performed.

American's flight manual contains the only written guidance regarding the performance of a missed approach. At the time of the accident, the manual stated that, when a landing cannot be accomplished, the pilot must comply with the missed approach procedure, or an alternate missed approach procedure specified by ATC, upon reaching the missed approach point defined on the approach chart. The missed approach procedures were revised on August 15, 1999, to state that American Airlines has a "no-fault go-around policy" and recognize that a successful approach can end in a missed approach. The revised procedures require captains to execute or order a missed approach if the aircraft is not stabilized by 1,000 feet afl (in IFR conditions) or 500 feet afl (in VFR conditions) or if the captain believes that a safe landing cannot be accomplished within the touchdown zone or that the airplane cannot be stopped within the available runway length.

The Safety Board acknowledges that American revised its missed approach procedures to ensure that its pilots are aware that they will not be faulted if they perform a missed approach and that the revised procedures specify the altitude at which a go-around is required if an approach is not stabilized. However, the new stabilized approach requirements still do not explicitly state what is meant by "proper" flightpath and "proper" sink rate. Further, the requirements do not provide pilots with specific amounts of glideslope and localizer displacement for determining whether an approach is stabilized. The new requirements also do not contain specific, corrective actions for pilots to take if an approach becomes unstabilized before the required minimum stabilized approach heights.²³¹ Thus, the Safety Board concludes that American Airlines has insufficient

²³⁰ The Safety Board recognizes that American plans to integrate the "Techniques" section with the "Normals" section of the DC-9 Operating Manual, which contains required, rather than suggested, procedures for accomplishing tasks. However, American did not provide any timetable for combining the two sections, stating at the public hearing that it was "gradually" editing out the "Techniques" section. Thus, the minimal stabilized approach guidance that does exist may remain only as a suggested procedure for some time. Even after the information is placed in the "Normals" section, it will still lack the necessary specificity to assist pilots in recognizing an unstabilized approach.

²³¹ In the February 6, 1997, American Airlines flight 699 accident in St. John's, Antigua, the Safety Board determined that a contributing factor in the accident was American's inadequate procedures to address corrective actions for approaches that become unstabilized. The description for this accident, DCA97LA027, can be found on the Safety Board's Web site at <<http://www.nts.gov>>.

guidance to assist its pilots in performing a stabilized approach and recognizing when an approach has become unstabilized.

On August 29, 1997, the Safety Board issued Safety Recommendation A-97-85, which asked the FAA to require all 14 CFR Part 121 and 135 operators to review and revise their company operations manuals to more clearly define terms that are critical for safety-of-flight decision-making, such as “stabilized approach.”²³² On May 26, 1998, the FAA issued Flight Standards Handbook Bulletin for Air Transportation (HBAT) 98-22, “Stabilized Approaches,” which directed 14 CFR Part 121 and 135 POIs to review operators’ training and operations manuals to ensure that they addressed, among other things, the minimum requirements for a stabilized approach and the immediate actions that needed to be taken if the stabilized approach conditions were not met. On the basis of the FAA’s actions, the Safety Board classified Safety Recommendation A-97-85 “Closed—Acceptable Action” on November 20, 1998.

The Safety Board is concerned that, even with the requirement for POIs to ensure that their carrier’s stabilized approach guidance is in accordance with Flight Standards HBAT 98-22, some carriers may still have stabilized approach guidance that lacks specificity (as demonstrated by American’s revised MD-80 stabilized approach guidance.) In addition, guidance to air carriers on stabilized approach criteria in the FAA’s Air Transportation Operations Inspector’s Handbook is not sufficiently detailed to ensure that carriers provide their pilots with defined guidelines for determining a stabilized approach and deciding when a missed approach is necessary. The Safety Board concludes that, because a stabilized approach is a critical part of safe flight operations, it is imperative that air carriers have specific stabilized approach criteria. Therefore, the Safety Board believes that the FAA should define detailed parameters for a stabilized approach, develop detailed criteria indicating when a missed approach should be performed, and ensure that all 14 CFR Part 121 and 135 carriers include this information in their flight manuals and training programs.

2.6.2 Spoiler System Training

During observations of day 6 (takeoffs and landings) of American Airlines’ MD-80 simulator training sessions, spoiler system training deficiencies were noted. One session presented no landings in which the spoilers had failed to deploy. The other session presented seven landings in which the spoilers had failed to deploy, but none of the trainees had called out that the spoilers had not extended. As indicated in section 2.2.2.1.3, American’s MD-80 Fleet Manager at the time of the accident and several company MD-80 check airmen indicated that pilots were trained to announce if the spoilers failed to automatically extend, yet the instructor did not point out to the students that they had failed to make this announcement.

²³² This recommendation was issued as a result of the October 19, 1996, Delta Air Lines flight 554 accident in New York (see section 1.18.8.2).

The spoilers were manually deployed in only two of the failed spoiler landings, but a first officer trainee was the pilot who extended the spoilers. This action was contrary to American's policy, which indicated that the captain was to extend the spoilers if they failed to deploy, regardless of which pilot was making the landing.

Further evidence of problems with American's spoiler system training came to light after the Palm Springs incident. During the 8 months in between the Little Rock accident and the Palm Springs incident, company managers had been aware of the spoiler deployment problems experienced by the Little Rock pilots. In fact, the former MD-80 Fleet Manager testified at the public hearing that spoiler system training now included recognizing the lack of spoiler extensions and performing the appropriate response.

The Palm Springs captain had completed MD-80 captain upgrade training in November 1999, during which time he would have attended day 6 of the simulator training and should have been instructed on the revised simulator spoiler training procedures. The Palm Springs first officer had completed MD-80 recurrent training in August 1999, during which time he should have also been instructed on the revised simulator spoiler training procedures. However, both flight crewmembers in the Palm Springs incident failed to verify that the spoilers had automatically deployed after landing, and the captain failed to manually extend the spoilers when they did not deploy. The Safety Board recognizes that, on February 23, 2000 (1 week after the Palm Springs incident), American revised its DC-9 Operating Manual to prevent a situation similar to the Little Rock and Palm Springs events from recurring. The revisions specified that the nonflying pilot was responsible for making a "deployed" or "no spoilers" callout at touchdown and that the captain was always responsible for deploying the spoilers if they did not extend after touchdown.

2.6.3 Spoiler and Braking Systems Procedures

At the time of the accident, American had not adopted Boeing's MD-80 spoiler deployment and autobrake procedures. Boeing's procedures recommended a "no spoilers" callout by the nonflying pilot if the spoiler handle did not move aft after touchdown and the use of maximum autobrakes for landings on wet or slippery runways. As stated in section 2.2.2.1.3, the flight crew's failure to detect that the spoilers had not deployed at touchdown might have been avoided if a procedure similar to Boeing's had been in place at American at the time. As stated in section 2.2.2.3, if the spoilers had deployed and the flight crew had selected maximum autobrakes for the landing, initial brake application could have occurred about 4 seconds sooner.

At the public hearing on this accident, Boeing's MD-80 Chief Pilot for Flight Operations indicated that operators are not required to adopt the operating procedures in Boeing's FCOM and that operators, along with their POIs, can change the procedures. The Chief Pilot also indicated that most, if not all, of the domestic operators coordinate with the manufacturer—normally by requesting a letter of no technical objection—before making any changes to their flight manual, even though there is no legal requirement to do so. In an April 20, 2000, letter to the Safety Board, Boeing indicated that it could not find

any record of issuing a letter of no technical objection to American regarding alteration of the manufacturer's recommended spoiler deployment or autobrake procedures.

On November 30, 1998, Safety Recommendation A-98-102 was issued because air carriers had the prerogative not to adopt certain manufacturer procedures without clear written justification.²³³ Safety Recommendation A-98-102 asked the FAA to "require air carriers to adopt the operating procedures contained in the manufacturer's airplane flight manual and subsequent approved revisions or provide written justification that an equivalent safety level results from an alternate procedure." In response to this recommendation, the FAA issued, in May 1999, the Joint Flight Standards HBAT, Airworthiness, and General Aviation, Flight Standards Policy—Company Operating Manuals and Company Training Program Revisions for Compliance. The handbook bulletin directed that POIs encourage their operators to (1) have a reliable delivery system in place for flight manual revisions, which ensures that the operators receive the revisions within 30 calendar days of approval, and (2) develop an action plan to notify, in writing, respective POIs of new flight manual revisions within 15 days after receipt.

In addition, on July 7, 2000, the FAA stated that it had initiated an NPRM proposing to revise 14 CFR Part 121, Subparts N and O, to reflect the policy included in the May 1999 Joint Flight Standards HBAT, Airworthiness, and General Aviation, Flight Standards Policy—Company Operating Manuals and Company Training Program Revisions for Compliance. On January 12, 2001, the Safety Board acknowledged the FAA's actions and stated that, pending the issuance of the NPRM and implementation of the proposed regulation, Safety Recommendation A-98-102 was classified "Open—Acceptable Response." On August 2, 2001, the FAA stated that it was continuing to develop the NPRM.

At the public hearing on this accident, the POI for American indicated that a carrier might choose not to make a manufacturer's suggested change because of the way that the carrier has configured the particular airplane. However, it is critical that the carrier provide written justification to the FAA regarding the reasons for not making a change or for implementing an alternative procedure in case the manufacturer's performance data do not support the carrier's justification. It is also critical that the carrier make its POI and respective aircrew program manager (APM) aware of any manufacturer's recommended procedure that is not being adopted or is being altered.

The Safety Board recognizes that American, since the time of the accident, has revised its DC-9 Operating Manual to include spoiler deployment and autobrake procedures similar to Boeing's. The Board further recognizes that the FAA has taken positive steps toward implementing the intent of this recommendation. However, this accident highlights the need for timely action to ensure that pilots are operating airplanes according to procedures that reflect the manufacturer's safest operating practices. Therefore, the Safety Board reiterates Safety Recommendation A-98-102.

²³³ This recommendation was issued as a result of the January 9, 1997, Comair flight 3272 accident near Monroe, Michigan (see section 1.18.8.3).

2.7 Federal Aviation Administration Oversight

Within the FAA's Certificate Management Office for the AMR Corporation, the POI for American Airlines is responsible for the overall oversight of American's training and line operations and for approving training and flight manuals and their revisions. At the public hearing, the POI stated that he needed more inspectors to conduct surveillance but that a hiring freeze was in effect. The POI also indicated that he needed almost double the number of air safety inspectors he had in his office at the time and that his inability to hire more inspectors had severely impacted his office's surveillance activities. Further, the POI expressed concern that his office did not have geographic air safety inspectors in some locations where American has a large volume of operations.

An APM and an Assistant APM were responsible for providing oversight of American's MD-80 fleet. This oversight responsibility included reviewing and approving the contents of the flight manuals, monitoring the training program, reviewing recommended changes to the manuals and training program, and monitoring daily line operations. The APM indicated that his ability to oversee American's MD-80 fleet was affected by personnel constraints. For example, the APM stated that, because he and the Assistant APM were the only ones responsible for observing American's MD-80 training, they were "spread thin" and found it "extremely difficult" to observe all facets of the training program. In addition, the APM stated that budget constraints had limited the amount of oversight that could be performed and the locations where it could be performed.

The APM said that a thorough job of oversight required many personnel, which he did not have. According to the APM, selected check airmen from American Airlines, named aircrew program designees, performed most of the airman certification activities under the APM's supervision. Also, senior designated examiners at American were responsible for observing every company check airman and simulator instructor at least once a year. Further, the APM relied heavily on American Airlines to ensure standardization in its simulator training program.

It is clear that the FAA's oversight responsibilities for American's MD-80 training were highly dependent on the work of American's check airmen, aircrew program designees, and senior designated examiners. Although the Safety Board acknowledges that American and the FAA's Certificate Management Office for the AMR Corporation have developed a cooperative working relationship with each other, the Board is concerned about the lack of direct FAA oversight of American's MD-80 fleet. The problems found during observations of American's simulator training sessions (for example, the students' use of reverse thrust above 1.3 EPR on wet runways and failure to notice the lack of spoiler extension) might have been detected earlier if the FAA had been directly monitoring the training.

In its final report on the USAir flight 1016 accident, the Safety Board expressed its concern about the relationship between USAir and the FAA POI for USAir. Specifically, the Board faulted the POI for relying entirely on USAir to rectify a situation in which

many pilots were not in compliance with a standard operating procedure. The Board stated that “overreliance on the air carrier to carry out its [the FAA’s] responsibility could limit the POI’s ability to maintain an adequate oversight program and monitor the operation for noncompliance.” The flight 1420 accident has brought attention to another circumstance of FAA overreliance on a carrier to perform oversight activities. Independent oversight for American’s MD-80 fleet is necessary, especially because three-quarters of the new upgrade captains and one-half of the new hire pilots are assigned to the MD-80 fleet, according to the APM.

The Safety Board concludes that effective FAA oversight of American Airlines’ MD-80 flight training and flight operations has not occurred. In light of the comments made by the POI for American at the public hearing, the Board is concerned that similar oversight problems might be occurring in the company’s other fleets. Therefore, the Safety Board believes that the FAA should provide additional personnel to accomplish direct oversight of American Airlines’ flight training and flight operations and include the POI for American in decisions regarding where these personnel are to be placed. In addition, the Board encourages the FAA to review oversight staffing levels at all Part 121 and 135 carriers and make appropriate changes to ensure that effective oversight of flight training and flight operations is occurring.

3. Conclusions

3.1 Findings

1. The captain and the first officer of American Airlines flight 1420 were properly certificated and qualified under Federal and company requirements. No evidence indicated any preexisting medical or behavioral conditions that might have adversely affected the flight crew's performance during the accident flight.
2. The accident airplane was properly certified, equipped, and maintained in accordance with Federal regulations and approved company procedures. No evidence indicated preexisting engine, system, or structural failures.
3. During the descent into the terminal area, the flight crewmembers could have reasonably believed that they could reach the airport before the thunderstorm.
4. Because the first officer was able to maintain visual contact with the runway as the airplane was vectored for the final approach course, both flight crewmembers might still have believed that flight 1420 could arrive at the airport before the thunderstorm.
5. When the second windshear alert was received, the flight crew should have recognized that the approach to runway 4R should not continue because the maximum crosswind component for conducting the landing had been exceeded.
6. Because of the flight crew's failure to adequately prepare for the approach and the rapidly deteriorating weather conditions, the likelihood of safely completing the approach was decreasing, and the need to take a different course of action was progressively increasing; as a result, the flight crew should have abandoned the approach.
7. Dynamic or reverted rubber hydroplaning did not occur during the accident airplane's landing rollout.
8. The autospoiler system operated properly, and the spoilers did not automatically deploy because the spoiler handle was not armed by either pilot before landing.
9. A high level of operational redundancy should exist to ensure that spoiler arming has been completed before landing.
10. The flight crew failed to verify that the spoilers had automatically deployed after landing, and the captain failed to manually extend the spoilers when they did not deploy.

11. Because spoiler deployment is critical for optimal landing performance, procedures to ensure that the spoilers have deployed after touchdown should be a required part of all air carriers' landing operations.
12. The lack of spoiler deployment led directly to the flight crew's problems in stopping the airplane within the remaining available runway length and maintaining directional control of the airplane on the runway.
13. The use of reverse thrust at levels greater than 1.3 engine pressure ratio significantly reduced the effectiveness of the airplane's rudder and vertical stabilizer and resulted in further directional control problems on the runway.
14. The maximum reverse thrust for MD-80 landings on wet or slippery runways should be 1.3 engine pressure ratio, except when directional control can be sacrificed for a marginal increase in deceleration.
15. Automatic brake systems reduce pilot workload during landings in wet, slippery, or high crosswind conditions.
16. The lack of spoiler deployment was the single most important factor in the flight crew's inability to stop the accident airplane within the available runway length.
17. The flight crewmembers' performance during the accident flight was degraded, as evidenced by their operational errors and impaired decision-making.
18. The flight crewmembers' focus on expediting the landing because of the impending weather contributed to their degraded performance.
19. Aircraft penetration of thunderstorms occurs industry-wide.
20. The flight crew's degraded performance was consistent with known effects of fatigue.
21. The local controller provided appropriate, pertinent, and timely weather information to the flight crew regarding the conditions on approach to and at the airport.
22. If near-real-time color weather radar showing precipitation intensity were available, it would provide air traffic controllers with improved representation of weather conditions in their areas of responsibility.
23. The ability of flight dispatchers to provide timely and accurate weather support would be enhanced if they had access to Terminal Doppler Weather Radar information at airports where it is available and Weather Systems Processor information when the system becomes available.
24. Center Weather Service Units should be staffed at all times when any significant weather is predicted to affect their areas of operation, even if the weather is predicted to occur before or after normal operating hours.

25. The Automated Surface Observing System lockout period can prevent the relay of critical weather information to flight crews.
26. Runway visual range data should be directly reported to automated weather systems.
27. The current 2-hour runway visual range archiving capability is inadequate to ensure that data can be preserved for future use.
28. If detailed information on the Low Level Windshear Alert System were contained in the Federal Aviation Administration's Aeronautical Information Manual, pilots could have a better understanding of the system.
29. Part of the delay in locating the flight 1420 wreckage was preventable, and several minutes in the emergency response time might have been saved if the Aircraft Rescue and Fire Fighting units had proceeded directly to the departure end of runway 4R.
30. Aircraft Rescue and Fire Fighting (ARFF) units may not be staffed at a level that enables ARFF personnel, upon arrival at an accident scene, to conduct exterior firefighting activities, an interior fire suppression attack, and a rescue mission.
31. A crash detection and location technology would help expedite the arrival of emergency responders at an accident scene, thus maximizing the possibility for saving lives and reducing the severity of injuries.
32. A timely postaccident interagency emergency response critique that identifies deficiencies that need corrective action and successes that should be repeated in similar circumstances would be beneficial for all parties involved in an aviation accident response.
33. The development of recent technologies to convert nonfrangible structures to frangible ones would provide a safety benefit to airport facilities.
34. American Airlines has insufficient guidance to assist its pilots in performing a stabilized approach and recognizing when an approach has become unstabilized.
35. Because a stabilized approach is a critical part of safe flight operations, it is imperative that air carriers have specific stabilized approach criteria.
36. Effective Federal Aviation Administration oversight of American Airlines' MD-80 training and line operations has not occurred.

3.2 Probable Cause

The National Transportation Safety Board determines that the probable causes of this accident were the flight crew's failure to discontinue the approach when severe thunderstorms and their associated hazards to flight operations had moved into the airport area and the crew's failure to ensure that the spoilers had extended after touchdown.

Contributing to the accident were the flight crew's (1) impaired performance resulting from fatigue and the situational stress associated with the intent to land under the circumstances, (2) continuation of the approach to a landing when the company's maximum crosswind component was exceeded, and (3) use of reverse thrust greater than 1.3 engine pressure ratio after landing.

4. Recommendations

As a result of the investigation of this accident, the National Transportation Safety Board makes the following recommendations:

—To the Federal Aviation Administration

For all 14 *Code of Federal Regulations* Part 121 and 135 operators of airplanes equipped with automatic spoiler systems, require dual crewmember confirmation before landing that the spoilers have been armed, and verify that these operators include this procedure in their flight manuals, checklists, and training programs. (A-01-49)

For all 14 *Code of Federal Regulations* Part 121 and 135 operators, require a callout if the spoilers do not automatically or manually deploy during landing and a callout when the spoilers have deployed, and verify that these operators include these procedures in their flight manuals, checklists, and training programs. The procedures should clearly identify which pilot is responsible for making these callouts and which pilot is responsible for deploying the spoilers if they do not automatically or manually deploy. (A-01-50)

Issue a flight standards information bulletin that requires the use of 1.3 engine pressure ratio as the maximum reverse thrust power for MD-80 series airplanes under wet or slippery runway conditions, except in an emergency in which directional control can be sacrificed for decreased stopping distance. (A-01-51)

Require principal operations inspectors of all operators of MD-80 series airplanes to review and determine that these operators' flight manuals and training programs contain information on the decrease in rudder effectiveness when reverse thrust power in excess of 1.3 engine pressure ratio is applied. (A-01-52)

Require all operators of MD-80 series airplanes to require a callout if reverse thrust power exceeds the operators' specific engine pressure ratio settings. (A-01-53)

For all 14 *Code of Federal Regulations* Part 121 and 135 operators, require the use of automatic brakes, if available and operative, for landings during wet, slippery, or high crosswind conditions, and verify that these operators include this procedure in their flight manuals, checklists, and training programs. (A-01-54)

Establish a joint Government-industry working group to address, understand, and develop effective operational strategies and guidance to reduce thunderstorm penetrations, and verify that these strategies and guidance materials are incorporated into air carrier flight manuals and training programs as the strategies become available. The working group should focus its efforts on all facets of the airspace system, including ground- and cockpit-based solutions. The near-term goal of the working group should be to establish clear and objective criteria to facilitate recognition of cues associated with severe convective activity and guidance to improve flight crew decision-making. (A-01-55)

Incorporate, at all air traffic control facilities, a near-real-time color weather radar display that shows detailed precipitation intensities. This display could be incorporated by configuring existing and planned Terminal Doppler Weather Radar or Weather Systems Processor systems with this capability or by procuring, within 1 year, a commercial computer weather program currently available through the Internet or existing stand-alone computer hardware that displays the closest single-site Weather Surveillance Radar 1988 Doppler data or regional mosaic images. (A-01-56)

Provide U.S. air carriers operating under 14 *Code of Federal Regulations* Part 121 access to Terminal Doppler Weather Radar, at airports where the system is available, and access to the Weather Systems Processor, when it becomes available, so that their flight dispatch offices can use this information in planning, releasing, and following flights during periods in which hazardous weather might impact safety of flight. (A-01-57)

In cooperation with the National Weather Service, ensure that Center Weather Service Units are adequately staffed at all times when any significant weather is forecast. (A-01-58)

Modify automated weather systems to accept runway visual range (RVR) data directly from RVR sensors. (A-01-59)

Maintain at least a 48-hour archive of 1-minute runway visual range data. (A-01-60)

Provide additional information on the Low Level Windshear Alert System (LLWAS) in the Aeronautical Information Manual, including that an LLWAS alert is a valid indicator of windshear or a microburst. (A-01-61)

Issue a mandatory briefing item to tower controllers that describes the circumstances of this accident, including the interactions between the controller and Aircraft Rescue and Fire Fighting (ARFF) crews. This briefing item should emphasize that location information provided to ARFF crews should be as complete and specific as possible to minimize opportunities for confusion. (A-01-62)

Amend Federal Aviation Administration Order 7110.65, "Air Traffic Control," to require controllers to monitor the progress of Aircraft Rescue and Fire Fighting crews responding to emergencies to ensure that the response is consistent with known location information. (A-01-63)

Amend Federal Aviation Administration (FAA) Order 7210.3R, "Facility Operation and Administration," to direct tower managers to establish mutual annual briefings between air traffic control (ATC) and Aircraft Rescue and Fire Fighting (ARFF) personnel to ensure that these personnel have a common understanding of the local airport emergency plan and sections of the FAA's Advisory Circular 150/5210-7C, "Aircraft Rescue and Firefighting Communications," that are applicable to local ATC/ARFF emergency response procedures. (A-01-64)

Amend 14 *Code of Federal Regulations* 139.319(j) to require a minimum Aircraft Rescue and Fire Fighting staffing level that would allow exterior firefighting and rapid entry into an airplane to perform interior firefighting and rescue of passengers and crewmembers. (A-01-65)

Evaluate crash detection and location technologies, select the most promising candidate(s) for ensuring that emergency responders could expeditiously arrive at an accident scene, and implement a requirement to install and use the equipment. (A-01-66)

Develop specific criteria, using the Federal Railroad Administration's requirements as guidance, to be evaluated during a postaccident interagency emergency response critique, and amend 14 *Code of Federal Regulations* Part 139 to require airport operators to conduct this critique within 60 days after any air carrier accident and provide the results of the critique to the Federal Aviation Administration. (A-01-67)

Conduct research activities to determine if recent technological advances would enable submerged low-impact structures and other nonfrangible structures at airports to be converted to frangible ones. (A-01-68)

Define detailed parameters for a stabilized approach, develop detailed criteria indicating when a missed approach should be performed, and ensure that all 14 *Code of Federal Regulations* Part 121 and 135 carriers include this information in their flight manuals and training programs. (A-01-69)

Provide additional personnel to accomplish direct oversight of American Airlines' flight training and flight operations, and include the principal operations inspector for American in decisions regarding where these personnel are to be placed. (A-01-70)

—To the National Weather Service

In cooperation with the Federal Aviation Administration, ensure that Center Weather Service Units are adequately staffed at all times when any significant weather is forecast. (A-01-71)

Eliminate the Automated Surface Observing System lockout feature as soon as possible. (A-01-72)

In addition, the Safety Board reiterates the following recommendations to the Federal Aviation Administration:

Establish within 2 years²³⁴ scientifically based hours-of-service regulations that set limits on hours of service, provide predictable work and rest schedules, and consider circadian rhythms and human sleep and rest requirements (A-99-45)

Require air carriers to adopt the operating procedures contained in the manufacturer's airplane flight manual and subsequent approved revisions or provide written justification that an equivalent safety level results from an alternate procedure. (A-98-102)

BY THE NATIONAL TRANSPORTATION SAFETY BOARD

MARION C. BLAKEY
Chairman

CAROL J. CARMODY
Vice Chairman

JOHN A. HAMMERSCHMIDT
Member

JOHN J. GOGLIA
Member

GEORGE W. BLACK, JR.
Member

Adopted: October 23, 2001

²³⁴ As previously stated, because the 2-year timeframe specified in this recommendation has already expired, the Safety Board urges the FAA to expedite its efforts to accomplish this recommendation.

5. Appendixes

Appendix A Investigation and Hearing

Investigation

The National Transportation Safety Board was initially notified of this accident on June 2, 1999, about 0115 eastern daylight time. A full go-team was assembled and departed about 0430 eastern daylight time from Ronald Reagan National Airport in Washington, D.C., for Little Rock. The team and arrived on scene about 0700 eastern daylight time (0600 central daylight time). Accompanying the team to Little Rock was Board Member George Black.

The following investigative teams were formed: Aircraft Operations, Human Performance, Aircraft Structures, Aircraft Systems, Powerplants, Maintenance Records, Air Traffic Control, Meteorology, Aircraft Performance, Survival Factors, and Airport/Search/Fire/Rescue. Specialists were also assigned to conduct the readout of the FDR and transcribe the CVR in the Safety Board's laboratory in Washington, D.C.

Parties to the investigation were the Federal Aviation Administration (FAA), American Airlines, the Boeing Commercial Airplane Group, Pratt & Whitney Engines, the Allied Pilots Association, the Association of Professional Flight Attendants, the National Air Traffic Controllers Association, the National Weather Service, Little Rock National Airport, and Little Rock Fire Department.

Public Hearing

The Safety Board held a public hearing on this accident on January 26 through 28, 2000, in Little Rock. Former Chairman Jim Hall presided over the public hearing. The issues presented at the hearing were flight crew decision-making, availability and dissemination of weather data, aircraft performance, passenger safety and emergency response, runway overrun protection, American Airlines' operational practices and procedures, American's internal oversight, and the FAA's oversight of American.

Parties to the public hearing were the FAA, American, Boeing, the Allied Pilots Association, the Association of Professional Flight Attendants, the National Weather Service, Little Rock National Airport, and Little Rock Fire Department.

Appendix B

Cockpit Voice Recorder Transcript

The following is the transcript of the Fairchild A-100A cockpit voice recorder serial number 53282, installed on American Airlines flight 1420, a McDonnell Douglas MD-82, N215AA, that overran the end of the runway at Little Rock National Airport, on June 1, 1999.

LEGEND

RDO	Radio transmission from accident aircraft
CAM	Cockpit area microphone voice or sound source
PA	PA voice transmitted over aircraft public address system
INT	Voice transmitted over aircraft interphone system
CTR	Radio transmission from Little Rock center controller
APR	Radio transmission from the Little Rock approach/tower controller
-1	Voice identified as Pilot-in-Command (PIC)
-2	Voice identified as Co-Pilot (SIC)
-3	Voice identified as 1 st female flight attendant
-4	Voice identified as 2 nd female flight attendant
-5	Voice identified as aircraft mechanical voice
-?	Voice unidentified
*	Unintelligible word
@	Non-pertinent word
#	Expletive
- - -	Break in continuity
()	Questionable insertion
[]	Editorial insertion
.....	Pause

Note 1: Times are expressed in central daylight time (CDT).

Note 2: Generally only radio transmissions to and from the accident aircraft were transcribed.

Note 3: Words shown with excess vowels, letters, or drawn out syllables are a phonetic representation of the words as spoken.

INTRA-COCKPIT COMMUNICATION		AIR-GROUND COMMUNICATION	
TIME & SOURCE	CONTENT	TIME & SOURCE	CONTENT
1119:44	START of RECORDING START of TRANSCRIPT		
1119:53 CAM-2	I warmed it up pretty good.		
1119:55 CAM-1	aah.		
1119:56 CAM-2	like it. **		
1119:56 CAM-1	actually, it's getting pretty hot.		
1120:07 CAM-2	did they complain about the temperature?		
1120:09 CAM-1	naw, it's getting warm up here.		
1120:11 CAM-2	ah, okay.	1120:15 CTR	American fourteen twenty, are you gonna want still want lower?
1120:18 CAM-1	ah, so far it's okay.	1120:20 RDO-2	so far so good ma'am. fourteen twenty we'll let you know.
		1120:24 CTR	right.

AIR-GROUND COMMUNICATION

INTRA-COCKPIT COMMUNICATION

TIME & SOURCE	CONTENT	TIME & SOURCE	CONTENT
1120:52 CAM-2	twenty five for twenty four. set and armed.		
1121:01 CAM-2	this stuff is working out pretty well. * get ahead of that stuff.		
1121:45 CAM-1	** , we're almost down to max landing weight.		
1121:55 CAM-1	we'll be there.		
1121:57 CAM-2	yeah.		
1122:17 CAM-2	you want to use one thirty, right?		
1122:19 CAM-1	yeah, well. I don't know. we've got a hundred miles to go. yeah, I guess so.		
1122:32 CAM-1	and we'll use flaps forty since **.		
1122:35 CAM-2	sure.		
1122:47 CAM-?	**.		
1122:50 CAM-?	**.		
1123:02 CAM-1	we're right on the edge of this **.		

AIR-GROUND COMMUNICATION

INTRA-COCKPIT COMMUNICATION

TIME & SOURCE	CONTENT	TIME & SOURCE	CONTENT
1123:24 CAM-?	**		
1123:58 CAM-2	this is the ground over here on the right.		
1124:00 CAM-1	yeah I see an occasional ground **.		
1124:13 CAM-?	[sound of yawn]		
1124:24 CAM-1	boy, this is too much (return).		
1124:44 CAM	[sound of "ding dong" similar to flight attendant call chime]		
1124:47 CAM-2	there's a moon out there. or a space ship.		
1124:53 CAM-1	yeah. the mother ship.		
1124:56 CAM-2	[sound of chuckle] got your Nike's on?		
1125:00 CAM-1	yeah, right.		
1125:01 CAM-?	[sound of chuckle]		
1125:03 CAM-1	what was that guy's name?		
1125:04 CAM-2	@, @ or.		

INTRA-COCKPIT COMMUNICATION		AIR-GROUND COMMUNICATION	
TIME & SOURCE	CONTENT	TIME & SOURCE	CONTENT
1125:06 CAM-1	yeah @.		
1125:10 CAM-2	center pumps comin' off.		
1125:11 CAM-1	all right.		
1125:12 CAM	[sound of two clicks]		
1125:17 CAM-2	there's your big waddidly.		
1125:19 CAM-1	yeah.		
1125:23 CAM-2	thirteen miles?		
1125:25 CAM-?	***.		
1125:30 CAM	[sound similar to ice bag being struck in galley]		
1125:47 CAM-1	we got to get over there quick.		
1125:52 CAM-2	I don't like that.... that's lightning.		
1126:00 CAM-1	sure is.		

AIR-GROUND COMMUNICATION

INTRA-COCKPIT COMMUNICATION

TIME & SOURCE	CONTENT	TIME & SOURCE	CONTENT
1126:24 CAM-2	oh.		
1126:40 CAM-1	that's about as far as we can go.		
1126:41 CAM-2	yeah, I would say right about. maybe a little bit more and that's about it. we could start down here pretty soon.		
1126:49 CAM-1	I'm gonna ask her to come **		
1126:52 CAM-1	this is the bowling alley right here.		
1126:54 CAM-2	yeah, I know.		
1126:59 CAM-1	in fact those are the city lights straight out there.		
1127:01 CAM-2	that's it.		
1127:07 CAM-2	want to go down?		
1127:09 CAM-1	uuh, not just yet.... but, pretty soon.		
1127:14 CAM-1	(seventy two), yeah.		
1127:15 CAM-?	**		

INTRA-COCKPIT COMMUNICATION		AIR-GROUND COMMUNICATION	
TIME & SOURCE	CONTENT	TIME & SOURCE	CONTENT
1127:27 CAM-1	ten set and armed.	1127:15 CTR	American fourteen twenty descend and maintain one zero thousand. the, Little Rock altimeter, is two niner eight six.
1127:28 CAM-2	thanks.	1127:24 RDO-2	ten thousand, two niner eight six. American fourteen twenty, thanks.
1127:31 PA-1	uh, we're now just uh, eighty miles from the airport and we have started our descent uh, toward it. quite a light show off the left hand side of the aircraft. we'll be passing that on our way toward Little Rock... and we should be landing here in about uh, probably about twenty minutes. I'm gonna have to slightly over-fly the airport, in or... order to turn back around to land. it's been a pleasure having you on board for this short flight and I'd like to take this opportunity to thank you for flying American Airlines.	1128:23 CTR	American fourteen twenty contact Memphis center one three five point eight. good day.
1128:06 CAM-2	descent checks are complete.	1128:27 RDO-2	thirty five eight, American fourteen twenty, good night.
1128:08 CAM-1	okay.		

INTRA-COCKPIT COMMUNICATION		AIR-GROUND COMMUNICATION	
TIME & SOURCE	CONTENT	TIME & SOURCE	CONTENT
1128:30 CAM-1	we gotta get there quick.		
1128:31 CAM-2	yep.		
		1128:44 RDO-2	American fourteen twenty leaving two two zero for one zero thousand.
		1128:51 CTR	Amer.... fourteen twenty, Memphis rog....
1129:02 CAM-2	sit'em down early?		
1129:03 CAM	[sound of "ding dong, ding dong" similar to flight attendant call chime]		
1129:06 INT-3	this is Nancy.		
1129:07 INT-1	yeah, how you guys uh, doing back there?		
1129:08 INT-4	this is Jennifer.		
1129:09 INT-1	yeah, how you guys doing back there?		
1129:10 INT-4	um, pretty okay.		
1129:11 INT-3	they're still out in the in the aisle with the cart doing the service.		

AIR-GROUND COMMUNICATION

INTRA-COCKPIT COMMUNICATION

TIME & SOURCE	CONTENT	TIME & SOURCE	CONTENT
1129:14 INT-4	yeah.		
1129:14 INT-1	really uh....		
1129:15 INT-3	yeah.		
1129:15 INT-1	it's uh, I think it's gonna get a little bumpy here again and if you don't mind uh....		
1129:18 INT-4	do we need to sit down?		
1129:19 INT-1	yeah, how far through are you?		
1129:21 INT-4	we're almost done but not quite, so....		
1129:23 INT-1	okay, well, finish it real quick.		
1129:24 INT-4	okay.		
1129:25 INT-1	all right.		
1129:25 INT-4	'bye.		
1129:26 INT-1	'bye.		

INTRA-COCKPIT COMMUNICATION		AIR-GROUND COMMUNICATION	
TIME & SOURCE	CONTENT	TIME & SOURCE	CONTENT
1129:47 CAM-2	yeah, that alley's getting' big.... closing to the west.	1129:35 CTR	American fourteen twenty, roger. Little Rock altimeter's two niner eight six.
1129:51 CAM-1	yeah it is.	1129:40 RDO-2	two niner eight six, American fourteen twenty.
1129:52 CAM-2	* be okay.		
1129:55 CAM-2	I say we get down as soon as we can.		
1129:59 CAM-1	two nine eight six?		
1130:00 CAM-2	* nine eight six. altimeters are set and cross checked.		
1130:09 CAM-2	aw #, no right side **.		
1130:52 CAM-2	okay, hydraulic pumps are on, high, and on.		
1130:55 CAM-1	okay.		
1130:55 CAM-2	altimeters? two nine eight six.		

AIR-GROUND COMMUNICATION

INTRA-COCKPIT COMMUNICATION

TIME & SOURCE	CONTENT	TIME & SOURCE	CONTENT
1130:59 CAM-1	reset, two nine eight six.		
1131:00 CAM-2	flight instruments and bugs?		
1131:02 CAM-1	uuh, I got a hundred, and thirty.		
1131:06 CAM-2	yeah.		
1131:08 CAM-1	with the flaps forty, a hundred and thirty thousand pounds. four hundred and sixty feet, two hundred feet ***		
1131:16 CAM-2	set and cross checked.		
1131:18 CAM-2	tail de-ice? uh, not required?		
1131:21 CAM-1	uh, not required.		
1131:22 CAM-2	manual brakes?		
1131:24 CAM-1	uuh, manual's fine.		
1131:32 CAM-1	I have to go a little to the right here.		
1131:33 CAM-2	yeah.		

AIR-GROUND COMMUNICATION

INTRA-COCKPIT COMMUNICATION

TIME & SOURCE	CONTENT	TIME & SOURCE	CONTENT
1131:34 CAM-?	(don't turn left)		
1131:38 CAM-2	actually there's the city right there.		
1131:39 CAM-1	yeah.		
1131:42 CAM-2	breaking out of this (crud). good.... doing good.		
1131:55 CAM-2	whoa. looks like it's movin' this way though.		
1131:57 CAM-1	yeah *.		
1131:58 CAM-2	***.		
1132:08 CAM-1	* just some lightning straight ahead.		
1132:14 CAM-2	*** think we're gonna be okay. right there.		
1132:18 CAM-?	*.		
1132:31 CAM-1	down the bowling alley.		
1132:47 CAM-2	as my friends would say, California cool.		
1132:51 CAM-1	cool.		

INTRA-COCKPIT COMMUNICATION		AIR-GROUND COMMUNICATION	
TIME & SOURCE	CONTENT	TIME & SOURCE	CONTENT
1132:52 CAM-2	[sound of chuckle]		
1132:54 CAM-1	peachy.		
1132:55 CAM-2	exactly.		
1133:48 CAM-1	that's forty miles.	1133:49 CTR	American fourteen twenty, contact Little Rock approach one three five point four.
1133:50 CAM-2	yeah.	1133:55 RDO-2	thirty five four, American fourteen twenty. you have a good night.
		1133:57 CTR	good night.
		1134:05 RDO-2	American uh, fourteen twenty at uh, eleven three for ten thousand.
		1134:11 APR	American fourteen twenty, Little Rock approach roger. ah we have a thunderstorm just northwest of the airport moving uh, through the area now. wind is two eight zero at two eight, gusts four four and uh, I'll have new weather for you in just a moment I'm sure.

INTRA-COCKPIT COMMUNICATION		AIR-GROUND COMMUNICATION	
TIME & SOURCE	CONTENT	TIME & SOURCE	CONTENT
1134:34 CAM-1	all right two eight zero at four four.	1134:23 RDO-2	yeah we can see the uh, lightning and uh, you wanta repeat those winds again.
1134:36 CAM-2	gusts to forty four *.	1134:28 APR	right now the wind current wind is two niner zero at two eight, gusts four four.
1134:38 CAM-1	right near the limit.		
1134:39 CAM-2	yeah, it's uh, forty degrees off. what's our cross(wind) *.	1134:43 APR	American fourteen twenty expect an ILS runway two two left.
1134:46 CAM-1	thirty.	1134:47 RDO-2	two two left, we've got that, fourteen twenty.
1134:50 CAM-2	no that's that's *, you're, not out of the limits because of the angle *, but it's pretty close.		
1134:56 CAM-1	yeah.		
1135:21 CAM-2	two two left is the right one.... so uh....		

INTRA-COCKPIT COMMUNICATION		AIR-GROUND COMMUNICATION	
TIME & SOURCE	CONTENT	TIME & SOURCE	CONTENT
1135:29 CAM-2	I uh, I didn't realize that.		
1135:32 CAM-?	eerrraaw.		
		1135:37 APR	American fourteen twenty, descend at pilot's discretion. main-tain four thousand.
		1135:40 RDO-2	* down to four thousand, American uh, fourteen twenty.
1135:46 CAM-1	four thousand set.		
1135:50 CAM-2	okay, ten thousand foot, seatbelt sign no smoking.		
1135:52 CAM	[sound of "ding dong" similar to flight attendant call chime]		
1135:53 CAM-1	yeah I'll get down in a second *.		
1135:55 CAM-2	okay.		
1136:02 CAM-2	yeah it's ten knots uh....		
1136:04 CAM-1	thirty knots is the crosswind limitation but....		
1136:06 CAM-1	thirty knots is the.... wet, well.		

INTRA-COCKPIT COMMUNICATION		AIR-GROUND COMMUNICATION	
TIME & SOURCE	CONTENT	TIME & SOURCE	CONTENT
1136:08 CAM-2	that's the dry.		
1136:09 CAM-1	yeah, dry.		
1136:10 CAM-2	what about wet?		
1136:11 CAM-1	wet.		
1136:12 CAM-2	yeah.		
1136:12 CAM-1	is twenty.		
1136:13 CAM-2	ah, it's twenty five. aw, what the #.		
1136:30 PA-1	flight attendants prepare for landing please.		
1136:40 CAM-2	you got the NOTAMS, with ya?		
1137:17 CAM-2	see the airport?		
1137:18 CAM-1	see it blinking out there.		
1137:20 CAM-2	** to the north,		
1137:20 CAM-1	straight ahead.		

AIR-GROUND COMMUNICATION

INTRA-COCKPIT COMMUNICATION

TIME & SOURCE	CONTENT	TIME & SOURCE	CONTENT
1137:21 CAM-2	well there's a couple runways here so, the problem is we're sixteen miles south of the VOR and the airport's another five miles past that.		
1137:29 CAM-1	all right. (doesn't) matter.		
1137:32 CAM-2	so we've still got a little ways to go.... bad part..... I'll tell you what. I'm gonna stay on the run.... the VOR till we get a little closer.		
1138:22 CAM-1	oh I think I see, I see where it is.		
1138:25 CAM-2	yeah it's on **.		
1138:26 CAM-1	it's straight up there, yeah....		
1138:27 CAM-2	* (blinking) *.		
1138:28 CAM-1	it looks like there's stratus a layer, right over there.		
1138:36 CAM-2	*** I definitely got **. (I'll show you this later).		
1138:54 CAM-1	he said there was a storm just northwest of the field?		
1138:56 CAM-2	he said northwest.		

INTRA-COCKPIT COMMUNICATION		AIR-GROUND COMMUNICATION	
TIME & SOURCE	CONTENT	TIME & SOURCE	CONTENT
1138:57 CAM-1	yeah.		
1138:58 CAM-2	lightning strike he said storm, uh.	1139:00 APR	American fourteen twenty, descend and maintain, three thousand.
		1139:03 RDO-2	out of four for three, American uh, fourteen twenty.
		1139:06 APR	American fourteen twenty uh, you're equipment's a lot better than uh, what I have. how 's the final for two two left lookin'?
1139:12 CAM-1	what's that?	1139:12 RDO-2	okay, we can uh, see the airport from here. we can barely make it out but uh, we should be able to make two two. uh, that storm is moving this way like your, radar says it is but a little bit farther off than you thought.
		1139:23 APR	American fourteen twenty roger, would you just want to shoot a visual approach?
1139:27 CAM-1	naw.	1139:28 RDO-2	uh, at this point we can't really make it out. we're gonna have to stay with you as long as possible.

INTRA-COCKPIT COMMUNICATION		AIR-GROUND COMMUNICATION	
TIME & SOURCE	CONTENT	TIME & SOURCE	CONTENT
1139:38 CAM-1	whoa.	1139:32 APR	American fourteen twenty roger. and uh, the winds kinda kicked around a little bit right now. it's three three zero, at uh, one one.
1139:42 CAM-1	* thirty is a, tailwind though.	1139:39 RDO-2	okay, well that's a little bit, better than it was.
1139:53 CAM-?	*	1139:45 APR	*
1139:56 CAM-1	** be landing on four?	1139:45 APR	and uh, right now I have a uh, windshear alert. the center field wind is three four zero at one zero north boundary wind is three three zero at two five. northwest boundary wind is zero one zero at one five.
1140:05 CAM-1	it'd be a headwind.	1139:59 RDO-2	is there a possibility to get runway four?
		1140:01 APR	American fourteen twenty yes sir. we can do runway four if * you'd prefer that.

INTRA-COCKPIT COMMUNICATION		AIR-GROUND COMMUNICATION	
TIME & SOURCE	CONTENT	TIME & SOURCE	CONTENT
1140:06 CAM-2	yeah.		
1140:06 CAM-2	I think we're gonna need....	1140:08 RDO-2	...we would rather do the headwinds sir.
		1140:09 APR	I'm sorry, say again American fourteen twenty.
		1140:12 RDO-2	yeah, we're gonna want the headwind of course.... runway four.
1140:19 CAM-1	we're going to three, right?	1140:20 APR	American uh, fourteen twenty uh, turn right heading of uh, two five zero vectors for the ILS runway four right final approach course.
1140:22 CAM-2	yeah, three thousand.	1140:26 RDO-2	okay, a right turn to two five zero uh, the long way around?
		1140:29 APR	uh, yes sir, you're a little close to the airport.
1140:31 CAM-1	yeah right.		

INTRA-COCKPIT COMMUNICATION		AIR-GROUND COMMUNICATION	
TIME & SOURCE	CONTENT	TIME & SOURCE	CONTENT
1140:36 CAM-2	* , runway four.	1140:32 RDO-2	two five zero, that'll work.
1140:46 CAM-2	four right. one one point three.... zero four two. I think we were, I think that was the airport right below us.		
1141:02 CAM-1	yeah it was. okay, one eleven three.		
1141:07 CAM-2	one eleven three. zero four two. four sixty on decision altitude.		
1141:14 CAM-2	four thousand for three thousand, is armed.		
1141:16 CAM-1	okay.		
1141:19 CAM-2	uh, MSA is thirty three hundred feet all the way around.	1141:22 APR	American fourteen twenty uh, maintain three thousand three hundred for now please.
1141:28 CAM-1	yeah, the uh *.	1141:25 RDO-2	three thousand three hundred. we just saw it, thanks.

AIR-GROUND COMMUNICATION

INTRA-COCKPIT COMMUNICATION

TIME & SOURCE	CONTENT	TIME & SOURCE	CONTENT
1141:31 CAM-2	okay. and two two seventeen glide slope intercept all the way down missed approach right turn to four thousand.... ***		
1141:57 CAM-2	let's see, you got the airport? tell you what. *		
1142:00 CAM-1	yeah. ** I don't have the airport.		
1142:03 CAM-2	** , I'm saying you got the ILS.		
1142:04 CAM-1	yeah, I got the ILS		
1142:07 CAM-1	it's uh....		
1142:13 CAM-2	yeah, there it is. I got the airport.		
1142:16 CAM-1	okay, and decision height is four sixty.		
1142:17 CAM-2	yeah.		
1142:19 CAM-1	do you have the airport?		
1142:20 CAM-2	*		
1142:20 CAM-1	is that it right there?		

INTRA-COCKPIT COMMUNICATION		AIR-GROUND COMMUNICATION	
TIME & SOURCE	CONTENT	TIME & SOURCE	CONTENT
1142:21 CAM-?	okay.		
1142:23 CAM-2	* see, I can't.		
1142:24 CAM-1	I don't see a runway.		
1142:26 CAM-2	go out this way.		
		1142:27 APR	American fourteen twenty, it appears we have uh, second part of this storm moving through. the winds now, three four zero at one six, gusts three four.
1142:34 CAM-1	okay.		
		1142:35 RDO-2	roger that.
1142:40 CAM-2	you wanna accept a short approach? want to keep it in tight?		
1142:42 CAM-1	yeah, if you see the runway. 'cause I don't quite see it.		
1142:45 CAM-2	yeah, it's right here, see it?		
1142:48 CAM-1	[sound of grunt] you just point me in the right direction and I'll start slowing down here. give me flaps eleven.		

INTRA-COCKPIT COMMUNICATION		AIR-GROUND COMMUNICATION	
TIME & SOURCE	CONTENT	TIME & SOURCE	CONTENT
1142:55 CAM-2	#, it's going right over the.... f-field.	1142:54 RDO-2	and uh....
1142:55 CAM-1	*	1142:56 APR	American fourteen twenty, did you call me?
		1142:59 RDO-2	well we got the airport. we're going between clouds. I think it's right off my uh, three o'clock low, about four miles.
		1143:05 APR	American fourteen twenty, that's it. do you wanna shoot the visual approach or you wanna go out for the ILS?
		1143:09 RDO-2	I can, we'll, we'll (start) the visual. if we we can do it.
		1143:11 APR	American fourteen twenty's cleared visual approach runway four right. if you lose it, need some help. let me know please.
		1143:15 RDO-2	I'll stay with you as long as possible, OK?
		1143:18 APR	that's fine, I'm working everything, American fourteen twenty.

INTRA-COCKPIT COMMUNICATION		AIR-GROUND COMMUNICATION	
TIME & SOURCE	CONTENT	TIME & SOURCE	CONTENT
1143:23 CAM-1	well you keep me straight.	1143:20 RDO-2	that works for me.
1143:23 CAM-2	keep it right here, keep it right here, ** right here.	1143:21 APR	all right.
1143:25 CAM-1	what?		
1143:26 CAM-2	okay, did you notice something? there's the airport right there. okay?		
1143:31 CAM-1	where?		
1143:31 CAM-2	okay, you're set up on a base for it. okay?		
1143:33 CAM-1	I'm on a base now?		
1143:35 CAM-2	well, you're on a dogleg, you're comin' in. there's the airport.		
1143:38 CAM-1	uh, I lost it.		
1143:39 CAM-2	right there, you're you're downwind. see it's right there.		

INTRA-COCKPIT COMMUNICATION		AIR-GROUND COMMUNICATION	
TIME & SOURCE	CONTENT	TIME & SOURCE	CONTENT
1143:44 CAM-1	I still don't see it. [sound of chuckle] well just vector me. I don't know.		
1143:47 CAM-2	okay, well just go * right here.		
1143:49 CAM-1	okay.	1143:59 APR	American fourteen twenty, you can monitor one one eight point seven, runway four right, cleared to land. the wind right now three three zero at two one.
1144:10 CAM-1	*****.	1144:05 RDO-2	eighteen seven, we'll monitor, American fourteen twenty, thanks. cleared to land runway four.
1144:13 CAM-2	if you look at		
1144:14 CAM-1	those red lights out there. where, where's that in relation to....		
1144:18 CAM-2	there's another, there's two runways here. there's three runways.		
1144:19 CAM-1	yeah I know. see we're losing it. I don't think we can maintain visual.		
1144:22 CAM-2	** yeah.		

INTRA-COCKPIT COMMUNICATION		AIR-GROUND COMMUNICATION	
TIME & SOURCE	CONTENT	TIME & SOURCE	CONTENT
1144:26 CAM-1	oh, you're on tower.	1144:23 RDO-2	hold on and uh.....
1144:27 CAM-2	oh, I'm sorry.	1144:28 RDO-2	and approach American fourteen twenty.
		1144:29 APR	American fourteen twenty, yes sir.
		1144:30 RDO-2	and there's a cloud between us and the airport. we just lost the field and I'm uh, on this vector here, I have the uh, basically last vector you gave us, we're on kind of a dog leg it looks like.
		1144:39 APR	American fourteen twenty, can you fly heading two two zero? I'll take you out for the ILS.
1144:42 CAM-1	**.	1144:43 RDO-2	yeah two two zero's fine.
		1144:45 APR	and it will be just one probably one turn on from uh, downwind to final, for the ILS.

INTRA-COCKPIT COMMUNICATION		AIR-GROUND COMMUNICATION	
TIME & SOURCE	CONTENT	TIME & SOURCE	CONTENT
1144:51 CAM-2	yeah, I had it but I lost it with the clouds and that's what I was saying.	1144:49 RDO-2	"K that's how it's gonna have to be, thanks.
1144:54 CAM-1	okay.	1144:54 APR	American fourteen twenty, descend and maintain two thousand three hundred.
1144:59 CAM-2	two thousand three hundred.	1144:56 RDO-2	two thousand three hundred, American fourteen twenty.
1145:00 CAM-1	set and armed. uh, now it is.		
1145:07 CAM-2	#, * we had it.		
1145:09 CAM-1	yeah. I just, I never saw the runway.		
1145:11 CAM-2	no no, it's okay. I**.		
1145:12 CAM	[sound similar to stabilizer-in-motion horn]		
1145:13 CAM-5	stabilizer motion		

INTRA-COCKPIT COMMUNICATION		AIR-GROUND COMMUNICATION	
TIME & SOURCE	CONTENT	TIME & SOURCE	CONTENT
1145:15 CAM-1	I hate droning around visual at night in weather without, having some clue where I am.		
1145:23 CAM-2	yeah but, the longer we go out here the....		
1145:24 CAM-1	yeah, I know.		
1145:25 CAM	[sound similar to stabilizer-in-motion horn]		
1145:26 CAM-5	stabilizer motion.		
1145:29 CAM-2	see how we're going right into this crap.		
1145:31 CAM-1	right.	1145:47 RDO-2	and approach American fourteen twenty, I know you're doing your best sir. we're getting pretty close to this storm. we'll keep it tight if we have to.
		1145:52 APR	* American fourteen twenty uh, turn right heading of uh, two seven zero.
1145:56 CAM	[sound similar to stabilizer-in-motion horn]	1145:57 RDO-2	two seven zero, American fourteen twenty.

INTRA-COCKPIT COMMUNICATION		AIR-GROUND COMMUNICATION	
TIME & SOURCE	CONTENT	TIME & SOURCE	CONTENT
1146:04 CAM-1	that's great.	1145:59 APR	and uh, when you join the final, you're going to be right at just a little bit outside the marker if that's gonna be okay for ya.
1146:11 CAM	[sound similar to stabilizer-in-motion horn]	1146:05 RDO-2	that's great with us.
1146:11 CAM-2	see we're right on the base of these clouds so....	1146:06 APR	American fourteen twenty, roger.
1146:13 CAM-1	yeah.		
1146:14 CAM-2	... it's not worth it.		
1146:15 CAM	[sound similar to stabilizer-in-motion horn]		
1146:20 CAM-2	two seven zero, two thousand three hundred?		
1146:23 CAM-1	yes sir. * where I am.	1146:25 APR	American fourteen twenty, turn right heading three, zero zero.

INTRA-COCKPIT COMMUNICATION		AIR-GROUND COMMUNICATION	
TIME & SOURCE	CONTENT	TIME & SOURCE	CONTENT
1146:43 CAM	[brief sound of Morse Code identifier]	1146:29 RDO-2	right turn three zero zero American fourteen twenty.
1146:52 CAM-1	aw, we're goin' right into this.	1146:39 APR	American fourteen twenty is uh, three miles from the marker. turn right heading zero two zero. maintain two thousand three hundred 'til established on the localizer. cleared ILS runway four right approach.
1146:53 CAM	[sound similar to stabilizer-in-motion horn]	1146:47 RDO-2	zero two zero 'til established. American fourteen twenty, cleared four left approach.
1147:04 CAM-1	three thousand.	1146:52 APR	American fourteen twenty, right now we have uh, heavy rain on the airport. the uh, current weather on the ATIS is not correct. I don't have new weather for ya, but the uh, visibility is uh, less than a mile. runway four right RVR is three thousand.
1147:07 CAM	[sound similar to stabilizer-in-motion horn]	1147:04 RDO-2	roger that, three thousand, American uh, fourteen twenty. this is four right, correct?

INTRA-COCKPIT COMMUNICATION		AIR-GROUND COMMUNICATION	
TIME & SOURCE	CONTENT	TIME & SOURCE	CONTENT
1147:10 CAM-1	can we land?	1147:08 APR	American fourteen twenty, that's correct sir. and runway four right, cleared to land. the wind three five zero at three zero, gusts four five.
1147:19 CAM-2	** zero forecast right down the runway.	1147:16 RDO-2	zero three zero at four five, American fourteen twenty.
1147:22 CAM-1	three thousand RVR. we can't land on that.		
1147:24 CAM-2	three thousand if you look at uh....		
1147:26 CAM	[sound similar to stabilizer-in-motion horn]		
1147:27 CAM-1	what do we need?		
1147:28 CAM-2	no it's twenty four hundred RVR.		
1147:29 CAM-1	okay, fine.		
1147:30 CAM-2	yeah, we're doing fine.		
1147:31 CAM-1	all right.		

INTRA-COCKPIT COMMUNICATION		AIR-GROUND COMMUNICATION	
TIME & SOURCE	CONTENT	TIME & SOURCE	CONTENT
1147:34 CAM-1	uh, fifteen.		
1147:36 CAM	[sound of clicks similar to flap handle movement]		
1147:40 CAM	[sound similar to stabilizer-in-motion horn]		
1147:44 CAM-1	llanding gear down.		
1147:46 CAM	[sound similar to landing gear being operated]		
1147:47 CAM	[sound similar to stabilizer-in-motion horn]		
1147:49 CAM-1	and lights ** please.		
1147:51 CAM	[sound similar to stabilizer-in-motion horn]		
1147:52 CAM-5	stabilizer motion	1147:53 APR	windshear alert, center field wind, three five zero at three two, gusts four five. north boundary wind three one zero at two niner. northeast boundary wind three two zero at three two.
1148:01 CAM	[sound similar to stabilizer-in-motion horn]		
1148:02 CAM-5	stabilizer motion.		

INTRA-COCKPIT COMMUNICATION		AIR-GROUND COMMUNICATION	
TIME & SOURCE	CONTENT	TIME & SOURCE	CONTENT
1148:03 CAM-2	flaps twenty eight?		
1148:10 CAM-1	add twenty.		
1148:12 CAM-2	right.		
1148:12 CAM-1	add twenty knots.	1148:12 APR	American fourteen twenty, the runway four right RVR now is one thousand six hundred.
1148:14 CAM-2	okay.		
1148:17 CAM-2	aw #.		
1148:18 CAM-1	well we're established on the final.		
1148:20 CAM-2	we're established we're inbound, right.	1148:24 RDO-2	okay, American fourteen twenty, we're established inbound.
		1148:26 APR	American fourteen twenty roger, runway four right, cleared to land, and the wind, three four zero at three one. north wind, north uh, boundary wind is three zero zero at two six, north-east boundary wind three two zero at two five, and the four right RVR is one thousand six hundred.

INTRA-COCKPIT COMMUNICATION		AIR-GROUND COMMUNICATION	
TIME & SOURCE	CONTENT	TIME & SOURCE	CONTENT
1148:36 CAM	[sound similar to stabilizer-in-motion horn]		
1148:43 CAM-2	that's a good point.	1148:41 RDO-2	American uh, fourteen twenty, thanks.
1148:45 CAM	[unidentified intermittent tone]		
1148:47 CAM-2	keep the speed.		
1148:50 CAM-2	thousand feet.		
1148:54 CAM-1	I don't see anything. lookin' for four sixty.		
1148:58 CAM	[sound similar to stabilizer-in-motion horn]		
1149:00 CAM-2	it's there.		
1149:02 CAM-2	want forty flaps?		
1149:04 CAM-1	oh yeah, thought I called it.		
1149:05 CAM-2	forty now. thousand feet. twenty, forty forty land.		
1149:10 CAM	[unidentified tone similar to sound at time 1148:45]		

INTRA-COCKPIT COMMUNICATION		AIR-GROUND COMMUNICATION	
TIME & SOURCE	CONTENT	TIME & SOURCE	CONTENT
1149:12 CAM-1	this is, this is a can of worms.	1149:10 APR	wind is three three zero at two eight.
1149:17 CAM	[sound similar to stabilizer-in-motion horn]		
1149:22 CAM	[sound similar to stabilizer-in-motion horn]		
1149:24 CAM-1	(I'm gonna stay above it a little)		
1149:24 CAM-2	there's the runway off to your right, got it?		
1149:26 CAM-1	no.		
1149:27 CAM-2	I got the right runway in sight.		
1149:30 CAM-2	you're right on course. stay where you're at.		
1149:31 CAM-1	I got it, I got it.	1149:32 APR	wind three three zero at two five.
1149:37.7 CAM-?	wipers.		

INTRA-COCKPIT COMMUNICATION		AIR-GROUND COMMUNICATION	
TIME & SOURCE	CONTENT	TIME & SOURCE	CONTENT
1149:41.4 CAM	[sound similar to windshield wiper motion]		
1149:46.4 CAM-2	five hundred feet.		
1149:50.1 CAM-?	*		
1149:53.7 CAM-1	plus twenty.	1149:53.1 APR	wind three two zero, at two three.
1149:56.6 CAM-?	aw #, we're off course.		
1149:57.6 CAM-?	**		
1150:00.4 CAM-2	we're way off.		
1150:01.5 CAM-1	I can't see it.		
1150:04.4 CAM-2	got it?		
1150:05.1 CAM-1	yeah I got it.		
1150:07.9 CAM-2	hundred feet.		
1150:09.4 CAM-?	above.		

INTRA-COCKPIT COMMUNICATION		AIR-GROUND COMMUNICATION	
TIME & SOURCE	CONTENT	TIME & SOURCE	CONTENT
1150:11.1 CAM-2	hundred.		
1150:12.8 CAM-5	sink rate.		
1150:13.7 CAM-2	fifty.		
1150:14.2 CAM-5	sink rate.		
1150:14.5 CAM-2	forty.		
1150:15.8 CAM-2	thirty.		
1150:17.6 CAM-2	twenty.		
1150:18.3 CAM-2	ten.		
1150:20.2 CAM	[sound of two thuds similar to aircraft touching down on runway concurrent with unidentified squeak sound]		
1150:22.2 CAM-2	we're down.		
1150:24.4 CAM-2	we're sliding.		
1150:26.1 CAM-1	#.... #.		

INTRA-COCKPIT COMMUNICATION		AIR-GROUND COMMUNICATION	
TIME & SOURCE	CONTENT	TIME & SOURCE	CONTENT
1150:31.8 CAM-?	on the brakes.		
1150:33.1 CAM-?	oh sh		
1150:33.5 CAM	[sound similar to increase in engine RPM]		
1150:35.1 CAM-?	other one, other one, other one.		
1150:40.9 CAM-?	aw #.		
1150:41.6 CAM-?	##.		
1150:43.8 CAM	[sound of impact]		
1150:44.3 CAM-?	##.		
1150:46.9 CAM	[sound of several impacts]		
1150:48.1			
	END of RECORDING		
	END of TRANSCRIPT		

Appendix C

Automated Surface Observing System Data

Time	Wind information		Precipitation information	
	2 minute	5-second gust	1 minute	15 minute
2330	203° at 08 knots	244° at 09 knots	0.00 inch	Trace amount
2331	241° at 11 knots	274° at 20 knots	0.00 inch	
2332	273° at 19 knots	278° at 29 knots	0.00 inch	
2333	291° at 25 knots	295° at 35 knots	0.00 inch	
2334	298° at 27 knots	290° at 33 knots	Trace amount	
2335	298° at 26 knots	289° at 27 knots	Trace amount	
2336	289° at 21 knots	281° at 25 knots	0.01 inch	
2337	286° at 15 knots	285° at 18 knots	0.00 inch	
2338	304° at 17 knots	318° at 18 knots	0.01 inch	
2339	320° at 17 knots	336° at 20 knots	0.02 inch	
2340	320° at 17 knots	336° at 20 knots	0.01 inch	
2341	338° at 17 knots	333° at 22 knots	0.01 inch	
2342	351° at 18 knots	356° at 27 knots	0.01 inch	
2343	359° at 21 knots	360° at 28 knots	0.02 inch	
2344	352° at 20 knots	357° at 20 knots	0.02 inch	
2345	320° at 17 knots	336° at 20 knots	0.03 inch	0.14 inch
2346	322° at 14 knots	333° at 16 knots	0.03 inch	
2347	328° at 15 knots	329° at 26 knots	0.06 inch	
2348	314° at 14 knots	283° at 11 knots	0.07 inch	
2349	296° at 12 knots	291° at 20 knots	0.03 inch	
2350	285° at 16 knots	302° at 22 knots	0.04 inch	
2351	281° at 18 knots	291° at 21 knots	0.04 inch	

Time	Wind information		Precipitation information	
	2 minute	5-second gust	1 minute	15 minute
2352	284° at 19 knots	287° at 24 knots	0.06 inch	
2353	281° at 18 knots	287° at 21 knots	0.08 inch	
2354	277° at 14 knots	264° at 14 knots	0.13 inch	
2355	287° at 13 knots	296° at 18 knots	0.08 inch	
2356	299° at 23 knots	317° at 76 knots	0.15 inch	
2357	308° at 20 knots	281° at 16 knots	0.14 inch	
2358	291° at 10 knots	241° at 21 knots	0.11 inch	
2359	297° at 09 knots	012° at 08 knots	0.05 inch	
0000	358° at 09 knots	023° at 14 knots	0.02 inch	1.09 inches

Note: In the body of this report, wind directions were rounded to the nearest tenth.

NATIONAL TRANSPORTATION SAFETY BOARD
Washington, D.C. 20594

OFFICIAL BUSINESS
PENALTY FOR PRIVATE USE, \$300

PRSR STD
Postage & Fees Paid
NTSB
Permit No. G-200