

REPORT DOCUMENTATION PAGE

Form Approved
OMB No. 0704-0188

Public reporting burden for this collection of information is estimated to average 1 hour per response, including the time for reviewing instructions, searching existing data sources, gathering and maintaining the data needed, and completing and reviewing this collection of information. Send comments regarding this burden estimate or any other aspect of this collection of information, including suggestions for reducing this burden to Department of Defense, Washington Headquarters Services, Directorate for Information Operations and Reports (0704-0188), 1215 Jefferson Davis Highway, Suite 1204, Arlington, VA 22202-4302. Respondents should be aware that notwithstanding any other provision of law, no person shall be subject to any penalty for failing to comply with a collection of information if it does not display a currently valid OMB control number. **PLEASE DO NOT RETURN YOUR FORM TO THE ABOVE ADDRESS.**

1. REPORT DATE (DD-MM-YYYY) 13-01-1998	2. REPORT TYPE Paper	3. DATES COVERED (From - To)
--	--------------------------------	-------------------------------------

4. TITLE AND SUBTITLE A Free Molecule Micro-Resistojet: An Interesting Alternative to Nozzle Expansion	5a. CONTRACT NUMBER
	5b. GRANT NUMBER
	5c. PROGRAM ELEMENT NUMBER

6. AUTHOR(S) Andrew D. Ketsdever; Dean C. Wadsworth; Stephen Vargo; E.P. Muntz	5d. PROJECT NUMBER 2308
	5e. TASK NUMBER M19B
	5f. WORK UNIT NUMBER

7. PERFORMING ORGANIZATION NAME(S) AND ADDRESS(ES) AND ADDRESS(ES) Air Force Research Laboratory (AFMC) AFRL/PRS 5 Pollux Drive Edwards AFB CA 93524-7048	8. PERFORMING ORGANIZATION REPORT
--	--

9. SPONSORING / MONITORING AGENCY NAME(S) AND ADDRESS(ES) Air Force Research Laboratory (AFMC) AFRL/PRS 5 Pollux Drive Edwards AFB CA 93524-7048	10. SPONSOR/MONITOR'S ACRONYM(S)
	11. SPONSOR/MONITOR'S NUMBER(S) AFRL-PR-ED-TP-1998-016

12. DISTRIBUTION / AVAILABILITY STATEMENT
Approved for public release; distribution unlimited.

13. SUPPLEMENTARY NOTES

14. ABSTRACT

20020115 060

15. SUBJECT TERMS

16. SECURITY CLASSIFICATION OF:			17. LIMITATION OF ABSTRACT A	18. NUMBER OF PAGES	19a. NAME OF RESPONSIBLE PERSON Carl Ousley
a. REPORT Unclassified	b. ABSTRACT Unclassified	c. THIS PAGE Unclassified			19b. TELEPHONE NUMBER (include area code) (661) 275-6346

A Free Molecule Micro-Resistojet: An Interesting Alternative to Nozzle Expansion

Andrew D. Ketsdever[‡]
USAF Research Laboratory
Fundamental Technologies Division
Edwards AFB, CA 93524-7660

Dean C. Wadsworth[‡]
Hughes STX
Edwards AFB, CA 93524-7660

Stephen Vargo* and E.P. Muntz[†]
University of Southern California
Department of Aerospace Engineering
Los Angeles, CA 90089-1191

ABSTRACT

The growing trend of using significant numbers of small spacecraft, thus enhancing the performance of communication and surveillance tasks previously done by a few much larger vehicles, has created a requirement for low power, highly efficient propulsion systems.^{1,2} It is clear that this class of small satellites will require station keeping with low mass, low thrust, low impulse bit (I-bit) thrusters, orbital transfer and rendezvous capabilities, multiple orbital plane changes, and de-orbit provisions. Small satellites are not only mass limited but also seriously power limited. For the mass range below 50 kg, a figure of merit is 1 W/kg available for propulsion, although this could be increased during orbital transfer or plane change maneuvers. Small mass, power efficient thrusters (microthrusters) need to be developed.

There is a growing realization that in many cases microthrusters will not be simply scaled down versions of present thrusters. For example, chemical thrusters have difficulty maintaining efficiency at small scales due to increases in frozen flow and viscous losses. For ion electric propulsion, the increase in surface to volume ratio as the size decreases makes the scaling of these thrusters to small size, while maintaining efficiency, extremely difficult. In this paper, an electric thruster that is scalable to spacecraft in the kilogram to hundreds of kilogram range is discussed.

[‡] Research Engineer, AIAA Member

* Research Assistant, AIAA Student Member

† Professor, AIAA Fellow

The Free Molecule Micro-Resistojet (FMMR) satisfies the various issues resulting from extreme size reduction and appears to be scalable to rather large size without penalty. The FMMR is intended primarily for use as an attitude control thruster.

As shown by Muntz and Ketsdever³, there are only quite modest differences between the performance of a free molecule orifice expansion and limit isentropic expansion with respect to I_{sp} . If nozzle losses (viscous and radial flow) are taken into account, the differences between the free molecule expansion and the nozzle expansion would become even less pronounced. For a given stagnation temperature and propellant, nozzles are decreased in size to reduce thrust. In order to reduce the thrust by a factor of ten, but also maintain the same level of viscous losses as in some reference nozzle, the size must be reduced by a factor of 10^2 . Thus, a typical throat diameter might be 20 μm . The very small throat size accompanying efficient reduced thrust operation presents a single point failure possibility because of the potential for contaminants plugging the small throat. Also, high stagnation pressures require high pressure storage of propellant gas or higher temperature heating of a subliming solid or evaporating liquid.⁴

One way to avoid these issues is to operate the FMMR like the one shown in Figure 1. The free molecule condition requires that the slot width w be less than $1/4$ of a molecular mean free path in the stagnation chamber. The design requirement is to arrange that the last surface contact by a molecule before it exits through the slot is with a surface held at the required stagnation temperature. In order to demonstrate the flexibility of the FMMR, a design that satisfies the Δv and mass requirement for a hypothetical 0.33kg Earth observing satellite described by Janson⁵ is shown in Figure 2. This FMMR system has a wet mass of 0.02 kg, a thrust of 0.1 mN, a stagnation temperature of 1200 K and a stagnation pressure of 20 Pa. The design provides for a 10% thruster mass ratio and a Δv of 100 m/s.

An exhaustive examination of heat loss, surface effects and stagnation region configuration has begun using the Direct Simulation Monte Carlo (DSMC) technique.⁶ Figure 3 shows translational temperature contours for the FMMR configuration shown in Figure 1 for an argon gas flow with a stagnation temperature of 600 K. The slot width w is 100 μm for this calculation. Further results including calculated thrust and I_{sp} will be presented in the final manuscript.

The FMMR currently under consideration will provide nearly 1 mN of thrust and be roughly 1 cm^3 in size. This small thruster is composed of five separate parts in a stacked configuration. The construction and design of the FMMR is a product of well established microelectromechanical (MEMS) fabrication techniques. A sketch depicting the stacking order of these parts is shown in Figure 4. The first part is a 400 μm thick silicon wafer that has patterned slots which expand the working gas. The slots are 100 μm wide at their base, 8.7 mm long and are spaced 1 mm apart. The second part is a 100 μm thick silicon wafer that provides a nominal spacing between the thin-film heaters used to heat the gas and the slots. The third part is a 400 μm thick quartz wafer that supports the heaters and has passages for gas flow. Quartz is selected here for its low thermal conductivity (1.4 W / m \cdot K) and high operable temperature (1400 K) properties. Since the heaters provide a stagnation temperature of up to 1200 K this material needs to withstand the high temperatures of operation as well as not readily conduct heat to other parts. The fourth part is a 3 mm

thick quartz plenum section for the gas flow. The fifth part is a 3 mm thick quartz plate that has a 6 mm OD glass tube connected to it which functions as the gas feedthrough for the device. Adjacent parts in the stack will be wafer bonded to each other to ensure proper sealing.

References

1. M. Ruzicha, The Race to LEO, *Launchspace*, 32-34, Aug./Sept. 1997.
2. D. Dichmann, The Constellations in LEO, *Launchspace*, 40-41, Aug./Sept. 1997.
3. E.P. Muntz and A. Ketsdever, Microspacecraft Exhaust Plumes, Thrust Generation and Envelope Expansion to Lower Altitudes, presented at AFOSR Space Propulsion and Power Contractor's Meeting, San Diego, 28-31 July 1997.
4. J. Mueller, B. Tang, W. Li, I. Chakraborty, M. Parker, D. Barne, A. Wallace and R. Lawton, JPL's Micropropulsion Activities, presented at Micropropulsion Workshop, JPL, 7 April 1997.
5. S. Janson, Micropropulsion Activities at the Aerospace Corporation, presented at Micropropulsion Workshop, JPL, 7 April 1997.
6. G. Bird, Molecular Gas Dynamics and the Direct Simulation of Gas Flows, Oxford University Press, Oxford, 1994.

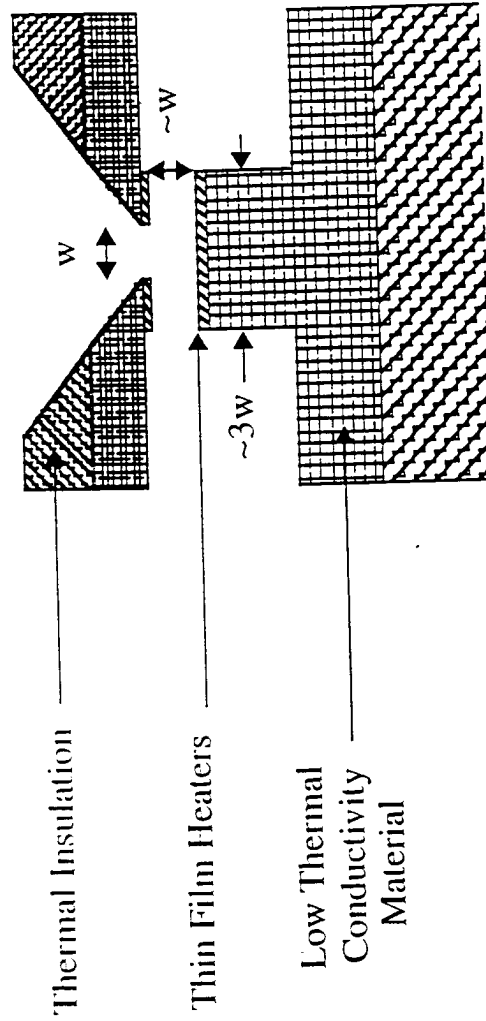
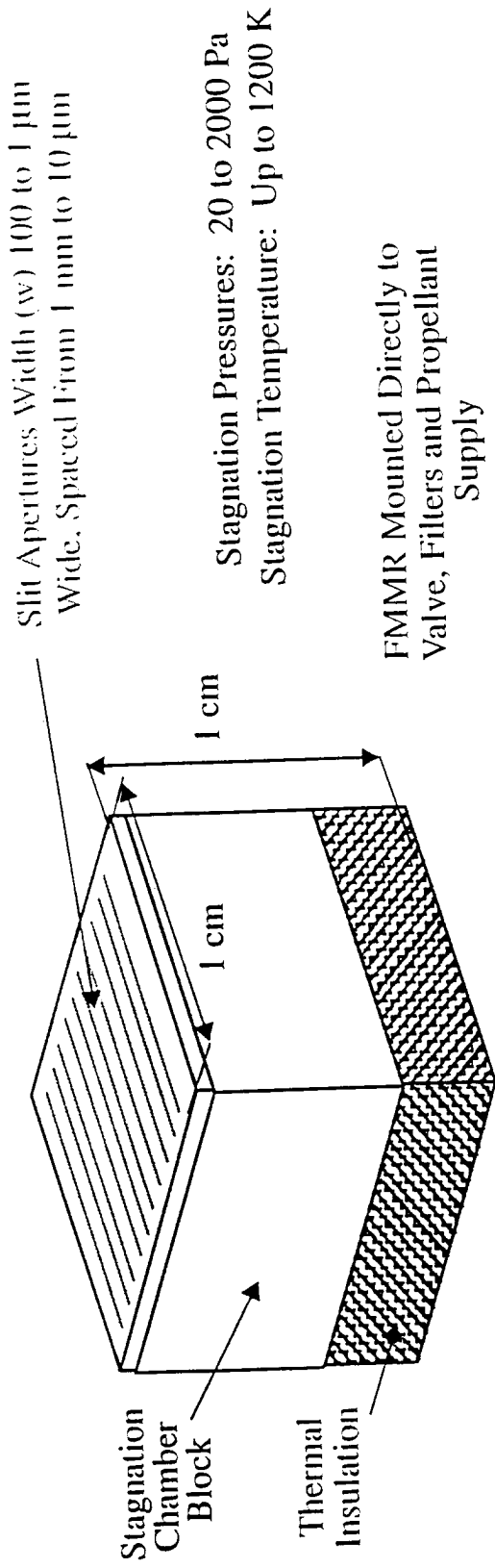

$$Kn_0 = \lambda/w \geq 2.5$$

Figure 1: FMMR Design

- Earth Observer Described by S. Janson
 - Mass: 1/3 kg
 - GEO
 - $\Delta V \approx 100$ m/sec for Control System With 0.1 mN Thrust
- Use a One Nozzle Slot, 100 μm FMMR Operating on NH_3 at 1200 K
- With Pulsed Heating of Thin Film Heaters Only When Thrusters Operating, Get Power Usage of 0.24 W During Thruster Firing
- Propellant Mass Fraction 0.1 or 0.033 kg and Volume of 55 cm^3

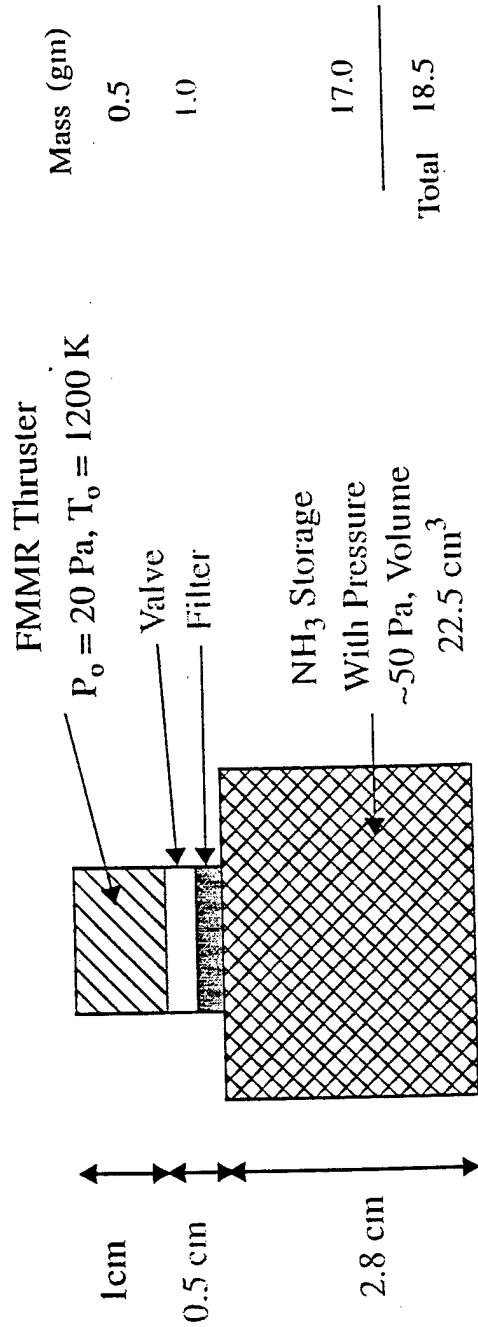

Figure 2: FMMR Applied to Aerospace Corporation Nanosatellite

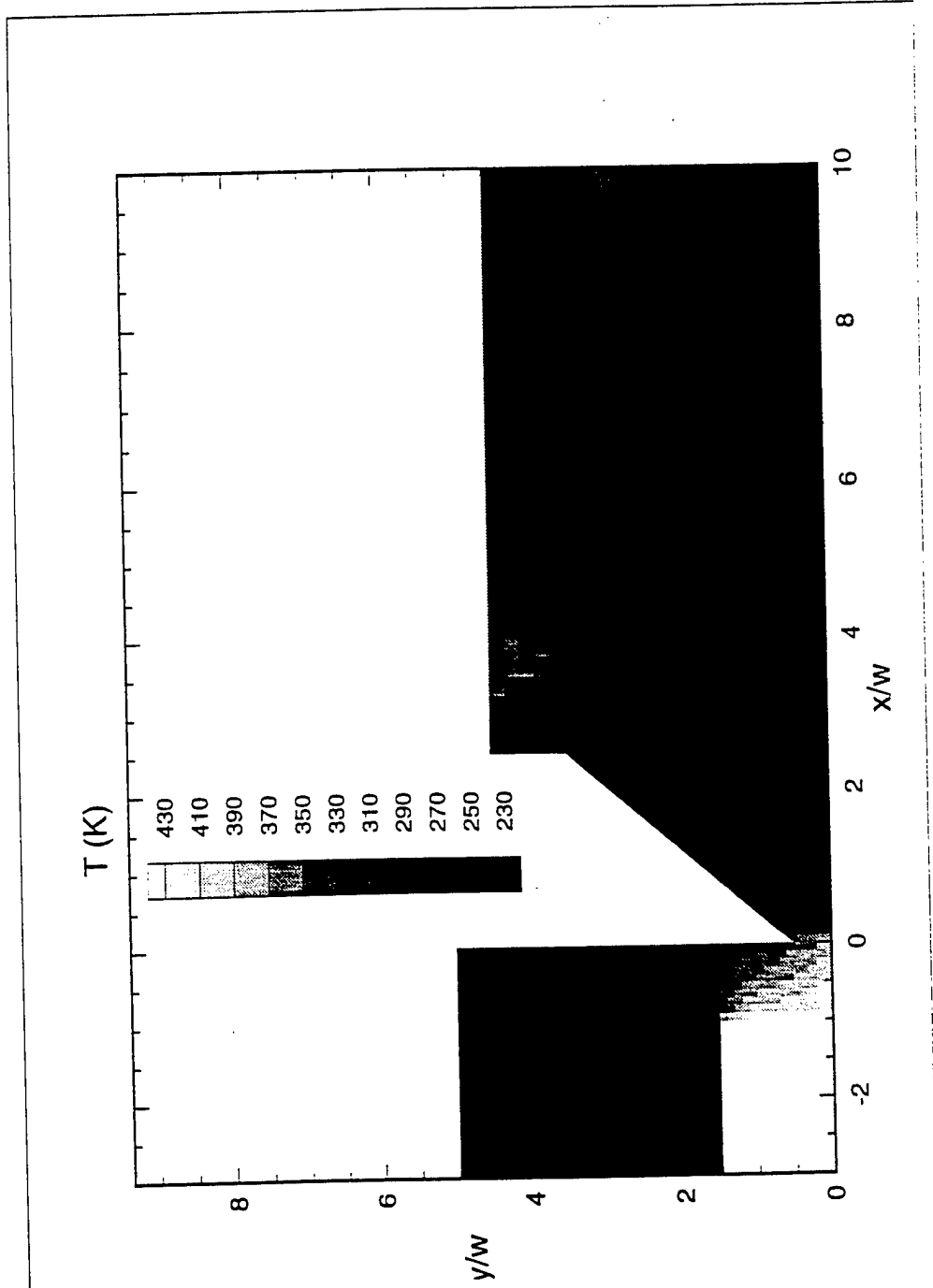

Figure 3: Translational Temperature Contours for the Nominal FMMR Configuration with a Stagnation Temperature of 600 K.

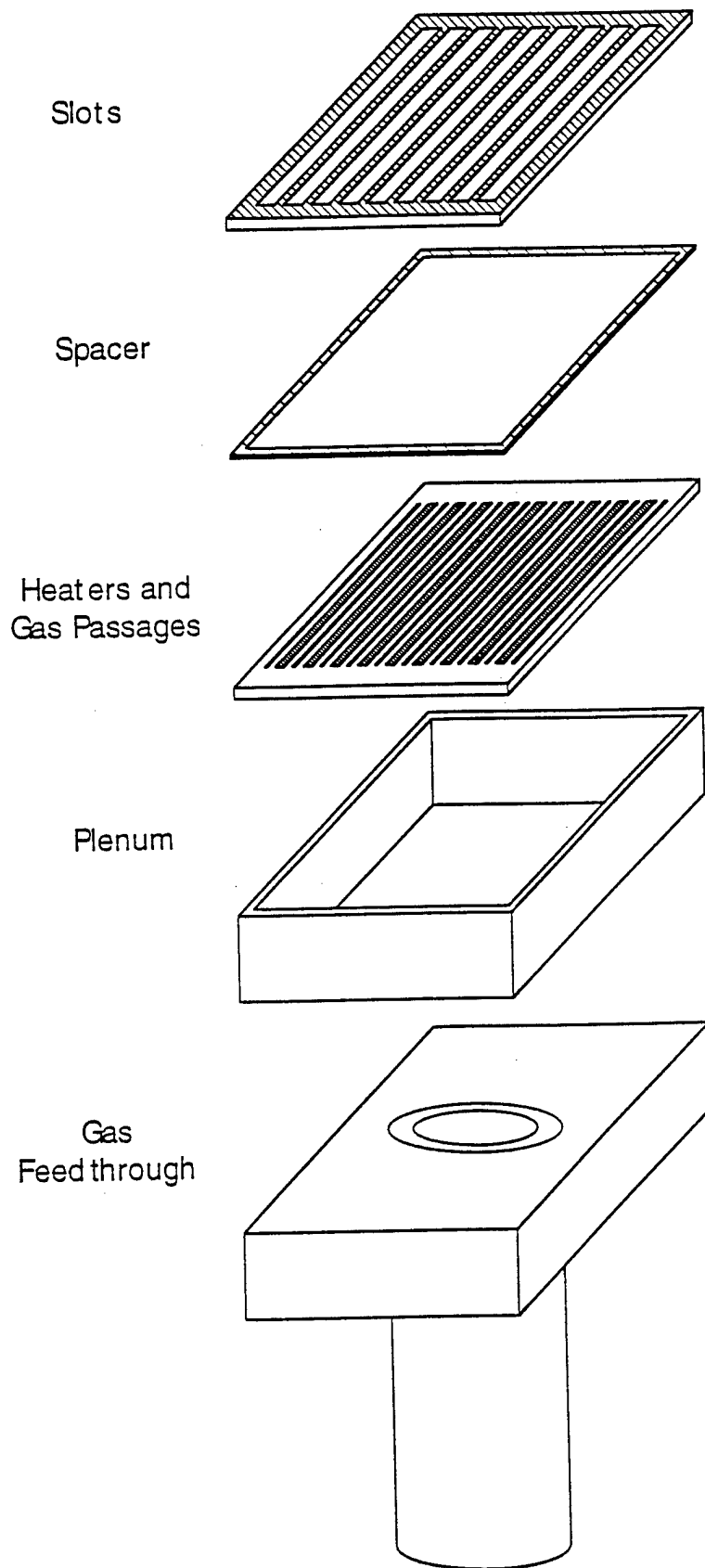

Figure 4: Exploded view of the FMVR.