

59996

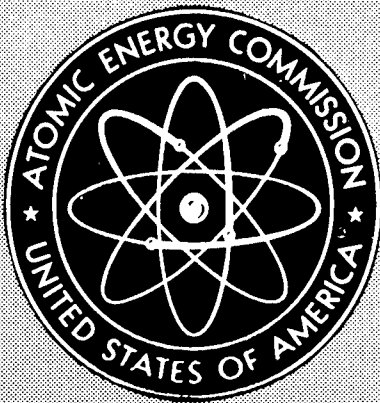

AMPTIAC

DP-860(Vol. II)

(~~STAINLESS STEEL~~ INFORMATION MANUAL)  
FOR THE SAVANNAH RIVER PLANT  
(VOLUME II. FABRICATION)

Compiled by  
W. C. Rion, Jr.

July 1964

**DISTRIBUTION STATEMENT A**  
Approved for Public Release  
Distribution Unlimited

Engineering Department  
Du Pont de Nemours (E. I.) & Co.  
Wilmington, Delaware

## LEGAL NOTICE

This report was prepared as an account of Government sponsored work. Neither the United States, nor the Commission, nor any person acting on behalf of the Commission:

A. Makes any warranty or representation, expressed or implied, with respect to the accuracy, completeness, or usefulness of the information contained in this report, or that the use of any information, apparatus, method, or process disclosed in this report may not infringe privately owned rights; or

B. Assumes any liabilities with respect to the use of, or for damages resulting from the use of any information, apparatus, method, or process disclosed in this report.

As used in the above, "person acting on behalf of the Commission" includes any employee or contractor of the Commission, or employee of such contractor, to the extent that such employee or contractor of the Commission, or employee of such contractor prepares, disseminates, or provides access to, any information pursuant to his employment or contract with the Commission, or his employment with such contractor.

This report has been reproduced directly from the best available copy.

Printed in USA. Price \$4.00. Available from the Clearinghouse for Federal Scientific and Technical Information, National Bureau of Standards, U. S. Department of Commerce, Springfield, Va.

DP-860  
Vol. II  
Metals, Ceramics, and Materials  
(TID-4500, 20th Ed.)

STAINLESS STEEL INFORMATION MANUAL  
FOR THE SAVANNAH RIVER PLANT  
Vol. II. Fabrication

Compiled by

W. C. Rion, Jr.  
Engineering Department  
Wilmington, Delaware

Issued: July 1964

This Manual was issued in parts between October, 1960 and December, 1962, to persons in the Du Pont Explosives Department, Atomic Energy Division, and in the Du Pont Engineering Department who were concerned with materials and equipment for the Savannah River Plant. All material has not been updated for the present printing. Where the reader has interest in a specific product referred to in this Manual, he is advised to contact the manufacturer for the latest information. The material used in the Manual has been referenced to give credit to the source wherever possible. Since it was originally intended for internal use only, there may be some instances where proper credit has not been given.

E. I. DU PONT DE NEMOURS & COMPANY  
EXPLOSIVES DEPARTMENT - ATOMIC ENERGY DIVISION  
TECHNICAL DIVISION - SAVANNAH RIVER LABORATORY  
AIKEN, SOUTH CAROLINA

CONTRACT AT (07-2) - 1 WITH THE  
UNITED STATES ATOMIC ENERGY COMMISSION

## CONTENTS

### VOLUME I. PROPERTIES

Volume I contains the following sections, which are further enumerated in the Table of Contents of Volume I.

1. Classifications and Characteristics of the Stainless Steels
2. Composition and Properties
3. Forms of Corrosion
4. Resistance to Corrosion, Oxidation, and Radiation
5. Structure

### VOLUME II. FABRICATION

#### 6. FABRICATION

- 6.1 Welding
  - 6.1.1 Weldability
    - 6.1.1.1 General
    - 6.1.1.2 Austenitic Stainless Steels
    - 6.1.1.3 Straight Chromium Stainless Steels
  - 6.1.2 Welding Processes for Corrosion Resistant Equipment
  - 6.1.3 Welding Rods and Electrodes
    - 6.1.3.1 ASTM Specifications
    - 6.1.3.2 Welding Filler Metal Comparison Charts
    - 6.1.3.3 Weld Metal Composition vs. Base Metal Composition
    - 6.1.3.4 NEMA Color Codes for Welding Rods and Electrodes
  - 6.1.4 Techniques
    - 6.1.4.1 Tube to Tube Sheet Welds
    - 6.1.4.2 Butt Welds in Pipe
    - 6.1.4.3 Welding of Stainless Steel Clad Plate
  - 6.1.5 Welding to Dissimilar Metals
    - 6.1.5.1 General
    - 6.1.5.2 Austenitic Stainless Steels to Carbon or Low Alloy Steels
    - 6.1.5.3 Ferritic and Martensitic Stainless Steels to Low Carbon or Low Alloy Steels
    - 6.1.5.4 Austenitic Stainless Steels to Ferritic or Martensitic Stainless Steels
    - 6.1.5.5 Welding One Type of Austenitic Stainless Steel to Another Austenitic Stainless Steel Type
    - 6.1.5.6 Austenitic Stainless Steels to Copper and Copper Base Alloys
    - 6.1.5.7 Austenitic Stainless Steels to Nickel and Nickel Base Alloys

20020111 031

- 6.1.6 Overlay Techniques
  - 6.1.6.1 General
  - 6.1.6.2 Welding Method
  - 6.1.6.3 Welding Electrodes
  - 6.1.6.4 Preheating and Interpass Temperature
  - 6.1.6.5 Stress Relieving
  - 6.1.6.6 Inspection
  - 6.1.6.7 Repair of Defective Areas
- 6.2 Brazing
  - 6.2.1 Definition
  - 6.2.2 Principles of Operation
  - 6.2.3 Brazing for Low and Moderate Temperature Applications
  - 6.2.4 Brazing for High Temperature Applications
  - 6.2.5 Applications
- 6.3 Soldering
  - 6.3.1 Definition
  - 6.3.2 Applications
  - 6.3.3 Joint Design
  - 6.3.4 Fluxes
  - 6.3.5 Solders
  - 6.3.6 Application of Solder
  - 6.3.7 Flux Removal
  - 6.3.8 Solder Specifications
- 6.4 Thermal Cutting
  - 6.4.1 General
  - 6.4.2 Oxygen Gas Cutting
  - 6.4.3 Arc Cutting
  - 6.4.4 Powder-Cutting Process
  - 6.4.5 "Heliarc" Cutting
- 6.5 Machinability
  - 6.5.1 General
  - 6.5.2 Machining the Nonhardenable Austenitic Chromium Nickel Grades
  - 6.5.3 Machining the Hardenable Chromium Stainless Grades
  - 6.5.4 Machining the Nonhardenable Chromium Stainless Grades
- 6.6 ASME Code Fabrication Information
  - 6.6.1 General
  - 6.6.2 Conditions of Service
  - 6.6.3 Materials
  - 6.6.4 Design
  - 6.6.5 Fabrication
    - 6.6.5.1 General
    - 6.6.5.2 Marking and Mill Test Reports
    - 6.6.5.3 Weld Metal Composition
  - 6.6.6 Heat Treatment
    - 6.6.6.1 Thermal Stress Relieving
    - 6.6.6.2 Carbide Solution Annealing
  - 6.6.7 Inspection and Tests
    - 6.6.7.1 General
    - 6.6.7.2 Impact Tests

- 6.6.7.3 Welded Test Plates
- 6.6.7.4 Penetrant Oil and Powder Examination
- 6.6.7.5 Radiographic Examination
- 6.6.7.6 Radiographic Inspection Techniques and Requirements
- 6.6.8 Castings
- 6.6.8.1 Quality Factors
- 6.6.8.2 Defects
- 6.6.8.3 Identification and Marking

## 7. HEAT TREATMENT

- 7.1 Austenitic Stainless Steels
- 7.1.1 Carbide Solution Anneal
- 7.1.2 Stabilization
- 7.1.3 Stress Relieving
- 7.2 Ferritic Stainless Steels
- 7.2.1 Annealing
- 7.3 Heat Treatment-Martensitic Stainless Steels
- 7.4 Heat Treatment of Precipitation Hardening Stainless Steels
- 7.4.1 17-4 PH
- 7.4.2 Stainless W
- 7.4.3 17-7 PH
- 7.4.4 PH 15-7 Mo
- 7.4.5 AM-350 and AM-355
- 7.4.6 A-286
- 7.4.7 17-10P
- 7.4.8 HNM
- 7.5 Ferritic-Austenitic Grade
- 7.5.1 Hardening

## 8. TESTING AND INSPECTION

- 8.1 Non-destructive Methods
- 8.1.1 Radiographic Inspection
- 8.1.2 Ultrasonic Testing
- 8.1.3 Eddy Current Testing
- 8.1.4 Liquid Penetrant Inspection
- 8.1.5 Magnetic Particle Inspection
- 8.2 Destructive Test Methods
- 8.2.1 Corrosive Evaluation

## 9. MILL PRODUCTS

- 9.1 Tubular Products
- 9.1.1 General
- 9.1.2 Production of Tubing and Pipe
- 9.1.2.1 Seamless Products
- 9.1.2.2 Welded Products
- 9.1.3 Specifications
- 9.1.3.1 ASTM Specifications
- 9.1.3.2 Military Specifications

9.1.4 Examples of Tubing Manufacturing Procedures

9.2 Plate

9.2.1 Definitions

9.2.2 Specifications

9.2.3 Compositions

9.2.4 Types of Finish

9.2.5 Tolerances

9.2.6 Testing and Inspection

9.2.7 Cost Information

## 10. MISCELLANEOUS INFORMATION

10.1 Galling Characteristics

10.2 Information on Wear Tests in Water

10.3 Dimensions for Seamless and Welded Pipe Commonly Used  
for Corrosion Service

## 6. FABRICATION

### 6.1 Welding

#### 6.1.1 Weldability

##### 6.1.1.1 General

Although there are problems of weld cracking with all three general types of stainless steels - austenitic, ferritic, and martensitic - the reasons behind the cracking difficulties differ greatly. For this reason, each type will be treated separately. The austenitic stainless steels in general are considered to be readily weldable, but there are cracking problems with certain grades both during welding and subsequent heat treatment. The ferritic stainless steels of nominal 17% and 27% chromium content exhibit weld cracking problems which increase in seriousness with increasing chromium content. Although the 15 to 16% grade has been used for welded chemical process equipment, the 27% chromium grade is seldom welded. The martensitic grades give welding difficulties because of their tendency to harden as the result of the heating and rapid cooling associated with welding. By use of proper preheating and post heating temperatures, these martensitic materials can be welded successfully.

##### 6.1.1.2 Austenitic Stainless Steels

- a. General. Since most of the major stainless steel equipment items at Savannah River Plant are made of Types 304 or 304L, there have been no serious weldability problems on these equipment items. As a general rule, filler metal of Type 308 or Type 308L is added for the first pass and all remaining passes. There have been some minor difficulties with root pass cracking when simple fusion of the edges to be joined was attempted in highly restrained locations. Cracking has been experienced in shop fabrication and field repair of equipment items of Type 309SCb. In efforts to use the inert gas shielded consumable electrode welding method for fabrication of Type 309SCb in a vendor's shop, weld metal and adjacent base metal cracked, even with the use of an electrode which deposited weld metal containing 5 to 7% ferrite. The base metal, being fully austenitic in this case, and the great amount of dilution of weld metal by base metal caused by the deeply penetrating welds, resulted in crack sensitive welds. On another occasion, attempts to weld, by simple fusion, on some of the small amount of Type 347 stainless steel pipe used at Savannah River Plant, resulted in weld cracking problems.

6.1.1.2a - 6.1.1.2c

The weldability problems in the straight chromium martensitic steels result from the deposited weld metal and the adjacent heated base metal becoming hard and brittle due to metallurgical transformations which take place on cooling from the welding temperatures. Those of the straight chromium ferritic grades result from the embrittling effect of severe grain growth and temper brittleness. The austenitic stainless steel welds, however, at room temperature are without exception extremely ductile and soft. Cracking as a rule occurs at high temperatures immediately after solidification of the weld metal. Once the metal has passed through this range without cracking, it will be ductile, regardless of the alloy. There are several theories which attempt to explain why certain of the austenitic grades are susceptible and others highly resistant to welded cracking. These will be discussed in a subsequent section.

- b. Constitution of Austenitic Stainless Steels as it Affects Weld Metal Cracking. From a practical standpoint, the constitution diagram for stainless steel weld metal as developed by Schaeffler (Metal Progress, Vol. 56, 1949) is a useful tool for determining approximately what the structure of a weld will consist of when the chemical composition is known. The diagram indicates the regions where austenite, martensite, ferrite, and mixtures of these structures exist. Fig. 1 shows the constitution diagram for stainless steel weld metal or "Schaeffler diagram" as it is commonly called. The control ranges used by Arcos Corporation for several welding electrode compositions are listed on the chart.

The presence of a minimum of 5 to 10% ferrite in the weld structure prevents cracking. Smaller quantities will frequently prove effective. Its beneficial action is probably due to its capacity for dissolving larger quantities of harmful elements like phosphorus, silicon, and niobium than can austenite, and to its action in creating an increased grain-boundary area, which thins out the liquid films and also lessens the tendency to segregation.<sup>2</sup>

- c. Nature and Incidence of Cracking<sup>2</sup>. Cracking in the weld in austenitic stainless steels, and in the base metal adjoining it, is due to the additive effects of metallurgical and mechanical factors, and is similar in appearance and in origin to corresponding defects occurring in castings.

Certain forms of weld-metal cracks are distinctive in appearance, and have been appropriately named. Crater cracks, for instance, are situated in weld craters and

c. Preheating and Interpass Temperature Control<sup>1</sup>. Preheating and maintaining the proper temperature until the weld is completed is advisable to insure the successful welding of the chromium steels. Preheating these steels:

- (1) Reduces the as-welded shrinkage stresses by lowering the temperature differential between weld and base metal and by lowering the yield point of the material.
- (2) Reduces the as-welded hardness of the hardenable grades appreciably, but only if the preheat is high enough to accelerate metallurgical transformations (above about 600°F).
- (3) Reduces the tendency to crack by reducing notch sensitivity at the preheating temperature. (This last effect is the principal advantage of preheating the high chromium, non-hardenable ferritic steels.)

Fig. 1 shows impact strength vs. temperature for a number of low carbon chromium steels. Notch sensitivity is closely related to a tendency to crack during welding in the case of the high chromium ferritic steels. The curves in the above figure show that a preheat temperature of 300°F. is sufficient for welding heavy sections of these materials without danger of cracking.

The lowest safe preheat temperature for the martensitic steels is difficult to determine, since hardness is the most influential property and it does not diminish appreciably with reasonable degrees of preheat. Experience must be relied upon to a greater extent in determining the necessary preheat for welding a particular martensitic steel.

11% to 14% Chromium Steels. These steels are intensely air hardening. Filler metal of the same composition as the base metal can be used, and when properly heat treated, has excellent mechanical properties in every respect, including good impact and fatigue strength. Preheating and interpass temperature control should be considered as mandatory. The hardness of the weld, as deposited is affected very little by preheating unless the preheat temperature is above 600°F., which is frequently impractical. Increasing the preheat temperature results in a deeper heat-affected zone, but other benefits make the use of the highest practical preheat temperature desirable. Experience has shown that weldments of these steels should be heat treated without allowing the preheat temperature to drop after welding. Such practice often entails several inter-stage heat treatments, but their cost is often justified in view of the cracking hazard which exists if the weldment is allowed to cool before heat treatment. Because of

### 6.1.1.3c

the common applications, most of the welding has been done with austenitic filler metal such as Type 309 or 310. If such filler metals are used, the weld will be ductile in the "as-deposited" condition, but preheating and interpass temperature control, as described above, should be exercised to prevent cracking in the heat affected zone of the base metal.

14 to 18% Chromium Steels. Steels containing 14 to 18% chromium may be either a martensitic steels with 14% chromium, which quenches to a very high hardness, or a completely ferritic, single-phase alloy with 18% chromium, which has no transformation points. Welding of the martensitic steels within this range is accomplished by the same general practices as previously set forth for the 11 to 14% chromium steels. In general, welding of the completely ferritic steels containing 18% chromium will follow the same rules as will be set forth below for the 20 to 30% chromium steels.

An alloy close to the middle of this range, containing 15 to 16% chromium, has been used in large quantities in ammonia oxidation units for the manufacture of nitric acid, in vessels for the storage of this acid, and in tank cars for its transportation. These steels are neither as notch sensitive as the 18% chromium steels nor as air-hardening as the 14% chromium steels. Equipment of this material is generally welded with electrodes depositing the same analysis as the base material.

A study of the notched-bar impact properties of these steel (See Fig.2) as they are affected by temperature will show the reason for preheating materials within this chromium range before welding and should also relieve anxiety over the notch sensitivity of the welds when operating above 150°F. The transition from a brittle cleavage fracture to a ductile one occurs between temperatures of about 100° and 250°F., and when the fracture is completely fibrous the notched-bar impact strength is excellent. Plate material, because of its fibrous structure, will show much higher values under notched-bar testing at room temperature than weld metal, because the latter, although only partially ferritic, is composed of large columnar grains which are only partially refined by heat treatment.

20 to 30% Chromium Steels. Steels having 20 to 30% chromium are nonhardening and notch sensitive. They are single-phase ferritic steels which cannot be refined by heat treatment. In multiple-pass welds, the heat of welding does not refine underlying layers of weld metal. It therefore causes grain growth with an increase in notch sensitivity in the heat affected zone. Austenitic filler

metal is generally recommended for welding steels in this range since the straight chromium deposits are generally considered to be too brittle. The effect of rolling when producing plate material is to break down coarse dendritic grains of the ingot and produce a fibrous structure with favorable directional properties. An increase in notch sensitivity takes place in the heat affected zone of weldments as the result of recrystallization and grain growth. Fig. 3 shows the effect of temperature on notched-bar impact strength of 27% chromium weld metal.

d. Post Welding Heat Treatments<sup>1</sup>

11 to 14% Chromium Steels. A tempering treatment for softening and stress relieving low-carbon chromium steels in this range is the general practice. The temperatures usually employed range from 1250° to 1400°F. The soaking time required will vary with the temperature used. Holding for two hours at 1400°F. will have the same effect as four hours at 1300°F. These steels are air cooled after the tempering treatment.

14 to 18% Chromium Steels. This range of chromium covers the transition zone of the chromium steels. A low-carbon steel with 17% chromium will be a single-phase alloy, almost completely ferritic, whereas a steel with 14.5% chromium will harden perceptibly upon quenching. However, the heat treatment for any steel falling within these limits is the same. Heating to from 1400° to 1450°F. and soaking for a minimum of four hours for thicknesses up to one inch, with an increase of one hour for each additional inch of thickness is recommended as the heat treatment for these steels. A weldment should be cooled in the furnace down to 1100°F., after which it should be removed from the furnace and air cooled. Slow cooling through the 750° - 1050°F. range will cause temper brittleness.

20 to 30% Chromium Steels. Rapid quenching following a long soaking period at from 1600° to 1650°F. is necessary for steels in this range in order to develop their maximum toughness and ductility. Soaking periods up to ten hours are recommended, although shorter soaking times may be acceptable if the best mechanical properties are not required. Prolonged holding of these ferritic steels at temperatures from 750° to 1050°F. or slow cooling through this range will cause a deterioration in their properties, resulting in marked embrittlement. While at the embrittling temperature, and at all temperatures above about 250°F., these alloys are tough and ductile.

6.1.1.3 - Fig. 1

Sources of Information:

1. The material in Paragraphs 6.1.1.3 (a), (c), and (d) has been taken from the Welding Handbook, Section Four, 1960, published by the American Welding Society.
2. Borland, V. C., and Younger, R. N., "Some Aspects of Cracking in Welded Cr-Ni Austenitic Steels," British Welding Journal, Jan. 1960.
3. Soldan, H. M., Mayne C. R., "Ductility Related to Service Performance of Heavy - Wall Austenitic Pipe Welds," Welding Journal, March 1957.

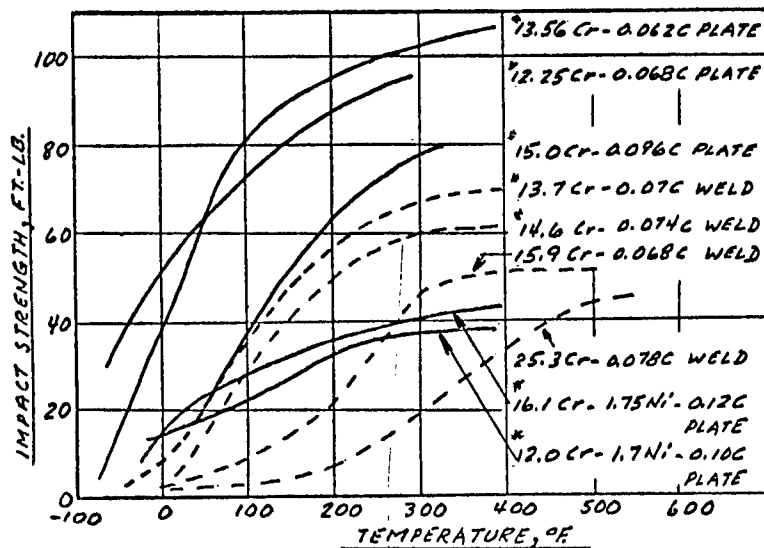

Fig. 1 - Curves showing impact strength vs. temperature for a number of weldments. Specimens marked with an asterisk are 0.315 in. wide x 0.315 in. thick with the standard notch through the 0.315 in. thickness.

6.1.1.3 - Figs. 2 and 3

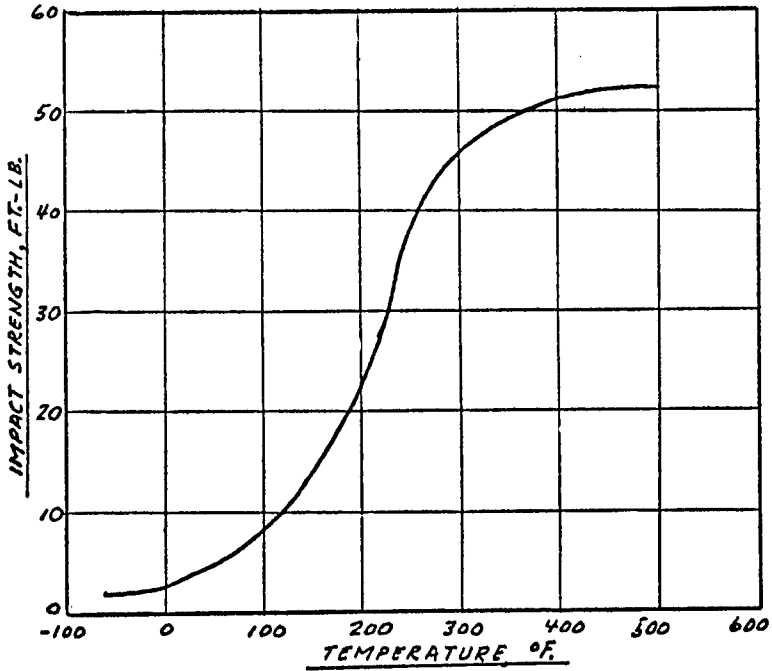

Fig. 2 - Effect of temperature on notched-bar impact strength of 16% Cr weld metal. Charpy specimen with Izod vee notch.

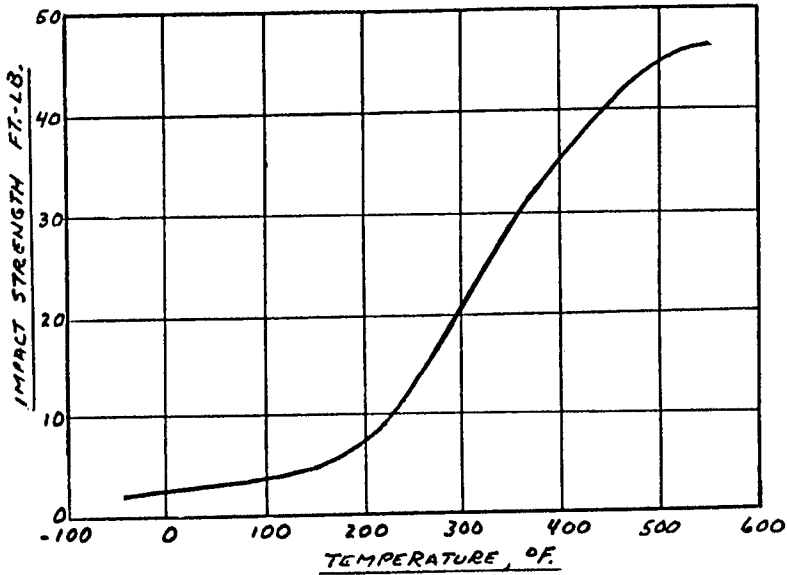

Fig. 3 - Effect of temperature on notched-bar impact strength of 27% Cr weld metal modified with 0.22% Ni. Charpy specimen with Izod vee notch.

## 6.1.2 - 6.1.2.2b

### 6.1.2 Welding Processes for Corrosion Resistant Equipment

#### 6.1.2.1 General

The welding processes generally employed in the shop and field fabrication of stainless steel piping and equipment and for the deposition of stainless steel overlays on carbon steel are the manual metal-arc process using coated electrodes, the submerged arc process, the inert gas-shielded non-consumable electrode process and the inert-gas-shielded consumable electrode process. Each of these major welding processes will be discussed in detail and fields of application, advantages and disadvantages will be listed.

Electron-beam welding has not been used in the fabrication of equipment for Savannah River Plant, but it has been used advantageously by others in the fabrication of nuclear fuel elements. Because it is a newly developed process which has many potential applications and since many persons are not familiar with the process it will also be discussed in this section.

#### 6.1.2.2 Manual Metal Arc Process

a. General. The manual metal arc process with coated electrodes is the most widely used welding method and is found in all fabrication shops. In this process, the arc is struck between a metal electrode and the work piece. The heat of the arc fuses not only the work material but also the electrode. The electrode is in the form of a flux covered wire of suitable material. The fused electrode material passes through the arc in droplet form and unites with the fused base metal to form the welded joint. (See Fig. 1)

b. Welding Electrode Coatings. In metal arc welding, the metallic electrode is covered with a thick layer of fluxing ingredients. These flux coverings function in several ways to produce weld metal of high mechanical properties:

- (1) The flux coverings are usually consumed more slowly than the metal of the electrode, thus forming a cupped end that shields the arc partially from the air.
- (2) Combustion of the fluxes produces an envelope of gases around the arc which excludes the oxygen and nitrogen of the air from contact with the molten metal of the weld.
- (3) The fluxing ingredients eliminate impurities from the molten metal of the weld by scavenger action.

#### 6.1.2.2b - 6.1.2.2d

- (4) A protective slag covering is formed that covers the top of the weld and protects the molten metal from contamination by oxygen and nitrogen from the air. It also retards the cooling rate of the weld.
- (5) Alloying elements desired in the weld are sometimes supplied from the flux covering. In the case of Type 309SCb electrodes, the core wire is generally Type 309S stainless steel and the columbium is included in the flux.
- (6) Materials are placed in the coatings to increase the arc stability by virtue of their ease of ionization or greater emission of electrons. Materials may also be added to make the flow of metal across the arc more uniform by reducing the adhesive force between the molten metal and the end of the electrode, or by changing the surface tension of the molten metal so that globular formation is smaller and more uniform.

c. Welding Electrode Specifications. Par. 6.1.4.1, Table 2 gives the chemical requirements of the stainless steel welding electrodes specified in A.S.T.M. A298. Special electrode compositions not listed by A.S.T.M. can be obtained from welding rod manufacturers.

d. Advantages.

- (1) The process is universally known. There are many skilled metal-arc welders available.
- (2) Stainless steel electrodes of special chemical composition and controlled ferrite content are relatively easy to obtain since standard core wires can be modified by welding electrode manufacturers by additions to the flux coating.
- (3) The process is not affected by wind velocities as are the inert-gas shielded arc processes.
- (4) The electrode holder is not bulky. Welding in confined places can be accomplished by bending the electrode.
- (5) The welding can be accomplished in any position.
- (6) The process is considered by many to be the least expensive method of welding.
- (7) Heat input and resultant warpage is less than with the inert-gas-shielded tungsten arc method.

## 6.1.2.2d - 6.1.2.2f

### e. Disadvantages

- (1) The process is based on a slag blanket. There is always a danger of slag inclusions.
- (2) Careful control of the pool of weld metal is not as easy as with the inert-gas-shielded tungsten arc method.
- (3) Visibility of the molten pool is impaired by the slag.
- (4) The process is not adaptable to welding thin gage materials.
- (5) In pipe welding the weld root penetration is not as smooth as when the inert-gas-shielded tungsten-arc method is used.
- (6) In the case of extra low carbon welds, the metal deposited by the manual metal-arc method normally has slightly higher carbon content than that deposited by the inert-gas-shielded methods.

f. Applications. At Savannah River Plant the usage of the manual metal-arc method with coated electrodes has decreased in the past few years with the increasing usage of the inert-gas-shielded methods.

There has been very little welding of stainless steel pipe at Savannah River Plant by the manual metal-arc method. There has been considerable repair work on process vessels by this method and it has been used in maintenance work to weld tubes to tube sheets. Much of the welding by fabricators on stainless steel process equipment for Savannah River has been performed with the manual metal-arc method. Overlay welding at certain locations on HWCTR reactor vessel was performed by this method.

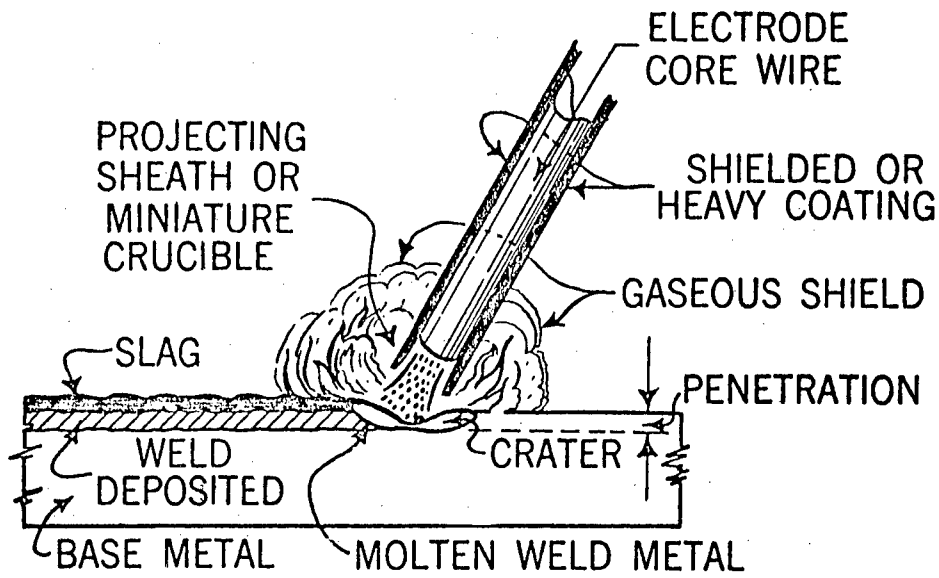

Fig. 1 Arc Zone in Manual Metal-Arc Welding

### 6.1.2.3 - 6.1.2.3c

#### 6.1.2.3 Submerged-Arc Process

a. Definition. Submerged-arc welding is an arc welding process where an electric arc is formed between the work and a bare consumable electrode, and in which the welding electrode, molten weld metal, and adjacent base metal are protected by a blanket of granular, fusible material which is heaped on the work. Fig. 1<sup>1</sup> shows a cutaway view of the welding zone in submerged arc welding.

#### b. General Scope<sup>1</sup>

1. Welding current - Currents up to 4,000 amperes a.c. or d.c. on a single welding wire electrode have been used. (In general much lower current values are used for stainless steel welding.)
2. Thickness range - One pass welding up to 3 in. thickness and multipass welding up to any thickness can be done.
3. Welding speed - Up to 200 in. per minute with a single welding wire. With more than one electrode in the same welding zone, higher speeds may be attained.
4. Position - A high welding current with the resulting high rate of heat input creates a large pool of liquid metal. When such conditions are used, welds must be kept horizontal to prevent spilling. Welds in which the pool is small may be inclined as much as 15 degrees from the horizontal without causing difficulties. If the size of the individual passes is limited, horizontal welds can be made on vertical surfaces if a suitable support is provided for the granular welding composition.

c. Description of the Welding Operation.<sup>1</sup> The heat evolved by the passage of the electric current through the welding zone melts the end of the wire and the adjacent edges of the workpieces, creating a puddle of molten metal. This puddle is in a highly liquid state and is turbulent. For these reasons, any slag or gas bubbles are quickly swept to the surface. The granular welding composition completely shields the welding zone from contact with the atmosphere. A small amount of the composition fuses. This fused portion serves several functions; it provides a medium through which the electric passes from rod to work; it completely blankets the top surface of the weld, preventing atmospheric gases from contaminating the weld; it dissolves and thus eliminates impurities that separate themselves from the molten steel and float to its surface and thus also can be the vehicle for adding certain alloying elements.

As the welding zone moves further down the seam the fused welding composition cools and hardens into a brittle, glasslike material which protects the weld until cool, then usually detaches itself completely from the weld.

d. Applications. The submerged-arc process is suitable for the deposition of welds of high quality in the manufacture of heavy wall stainless steel welded pipe and in the fabrication of equipment items from heavy plate. With the advent of the inert-gas-shielded consumable electrode welding process, however, much of the fabrication work that could be performed by the submerged-arc process has been taken over by the latter method.

A major field of application for the submerged-arc process is in the deposition of stainless steel overlay welds on carbon steel. In the fabrication of nuclear power reactor pressure vessels, this method has been widely used as a method of obtaining a stainless steel lining in the heavy wall carbon steel or low alloy steel vessels. In the deposition of overlay welds, the series submerged-arc method is used in which two wires are fed into the molten pool. In this case, the arc is formed between the wires rather than between the wires and the base metal in order to minimize penetration into the base metal. See Par. 6.1.6 for further details on overlay welding.

e. Advantages. The principal advantages of the submerged-arc process are its high deposition rate and high welding speed. In the case of the series-arc method in overlay welding, low base metal penetration is advantageous. Weld metal quality is good. In series-arc welding wires of two different compositions can be fed into the pool of molten metal to give welds of a desired non-standard composition.

f. Disadvantages. The inflexibility of the method is the principal disadvantage. Most installations are mechanized although manual welding can be performed. The use of the granular welding composition to shield the weld is more troublesome than the use of inert-gas as a shield in the case of the inert-gas-shielded methods. Welds in general, must be deposited in the flat position.

#### Source of Information

1. "Unionmelt" Welding Handbook, Linde Co., Division of Union Carbide Corp.  
"Unionmelt" is a trade-mark of Union Carbide Corp.

Par. 6.1.2.3 Fig. 1

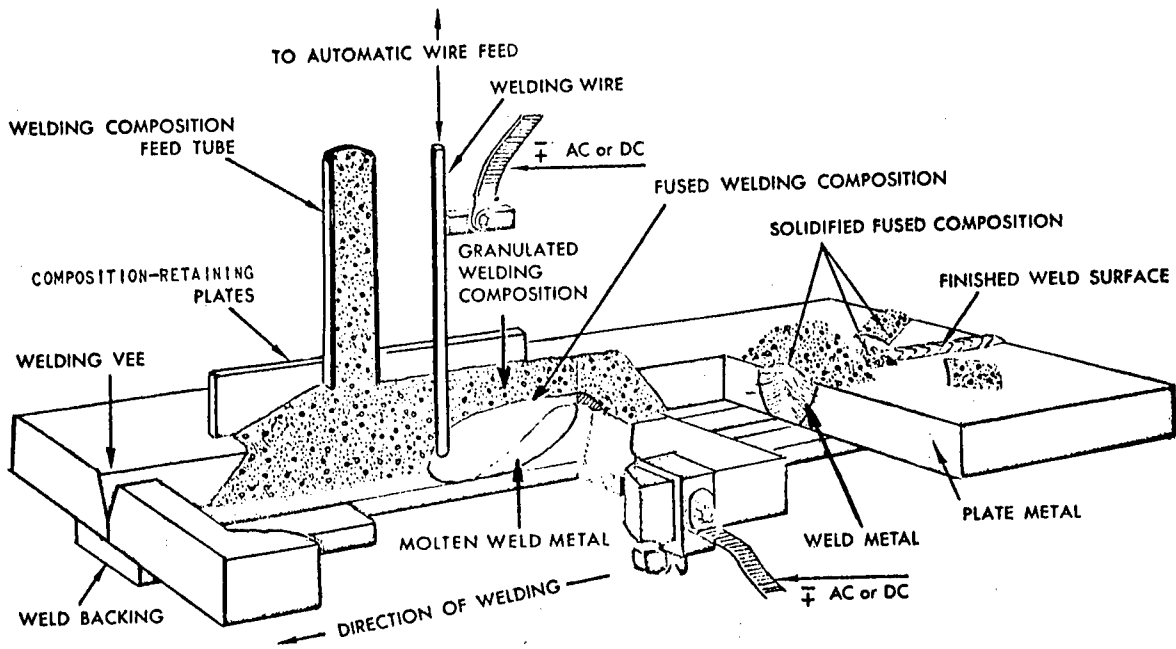

Fig. 1 Welding Zone in Submerged-Arc Welding

#### 6.1.2.4 Inert-Gas-Shielded Tungsten-Arc (or Non-Consumable Electrode) Process

- a. General. In this process, the arc is drawn between a tungsten electrode and the work. Means are provided by a special electrode holder to flow the inert gas around the arc. Air is displaced, thus protecting the tungsten electrode, weld metal and heated base metal from oxidation. See Fig. 1. This process is also commonly known as "Tig" welding.
- b. Equipment. The electrode holder is the heart of the inert-gas-shielded tungsten-arc process. It holds the tungsten electrode and conducts electricity into it by means of interchangeable electrode clamps and a conductor. It introduces a gaseous shield around the electrode and the molten weld metal by means of a ceramic nozzle. The electrode holder is cooled either by air or water. Air cooled electrode holders are furnished in capacities up to 150 amps and those which are water cooled in capacities to 500 amps. Fig. 2 shows a typical water cooled electrode holder.
- c. Welding Operations. In any type of welding, the best obtainable weld is one which has the same chemical, metallurgical, and physical properties as the base metal itself. To obtain such conditions, the molten weld puddle must be protected from the atmosphere during the welding operation; otherwise, atmospheric oxygen and nitrogen will combine readily with the molten weld metal and result in a weak porous weld. In inert-gas-shielded tungsten-arc welding, the weld zone is shielded from the atmosphere by an inert gas which is fed through the electrode holder. Either argon or helium may be used. Argon is recommended because of its general suitability for a wide variety of metals, and for the considerably lower flow rates required. Also, when using argon, variations in arc length have less effect on the heat input to the weld puddle.<sup>1</sup>

In inert-gas-shielded tungsten-arc welding it is customary to shield the root of the weld from atmospheric contamination by purging the air from the part being welded (such as the interior of a pipe or vessel) with a suitable inert gas. The same inert gases as used for shielding the arc may be employed for protecting the underside of the weld, but less expensive nitrogen has been found suitable. Welds in which the underside of the root is not shielded exhibit excessive oxidation and poor, incomplete or erratic penetration.

With this method of welding, the most common practice is to feed the filler rod by hand, as in the case in oxyacetylene welding. When light gauge material is being welded, the edges are joined by fusing them together rather than by adding filler metal. Some mechanized installations employ automatic wire feed.

6.1.2.4d - 6.1.2.4g

d. Filler Wire Specifications. Par. 6.1.4.1, Table 1 gives the chemical requirements of the stainless steel welding rods and bare electrodes specified in A.S.T.M. A-371. Special compositions not listed by A.S.T.M. can be obtained from welding rod manufacturers.

e. Applications. The inert-gas-shielded tungsten-arc process is one of the most valuable methods in the construction of chemical process equipment. At Savannah River Plant, this method has been used almost exclusively for the welding of stainless steel pipe, regardless of pipe size. There is some usage of this method in the fabrication of small vessels, but this application is more economically handled with the inert-gas-shielded consumable electrode method.

In the manufacture of welded stainless steel tubing and small diameter pipe the inert-gas-shielded tungsten arc method is used to join the edges of the formed stainless steel strip, without the addition of filler metal. With automatic wire feed it is used in the manufacture of larger size pipe. The method is also used almost exclusively in the welding of stainless steel tubes to tube sheets. It is the method used in automatic welding of tubes to tube sheets.

f. Advantages

- (1) The deposited metal, when correct procedures are used, is practically defect-free since there is no use of slag or flux in the process.
- (2) The process can be used on light gauge material since low current values with the resultant small, highly localized, and readily controllable arc are employed.
- (3) Visibility of the pool of weld metal is excellent since there is no slag or smoke to obstruct the operator's vision.
- (4) There is no loss of time by the welding operator in cleaning previously deposited weld beads in the deposition of multi-pass welds.

g. Disadvantages

- (1) The process must be carefully shielded from wind, since loss of the protective shield will result in welds of inferior quality.
- (2) The use of inert gas makes the welding equipment less portable than with conventional metal-arc welding with covered electrodes.

- (3) The deposition rate is slower than with the inert-gas-shielded consumable electrode method.
- (4) The use of inert gas results in additional material cost.

Source of Information

- 1. Linde Bulletin: "Heliarc" Manual Welding Equipment, 1959.  
"Heliarc" is a trade-mark of Union Carbide Corp.

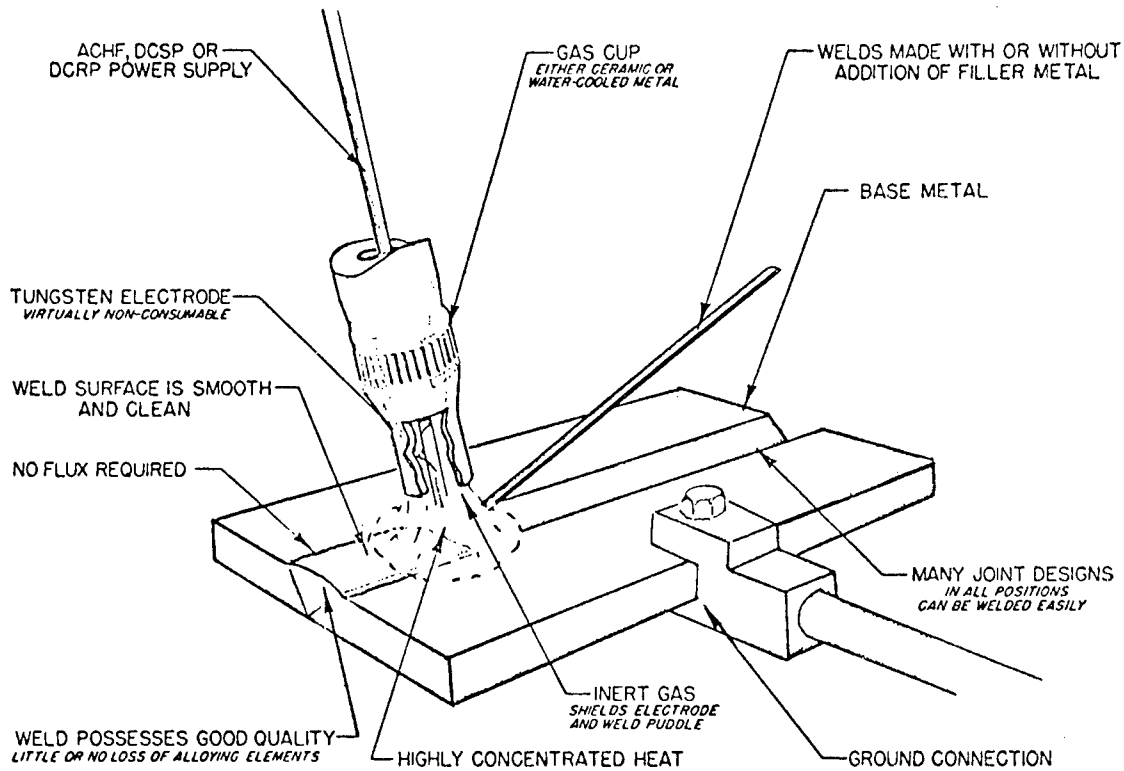

Fig. 1 Welding Zone in Inert Gas Shielded Tungsten Arc Welding

Par. 6.1.2.4 Fig. 2 - 6.1.2.5a

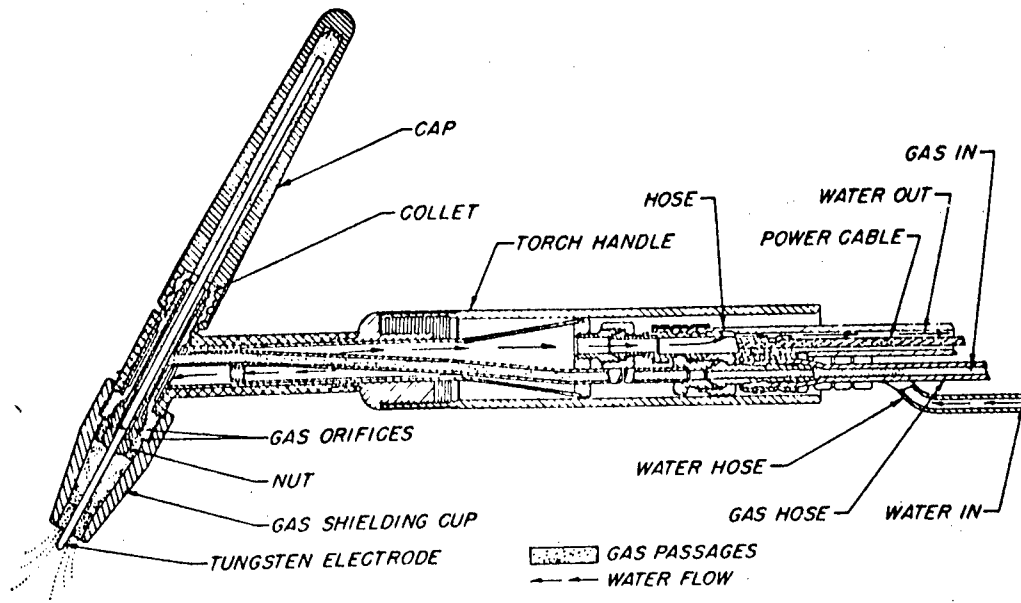

Fig. 2 Typical Water Cooled Electrode Holder

#### 6.1.2.5 Inert-Gas-Shielded Consumable Electrode Process

a. General.<sup>1</sup> This welding process is a variation of the covered electrode metal-arc process. It involves establishing and maintaining an arc between the work-piece and a bare consumable metal electrode. For practical purposes, the similarity to the covered electrode metal-arc welding process ends here. The wire is not fed manually, but mechanically, through a welding head from which a stream of shielding gas (usually inert) is simultaneously emitted.<sup>1</sup> The weld zone is protected from atmospheric contamination by a continuous blanket of inert gas, usually argon, although helium, and various mixtures such as oxygen with argon (and CO<sub>2</sub> with argon) have also proven satisfactory in welding specific metals.<sup>2</sup> A motorized wire feed unit pushes (or pulls) wire to the welding torch at a speed selected by the operator, and controlled electronically to prevent speed fluctuation.<sup>2</sup> This process is also commonly known as "Mig" welding. Fig. 1 shows typical equipment for this welding process.

b. Welding Operation - Conventional Equipment. Metal is ordinarily transferred from the electrode to the work in a spray-like fashion. The electrode has a small diameter, usually about 1/16 inch, and the process is characterized by the relatively high minimum currents required to create the spray-like transfer. Due to the spraying action involved, gas metal-arc welding is also characterized by fine droplets in the form of spatter adjacent to the molten puddle. This and the high current requirements have been something of a deterrent to the advancement of this welding process. In spite of these objections, its many definite advantages have caused it to be widely used. Direct current, reverse polarity is generally used for the welding of stainless steels.<sup>1</sup>

c. New Equipment. Heretofore, the consumable electrode process has had production application on relatively heavy weldments which could be positioned or rotated to permit welding in the downhand position. High current densities, in conjunction with wire diameters up to 3/32 inch resulted in high deposition rates. Another result was a relatively large, fluid puddle which precluded its use for light gage material and made difficult the welding of work in positions other than flat.

Several manufacturers of welding equipment now manufacture equipment that uses welding wire in the 0.020-0.035 in. diameter range. New developments have resulted in equipment with power characteristics that enable satisfactory welds to be made on stainless steel as thin as 18 ga. and which permit welding in all positions.

One new development is the Linde "Short Arc" method. This method uses argon-carbon dioxide gas mixtures for stainless steel welding. The power source and control equipment are such that short circuits (between wire and pool of molten metal) occur "dozens of times per second" which produces a small, cool puddle. With this method, all position welding is easily accomplished and wide gaps can be bridged.

Since many developments are being made in the welding equipment and shielding gases, interested persons are advised to contact the welding equipment manufacturers for latest information relative to this welding method.

d. Applications

- (1) The principal application for welding equipment of the conventional type is the fabrication of vessels and equipment from stainless steel plate, and in the manufacture of welded pipe where filler metal must be added.

#### 6.1.2.5d

- (2) The new equipment which uses small diameter wire in addition to being suitable for plate fabrication is suitable for sheet metal fabrication and will probably become a valuable tool for deposition of circumferential welds in pipe.

#### e. Advantages

- (1) Since wire is fed continuously from a roll, it is possible to weld continuously for relatively long periods of time without stopping. This is an advantage in the fabrication of vessels and other equipment items.
- (2) Deep penetration characteristics make it possible to utilize single pass welds in many cases.
- (3) Use of inert gas for shielding eliminates slag removal.
- (4) High welding speeds are possible.
- (5) The "dip-transfer" or "Short Arc" method makes it possible to weld in the vertical and overhead positions.

#### f. Disadvantages

- (1) With conventional equipment, high current requirements and large filler wire size made welding impossible on light gauge material.
- (2) With argon-carbon dioxide mixtures for shielding gas, a small amount of carbon pickup occurs in the deposited weld metal. The effect of the carbon pickup should be evaluated when the weldment will be subjected to severely corrosive conditions such as boiling nitric acid.

#### Sources of Information:

1. Welding Handbook, 4th Edition, Section 4, American Welding Society.
2. Linde Bulletin "Sigmatic" Manual Welding Equipment, 1960.  
"Sigmatic" is a trade-mark of Union Carbide Corp.

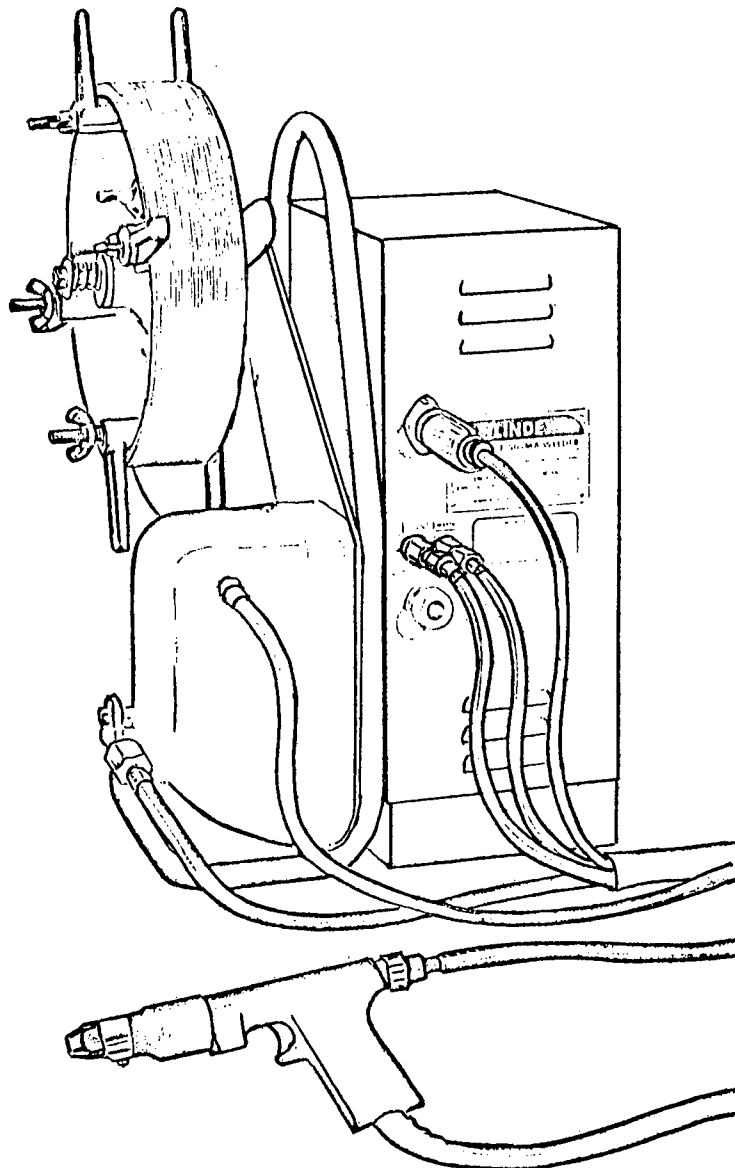

Fig. 1 Typical Equipment for Inert Gas Shielded Consumable Electrode Welding

## 6.1.2.6 - 6.1.2.6c

### 6.1.2.6 Electron-Beam Welding

- a. General.<sup>1</sup> Briefly, electron-beam welding consists of conversion of the kinetic energy of a high-velocity beam of electrons to heat when the electrons strike the surface of the workpiece. The thermal energy from the high-voltage stream of electrons is highly concentrated at the metal surface and is sufficient to overcome the capacity of the adjacent body to absorb it through conduction.
- b. Types of Apparatus.<sup>2</sup> At present, both high-voltage (50 to 100 kv) and low-voltage (10 to 30 kv) types of welding equipment are available. The low-voltage apparatus is less critical in adjustment and more easily operated, although the minimum focused spot size is several times greater in diameter than that obtained with high-voltage apparatus. In low-voltage equipment, those x-rays which are produced are soft enough to be absorbed by the walls of the evacuated chamber. Direct viewing ports may be provided to observe the welding position during operation. High voltage equipment requires lead shielding of appropriate thickness and indirect optical viewing systems.

Internal gaseous breakdown in the electron gun due to entrapped gas or metallic vapor liberated from the workpiece is a serious problem which plagues the electron-beam welding process. This problem is more difficult to circumvent at higher electron voltages.

For general purpose welding, low-voltage equipment is preferable. However in special applications where exceptionally high depth-to-width ratio is needed in the penetration pattern, high-voltage apparatus may be necessary.

- c. Description of Equipment.<sup>2</sup> Electron-beam welding apparatus consists of an electron gun with associated optics for shaping and focusing the beam; a welding chamber equipped with viewing ports (low voltage type machine), vacuum-sealed door for easy access to the interior, and suitable mechanical devices to permit relative motion between the workpiece and the focused spot of the electron beam; an evacuating system to pump down and maintain high vacuum in the welding chamber and electron-gun structure; and an electrical system consisting of power supplies, regulating devices and control equipment for the electron gun, mechanical pumps and motorized drives. Fig. 1 shows an electron optical system.

d. The Welding Process.<sup>3</sup> Electron-beam welding machines derive their unique effects in a manner which will be described in the following paragraphs.

Basically, a beam of electrons is emitted from a cathode, accelerated to a high velocity, and sharply focused to produce an extremely high energy density.

The unique nature of electrons has made it possible to control their activities with much precision. Thus, with the advent of sophisticated electron optics, enormous amounts of energy may be concentrated over very small areas. Actual energy densities on the order of 10 billion watts per square inch are now easily attainable with commercial equipment. The significance of this energy density capability, however, is not yet fully appreciated in that new and interesting phenomena are being discovered daily.

It may easily be understood that the bombardment of a solid by electrons necessarily results in the conversion of kinetic energy to thermal energy in the solid. In the case of high energy densities, however, this is not the complete story. It has been normally accepted that electrons are quickly diffused in a very small layer of material, and subsequent heating results from radial thermal conduction from the area of impingement. This, however, does not account for the unusually high depth to width ratios resulting from the use of high energy densities. With high voltage equipment depth-to-width ratios of heat-affected zones exceeding 25 to 1 have been experienced in various materials. Apparently the electrons are capable of vaporizing a fine path through the entire thickness of a solid resulting in localized "internal heating". It may be readily shown that electrons actually emerge from the opposite side of the material upon which the beam impinges. After operating parameters were properly adjusted, as many as four separate layers have been penetrated by the electron beam. Interestingly, a refocusing of the electron beam takes place within the material itself. The most important effect arising from the use of high energy densities is this propensity for internal refocusing accompanying the penetration of solid materials.

The consequence of internal refocusing may now be more fully appreciated. In addition to an internal heating effect resulting in extremely high depth-to-width ratios of the heat-affected zone, the refocused beam may actually penetrate material thicknesses exceeding an accumulation of 1 inch.

#### 6.1.2.6d - 6.1.2.6g

It is possible to draw an analogy to this process by the passing of a white-hot wire through a solid block of ice. Consider now the passing of an electron beam through a solid material. Parameters influencing energy density having been properly adjusted for a specific condition, it is possible to move the work piece at a given velocity under the electron beam. Rapid speeds are reported.

In general, it may be shown that high energy density electron beams produce narrow, sound, fine grained welds at very high speeds. The high welding speeds and energy densities provide conditions which drastically reduce the distortion and shrinkage usually associated with the normal techniques of materials joining.

e. Applications. There are few applications at present in the fabrication of chemical process equipment. In the nuclear field there has been some usage of the method in the fabrication of nuclear fuel assemblies (See Fig. 2)<sup>1</sup>. Some typical welds which can be made with this method are shown in Fig. 3.<sup>4</sup> Fig. 4<sup>3</sup> compares the fusion zone of a high-voltage electron beam weld with that formed by typical surface heating techniques.

#### f. Advantages

- (1) Welds can be made through a solid sheet or plate into a hidden member beneath the sheet.
- (2) Large depth to width ratio results in thin heat affected zone with low shrinkage even in relatively thick members.
- (3) Very light gauge material (as thin as 0.003 in.) and fine wire can be welded.
- (4) Suitable for welding strongly reactive metals and alloys since welding is performed in a vacuum.
- (5) Welds are of excellent quality since gases are removed from the molten metal by the vacuum.
- (6) Metals with high thermal conductivity are easily welded.

#### g. Disadvantages

- (1) Equipment is not portable and is very expensive.
- (2) Size of workpiece limited by size of vacuum chamber of welding machine.

- (3) Highly skilled technicians required to operate machine.
- (4) Welding is slow since each piece to be welded must be introduced into the vacuum chamber and very accurately positioned.

Sources of Information:

1. Burton, G., Jr., and Frankhouser, W. L., "Electron-Beam Welding", Welding Engineer, Oct. 1959.
2. Greene, W. J., Banks, R. R., and Niedzielski, R. M., "A New Electron-Beam Welding Unit", Welding Journal, Aug. 1960.
3. Aemisegger, A. E., Jr., and Nyenhuis, H. A., "Super-Depth Welds Made With a High Energy Electron Beam - A Revolution in Welding", Welding Journal, Dec. 1961.
4. "Electron-Beam: Space Age Welding Process", Welding Journal, Feb. 1962.

Par. 6.1.2.6 Figs. 1 and 2

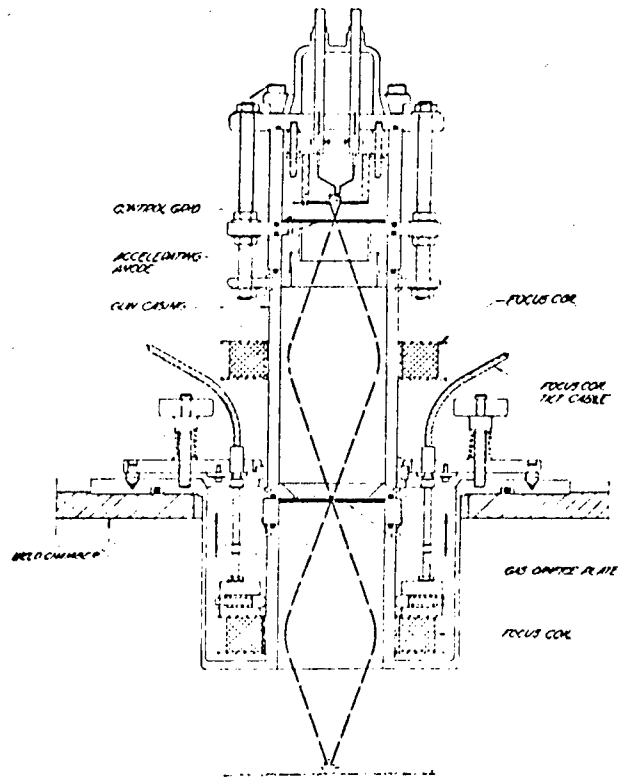

Electron optical system

Fig. 1

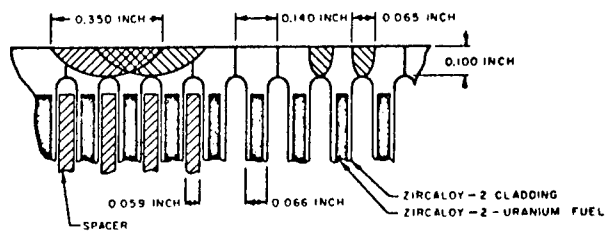

Fusion-zone geometry comparison of electron-beam welds with tungsten-arc welds in typical nuclear fuel-assembly cross section.

Fig. 2

Par. 6.1.2.6 Figs. 3 and 4

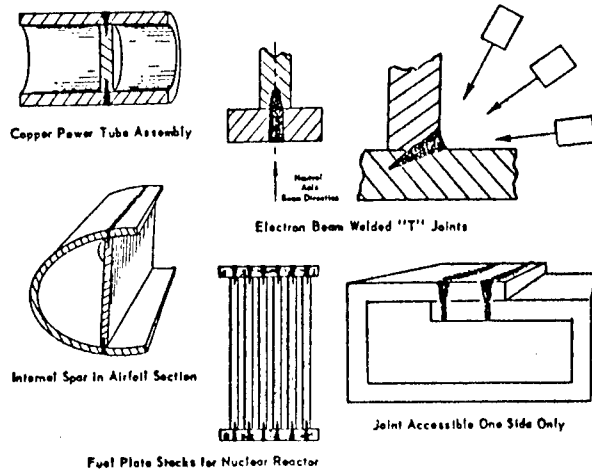
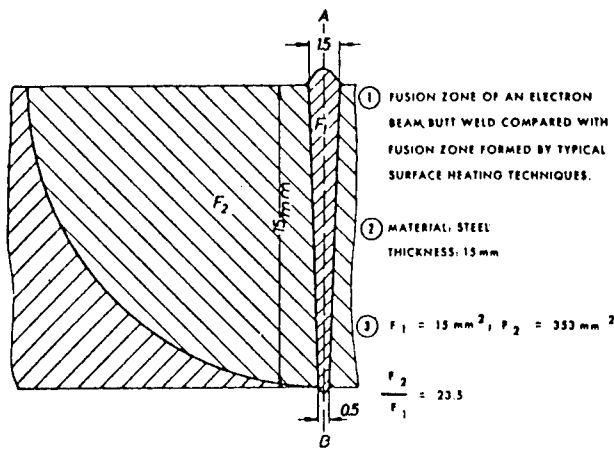

Fig. 3

Weld joint types that can be made with electron-beam process.



Fusion zone formed by electron beam welding

Fig. 4

## 6.1.3 - 6.1.3.1

### 6.1.3 Welding Rods and Electrodes

#### 6.1.3.1 A.S.T.M. Specifications

- a. Welding Rods and Bare Electrodes. A.S.T.M. A371-53T covers "Corrosion-Resisting Chromium and Chromium-Nickel Steel Welding Rods and Bare Electrodes". These are the welding rods and filler wire used with the inert gas shielded tungsten arc (or non-consumable electrode) welding method and the inert gas shielded consumable electrode method.

Table 1 gives chemical requirements specified in A.S.T.M. A371-53T for welding rods and bare electrodes.

It will be noticed that Types 309S and 309SCb are not included in the chemical requirements table. These compositions can be obtained from welding rod manufacturers, however. Type 309SCb is somewhat difficult to obtain since it is not widely used as bare rods and electrodes, and since the more widely used coated electrodes of 309SCb composition contain Type 309S core wire, the columbium being added through the coating.

- b. Covered Welding Electrodes. A.S.T.M. A298-55T covers "Corrosion-Resisting Chromium and Chromium-Nickel Steel Covered Welding Electrodes". Under this specification, welding electrodes are classified as suitable for welding with direct current only or for welding with direct current or alternating current. Those suitable for use with direct current are identified by the number suffix "-15". For example, Type 308 electrodes suitable for use with direct current would be specified as E-308-15. The coating on such electrodes is called a lime coating. Those electrodes suitable for use with direct current or alternating current are identified by the number suffix "-16" (for example E-308-16). The coating on such electrodes is called a titania coating.

There is some controversy relative to the soundness of welds (with regard to hot cracking) made with titania type electrodes as compared with those made with lime type electrodes. Welding procedures for equipment for nuclear power use almost always specify that lime coated electrodes be used. This is also the case with Du Pont Standard Engineering Specifications covering welding with covered stainless steel electrodes. It is widely believed that welds made with stainless steel electrodes with titania coatings are more susceptible to cracking than those made with lime coated electrodes.

### 6.1.3.1

Discussions with welding electrode manufacturers relative to this problem have resulted in comments that this is a problem with fully austenitic deposits such as Type 310, but that no problems should result when the deposit is partially ferritic as is the case with Type 308.

Table 2 gives chemical requirements for covered electrodes as specified in A.S.T.M. A298-55T. Although Type 309 and 309Cb are shown to have 0.15 and 0.12 min. % carbon, these grades can be obtained with .08% max. carbon.

In the case of covered electrodes, elements such as columbium which are present in small quantities, are frequently added through the coating on the electrode rather than through the core wire. The core wire composition is not necessarily the same as the composition of the weld metal deposited by the electrode. For this reason, the practice of removing the coating from covered electrodes and using the core wire as filler wire for inert gas shielded welding should be discouraged.

TABLE I.—CHEMICAL REQUIREMENTS

NOTE.—Analysis shall be made for the elements for which specific values are shown in this table. If, however, the presence of other elements is indicated in the course of routine analysis, further analysis shall be made to determine that the total of these other elements, except iron, is not present in excess of 0.70 per cent.

AWS-ASTM Classification Number	Carbon, per cent	Chromium, per cent	Nickel, per cent	Molybdenum, per cent	Columbium plus Tantalum, per cent	Manganese, per cent	Silicon, max, per cent	Phosphorus, max, per cent	Sulphur, max, per cent
ER 308.....	0.08 max	19.5 to 22.0*	9.0 to 11.0	...	...	1.0 to 2.5	0.60	0.03	0.03
ER 308L.....	0.03 max	19.5 to 22.0*	9.0 to 11.0	...	...	1.0 to 2.5	0.60	0.03	0.03
ER 309.....	0.12 max	23.0 to 25.0	12.0 to 14.0	...	...	1.0 to 2.5	0.60	0.03	0.03
ER 310.....	0.08 to 0.15	25.0 min	20.0 min	...	...	1.0 to 2.5	0.60	0.03	0.03
ER 316.....	0.08 max	18.0 to 20.0	12.0 to 14.0	2.0 to 2.5	...	1.0 to 2.5	0.60	0.03	0.03
ER 316L.....	0.03 max	18.0 to 20.0	12.0 to 14.0	2.0 to 2.5	...	1.0 to 2.5	0.60	0.03	0.03
ER 317.....	0.08 max	18.5 to 20.5	13.0 to 15.0	3.25 to 4.0	...	1.0 to 2.5	0.60	0.03	0.03
ER 330.....	0.15 to 0.25	15.0 to 17.0	34.0 min	...	...	1.0 to 2.5	0.60	0.03	0.03
ER 347.....	0.08 max	18.5 to 21.0*	8.5 to 10.5	...	10 X C min, 1.00 max	1.0 to 2.5	0.60	0.03	0.03
ER 410.....	0.07 to 0.12	12.0 to 14.0	0.6 max	0.6 max	...	0.6 max	0.50	0.03	0.03
ER 420.....	0.25 to 0.40	12.0 to 14.0	0.6 max	...	...	0.6 max	0.50	0.03	0.03
ER 430.....	0.10 max	15.5 to 17.0	0.6 max	...	...	0.6 max	0.50	0.03	0.03
ER 502.....	0.10 max	4.5 to 6.0	0.4 max	0.45 to 0.65	...	0.6 max	0.60	0.03	0.03

\* Chromium, min = 1.9 X nickel.

TABLE II.—CHEMICAL REQUIREMENTS FOR ALL-WELDED METAL.

NOTE.—Single values shown are maximum percentages except where otherwise specified.

AWS-ASTM Classification Number	Carbon,* per cent	Chromium, per cent	Nickel, per cent	Molybdenum, per cent	Columbium plus Tantalum, per cent	Manganese, per cent	Silicon, per cent	Phosphorus, per cent	Sulfur, per cent
E308.....	0.08	18.0 to 21.0	9.0 to 11.0	.....	.....	2.50	0.90	0.04	0.03
E308ELC.....	0.04	18.0 to 21.0	9.0 to 11.0	.....	.....	2.50	0.90	0.04	0.03
E309.....	0.15	22.0 to 25.0	12.0 to 14.0	.....	.....	2.50	0.90	0.04	0.03
E309Cb.....	0.12	22.0 to 25.0	12.0 to 14.0	.....	0.70 to 1.00	2.50	0.90	0.04	0.03
E309Mo.....	0.12	22.0 to 25.0	12.0 to 14.0	2.00 to 3.00	.....	2.50	0.90	0.04	0.03
E310.....	0.20	25.0 to 28.0	20.0 to 22.0	.....	.....	2.50	0.75	0.03	0.03
E310Cb.....	0.12	25.0 to 28.0	20.0 to 22.0	.....	0.70 to 1.00	2.50	0.90	0.04	0.03
E310Mo.....	0.12	25.0 to 28.0	20.0 to 22.0	2.00 to 3.00	.....	2.50	0.90	0.04	0.03
E312.....	0.15	26.0 to 31.0	8.5 to 10.5	.....	.....	2.50	0.75	0.04	0.03
E316.....	0.08	17.0 to 20.0	11.0 to 14.0	2.00 to 2.50	.....	2.50	0.90	0.04	0.03
E316ELC.....	0.04	17.0 to 20.0	11.0 to 14.0	2.00 to 2.50	.....	2.50	0.90	0.04	0.03
E317.....	0.08	18.0 to 21.0	12.0 to 14.0	3.00 to 4.00	.....	2.50	0.90	0.04	0.03
E318.....	0.08	17.0 to 20.0	11.0 to 14.0	2.00 to 2.50	6 X C min to 1.00 max	2.50	0.90	0.04	0.03
E330.....	0.25	14.0 to 17.0	33.0 min	.....	.....	2.50	0.90	0.04	0.03
E347.....	0.08	18.0 to 21.0 <sup>b</sup>	9.0 to 11.0	.....	8 X C min to 1.00 max	2.50	0.90	0.04	0.03
E410.....	0.12	11.0 to 14.0	0.60	.....	.....	1.00	0.90	0.04	0.03
E430.....	0.10	15.0 to 18.0	0.60	.....	.....	1.00	0.90	0.04	0.03
E502.....	0.10	4.0 to 6.0	0.40	0.45 to 0.65	.....	0.75	0.90	0.04	0.03

\* Carbon shall be analyzed to the nearest 0.01 per cent.

<sup>b</sup> Chromium shall be 1.9 X Ni, min, when so specified.

---

6.1.3.2 WELDING FILLER METAL COMPARISON CHARTS

AWS-ASTM Classification Numbers vs.  
Manufacturers' Designation

The comparison charts used in  
this section were taken from  
American Welding Society  
Technical Publication A5.0-59.

Table 1

Covered STAINLESS STEEL Electrodes

SEE TENTATIVE SPECIFICATIONS FOR CORROSION-RESISTING CHROMIUM AND CHROMIUM-NICKEL STEEL COVERED WELDING ELECTRODES (AWS A 5.4-55; ASTM A 298-55)

Manufacturers	AWS-ASTM Classification	E308-15	E308-16	E308ELC-15	E308ELC-16	E309-15	E309-16	E309Cb-15	E309Cb-16	E309Mo-15	E309Mo-16	E310-15	E310-16
Air Reduction Sales Co.	Airco 19-90C	Airco 19-9 AC-DC, Easyarc 308 AC-DC	-	Airco 19-9 ELC AC-DC	Airco 25-12 DC	Airco 25-12 AC-DC	-	Airco 25-12Cb AC-DC	-	-	-	Airco 25-20 DC	Airco 25-20 AC-DC
Alloy Rods Co.	Arcaloy Type 308 Lime	Arcaloy Type 308 AC-DC	Arcaloy Type 308ELC Lime	Arcaloy Type 308ELC AC-DC	Arcaloy Type 309 Lime	Arcaloy Type 309 AC-DC	Arcaloy Type 309Cb Lime	Arcaloy Type 309Cb-AC-DC	Arcaloy Type 309Mo Lime	-	-	Arcaloy Type 310 Lime	Arcaloy Type 310 AC-DC
Arcos Corp.	Chromend K, Aerocor 308, Fabricor 308	Stainlend K	Chromend K-LC	Stainlend K-LC	Chromend HC	Stainlend HC	Chromend 25/12 Cb	-	-	-	-	Chromend HCN, Aerocor 310, Fabricor 310	Stainlend HCN
Canadian Liquid Air Co., Ltd.	Arcaloy 308 Lime	Arcaloy 308 AC-DC	Arcaloy 308ELC Lime	Arcaloy 308ELC AC-DC	Arcaloy 309 Lime	Arcaloy 309 AC-DC	Arcaloy 309Cb Lime	Arcaloy 309Cb AC-DC	Arcaloy 309Mo Lime	-	-	Arcaloy 310 Lime	Arcaloy 310 AC-DC
Champion Rivet Co.	308-1	308-2	308 CF-1	308 CF-2	309-1	309-2	309 Cb-1	309 Cb-2	309 Mo-1	309 Mo-2	-	310-1	310-2
Eutetic Welding Alloys Corp.	-	Staintrode B AC-DC	-	-	-	Staintrode C AC-DC	-	-	-	-	-	-	Staintrode D AC-DC
Gases Agamex, S. A.	Suemex 19-9	-	-	Murex 308 Etc	Murex 309-15	Murex 309	-	Murex 309Lb	-	-	-	Suemex 25-20	Murex 310
Hornischfeger Corp.	Harstain 18-8	Harstain "A" 18-8	Harstain 18-8 ELC	Harstain "A" 18-8 ELC	Harstain 25-12	Harstain "A" 25-12	Harstain 25-12 Cb	Harstain "A" 25-12 Cb	Harstain 25-12 Mo	Harstain "A" 25-12 Mo	Harstain 25-20	Harstain "A" 25-20	Harstain "A" 25-20
Hobart Brothers Co.	308 DC	308 AC	308 ELC DC	308 ELC AC	309 DC	309 AC	309Cb DC	309Cb AC	309 Mo DC	309 Mo AC	-	310 DC	310 AC
Lincoln Electric Co.	Stainweld A5	Stainweld A7	-	-	-	-	Stainweld B-Cb	-	-	-	-	Stainweld D5	-
Marquette Mfg. Co., Inc.	-	No. 308	-	No. 308ELC	-	No. 309	-	No. 309Cb	-	-	-	-	No. 310
Maurath, Inc.	Maurath E-308-15	Maurath E-308-16	-	-	Maurath E-309-15	Maurath E-309-16	Maurath E-309-Cb-15	Maurath E-309-Cb-16	Maurath E-309-Mo-15	Maurath E-309-Mo-16	-	Maurath E-310-15	Maurath E-310-16
McKoy Co.	18-8 DC Lime, 18-8 DC Titania	18-8 AC-DC	18-8 ELC DC Lime, 18-8 ELC DC Titania	18-8 ELC AC-DC	25-12 DC Lime, 25-12 DC Titania	25-12 AC-DC	25-12 Cb DC Lime, 25-12 Cb DC Titania	25-12 Cb AC-DC	25-12 Mo DC Lime, 25-12 Mo DC Titania	25-12 Mo AC-DC	-	25-20 DC Lime, 25-20 DC Titania	25-20 AC-DC
Metal & Thermit Corp.	Murex 308-15	Murex 308-16	-	Murex 308ELC-16	Murex 309-15	Murex 309-16	-	Murex 309Cb-16	-	-	-	Murex 310-15	Murex 310-16
Morris, Wheeler & Co., Inc.	MorWeld 95	MorWeld 95 AC	MorWeld 95 ELC	MorWeld 95 ELC-AC	MorWeld 98	MorWeld 98 AC	MorWeld 98 Cb	MorWeld 98 Cb-AC	MorWeld 98 Mo	MorWeld 98 Mo-AC	MorWeld 99	MorWeld 99 AC	MorWeld 99 AC
National Cylinder Gas Div. of Chemtron Corp.	Sureweld 308-15	Sureweld 308-16	Sureweld 308ELC-15	Sureweld 308ELC-16	Sureweld 309-15	Sureweld 309-16	Sureweld 309Cb-15	Sureweld 309Cb-16	Sureweld 309Mo-15	Sureweld 309Mo-16	-	Sureweld 310-15	Sureweld 310-16
Pacific Welding Alloys Mfg. Co.	Pacific E308-15	Pacific E308-16	Pacific E308ELC-15	Pacific E308ELC-16	Pacific E309-15	Pacific E309-16	Pacific E309Cb-15	Pacific E309Cb-16	Pacific E309Mo-15	Pacific E309Mo-16	-	Pacific E310-15	Pacific E-310-16
Perma-Latem Welding Alloys, Inc.	Perma-Latem 308 DC	Perma-Latem 308 AC-DC	-	-	Perma-Latem 309 DC	Perma-Latem 309 AC-DC	-	-	-	-	-	Perma-Latem 310 DC	Perma-Latem 310 AC-DC
Reid-Avery Co., Inc.	Racalloy 18-8 DC	Racalloy 18-8 AC-DC	Racalloy 18-8 ELC DC	Racalloy 18-8 ELC AC-DC	Racalloy 25-12 DC	Racalloy 25-12 AC-DC	Racalloy 25-12Cb DC	Racalloy 25-12Cb AC-DC	Racalloy 25-12Mo DC	Racalloy 25-12Mo AC-DC	-	Racalloy 25-20 DC	Racalloy 25-20 AC-DC
Shober Sales, Inc.	Shober 308-15	Shober 308-16	Shober 308ELC-15	Shober 308ELC-16	Shober 309-15	Shober 309-16	Shober 309Cb-15	Shober 309Cb-16	Shober 309Mo-15	-	-	Shober 310-15	Shober 310-16
A. O. Smith Corp.	SW 308 DC Lime, SW308DC Titania	SW 308 AC-DC	SW 308 ELC DC Lime, SW 308 ELC DC Titania	SW 308 ELC AC-DC	SW 309 DC Lime, SW 309 DC Titania	SW 309 AC-DC	SW 309Cb DC Lime	SW 309Cb AC-DC	SW 309Mo DC Lime, SW 309Mo DC Titania	SW 309Mo AC-DC	-	SW 310 DC Lime, SW 310 DC Titania	SW 310 AC-DC
Southern Oxygen Co., Inc.	SOCO E308-15	SOCO E308-16	SOCO E308ELC-15	SOCO E308ELC-16	SOCO E309-15	SOCO E309-16	SOCO E309Cb-15	SOCO E309Cb-16	SOCO E309Mo-15	SOCO E309Mo-16	-	SOCO E310-15	SOCO E310-16
Steel Sales Corp.	E308-15	E308-16	E308ELC-15	E308ELC-16	E309-15	E309-16	E309Cb-15	E309Cb-16	E309Mo-15	E309Mo-16	-	E310-15	E310-16
Victor Equipment Co.	VW308 Lime	VW308 AC-DC	VW308ELC Lime	VW308ELC AC-DC	VW309 Lime	VW309 AC-DC	VW309Cb Lime	VW309Cb AC-DC	-	-	-	VW310 Lime	VW310
Westinghouse Electric Corp.	308-15	308-16	E308ELC-15	E308ELC-16	309-15	309-16	309Cb-15	309Cb-16	-	-	-	310-15	310-16

Par. 6.1.3.2 Table 2

Table 2

Covered STAINLESS STEEL Electrodes

Manufacturers	AWS-ASTM Classification	E310Cb-15	E310Cb-16	E310Mo-15	E310Mo-16	E312-15	E312-16	E316-15	E316-16	E316ELC-15	E316ELC-16	E317-15	E317-16
Air Reduction Sales Co.		Airco 25-20Cb DC	Airco 25-20Cb AC-DC	Airco 25-20Mo DC	Airco 25-20Mo AC-DC	Airco 29-9 DC	Airco 29-9 AC-DC	Airco 18-12Mo DC	Airco 18-12Mo AC-DC, Easyarc 316 AC-DC	-	Airco 18-12Mo ELC AC-DC	-	Airco 18-12 3.5 Mo AC-DC
Alloy Rods Co.		Arcaloy Type 310Cb Lime	Arcaloy Type 310Cb AC-DC	Arcaloy Type 310Mo Lime	Arcaloy Type 310Mo AC-DC	Arcaloy Type 312 Lime	Arcaloy Type 312 AC-DC	Arcaloy Type 316 Lime	Arcaloy Type 316 AC-DC	Arcaloy Type 316ELC Lime	Arcaloy Type 316ELC AC-DC	Arcaloy Type 317 Lime	Arcaloy Type 317 AC-DC
Arcos Corp.		Chromend 25/20Cb	-	Chromend 25/20Mo	-	Chromend 29/9	Stainlend 29/9	Chromend KMo, Aerocor 316, Fabricor 316	Stainlend KMo	Chromend KMoLC	Stainlend KMoLC	Chromend 18/8Mo	Stainlend 18/8Mo
Canadian Liquid Air Co., Ltd.		Arcaloy 310Cb Lime	Arcaloy 310Cb AC-DC	Arcaloy 310Mo Lime	Arcaloy 310Mo AC-DC	Arcaloy 312 Lime	Arcaloy 312 AC-DC	Arcaloy 316 Lime	Arcaloy 316 AC-DC	Arcaloy 316ELC Lime	Arcaloy 316ELC AC-DC	Arcaloy 317 Lime	Arcaloy 317 AC-DC
Champion Rivet Co.		310Cb-1	310Cb-2	310Mo-1	310Mo-2	312-1	312-2	316-1	316-2	316 CF-1	316 CF-2	317-1	317-2
Eutectic Welding Alloys Corp.		-	-	-	-	-	-	-	Staintrode A Mo AC-DC	-	-	-	Staintrode B Mo AC-DC
Gases Agonex, S. A.		-	Murex 310Cb	-	Murex 310Mo	-	Murex 312	-	Murex 316	-	-	-	Murex 317
Harnischfeger Corp.		Harstain 25-20 Cb	Harstain *A* 25-20 Cb	Harstain 25-20 Mo	Harstain *A* 25-20 Mo	Harstain Type 312	Harstain *A* Type 312	Harstain 18-8-2Mo	Harstain *A* 18-8-2Mo	Harstain 18-8-2Mo ELC	Harstain *A* 18-8-2Mo ELC	Harstain 18-8-3Mo	Harstain *A* 18-8-3Mo
Hobart Brothers Co.		310Cb DC	310Cb AC	310Mo DC	310Mo AC	312 DC	312 AC	316 DC	316 AC	316 ELC DC	316 ELC AC	317 DC	317 AC
Morquette Mfg., Co., Inc.		-	No. 310Cb	-	No. 310Mo	-	No. 312	-	No. 316	-	No. 316ELC	-	-
Maurath, Inc.		Maurath E-310-Cb-15	Maurath E-310-Cb-16	Maurath E-310-Mo-15	Maurath E-310-Mo-16	-	-	Maurath E-316-15	Maurath E-316-16	-	-	Maurath E-317-15	Maurath E-317-16
McKay Co.		25-20Cb DC Lime, 25-20Cb DC Titania	25-20Cb AC-DC	25-20Mo DC Lime, 25-20Mo DC Titania	25-20Mo AC-DC	29-9 DC Lime, 29-9 DC Titania	29-9 AC-DC	18-8Mo(316) DC Lime, 18-8Mo(316) DC Titania	18-8Mo(316) AC-DC	18-8Mo ELC (316 ELC) DC Lime, 18-8Mo ELC (316 ELC) DC Titania	18-8Mo ELC (316 ELC) AC-DC	18-8Mo(317) DC Lime, 18-8Mo(317) DC Titania	18-8Mo(317) AC-DC
Metal & Thermit Corp.		Murex 310Cb-15	Murex 310Cb-16	-	Murex 310Mo-16	Murex 312-15	Murex 312-16	Murex 316-15	Murex 316-16	-	-	-	Murex 317-16
Morris, Wheeler & Co., Inc.		MorWeld 99 Cb	MorWeld 99 Cb-AC	MorWeld 99 Mo	MorWeld 99 Mo-AC	MorWeld 192	MorWeld 192 AC	MorWeld 96	MorWeld 96 AC	MorWeld 96 ELC	MorWeld 96 ELC-AC	MorWeld 193	MorWeld 193 AC
National Cylinder Gas Div. of Chemetron Corp.		Sureweld 310Cb-15	Sureweld 310Cb-16	Sureweld 310Mo-15	Sureweld 310Mo-16	Sureweld 312-15	Sureweld 312-16	Sureweld 316-15	Sureweld 316-16	Sureweld 316ELC-15	Sureweld 316ELC-16	Sureweld 317-15	Sureweld 317-16
Pacific Welding Alloys Mfg. Co.		Pacific E310Cb-15	Pacific E310Cb-16	Pacific E310Mo-15	Pacific E310Mo-16	Pacific E312-15	Pacific E312-16	Pacific E316-15	Pacific E316-16	Pacific E316ELC-15	Pacific E316ELC-16	Pacific E317-15	Pacific E317-16
Perma-Latem Welding Alloys, Inc.		-	-	-	-	-	-	Perma-Latem 316 DC	Perma-Latem 316 AC-DC	-	-	-	-
Reid-Avery Co., Inc.		Racollo 310Cb 25-20Cb DC	Racollo 310Cb 25-20Cb AC-DC	Racollo 310Mo 25-20Mo DC	Racollo 310Mo 25-20Mo AC-DC	Racollo 312 29-9 DC	Racollo 312 29-9 AC-DC	Racollo 316 18-12 DC	Racollo 316 18-12 AC-DC	Racollo 316 ELC 18-12 ELC DC	Racollo 316 ELC 18-12 ELC AC-DC	Racollo 317 18-12-3Mo DC	Racollo 317 18-12-3Mo AC-DC
Shober Sales, Inc.		Shober 310Cb-15	Shober 310Cb-16	Shober 310Mo-15	Shober 310Mo-16	Shober 312-15	Shober 312-16	Shober 316-15	Shober 316-16	Shober 316ELC-15	Shober 316ELC-16	Shober 317-15	Shober 317-16
A. O. Smith Corp.		SW 310Cb DC Lime	SW 310Cb AC-DC	SW 310Mo DC Lime	SW 310Mo AC-DC	SW 312 DC Lime	SW 312 AC-DC	SW 316 DC Lime, SW 316 DC Titania	SW 316 AC-DC	SW 316ELC DC Lime, SW 316ELC DC Titania	SW 316ELC AC-DC	SW 317 DC Lime, SW 317 DC Titania	SW 317 AC-DC
Southern Oxygen Co., Inc.		SOCO E310Cb-15	SOCO E310Cb-16	SOCO E310Mo-15	SOCO E310Mo-16	SOCO E312-15	SOCO E312-16	SOCO E316-15	SOCO E316-16	SOCO E316ELC-15	SOCO E316ELC-16	SOCO E317-15	SOCO E317-16
Steel Sales Corp.		E310Cb-15	E310Cb-16	E310Mo-15	E310Mo-16	E312-15	E312-16	E316-15	E316-16	E316ELC-15	E316ELC-16	E317-15	E317-16
Victor Equipment Co.		VW310Cb Lime	VW310Cb AC-DC	VW310Mo Lime	VW310Mo AC-DC	VW312 Lime	VW312 AC-DC	VW316 Lime	VW316 AC-DC	VW316ELC Lime	VW316ELC AC-DC	VW317 Lime	VW317 AC-DC
Westinghouse Electric Corp.		310Cb-15	310Cb-16	310Mo-15	310Mo-16	312-15	312-16	316-15	316-16	316ELC-15	316ELC-16	317-15	317-16

Table 3

Par. 6.1.3.2 Table 3

## Covered STAINLESS STEEL Electrodes

Manufacturers	AWS-ASTM Classification	E318-15	E318-16	E330-15	E330-16	E347-15	E347-16	E410-15	E410-16	E430-15	E430-16	E502-15	E502-16
Air Reduction Sales Co.		-	-	Airco 15Cr 35Ni DC	Airco 15Cr 35Ni AC-DC	Airco 19-9Cb DC	Airco 19-9Cb AC-DC, Easyarc 347-AC-DC	Airco 12Cr DC	-	Airco 16Cr	-	Airco 4-6Cr Mo DC	-
Alloy Rods Co.		Arcaloy Type 318 Lime	Arcaloy Type 318 AC-DC	Arcaloy Type 330 Lime	Arcaloy Type 330 AC-DC	Arcaloy Type 347 Lime	Arcaloy Type 347 AC-DC	Arcaloy Type 410 Lime	Arcaloy Type 410 AC-DC	Arcaloy Type 430 Lime	Arcaloy Type 430 AC-DC	Arcaloy Type 502 Lime	Arcaloy Type 502 AC-DC
Arcos Corp.		Chromend KMo-Cb	Stainlend KMo-Cb	Chromend 15/35	-	Chromend 19/9Cb, Aerocor 347, Fabricor 347	Stainlend 19/9Cb	Chromend 12, Aerocor 410	Stainlend 12	Chromend 16	-	Chromend 5M	-
Canadian Liquid Air Co., Ltd.		Arcaloy 318 Lime	Arcaloy 318 AC-DC	Arcaloy 330 Lime	Arcaloy 330 AC-DC	Arcaloy 347 Lime	Arcaloy 347 AC-DC	Arcaloy 410 Lime	Arcaloy 410 AC-DC	Arcaloy 430 Lime	Arcaloy 430 AC-DC	Arcaloy 502 Lime	Arcaloy 502 AC-DC
Champion Rivet Co.		318-1	318-2	330-1	330-2	347-1	347-2	410-1	410-2	430-1	430-2	Croloy 5A	502-2
Eutetic Welding Alloys Corp.		-	-	-	-	-	Staintrade A AC-DC	-	-	-	-	-	-
Gases Agmex, S. A.		-	-	-	Murex 330	-	Murex 347	Murex 410	-	Murex 430	-	Murex 502	-
Hornischfeger Corp.		-	-	-	-	Harstain 18-8Cb	Harstain "A" 18-8Cb	-	-	Harchrome 16	-	Harchrome 5	-
Hobart Brothers Co.		318 DC	318 AC	330 DC	330 AC	347 DC	347 AC	410 DC	410 AC	430 DC	430 AC	502 DC	502 AC
Lincoln Electric Co.		Stainweld C-Cb	-	-	-	Stainweld A5-Cb	Stainweld A7-Cb	-	-	-	-	-	-
Marquette Mfg. Co., Inc.		-	No. 318	-	No. 330	-	No. 347	-	No. 410	-	No. 430	-	No. 502
Maurath, Inc.		Maurath E-318-15	Maurath E-318-16	Maurath E-330-15	Maurath E-330-16	Maurath E-347-15	Maurath E-347-16	Maurath E-410-15	Maurath E-410-16	Maurath E-430-15	Maurath E-430-16	Maurath E-502-15	Maurath E-502-16
McKey Co.		18-8Mo Cb DC Lime, 18-8Mo Cb DC Titania	18-8Mo Cb AC-DC	15-35 DC Lime, 15-35 DC Titania	15-35 AC-DC	18-8Cb DC Lime, 18-8Cb DC Titania	18-8Cb AC-DC	12Cr DC Lime	12Cr AC-DC	15Cr DC Lime	16Cr AC-DC	5CrMo DC-Lime	5CrMo AC-DC
Metal & Thermit Corp.		-	-	Murex 330-15	Murex 330-16	Murex 347-15	Murex 347-16	Murex 410-15	-	Murex 430-15	-	Murex 502-15, Murex Croloy 5A, 7A, 9A	-
Morris, Wheeler & Co., Inc.		MorWeld 191	MorWeld 191 AC	MorWeld 195	MorWeld 195 AC	MorWeld 27	MorWeld 97 AC	MorWeld 106	MorWeld 106 AC	MorWeld 197	MorWeld 197 AC	MorWeld 198	MorWeld 198 AC
National Cylinder Gas Div. of Chemtron Corp.		Sureweld 318-15	Sureweld 318-16	Sureweld 330-15	Sureweld 330-16	Sureweld 347-15	Sureweld 347-16	Sureweld 410-15	Sureweld 410-16	Sureweld 430-15	Sureweld 430-16	Sureweld 502-15	Sureweld 502-16
Pacific Welding Alloys Mfg. Co.		Pacific E318-15	Pacific E318-16	Pacific E330-15	Pacific E330-16	Pacific E347-15	Pacific E347-16	Pacific E410-15	Pacific E410-16	Pacific E430-15	Pacific E430-16	Pacific E502-15	Pacific E502-16
Perma-Latem Welding Alloys, Inc.		-	-	-	-	Perma-Latem 347 DC	Perma-Latem 347 AC-DC	-	-	-	-	-	-
Reid-Avery Co., Inc.		Raccolloy 318 18-8 Mo Cb DC	Raccolloy 318 18-8 Mo Cb AC-DC	Raccolloy 330 15-35 DC	Raccolloy 330 15-35 AC-DC	Raccolloy 347 18-8Cb DC	Raccolloy 347 18-8Cb AC-DC	Raccolloy 410 12Cr Mo DC	Raccolloy 410 12Cr Mo AC-DC	Raccolloy 430 430-DC	Raccolloy 430 430 AC-DC	Raccolloy 502 5Cr Mo DC	Raccolloy 502 5 Cr Mo AC-DC
Shober Sales, Inc.		Shober 318-15	Shober 318-16	Shober 330-15	Shober 330-16	Shober 347-15	Shober 347-16	Shober 410-15	Shober 410-16	Shober 430-15	Shober 430-16	Shober 502-15	Shober 502-16
A. O. Smith Corp.		SW 318 DC Lime	SW 318 AC-DC	SW 330 DC Lime, SW 330 DC Titania	SW 330 AC-DC	SW 347 DC Lime, SW 347 DC Titania	SW 347 AC-DC	SW 410 DC Lime	SW 410 AC-DC	SW 430 DC Lime	SW 430 AC-DC	SW 502 DC Lime, SW 151 DC Lime	-
Southern Oxygen Co., Inc.		SOCO E318-15	SOCO E318-16	SOCO E330-15	SOCO E330-16	SOCO E347-15	SOCO E347-16	SOCO E410 Lime	SOCO E410 AC-DC	SOCO E430 Lime	SOCO E430 AC-DC	SOCO E502 Lime	SOCO E502 AC-DC
Steel Sales Corp.		E318-15	E318-16	E330-15	E330-16	E347-15	E347-16	E410-15	E410-16	E430-15	E430-16	E502-15	E502-16
Victor Equipment Co.		VW318 Lime	VW318 AC-DC	VW330 Lime	VW330 AC-DC	VW347 Lime	VW347 AC-DC	VW410 Lime	VW410 AC-DC	VW430 Lime	VW430 AC-DC	VW502 Lime	VW502 AC-DC
Westinghouse Electric Corp.		318-15	318-16	330-15	-	347-15	347-16	410-15	410-16	430-15	430-16	502-15	-

Table 4

**DEFO STAINLESS STEEL Welding Rods and Electrodes**

SEE TENTATIVE SPECIFICATIONS FOR CORROSION-RESISTING CHROMIUM AND CHROMIUM-NICKEL STEEL WELDING RODS AND BARE ELECTRODES.  
(AWS A 5.9-53; ASTM A 371-53)

Manufacturers	AWS-ASTM Classification	ER308	ER308L	ER309	ER310	ER316	ER316L	ER317	ER330	ER347	ER410	ER420	ER430	ER502
Air Reduction Sales Co.	Airco 308, Aircomatic A308	Airco 308 ELC, Aircomatic A308ELC	Airco 309, Aircomatic A309	Airco 310, Aircomatic A310	Airco 316, Aircomatic A316	Airco 316 ELC, Aircomatic A316ELC	-	Airco 330	Airco 347, Aircomatic A347	Airco 410	-	Airco 430	Airco 502, Aircomatic A502	
Allegheny Ludlum Steel Corp.	308	308L	309	310	316	316L	317	330	347	410	420	430	502	
American Chain & Cable Co., Inc. Page Steel and Wire Div.	Page-308	Page-308 ELC	Page-309	Page-310	Page-316	Page-316 ELC	-	-	Page-347	Page-410	Page-420	Page-430	Page-502	
Arcos Corp.	Chromenar K	Chromenar K-LC	Chromenar HC	Chromenar HCN	Chromenar KMo	Chromenar KMo-LC	-	Chromenar 15/35	Chromenar 19/9Cb	Chromenar 12	Chromenar 12C	Chromenar 16	Chromenar 5M	
Canadian Liquid Air Co., Ltd.	Type 308	Type 308 ELC	Type 309	Type 310	Type 316	Type 316 ELC	-	-	Type 347	Type 410	-	Type 430	Type 502	
Champion Rivet Co.	Type 308	Type 308 CF	Type 309	Type 310	Type 316	Type 316 CF	Type 317	Type 330	Type 347	Type 410	-	Type 430	Type 502	
Collins-Edmonds, Inc.	C-E 308	C-E 308 ELC	C-E 309	C-E 310	C-E 316	C-E 316 ELC	C-E 317	C-E 330	C-E 347	C-E 410	C-E 420	C-E 430	C-E 502	
Drawalloy Corp.	Drawalloy Type 308	Drawalloy Type 308 ELC	Drawalloy Type 309	Drawalloy Type 310	Drawalloy Type 316	Drawalloy Type 316 ELC	-	-	Drawalloy Type 347	Drawalloy Type 410	-	Drawalloy Type 430	Drawalloy Type 502	
Eutectic Welding Alloys Corp.	-	-	-	-	-	-	-	-	Stainrod A GAS	-	-	-	-	
Gases Agamex, S. A.	-	-	-	-	Inoxidable AGA	-	-	-	-	-	-	-	-	
Hobart Brothers Co.	R308	R308ELC	R309	R310	R316	R316ELC	-	R330	R347	R410	R420	R430	R502	
Johnston Stainless Welding Rods, Inc.	Johnston Type 308	Johnston Type 308L	Johnston Type 309	Johnston Type 310	Johnston Type 316	Johnston Type 316 L	Johnston Type 317	Johnston Type 330	Johnston Type 347	Johnston Type 410	Johnston Type 420	Johnston Type 430	Johnston Type 502	
Lincoln Electric Co.	Lincolnweld L-18-8	-	-	-	-	-	-	-	-	-	-	-	-	
Linde Co.	Oxweld 308	Oxweld 308L	Oxweld 309	Oxweld 310	Oxweld 316 U-316CbTa	Oxweld 316L	-	-	Oxweld 60, 28 U-347	Oxweld 410	Oxweld 420	Oxweld 430	Oxweld 502	
Marquette Mfg. Co. Inc.	No. G-308	-	-	-	-	-	-	-	-	-	-	-	-	
Maurath, Inc.	Maurath ER-308	-	Maurath ER-309	Maurath ER-310	Maurath ER-316	-	Maurath ER-317	Maurath ER-330	Maurath ER-347	Maurath ER-410	-	Maurath ER-430	Maurath ER-502	
McKay Co.	308	308 ELC	309	310	316	316 ELC	317	330	347	410	420	430	502	
Metal & Thermit Corp.	Murex 308	Murex 308-L	Murex 309	Murex 310	Murex 316	Murex 316-L	Murex 317	Murex 330	Murex 347	Murex 410	Murex 420	Murex 430	Murex 502	
Morris, Wheeler & Co., Inc.	MorWeld 47	-	-	-	MorWeld 47A	-	-	-	MorWeld 48	-	-	-	-	
National Cylinder Gas Div. of Chemtron Corp.	NCG No. 120, 301	NCG No. 311	NCG No. 321	NCG No. 341	-	-	-	-	NCG No. 351	-	-	-	-	
Pacific Welding Alloys Mfg. Co.	Pacific 308	Pacific 308L	Pacific 309	Pacific 310	Pacific 316	Pacific 316L	Pacific 317	Pacific 330	Pacific 347	Pacific 410	Pacific 420	Pacific 430	Pacific 502	
Perma-Latem Welding Alloys, Inc.	Perma-Loy G308	Perma-Loy G308L	Perma-Loy G309	Perma-Loy G310	Perma-Loy G316	Perma-Loy G316L	Perma-Loy G317	Perma-Loy G330	Perma-Loy G347	Perma-Loy G410	Perma-Loy G420	Perma-Loy G430	Perma-Loy G502	
Reid-Avery Co., Inc.	Racolloy 308	Racolloy 308 ELC	Racolloy 309	Racolloy 310	Racolloy 316	Racolloy 316 ELC	Racolloy 317	Racolloy 330	Racolloy 347	Racolloy 410	Racolloy 420	Racolloy 430	Racolloy 502	
A. D. Smith Corp.	Type 308	Type 308 ELC	Type 309	Type 310	Type 316	Type 316 ELC	-	Type 330	Type 347	Type 410	-	Type 430	Type 502	
Southern Oxygen Co., Inc.	SOCO 308 Bare	-	-	-	SOCO 316	-	-	-	SOCO 347 Bare	-	-	-	-	
Steel Sales Corp.	Bare Type 308	-	-	-	-	-	-	-	-	-	-	-	-	
Westinghouse Electric Corp.	SS308	SS308ELC	SS309	SS310	SS316	SS316ELC	-	-	SS347	SS410	-	SS430	-	

### 6.1.3.3 Weld Metal Composition vs. Base Metal Composition

Table 1 lists types of welding rods and electrodes that can be employed to join the various stainless steel grades to themselves, to other stainless steel grades, and to carbon steel.

Where more than one welding electrode composition is listed, the listing is in order of preference, taking into consideration factors such as corrosion resistance, tendency toward cracking, cost, ease of procurement, and tensile strength. Welding procedure is extremely important, especially in the case of welding the various stainless steels to carbon steel. It is recommended that all stainless steel to carbon steel welding procedures be prepared by persons who are familiar with the problems that can result from improper procedures.

The electrode compositions in Table 1 that are followed by an asterisk (\*) are not listed in A.S.T.M. A298-55T or A.S.T.M. A371-53T as standard welding rods or electrodes (See Par. 6.1.3.1). They can be obtained on special order, but are not always retained in stock. When ordering non-standard welding rods or electrodes of the columbium stabilized grades, the composition must be specified so that the elements are balanced to give sufficient ferrite in the deposited metal to minimize the tendency toward cracking.

Table 1  
STAINLESS STEEL GRADES TO BE JOINED

	202,301 302,304	304L	309	309S	309Scb	310	316	316L	317	317L	321	347	Carbon Steel
202,301, 302,304													
		308	308	308	309S*	310	308	316L	308	317L*	308	308	309
		308L	308L	308L	309S*	310	316	316L	317	317L*	347	347	310
		308L	308L	308L	309S*	310	308	308L	308L	308L	308L	308L	309
		308L	308L	308L	309S*	310	316	316L	317	317L*	347	347	310
304L		308	308	308	308L	308L	308	308L	308L	308L	308L	308L	309
		308L	308L	308L	309S*	310	316	316L	317	317L*	347	347	310
309		309	309	309	309S*	310	309	309	309	309	309	309	309
		309	309	309	309S*	310	316	316L	317	317L*	347	347	310
309S		309S*	309S*	309S*	309S*	309S*	309S*	309S*	309S*	309S*	309S*	309S*	309S*
		309S*	309S*	309S*	309S*	310	316	316L	317	317L*	347	347	310
		309S*	309S*	309S*	309S*	310	309S*	309S*	309S*	309S*	309S*	309S*	309S*
309Scb		309S*	309S*	309S*	309S*	310	309S*	309S*	309S*	309S*	309S*	309S*	309S*
		309S*	309S*	309S*	309S*	310	316	316L	317	317L*	347	347	310
		309S*	309S*	309S*	309S*	310	309S*	309S*	309S*	309S*	309S*	309S*	309S*
310		310	310	310	310	310	310	310	310	310	310	310	310
		310	310	310	310	310	310	310	310	310	310	310	310
316		316	316	316	316	316	316	316	316	316	316	316	316
		316	316	316	316	316	316	316	316	316	316	316	316
316L		316L	316L	316L	316L	316L	316L	316L	316L	316L	316L	316L	316L
		316L	316L	316L	316L	316L	316L	316L	316L	316L	316L	316L	316L
317		317	317	317	317	317	317	317	317	317	317	317	317
		317	317	317	317	317	317	317	317	317	317	317	317
317L		317L	317L	317L	317L	317L	317L	317L	317L	317L	317L	317L	317L
		317L	317L	317L	317L	317L	317L	317L	317L	317L	317L	317L	317L
321		321	321	321	321	321	321	321	321	321	321	321	321
		321	321	321	321	321	321	321	321	321	321	321	321
347		347	347	347	347	347	347	347	347	347	347	347	347
		347	347	347	347	347	347	347	347	347	347	347	347

← COMPOSITION OF WELDING RODS OR ELECTRODES →

6.1.3.4

6.1.3.4 N.E.M.A. COLOR CODES FOR WELDING  
RODS AND ELECTRODES

The information in this section was reproduced from NEMA Standards EW 2-1959 and EW 3-1958.

## NEMA STANDARD FOR IDENTIFICATION OF COVERED ARC-WELDING ELECTRODES

(NEMA Standard 9-25-1963.)

Arc-welding electrodes of the types listed in Tables I through VIII, inclusive, shall be identified either by imprinting as set forth in Part 1 or by applying the color markings set forth in Part 2.

### Part 1 IDENTIFICATION OF COVERED ELECTRODES BY IMPRINTING

When covered electrodes are identified by imprinting, the imprinting shall be applied as follows:

1. At least two legible electrode type designation markings shall be applied to the electrode covering in such a manner that at least one complete type designation shall come within the space 2 1/2 inches from the grip end of the electrode.
2. The number and letters of the electrode type designation shall be of bold block type and of sufficient size to be readable.
3. The ink used shall provide sufficient contrast with the electrode covering so that the letters and numbers of the electrode type designation shall be readable before and after normal welding applications.
4. For electrode type designations employing the prefix letter E or prefix letters Mil, such prefix letter or letters shall be omitted from the electrode type designation imprinted in the electrode coating.

### Part 2 IDENTIFICATION OF COVERED ELECTRODES BY COLOR MARKING

When covered electrodes are identified by color marking, the colors shall be applied in accordance with Tables I to VIII.

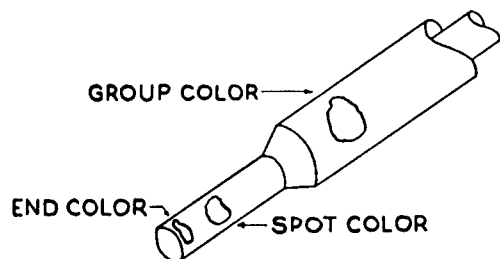

Fig. 1

Location of Color Markings for End-grip Electrodes

NOTE I—In the case of center-grip electrodes, the end color will be centrally located, and the spot color will be located on each side of the end color.

NOTE II—Color references in Fig. 1 and 2 are used only to denote sequence of colors; they are not intended to show the configuration of the colors to be applied.

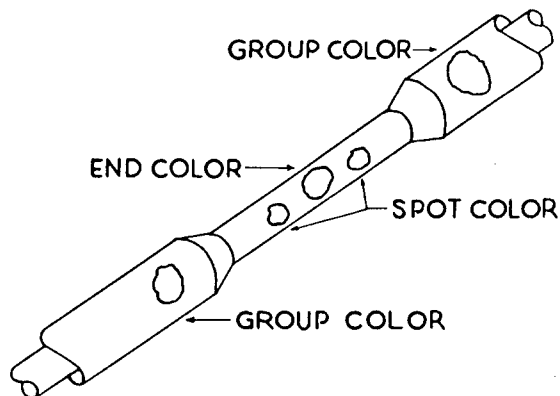

Fig. 2

Location of Color Markings for Center-grip Electrodes

Table 1  
 COLOR IDENTIFICATION FOR COVERED CHROMIUM AND CHROMIUM-NICKEL STEEL ELECTRODES  
 DIRECT CURRENT

		Group Color — Black												
End Color	No Color	Blue	White	Brown	Green	Red	Yellow	Black	Orange	Violet	Gray	Bronze	Silver	
Spot Color	No Color	Blue	White	Brown	Green	Red	Yellow	Black	Orange	Violet	Gray	Bronze	Silver	
No Color	Mil 308 MoL-15 Mil 308 MoT-15			E308LC-15	E330-15	E310-15	E308-15	E309-15						
Blue				Mil 202 LC-15		E310Cb-15	E347-15	E309Cb-15			E502-15			
White				E316LC-15		E310Mo-15	E316-15	E309Mo-15			9Cr-1Mo (Type 505)			
Brown						20-29+ Ca+Mo	E317-15				E410-15			
Green							E318-15				E430-15			
Red					E312-15		Mil 308 HC-15				18Cr (Type 442)			
Yellow							Mil 347 HC-15				28Cr (Type 446)			
Black	Mil 307 L-15 Mil 307 T-15				15-35HC (Type 330HC)									
Orange														
Violet														
Gray														
Bronze														
Silver														
							19-9WMo (Type 3/9)							

NOTE I—Type numbers are those of the American Iron and Steel Institute. The weld analysis nearest to that specified by AISI is the one used here for reference.  
 NOTE II—AWS classification numbers refer to electrodes in the AWS-ASTM Tentative Specifications for Corrosion-Resisting Chromium and Chromium-Nickel Steel Covered Welding Electrodes, AWS A 5.4, ASTM A 298.  
 NOTE III—Mil type numbers refer to electrodes in military specifications.

Table 2

COLOR IDENTIFICATION FOR COVERED CHROMIUM AND CHROMIUM-NICKEL STEEL ELECTRODES  
ALTERNATING AND DIRECT CURRENT

		Group Color — Yellow											
End Color	No Color	Blue	White	Brown	Green	Red	Yellow	Black	Orange	Violet	Gray	Bronze	Silver
Spot Color	No Color												
No Color	MIL 308 Mo-L-16 MIL 308 Mo-T-16			E308LC-16	E330-16	E310-16	E308-16	E309-16					
Blue				MIL 202 LC-16		E310Cb-16	E347-16	E309Cb-16			E502-16		
White				E316LC-16		E310Mo-16	E316-16	E309Mo-16			9Cr-1Mo (Type 505)		
Brown						20-29+ Cu+Mo	E317-16				E410-16		
Green							E318-16				E430-16		
Red					E312-16		MIL 308 HC-16				18Cr (Type 442)		
Yellow		MIL 16.8.2- 16					MIL 347 HC-16				28Cr (Type 446)		
Black	MIL 307 L-16 MIL 307 T-16				15-35HIC (Type 330HFC)								
Orange													
Violet													
Gray													
Bronze													
Silver													
							19-9WMo (Type 339)						

NOTE I—Type numbers are those of the American Iron and Steel Institute. The weld analysis nearest to that specified by AISI is the one used here for reference.  
NOTE II—AWS classification numbers refer to electrodes in the AWS-ASTM Tentative Specifications for Corrosion-Resisting Chromium and Chromium-Nickel Steel Covered Welding Electrodes, AWS A 5.4, ASTM A 298.  
NOTE III—MIL type numbers refer to electrodes in military specifications.

FIG. 2  
NEMA STANDARD FOR IDENTIFICATION OF  
CUT-LENGTH BARE ARC-WELDING RODS AND ELECTRODES

(NEMA Standard 7-16-1958.)

All cut-length bare arc-welding rods and electrodes of the types listed in Tables I to V, inclusive, shall be identified either by applying the color markings specified in the tables or by imprinting on or indenting in the surface of the bare rod or electrode the American Welding Society (AWS) classification numbers.

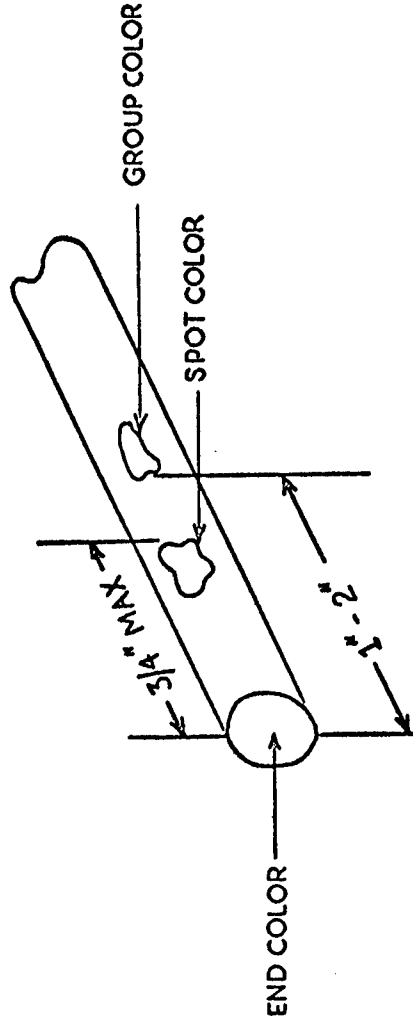

NOTE—Color references are used only to denote sequence of colors; they are not intended to show the configuration of the colors to be applied.

Table 3

COLOR IDENTIFICATION FOR BARE CHROMIUM AND CHROMIUM-NICKEL STEEL RODS AND ELECTRODES

		Group Color — Yellow												
End Color Spot Color	No Color	Blue	White	Brown	Green	Red	Yellow	Black	Orange	Violet	Gray	Bronze	Silver	
No Color				ER308L	ER330	ER310	ER308	ER309						
Blue							ER347				ER502			
White				ER316L			ER316							
Brown							ER317				ER410			
Green							Type 318				ER430			
Red					Type 312									
Yellow														
Black											ER420			
Orange							Type 349							
Violet														
Gray														
Bronze														
Silver														

NOTE I—Type numbers are those of the American Iron and Steel Institute. The weld analysis nearest to that specified by AISI is the one used here for reference.  
 NOTE II—AWS classification numbers refer to rods and electrodes in the AWS-ASTM Tentative Specifications for Corrosion-Resisting Chromium and Chromium-Nickel Steel Welding Rods and Bare Electrodes, AWS A 3.9-53E, ASTM A 371-55E.

## 6.1.4 Techniques

### 6.1.4.1 Tube to Tube Sheet Welds

#### 6.1.4.1.1 General

In the design of heat exchangers for extremely high pressures or for services where liquids contaminated with radioactive materials are handled, it is now common practice to consider welded tube to tube sheet joints to obtain the maximum insurance against leakage. Such welds may be seal welds or strength welds as required by the service conditions. There is no general agreement among users or fabricators of heat exchangers regarding the type of weld to be used and whether the tubes should be rolled into the tube sheet prior to welding, after welding, before and after welding, or not rolled at all. Consequently, even within the Du Pont Company, it will be found that different weld types of different combinations of the rolling and welding operations will be used for similar service conditions at different plants. This section will list types of tube to tube sheet welds now in general use and will list advantages or disadvantages of the various types.

#### 6.1.4.1.2 Seal Welds

Heat exchanger manufacturers generally prefer to use one of the seal welding methods. They are generally more adaptable to automatic welding processes, and since they are generally smaller in size than strength welds, cause less distortion of the tube sheet due to weld shrinkage stresses. It is customary in the case of seal welds to roll lightly prior to welding merely to obtain metal to metal contact between tube and tube hole generally without the use of a lubricant. Following the welding operation the tubes are frequently fully rolled.

Referring to Figure 1, Methods (a), (b), (c), (d), (e) and (f) show the commonly used seal welding methods. Comments on each method are listed below:

Methods (a) & (b) - These methods are essentially the same except for the chamfer shown in Method (a). The 1/16" projection in Method (a) is based on the use of 10 ga. tubes. The projection would be reduced somewhat for thinner tube walls. This would be one of the better seal welding methods where the tube sheet thickness is sufficient to resist the shrinkage stresses without objectionable distortion. Although this type of joint design cannot be guaranteed to produce a weld with strength equal to the tube strength, it will, as a rule, produce welds with greater penetration than with Methods (c) and (d). For typical weld penetration values with 10 ga. tubing, see Par. 6.1.4.1.5. This method would also be of value where, for weldability reasons, it is desirable to melt as little of the tube sheet material as possible. This method is suited to both automatic and manual welding methods. Method (a) should give more uniform weld penetration than method (b).

#### 6.1.4.1.2 - 6.1.4.1.3

Method (c) - This is the least reliable method for seal welding from the standpoint of weld metal penetration. It is suitable for automatic welding methods, where melting of equal portions of tube and tube sheet material can be tolerated from a metallurgical standpoint. As shown in Figure 1 Method (c), alternate method, a bead of weld metal can be deposited over the joint by the metal-arc process with coated electrodes or by the inert-gas shielded tungsten arc method with added filler metal. Where it is undesirable to fuse the tube and tube sheet material together because of the danger of cracking, the use of a filler rod of controlled ferrite content could reduce the possibility of cracking.

Method (d) - This method produces welds with penetration less than Methods (a) and (b). The welds made by this method do not project above the surface of the tube sheet. The method is suitable for automatic welding and would be advantageous, from a metallurgical standpoint where it is desirable to melt more of the tube sheet material than the tube material. The amount of weld penetration obtained by this joint design with 10 ga. tubing is indicated in Par. 6.1.4.1.5. Alternate Method (d) was used by Griscom-Russell (now Baldwin-Lima-Hamilton) where approx. .8T penetration is desired.

Methods (e) & (f) - This is known as a "low restraint" seal weld since the tube sheet distortion is greatly reduced over that resulting from the other seal welding methods. Although it is sometimes used as a strength weld, weld penetration equal to the tube wall thickness cannot be guaranteed. Method (f) covers the situation where it is desirable to roll the tube after welding. The tubes are slightly "belled" at the end so that weld overhang around the tube I.D. will not interfere with rolling. This is the best method from the standpoint of welding since sections of equal thickness are joined. This weld is made by both manual and automatic methods, usually without the addition of filler metal. With this method, there is the remote possibility of leakage through the rings machined around the holes if the tube sheet material contains laminations, or if the tube sheet material is crack sensitive.

#### 6.1.4.1.3 Strength Welds

Strength welds are normally employed for severe service conditions, such as those involving high temperatures, high pressures, containment of radioactive materials or other extremely hazardous or expensive materials. Other situations might include those where it is not desirable to fully roll tubes into tube sheets because of unfavorable hardness relationships. In the case of handling highly corrosive solutions the greater amount of weld metal resulting from the use of strength welds is advantageous.

Certain specifications require full rolling prior to welding with no rolling afterwards, others require light rolling prior to welding and full rolling afterwards, while others require light rolling prior to welding and no rolling afterwards. As shown in Par. 6.1.4.1.5, there is some slight advantage strengthwise to roll before and after welding, but this difference would not be sufficient in most cases to warrant the additional expense. A reason for fully rolling, either before or after welding, is to close the crevice between tube and tube sheet to prevent entry of a corrosive liquid contained on the shell side of a heat exchanger. When a corrosive liquid is contained on the tube side of a heat exchanger, a fully rolled joint would provide an additional barrier in the event of leakage through the weld. When fully rolling without lubricants prior to welding, there are frequently difficulties from roller breakage. In the case of thin tube sheets, the heat of welding could cause the rolled joint to leak in service. When fully rolling after welding, the weld could be damaged by the lengthwise expansion of the tube. Reaming is usually required prior to rolling after welding.

The drawings in Figure 1 (g), (h), (i), (j), (k), (l), and (m) show strength weld types. Comments are listed below:

Method (g) - This is the simplest strength welding method, involving only the deposition of a fillet weld of suitable size by manual welding methods. Some disadvantages include (1) inability to use automatic welding methods, (2) length of tubing projecting beyond face to tube sheet, and (3) possibility of welding operator failing to secure penetration into corner between tube and tube sheet. This is a low cost method in that no special tube sheet preparation is involved.

Method (h) - This is a variation of the fillet welding method described in (g) above. This method enjoys considerable usage in the fabrication of steam generators for nuclear powered vessels for the Navy. Welding is performed by automatic methods. Very close control of dimensions and welding machine settings are required for consistent weld metal penetration of the required dimension. This method would probably cause less tube sheet distortion of tube sheets than the other strength welding methods.

Method (i) - This method employs the "J" groove. By making the groove the same depth as the tube wall thickness and sufficiently wide to permit the welder to secure penetration at the root of the weld, control of weld metal penetration is not difficult. Distortion of thin tube sheets would be a problem with this weld method. This is the best strength weld method for manual welding.

Method (j) - This is a variation of the basic "J" groove weld. The principal advantage would be to permit the use of smaller ligaments between tubes.

#### 6.1.4.1.3 - 6.1.4.1.4

Method (k) - This method is a variation of the basic "J" groove method and is well suited to corrosive applications where it is desirable to cover the end of the tube to prevent end grain attack. Projection beyond the face of the tube sheet is less than with Methods (i) and (j).

Method (l) - This method involves recessing the tube below the surface of the tube sheet by an amount at least equal to the wall thickness of the tubing and depositing weld metal on the end of the tube until the weld penetration equals the tube wall thickness. Some disadvantages of this method include (1) the possibility of weld metal extending beyond the tube I.D. and causing difficulties with subsequent rolling operations and (2) the tubes on one end of a bundle would have to be trimmed after rolling to insure the proper depth below the tube sheet surface. Advantages would include (1) minimum penetration beyond the tube sheet surface and (2) no special machining required on tube sheet. It is understood that some shops insert a copper rod in the tube hole and deposit the weld with a titania coated metal arc welding electrode to prevent protrusion of weld metal beyond the tube I.D. This weld and Method (m) are not as suitable for high pressure and cyclic temperature conditions as the other strength weld types.

Method (m) - This is a variation of the recessed tube design described in (l) above. In this design, the possibility of weld protrusion beyond the tube I.D. is minimized and the position is slightly more favorable for welding.

#### 6.1.4.1.4 Welds for Special Applications

Certain applications require tube to tube sheet joints of types not covered by the conventional seal weld and strength weld types. Some welds for special applications are described below:

Method (n) - This weld type was developed at Hanford for an application which involved exposure to a severely corrosive solution on the outside of the tubes. It was essential to eliminate the crevice between tube and tube sheet to avoid crevice attack. By providing a 1/8" clearance around the tube the crevice condition was eliminated. Further details can be found in the article listed as Reference 3, Par. 6.1.4.1.7.

Method (o) - This joint incorporates a seal weld with the balance of the joint back brazed. This joint was developed at Oak Ridge for a heat exchanger which was subjected to severe thermal cycling as well as corrosive conditions on the tube side. Prior to the use of back brazing, peripheral cracking of tube to tube sheet welds occurred during cyclic tests. Further details can be found in the article listed as Reference 2, Par. 6.1.4.1.7.

Method (p) - This type of weld joint was used by Grisco-Russell (now Baldwin-Lima-Hamilton) to fabricate certain types of heat exchangers. This is the only butt-weld type joint which is used in heat exchanger fabrication. By use of a small gamma-ray source, radiographs of reasonably good quality were made in 1-1/2 inch O.D. tube to tube sheet welds. This type of weld joint is normally made on single tube sheet units such as U-tube or bayonet type since the tube end fits into a recess in the tube sheet projection. This method has not been used on units with two tube sheets. This is probably the most expensive type of tube to tube sheet joint and would be warranted only where extremely severe corrosive conditions were present on the outside of the tubes.

Method (q) - This method utilizes the same equipment as Method (p). It has not been used in the fabrication of heat exchangers, but shows promise as a repair method.

Method (r) - This method involves overlaying a tube sheet with a crack resistant weld deposit; then machining in preparation for welding by the method illustrated or for other tube to tube sheet joints. This scheme would be useful for small heat exchangers for severe service conditions where the only tube sheet material available was fully austenitic and extremely crack sensitive during welding.

#### 6.1.4.1.5 Properties of Tube to Tube Sheet Joints

##### a. Strength

Tests on rolled and welded tube to tube sheet joints reported in the article listed as reference 3, Par. 6.1.4.1.7 are summarized below. The joint type was similar to Method (d), Par. 6.1.4.1.2. One inch O.D. x 12 ga. (0.109") type 304L tubing was used and was recessed 1/16" below the tube sheet surface. The weld was made by fusing the tube sheet material to the end of the tube without the addition of filler metal. Each strength range gives results for four samples except "welded only", in which case there were eight samples. The tube sheet thickness was 2".

<u>Method</u>	<u>Load at Fracture, Lb.</u>	<u>Calculated Tensile Stress in Tube at Failure, p.s.i.</u>
Welded only	18,750-19,500	68,000-70,500
Rolled only (no groove)	5,650- 9,300	20,500-33,700
Rolled only (with groove)	6,830-10,250	24,800-37,100
Rolled (no groove) & welded	18,900-19,650	68,500-71,300

6.1.4.1.5 - 6.1.4.1.6

<u>Method</u>	<u>Load at Fracture, Lb.</u>	<u>Calculated Tensile Stress in Tube at Failure, p.s.i.</u>
Rolled (with groove) & welded	18,650-19,450	67,600-70,500
Rolled (no groove), welded, rerolled	19,500-20,000	70,700-72,400
Rolled (with groove), welded, rerolled	19,600-21,100	71,000-76,400
Welded & rolled (no groove)	19,100-22,000	69,200-79,700
Welded & rolled (with groove)	18,950-21,150	68,700-76,500

b. Penetration

A comparison of Methods (a), (d), and (1), made by Du Pont gave the weld penetration values listed below. One inch O.D. x 10 Ga. (.134) tubes were used.

<u>Method (a):</u>	Average penetration for eight tubes	.078"
	Minimum penetration at any spot	.062"
<u>Method (d):</u>	Average penetration for eight tubes	.067"
	Minimum penetration at any spot	.046"
<u>Method (1):</u>	Average penetration for eight tubes	.109"
	Minimum penetration at any spot	.062"

6.1.4.1.6 Metallurgical Considerations for Welded Joint Construction

(Most of the material in this section was taken from the article listed as Reference 1 in Par. 6.1.4.1.6).

When welding tubes of the stabilized grades of stainless steel such as 309Scb or 347 to tube sheets of the same stainless steel grade or of different grades, the exact chemical compositions of the tubes, tube sheets and welding rods (when employed) must be known to predict the possibility of weld or base metal cracking. In cases where cracking is predicted, it may be in order to change the type of welded joint, to use filler metal where a simple fusion type joint was originally considered, or to employ a different grade of filler metal from that originally considered.

The Schaeffler constitution diagram for iron-chromium-nickel weld metal described in Par. 6.1.1.2, is useful in predicting welding difficulties when working with the Cb stabilized stain-

#### 6.1.4.1.6

less steel grades. This diagram establishes the relationship between the chemical composition and the microstructure of the as deposited weld metal.

The composition of stainless steel tubes of the 18-8 type is usually deliberately balanced by the mill making them fully austenitic to provide optimum properties for the mill processes required to produce the tube to the desired specification properties. It is also possible for the tube sheets of the Cb stabilized grades to be fully austenitic, since rolling characteristics are improved when such a structure is present.

When tube to tube sheet welds are made with coated electrodes, weld cracking difficulties are seldom encountered, since electrode manufacturers normally use core wire and coating compositions which result in about 5 to 10% delta ferrite in the deposited weld metal. With normal penetration of the component base metals by the weld, the combination of melted base metals and melted electrode will generally result in sufficient delta ferrite in the austenitic weld metal (at least 2%) to prevent cracking.

When tube to tube sheet welds are made by fusing the component base metals together by the inert-gas tungsten arc method, there is the likelihood that the resulting weld will be fully austenitic. This could result in cracking when the columbium stabilized grades are being joined. Since automatic welding methods, which involve fusion of the parts being joined, are frequently used, the problem of weld cracking is serious. By the use of the proper type of weld joint, cracking can be minimized or prevented even though one component member when melted gives a fully austenitic weld or a weld containing less than 2% ferrite, as indicated below:

- a. In the event that the tube sheet material when melted gives a weld with over 2% ferrite, while the tube material gives a fully austenitic weld, weld types which involve the melting of equal or greater amounts of tube sheet material should be used. See Fig. 1, Methods (c), (d), (e), (f) and (h). If the combination of the melted tube and tube sheet material, say by Method (d), gives a deposit with less than 2% ferrite, the use of added filler metal is advisable.
- b. In the case where the tube material is slightly ferritic (over 2%) when melted and the tube sheet material is fully austenitic than weld types which involve the melting of equal or greater amounts of tube material should be used. See Fig. 1, Methods (a), (b), (c), (e), and (f).

By the use of the Schaeffler diagram and the compositions of the tubes, tube sheet and welding electrode, the composition of the weld metal can be predicted. In most cases, the resulting weld metal composition will contain sufficient ferrite that cracking will not occur. Figures 2(a), 2(b), & 2(c) show how the Schaeffler diagram can be used to predict crack sensitivity in weld deposits.

#### 6.1.4.1.6 - 6.1.4.1.7

In some cases, the tube and tube sheet may both be so highly austenitic that it is not possible to obtain a filler wire of suitable composition to provide the delta ferrite needed in the weld. In these cases, it is common practice to overlay the tube sheet with weld metal having the necessary chromium and nickel equivalents to provide adequate delta ferrite for making the subsequent tube welds. Figure 1, Method (r) shows a method of welding tubes to high ferrite overlays.

#### 6.1.4.1.7 Bibliography

The reader is referred to the following articles if he desires more information on the subject:

1. "The Welding of Some Nonferrous and Ferrous Tubes to Tube Sheets", R. W. Bennett, Welding Journal, Nov. 1958, pp. 1071-1080.
2. "Heat-Exchanger Fabrication", P. Patriarca, G. M. Slaughter and W. D. Manley, Welding Journal, Dec. 1957, pp. 1172-1178.
3. "Joining Tubes to Tube Sheets for Corrosive Radioactive Chemical Service", W. R. Smith, Welding Journal, Apr. 1956, pp. 307-310.
4. "Trepan Joint and Low Ferrite Overlay Stop Microfissuring", Industry and Welding, May, 1959, pp. 32-34.
5. "Commission XI: Recommended Welded Connections for Pressure Vessels", British Welding Journal, Apr., 1957, p. 179 (one page of tube to tube sheet details)
6. "G-R Automatic Welding Techniques", The Griscom-Russell Co., Bulletin AW-1.

FIG. 1 - TUBE TO TUBESHEET WELD DETAILS

SEAL WELDS

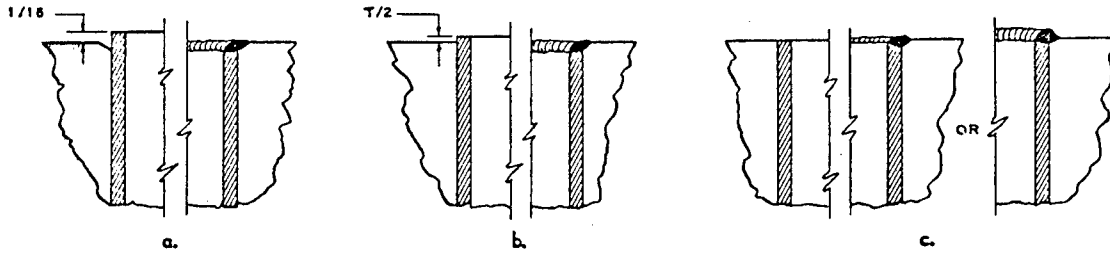

LOW RESTRAINT SEAL WELD

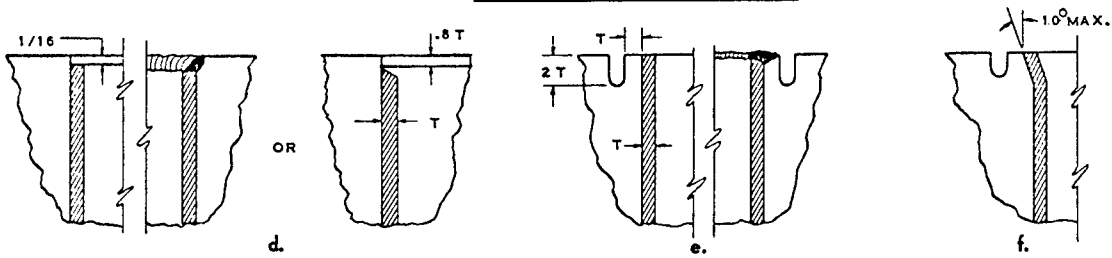

STRENGTH WELDS

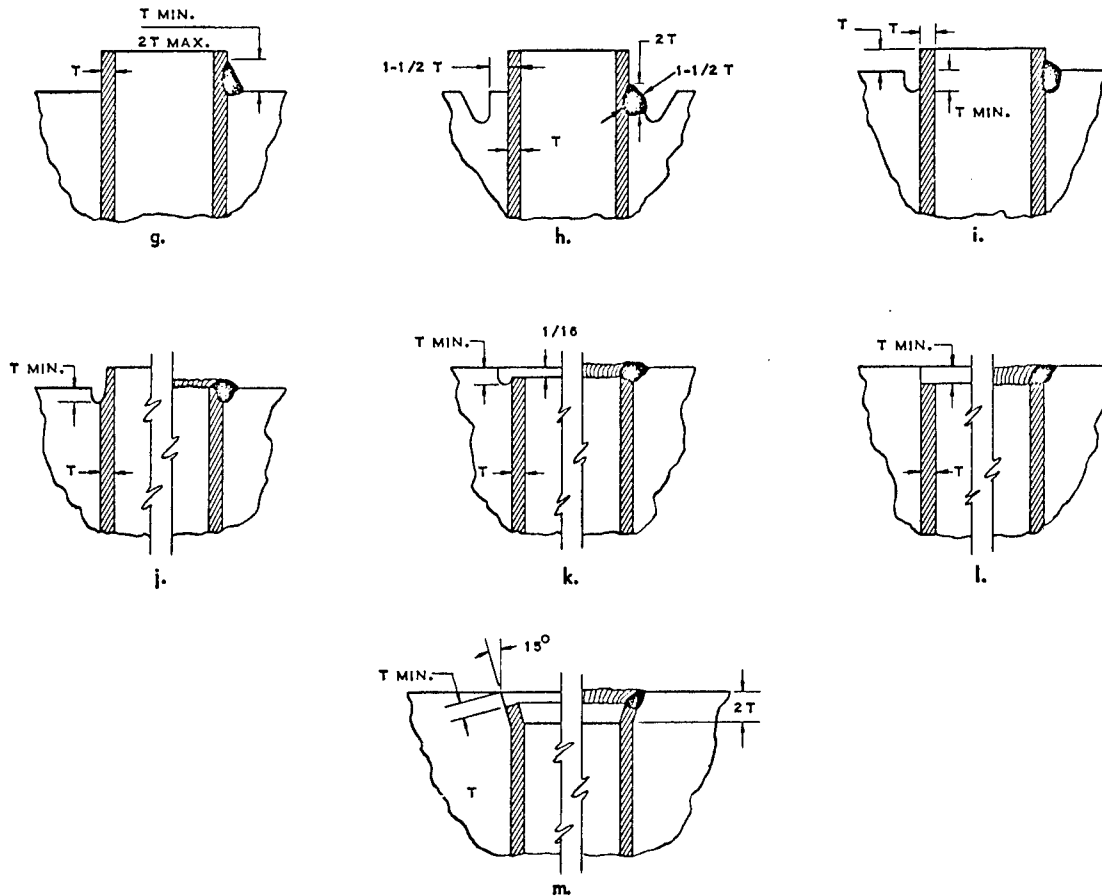

Par. 6.1.4.1 Fig. 1 Cont.

WELDS FOR SPECIAL APPLICATIONS

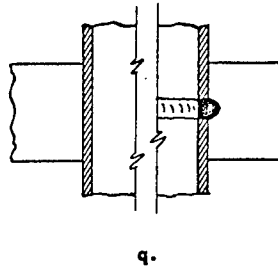
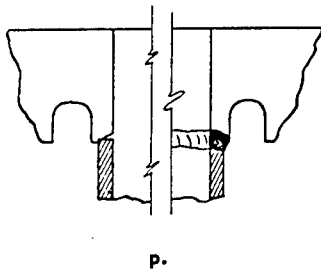
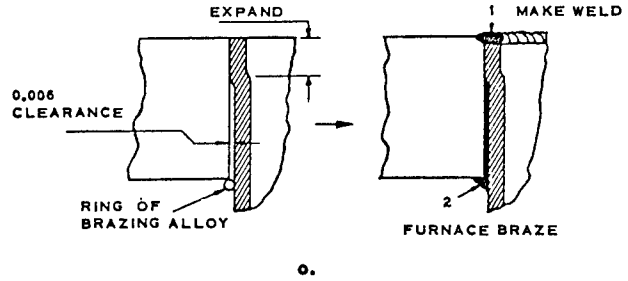
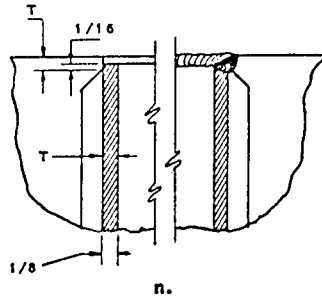

OVERLAY OF CONTROLLED FERRITE CONTENT

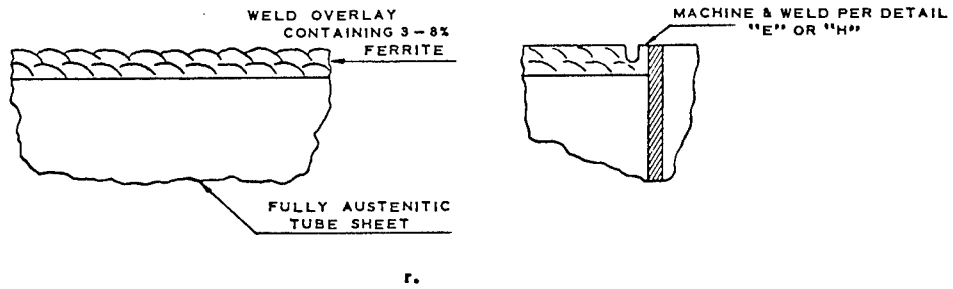

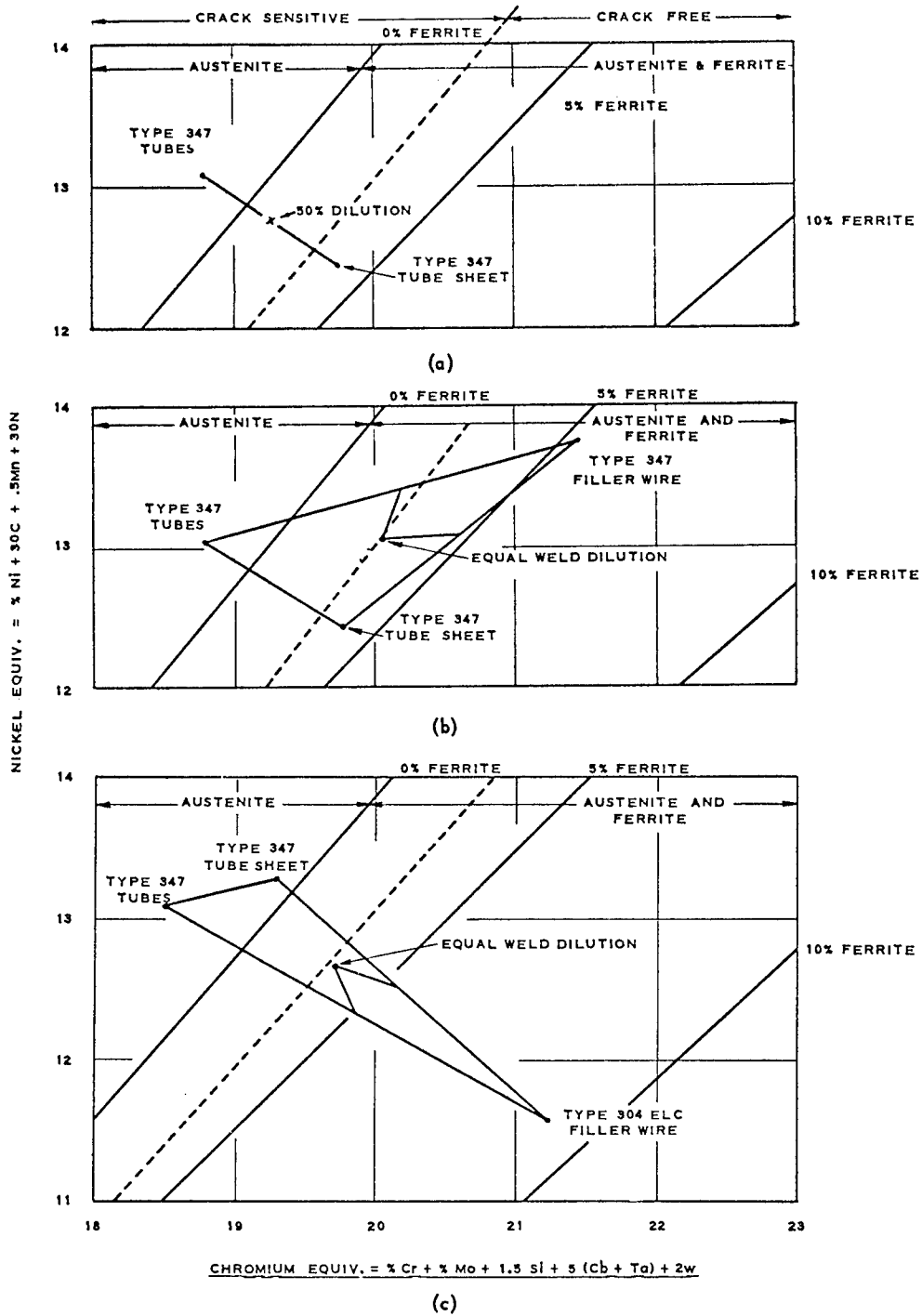

FIG. 2 - APPLICATION OF IRON-CHROMIUM-NICKEL CONSTITUTION DIAGRAM TO FABRICATION PRACTICE

6.1.4.2 - 6.1.4.2b

#### 6.1.4.2 Butt Welds in Pipe

##### a. General<sup>1</sup>

Since it is essential that a sound root pass be made to obtain maximum joint integrity, this section will be concerned primarily with the root pass of the weld and joint preparations which enable a welder to make a sound root pass.

The procedures generally used for the deposition of welds of high quality in austenitic stainless steel pipe require the use of the inert gas shielded tungsten arc method. Commercially available inert gas tungsten electrode holders are used with the normally recommended conditions for direct current, straight polarity and gas nozzle flow. In general, 1/16 in. or 3/32 in. diameter thoriated tungsten electrodes are used. The arc end of the electrode is ground to a pencil point which increases arc stability and ease of manipulation. When welding stainless steel pipe, all air must be purged from the pipe at the inside of the welded joint. In some cases, the whole length of pipe containing the joint is purged; in other cases, dams or fixtures are placed at a distance on either side of the joint to form a chamber which can be purged. In general, the internal purging is controlled by maintaining a positive pressure or a continuous gas flow in the purged volume. Prior to welding, the gas in the volume to be purged is displaced by maintaining a flow of inert gas for a given period of time.

Arc starts and stops should not be made in the weld puddle of the root pass. In order to avoid this, the usual practices are to use starting and stopping tabs or to run the arc off on the adjacent base metal within the groove, while extending the arc length very rapidly. It is usually recommended that the arc crater be filled in before the arc is removed from the root pass.

Argon and helium are most commonly used for the shielding and purging gas. Argon is generally preferred. Nitrogen has had limited usage as the backing or purging gas. Most procedures require that the purging gas be maintained for an additional one or two passes after the root pass has been deposited.

##### b. Butt Joint Details

Figure 1 gives the general nomenclature associated with the details of butt joint preparations.

Figure 2 illustrates various styles of butt joints and dimensional ranges used for inert-gas-shielded-tungsten-arc welding of pipe. The square butt joint, Style 1,

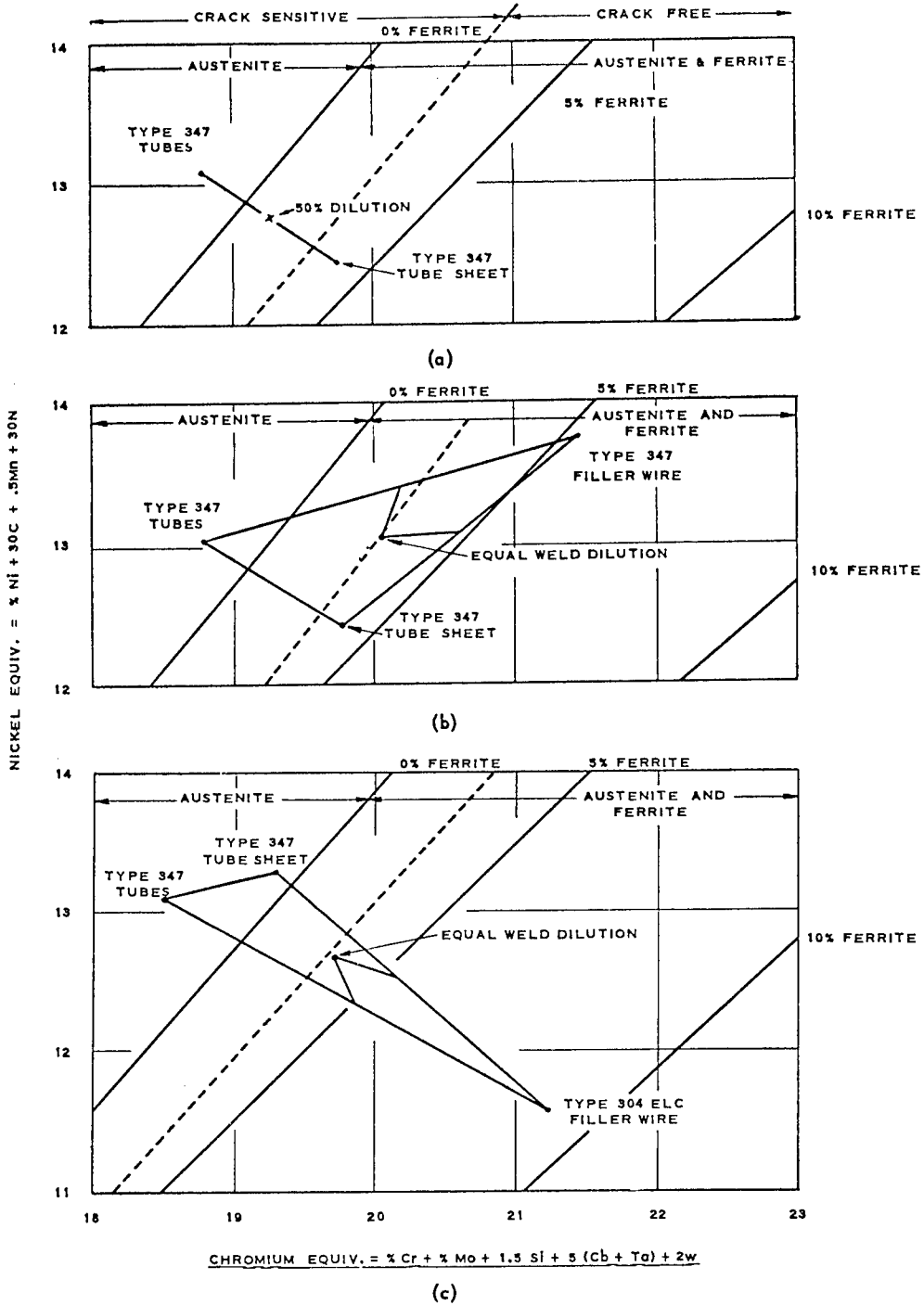

FIG. 2 - APPLICATION OF IRON-CHROMIUM-NICKEL CONSTITUTION DIAGRAM TO FABRICATION PRACTICE

is generally used for light gage pipe up to 1/8 in. wall thickness. Vee-groove joints, Style 2, having a nominal 75° included angle have been used successfully for selected materials up to 3/4 in. thick, where the welding conditions were optimum. This would include fabricating shops where the work can be positioned and rotated and where there is no restraint except the actual pipe mass<sup>1</sup>. (This method has been used almost exclusively for both shop and field welding at Savannah River Plant. The root opening was generally a little less than the diameter of the filler wire, or 1/16 in. - 1/8 in. in most cases. Filler metal was added to make the root pass when the pipe was in the horizontal or vertical fixed positions, but the root pass was made by fusing the joint together without addition of filler metal when the pipe was rotated in the horizontal position. Since Types 304 and 304L stainless steels were used for most piping applications, no weldability problems were experienced.)

Style 3 illustrates a modification of the Vee-groove, flat-land butt joint. (The term "flat-land" is used to describe the extension of the root face or "land".) A pipe wall thickness of 1/2 in. is often considered a desirable breaking point for changing to a U-type groove joint, Style 4. As the wall thickness of the pipe increases, a compound bevel is used after reaching 3/4 to 1 3/8 in. wall thickness to reduce the volume of weld metal required to complete the weld. Modified U-type joints having extended lands are used where root cracking is caused by high residual stress or low hot-weld strength, Styles 5 and 6<sup>2</sup>.

Two special butt joint preparations are illustrated in Figure 3<sup>1</sup>. The joint design shown as Figure 3 (a) is also known as the "GE" joint. The contour of this joint prior to welding is such that an essentially flat root contour is obtained by simply fusing the edges together. This is an expensive joint to prepare but is of value where very close control of root contour is necessary.

The joint illustrated by Figure 3 (b) is formed by rolling down the machined lip. Addition of filler metal is recommended with this joint<sup>2</sup>.

Figure 4 illustrates several consumable insert joint types<sup>1</sup>. The consumable insert permits control of root bead contour and weld composition.

c. Material Composition<sup>2</sup>

On many compositions of base metals, cracking or porosity often occurs during fusion of the root pass because of undesirable inherent metallurgical phases or anomalies resulting from segregations and other residual constituents such as phosphorus or sulfur being melted into the weld puddle. The addition of high-quality filler metal, having a more uniform and more closely controlled chemistry, to the weld puddle tends to improve the uniformity and quality of the root pass weld as well as to increase the cross sectional area at the root of the joint. The filler metal may be added manually during the actual tungsten-arc welding of the root pass or it may be added as a prefit insert ring.

Where austenitic stainless steel piping such as Types 304, 316 and especially 347 is used, a filler metal of carefully controlled chemistry is almost mandatory to provide a weld nugget free from cracks. Schaeffler (Schaeffler, A. L., "Welding Dissimilar Metals with Stainless Electrodes", Iron Age, July 1, 1948) has provided a constitution diagram (see Par. 6.1.1.2, Figure 1) showing the general relationship between the chemical compositions and the microstructure of the as-deposited weld metal. The axes of the diagram are based on the chromium and nickel equivalents rather than upon the elements only. The chromium equivalent consists of the total percentage compositions of the chromium, silicon, molybdenum, columbium, tantalum, and other ferrite formers. The nickel equivalent is based on the total of the nickel, manganese, carbon and other austenite formers.

Type 347 pipe generally exhibits a fully austenitic microstructure, while Types 304 and 316 may or may not be fully austenitic. When fully austenitic, if these types are fused together, cracking will generally occur. A controlled-composition filler metal that will deposit an undiluted weld having 5 to 10% delta ferrite in the austenitic matrix has been commonly used to overcome the cracking tendency. A resulting root pass weld having at least 3% delta ferrite in the austenite has been found necessary to obtain crack free welds.

Various filler wires with suitable chemistry to produce weld metal having essentially the same nominal composition and properties to match the base metal are available from many commercial suppliers. Insert rings are commercially in coils or standard ring sizes.

Another type of consumable weld insert is essentially a semicircular wire  $5/32$  in. in diameter with a projection  $0.063$  in. square for fitting between the pipe ends. It is also the practice for some companies to make their own inserts to various rectangular or trapezoidal cross sectional designs to accommodate specific conditions.

#### Sources of Information

1. "Welding Ferrous Materials for Nuclear Power Piping", Committee Report AWS D 10.5-59, American Welding Society, 1959.
2. "Tungsten-Arc Welding the Root Pass of Power-Pipe Joints", R. W. Bennett, Welding Journal, December, 1959.

Par. 6.1.4.2 Fig. 1

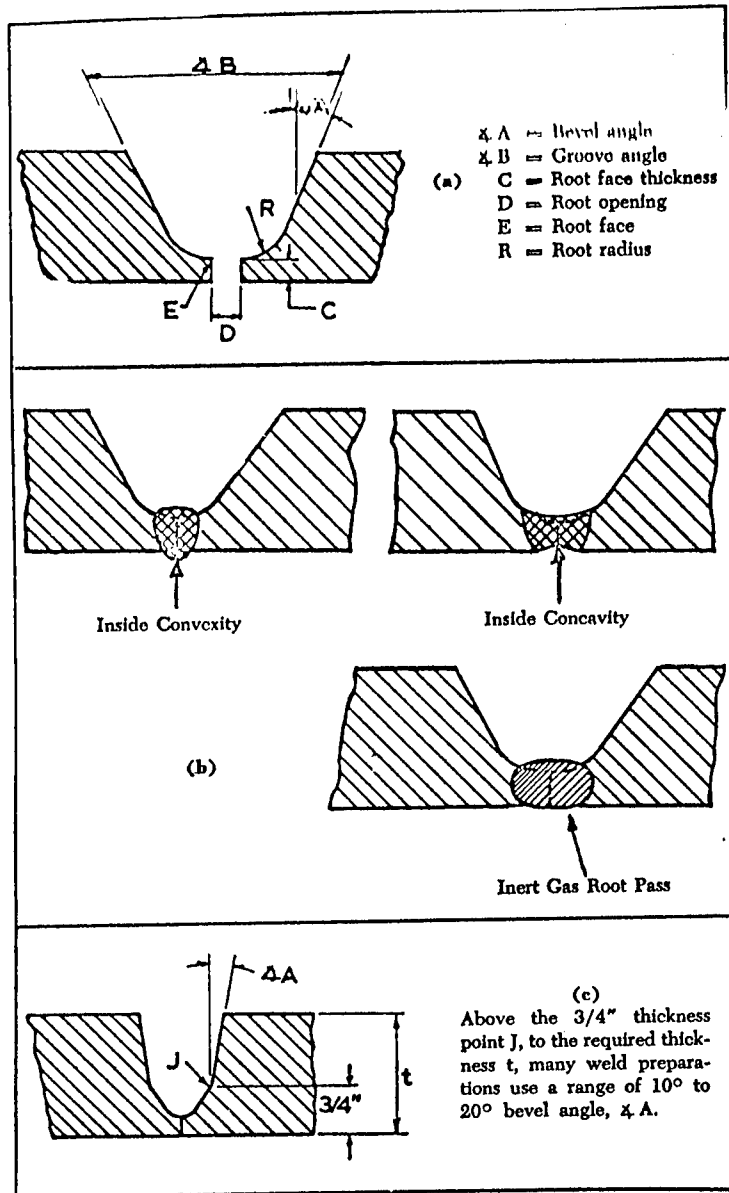

Fig. 1 - Butt Joint - General Nomenclature

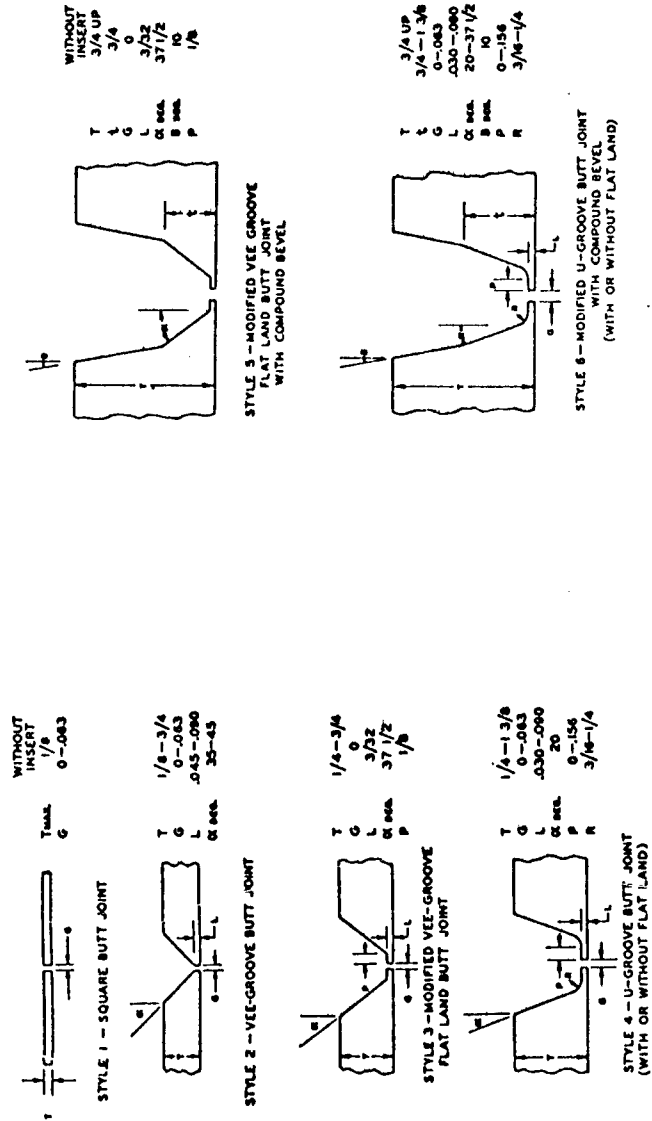
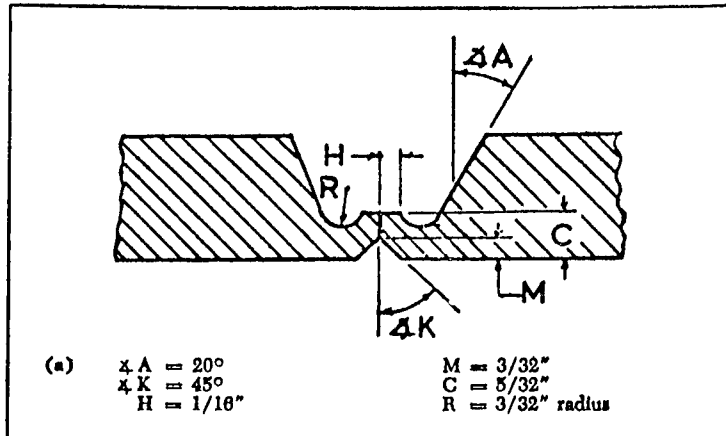
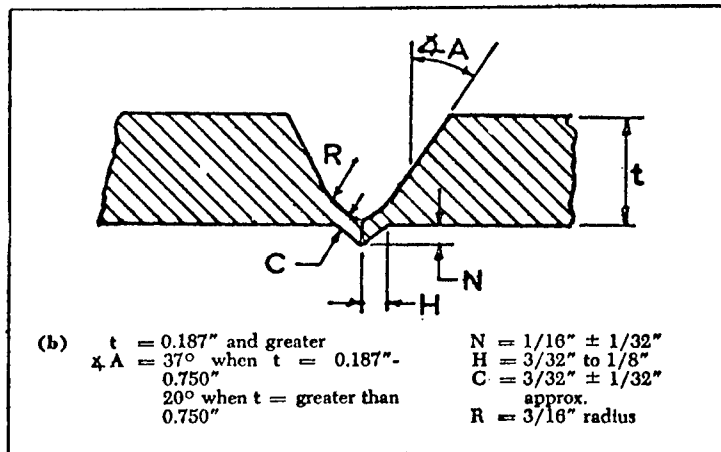

Figure 2 - Various styles of butt joints and dimensional ranges used for inert-gas-shielded tungsten-arc welding of pipe.

Par. 6.1.4.2 Fig. 3



a. "GE" Joint



b. Rolled Lip Joint

Figure 3 - Butt Joint - Special root face types

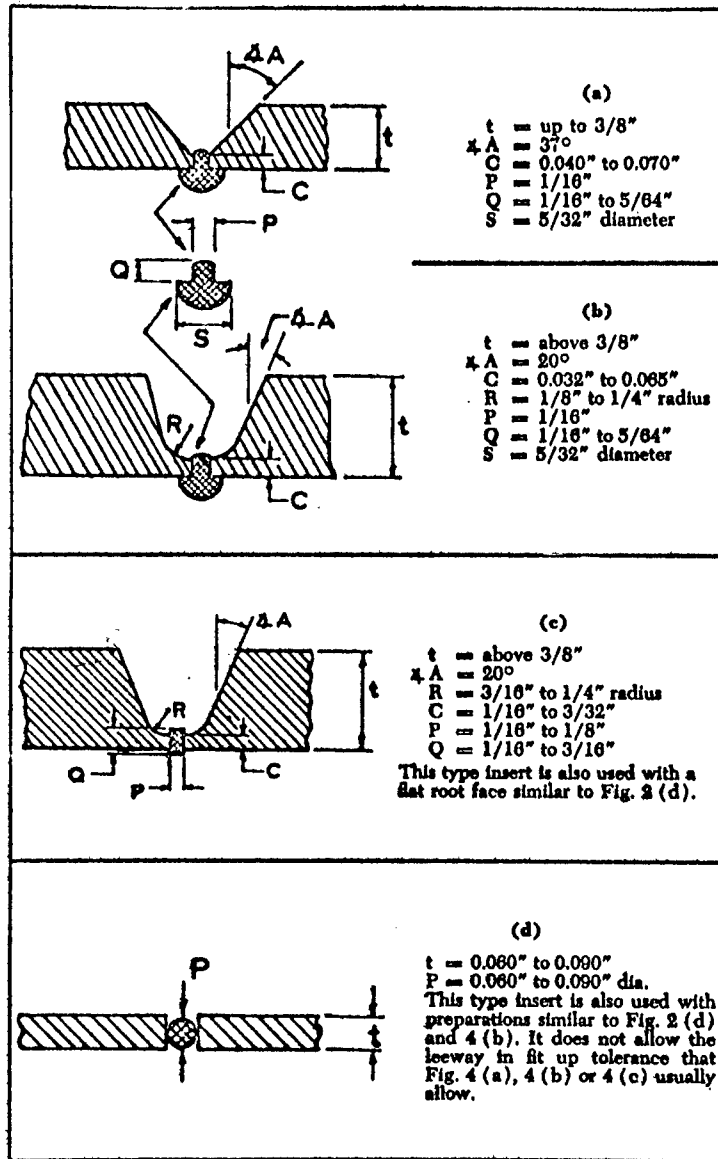

Fig. 4 - Butt Joint - Consumable Insert Type

### 6.1.4.3 - 6.1.4.3a

#### 6.1.4.3 Welding of Stainless Clad Steel Plate

##### a. General

This section will cover the joining of integrally clad plates in which the cladding is one of the austenitic stainless steels and carbon steel or low alloy steel is the backing material. (See Par. 6.1.4.3e for a description of manufacturing methods for clad plate.) Depending on the thickness of the clad plate and the ultimate usage of the equipment item fabricated from the plate, the welds may be made in one of the two methods listed below:

1. The carbon steel or low alloy steel backing material is joined with carbon steel or low alloy steel weld metal and the region where the stainless steel cladding was removed during joint preparation is overlaid with stainless steel weld metal.
2. The entire thickness of the clad plate is joined with stainless steel filler metal.

Where the backing steel is thick, as in the case of vessels for high pressure service, it is more economical to use method (1) above. In the case of relatively small clad plate thicknesses, method (2) above might be the easier way to make the joint at little or no increase in cost. In the case of elevated temperature operation or cyclic temperature operation, the possibility of difficulties arising from the difference in coefficients of expansion of the base plate and the weld should be considered. Butt welds of clad material may have the carbon steel backing welded with stainless steel, providing the service conditions do not involve a cycling operation with a difference of 450°F between the maximum and minimum operating temperature. The use of such a welding procedure shall also be limited to a maximum temperature of 450°F.

### b. Precautions

One of the principal sources of difficulties in the deposition of welds in clad plate construction is the joining of dissimilar metals at the carbon steel - stainless steel interface. Carbon steel weld metal should never be deposited directly on stainless steel by conventional procedures since dilution of the carbon steel weld metal by the stainless steel will result in sufficient alloying to produce a brittle deposit. (Par. 6.1.4.3d gives a special case where a technique was developed to deposit carbon steel over stainless steel using an intermediate layer of Armco iron and a very carefully controlled procedure.)

All stainless steel deposits on carbon steel should be made with filler metal of sufficiently high alloy content that normal amounts of dilution by carbon steel will not reduce the alloy content to such an extent that a brittle composition will result. In general, Types 308, 316 or 347 weld metal should not be deposited directly on carbon or low alloy steels. Types 309, 310, or 312 are widely used for stainless steel filler metal to be deposited on carbon or low alloy steels. Type 310 is a fully austenitic material subject to hot cracking when there is high restraint in a welded joint. When Type 310 is used the welds should be carefully inspected. Welds of Types 309 and 312 being partially ferritic are highly resistant to such cracking. Paragraph 6.1.6, "Overlay Techniques", and Paragraph 6.1.5 "Welding to Dissimilar Metals", discuss the problems which can occur when welding carbon steel to stainless steel.

When stainless steel weld metal is deposited over carbon steel at joints in the clad plate, sufficient thickness of weld must be employed to prevent migration of carbon in harmful amounts from the base metal to the surface of the stainless steel weld that will be in contact with the corrodent. Since different welding methods result in different amounts of weld bead penetration into the base metal with different amounts of dilution, tests should be conducted to determine the most suitable welding procedure if the equipment item will be exposed to strong corrodents.

#### 6.1.4.3b - 6.1.4.3c

Where the equipment item is of sufficient thickness to require stress relief after welding, the stainless steel cladding composition shall be an extra low carbon or stabilized grade if the corrodent to which it will be exposed is capable of causing intergranular attack on sensitized stainless steels of non-stabilized regular carbon grades.

#### c. Techniques

##### Method A

Figure 1, Method A, illustrates the most commonly used method for making welded joints in stainless steel clad carbon or low alloy steel plate where for economy or stress reasons it is desirable to deposit stainless steel weld metal only in that portion of the weld where the stainless steel cladding was removed in fabrication and to use carbon or low alloy steel weld metal for the remainder. The plate edges are beveled for welding as indicated in Step 1, the bevel ending 1/16 in. minimum above the stainless cladding. The carbon or low alloy steel weld is then deposited as shown in Step 2, care being taken not to penetrate any closer than 1/16 in. to the cladding. It is good practice to use a low hydrogen type electrode for the first carbon steel or low alloy steel layer to minimize the danger of cracking in the event that there is accidental penetration to the vicinity of the cladding.

The joint is next back gouged from the stainless steel side, as indicated in Step 3, removing the minimum amount of material necessary to reach sound carbon steel weld metal. In Step 4 the groove resulting from the back gouging operation is filled with stainless steel weld metal in a minimum of two layers, with an additional layer recommended if projection of the weld above the cladding surface can be tolerated. The first layer of stainless steel weld metal should be sufficiently high in alloy content to minimize difficulties from weld metal dilution by the carbon steel base metal. Penetration into the carbon steel should be held to a minimum. If the cladding is Type 304 stainless steel, the first layer of weld metal should be Type 309. (Type 310 would also be acceptable provided that each layer of weld metal is carefully inspected for cracks.) Subsequent layers should be Type 308.

Where the cladding material is Type 316 stainless steel, deposition of the first layer with Type 309 Mo will make it easier to achieve the proper composition in subsequent layers which should be deposited with Type 316.

Where the cladding material is Type 304L or Type 347, very careful control of welding procedure must be exercised to obtain the required weld metal chemistry in the outer layers of weld metal. The procedure should be confirmed by chemical analysis of sample welds prior to use in a vessel for severely corrosive conditions.

Some plants require that a strap of wrought material having the same composition as the cladding be welded over the completed weld, as shown in Step 5. This assures that there are no areas of lower corrosion resistance in the lining. The fillet welds joining the strap to the cladding should be carefully inspected after deposition.

#### Method B

Figure 2, Method B, illustrates an alternate method for the welding of clad plate in which a carbon steel or low alloy steel weld joins the base metal portion of the plate and limits the use of stainless steel to replacing the cladding where it has been removed prior to making the carbon or low alloy steel weld. This method would be more expensive than Method A in that an additional operation is required to strip back the cladding and to replace the stripped back cladding with stainless steel weld metal. This method allows the use of welding methods such as submerged arc in the deposition of the carbon steel weld since there is no danger of alloy contamination from the cladding layer.

Great care must be taken in depositing the stainless steel weld to replace the cladding removed adjacent to the weld. The first layer of stainless steel weld metal should be sufficiently high in alloy content that

#### 6.1.4.3c

cracking problems will not result from normal dilution by the carbon steel base metal. A stringer bead technique should be employed with care being taken to hold penetration to a minimum. Refer to Method A for information on welding filler metal composition. Since the stainless steel weld metal layer is rather thin, the proper weld metal chemistry might not be achieved after the second layer has been deposited. It might be necessary to grind off a portion of the second layer and deposit additional weld metal to assure that the desired composition has been achieved.

Alternate Step 3 involves the use of an inlay of wrought stainless steel rather than deposited weld metal to cover the exposed carbon steel. The edges of the strip of stainless steel are welded to the edges of the cladding.

#### Method C

Figure 3, Method C is essentially the same as Figure 2, Method B, except that the carbon steel or low alloy steel weld is deposited from the stainless steel side of the clad plate. Refer to Method B above for details.

#### Method D

Figure 3, Method D, illustrates the most common method of joining stainless steel clad carbon steel or low alloy steel plate with a weld that consists entirely of stainless steel. This method is most frequently used when rather thin clad plate is being fabricated.

After the plate has been beveled and fitted up for welding as shown, a stainless steel weld is deposited from the carbon steel side. The welding filler metal should be sufficiently high in alloy content to minimize the difficulties such as cracking which could result from dilution of the stainless steel weld by carbon steel. Type 309 would be suitable for this application and Type 310 could be used if the weld is carefully inspected for cracks. The stainless steel welding procedure should result in minimum weld metal dilution by the carbon steel. Since the stainless steel weld is under restraint, cracking may result if excessive dilution occurs.

After the stainless steel weld has been deposited from the stainless steel side as shown in Step 2, the root of the weld is cleaned by brushing, chipping, or grinding, as required, and one or more layers of stainless steel weld metal deposited as shown in Step 3. The weld metal composition should be that normally employed to weld the type of stainless steel used for the cladding. If the cladding is Type 304, the final layer of weld metal should be Type 308. If the cladding is Type 316, it might be necessary to back gouge prior to deposition of the final weld metal layers in Step 3 to assure that the proper weld metal chemistry is achieved at the surface of the weld.

#### Method E

Figure 4, Method E, is a variation of Method D, in that the entire weld is stainless steel, but that the weld is deposited from the stainless steel side of the clad plate. Welding details are similar to those set forth under Method D.

#### Method F

Figure 4, Method F, illustrates a method of making a full penetration corner joint which utilizes a solid stainless steel weld. After beveling and fitting up as shown in Step 1, the weld from the carbon steel side is deposited with a stainless steel electrode such as Type 309 which is sufficiently high in alloy content to minimize problems which can result from dilution of the stainless steel weld metal by carbon steel. Type 310 could also be used if the weld is carefully checked for cracks. In Step 3 the first layer should be deposited with Type 309 or 310, penetrating deeply enough to reach the previously deposited stainless steel weld. One or more layers are deposited over the first layer, using the filler metal composition normally employed for welding the type of stainless steel used for the cladding. Care should be taken in depositing the stainless steel weld in the carbon steel portion of the joint since dilution by carbon steel could cause cracking in this restrained weld. A stringer bead technique should be employed.

#### 6.1.4.3c - 6.1.4.3d

##### Method G

Figure 5, Method G, illustrates a method of depositing a full penetration corner weld in which the carbon steel portion of the clad plate is welded with carbon steel. This weld method would be less likely to give cracking problems than Method F. It involves more labor cost in the stripping back of the cladding.

After stripping back the cladding, beveling, and fitting up as shown in Step 1, the carbon steel weld is deposited in Step 2. At least the first layer of carbon steel weld should be deposited with low hydrogen type electrodes to minimize possibility of cracking in the event that the weld accidentally penetrates to the stainless steel cladding. In Step 3, the joint is back gouged from the stainless steel side until sound carbon steel weld metal has been reached.

The first layer or first two layers of stainless steel weld metal, depending on depth of the gouge in the carbon steel are deposited with an electrode sufficiently high in alloy content to minimize cracking problems resulting from carbon steel dilution. Type 309 is preferred, but Type 310 could be used with suitable precautions. The one or more additional layers should be deposited with the filler metal composition that is normally employed to weld the stainless steel type used for the cladding.

##### d. Special Procedures

On rare occasions a structure, vessel, or piping assembly is designed so that the cladding is on the inside, the inside of the vessel inaccessible for welding, and the service conditions are such that it is desirable to join the carbon steel portions of the item with carbon steel weld metal. Such was the case with the homogeneous reactor pressure vessel for Oak Ridge National Laboratories. It was necessary in this case to deposit carbon steel weld metal on the stainless steel weld. After much investigation of welding procedures (see Reference 2) the procedure described on the next page was adopted.

1. As shown in Figure 5, Method H, Type 347 weld metal was deposited in the 347 cladding from the carbon steel side of the joint to within 1/16 in. of the interface between the stainless steel and the carbon steel. (The cladding was 1/2 in. thick.) The root pass was made by fusing an insert ring by means of the inert gas shielded tungsten arc method.
2. Two layers of Type 308L weld metal were deposited over the Type 347 weld metal.
3. Two layers of Armco iron weld were deposited over the Type 308L weld metal, using small stringer beads and low amperage.
4. The weld was completed with E-7016 low hydrogen type electrodes.

If an application arises where it is essential that carbon steel be deposited over stainless steel, a special welding procedure should be developed with the assistance of metallurgists and welding engineers suitably experienced.

e. Manufacturing Methods for Stainless Clad Steel Plate

Three methods of manufacture of integrally clad plates are listed below:

1. Roll bonding, which uses pressure from a plate rolling mill, with the material at the proper temperature, to produce a bond between the two metals while reducing the composite assembly to the desired gage.
2. Vacuum brazing, which employs a vacuum between the cladding and backing material to obtain the effect of externally applied pressure to force the bonding surfaces together. This operation is performed at a predetermined temperature with a brazing alloy to assist in creating the bond. This method does not change the thickness of the cladding or backing material.

6.1.4.3e

3. Weld overlay uses one of several welding techniques to produce a weld metal deposit of uniform chemistry and physical characteristics over the desired area of the backing steel. Overlay techniques are discussed in Par. 6.1.7.

Other methods of manufacturing clad plate involve the use of resistance spot welding to attach stainless steel sheet to the backing plate, or the use of fusion welding to attach stainless steel strips to the backing plate.

The following A.S.T.M. specifications cover stainless steel integrally clad plate:

A.S.T.M. A-263 - Corrosion-Resisting Chromium Steel Clad Plate, Sheet, and Strip

A.S.T.M. A-264 - Corrosion-Resisting Chromium-Nickel Steel Clad Plate, Sheet, and Strip

Sources of Information:

Funk, W. H., "Interpretive Report on Welding of Nickel Clad and Stainless Clad Steel Plate", Welding Research Council Bulletin Series, Number 61, June, 1960.

Bledsoe, L. F., Daly, F. V., Elder, G. E., Gall, W. R., and Miller, E. C., "Fabrication of the Homogeneous Reactor Test Vessel Assembly", Welding Journal, October, 1956.

METHOD A

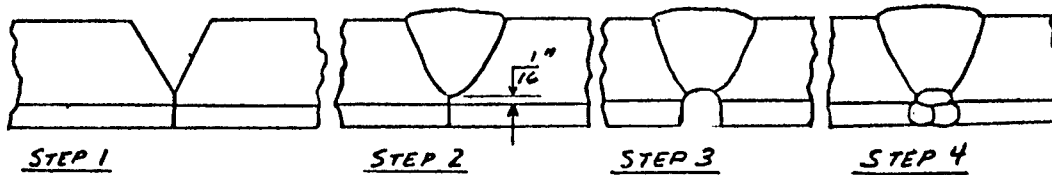

Step 1 - Tight fit up is desirable. Point of groove should be  $\frac{1}{16}$  in. min. above the stainless steel cladding.

Step 2 - Deposit carbon steel weld from carbon steel side. First pass should be deposited with a low hydrogen type electrode to minimize possibility of cracking in the event that penetration accidentally reaches cladding. Penetration should not extend beyond  $\frac{1}{16}$  in. from cladding.

Step 3 - Gouge from stainless steel side until sound carbon steel weld metal has been reached. Do not gouge deeper than necessary.

Step 4 - Deposit stainless steel weld metal to fill groove resulting from gouging operation. (See Par. 6.1.4.3c for details.)

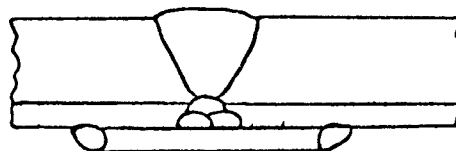

STEP 5

Step 5 - Some plants require for severely corrosive services that a strip of stainless steel of the same composition as the cladding be fillet welded to cladding to cover the weld.

METHOD B

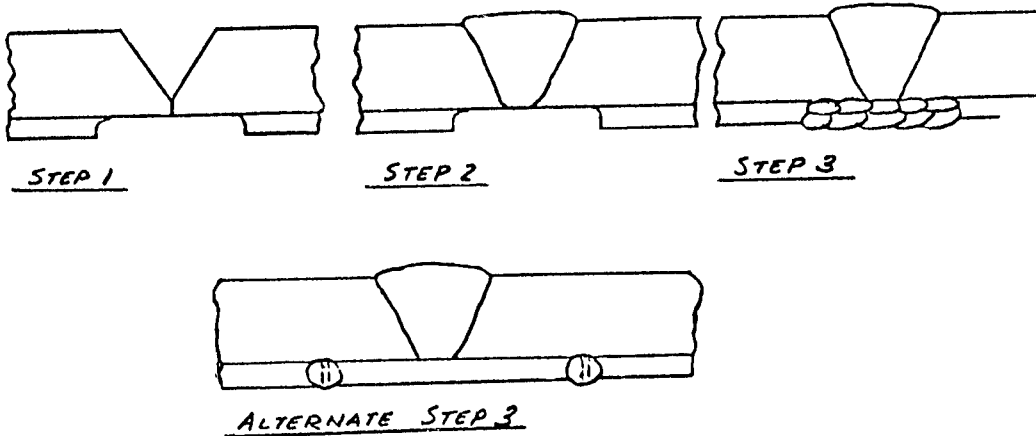

Step 1 - Strip cladding back  $\frac{3}{8}$  in. min. from each side of joint. Bevel and fit up. Tight joint as shown or root gap may be used.

Step 2 - Deposit carbon steel weld by any of the conventional methods and grind root flush with underside of carbon steel plate.

Step 3 - Overlay area where cladding has been removed with at least two layers of stainless steel weld metal. (See Par. 6.1.4.3c for details.)

Alternate Step 3 - Instead of overlay welding in the area where cladding has been removed, an inlay of a strip of wrought stainless steel can be welded in place.

METHOD C

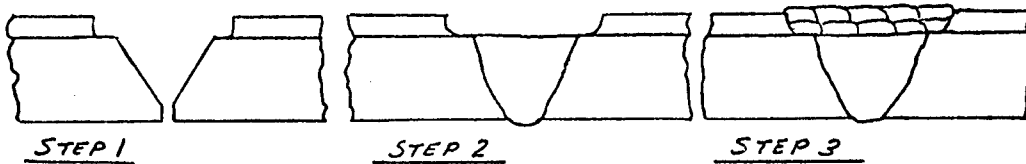

Step 1 - Strip back cladding, bevel, and fit up as shown.

Step 2 - Deposit carbon steel weld by any of the conventional methods. Do not deposit carbon steel on the stainless steel cladding.

Step 3 - Deposit at least two layers of stainless steel weld metal to restore the stainless steel layer in the area where the cladding has been removed. (See Par. 6.1.4.3c for details.)

METHOD D

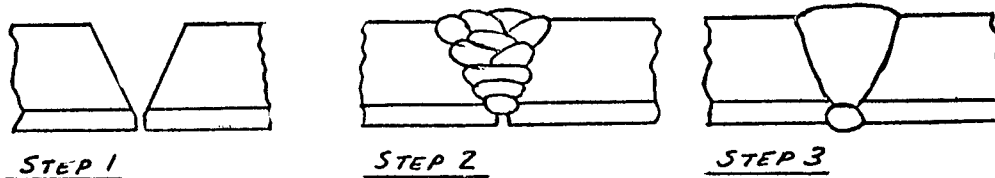

Step 1 - Bevel and fit up as shown.

Step 2 - Deposit stainless steel weld from carbon steel side. (See Par. 6.1.4.3c for details.)

Step 3 - Clean root of weld to remove slag or oxide. Gouge if necessary. Deposit weld with electrode type normally used to weld cladding composition. (See Par. 6.1.4.3c for details.)

Par. 6.1.4.3 Fig. 4

METHOD E

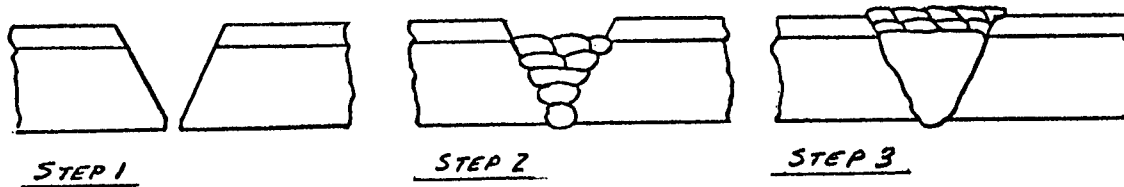

Step 1 - Bevel and fit up as shown.

Step 2 - Deposit stainless steel weld from stainless steel side. (See Par. 6.1.4.3c for details.)

Step 3 - Deposit stainless steel weld to replace area where cladding has been removed. (See Par. 6.1.4.3c for details.)

METHOD F

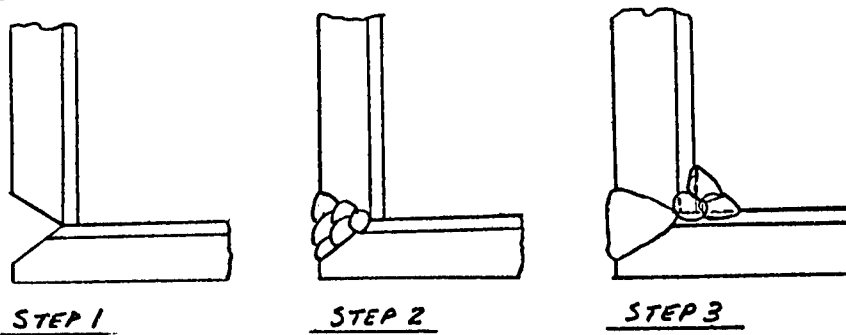

Step 1 - Bevel and fit up for welding.

Step 2 - Deposit stainless steel weld from carbon steel side. (See Par. 6.1.4.3c for details.)

Step 3 - Brush, grind, or back gouge as required and deposit remainder of weld from stainless steel side. (See Par. 6.1.4.3c for details.)

METHOD G

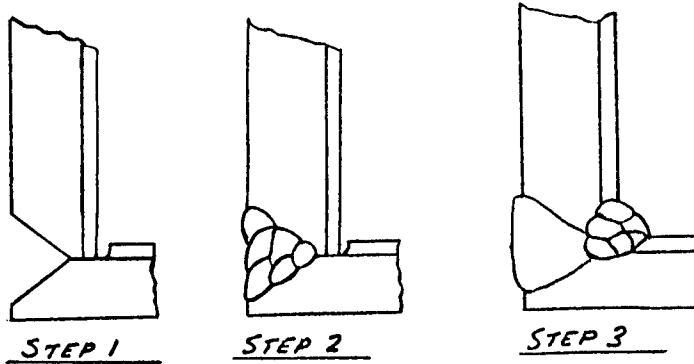

Step 1 - Strip back cladding, bevel, and fit up for welding.

Step 2 - Deposit carbon steel weld from carbon steel side. (See Par. 6.1.4.3c for details.)

Step 3 - Back gouge from stainless steel side and deposit stainless steel weld. (See Par. 6.1.4.3c for details.)

METHOD H

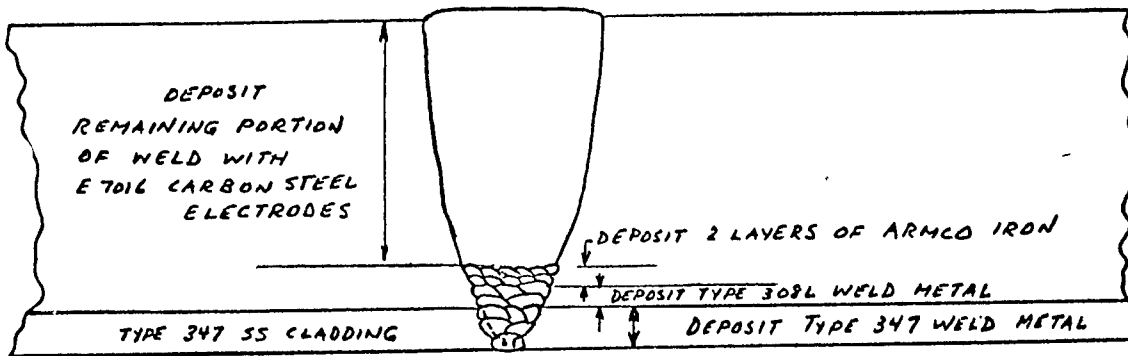

This is an example of a successful application where carbon steel weld metal was deposited over stainless steel. (See Par. 6.1.4.3d for details.)

6.1.5 to 6.1.5.2a

## 6.1.5 Welding to Dissimilar Metals

### 6.1.5.1 General

This section will cover the welding of the following dissimilar metal compositions:

- a. Austenitic stainless steels to carbon or low alloy steels.
- b. Ferritic and martensitic stainless steels to carbon or low alloy steels.
- c. Austenitic stainless steels to ferritic or martensitic stainless steels.
- d. One type of austenitic stainless steel to another austenitic stainless steel.
- e. Austenitic stainless steels to copper and copper alloys.
- f. Austenitic stainless steels to nickel and nickel alloys.

### 6.1.5.2 Austenitic Stainless Steels to Carbon or Low Alloy Steels

#### a. General

In the joining of austenitic stainless steels to carbon or low alloy steels for low and moderately high temperatures (say not over approximately 700°F.) it is customary to use a stainless steel welding rod that is sufficiently high in total alloy content to prevent martensite formation when diluted with carbon steel while at the same time preserving residual amounts of ferrite, which counteract the tendencies for hot cracking (at the time of welding) even under conditions of severe restraint.

Type 309 (25 Cr - 12 Ni) is probably used more than any other electrode for joining carbon steel to stainless steel (including overlay welding) for equipment, such as nuclear power reactor pressure vessels, which will be exposed to severe operating conditions. Type 312 (29 Cr - 9 Ni) also enjoys some usage in joining carbon steel to stainless. Type 309 would normally contain about 5 to 10% ferrite, while Type 312

would be strongly ferritic, over 20% ferrite. Although Type 310 is widely used for welding carbon steel to stainless steel, it is not employed by nuclear power reactor manufacturers because of its fully austenitic microstructure. The austenitic microstructure in Type 310 stainless steel weld metal is susceptible to hot cracking at the time of welding in highly restrained weld joints and also, if Type 308 weld metal is applied over Type 310 as in overlay welding on carbon steel, or when 304 is being welded to carbon steel, the normally partially ferritic Type 308 deposit when diluted with Type 310 may also become fully austenitic and crack sensitive. Much Type 310 has been used for welding stainless steel to carbon steel for other than critical services and in most cases the welds are satisfactory. The success is partially due to the dilution of the Type 310 deposit by carbon steel, making the deposit partially ferritic and less likely to crack.

The use of INCO-WELD A electrode or INCONEL Filler Metal 92, will also produce satisfactory welds when joining the austenitic stainless steels to carbon steel.

When making a transition joint between austenitic stainless steel and carbon steel, it is good practice to "butter" the carbon steel surface with a layer of Type 309 or other suitable stainless steel weld metal prior to actually joining it to the stainless steel. In this manner the portion of the joint where difficulties are most likely to occur is deposited while there is little restraint on the weld metal. Following the deposition and inspection of the "battered" layer or layers, the joint between the stainless steel member and the "battered" layer will be a conventional stainless steel to stainless steel joint. The welding rod in this case can be the type normally used to weld the stainless steel member of the joint (i.e., Type 308 if the stainless steel member is Type 304).

Paragraph 6.1.6 on overlay welding gives additional information on precautions to be taken when depositing stainless steel over carbon steel.

The deposition of carbon steel or low alloy steel weld metal on stainless steel results in hard, brittle

#### 6.1.5.2a - 6.1.5.2b

weld deposits which frequently crack when deposited and which would be likely to fail in service. Do not deposit carbon steel or low alloy steel weld metal on stainless steel.

#### b. Procedures for Stainless Steel to Carbon Steel Transition Joints

Figures 1 and 2 illustrate three methods of joining stainless steel components to carbon steel or stainless clad carbon steel. Method A (Figure 1) has been widely used in the welding of stainless steel pipe to stainless steel lined carbon steel or low alloy steel nozzles in nuclear power reactor pressure vessels. The overlay or "battered" layer that is applied to the carbon steel surface should be of sufficient thickness that the subsequent welding operation will not adversely affect the carbon steel base metal. If the right hand member of the joint shown under Method A is solid carbon steel, Type 309 should be used for the overlay operation. Great care must be taken in depositing the overlay to keep carbon steel dilution of the stainless steel weld metal to a minimum. Excessive dilution can cause cracking of the stainless steel weld metal. Stress relieving, when required, should be performed after deposition of the stainless steel overlay. The final weld between the solid stainless steel and the "battered" surface on the carbon steel can be made with the filler metal composition normally employed for welding the solid stainless steel member or the composition used to apply the overlay on the carbon steel member.

Method B (Figure 2) employs a short stainless steel member which is welded to the carbon steel or stainless clad carbon steel member prior to the stress relieving operation. This method insures that the final weld, Figure 2, Weld No. 2, will have no effect on the carbon steel base metal. Stress relieving is performed while there is little restraint on the joint. The final weld is a simple stainless to stainless joint. This method is more costly than Method A. In Methods A and B the most critical portion of the weld, those beads of stainless steel which contact the carbon steel, are deposited under conditions of very low restraint.

Method C is the least desirable of the three methods. In this method the stainless steel and the stainless clad carbon steel or carbon steel member are beveled and fit up for welding, leaving a suitable root gap. The two are then joined, using an electrode sufficiently high in alloy content that cracking of the stainless steel weld will not occur with normal dilution from the carbon steel. The welding procedure used should hold penetration into the carbon steel to a minimum. One disadvantage with this method is that the most critical portion of the weld is deposited while the weld is under restraint. Another is that local stress relief of the weld must also be performed on a restrained joint.

c. Transition Joints for Service at Elevated Temperatures

It is difficult to set forth firm rules for transition joints between austenitic stainless steels and carbon or low alloy steels for elevated temperatures. At the temperatures usually encountered in pressurized water type power reactors (around 600°F.) the use of a stainless steel weld to join solid stainless steel pipe to reactor pressure vessel nozzles which have been "battered" with stainless steel weld metal and stress relieved is common practice.

In conventional steam boiler applications where superheated steam temperatures may reach 1,400°F., the problems associated with transition joints between austenitic stainless steels and low alloy or carbon steels become more serious. Each transition joint application should be considered individually by metallurgists and welding engineers experienced in that field. The following information from the published literature on the subject is intended only to point out that this is a difficult subject and to indicate the approximate temperature where conventional transition welds are not adequate.

The article "Austenitic Welds in Type 502 Steel Piping", by H. G. Geerlings and W. P. Kerkhof, Welding Journal, March, 1957, stated that, in service in a refinery, 20 years of satisfactory results had been experienced with the use of 25 Cr - 20 Ni electrodes for joining 5% Cr - 1/2% Mo pipe. They had experienced some failures in the weld deposits, but not associated with the dissimilar

### 6.1.5.2c

metal feature. The authors concluded that austenitic stainless steel joints in 5% Cr - 1/2% Mo piping can be used up to about 950°F.

The article "Welds Between Dissimilar Alloys in Full-Size Steam Piping", by Blaser, Eberle, and Tucker, Proceedings of A.S.T.M., Volume 50, 1950, gives results of tests on welds in 10 3/4 in. dia. pipe between austenitic stainless steels and 2 1/4 Cr - 1 Mo low alloy steel at 1,100°F. and 1,500 p.s.i. internal pressure. After 4,631 hours at the above conditions along with 47 week end shutdowns to atmospheric conditions, cracks were detected. Welding was performed with Type 347 stainless steel electrodes.

Microscopic examination of various samples removed from cracked and crack-free sections of the two dissimilar weld joints confirmed that cracking was initiated in the 2 1/4 Cr - 1 Mo pipe surface close to and adjacent to the weld metal interface. During the high-temperature part of the temperature cycle, the 2 1/4 Cr - 1 Mo material scaled readily and formed an abrupt step-like change from the stainless steel weld metal surface to the 2 1/4 Cr - 1 Mo pipe surface. This abrupt change undoubtedly promoted stress concentration and concomitant accelerated localized oxidation of the low alloy material, leading to the development of an oxide notch at the highly stressed weld junction.

Under the combined influence of stress concentration and oxidation, the stress-raising oxide notch which formed in the 2 1/4 Cr - 1 Mo pipe surface adjacent to the weld metal junction developed into a crack which propagated inwardly in an intercrystalline manner, always following the fusion zone at a close distance. It is important to note that the cracks were located entirely in the 2 1/4 Cr - 1 Mo base metal. Carbon depletion of the low alloy base metal occurred. Carbon seems to have concentrated in the fusion zone and there is also evidence that some of the carbon had diffused into the Type 347 stainless steel weld metal.

The following statement on decarburization is taken from the article "Welding Stainless Steel to Carbon or Low Alloy Steel", by J. J. B. Rutherford, Welding Journal, January, 1959. Failures of the dissimilar welds tested to destruction have all involved accelerated-oxidation cracking adjoining the fusion zone. This occurs within the decarburized area where the oxidation must be accelerated, even if only slightly, by the absence of carbon. Tests performed by the author have established that decarburization in this type of service occurs mainly between 1,000 and 1,450°F., the transformation temperature. The driving force to decarburization lies in the difference in carbon solubility between ferrite and austenite probably more than the affinity of chromium for carbon.

#### 6.1.5.3 Ferritic and Martensitic Stainless Steels to Carbon or Low Alloy Steels

When welding ferritic or martensitic stainless steels to carbon or low alloy steels for general purposes (not high temperature service) austenitic stainless steel filler metal or modified INCONEL (INCO-WELD A) will produce welds of suitable quality provided that the correct welding procedures are followed. Paragraph 6.1.1.3 on the weldability of the straight chromium stainless steels sets forth the problems that can occur with these grades and recommends suitable heat treatments to minimize the problems.

There are two methods of making such a joint. The first would involve overlaying each member of the joint, utilizing suitable preheat and postheat treatments as required, and then making a weld without preheat or postheat between the overlaid surfaces. Austenitic stainless steel electrodes such as Type 309 which are sufficiently high in alloy content to minimize the problems from dilution by the carbon steel or straight chromium stainless steels are widely used for this application. INCO-WELD A is also suitable. The welding procedure used should hold penetration into the base metal to a minimum. The second method would involve depositing the weld, with either of the filler metal compositions listed above, directly between the two members of the joint. In this case, control of dilution of the weld metal by both of the base metals must be exercised while depositing the restrained weld.

### 6.1.5.3 - 6.1.5.5

This is less desirable than the first method where the joint between the weld and the base metal is made under conditions of low restraint. Preheat and postheat operations in this case are also more difficult.

#### 6.1.5.4 Austenitic Stainless Steels to Ferritic or Martensitic Stainless Steels

When welding austenitic stainless steels to straight chromium ferritic and martensitic stainless steels, good practice would require that the straight chromium member be preheated, if necessary, overlaid with a suitable austenitic stainless steel deposit, postheated if necessary, and then joined to the austenitic stainless steel member with an austenitic stainless steel weld. Paragraph 6.1.1.3 lists weldability problems which can occur with the straight chromium stainless steels and recommends preheat and postheat treatments. The use of an austenitic welding rod such as Type 309 and a welding procedure which holds dilution of the weld by the straight chromium member to a minimum is recommended. Type 309 is sufficiently high in alloy content to minimize the effects of dilution.

Austenitic stainless steels can be welded directly to straight chromium martensitic or ferritic grades with a Type 309 welding rod or electrode. The problem is more difficult since the weld in this case would be restrained and there is an increased possibility of cracking difficulties from weld metal dilution. Preheat and postheat treatments in this case must be applied to the entire joint.

#### 6.1.5.5 Welding One Type of Austenitic Stainless Steel to Another Austenitic Stainless Steel Type

Paragraph 6.1.3.3, Table 1, gives the recommended grades of filler metal for joining the various combinations of austenitic stainless steel types. In general, there is no reason to use the more highly alloyed or more corrosion resistant type when a filler metal composition matching the less highly alloyed or less corrosion resistant member offers no weldability problems. There is no reason to have the weld any stronger or more corrosion resistant than the weaker or less resistant of the two types.

6.1.5.6 Austenitic Stainless Steels to Copper and  
Copper Base Alloys

When welding austenitic stainless steels to copper and copper base alloys, the following method is recommended:

1. After beveling, preheat the copper or copper alloy part to about 1,000°F. and overlay the bevel area and well over the edges of the bevel with Nickel Welding Electrode 141 or Nickel Filler Metal 61. Sufficient overlay should be applied so that, after final joint preparation, the thickness of nickel is at least 5/32".
2. Restore the bevel angle by grinding or machining.
3. Position stainless steel beveled edge and provide a root gap of approximately 1/8 in. between it and the bevel of the nickel overlay on the copper.
4. Deposit weld with one of the alloys listed in Item 1 above.

6.1.5.7 Austenitic Stainless Steels to Nickel and  
Nickel Base Alloys

The following table lists the latest (March, 1964) recommendations of the Huntington Alloy Products Division of the International Nickel Company, Inc., regarding the welding of stainless steels to MONEL alloy 400, Nickel 200 or 201, and INCONEL alloy 600.

<u>Dissimilar Metals</u>	<u>Metal Arc Welding Electrodes</u>	<u>Inert Gas Arc Welding</u>
MONEL alloy 400 to stain- less steel	INCO-WELD A Electrode INCONEL Welding Electrode 182	INCONEL Filler Metal 82* INCONEL Filler Metal 92
Nickel 200 or 201 to stain- less steel	INCO-WELD A Electrode INCONEL Welding Electrode 182	INCONEL Filler Metal 82* INCONEL Filler Metal 92
INCONEL alloy 600 to stain- less	INCO-WELD A Electrode INCONEL Welding Electrode 182	INCONEL Filler Metal 82* INCONEL Filler Metal 92

\*First choice

#### 6.1.5.7

The following general information on welding of dissimilar metals to nickel and nickel base alloys has been furnished by the Huntington Alloy Products Division of the International Nickel Company, Inc.

"Joint design and electrode manipulation should be directed toward obtaining minimum dilution of the weld by the stainless steel. A moderate increase in the included angle of joints may be necessary to provide room for proper manipulation of the electrode in order to obtain minimum dilution. Crack sensitivity of the weld metal will be in proportion to the amount of dilution, particularly where the composition of plate and electrode differ by a considerable amount.

"Some general considerations are given below:

1. Since conditions encountered in fabrication welding may vary considerably with respect to stress, joint design and plate dilution, each application should be examined carefully with these variables in mind.
2. Certain weld compositions should be avoided:
  - a. A ferritic weld deposit if dilution by nickel, chromium, or copper is to be encountered.
  - b. The 18-8 (stainless steel) type of weld deposit if dilution by more than 3% copper is to be encountered.
  - c. A high carbon MONEL nickel-copper deposit if dilution by iron is to be encountered.

- d. Any MONEL nickel-copper deposit if dilution by more than 6 to 8% of chromium is anticipated.
- e. The 18-8 (stainless steel) type of deposit if dilution by nickel and chromium is sufficient to result in the crack-sensitive 35% Ni - 15% Cr weld composition".

Union Carbide Corporation, Stellite Division, in their bulletin "Fabrication of Hastelloy Alloys" makes the following recommendation for the welding of dissimilar alloys:

Whenever it is required to join the HASTELLOY alloys to another material such as other nickel-base alloys or stainless steels, and the assembly will be in contact with the corrosive environment, it is recommended that the welding electrode or rod be of the same composition as the more noble alloy, --- in most cases, the HASTELLOY alloys. Electrodes or filler rod are available to match all compositions of the HASTELLOY alloys used in corrosion service.

Nickel-base HASTELLOY alloy W was specially developed for welding dissimilar alloys for high temperature service. It has essentially the same composition as HASTELLOY alloy B with 5 per cent additional chromium content. It has been used very effectively for a number of years for joining different cobalt-base alloys and nickel-base alloys, and also stainless steels.

The term "HASTELLOY" is a registered trade mark of Union Carbide Corporation.

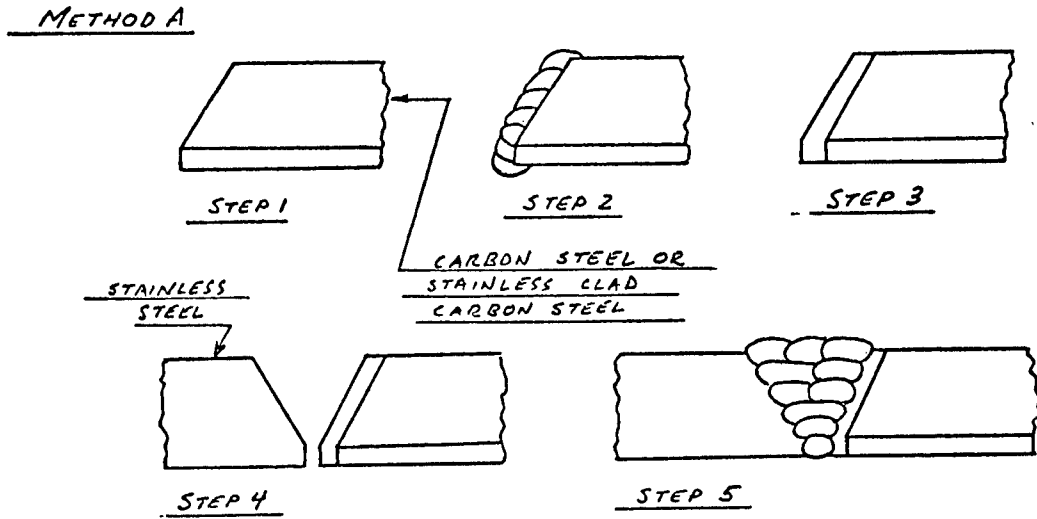

- Step 1 - Bevel edge of carbon steel or stainless clad carbon steel plate for welding.
- Step 2 - Apply overlay or "battered" layer of stainless steel weld metal of suitable alloy content to avoid problems from dilution by carbon steel. Use welding procedure that results in minimum penetration of weld metal into carbon steel.
- Step 3 - Machine or grind to restore required dimensions. Stress relieving, if required, may follow this step.
- Step 4 - Fit up for welding.
- Step 5 - Deposit stainless steel weld by any suitable process, using the filler metal which is normally employed for welding the stainless steel member, or the same filler metal that was employed to apply the overlay or "battered" layer on the carbon steel member.

METHOD B

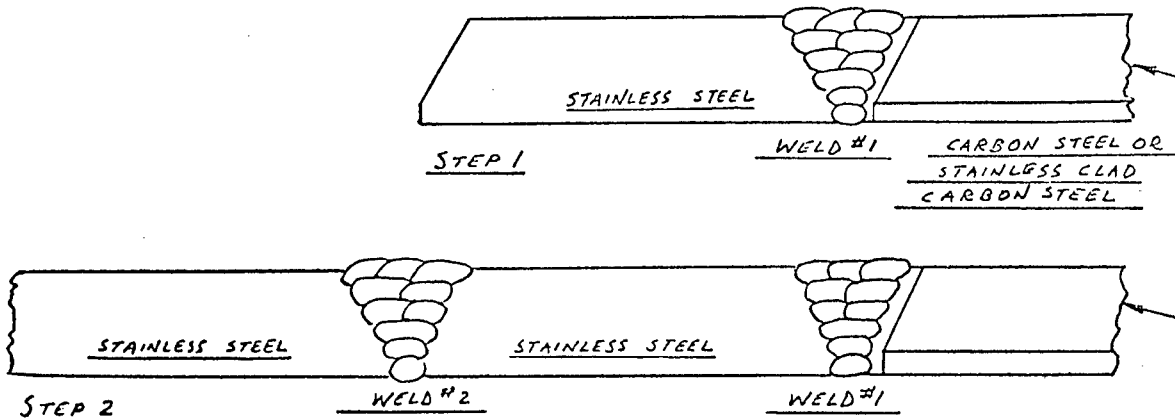

Step 1 - Deposit weld No. 1 by Method A (see Fig. 1).  
Stress relieve, if required.

Step 2 - Deposit stainless steel weld joining the two stainless steel members, by any suitable method. Use welding filler metal that is normally employed to weld the type of stainless steel involved.

METHOD C

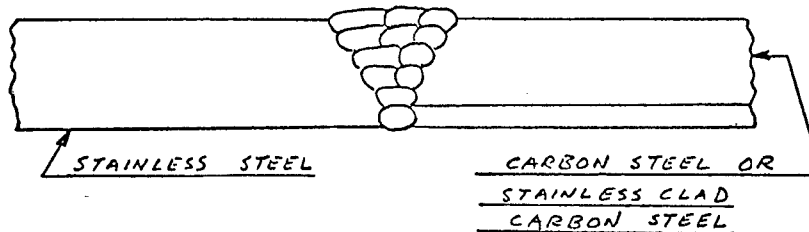

Bevel both members and fit up leaving a root gap. Deposit the weld using stainless steel filler metal of sufficiently high alloy content to avoid problems from carbon steel dilution. Welding procedure employed should hold penetration into the carbon steel to the minimum value possible.

## 6.1.6 - 6.1.6.2

### 6.1.6 Overlay Techniques

#### 6.1.6.1 General

With the advent of pressurized water reactors, the use of overlay welding has become necessary because of the heavy sections of plate and forgings involved, and the requirement that surfaces in contact with the water be stainless steel. Since the cost of solid stainless steel plate and forgings would be prohibitive, the use of clad carbon steel components has become widespread. Shells can be made from mill clad plate or from carbon steel plate that is clad by overlay welding after being formed into the shell. Forgings are almost always clad by overlay welding.

The welding rods and electrodes and procedures used in the cladding of carbon and low alloy steels are of utmost importance to prevent cracks from forming in the base metal and in the deposited stainless steel weld metal.

#### 6.1.6.2 Welding Method

In the case of large items which can be positioned for downhand welding, the series submerged arc method is successfully employed. For smaller items or items which require welding in other than the downhand position, the manual metal arc method with coated electrodes is generally used.

The point to remember in selecting a welding method is to choose the one which gives the minimum amount of penetration into the base metal, thus minimizing the amount of dilution of the deposited weld metal by the base metal.

The use of the inert-gas consumable electrode method has not been very successful because of the rather great amount of penetration into the base metal with subsequent heavy dilution of the first layer of stainless steel with carbon steel. Although there have been some successful overlay jobs with the conventional single wire submerged arc method, there have been cases where the great amount of dilution of the stainless steel weld metal has resulted in cracking.

The series submerged arc method consists of employing converging welding electrodes which feed continuously and which are connected electrically in series to a power source. The location and positioning of the converging welding electrodes are regulated so that a common puddle is formed on the base metal between the electrodes by

the arc which passes from one electrode to the other. In the case of the conventional single wire submerged arc method, the arc is located between the welding wire and the carbon steel base metal, thereby digging into the base metal with considerable dilution of the deposited stainless steel. The deposited weld puddle is protected from the atmosphere by a granular flux. The welding procedure used by one manufacturer of nuclear power equipment states that the angle between the electrodes should be  $45^\circ$  and the intersection of the electrodes  $1/4$  inch above the base metal.

In the case of the manual metal arc method using coated electrodes, more control of penetration is possible than with the single wire submerged arc method and this method has been successfully used on items which cannot be positioned for downhand welding, where an item is too small for series submerged arc welding, or where a small fabrication shop does not have equipment required for other welding methods.

Although there is no reported large scale usage of the inert gas shielded tungsten arc method, there is no reason to expect dilution difficulties if care is exercised. It would be less economical than the other acceptable methods.

#### 6.1.6.3 Welding Electrodes

Although the various competent fabricators of nuclear power equipment have some differences in the specific electrode composition employed for the deposition of the first layer of weld deposited cladding on carbon steel, there is general agreement on the requirements of such an electrode.

- (1) The alloy content of the electrode should be high enough to permit a considerable amount of dilution by carbon steel without developing a brittle martensitic structure.
- (2) The electrode should not be of a composition which gives inherent welding difficulties.
- (3) When a deposit of lower alloy content is deposited over the first layer, dilution of the second layer by the first should not cause difficulties in the second layer.

By use of the constitution diagram for stainless steel weld metal, Par. 6.1.1.2, Figure 1, the maximum safe amount of dilution for various welding electrode compositions can be determined. Welding electrode compositions not presently shown on the diagram can be plotted on the diagram.

### 6.1.6.3 - 6.1.6.4

Specifically, the following electrodes are used:

- (1) For first layer: Type 309, Type 309Mo, or Type 312 are commonly used by various fabricators. Type 309 contains a nominal 25% Cr - 12% Ni, Type 309Mo contains 25 Cr - 12 Ni - 2 Mo, and Type 312 contains a nominal 29 Cr - 9 Ni.
- (2) For the second layer: Type 308, Type 308L, or Type 347 are commonly used, the choice generally being made by the purchaser of the vessel. Type 347 can give difficulties from cracking.

Although Type 310 has been widely used in the past for welding the stainless steels to carbon steel and although it is one of the best compositions with regard to ability to take heavy dilution by carbon steel without forming martensite, the large fabricators of nuclear power equipment do not use it for the two reasons listed below.

- (1) Being a fully austenitic alloy even in weld deposits, it is subject to hot cracking.
- (2) The normally crack resistant Types 308 and 308L (due to their ferrite content) may become fully austenitic and susceptible to cracking if heavily diluted by welding over a first layer of Type 310.

The alloys with lower alloy content such as Types 308 or 308L (nominal 18% Cr - 8% Ni) should not be used as the first layer over carbon steel since they will tolerate little dilution without becoming brittle due to martensite formation.

#### 6.1.6.4 Preheating and Interpass Temperature

The information in Par. 6.1.6.4 through 6.1.6.7 is taken from the procedure specification used by a fabricator of nuclear power equipment. Slight differences are found in procedures used by other fabricators but such procedures are the same in principle.

The preheat temperature for the first layer must be maintained within the range 150°-250°F. For the remaining layers, preheat is not required except when the temperature is below 60°F., then preheat to raise the temperature to within the range 60°-100°F. The interpass temperature for the remaining layers shall not exceed 300°F.

For carbon steel, after depositing the first layer or final layers of cladding, the preheat temperature can be removed prior to stress relieving, providing the following steps are taken: Soak at preheat temperature for four hours before reducing preheat temperature. In no case shall the temperature be allowed to drop below 60°F. before stress relief.

For low alloy steel, after depositing the first layer or final layers of cladding, the preheat temperature shall not be removed prior to stress relieving.

#### 6.1.6.5 Stress Relieving

A stress relief treatment shall be given all overlay welding. This stress relief treatment may be performed after applying the first weld layer alone or after completion of the overlay. If stress relief is conducted after first layer deposition, subsequent layers may be applied without stress relief. (Note: Specifications from other sources require that all layers of the cladding be applied prior to final stress relief.)

Stress relieving details are as follows: Place the welded structure in a uniform temperature furnace not over 500°F. A neutral to slightly oxidizing atmosphere shall be used. In no case shall the atmosphere be carburizing. The surface of the overlay shall be free of carbonaceous material, such as grease, when charged into the furnace. Heat at approximately 100°F. per hour maximum to a temperature of 1150°F.  $\pm$  25°, hold for three hours and cool at 100°F. per hour maximum until the temperature has fallen below 300°F.

#### 6.1.6.6 Inspection

All visual inspection shall be performed using a five power lens or higher. Visual inspection shall be done on completion of the first layer of deposited cladding prior to any stress relieving. Visual inspection shall be given the overlay weld on completion of the remaining layers. After stress relief, the completed overlay as it will be used in the vessel or part, whether it has been finished by machining or grinding or left unfinished, shall be reinspected by the dye penetrant method.

The overlay welding on certain critical components such as tube sheets, shall be ultrasonically tested after the stress relief, final machining and visual inspection operations have been completed.

#### 6.1.6.7 Repair of Defective Areas

Defects such as cracks, porosity (in amounts stated to be rejectable in applicable specifications), and slag filled voids shall be removed and the areas re-welded. All repaired areas are to be reinspected.

Repair welding which does not penetrate through the first stainless overlay weld layer into the base metal does not require stress relief. Any repair welding done on the base metal shall be stress relieved.

## 6.2 - 6.2.3

### 6.2 Brazing

#### 6.2.1 Definition<sup>1</sup>

The term brazing is used to describe a group of welding processes wherein coalescence is produced by heating to suitable temperatures above 800°F. and by using a non-ferrous filler metal having a melting point below that of the base metals. The filler metal is distributed between the closely fitted surfaces of the joint by capillary attraction.

Brazing is distinguished from soldering in that soldering employs a filler metal melting below 800°F. It is important to note that brazing does not include the process known as braze welding. The filler metal used in braze welding is melted and deposited exactly at the point where it is to be used and capillary action is not a factor.

#### 6.2.2 Principles of Operation<sup>1</sup>

The brazed joint, in general, is one of relatively large area and very small thickness. In the simplest and most common application of the process, the surfaces to be joined are cleaned to remove contaminants and loose oxide and are coated with a flux. The latter is a compound which, when molten, is capable of dissolving the solid metal oxides still present. The area is then heated until the flux melts. The joint area thus consists of clean, solid base metal, bridged and protected against further oxidation by a layer of liquid flux.

Filler alloy then is melted at some point on the surface of the joint area. The capillary attraction between the base metal and the filler alloy is several times higher than that between the base metal and the flux. The flux is replaced, therefore, by the filler alloy. The joint, upon cooling to room temperature, will be found filled with solid filler alloy, and the flux, now also solidified, will be found on the outside of the joint. (To avoid some of the corrosion problems associated with the use of fluxes, there is now wide usage of controlled atmospheres to provide a similar function. See Par. 6.2.4).

Brazed joints are usually made with relatively small clearances. The viscosity of the filler alloy, therefore, is almost as important a factor as surface tension and wettability. Low viscosity is a desirable characteristic of brazing alloys since capillary attraction may be insufficient to permit a viscous filler metal to penetrate close-fitting joints.

#### 6.2.3 Brazing For Low and Moderate Temperature Applications

The brazing methods for stainless steel that are familiar to most persons who work with chemical process equipment involve the use of one of the silver brazing alloys, ASTM B-260 Classification B Ag, a corrosive flux to insure that the

brazing alloy will wet the surface of the metal and penetrate the joint, and heating sources such as an oxy-acetylene torch, or induction heating coils. Properly made joints with the silver brazing alloys have good strength at low to moderate temperatures, but are not resistant to many of the corrodents that are handled in stainless steel equipment. This limits their usage to mildly corrosive services in applications where constituents of the brazing alloy, such as copper, cadmium, zinc, or silver, are not harmful to the product being handled. Such brazing alloys when molten may cause intergranular cracking of highly stressed austenitic stainless steel parts. Corrosive fluxes must be completely removed to avoid corrosion of the stainless steel.

In spite of the shortcomings listed above there is considerable usage of the silver brazing alloys for joining stainless steel in small assemblies - especially where mechanical strength is the main consideration. Table 1 gives the compositions of the standard silver brazing alloys and Table 2 the solidus and liquidus temperatures and the brazing temperature ranges. Two standard alloys normally used for higher temperature applications, B NiCr and B AgMn are included in the table.

The following table lists suggested service temperature limits for some standard brazing alloy systems. (The table was taken from the American Welding Society Brazing Manual, Reinhold Publishing Corp., 1955).

<u>AWS-ASTM Filler Metal Classification</u>	<u>Suggested Limiting Temperature For Continuous Service, °F.</u>	<u>Suggested Maximum Service Temp. °F.</u>
B Ag	400	500
B CuZn	400	500
B Cu	400	900
B AgMn	500	900
B NiCr	1000	2000

#### 6.2.4 Brazing For High Temperature Applications

With the advent of jet engines and rockets, there have been rapid advances in the art of brazing for high temperature applications. Many of the recently developed alloys are suitable for the brazing of the austenitic, ferritic, and precipitation hardening stainless steels.

High temperature alloy brazing is a fluxless method of metal joining. For best results, high temperature brazing alloys should meet three basic requirements.

- 1) They should melt in the range of 1850° to 2200°F.

#### 6.2.4

- 2) They should produce good wettability - the ability to spread over a base metal surface while superficially diffusing into, and alloying with it.
- 3) They should have oxidation and corrosion resistance comparable to the high temperature alloys being joined.<sup>2</sup>

The chemical composition of a high temperature brazing alloy is both unusual and transient - transient, because it is altered during the brazing reaction. The brazing alloy composition and structure after brazing depend on the nature and extent of diffusion between brazing alloy and base metal. This ultimate composition may be altered by variations in diffusion rates produced by superheating, by time at temperature, and by composition of the base metal.<sup>2</sup>

To avoid excessive fusion and overheating of the base metal during brazing, high temperature brazing alloys must melt within a fairly narrow temperature range (1850-2200°F.) Eutectic or near-eutectic compositions must be selected to get base compositions that approach this melting range. When required, additional elements must be added to lower further the melting temperature.<sup>2</sup>

Nickel is usually selected as a base for these brazing alloys. There are a number of nickel binary eutectics which have relatively low melting points. Such alloys can be expected to bond with iron base alloys (stainless steels) chromium, cobalt, molybdenum, and nickel base alloys to form nickel-rich solid solutions at the brazed joint interface. Additional elements are added to the binary composition to produce a composition having a melting range within 1850° to 2200°F. Elements added to nickel to make up high temperature brazing alloys include chromium, silicon, phosphorus, carbon, and boron. Gold and cobalt have been used to a limited extent.<sup>2</sup>

Some additional information about the nickel base brazing alloys and other high temperature alloys is listed below:

- 1) Nickel-Silicon-Boron and Nickel-Chromium-Silicon-Boron:  
This group of alloys contains mainly nickel, with silicon and boron as the other alloying elements. In addition, in two of the alloys part of the nickel is replaced with chromium to provide superior oxidation and corrosion resistance. In hardness and strength retention in the 1600° to 1800°F. range, these high nickel materials are unsurpassed. However, they do attack many base metals by intergranular penetration and solution. (This general class of alloys is covered by AMS specifications 4775 through 4778 and one of the alloys is covered by ASTM B-260 Classification B NiCr). The best known trade name for the general class of alloys is Nicrobraz\*, but other manufacturers supply similar alloys to meet AMS and ASTM specification requirements.<sup>3</sup>

\*Registered Trademark of Wall Colmonoy Corp.

- 2) Manganese-Nickel: Manganese-nickel (70%-30%) is used for successfully joining stainless steel, Inconel and other heat resistant alloys. At elevated temperature it retains much of its high joint strength (55,000-65,000 psi at room temperature). It offers better oxidation resistance than silver-copper-lithium or silver manganese.

Its properties fall midway between the latter two fillers and the nickel-chromium-silicon-boron filler metals. That is, in oxidation resistance, it is better than the high silver fillers, but not as good as the Ni-Cr-Si-B group. On the other hand, it has much less tendency to dissolve or penetrate the base metal (highly undesirable with thin sections) than do the high nickel alloys.<sup>3</sup>

- 3) Silver-Base Lithium Alloys: Recent research confirmed by industry experience shows that addition of a small percentage of lithium markedly improves the fluidity and wetting ability of many standard alloys. The lithium alloys typically contain 0.2% lithium. One such filler metal - sterling silver with lithium - is gaining favor for brazing 17-7 PH stainless steel honeycomb panels. Joints retain a tensile strength of about 35,000-40,000 psi (short-time test) at 900°F.

Other fillers in which the addition of small amounts of lithium has proved advantageous are the silver-copper eutectic, AMS 4772, and silver-Manganese (85%-15%), ASTM B-260, Classification B AgMn. These are used to braze stainless steel bellows, instrument assemblies, hydraulic lines and a variety of jet engine parts.<sup>3</sup>

- 4) Silver-Palladium and Silver-Palladium-Manganese: Palladium additions to silver increase the melting temperature, the strength and the ability to wet iron and nickel-base alloys. Manganese further improves the wetting. These alloys do not penetrate or dissolve the base metal to any extent. Joints of these alloys have been reported to be less susceptible to crevice corrosion attack than those made with silver-manganese alloys. Their resistance to oxidation is similar to other silver base alloys.<sup>3</sup>
- 5) Gold Alloys: In situations where intergranular penetration of the base metal cannot be tolerated, and where high strength and excellent oxidation resistance are required at temperatures around 1600°F., there is strong interest in gold alloys. Compared with the high nickel alloys, the gold alloys have lower hardness, better ductility and less tendency toward intergranular penetration.

Lap joints between Inconel and stainless steel, brazed with gold-nickel-chromium filler in a helium atmosphere at 1900°F. without flux, were exposed to air at 1600°F. for a period of 88 hours with no adverse effect. Still

## 6.2.4

other joints, brazed in stainless steel with the same filler and heated in air for seven days at 1600°F., retained a tensile strength of 20,000 psi when tested at 1600°F. This is considered excellent performance at this temperature.

Some of the advanced applications for which these gold filler metals are being considered include components for rocket motors, missiles, nuclear reactors and supersonic aircraft.

Table 3 lists some commercially available nickel base brazing alloys. Table 4 lists some commercially available noble-metal brazing filler metals. Tables 3 and 4 and the following paragraphs on atmospheres are taken from DMIC Report 149, "Brazing For High Temperature Service", Defense Materials Information Center, Battelle Memorial Institute, Feb. 21, 1961.

With few exceptions, the heat-resistant base materials must be brazed in a special atmosphere to protect them from oxidation. In order to insure well brazed joints, it is necessary to have extensive knowledge of the base metal characteristics at high temperatures. In particular, the refractory metals are very susceptible to oxidation and even small concentrations of these metals in the heat resistant alloys affect their brazing properties adversely. Care must be exercised in the selection of the protective atmosphere. For example, some metals, such as titanium and zirconium, have a natural affinity for hydrogen and will become embrittled in such an atmosphere.

Many of the heat resistant alloys can be successfully brazed in atmospheres of dry argon or helium. This is particularly true if the surface oxides can be removed readily and if the parts can be transferred to the furnace in an uncontaminated condition.

Hydrogen atmosphere is widely used for high temperature brazing because hydrogen reduces many of the metallic oxides, and a clean surface is presented for brazing.

Much of the brazing performed in the aircraft and missile industry is done in a vacuum because of the particular metals being brazed or because of the nature of the manufacturing process.

There are many important considerations in brazing with the alloys used for high temperature applications. These include joint design, special preparation of surfaces to be joined, placement of brazing alloy, use of fixtures for supporting work in furnace, and inspection of the brazed joint. Where the use of brazing appears to be a suitable method for the fabrication of a particular equipment item, it is recommended that details be worked out by a person experienced in the brazing field to avoid serious and sometimes insurmountable fabrication problems at a later date.

### 6.2.5 Applications

Since the corrosion resistance of brazing alloys is generally inferior to that of the austenitic stainless steels in nitric acid service there has been practically no usage of brazing in the fabrication of equipment for Savannah River Plant for severely corrosive services. There have been some applications in equipment for mildly corrosive or non-corrosive services, including the use of Ni-Cr-Si-B brazing alloy for joining items of Type 410 stainless to form some 12,000 psi strain cells. Previously a welded strain cell design had failed by fatigue from a notch formed by incomplete penetration of a weld. There is extensive use of brazing in the aircraft, rocket and missile fields.

For items which will be used in non-corrosive or mildly corrosive environments, even at elevated temperatures, brazing should be considered in the following instances:

- a) Where the design of relatively small parts is such that certain surfaces to be joined are inaccessible for welding.
- b) Where the stress raisers, shrinkage, or high stresses resulting from welding cannot be tolerated.
- c) Where thick and thin sections must be joined in complicated, close tolerance assemblies.
- d) Where a large number of relatively small assemblies must be fabricated.

#### Sources of information:

1. Welding Handbook, Fourth Edition, American Welding Society, 1960.
2. Feduska, W., "Guide To Better High-Temperature Brazing", The Iron Age, May 16, 1957.
3. Setapen, A.M., "5 New Brazing Alloys For High-Temperature Service", Industry & Welding, May, 1958.

Table 1  
SILVER BRAZING ALLOYS, ASTM B-260 CLASSIFICATION B Ag  
CHEMICAL COMPOSITION

<u>AWS-ASTM Classification</u>	<u>Silver %</u>	<u>Copper %</u>	<u>Zinc %</u>	<u>Cadmium %</u>	<u>Nickel %</u>	<u>Tin %</u>
B Ag-1	44-46	14-16	14-18	23-25	-	-
B Ag-1a	49-51	14.5-16.5	14.5-18.5	17-19	-	-
B Ag-2	34-36	25-27	19-23	17-19	-	-
B Ag-3	49-51	14.5-16.5	13.5-17.5	15-17	2.5-3.5	-
B Ag-4	39-41	29-31	26-30	-	1.5-2.5	-
B Ag-5	44-46	29-31	23-27	-	-	-
B Ag-6	49-51	33-35	14-18	-	-	-
B Ag-7	55-57	21-23	15-19	-	-	4.5-5.5
B Ag-8	71-73	27-29	-	-	-	-
B Ag-9	64-66	19-21	13-17	-	-	-
B Ag-10	69-71	19-21	8-12	-	-	-
B Ag-11	74-76	21-23	2.5-3.5	-	-	-

Table 2  
BRAZING ALLOYS, ASTM B-260, CLASSIFICATION B Ag, B Ni, Cr, AND B AgMn  
SOLIDUS, LIQUIDUS, AND BRAZING TEMPERATURE RANGES

<u>AWS-ASTM Classification</u>	<u>Solidus °F.</u>	<u>Liquidus °F.</u>	<u>Brazing Temperature Range, °F.</u>
B Ag-1	1125	1145	1145-1400
B Ag-1a	1160	1175	1175-1400
B Ag-2	1125	1295	1295-1550
B Ag-3	1170	1270	1270-1500
B Ag-4	1240	1435	1435-1650
B Ag-5	1250	1370	1370-1550
B Ag-6	1270	1425	1425-1600
B Ag-7	1145	1205	1205-1400
B Ag-8	1435	1435	1435-1650
B Ag-9	1280	1325	1325-1550
B Ag-10	1335	1390	1390-1600
B Ag-11	1365	1450	1450-1650
B NiCr	1850	1950	2000-2150
B AgMn	1760	1780	1780-2100

TABLE 3 SOME COMMERCIALY AVAILABLE NICKEL-BASE BRAZING ALLOYS

Alloy	Composition, per cent						Brazing Temperature, F	AMS Number
	Ni	Cr	Si	B	Fe	Other		
1	93.25		3.5	2.25		1	2000	4778
2	91.85		4.5	2.65		1	1900	
3	91.25		4.5	3.25		1	1900	
4	91.8		4.5	3.5		0.2C	1875	
5	93.25		3.5	1.9		1.35	1930	
6	91.25		4.5	1.9		2.35	1820	
7	72.5	15	5	3.5	3	1	2100	4775
8	71.25	16	4	3.75	4	1	1880	
9	72.5	16	5	3.5		3	1840	
10	73.2	13.5	4.5	3.5	4.5	0.8C	2150	
11	73.85	13.5	4.5	3.5	4.5	0.15C	2150	4776
12	82.1	7	4.5	2.4	3	0.5	1925	4777
13	82	7	4.5	2.9		4.1	1825	
14	83.25	6	5	3	2.5	0.15C	1900	
15	67-73	16-20	3-10			3	2150	
16	77-81		9-11			8-10P	2100	
17	85-87.5		4-5			5.5-7P	1850	
18	71-77	11-15				9-10P	1800	
19	70-76		8-10			13-17Mn	2050	
20	80		16			4	1850-2150	
21	81.45	15		3.4		0.15C		
22	75-85	8-14	1.25-3.5	2-3	1.25-3.25	0.3-0.06C-1.50Co	1780-2120	
23	86-88					10-12P	1800	
24	85-87		11-13				2125	
25	36.5		5	3.5	20	35Co	1900	
26	50	0.5	12		28	4Mo-4.5P-1Mn	2050	
27	41	5			35	10P-2Cu-7Co	1900	
28	40		2.2	1.7	35	9P-2Cu and Co	1900	
29	42				35.75	11P-7.75Co	1900	
30	66	19	10		4	1Mn	2150	
31	30					70Mn	1950	
32	56	16	10			24Pd	1900	
33	45	10	9			36Pd	1900	
34	78.35	11.5	3.5	3.0	3.5	0.15C	2100	
35	62.45	11.5	3.25	2.5	3.75	16W-0.55C	2150	
36	72.2		4.5	3.30		20Co	1950	
37	90.15		4.0	3.30	1.80	0.75Ti	1950	
38	67.00	20.0	10.0		3.00		2150	
39	16.00			1.00		16Co-67Mn	1950	
40	71.00	19.0	10.0				2150	
41	61.00	19.0	10.0			10Mn	2100	
42	21.0	21.0	8.0	0.80		0.4C-4.0W-45.8Co	2175	
43	38.0	33.0	4.0			25Pd	2150	
44	77.2	15.2	8.0				2175	
45	73.62	17.1	9.2	0.08			2125	
46	31.5	11.4	6.8	0.3			2125	
47	73.87	13.3	7.6	0.23			2125	
48	93.6	2.2	2.6	1.6			2050	
49	92.6	2.7	2.8	1.8			2050	

TABLE 4 SOME COMMERCIALY AVAILABLE NOBLE-METAL BRAZING FILLER METALS

Alloy Type	Composition, per cent										Brazing Temperature, F
	Ag	Au	Pd	Cu	Ni	Mn	Cr	Li	Al	Pt	F
Ag	100										1825
AgCu	72			28							1500
AgCu	50			50							1650
AgCuLi	92.3			7.5				0.2			1635
AgCuLi	89.5			10				0.5			--
AgCuLi	92.5			7				0.5			--
AgCuLi	71.5			28				0.5			1500
AgLi	98							2			1475
AgAl	95								5		1675
AgCuNi	77			21	2						1600
AgCuNi	75			24.5	0.5						1500
AgCuNi	62.5			32.5	5						1700
AgCuNi	71.5			28	0.5						1535
AgCuNiMn	65			28	2	5					1520
AgCuPd	54		25	21							1810
AgCuPd	68		5	27							1560
AgCuPd	58		10	32							1635
AgCuPd	65		15	20							1725
AgPd	95		5								1925
AgPd	90		10								2025
AgPd	80		20								2225
AgPd	70		30								2190
PdNi			60		40						2325
AgPdMn	75		20			5					2125
AgPdMn	64		33			3					2265
AgPdAl	14.5		80						5.5		2050
AgPdPt	91.8		6.0		0.1			0.1		2	--
AgMn	85					15					1875
AgMnLi	84.5					15		0.5			1875
PdNiMn			21		48	31					2125
AuCu		94		6							1875
AuCu		66.7		33.3							1760
AuCu		20		80							1955
AuNi		82.5			17.5						1875
AuAgCu	20	60		20							1625
AuAgCu	5	75		20							1725
AuCuNi		81.5		15.5	3						1745
AuCuNi		35		62	3						1960
Au	100										2020
AuPd		87	13								2450
AuPd		75	25								2635
Pd			100								2900
PtPdAu		5	20							75	3150
Pt										100	3290
AuNiCr		72			22	6					1835

## 6.3 Soldering

### 6.3.1 Definition<sup>1</sup>

Soldering is defined as a joining process wherein coalescence between metal parts is produced by heating to suitable temperatures generally below 800°F. and by using nonferrous filler metals (solders) having melting temperatures below those of the base metal. The solder is usually distributed between the properly fitted surfaces of the joint by capillary attraction.

### 6.3.2 Applications

Because of the relatively low strength and poor corrosion resistance of the soft solders there are few applications in chemical processing equipment where soldered joints are acceptable. An example of an application where the use of soldered joints might be acceptable is a stainless steel cabinet where leak tight joints with sealed crevices and rounded corners are desired, but where corrosive atmospheres are not encountered.

### 6.3.3 Joint Design

Soldered joints should be of the lap type. Where the lap joints in sheet metal will be subjected to stress or flexing in service, they should be riveted laps or lock seams so that the function of the solder will be limited to sealing against leakage and filling the crevice rather than providing mechanical strength. Pretinning of the sheets from which the lap joints are formed is employed to facilitate flux removal.

### 6.3.4 Fluxes<sup>2</sup>

There are numerous fluxing materials commercially available for soft soldering stainless. Because of the high degree of corrosion resistance exhibited by the protective film on the various grades of stainless, the fluxes have to be strongly corrosive in character. Fluxes of hydrochloric acid base are commonly employed for that reason. Zinc chloride is a commonly used fluxing material. Another very strong etchant that is used on occasions as a fluxing material contains hydrochloric acid, nitric acid, and ferric chloride. It is obviously essential that these fluxing materials be completely removed from the surface of the stainless steel. This subject is discussed in Par. 6.3.7.

### 6.3.5 Solders

Table 1 gives compositions and melting points of the lead-tin soft solders which are commonly used for soldering of

### 6.3.5 - 6.3.7

stainless steel. When these solders were tested in bulk form, not in bonded form, it was found that elongation and impact strength reached a maximum at around the 50% tin-50% lead composition, and that tensile and shear strengths reached a maximum around the 63% tin-37% lead composition. Since most soldered joints do not rely solely on the strength of the solder, mechanical properties of a particular solder are not a primary consideration. With regard to flow points, it will be noticed that the eutectic alloy 63% tin and 37% lead possesses the lowest melting point at 361°F., at which temperature the alloy melts sharply. Other grades exhibit a pasty or plastic range beginning at 361°F. and do not become fully molten until higher temperatures, as shown in Table 1, are reached. Where joint clearances are large it is advantageous to use a solder with a plastic range rather than the sharply melting composition to avoid loss of solder through the joint.

The tin-lead solders are unsatisfactory for use on soldered joints for service temperatures above 300°F. under sustained loads. A 95% tin-5% antimony solder, which becomes plastic at 452°F. is sometimes used where a little better strength at slightly elevated temperatures is required.

#### 6.3.6 Application of Solder

Although the soldering of stainless steel parts is on many occasions performed with soldering irons, gas flame, induction heating, etc., as is common for the soldering of other metals, the necessity for complete removal of flux residues makes pretinning an attractive method. By the use of pretinning, the parts to be joined are coated with solder individually. A corrosive flux may be used if required, since there are no crevices to retain the flux during the subsequent cleaning operation. After the parts have been cleaned, they are assembled and heated for making the final joint, with addition of more solder if necessary. If a flux is required at this stage, it can be of a noncorrosive type.

#### 6.3.7 Flux Removal<sup>2</sup>

An all important rule in joint design is to make certain that it is possible to remove residual flux upon completion of soldering. Accessibility must be provided on all surfaces of a joint.

As the corrosive action of strong fluxes does not cease upon completion of soldering, it is vitally important to remove all residues promptly and thoroughly. The necessity for this cannot be overemphasized. Any residue of flux constitutes a continuing hazard. Even though thoroughly dried on

completion of a job and thus rendered inactive, any subsequent pickup of moisture (as from the atmosphere) will re-activate the flux, the eventual result of which will be failure of the soldered zone by corrosive attack.

Thorough washing is necessary for complete flux removal. Diligent scrubbing may also be called for. Washing should be done in clean, flowing hot water (not in a stationary tank on account of the danger of build-up of bath contamination). Added insurance is afforded by the use of a slightly alkaline neutralizing bath, followed again by thorough hot water washing.

#### 6.3.8 Solder Specifications

ASTM B32-60aT, Solder Metal, gives compositions of tin-lead, tin-lead-antimony, tin-antimony, and silver-lead solders.

ASTM B284-60T covers rosin flux cored solder.

#### Sources of Information:

1. Welding Handbook, Section 3, American Welding Society, 1959.
2. "Stainless Steel Fabrication", Allegheny Ludlum Steel Corp., 1959.

6.3 Table 1

Table 1 - Soft Solders -  
Relationship Between Composition and Melting Characteristics<sup>2</sup>

<u>Solder Analysis</u>		<u>Becomes Plastic at °F.</u>	<u>Melting Point, °F.</u>	<u>Remarks</u>
<u>% Tin</u>	<u>% Lead</u>			
0	100	-	620	
50	50	361	414	Will darken rapidly
60	40	361	370	)
63	37	(Eutectic alloy melts sharply)	361	)Most generally used )with stainless steel, )except where higher )tin types are preferred.
65	35	361	364	
70	30	361	367	
80	20	361	390	
90	10	361	415	
100	0	-	450	

## 6.4 Thermal Cutting

### 6.4.1 General

In this section the newer methods of cutting, such as "Heliarc"\* cutting, are described and compared with the older methods such as oxyacetylene.

### 6.4.2 Oxygen Gas Cutting

#### 6.4.2.1 General Description of Process

The oxygen cutting method is universally used, being applicable to innumerable jobs. Most maintenance shops employ this type of equipment because the quality of the cut is good and, in most instances, this method of cutting is more economical than other methods.

#### 6.4.2.2 Cutting Operation

Essentially, the cutting of iron or steel by the oxygen cutting process merely involves the direction of a jet of pure oxygen onto an area that is preheated, with the preheat flame surrounding the cutting oxygen jet.

In all oxygen cutting, the preheating flames are first turned on and directed to the edge of the metal where the cut is to be started. The edge is heated until a bright red spot appears. The cutting valve is then opened and, with the preheat flames still burning, the torch is advanced at a steady rate with as little wavering as possible along the line of cut. If the speed of travel is too great, the slag and oxide emerging from the bottom of the cut will trail back at an angle. When this is the case, a poor-quality cut usually results and there is danger of the stream suddenly failing to penetrate the steel. The proper speed of cutting may be determined by a slight drag in the oxide emerging stream. In other words, the oxide stream at the base of the cut should trail the cutting tip slightly.

In Table 1, data for hand-cutting carbon steel 1/8 inch to 12 inches thick with oxyacetylene is shown. Machine cutting speeds and gas consumptions are similar to those shown in Table 1 except that the cutting oxygen pressures and speeds are slightly higher.

The process of cutting is mainly one of rapid oxidation of the metal. In cutting carbon steels, the oxides formed have melting temperatures which are lower than the melting point of the steel. Thus, the oxides melt off as fast as formed and do not hinder the oxidation process. Materials such as stainless steels, cast iron, aluminum bronzes, and "Hastelloy" alloys are difficult to cut by the oxygen process. The

\*"Heliarc" is a registered trademark of Union Carbide Corp.

#### 6.4.2.2 - 6.4.2.4

reason is that the oxides formed have melting temperatures which are higher than the melting point of the parent metal. An insulating coating of oxides thus formed hampers and, in the case of some oxides (such as chromium oxide on stainless steel), completely stops the oxidation process. The cutting of these more difficult materials will be discussed under powder cutting, arc oxygen cutting, and "Heliarc" cutting.

#### 6.4.2.3 Fuel Gases Used

Acetylene, propane, and butane are the most commonly used fuel gases.

Acetylene is the most widely used fuel for cutting. It is readily available, easy to handle, and it has the highest combustion intensity which permits a fast start and generally more efficient cuts on materials up to 12 inches thick.

Propane is being used at a number of plants because of its relatively low cost in large quantities and where it also is used for purposes other than cutting. However, for proper combustion, propane requires about four to five times its volume of oxygen, to some extent offsetting the economic benefits in light cutting. However, in heavy cutting and heavy scrap work, propane is usually more efficient.

Since acetylene is the most widely used fuel gas because of its availability, ease of handling, and high combustion intensity, the following remarks will concern oxyacetylene cutting only.

#### 6.4.2.4 Equipment Used

The source of gas supply can be pipeline, manifold, or cylinder. The pressure regulators are attached to these sources. The regulators employed are similar to those used for welding operations. For the majority of cutting operations, the oxygen consumption is large, making it essential to use a regulator capable of supplying large flows at the correct pressure.

A torch is connected to the gas supply by hose lines of sufficient size to conduct the volume of gases necessary for the cutting operation without excessive pressure drop. The hose lines are, in turn, connected to the outlet of the two pressure regulators (one for the fuel gas and one for the oxygen).

Several types of torches are employed in oxygen cutting. For manual cutting, a welding torch with a cutting attachment (or a hand-cutting torch) may be employed. These torches are not readily adaptable for machine cutting. Machine cutting equipment is generally purchased as a packaged unit.

Most cutting torches on the market are dependable, and no specific type is recommended.

Portable machines usually travel on a straight section of track, which performs the function of guiding the torch along the line of cut. These machines are widely used in the preparation of plate for welding (square cut or bevel), for ripping plate, and other purposes requiring a straight line cut. An attachment with an adjustable radius arm permits cutting circles.

### 6.4.3 Arc Cutting

#### 6.4.3.1 General Description of Processes

Arc cutting is based on the conversion of electrical energy into heat within the confines of an electrical arc maintained between the work and the electrode. Because of the extremely high temperature developed in the electrical arc, it can be used to fuse almost any material that conducts electricity, and is employed for cutting metals. Arc cutting does not equal gas cutting from the standpoint of smoothness, quality, or accuracy of cut surfaces, and is not used where high-quality accurate cuts are required. It is useful where smooth, uniform cut surfaces are not essential and where severing is the main object, as in scrapping operations. Arc cutting also is used for metals not easily cut in any other manner, such as cast iron, manganese steel, and large sections of nonferrous metals. Three procedures are employed, namely, the carbon-arc, metal-arc, and arc oxygen methods.

#### 6.4.3.2 Carbon-Arc Cutting

The carbon-arc method uses direct current straight polarity. This method is not very extensively employed but may be used when other cutting equipment is not available. Although alternating current may be used, it is much more difficult to control. Graphite electrodes are preferred to carbon electrodes because they have a much longer service life and retain a point longer. A point is essential for clean, smooth cuts. The heavy currents used for arc cutting make ordinary electrode holders unsuitable except for light work. Special holders are recommended that have a long shank, a special mechanism for gripping, and a shield for protecting the hands. For currents in excess of 300 amperes, water-cooled carbon electrode holders are desirable.

Recommended current values for graphite electrodes of different sizes are:

#### CURRENT VALUES FOR ARC CUTTING

Electrode Dia (in.)	Current (amp)
1/4	200 or less
3/8	200 to 400
1/2	300 to 600

#### 6.4.3.2 - 6.4.3.4

Electrode Dia (in.)	Current (amp)
5/8	400 to 700
3/4	600 to 800
7/8	700 to 1000
1	800 to 1200

Manipulation of the cutting arc, when cutting plates 1/2 inch thick or less, consists in advancing along the line of cut at a rate equal to that at which the metal is being melted away. The most smooth and uniform cuts are made when the plate is in a horizontal plane, but the operation may be performed when the plate is in an inclined or vertical position. For horizontal cutting, the electrode is held vertical or pointed slightly forward. For inclined or vertical cutting, the electrode is pointed downward. When metals heavier than 1/2 inch are being cut, the vertical face of the cut is melted away progressively from top to bottom. Thus, the bottom of the cut is advanced slightly ahead of the top of the cut, producing an undercut that permits the molten metal to run out more easily. Skilled operators can make narrower cuts. The width and speed of the cut increases with the current and diameter of the electrode.

#### 6.4.3.3 Metal-Arc Cutting

The metal-arc procedure employs covered carbon steel welding electrodes.

The application of heavily coated electrode to cutting is not always an economical process, but has certain merits, particularly where no oxyacetylene torch or graphite electrode is available. Electrodes especially designed for cutting are available, such as "Cuttrode," a coated electrode manufactured by the Eutectic Welding Alloys Corporation. The concentrated arc is advantageous in hole-piercing operations. Another advantage of the coated electrode is that there is no danger of excessive carbon pickup, as in the case with the carbon electrode.

Plates 1/2 inch thick or less can be cut by advancing the electrode along the line of cut. On heavier plates, the electrode is pointed forward and moved from the top to the bottom of the cut so as to keep the bottom slightly ahead. The width of the cut is approximately constant for all electrodes 1/4 inch in diameter or less. For performance, see Table 2.

The cut produced by metal-arc cutting is less ragged than in carbon-arc cutting but, generally, it is not satisfactory in the preparation of parts for welding without considerable trimming by chiseling or grinding.

#### 6.4.3.4 Arc-Oxygen Cutting

The arc-oxygen procedure employs tubular electrodes; the arc

serving to heat the metal to be cut to incandescence. The oxygen stream issuing from the bore of the electrode ignites the incandescent metal, and the kinetic energy of the oxygen stream expels the products of combustion and produces the cut.

The tubular electrodes used in arc-oxygen cutting are covered with an electric insulating material to permit insertion into deep gaps when necessary. Direct current, straight polarity is preferred. The function of the metal electrode is to conduct current and maintain an arc of sufficient intensity to produce incandescence, when following manufacturers recommended amperage for a specified electrode size.

The tubular steel electrodes are available from Arcos Corporation in lengths of 18 inches and 14 inches with 3/16-inch and 5/16-inch diameters, respectively. The tubes are either seamless drawn or of open-seam construction. A special electrode holder is required for this use.

In arc-oxygen cutting there is normally no manipulation. When cutting in air with 3/16-inch or 5/16-inch diameter steel tube core electrode, the technique is to drag the electrode along the intended line of cut applying slight pressure.

Arc-oxygen cutting devices may be used as standby shop equipment or to complement oxygen-cutting torches; particularly for piercing steels, cutting cast iron, nonferrous metal, stainless steels, and loosely joined plate or sheet assemblies.

#### 6.4.3.5 "Arcair"\* Cutting

In "Arcair" cutting, copper-coated graphite electrodes are used in an electrode holder similar to a conventional jaw-type holder (for welding with coated electrodes). The electrode holder has air jets arranged to direct compressed air directly behind the electrode by pressing a valve in the holder handle. Because of the compressed air in contact with the electrode, oxidation is rapid, and an uncoated electrode would be rapidly consumed. The copper coating on the graphite electrodes used with this process greatly extends the life of the electrode, as it dissipates heat readily while retarding the burning away of the graphite through oxidation.

For removing defective welds, for plate edge preparation for welding, or for making grooves in plate, this process is very useful. It cannot make cuts comparable to oxyacetylene cutting. Equipment cost is nominal, and it will cut or gouge all metals, making it an attractive tool in shops where cost of powder-cutting equipment cannot be justified.

To operate the torch, the electrode is gripped with not less than 4-1/2 to 5 inches of the electrode extending beyond the holder jaws. The arc is struck where it is desired to start

\*"Arcair" is a tradename of the Arcair Company

#### 6.4.3.5 - 6.4.4

the groove. The air valve is opened before striking the arc. The molten puddle is blasted away by the jets of air, and the arc is moved ahead at the rate of speed required to produce a cut of the desired depth. The tip of the electrode is held lightly in contact with the material being cut, and is tilted slightly away from the direction of travel. Electrodes should not be burned down closer than 3 inches from the holder as the excessive heat will damage the holder jaws. The width of the cut is approximately  $1/2$  inch to  $3/4$  inch depending upon electrode size and amperage, and speed of travel. Groove depth should not exceed  $1/4$  inch per pass. If deeper grooves are desired, a number of passes are required. With a little practice, an operator will gain the proficiency to make smooth, regular cuts.

Most of the molten metal is blown away from the cut during the gouging operation, but some slag (in the form of solidified droplets of metal) adheres to the edges of the groove. The slag is removed from the cut or groove as easily as is the slag from conventional flame cutting.

There is some carbon pickup in the metal adjacent to the cut or grooved surface with this process. This is not usually detrimental in carbon steel, cast iron, or some nonferrous metals such as aluminum, copper, bronze, etc. Carbon pickup, however, is objectionable in stainless steels, nickel, "Monel," "Inconel," and certain other metals and alloys. Laboratory tests have proven the extent of carbon pickup does not exceed  $1/32$  inch. Where carbon pickup cannot be tolerated, grinding of the cut surfaces to a depth of not less than  $1/32$  inch should be done.

#### 6.4.4 Powder-Cutting Process

The purpose of powder cutting is to raise the temperature in the kerf by the heat liberated by the reaction between the powdered iron and cutting oxygen. The powder used is a fine iron-rich powder, carried under pressure by air or nitrogen to an annular space surrounding the machine cutting blowpipe nozzle or, in the case of the hand-cutting blowpipe, the powder is injected into the cutting oxygen in the nozzle of the blowpipe. The powder is held in either an aspiratory-type or vibratory-type feeder, of which the latter is the better of the two. The oxygen and acetylene gases are introduced into the torch in the same manner as in a standard oxyacetylene torch. The burning iron powder liberates a great quantity of heat that melts the oxides which do not melt in the ordinary oxyacetylene flame.

The operation is the same as for cutting mild steel, except that the powder flow is turned on with the cutting oxygen. Since extreme heat of reaction is available immediately, the preheat period is considerably reduced and, in many cases, a "flying start" can be made. During cutting, products of combustion are given off in a heavy smoke cloud. Suitable arrangements should be made to remove fumes given off during cutting. Probably the best way is to use air-exhausting

equipment but, if this is not practical, cutting should be done in the open air or the operators should use respirators.

In both hand and machine cutting, the blowpipe is held considerably higher above the surface of the plate than is usual for mild steel. It is important to maintain a regular flow of powder according to the amount required (15-100 pounds per hour) for the thickness being cut. Too little powder stops the cut and too much causes overheating, leading to an inferior cut edge with excessive slag. It is important that the powder be kept dry during storage in the dispenser and, in fact, right up to the nozzle. The compressed air used also must be completely free of moisture and very often compressed nitrogen from a cylinder is used instead of air, because of its greater freedom from dampness. The air or nitrogen pressure is 2-10 pounds per square inch.

There is a greater slag build-up than for the oxyacetylene cutting of mild steel, which is tightly adhering, with a bead of fused powder on the top edge. While welds have been made on the "as cut" surface of stainless steel without removing scale, this practice is not recommended.

One of the outstanding advantages of this process is that it can cut almost any material. All grades of stainless steel, cast iron, "Hastelloys"\*, "MONEL" alloy 400†, Nickel alloy 200, "INCONEL" alloy 600†, copper, etc can be cut. On the higher alloys of stainless and nonferrous materials, a special powder containing aluminum is employed. Actually, in cutting nonferrous and high-alloy steel (containing less than 50 percent iron), the process is a controlled melting operation.

National Cylinder Gas Company has been licensed by Linde to manufacture equipment of this process. The process is called the "Ferro-Jet Cutting" by NCG.

#### 6.4.5 "Heliarc" \*\* Cutting

In "Heliarc" cutting, an extremely high-temperature arc is maintained between a tungsten electrode and the work piece. A constricted arc is obtained by recessing the electrode 1/8 inch back from the nozzle, which has an opening of 1/8 inch or 5/32 inch, depending upon nature of metal to be cut, cutting speed desired, etc. An argon-hydrogen gas mixture flows at high velocity through the nozzle. The concentrated and columnated energy of the arc stream, in combination with the high velocity of the gas, melts and ejects a thin section of metal to form a kerf. The molten metal is removed mechanically and the inert gas prevents oxidation of the kerf walls.

\*"Hastelloy" is a registered trademark of Union Carbide Corp.

\*\*"Heliarc" is a registered trademark of Union Carbide Corp.

† MONEL and INCONEL are registered trademarks of the International Nickel Co.

## 6.4.5

A very attractive feature of this process is its ability to cut all metals. Speed of cutting is, in general, comparable to that for oxyacetylene cutting of carbon steel. Speed varies with the material to be cut. It is possible, for example, to cut 1/4 inch thick aluminum plate at a speed of 300 inches per minute, while the speed for cutting stainless steel of the same thickness is about 60 inches per minute. When using the argon-hydrogen gas mixture for carbon steel or stainless steel, a dross (in the form of solidified droplets) adheres to the opposite edge of the kerf. The dross may be removed by chiseling or grinding. Other metals are cut clean. There is no contamination of the cut surfaces.

A high-frequency unit is used with a pilot-arc circuit to initiate the cutting arc. The high-frequency spark ionizes a path for pilot-arc current between the electrode and the nozzle. Ionized gas from the pilot arc provides the low-resistance path for the cutting arc. A high-frequency unit of higher capacity than that used for "Heliarc" welding is needed, as argon-hydrogen gas mixtures are not as readily ionized as the pure argon or helium used in welding. For the same reason, voltage requirements are greater than for welding operations. It is necessary to have an open-circuit voltage of not less than 90 volts and a closed-circuit voltage of about 70 volts, which is considerably higher than conventional rectifiers will deliver. A 600-ampere motor generator set especially designed for this use is recommended. If a conventional generator unit is considered for use, not less than 400-ampere capacity should be used.

Because of the fluctuations in arc length which is characteristic of manual cutting, it is necessary to use a gas mixture consisting of 20 percent hydrogen and 80 percent argon. In machine cutting, where uniform arc length may be maintained, the gas mixture is 35 percent hydrogen and 65 percent argon.

Cost of equipment for "Heliarc" cutting, exclusive of power source, was approximately \$1200 in early 1960. "Heliarc" is one of the most attractive developments in thermal cutting to date, and should have considerable application in Company construction and maintenance fabrication work.

**SAFETY NOTE:** Because of the higher voltages used in this process, it is important that operators be instructed not to touch or adjust the electrode without disconnecting the power source.

TABLE 1. DATA FOR HAND CUTTING OF CLEAN, MILD STEEL  
 1/8 INCH TO 12 INCHES THICK (NOT PREHEATED)

Thickness of Steel (in.)	Dia. of Cutting Orifice (in.)	Cutting Speed (in. per min) *	Gas Consumption (per linear ft.)	
			Oxygen (cu.ft.)	Acetylene (cu.ft.)
1/8	0.0380-0.0400	20-30	0.37-0.45	0.06-0.07
1/4	0.0380-0.0595	16-26	0.63-0.72	0.08-0.11
3/8	0.0380-0.0595	15-24	0.80-0.96	0.10-0.13
1/2	0.0465-0.0595	12-22	1.10-1.14	0.12-0.17
3/4	0.0465-0.0595	12-20	1.43-1.95	0.15-0.20
1	0.0465-0.0595	9-18	1.78-2.89	0.18-0.29
2	0.0670-0.0810	6-13	3.55-6.16	0.31-0.53
3	0.0670-0.0810	4-10	5.80-12.00	0.46-0.95
4	0.0810-0.0860	4-8	9.70-14.64	0.65-1.05
5	0.0810-0.0860	3-5-6-4	13.66-19.83	0.91-1.37
6	0.0980-0.0995	3-0-5-4	21.00-26.70	1.19-1.80
8	0.0980-0.0995	2-6-4-2	29.30-38.84	1.83-2.42
10	0.0980-0.0995	1-9-3-2	46.90-64.20	2.57-3.84
12	0.0980-0.1200	1-4-2-6	67.70-103.00	3.98-6.05

\* Lower speeds for inexperienced operators, short cuts, and dirty steel.

## 6.5 - 6.5.1

### 6.5 Machinability<sup>1</sup>

#### 6.5.1 General

The stainless steels are of three general types, namely, the nonhardenable chromium nickel austenitic grades, the hardenable chromium martensitic grades, and the nonhardenable chromium ferritic grades. These grades can be classified into eight groups with regard to machinability as follows:

1. Nonhardenable chromium nickel austenitic grades
  - a. Types 302, 304, 321, 347, 309, 310, etc.
  - b. Free machining grade, Type 303
  - c. Chromium, Nickel, Manganese, Types 201, 202
2. Hardenable chromium martensitic grades
  - a. Hardenable, low carbon - Types 403 and 410
  - b. Hardenable, free machining - Type 416
  - c. Hardenable, nickel bearing - Types 414 and 431
  - d. Hardenable, high carbon - Types 420 and 440
3. Nonhardenable chromium ferritic grades
  - a. Types 430, 442, and 446

In general, the practice of using oversize motors on all equipment is recommended, as they can take a heavy cut without fear of chatter and resultant hard spots. The availability of free machining stainless steel in both straight chromium and chromium nickel grades simplifies many machining applications. The addition of sulfur (or selenium) improves the machinability, but is slightly detrimental to corrosion resistance. These grades are specified where considerable machining is involved and where service conditions can be satisfied.

Proper selection of the cutting tool may be the deciding factor in the successful machining of the stainless steels.

---

<sup>1</sup> This section was adapted from the Crucible Steel Company of America Data Sheet "Crucible Stainless Steels, Machinability Data", Issue #5, December 1961.

High speed steel tools are adaptable to most form tool operations. The use of a cast nonferrous cobalt-chromium-tungsten alloy for continuous or interrupted turning will allow a higher rate of metal removal due to increased speeds. Tungsten carbide is recommended on many continuous cutting applications requiring a high finish. A compromise must be made between high cutting speeds and tool toughness to meet such applications as tapping and threading. The type of equipment, design of tool, special tool grinds, and the respective preferences of the men concerned will determine the final tool type selection.

#### 6.5.2 Machining the Nonhardenable (Austenitic) Chromium Nickel Grades and Chromium, Nickel, Manganese Grades

These grades are characterized by their work hardening properties and, for that reason, the feed used should be as heavy as possible within the limits of the machine and tool material. In this way, a high rate of metal removal may be obtained by using heavy feeds with relatively low surface speeds. The work and tools should be rigidly supported to prevent or minimize chatter and precautions should be taken to prevent the tool from riding on or glazing the work. The addition of sulfur (or selenium) in the free-machining grades lends freer cutting properties and produces a much crisper and more easily broken chip.

Turning tools, whether high speed steel, cast nonferrous cobalt-chromium-tungsten alloy, or tungsten carbide should be ground with a heavy side rake of 10-20° to allow for maximum freedom of cut. The top surface of the tool should be finished on a fine wheel or hand stoned in order to reduce the cutting pressure and galling. The tendency for galling is considerably less with the free-machining grades. A chip groove is usually necessary (except with the free-machining grades) in order to facilitate proper chip disposal as well as for an added safety precaution, since otherwise it may be extremely difficult to break the chip. Drills should have their normal point of 118° changed to 130° when drilling these steels. A rigid set-up is required and it is sometimes necessary to grind a chip breaker on the drill. The use of a 10-15° back hook on threading tools will ease cutting pressure and improve the thread surface. In threading, the use of a sulfurized cutting oil is recommended.

It is essential that the tools used in the machining of these stainless grades be kept sharp. A dull tool will tend to harden the surface by means of a rubbing action.

## 6.5.2 - 6.5.3

Complete breakdown or failure of the tool will invariably create a hard spot which might prove difficult to remove.

Single point tools operating on a cam are usually recommended for the development of a shape. Form tool operation is possible and is regular practice. It may present some difficulties under normal operating conditions, however, because of the necessity to use light feeds. The free-machining stainless grades are preferred for automatic screw machine operations as light feeds may be taken without great difficulty, these grades being more suitable for form tool operations.

For certain applications, notably threading and automatic screw machine operations, certain advantages can be obtained by using bars which have been moderately cold drawn.

For details of cutting speed and feed, see Table 1.

### 6.5.3 Machining the Hardenable (Martensitic) Chromium Stainless Grades

Machining of the hardenable chromium grades is characterized by the tendency of the chip to gall or build up on the cutting edges and radii of the tool. This results in high tool pressures, high temperatures on the cutting point of the tool, and the tearing of the machined finish of the work. The addition of sulfur (or selenium) to the free-machining grades lends freer cutting properties and minimizes the tendency of the steel to form a built-up edge on the tool. The low carbon grades and the high carbon grades produce chips that are brittle and stringy. The chips produced by the free-machining grades are short and brittle, resulting in relatively easy chip control. The nickel-bearing grades form chips which are stringy, but are tough and difficult to break.

Turning tools, whether high speed steel, cast nonferrous cobalt-chromium-tungsten alloy (see Par. 6.5.2), or tungsten carbide, should be ground with a moderately heavy side rake of 8-15° to allow for freedom of cut. A bright top surface, achieved by finish grinding on a fine wheel or by hand stoning, will aid in preventing chip build-up. In drilling, the normal drill point of 118° should be changed to 130°, and a chip breaker may be necessary to facilitate the curling of the chip. Threading tools should have a back hook of 10-15° to ease the cutting pressure and improve the thread surface. The use of a sulfurized cutting oil is recommended on threading operations.

For the majority of applications, particularly automatic screw machine and tapping operations, bars of the low

carbon and free-machining grades which have been heat treated to 200 to 240 BHN or annealed and cold drawn, are preferred to material in the fully annealed condition. The additional hardness and toughness obtained either by heat treatment or cold drawing reduces the tendency of the chip to build up on the cutting point, thus allowing a better machine finish. Although the nickel bearing steels are heat treatable, they are usually machined in the annealed and cold drawn condition. Because of the relatively high hardness of even the fully annealed material, it will seem more difficult to machine than the other hardenable chromium grades. The high carbon grades are best machined in the fully annealed condition. Because of the abrasive action of the large amounts of chromium carbide, it is necessary that they be machined at slower speeds than the other stainless chromium grades.

For details of cutting speed and feed, see Table 2.

#### 6.5.4 Machining the Nonhardenable Chromium Ferritic Stainless Grades

As in the case of the hardenable chromium grades, the machining of the nonhardenable high chromium stainless steels is characterized by the tendency of the chip to gall or build up on the cutting edges or radii of the tool. This results in high tool pressures, high temperatures on the cutting point of the tool, and the tearing of the machined finish of the work. The chips produced are brittle and stringy.

For instructions on turning tools, drills, and threading tools, refer to instructions given in Par. 6.5.3 for the hardenable chromium stainless steels.

For the majority of applications, particularly automatic screw machine and tapping operations, bars which have been annealed and cold drawn to 200 to 240 BHN are preferable to material in the fully annealed condition. The additional hardness obtained by cold drawing reduces the tendency of the material to build up on the cutting point of the tool, thus allowing a better machine finish.

For details of speed and feed, see Table 1.

MACHINABILITY DATA

OPERATION	TOOLING					
	HIGH SPEED STEEL			TUNGSTEN CARBIDE		
	Cast Non-Ferrous Cobalt-Chromium-Tungsten Alloy					
	Speed, SFM	Feed, Inch	Speed, SFM	Feed, Inch	Speed, SFM	Feed, Inch
	Types 302, 304, 304L, 309, 310, 315, 321, 347, etc.					
Rough Turning	20-40	0.030-0.060	40-70	0.030-0.060	150-200	0.010-0.030
Finish Turning	50-80	0.010-0.020	90-120	0.010-0.020	150-300	0.010-0.020
Drilling	20-40	0.002-0.005				
Reaming	20-60	0.003-0.008	40-80	0.005-0.008	150-250	0.003-0.008
Threading	10-20					
Milling	40-60	0.0005-0.0015				
	Type 303					
Rough Turning	25-50	0.030-0.060	50-90	0.030-0.060	195-260	0.015-0.030
Finish Turning	65-105	0.010-0.020	115-155	0.010-0.020	195-390	0.010-0.020
Drilling	25-50	0.002-0.005				
Reaming	25-80	0.003-0.008	50-105	0.005-0.008	195-325	0.003-0.008
Threading	15-25					
Milling	50-80	0.0005-0.0015				
	Types 430, 442, 446					
Rough Turning	20-45	0.030-0.060	45-75	0.030-0.060	165-220	0.015-0.030
Finish Turning	55-90	0.010-0.020	100-130	0.010-0.020	165-330	0.010-0.020
Drilling	20-45	0.002-0.005				
Reaming	20-65	0.003-0.008	45-90	0.005-0.008	165-275	0.003-0.008
Threading	10-25					
Milling	45-65	0.0005-0.0015				

OPERATION	TOOLING			
	HIGH SPEED STEEL		TUNGSTEN CARBIDE	
	Speed, SFM	Feed, Inch	Speed, SFM	Feed, Inch
	Cast Non-Ferrous Cobalt-Chromium-Tungsten Alloy			
	Speed, SFM		Speed, SFM	
	Feed, Inch		Feed, Inch	
	Types 403 and 410			
Rough Turning	20-45	0.030-0.060	45-80	0.030-0.060
Finish Turning	55-90	0.010-0.020	100-130	0.010-0.020
Drilling	20-45	0.002-0.005	45-90	0.005-0.008
Reaming	25-65	0.003-0.008		165-275
Threading	10-25			165-275
Millling	45-65	0.0005-0.0015		0.003-0.008
	Type 416			
Rough Turning	30-60	0.030-0.060	60-105	0.030-0.060
Finish Turning	75-120	0.010-0.020	135-180	0.010-0.020
Drilling	30-60	0.002-0.005	60-120	0.005-0.008
Reaming	30-60	0.003-0.008		225-375
Threading	15-30			225-375
Millling	60-90	0.0005-0.0015		0.003-0.008
	Types 414 and 431			
Rough Turning	20-40	0.030-0.060	40-70	0.030-0.060
Finish Turning	50-80	0.010-0.020	90-120	0.010-0.020
Drilling	20-40	0.002-0.005	40-80	0.005-0.008
Reaming	20-60	0.003-0.008		150-250
Threading	10-20			150-250
Millling	40-60	0.0005-0.0015		0.003-0.008
	Types 420 and 440			
Rough Turning	15-35	0.030-0.060	35-65	0.030-0.060
Finish Turning	45-70	0.010-0.020	80-110	0.010-0.020
Drilling	15-35	0.002-0.005	35-70	0.005-0.008
Reaming	15-35	0.003-0.008		135-225
Threading	10-15			135-225
Millling	35-55	0.0005-0.0015		0.003-0.008

6.6 - 6.6.3.1

## 6.6 A.S.M.E. CODE FABRICATION INFORMATION

### 6.6.1 General

This section contains selected items from Parts UHA and UW of Section VIII of the A.S.M.E. Boiler and Pressure Vessel Code, 1962 Edition, which pertain to the design, fabrication, and inspection of stainless steel unfired pressure vessels. The applicable paragraphs of the A.S.M.E. Code are listed in parentheses behind the paragraph titles of this section.

### 6.6.2 Conditions of Service (UHA-6)

Specific chemical compositions, heat-treatment procedures, fabrication requirements, and supplementary tests may be required to assure that the vessel will be in its most favorable condition for the intended service. This is particularly true for vessels subject to severe corrosion. These rules do not indicate the selection of an alloy suitable for the intended service or the amount of the corrosion allowance to be provided.

It is recommended that users assure themselves by appropriate tests, or otherwise, that the high alloy steel selected and its heat-treatment during fabrication will be suitable for the intended service both with respect to corrosion resistance and to retention of satisfactory mechanical properties during the desired service life.

### 6.6.3 Materials

#### 6.6.3.1 General (UHA-11)

- a. All materials subject to stress due to pressure shall conform to one of the specifications given in Section II of the Code and shall be limited to those listed in Table UHA-23 (See Tables 1 through 4 of this section) except as provided otherwise in (b) and (c) and in Pars. UG-10 and UG-11. (Pars. UG-10 and UG-11 apply respectively to "Materials Not Fully Identified" and "Miscellaneous Pressure Parts". These regulations apply to all types of materials. The specifications in Section II of the Code, referred to above, are identical to the A.S.T.M. specifications bearing the same numbers. For example, A.S.T.M. A201 is the same as A.S.M.E. SA201).
- b. When the desired type of approved stainless steel is lacking in the specification covering the applicable form (tubing, casting, etc.), the material may be furnished to the general requirements of an approved specification with the chemical and mechanical properties conforming to those shown in another approved specification for the desired grade.

- c. Columbium or columbium plus tantalum may be added to Types 309, 310 and 316 material in an amount not less than nine times the carbon content and not greater than 1.0 per cent. These materials are designated Types 309Cb, 310Cb, and 316Cb, respectively, in these rules. The maximum allowable stress values for materials with columbium or columbium plus tantalum added shall be the same as given in Tables 1 through 4 (UHA-23) for Types 309, 310 and 316 respectively. (Author's Note: Fully austenitic stainless steels when stabilized with columbium or columbium plus tantalum are highly susceptible to weld cracking. See Par. 6.1.1 "Weldability".)
- d. The specifications listed in Tables 1 through 4 (UHA-23) do not use a uniform system for designating the grade number of materials that have approximately the same range of chemical composition. To supply such a uniform system of reference, Table UHA-23 (Tables 1 through 4) give opposite each grade the AISI type number which has approximately the same grade of chemical composition. These type numbers are used in the rules of Part UHA whenever reference is made to materials of approximately the same chemical composition that are furnished under more than one approved specification or in more than one product-form.

#### 6.6.3.2 Castings (UHA-8)

- a. Approved specifications for castings of high alloy steel are given in Tables 3 and 4 (UHA-23) together with a tabulation of allowable stress values at different temperatures. These stress values are to be multiplied by the casting quality factors of Par. UG-24 (See Par. 6.6.8). Castings that are to be welded shall be of weldable grade.
- c. Cast high alloy steel flanges and fittings complying with ASA B16.5-1961 shall be used within the ratings assigned in these standards.

#### 6.6.4 Design

The rules to be followed in the design of high alloy steel vessels are, in general, the same as for carbon and low alloy steel vessels. These rules are not included in this section.

##### 6.6.4.1 Minimum Thickness of Plate (UHA-20(b))

The minimum thickness after forming of any plate subject to pressure shall be  $3/32$  inch, except that for high alloy materials in non-corrosive service the minimum thickness shall be  $1/16$  inch.

#### 6.6.5 Fabrication

##### 6.6.5.1 General (UHA-40)

The rules in the following paragraphs apply specifically to the fabrication of unfired pressure vessels and vessel parts that

#### 6.6.5.1 - 6.6.6.1

are constructed of high-alloy steel and shall be used in conjunction with the general requirements for "Fabrication" in Subsection A, and with the specific requirements for "Fabrication" in Subsection B that pertain to the method of fabrication used. (These general requirements are the same as for carbon and low-alloy steel vessels and will not be included in this section.)

#### 6.6.5.2 Marking and Mill Test Reports (UHA-41)

- a. The specification number, grade or type number, test identification number, and the name of the manufacturer shall be legibly marked on each plate not less than 12 inches from the edges. Die stamping may be harmful for some conditions of service.
- b. The plate manufacturer shall describe on mill-test reports any heat-treatments carried out by him.

#### 6.6.5.3 Weld-Metal Composition (UHA-42)

Welds that are exposed to the corrosive action of the contents of the vessel should have a resistance to corrosion that is not substantially less than that of the base metal. The use of filler metal that will deposit weld metal with practically the same composition as the metal joined is recommended. When the manufacturer is of the opinion that a physically better joint can be made by departure from these limits, filler metal of a different composition may be used provided the strength of the weld metal at the operating temperature is not appreciably less than that of the high-alloy material to be welded, and the user is satisfied that its resistance to corrosion is satisfactory for the intended service. The columbium content of the weld metal shall not exceed 1.00 per cent.

#### 6.6.6 Heat Treatment

##### 6.6.6.1 Thermal Stress-Relieving (UHA-32)

- a. Heat-treatment, including stress relief, of welded vessels constructed of austenitic chromium-nickel stainless steels is neither required nor prohibited. The need for and the details of heat-treatment depend on the type of alloy steel and service conditions.
- b. Ferritic steel parts of austenitic chromium-nickel stainless steel vessels shall not be subjected to the solution heat-treatment described in UHA-105(b). (See Par. 6.6.6.2).
- c. All welded vessels constructed of ferritic chromium stainless steels, except as permitted in (d) below, shall be stress-relieved in all thicknesses.

- d. When Type 405 and Type 410S in plate thicknesses not exceeding  $3/8$  in. are welded with austenitic electrodes, stress-relieving or other heat-treatment is neither mandatory nor prohibited. For heavier thickness stress-relieving is required, except that for thicknesses over  $3/8$  in. and up to and including  $1-1/2$  in. stress-relieving need not be performed provided the joints are completely radiographed, and provided a preheat of  $450^{\circ}\text{F.}$  minimum is maintained during welding.
- e. Thermal stress-relieving of the ferritic stainless steels shall be performed as prescribed in Par. UW-40 (the paragraph that gives general rules covering the stress relieving of carbon and low alloy steel vessels), except that the holding temperature shall be between  $1350^{\circ}$  and  $1450^{\circ}\text{F.}$  with a maximum cooling rate of  $100^{\circ}\text{F.}$  per hour in the range above  $1100^{\circ}\text{F.}$ , after which cooling in still air is permitted.

#### 6.6.6.2 Carbide Solution Annealing (UHA-105)

Where maximum corrosion resistance is required, it is advisable to heat-treat in such a fashion as to place all chromium carbides in solution. For such service it is recommended that the following procedure be followed:

Hold the vessel within the prescribed temperature range for not less than one hour per inch of thickness. Quench all parts of the vessel uniformly and as rapidly as possible. Material not stabilized with columbium or titanium should be cooled through the range from  $1700^{\circ}\text{F.}$  to  $1000^{\circ}\text{F.}$  in not more than 3 minutes. The rapid cooling should be continued to below  $800^{\circ}\text{F.}$  Slower cooling rates may be just as satisfactory for some compositions of the material and conditions of service.

Recommended temperature ranges for carbide solution annealing of the various austenitic stainless steel grades are as follows:

<u>A.I.S.I. Type Number</u>	<u>Temperature Range</u>
301, 302, 304, 308, 309, 310	$1850^{\circ}$ - $2000^{\circ}\text{F.}$
321, 347	$1850^{\circ}$ - $2000^{\circ}\text{F.}$
316	$1850^{\circ}$ - $2050^{\circ}\text{F.}$
309Cb, 310Cb, 316Cb	$1850^{\circ}$ - $1950^{\circ}\text{F.}$

## 6.6.7 - 6.6.7.2

### 6.6.7 Inspection and Tests

#### 6.6.7.1 General (UHA-50)

The rules in the following paragraphs apply specifically to the inspection and testing of unfired pressure vessels and vessel parts that are constructed of high-alloy steel and shall be used in conjunction with the general requirements for "Inspection and Tests" in Subsection A, and with the specific requirements for "Fabrication" in Subsection B that pertain to the method of fabrication used.

#### 6.6.7.2 Impact Tests (UHA-51)

Impact tests as prescribed in Par. UG-84 (General Methods and Requirements) shall be made for the following combinations of materials and operating temperatures.

- a. For Types 304, 304L and 347 at operating temperatures below  $-425^{\circ}\text{F}$ . and all other materials below  $-325^{\circ}\text{F}$ .
- b. For the following materials operating at a metal temperature below  $-20^{\circ}\text{F}$ . except when the minimum thickness is the greater of those determined under the most severe condition of coincident pressure (external or internal) and temperature in accordance with UG-21 for temperatures (a)  $-20^{\circ}\text{F}$ . and above, and (b) below  $-20^{\circ}\text{F}$ . in which case the coincident pressure (internal if above atmospheric and external if below atmospheric) shall be multiplied by two and one half:
  1. Ferritic chromium stainless steels.
  2. Austenitic chromium-nickel stainless steels with carbon in excess of 0.10%.
  3. Austenitic chromium-nickel stainless steels that have a nickel or a chromium content in excess of the AISI standard analysis range of the specified type number and physical form.
  4. Material in casting form.
  5. Material in the form of deposited weld metal.
- c. For the following materials at all values of operating temperature: Type 309, 310, 316, 309Cb, 310Cb, or 316Cb material that is stress-relieved at temperatures below  $1650^{\circ}\text{F}$ . The tests shall include the weld metal and shall be made at room temperature, or at operating temperature if lower. (Par. UG-21 states that vessels covered by this section of the Code shall be designed for at least the most severe condition of coincident pressure and temperature expected in normal operation. For this condition, the maximum difference in

pressure between the inside and outside of a vessel, or between any two chambers of a combination unit, shall be considered).

#### 6.6.7.3 Welded Test Plates (UHA-52)

- a. For welded vessels constructed of Type 405 material which are not stress-relieved, welded test plates shall be made to include material from each melt of plate steel used in the vessel. Plates from two different melts may be welded together and be represented by a single test plate.
- b. From each welded test plate there shall be taken two face-bend test specimens.

#### 6.6.7.4 Penetrant Oil and Powder Examination (UHA-34)

All austenitic chromium-nickel alloy steel welds, both butt and fillet, in vessels whose shell thickness exceeds 3/4 in. shall be examined for the detection of cracks by the liquid penetrant method. This examination shall be made following heat-treatment if heat-treatment is performed. All cracks shall be eliminated.

#### 6.6.7.5 Radiographic Examination (UHA-33)

- a. The requirements for radiographing prescribed in Par. UW-11, UW-51, and UW-52 shall apply to high-alloy vessels, except as provided in (b).
- b. Butt-welded joints in vessels constructed of materials conforming to Type 405 welded with straight chromium electrodes, and to Types 410 and 430 welded with any electrode, shall be radiographed in all thicknesses. Butt-welded joints in vessels constructed of Type 405 material or of Type 410 with carbon content not to exceed 0.08 per cent, welded with electrodes that produce an austenitic chromium-nickel weld deposit or a non-air-hardening nickel chromium iron deposit shall be radiographed when the plate-thickness at the welded joint exceeds 1-1/2 in. The final radiographs of all straight chromium ferritic welds including major repairs to these welds, shall be made after stress relieving has been performed.
- c. Butt-welded joints in vessels constructed of austenitic chromium-nickel stainless steels which are radiographed because of the thickness requirements of Par. UW-11, (joints in plates or vessel walls in which the thickness at the welded joint exceeds 1-1/2 in.) or for lesser thicknesses where the joint efficiency reflects the credit for radiographic examination, shall be radiographed following post-heating if such is performed.

6.6.7.6

6.6.7.6 Radiographic Inspection Techniques and Requirements (UW-51)

- a. All welds which require complete radiographic examination shall be examined throughout their entire length by the x-ray or gamma ray method of radiography.
- b. All butt-welded joints to be radiographed shall be prepared as follows: The weld ripples or weld surface irregularities, on both the inside and outside, shall be removed by any suitable mechanical process to a degree such that the resulting radiographic contrast due to any remaining irregularities cannot mask or be confused with that of any objectionable defect. Also the weld surface shall merge smoothly into the plate surface. The finished surface of the reinforcement may be flush with the plate or have a reasonably uniform crown not to exceed the following thickness:

<u>Plate Thickness, In.</u>	<u>Thickness of Reinforcement, In.</u>
Up to 1/2, incl.	1/16
Over 1/2 to 1	3/32
Over 1 to 2	1/8
Over 2	5/32

- c. Single welded butt joints made by using a backing strip which is left in place may be radiographed provided the backing strip does not interfere with the interpretation of the resultant radiographs.
- d. The weld shall be radiographed with a technique which will indicate the size of defects having a thickness equal to and greater than 2% of the thickness of the base metal.
- e. As a check on the radiographic technique employed, thickness gages or penetrameters shall be used in the following manner to determine whether the requirements of (d) are being met:
  - 1. The penetrameters shall be placed on the side nearest the radiation source except when complying with the provisions of (g).
  - 2. At least one penetrameter shall be used for each exposure, to be placed at one end of the exposed length, parallel and adjacent to the weld seam, with the small holes at the outer end. When there is any difference between the angularity of the radiation at the two ends, the penetrameter shall be placed at the end of maximum angularity.
  - 3. The material of the penetrameter shall be substantially the same as that of the plate under examination.

4. The thickness of the penetrameter shall be not more than 2% of the thickness of the plate being radiographed, but for thin plates need not be less than 0.005 in. When the penetrameter is placed adjacent to the weld seam and the weld reinforcement and/or backing strip is not removed, a shim of the same alloy as the backing strip shall be placed under the penetrameter such that the total thickness being radiographed under the penetrameter is the same as the total thickness through the weld, including the backing strip when used and not removed.
- f. The film during exposure shall be as close to the surface of the weld as practicable. If possible, this distance shall not be greater than one inch. In this paragraph "S" is defined as the distance from the radiation side of the weld to the source of radiation and "f" is defined as the distance from the radiation side of the weld to the film. When the ratio "S/f" is less than 7/1, the manufacturer shall satisfy the inspector that the technique employed doing the work is known to be adequate. In all cases when the ratio S/f is less than 7 to 1, the ratio shall be clearly indicated directly on each film or by attaching the information thereto.
- g. Penetrameters may be placed on the film side of the joint provided the manufacturer can satisfy the inspector that the technique employed in doing the work is known to be adequate.
- h. When the source of gamma rays is placed on the axis of the joint and the complete circumference is radiographed with a single exposure, four uniformly spaced penetrameters shall be employed.
- i. All radiographs shall be free from excessive mechanical processing defects that would interfere with proper interpretation of the radiograph.
- j. Identification markers, the images of which will appear on the film, shall be placed adjacent to the weld, and their locations shall be accurately and permanently marked on the outside surface near the weld, so that a defect appearing on the radiograph may be accurately located.
- k. The job number, the vessel, the seam, and the manufacturer's identification symbol or name shall be plainly indicated on each film.
- l. The radiographs shall be submitted to the inspector with such information regarding the radiographic technique as he may request.

## 6.6.7.6 - 6.6.8.2

- m. Sections of weld that are shown by radiography to have any of the following types of imperfections shall be judged unacceptable and shall be repaired:
1. Any type of crack or zone of incomplete fusion or penetration.
  2. Any elongated slag inclusion which has a length greater than:  
1/4 in. for T up to 3/4 in.  
1/3 T for T from 3/4 in. to 2-1/4 in.  
3/4 T for T over 2-1/4 in.

where T is the thickness of the thinner plate being welded.

3. Any group of slag inclusions in line that have an aggregate length greater than T in a length of 12T, except when the distance between the successive imperfections exceeds 6L where L is the length of the longest imperfection in the group.
4. Porosity in excess of that shown as acceptable by the standards given in Figures 1 through 6.
5. A complete set of radiographs for each job shall be retained by the manufacturer and kept on file for a period of at least 5 years.

## 6.6.8 Castings (UG-24)

### 6.6.8.1 Quality Factors

A casting quality factor as specified below shall be applied to the allowable stress values (Tables 1 through 4). Information on inspection and testing of castings is given in Exhibit I.

- a. A factor not to exceed 80% shall be applied when a casting is inspected only in accordance with the minimum requirements of the specification of the material.
- b. For carbon, low alloy, or high alloy steels, a factor not to exceed 100% may be applied if in addition to the minimum requirements of the specification the inspection and testing requirements of Exhibit I are met.

### 6.6.8.2 Defects

Serious defects shall be the basis for rejection of the casting. The inspector shall have the right to demand a similar inspection of any number of additional castings from the same heat until acceptable castings are consistently produced where a 90 or 100% quality factor is used. Where defects not impairing

### 6.6.8.2 - 6.6.8.3

the strength of the casting have been repaired by welding, the completed repair shall be subject to reinspection, and to obtain a 90 or 100% factor, the repaired casting shall be stress relieved.

#### 6.6.8.3 Identification and Marking

Castings to which a quality factor of 90 or 100% is to be applied shall be marked with the manufacturer's and materials identification marking and in addition the quality factor shall be clearly stamped on the casting. Test reports or certificates furnished by the manufacturer shall certify that the castings conform to the requirements of the Code.

Par. 6.6 Table 1

TABLE UHA-23 MAXIMUM ALLOWABLE STRESS VALUES IN TENSION FOR HIGH-ALLOY STEEL, IN POUNDS PER SQUARE INCH

Material and Specification Number	Grade	Type	Nominal Composition	Spec Min Tensile	Notes	For Metal Temperatures Not Exceeding Deg F									
						-20 to 100	200	300	400	500	600	650	700	750	
<b>PLATE STEELS</b>															
SA-240	..	302	18 Cr-8 Ni	75000	(1)(10)	18750	17000	16000	15450	15100	14900	14850	14350	14700	
SA-240	..	302	18 Cr-8 Ni	75000	(10)	18750	16650	15000	13650	12500	11600	11200	10800	10400	
SA-240	..	304	18 Cr-8 Ni	75000	(1)(10)	18750	17000	16000	15450	15100	14900	14850	14800	14700	
SA-240	..	304	18 Cr-8 Ni	75000	(10)	18750	16650	15000	13650	12500	11600	11200	10800	10400	
SA-240	..	304L	18 Cr-8 Ni	70000	(1)	17500	17000	16000	15000	14000	13000	12500	12000	11500	
SA-240	..	304L	18 Cr-8 Ni	70000	..	17500	15300	13100	11000	9700	9000	8750	8500	8300	
SA-240	..	309S	23 Cr-13 Ni	75000	(10)	18750	18750	17300	16700	16600	16500	16450	16400	16200	
SA-240	..	310S	25 Cr-20 Ni	75000	(2)(10)	18750	18750	18500	18200	17700	17200	16900	16600	16250	
SA-240	..	310S	25 Cr-20 Ni	75000	(3)(10)	18750	18750	18500	18200	17700	17200	16900	16600	16250	
SA-240	..	316	18 Cr-10 Ni-2 Mo	75000	(10)	18750	18750	17900	17500	17200	17100	17050	17000	16900	
SA-240	..	316L	18 Cr-10 Ni-2 Mo	70000	(1)	17500	17500	15800	14750	14000	13600	13450	13250	13000	
SA-240	..	316L	18 Cr-10 Ni-2 Mo	70000	..	17500	16250	14500	12000	11000	10150	9800	9450	9100	
SA-240	..	317	19 Cr-13 Ni-3 Mo	75000	(10)	18750	18750	17900	17500	17200	17100	17050	17000	16900	
SA-240	..	321	18 Cr-10 Ni-Ti	75000	(10)	18750	18750	17000	15800	15200	14900	14850	14800	14700	
SA-240	..	347	18 Cr-10 Ni-Cb	75000	(10)	18750	18750	17000	15800	15200	14900	14850	14800	14700	
SA-240	..	348	18 Cr-10 Ni-Cb-Ti	75000	(10)	18750	18750	17000	15800	15200	14900	14850	14800	14700	
SA-240	..	405	12 Cr-Al	60000	..	15000	15000	14700	14400	13950	13400	13000	12450	11800	
SA-240	..	410	13 Cr	65000	..	16250	15600	15100	14600	14150	13850	13700	13400	13100	
SA-240	..	410S	13 Cr	60000	..	15000	14450	14000	13500	13100	12850	12700	12500	12250	
SA-240	..	430A	15 Cr	65000	..	16250	16250	15200	14500	14000	13550	13250	12900	12500	
SA-240	..	430B	17 Cr	65000	..	16250	16250	15200	14500	14000	13550	13250	12900	12500	
<b>PIPES &amp; TUBES</b>															
<b>Seamless</b>															
SA-213	TP304	...	18 Cr-8 Ni	75000	(1)(10)	18750	17000	16000	15450	15100	14900	14850	14800	14700	
SA-213	TP304	...	18 Cr-8 Ni	75000	(10)	18750	16650	15000	13650	12500	11600	11200	10800	10400	
SA-213	TP304L	...	18 Cr-8 Ni	70000	(1)	17500	17000	16000	15000	14000	13000	12500	12000	11500	
SA-213	TP304L	...	18 Cr-8 Ni	70000	..	17500	15300	13100	11000	9700	9000	8750	8500	8300	
SA-213	TP310	...	25 Cr-20 Ni	75000	(2)(10)	18750	18750	18500	18200	17700	17200	16900	16600	16250	
SA-213	TP310	...	25 Cr-20 Ni	75000	(3)(10)	18750	18750	18500	18200	17700	17200	16900	16600	16250	
SA-213	TP316	...	16 Cr-13 Ni-3 Mo	75000	(10)	18750	18750	17900	17500	17200	17100	17050	17000	16900	
SA-213	TP316L	...	18 Cr-12 Ni-2 Mo	70000	(1)	17500	17500	15800	14750	14000	13600	13450	13250	13000	
SA-213	TP316L	...	18 Cr-12 Ni-2 Mo	70000	..	17500	16250	14500	12000	11000	10150	9800	9450	9100	
SA-213	TP321	...	18 Cr-10 Ni-Ti	75000	(10)	18750	18750	17000	15800	15200	14900	14850	14800	14700	
SA-213	TP321H	...	18 Cr-10 Ni-Ti	75000	(10)	18750	18750	17000	15800	15200	14900	14850	14800	14700	
SA-213	TP347	...	18 Cr-10 Ni-Cb	75000	(10)	18750	18750	17000	15800	15200	14900	14850	14800	14700	
SA-213	TP348	...	18 Cr-10 Ni-Cb	75000	(10)	18750	18750	17000	15800	15200	14900	14850	14800	14700	
SA-268	TP405	...	12 Cr-Al	60000	..	15000	15000	14700	14400	13950	13400	13000	12450	11800	
SA-268	TP410	...	13 Cr	60000	..	15000	14450	14000	13500	13100	12850	12700	12500	12250	
SA-268	TP430	...	16 Cr	60000	(9)	15000	15000	14100	13400	13000	12500	12200	11850	11500	
SA-268	TP446	...	27 Cr	70000	..	17500	17500	17500	17500	17500	17500	17500	..	..	
SA-312	TP304	...	18 Cr-8 Ni	75000	(1)(10)	18750	17000	16000	15450	15100	14900	14850	14800	14700	
SA-312	TP304	...	18 Cr-8 Ni	75000	(10)	18750	16650	15000	13650	12500	11600	11200	10800	10400	
SA-312	TP304L	...	18 Cr-8 Ni	70000	(1)	17500	17000	16000	15000	14000	13000	12500	12000	11500	
SA-312	TP304L	...	18 Cr-8 Ni	70000	..	17500	15300	13100	11000	9700	9000	8750	8500	8300	
SA-312	TP309	...	25 Cr-12 Ni	75000	(10)	18750	18750	17300	16700	16600	16500	16450	16400	16200	
SA-312	TP310	...	25 Cr-20 Ni	75000	(2)(10)	18750	18750	18500	18200	17700	17200	16900	16600	16250	
SA-312	TP310	...	25 Cr-20 Ni	75000	(3)(10)	18750	18750	18500	18200	17700	17200	16900	16600	16250	
SA-312	TP316L	...	18 Cr-12 Ni-2 Mo	70000	(1)	17500	17500	15800	14750	14000	13600	13450	13250	13000	
SA-312	TP316L	...	18 Cr-12 Ni-2 Mo	70000	..	17500	16250	14500	12000	11000	10150	9800	9450	9100	
SA-312	TP321	...	18 Cr-10 Ni-Ti	75000	(10)	18750	18750	17000	15800	15200	14900	14850	14800	14700	
SA-312	TP347	...	18 Cr-10 Ni-Cb	75000	(10)	18750	18750	17000	15800	15200	14900	14850	14800	14700	
SA-312	TP348	...	18 Cr-10 Ni-Cb	75000	(10)	18750	18750	17000	15800	15200	14900	14850	14800	14700	
SA-312	TP316	...	16 Cr-13 Ni-3 Mo	75000	(10)	18750	18750	17900	17500	17200	17100	17050	17000	16900	
SA-312	TP317	...	18 Cr-13 Ni-4 Mo	75000	(10)	18750	18750	17900	17500	17200	17100	17050	17000	16900	
SA-376	TP304	...	18 Cr-8 Ni	75000	(1)(10)	18750	17000	16000	15450	15100	14900	14850	14800	14700	
SA-376	TP304	...	18 Cr-8 Ni	75000	(10)	18750	16650	15000	13650	12500	11600	11200	10800	10400	
SA-376	TP321	...	18 Cr-10 Ni-Ti	75000	(10)	18750	18750	17000	15800	15200	14900	14850	14800	14700	
SA-376	TP347	...	18 Cr-10 Ni-Cb	75000	(10)	18750	18750	17000	15800	15200	14900	14850	14800	14700	
SA-376	TP348	...	18 Cr-10 Ni-Cb	75000	(10)	18750	18750	17000	15800	15200	14900	14850	14800	14700	
SA-376	TP316	...	16 Cr-13 Ni-3 Mo	75000	(10)	18750	18750	17900	17500	17200	17100	17050	17000	16900	
SA-430	FP304H	...	18 Cr-8 Ni	70000	(7)	17500	15850	14950	14400	14100	13900	13850	13800	13700	
SA-430	FP304H	...	18 Cr-8 Ni	70000	..	17500	15850	14800	13650	12500	11600	11200	10800	10400	
SA-430	FP321H	...	18 Cr-10 Ni-Ti	70000	..	17500	17500	15850	14750	14200	13900	13850	13800	13700	
SA-430	FP347H	...	18 Cr-10 Ni-Cb	70000	..	17500	17500	15850	14750	14200	13900	13850	13800	13700	
SA-430	FP316H	...	18 Cr-10 Ni-3 Mo	70000	..	17500	17500	16700	16350	16050	15950	15900	15850	15800	
<b>Welded</b>															
SA-249	TP304	...	18 Cr-8 Ni	75000	(1)(4)(10)	16000	14450	13600	13150	12800	12700	12650	12600	12500	
SA-249	TP304	...	18 Cr-8 Ni	75000	(4)(10)	16000	14150	12750	11600	10600	9850	9500	9200	8850	
SA-249	TP304L	...	18 Cr-8 Ni	70000	(1)(4)	14900	14500	13600	12750	11900	11050	10600	10200	9800	
SA-249	TP304L	...	18 Cr-8 Ni	70000	(4)	14900	13000	11150	9350	8250	7650	7450	7200	7050	
SA-249	TP309	...	23 Cr-13 Ni	75000	(4)(10)	16000	16000	14750	14200	14100	14050	14000	13950	13800	
SA-249	TP310	...	25 Cr-20 Ni	75000	(2)(4)(10)	16000	16000	15750	15500	15050	14600	14400	14100	13800	
SA-249	TP310	...	25 Cr-20 Ni	75000	(3)(4)(10)	16000	16000	15750	15500	15050	14600	14400	14100	13800	
SA-249	TP316	...	16 Cr-13 Ni-3 Mo	75000	(4)(10)	16000	16000	15200	14900	14600	14550	14500	14450	14350	

Par. 6.6 Table 2

TABLE UHA-23 MAXIMUM ALLOWABLE STRESS VALUES IN TENSION FOR HIGH-ALLOY STEEL, IN POUNDS PER SQUARE INCH (continued)

For Metal Temperatures Not Exceeding Deg F															Material and Specification	
800	850	900	950	1000	1050	1100	1150	1200	1250	1300	1350	1400	1450	1500	Number	Grade
PLATE STEELS																
...	...	...	...	...	...	...	...	...	...	...	...	...	...	...	SA-240	302
...	...	...	...	...	...	...	...	...	...	...	...	...	...	...	SA-240	302
14550	14300	14000	13400	12500	10000	7500	5750	4500	3250	2450	1800	1400	1000	750	SA-240	304
16900	9700	9400	9100	8800	8500	7500	5750	4500	3250	2450	1800	1400	1000	750	SA-240	304
11600	...	...	...	...	...	...	...	...	...	...	...	...	...	...	SA-240	304L
8100	...	...	...	...	...	...	...	...	...	...	...	...	...	...	SA-240	304L
15700	14900	13800	12500	10500	8500	6500	5000	3800	2900	2300	1750	1300	900	750	SA-240	309S
15700	14900	13800	12500	11000	9750	8500	7250	6000	4750	3500	2350	1600	1100	750	SA-240	310S
15700	14900	13800	12500	11000	7100	5000	3600	2500	1450	750	450	350	250	200	SA-240	310S
16750	16500	16000	15100	14000	12200	10400	8500	6800	5300	4000	3000	2350	1850	1500	SA-240	316
12700	12250	...	...	...	...	...	...	...	...	...	...	...	...	...	SA-240	316L
8900	8500	...	...	...	...	...	...	...	...	...	...	...	...	...	SA-240	316L
16750	16500	16000	15100	14000	12200	10400	8500	6800	5300	4000	3000	2350	1850	1500	SA-240	317
14450	14300	14100	13850	13500	13100	12500	8000	5000	3600	2700	2000	1550	1200	1000	SA-240	321
14450	14300	14100	13850	13500	13100	12500	8000	5000	3600	2700	2000	1550	1200	1000	SA-240	347
14550	14300	14100	13850	13500	13100	12500	8000	5000	3600	2700	2000	1550	1200	1000	SA-240	348
11600	10100	9100	8000	4000	...	...	...	...	...	...	...	...	...	...	SA-240	405
12750	12100	11000	8800	6400	4400	2900	1750	1000	...	...	...	...	...	...	SA-240	410
11950	11600	11000	8800	6400	4400	2900	1750	1000	...	...	...	...	...	...	SA-240	410S
12050	11500	10800	9200	6500	4500	3200	2400	1750	...	...	...	...	...	...	SA-240	430A
12050	11500	10800	9200	6500	4500	3200	2400	1750	...	...	...	...	...	...	SA 240	430B
PIPES & TUBES																
Seamless																
14550	14300	14000	13400	12500	10000	7500	5750	4500	3250	2450	1800	1400	1000	750	SA-213	TP304
10900	9700	9400	9100	8800	8500	7500	5750	4500	3250	2450	1800	1400	1000	750	SA-213	TP304
11600	...	...	...	...	...	...	...	...	...	...	...	...	...	...	SA-213	TP304L
8100	...	...	...	...	...	...	...	...	...	...	...	...	...	...	SA-213	TP304L
15700	14900	13800	12500	11000	9750	8500	7250	6000	4750	3500	2350	1600	1100	750	SA-213	TP310
15700	14900	13800	12500	11000	7100	5000	3600	2500	1450	750	450	350	250	200	SA-213	TP310
16750	16500	16000	15100	14000	12200	10400	8500	6800	5300	4000	3000	2350	1850	1500	SA-213	TP316
12700	12250	...	...	...	...	...	...	...	...	...	...	...	...	...	SA-213	TP316L
8900	8500	...	...	...	...	...	...	...	...	...	...	...	...	...	SA-213	TP316L
14550	14300	1400	13850	13500	...	...	...	...	...	...	...	...	...	...	SA-213	TP321
14550	14300	14100	13850	13500	13100	12500	8000	5000	3600	2700	2000	1550	1200	1000	SA-213	TP321H
14550	14300	14100	13850	13500	13100	12500	8000	5000	3600	2700	2000	1550	1200	1000	SA-213	TP347
14550	14300	14100	13850	13500	13100	12500	8000	5000	3600	2700	2000	1550	1200	1000	SA-213	TP348
11000	10100	9100	8000	4000	...	...	...	...	...	...	...	...	...	...	SA 268	TP405
11950	11600	11000	8800	6400	4400	2900	1750	1000	...	...	...	...	...	...	SA-268	TP410
11100	10600	10000	9200	6500	4500	3200	2400	1750	...	...	...	...	...	...	SA-268	TP430
...	...	...	...	...	...	...	...	...	...	...	...	...	...	...	SA-268	TP446
14550	14300	14000	13400	12500	10000	7500	5750	4500	3250	2450	1800	1400	1000	750	SA-312	TP304
10900	9700	9400	9100	8800	8500	7500	5750	4500	3250	2450	1800	1400	1000	750	SA-312	TP304
11600	...	...	...	...	...	...	...	...	...	...	...	...	...	...	SA 312	TP304L
8100	...	...	...	...	...	...	...	...	...	...	...	...	...	...	SA-312	TP304L
15700	14900	13800	12500	10500	8500	6500	5000	3800	2900	2300	1750	1300	900	750	SA-312	TP309
15700	14900	13800	12500	11000	9750	8500	7250	6000	4750	3500	2350	1600	1100	750	SA-312	TP310
15700	14900	13800	12500	11000	7100	5000	3600	2500	1450	750	450	350	250	200	SA-312	TP310
12700	12250	...	...	...	...	...	...	...	...	...	...	...	...	...	SA-312	TP316L
8900	8500	...	...	...	...	...	...	...	...	...	...	...	...	...	SA-312	TP316L
14550	14300	14100	13850	13500	13100	12500	8000	5000	3600	2700	2000	1550	1200	1000	SA-312	TP321
14550	14300	14100	13850	13500	13100	12500	8000	5000	3600	2700	2000	1550	1200	1000	SA-312	TP347
14550	14300	14100	13850	13500	13100	12500	8000	5000	3600	2700	2000	1550	1200	1000	SA-312	TP348
16750	16500	16000	15100	14000	12200	10400	8500	6800	5300	4000	3000	2350	1850	1500	SA-312	TP316
16750	16500	16000	15100	14000	12200	10400	8500	6800	5300	4000	3000	2350	1850	1500	SA-312	TP317
14550	14300	14000	13400	12500	10000	7500	5750	4500	3250	2450	1800	1400	1000	750	SA-376	TP304
10900	9700	9400	9100	8800	8500	7500	5750	4500	3250	2450	1800	1400	1000	750	SA-376	TP304
14550	14300	14100	13850	13500	13100	12500	8000	5000	3600	2700	2000	1550	1200	1000	SA-376	TP321
14550	14300	14100	13850	13500	13100	12500	8000	5000	3600	2700	2000	1550	1200	1000	SA-376	TP347
14550	14300	14100	13850	13500	13100	12500	8000	5000	3600	2700	2000	1550	1200	1000	SA-376	TP348
16750	16500	16000	15100	14000	12200	10400	8500	6800	5300	4000	3000	2350	1850	1500	SA-376	TP316
13600	13350	13050	12800	12500	10000	7500	5750	4500	3250	2450	1800	1400	1000	750	SA-430	FP304H
10000	9700	9400	9100	8800	8500	7500	5750	4500	3250	2450	1800	1400	1000	750	SA-430	FP304H
13650	13600	13600	13550	13500	13100	10300	7600	5000	3300	2200	1500	1200	900	750	SA-430	FP321H
13650	13600	13600	13550	13500	13100	10300	7600	5000	3300	2200	1500	1200	900	750	SA-430	FP347H
15650	15400	14950	14500	14000	12200	10400	8500	6800	5300	4000	2700	2000	1500	1000	SA-430	FP316H
Welded																
12400	12150	11900	11400	10600	8500	6400	4900	3800	2750	2100	1550	1200	850	650	SA-249	TP340
8500	8250	8000	7750	7500	7200	6400	4900	3800	2750	2100	1550	1200	850	650	SA-249	TP340
9350	...	...	...	...	...	...	...	...	...	...	...	...	...	...	SA-249	TP304L
6900	...	...	...	...	...	...	...	...	...	...	...	...	...	...	SA-249	TP304L
13350	12700	11700	10600	8900	7200	5500	4250	3250	2450	1950	1500	1100	750	650	SA-249	TP309
13350	12700	11700	10600	9350	8300	7200	6150	5100	4050	3000	2000	1350	950	650	SA-249	TP310
13350	12700	11700	10600	9350	6000	4250	3050	2100	1250	650	400	300	200	150	SA-249	TP310
14250	14000	13600	12800	11900	10400	8850	7200	5800	4500	3400	2550	2000	1550	1300	SA-249	TP316

Par. 6.6 Table 3

TABLE UHA-23 MAXIMUM ALLOWABLE STRESS VALUES IN TENSION FOR HIGH-ALLOY STEEL, IN POUNDS PER SQUARE INCH (continued)

Material and Specification Number	Grade	Type	Nominal Composition	Spec Min Tensile	Notes	For Metal Temperatures Not Exceeding Deg F									
						-20 to 100	200	300	400	500	600	650	700	750	
SA-249	TP316L	...	18 Cr-12 Ni-2 Mo	70000	(1)(4)	14900	14900	13450	12550	11900	11600	11400	11250	11050	
SA-249	TP316L	...	18 Cr-12 Ni-2 Mo	70000	(4)	14900	13800	12300	10200	9350	8650	8350	8050	7750	
SA-249	TP317	...	18 Cr-13 Ni-4 Mo	75000	(4)(10)	16000	16000	15200	14900	14600	14550	14500	14450	14350	
SA-249	TP321	...	18 Cr-10 Ni-Ti	75000	(4)(10)	16000	16000	14450	13400	12900	12700	12650	12600	12500	
SA-249	TP347	...	18 Cr-10 Ni-Cb	75000	(4)(10)	16000	16000	14450	13400	12900	12700	12650	12600	12500	
SA-249	TP348	...	18 Cr-10 Ni-Cb	75000	(4)(10)	16000	16000	14450	13400	12900	12700	12650	12600	12500	
SA-268	TP405	...	12 Cr-Al	60000	(4)	12750	12750	12500	12250	11900	11400	11050	10600	10000	
SA-268	TP410	...	13 Cr	60000	(4)	12750	12300	11900	11500	11150	10900	10800	10650	10400	
SA-268	TP430	...	16 Cr	60000	(4)(9)	12750	12750	12000	11400	11050	10650	10400	10100	9800	
SA-312	TP304	...	18 Cr-8 Ni	75000	(1)(4)(10)	16000	14450	13600	13150	12800	12700	12650	12600	12500	
SA-312	TP304	...	18 Cr-8 Ni	75000	(4)(10)	16000	14150	12750	11600	10600	9850	9500	9200	8850	
SA-312	TP304L	...	18 Cr-8 Ni	70000	(1)(4)	14900	14500	13600	12750	11900	11050	10600	10200	9800	
SA-312	TP304L	...	18 Cr-8 Ni	70000	(4)	14900	13000	11150	9350	8250	7650	7450	7200	7050	
SA-312	TP309	...	25 Cr-12 Ni	75000	(4)(10)	16000	16000	14750	14200	14100	14050	14000	13950	13800	
SA-312	TP310	...	25 Cr-20 Ni	75000	(2)(4)(10)	16000	16000	15750	15500	15050	14600	14400	14100	13800	
SA-312	TP310	...	25 Cr-20 Ni	75000	(3)(4)(10)	16000	16000	15750	15500	15050	14600	14400	14100	13800	
SA-312	TP316	...	16 Cr-13 Ni-3 Mo	75000	(4)(10)	16000	16000	15200	14900	14600	14550	14500	14450	14350	
SA-312	TP316L	...	18 Cr-12 Ni-2 Mo	70000	(1)(4)	14900	13490	13450	12550	11900	11600	11400	11250	11050	
SA-312	TP316L	...	18 Cr-12 Ni-2 Mo	70000	(4)	14900	13800	12300	10200	9350	8650	8350	8050	7750	
SA-312	TP317	...	18 Cr-13 Ni-4 Mo	75000	(4)(10)	16000	16000	15200	14900	14600	14550	14500	14450	14350	
SA-312	TP321	...	18 Cr-10 Ni-Ti	75000	(4)(10)	16000	16000	14450	13400	12900	12700	12650	12600	12500	
SA-312	TP347	...	18 Cr-10 Ni-Cb	75000	(4)(10)	16000	16000	14450	13400	12900	12700	12650	12600	12500	
SA-312	TP348	...	18 Cr-10 Ni-Cb	75000	(4)(10)	16000	16000	14450	13400	12900	12700	12650	12600	12500	
<b>FORGINGS</b>															
SA-182	F6	410	13 Cr	85000	...	21250	20400	19750	19000	18500	18100	17900	17500	17050	
SA-182	F304	304	18 Cr-8 Ni	70000	(1)(10)	17500	15850	14950	14400	14100	13900	13850	13800	13760	
SA-182	F304	304	18 Cr-8 Ni	70000	(10)	17500	15850	14800	13650	12500	11600	11200	10800	10400	
SA-182	F304L	304L	18 Cr-8 Ni	65000	(1)	16250	15850	15400	15000	14000	13000	12500	12000	11500	
SA-182	F304L	304L	18 Cr-8 Ni	65000	...	16250	14550	12850	11000	9700	9000	8750	8500	8300	
SA-182	F321	321	18 Cr-8 Ni-Ti	70000	(10)	17500	17500	15850	14750	14200	13900	13850	13800	13700	
SA-182	F347	347	18 Cr-8 Ni-Cb	70000	(10)	17500	17500	15850	14750	14200	13900	13850	13800	13700	
SA-182	F348	348	18 Cr-8 Ni-Cb	70000	(10)	17500	17500	15850	14750	14200	13900	13850	13800	13700	
SA-182	F316	316	18 Cr-8 Ni-3 Mo	70000	(10)	17500	17500	16700	16350	16050	15950	15900	15850	15800	
SA-182	F316L	316L	17 Cr-12 Ni-2 Mo	65000	(1)	16250	15750	15250	14750	14000	13600	13450	13250	13000	
SA-182	F316L	316L	17 Cr-12 Ni-2 Mo	65000	...	16250	14850	13450	12000	11000	10150	9800	9450	9100	
SA-182	F310	310	25 Cr-20 Ni	75000	(2)(10)	18750	18750	18500	18200	17700	17200	16900	16600	16250	
SA-182	F310	310	25 Cr-20 Ni	75000	(3)(10)	18750	18750	18500	18200	17700	17200	16900	16600	16250	
SA-336	F6	410	13 Cr	75000	...	18750	18100	17500	16900	16400	16000	15700	15400	15100	
SA-336	F8	304	18 Cr-8 Ni	75000	(1)(10)	18750	17000	16000	15450	15100	14900	14850	14800	14700	
SA-336	F8	304	18 Cr-8 Ni	75000	(10)	18750	16650	15000	13650	12500	11600	11200	10800	10400	
SA-336	F8t	321	18 Cr-8 Ni-Ti	75000	(10)	18750	18750	17000	15800	15200	14900	14850	14800	14700	
SA-336	F8c	347	18 Cr-8 Ni-Cb	75000	(10)	18750	18750	17000	15800	15200	14900	14850	14800	14700	
SA-336	F8m	316	18 Cr-8 Ni-3 Mo	75000	(10)	18750	18750	17900	17500	17200	17100	17050	17000	16900	
SA-336	F25	310	25 Cr-20 Ni	95000	(10)	23750	23750	23750	23200	22400	21500	20850	20000	18500	
<b>CASTINGS</b>															
SA-351	CA15	...	13 Cr-1/2 Mo	90000	(6)	22500	22500	22500	22500	22500	22000	21600	20700	19600	
SA-351	CF8	...	18 Cr-8 Ni	70000	(1)(6)(11)	17500	16500	15600	15000	14600	14350	14200	14050	13850	
SA-351	CF8	...	18 Cr-8 Ni	70000	(6)(10)	17500	15700	14250	13100	12200	11700	11500	11300	11100	
SA-351	CF8M	...	18 Cr-9 Ni-2 1/4 Mo	70000	(1)(6)(11)	17500	16900	16500	16400	16350	16300	16250	16200	16100	
SA-351	CF8M	...	18 Cr-9 Ni-2 1/4 Mo	70000	(6)(10)	17500	16900	16500	16300	15900	15350	15000	14700	14350	
SA-351	CF8C	...	18 Cr-9 Ni-Cb	70000	(1)(6)(11)	17500	17100	16600	16100	15500	14700	14200	13700	13300	
SA-351	CF8C	...	18 Cr-9 Ni-Cb	70000	(6)(10)	17500	17000	15600	14200	13000	12200	11900	11700	11600	
SA-351	CH8	...	25 Cr-13 Ni	65000	(6)(10)	16250	15700	15150	14600	14550	14450	14400	14350	14300	
SA-351	CH20	...	25 Cr-13 Ni	70000	(6)(10)	17500	16100	15150	14600	14550	14450	14400	14350	14300	
SA-351	CK20	...	25 Cr-20 Ni	65000	(6)(10)	16250	15300	14900	14600	14550	14450	14400	14350	14300	
<b>BOLTING</b>															
SA-193	B6	416	12 Cr	...	(5)	20000	19300	18700	18300	17850	17000	16500	15750	14900	
SA-193	B8T	321	18 Cr-8 Ni-Ti	75000	(5)(7)(10)	15000	15000	13600	12650	12200	11900	11850	11800	11750	
SA-193	B8C	347	18 Cr-8 Ni-Cb	75000	(5)(7)(10)	15000	15000	13600	12650	12200	11900	11850	11800	11750	
SA-193	B8	304	18 Cr-8 Ni	75000	(5)(7)(10)	15000	13300	12000	10900	10000	9300	8950	8650	8300	
SA-193	B8M	316	18 Cr-10 Ni-2 Mo	75000	(5)(7)(10)	15000	15000	13600	12650	12200	11900	11850	11800	11750	
SA-193	B6	410	13 Cr	...	(5)	20000	19300	18700	18300	17850	17000	16500	15750	14900	
SA-320	(10 Grades)	...	...	...	(5)(7)(8)	...	...	...	...	...	...	...	...	...	

Notes: The stress values in this table may be interpolated to determine values for intermediate temperatures.  
 Stress values in restricted shear such as dowel bolts, rivets, or similar construction in which the shearing member is so restricted that the section under consideration would fail without reduction of area shall be 0.80 times the values in the above table.  
 Stress values in bearing shall be 1.60 times the values in the above table.  
 (1) Due to the relatively low yield strength of this material, the higher stress values at temperatures from 200 through 1050 F were established to permit the use of this material where slightly greater deformation is acceptable. The stress values within the above range exceed 62 1/2 per cent, but do not exceed 90 per cent of the yield strength at temperature. These stress values are not recommended for the design of flanges or piping.  
 (2) These stress values at temperatures of 1050 F and above should be used only when assurance is provided that the steel has a predominant grain size not finer than ASTM No. 6.  
 (3) These stress values shall be considered basic values to be used when no effort is made to control or check the grain size of the steel.

TABLE UHA-23 MAXIMUM ALLOWABLE STRESS VALUES IN TENSION FOR HIGH-ALLOY STEEL, IN POUNDS PER SQUARE INCH (continued)

For Metal Temperatures Not Exceeding Deg F															Material and Specification	
800	850	900	950	1000	1050	1100	1150	1200	1250	1300	1350	1400	1450	1500	Number	Grade
10400	10400	...	...	...	...	...	...	...	...	...	...	...	...	...	SA-249	TP316L
7500	7200	...	...	...	...	...	...	...	...	...	...	...	...	...	SA-249	TP316L
14250	14000	13600	12800	11900	10400	8850	7200	5800	4500	3400	2550	2000	1550	1300	SA-249	TP317
12350	12150	12000	11800	11500	11100	10600	6800	4250	3050	2300	1700	1300	1000	850	SA-249	TP321
12350	12150	12000	11800	11500	11100	10600	6800	4250	3050	2300	1700	1300	1000	850	SA-249	TP347
12350	12150	12000	11800	11500	11100	10600	6800	4250	3050	2300	1700	1300	1000	850	SA-249	TP348
9350	8600	7750	6800	3400	...	...	...	...	...	...	...	...	...	...	SA-268	TP405
10150	9850	9350	7500	5450	3750	2450	1500	850	...	...	...	...	...	...	SA-268	TP410
9450	9000	8500	7900	5500	3800	2700	2050	1500	...	...	...	...	...	...	SA-268	TP430
12400	12150	11900	11400	10600	8500	6400	4900	3800	2750	2100	1550	1200	850	650	SA-312	TP304
8500	8250	8000	7750	7500	7200	6400	4900	3800	2750	2100	1550	1200	850	650	SA-312	TP304
9350	...	...	...	...	...	...	...	...	...	...	...	...	...	...	SA-312	TP304L
6900	...	...	...	...	...	...	...	...	...	...	...	...	...	...	SA-312	TP304L
13350	12700	11700	10600	8900	7200	5500	4250	3250	2450	1950	1500	1100	750	650	SA-312	TP309
13350	12700	11700	10600	9350	8300	7200	6150	5100	4050	3000	2000	1350	950	650	SA-312	TP310
13350	12700	11700	10600	9350	6000	4250	3050	2100	1250	650	400	300	200	150	SA-312	TP310
14250	14000	13600	12800	11900	10400	8850	7200	5800	4500	3400	2550	2000	1550	1300	SA-312	TP316
10800	10400	...	...	...	...	...	...	...	...	...	...	...	...	...	SA-312	TP316L
7800	7200	...	...	...	...	...	...	...	...	...	...	...	...	...	SA-312	TP316L
14250	14000	13600	12800	11900	10400	8850	7200	5800	4500	3400	2550	2000	1550	1300	SA-312	TP317
12350	12150	12000	11800	11500	11100	10600	6800	4250	3050	2300	1700	1300	1000	850	SA-312	TP321
12350	12150	12000	11800	11500	11100	10600	6800	4250	3050	2300	1700	1300	1000	850	SA-312	TP347
12350	12150	12000	11800	11500	11100	10600	6800	4250	3050	2300	1700	1300	1000	850	SA-312	TP348
<b>FORGINGS</b>																
16300	14000	11000	8800	6400	4400	2900	1750	1000	...	...	...	...	...	...	SA-182	F6
13600	13350	13050	12800	12500	10000	7500	5750	4500	3250	2450	1800	1400	1000	750	SA-182	F304
10000	9700	9400	9100	8800	8500	7500	5750	4500	3250	2450	1800	1400	1000	750	SA-182	F304
11000	...	...	...	...	...	...	...	...	...	...	...	...	...	...	SA-182	F304L
8100	...	...	...	...	...	...	...	...	...	...	...	...	...	...	SA-182	F304L
13650	13600	13600	13550	13500	13100	10300	7600	5000	3300	2200	1500	1200	900	750	SA-182	F321
13650	13600	13600	13550	13500	13100	10300	7600	5000	3300	2200	1500	1200	900	750	SA-182	F347
13650	13600	13600	13550	13500	13100	10300	7600	5000	3300	2200	1500	1200	900	750	SA-182	F348
15650	15400	14950	14500	14000	12200	10400	8500	6800	5300	4000	2700	2000	1500	1000	SA-182	F316
12700	12250	...	...	...	...	...	...	...	...	...	...	...	...	...	SA-182	F316L
8800	8500	...	...	...	...	...	...	...	...	...	...	...	...	...	SA-182	F316L
15700	14900	13800	12500	11000	9750	8500	7250	6000	4750	3500	2350	1600	1100	750	SA-182	F310
15700	14900	13800	12500	11000	7100	5000	3600	2500	1450	750	450	350	250	200	SA-182	F310
14650	14000	11000	8800	6400	4400	2900	1750	1000	...	...	...	...	...	...	SA-336	F6
14550	14300	14000	13400	12500	10000	7500	5750	4500	3250	2450	1800	1400	1000	750	SA-336	F8
10000	9700	9400	9100	8800	8500	7500	5750	4500	3250	2450	1800	1400	1000	750	SA-336	F8
14550	14300	14100	13850	13500	13100	12500	8000	5000	3600	2700	2000	1550	1200	1000	SA-336	F8t
14550	14300	14100	13850	13500	13100	12500	8000	5000	3600	2700	2000	1550	1200	1000	SA-336	F8c
16750	16500	16000	15100	14000	12200	10400	8500	6800	5300	4000	3000	2350	1850	1500	SA-336	F8m
17000	15500	14000	12500	11000	9750	8500	7250	6000	4750	3500	2350	1600	1100	750	SA-336	F25
<b>CASTINGS</b>																
18300	16000	11000	7600	5000	3300	2200	1500	1000	...	...	...	...	...	...	SA-351	CA15
13600	13350	13000	12600	12100	9600	7500	5750	4500	3250	2450	1800	1400	1000	750	SA-351	CF8
10900	10650	10400	10100	9850	9600	7500	5750	4500	3250	2450	1800	1400	1000	750	SA-351	CF8
15900	15500	15000	13500	12000	10600	9400	8000	6800	5300	4000	3000	2350	1850	1500	SA-351	CF8M
14000	13500	13000	12350	11700	10600	9400	8000	6800	5300	4000	3000	2350	1850	1500	SA-351	CF8M
12900	12600	12300	11900	11600	11200	10800	8000	5000	3600	2700	2000	1550	1200	1000	SA-351	CF8C
11500	11350	11200	11100	11000	10900	10800	8000	5000	3600	2700	2000	1550	1200	1000	SA-351	CF8C
14150	13900	13500	12500	10500	8500	6500	5000	3800	2900	2300	1750	1300	900	750	SA-351	CF8
14150	13900	13500	12500	10500	8500	6500	5000	3800	2900	2300	1750	1300	900	750	SA-351	CH20
14150	13900	13500	12500	11000	9750	8500	7250	6000	4750	3500	2350	1600	1100	750	SA-351	CK20
<b>BOLTING</b>																
13800	12500	11000	...	...	...	...	...	...	...	...	...	...	...	...	SA-193	B6
11650	11450	11300	11100	10800	10500	10000	8000	5000	3600	2700	2000	1550	1200	1000	SA-193	B8T
11650	11450	11300	11100	10800	10500	10000	8000	5000	3600	2700	2000	1550	1200	1000	SA-193	B8C
8000	7750	7500	7250	7050	6800	6300	5750	4500	3250	2450	1800	1400	1000	750	SA-193	B8
11650	11450	11300	11100	10800	10500	10000	8500	6800	5300	4000	3000	2350	1850	1500	SA-193	B8M
13800	12500	11000	...	...	...	...	...	...	...	...	...	...	...	...	SA-193	B6
...	...	...	...	...	...	...	...	...	...	...	...	...	...	...	SA-320	{10 Grades

(4) These stress values are the basic values multiplied by a joint efficiency factor of 0.85.  
 (5) These stress values are established from a consideration of strength only and will be satisfactory for average service. For bolted joints where freedom from leakage over a long period of time without retightening is required, lower stress values may be necessary as determined from the flexibility of the flange and bolts and corresponding relaxation properties.  
 (6) To these stress values a quality factor as specified in Par. UG-24 shall be applied.  
 (7) These stress values permitted for material that has been carbide-solution treated.  
 (8) For temperatures below 100 F, stress values equal to 20 per cent of the specified minimum tensile strength will be permitted.  
 (9) This steel may be expected to develop embrittlement at room temperature after service at temperatures above 800 F; consequently, its use at higher temperatures is not recommended unless due caution is observed.  
 (10) These stress values apply only when the carbon is 0.04 per cent or higher.  
 (11) For temperatures above 800 F, the stress values apply only when the carbon content is 0.04 per cent and above.

Par. 6.6 Fig. 1

POROSITY CHARTS

A.S.M.E. UNFIRED PRESSURE VESSEL CODE

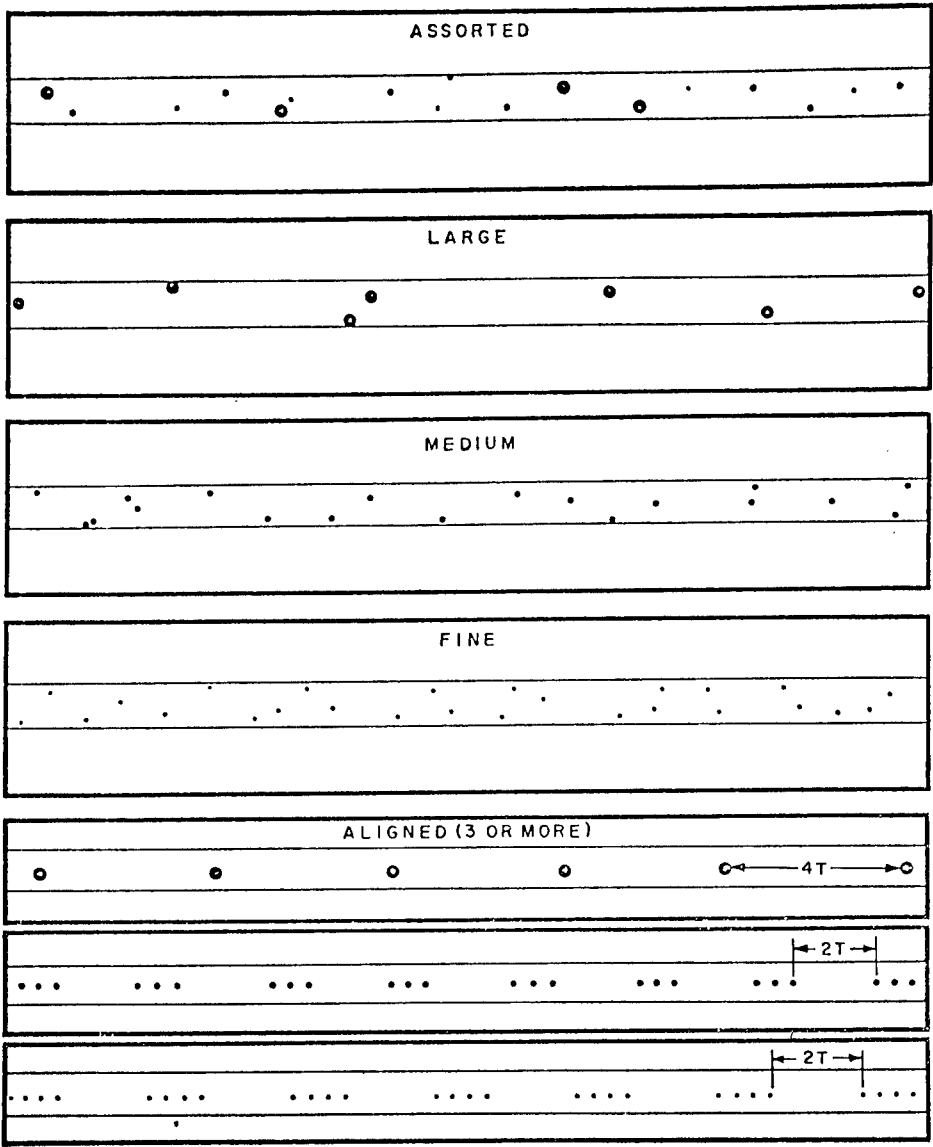

PLATE  $\frac{1}{4}$  IN. OR LESS

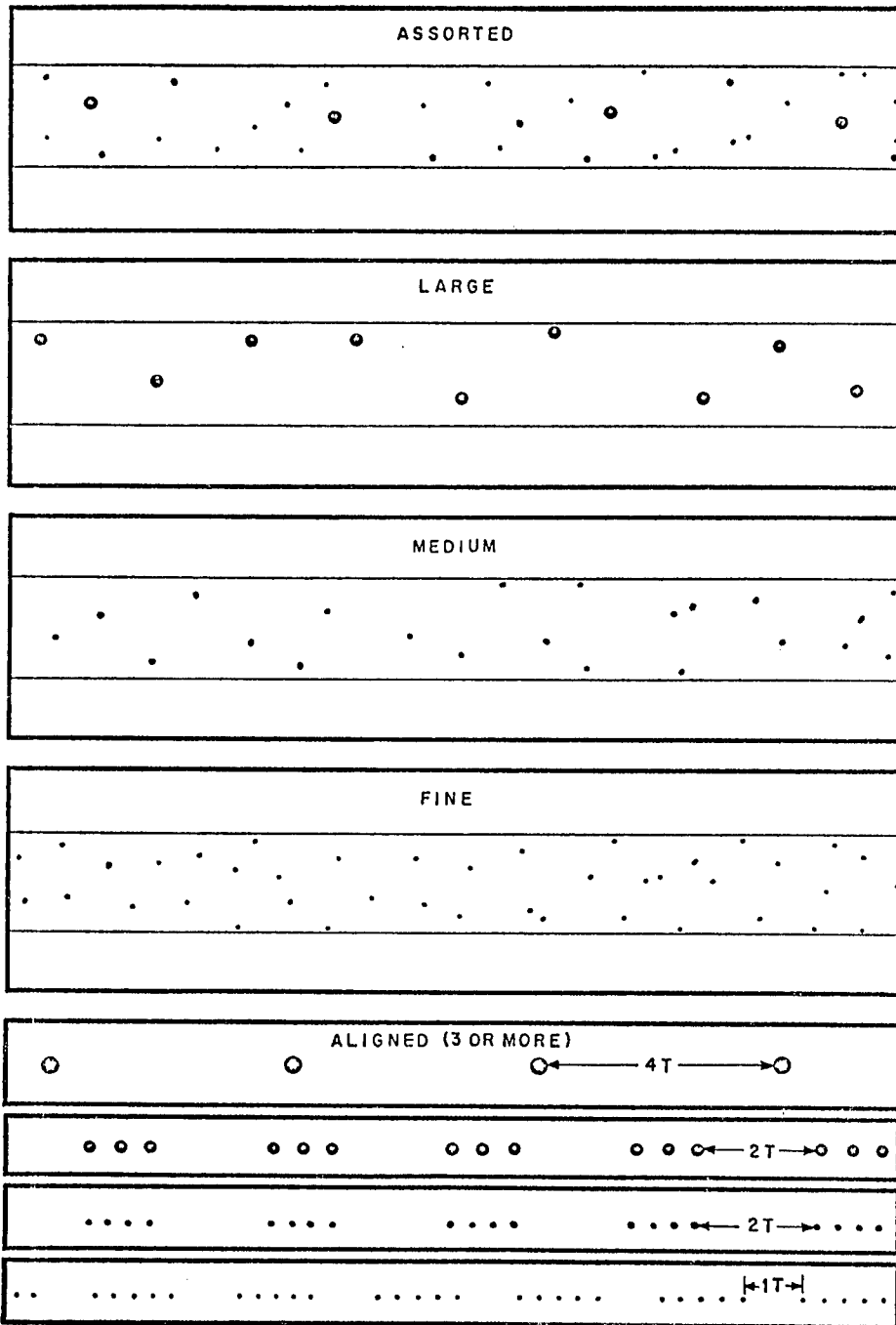

PLATE OVER  $\frac{1}{4}$  IN. TO  $\frac{1}{2}$  IN.

Par. 6.6 Fig. 3

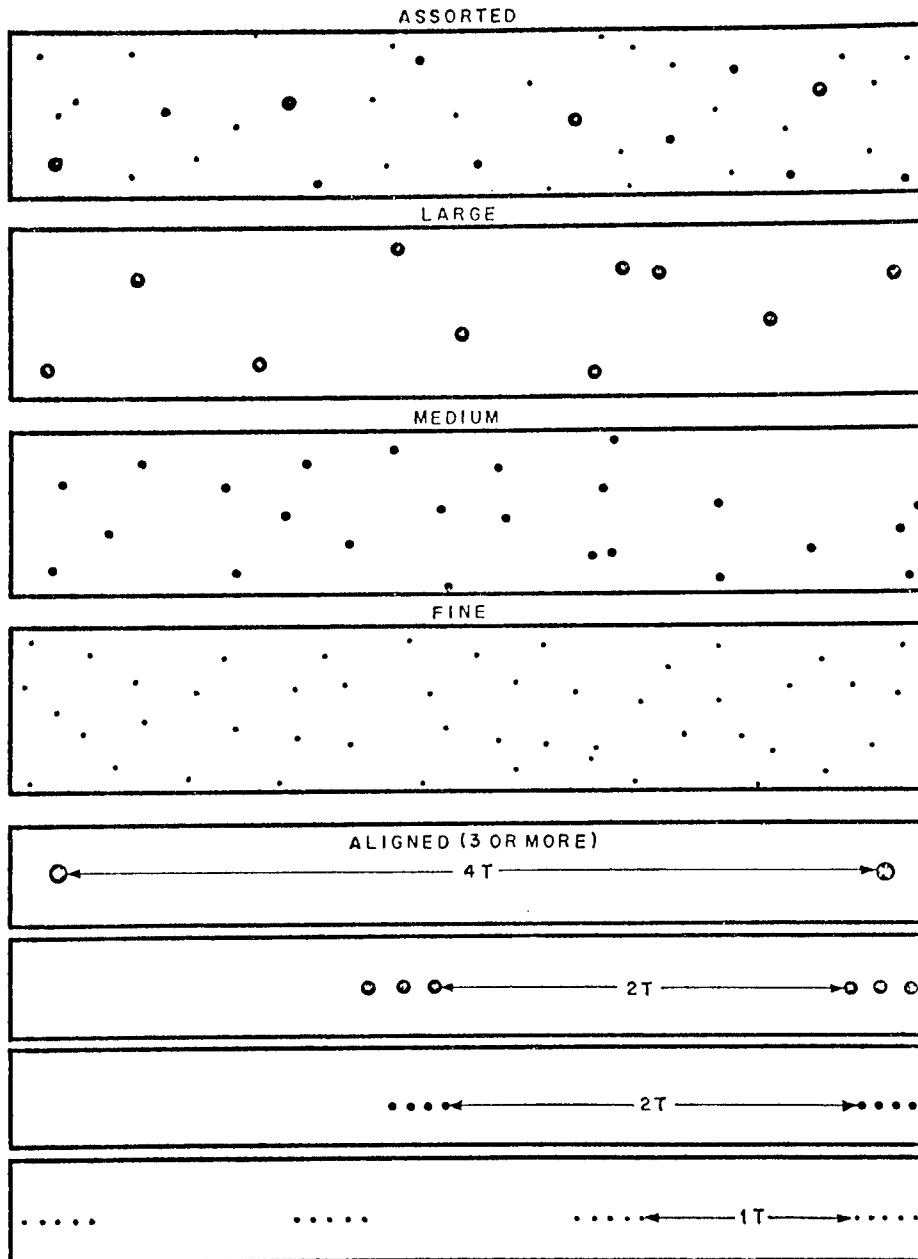
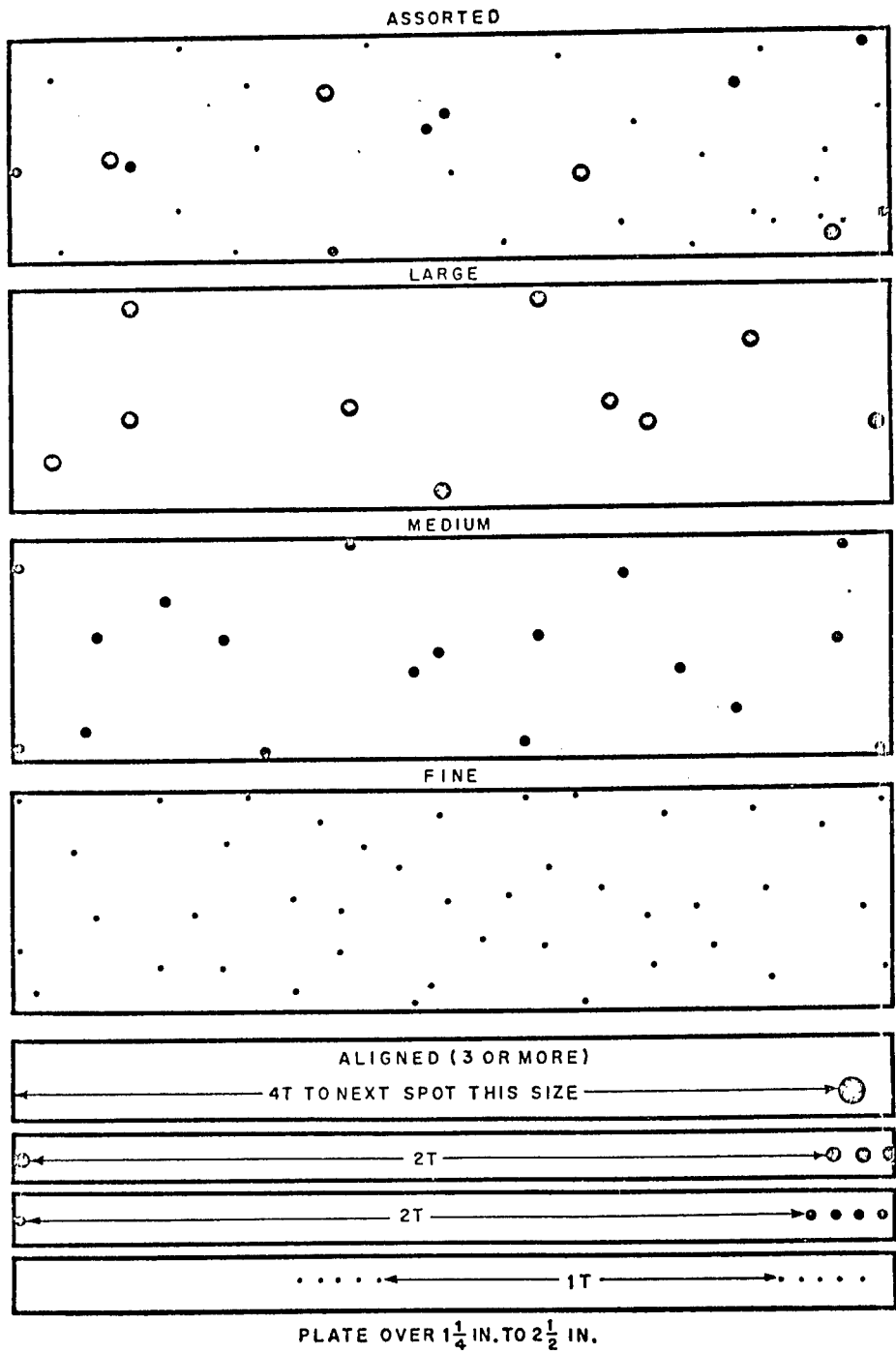
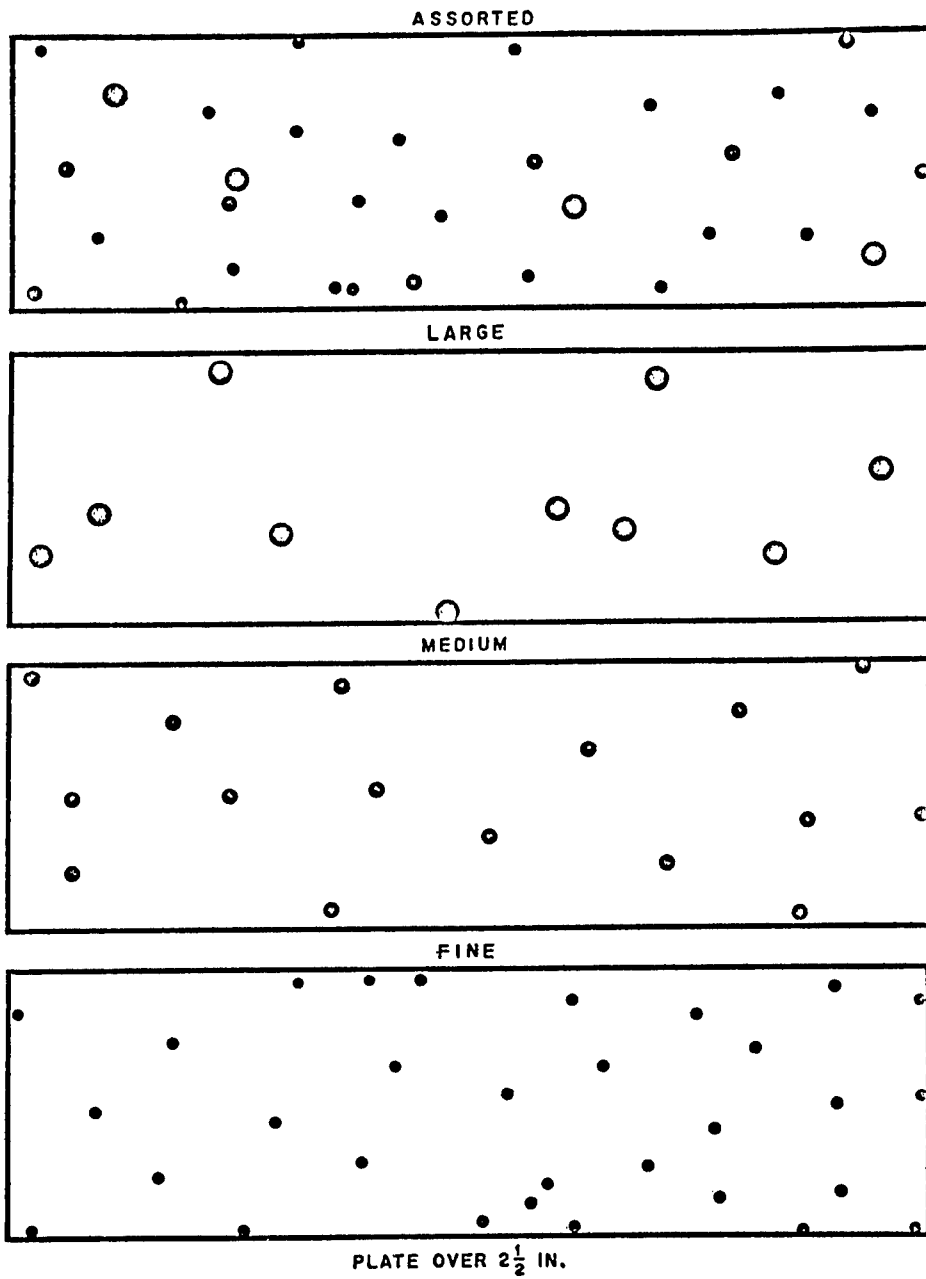

PLATE OVER  $\frac{1}{2}$  IN. TO  $1\frac{1}{4}$  IN.



Par. 6.6 Fig. 5



See Figure 6 for aligned porosity chart for plate over 2-1/2 in. thick.

Par. 6.6 Fig. 6

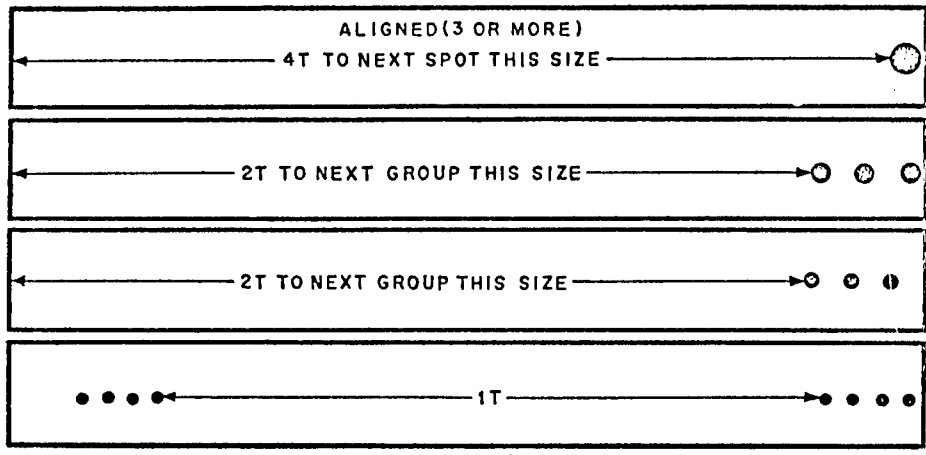

PLATE OVER 2 1/2 IN.

### Inspection and Testing of Steel Castings

**UA-80** All steel castings shall be inspected in accordance with (a) or (b) as applicable.

(a) All steel castings 4 in. or less in body thickness (other than those made to an accepted standard such as ASA B16.5-1961) shall be inspected as follows:

(1) All critical sections<sup>1</sup> shall be radiographed. Radiographs shall conform to requirements of ASTM Specification E71-52, Industrial Radiographic Standards for Steel Castings. Castings shall meet Class 1 if wall thickness is less than 1 in.; Class 2 if 1 in. or over, as defined in ASTM Specification E71-52.

(2) All surfaces, including machined gasket seating surfaces, shall be examined by magnetic particle inspection. In the case of nonmagnetic materials, liquid penetrant methods shall be used.

Indications exceeding Degree 3 of Types I, II, and III and exceeding Degree 1 of Types IV and V of ASTM Specification E125-56T shall be removed. The technique for magnetic particle inspection shall be in accordance with ASTM Specification E109-57T.

(3) Where more than one casting of a particular design is produced, each of the first five castings shall be inspected as above. Where more than five castings are being produced, the examination shall be performed on the first five, plus one additional casting to represent each five additional castings. If this additional casting proves to be unacceptable, each of the remaining four castings in the group shall be inspected.

(4) Castings of non-weldable materials which contain discontinuities in excess of the maximum permitted in (a)(1) and (a)(2) shall be rejected. Such discontinuities may be removed from weldable castings, and the castings may be repaired by welding after the base metal has been inspected to assure complete removal of discontinuities. The completed repair shall be re-inspected by the same method used in the original inspection. The repaired casting shall be stress-relieved.

(5) All welding shall be performed using welding procedure qualification in accordance with Section IX. The procedure qualification shall be performed on a test specimen of cast material of the same specification and subjected to the heat-treatment before and after welding as will be applied to the work. All welders and operators performing this welding shall be qualified in accordance with Section IX.

<sup>1</sup> *Critical Sections:* The sections where defects are usually encountered, such as the junction of risers, gates, or feeders to the castings, and at abrupt changes in section.

(b) All castings having a body greater than 4 in. nominal thickness and castings of lesser thickness which are intended for extremely severe applications<sup>2</sup> shall be inspected as follows:

(1) Each casting shall be subjected to 100 per cent visual and magnetic particle inspection of all surfaces after heat-treatment. In the case of nonmagnetic materials, liquid penetrant methods shall be used. All Type I indications of ASTM Specification E-125-56T and all indications exceeding Degree 1 of Types II, III, IV, and V shall be removed. The inspection technique shall be in accordance with ASTM Specification E-109-57T.

(2) All parts of castings up to 12 in. in thickness shall be subjected to complete radiographic inspection and the radiographs shall conform to the requirements of ASTM Specification E-71-52, Industrial Radiographic Standards for Steel Castings. Castings shall meet Class 1 if wall thickness is less than 1 in.; Class 2 if 1 in. or over, as defined in ASTM Specification E-71-52.

(3) All parts of castings in excess of 12 in. in thickness which are not radiographed shall be ultrasonically examined in accordance with the procedures given in ASTM Specification E-114-55T. Any discontinuities whose reflections do not exceed a height equal to 20 per cent of the normal Back Reflection or do not reduce the height of the Back Reflection by more than 30 per cent during movement of the transducer 2 in., in any direction, shall be considered acceptable. Indications exceeding those limits shall be repaired unless proved to be acceptable by other test methods. The above limits are established with the use of transducers having approximately 1 sq in. of area.

(4) Any discontinuities in excess of the maximum permitted in Pars. (b)(1), (b)(2), and (b)(3) shall be removed and the castings may be repaired by welding after the base metal has been magnetic particle inspected (or for nonmagnetic materials, liquid penetrant inspected) to assure complete removal of discontinuities.

(5) All weld repairs of depth exceeding 1 in. or 20 per cent of the section thickness, whichever is the lesser, shall be inspected by radiography in accordance with Par. (b)(2) and by magnetic particle (or liquid penetrant) inspection of the

<sup>2</sup> The Code as currently written provides minimum requirements for construction and it is recognized to be the responsibility of the designing engineer to determine when the intended service is of a nature that requires supplementary requirements to insure safety; consequently, the designs should determine when the service warrants that this class of inspection be specified for steel castings of less than 4 in. nominal body thickness.

Inspection and Testing of Steel Castings (Cont'd.)

finished weld surface. All weld repairs of depth less than 20 per cent of the section thickness, or 1 in., whichever is the lesser, and all weld repairs of sections which cannot be effectively radiographed shall be examined by magnetic particle (or liquid penetrant) inspection of the first layer of each  $\frac{1}{4}$  in. thickness of deposited weld metal and of the finished weld surface. Weld repairs resulting from the ultrasonic inspection shall be inspected by the same method. Magnetic particle (or liquid penetrant) testing of the finished weld surface shall be done after stress-relieving.

(c) When repair welding is done after heat-treatment of the casting, the casting shall be stress-relieved.

(7) All welding shall be performed using welding procedure qualification in accordance with Section IX. The procedure qualification shall be performed on test specimen of cast material of the same specification and subjected to the heat-treatment before and after welding as will be applied to the work. All welders and operators performing this welding shall also be qualified in accordance with Section IX.

(c) *Identification and Marking* Each casting shall be marked with the manufacturer's name and the casting identification, including material designation. The manufacturer shall furnish reports of the chemical and mechanical properties and certification that each casting conforms to all the applicable requirements.

## 7.1 - 7.1.1

### 7. HEAT TREATMENT

#### 7.1 Austenitic Stainless Steels

##### 7.1.1 Carbide Solution Anneal

In the austenitic stainless steels, the greatest degree of corrosion resistance is realized in the solution annealed condition. In this condition, all of the chromium, which is the primary source of the corrosion resistance of the stainless steels, is in solid solution. If solution annealed material is heated so that chromium carbides are precipitated (the precipitation normally occurring at grain boundaries and slip planes), the corrosion resistance at the grain boundaries is reduced and intergranular attack will result in several media, notably boiling nitric acid. Additional information on the subject of intergranular attack may be found in Par. 3.2.

The purpose of the solution anneal is to redissolve chromium carbides. The carbide solution anneal is normally performed in the temperature range 1950-2050°F., the material remaining at heat for one hour per inch of thickness, followed by rapid cooling utilizing water quenching, water spray, and air blast. Although carbides form rapidly when heating annealed regular carbon material such as Type 304 into the sensitizing range, the formation of carbides on cooling through the same sensitizing temperature range proceeds at a much slower rate. For this reason, cooling of equipment items to black color in no longer than three minutes from the time the furnace door is opened is permitted.

The information listed below\* shows the effect on corrosion rate in boiling 65% nitric acid after reheating annealed Type 304 and Type 316 material from typical heats into the sensitizing and solution annealing ranges.

<u>Heat Treatment</u>	<u>Corrosion Rate, In./Mo.</u>	
	<u>Type 304 (.077% C)</u>	<u>Type 316 (.062% C)</u>
As Received*	0.00052	0.00090
1 hr. 1000°F., W.Q.**	0.00128	0.00142
1 hr. 1050°F., W.Q.	0.00133	0.0375
1 hr. 1100°F., W.Q.	0.00676	0.0430
1 hr. 1150°F., W.Q.	0.0205	0.0411
1 hr. 1200°F., W.Q.	0.0137	0.0384
1 hr. 1250°F., W.Q.	0.0145	0.0407
1 hr. 1300°F., W.Q.	0.00884	0.0308
1 hr. 1400°F., W.Q.	0.00292	0.0149
1 hr. 1500°F., W.Q.	0.00097	0.00324

\*Results of unpublished research at the Du Pont Engineering Materials Laboratory by E. A. Kachik, now with the Du Pont Engineering Department, Engineering Service Division.

Heat Treatment	Corrosion Rate, In./Mo.	
	Type 304 (.077% C)	Type 316 (.062% C)
1 hr. 1600°F., W.Q.	0.00073	0.00155
1 hr. 1700°F., W.Q.	0.00068	0.00147
1 hr. 1750°F., W.Q.	0.00064	0.00132
1 hr. 1800°F., W.Q.	0.00058	0.00117
1 hr. 1850°F., W.Q.	0.00058	0.00102
1 hr. 1900°F., W.Q.	0.00049	0.00090
1 hr. 1950°F., W.Q.	0.00053	0.00096
1 hr. 2000°F., W.Q.	0.00053	0.00090
1 hr. 2100°F., W.Q.	0.00054	0.00088
1 hr. 2200°F., W.Q.	0.00058	0.00091
1 hr. 2300°F., W.Q.	0.00055	0.00089
1 hr. 2400°F., W.Q.	0.00059	0.00111

\* As received material had been held 1 hr. at 1950°F. and water quenched

\*\* W.Q. = water quench

### 7.1.2 Stabilization

Stabilization is a term commonly applied to heat treatments performed on columbium and titanium stabilized grades to achieve the maximum corrosion resistance in Type 321, and to prevent knife-line attack in both the titanium and columbium stabilized grades when the sequence of welding and of sensitizing heat treatment followed by exposure to severe corrodents will be experienced. See Par. 3.8 for information on knife-line attack.

When Type 321 stainless steel is in the solution annealed condition, titanium carbides will have been dissolved. Subsequent exposure to the sensitizing temperature range of 1000-1400°F. will cause some precipitation of chromium carbides before the titanium carbides can form and tie up the carbon. When the chromium carbides form, the material is not completely resistant to intergranular attack in strong corrodents such as boiling HNO<sub>3</sub>. To assure maximum resistance to corrosion when a Type 321 part will be subjected to the sensitizing temperature range, the part should be given a prior treatment of from two to five hours at

## 7.1.2 - 7.1.3.1

1550-1650°F. Heating for prolonged periods of time over 1700°F. will redissolve the titanium carbides. Once the titanium carbides have been precipitated, exposure in the sensitizing temperature range will not seriously affect corrosion resistance.

In the case of Type 347 stainless steel, stabilizing heat treatments are not normally required unless (1) the part has been solution annealed at temperatures which will dissolve columbium carbides (approximately 2100°F. and higher) or (2) the material has been welded and if, prior to exposure to solutions capable of causing intergranular attack, the part is subjected to temperatures in the sensitizing range. If the material has been heat treated as indicated above, it should be stabilized at 1600-2000°F. This will precipitate columbium carbides in the range where conditions are unfavorable for the precipitation of chromium carbides.

### 7.1.3 Stress Relieving

#### 7.1.3.1 General<sup>1</sup>

No hard and fast set of rules can be set up to cover stress relieving of austenitic stainless steels. A knowledge of their characteristics and the exercise of careful judgment are the only suggestions which can be made. In all cases the service requirements govern. Evaluation of these service requirements coupled with careful consideration of the basic steel characteristics dictate the type of heat treatment, if any, which the engineer must specify. Some situations where stress relieving could be beneficial are listed below:

- a. Where the service environment is conducive to stress corrosion. (Author's note: and where it is not possible to prevent stress corrosion by altering the environment or by the use of resistant materials of construction.)
- b. When dimensional stability is required. This may include dimensional stability in machining operations or during subsequent service where nonuniform stress relaxation might occur.
- c. In some cases, life under cyclic loading might be diminished by high residual stresses. This is a minor consideration, however, with the austenitic grades.

<sup>1</sup>Huseby, R.A., "Stress Relieving of Stainless Steels and the Associated Metallurgy," Welding Journal, Vol. 37, 304S-315S, (July, 1958).

- d. In extremely heavy sections, welding may impose a multi-axial stress system which severely limits ductility. Stress relief is one way of correcting this condition. (Precautions regarding the stress relief of highly stressed Type 347 must be taken to avoid cracking.)

#### 7.1.3.2 A.S.M.E. Code Opinion Regarding Stress Relieving

The A.S.M.E. Unfired Pressure Vessel Code, 1962 edition, Par. UHA-32, makes the following statement on thermal stress relieving:

"Heat treatment, including stress relief, of welded vessels constructed of austenitic chromium-nickel stainless steels is neither required nor prohibited. The need for and the details of heat treatment depend on the type of alloy steel and service conditions. The Nonmandatory Appendix to this Part gives some general suggestions."

Nonmandatory Appendix HA, Par. UHA-105, on the heat treatment of austenitic chromium-nickel stainless steels includes the following statements:

"In recognition of controversial opinion relative to the effects of thermal stress relief of austenitic stainless steels, mandatory requirements for such have been omitted. Service experience is too limited to permit comparison between the relative safety of as-welded and stress-relieved austenitic steel weldments, particularly in thick sections. It is recognized that the stability of austenitic steels and their optimum behavior in service are influenced by the mechanical and thermal treatments that they have received; however, it is a basic principle that the Code rules are intended to provide minimum safety requirements for new construction, not to cover deterioration which may occur in service as a result of corrosion, instability of the material, or unusual operating conditions such as fatigue or shock loading."

#### 7.1.3.3 Recommended Temperatures and Times

It is generally recommended that austenitic stainless steel weldments which require stress relieving be heated to 1600-1750°F., held for one to three hours, and then air cooled.

### 7.1.3.3 - 7.1.3.4

Tests conducted by L. H. Satz of General Electric and reported in the article "Stress Relief of Stainless Type 347 Investigated," Iron Age, Sept. 28, 1950, indicated the following effect of one hour at temperature in stress relieving Type 347 stainless steel:

<u>Temperature, °F.</u>	<u>Approx. % Stress Relief</u>
900	20
1000	25
1100	32
1200	38
1300	45
1400	54
1500	63
1600	75
1700	90

No similar data can be found for Type 304 or 304L. More stress relief should occur for these grades at a given temperature than indicated above for Type 347.

W. Fleischmann of General Electric Co. conducted additional tests on Type 347 and reported that temperatures of 1650°F. and above caused complete relaxation. G. Linnert in Welding Research Council Bulletin No. 43, "Welding Type 347 Stainless Steel Piping and Tubing," Oct., 1958, reported that practical experience with welded Type 347 piping has shown that a temperature of about 1600°F. produces adequate stress relief for virtually all applications.

#### 7.1.3.4 Effects of Stress Relief Treatments

##### a. Sensitization

Air cooling Types 304, 316, 309, and 310 from the stress relieving temperature range 1600-1750°F. will produce a degree of sensitization which is less severe than that produced by short-time heating at 1200°F. followed by air cooling. The effect of stress relieving at the higher end of the range is less severe from a corrosion standpoint than at the lower end. Thermal stresses introduced in the part being stress relieved by cooling from the higher end of the range will be more severe

than from the lower end. The values listed below\* show the effect on resistance to corrosion in boiling 65% HNO<sub>3</sub> of air cooling Type 304 specimens from three different heats from various temperatures.

<u>Heat</u>	<u>Air Cooled from Temperature, °F.</u>	<u>Corrosion Rate, in./mo.</u>
A	1200	0.006
B	"	0.014
C	"	0.027
A	1400	0.003
B	"	0.002
C	"	0.01
A	1600	0.001
B	"	0.001
C	"	0.003
A	1700	0.001
B	"	0.0007
C	"	0.002
A	1750	0.0008
B	"	0.0006
C	"	0.001

If stress relief treatments are required, the unstabilized, normal carbon range stainless steels should be avoided, if they will subsequently be exposed in even moderately corrosive environments, or if cleanliness requirements require the use of pickling for final cleaning.

In general, there should be no harmful effects from the use of stress relief treatments in the range 1600-1750°F. on the stabilized or extra low carbon austenitic stainless steel grades. Where severely corrosive environments are to be handled, corrosion tests should be conducted to evaluate the effect of any anticipated stress relieving treatments.

b. Stabilization

In the case of the stabilized austenitic Type 347 heating into the 1600-1750°F. range should be beneficial. For additional information, see Par. 7.1.2. In the

\*Results of unpublished research at the Du Pont Engineering Materials Laboratory by E. A. Kachik, now with the Du Pont Engineering Department, Engineering Service Division.

#### 7.1.3.4

case of Type 321, heating at the lower end of the range could result in beneficial stabilization, but dissolution of titanium carbide could occur at the higher end.

##### c. Sigma Phase

Some embrittlement due to formation of sigma phase may occur in grades other than 304 and 308.

---

7.2 Ferritic Stainless Steels7.2.1 Annealing

The ferritic stainless steels cannot be hardened by heat treatment since they undergo only partial or no allotropic transformation to austenite on heating. Therefore, annealing or stress relieving is the only useful heat treatment for these grades. The table below gives the recommended annealing practice for the ferritic grades.

Annealing Treatment for Ferritic Stainless Steel<sup>1</sup>

<u>Type No.</u>	<u>Temperature</u>	<u>Time(hrs.)</u>	<u>Cooling</u>
405	1200 - 1500°F.	1-2	Air cool or water quench
430	1500 - 1650°F.	1-3	100°F./hr. to 1100°F. and air cool
	or 1400 - 1525°F.	1-2	Air cool or water quench
430F.	1200 - 1450°F.	1-2	Air cool or water quench
442,443	1400 - 1525°F.	1-2	Air cool or water quench
446	1400 - 1525°F.	1-2	Air cool or water quench

Refer to Par. 6.6 for the ASME Code requirements on stress relieving of unfired pressure vessels constructed from the ferritic grades.

The ferritic stainless steels are susceptible to several phenomena produced by heat and which cause changes in the mechanical properties. These phenomena are reviewed in Par. 5.2.

Reference

- (1) Metals Handbook, Vol. 1, Properties & Selection of Metals, 8th Edition

## 7.3

### 7.3 Heat Treatment - Martensitic Stainless Steels

The recommended annealing, hardening and stress relieving temperatures for the martensitic stainless steels are listed below:

Type No.	Annealing Temp. (°F.)		Hardening Temp. (°F.)	Stress Relieving	
	Process (1)	Full (2)		Temp. °F.	Brinell Hardness
403 ) 410 ) 416 )	1350-1450	1550-1650	1700-1850 Oil quench	450-700	360-380
414 ) 431 )	1150-1250	(3)	1800-1950 Oil quench; air small parts	450-700	370-400
420	1350-1450	1600-1650	1800-1900 Air or warm oil quench	300-700	470-530
440 A ) 440 B ) 440 C )	1350-1450	1625-1675	1850-1950 Air or warm oil	300-700	500-620

- NOTE: 1) Cooling may be accomplished in air, oil or water.
- 2) Cool at maximum of 50°F./hour to 1100°F. then in air, oil or water.
- 3) These steels do not respond to slow cooling from above the critical temperature.

There are two types of annealing in common practice in this country. These are process annealing and full annealing. Process annealing refers to an isothermal treatment at just below the critical temperature. This treatment does not give complete softening.

Full annealing, however, requires heating to a temperature above the critical temperature followed by a slow cool through that temperature and for some distance below it.

Complex or large parts of the martensitic grades to be hardened should be preheated at 1450-1500, prior to placing in a furnace at hardening temperature. The high carbon grades, i.e. 420 and 440 A, B, C, should always be preheated prior to hardening.

The martensitic grades should be stress relieved immediately after hardening. With the higher carbon grades, this is most important to prevent cracking. Some heat treaters will stress relieve these grades before they cool completely in an attempt to prevent cracking.

A double tempering or stress relieving treatment is recommended on any of the high carbon grades. The necessity for this is to eliminate retained austenite which has not transformed to martensite during the quench. This retained austenite can cause cracking at a later time if not eliminated. A double temper is the most commonly used means for alleviating this difficulty.

On occasions it is desirable to use the martensitic stainless steels at hardnesses lower than are usually obtained by a low temperature tempering or stress relieving operation in order to obtain better ductility and impact strength. Par. 2.9, Tables 1 through 5, give mechanical properties vs. tempering temperatures for martensitic steel Types 403, 410, 416, 420, 431 and 440.

7.4 - 7.4.1.2

7.4 Heat Treatment of Precipitation Hardening Stainless Steels

7.4.1 17-4 PH (Armco Steel Corp.)

7.4.1.1 Condition as Supplied by Mill

17-4 PH as shipped from the mill is usually in the solution-treated condition. However, it may be supplied hardened if so desired. Material ordered for forging should be in the overaged condition. The various conditions in which the material can be purchased are listed below:

How Condition is Developed

Condition A (Solution treated)	Solution treated at 1875-1925°F., air cooled or oil quenched.
Condition H1075, or H1150 (Solution treated and aged)	Solution treated material is reheated at 1075°F. or 1150°F. for four hours and air cooled. These conditions are used for improved ductility.
Overaged for Forging	Solution-treated material is reheated at approximately 1200°F. to achieve maximum softness and eliminate possibility of cracking of large sections. Material in this condition will not respond to aging treatments without first solution treating.

7.4.1.2 Heat Treatment by User

For maximum hardness and strength, material from the solution-treated condition is heated for one hour at  $900 \pm 10^\circ\text{F}$ . and air cooled to room temperature. If the material is purchased in the solution-treated condition (Condition A) and not subsequently hot worked, the hardening treatment can be performed without solution treating before hardening.

Where ductility in the hardened condition is of importance, better toughness can be obtained by raising the temperature of the hardening heat treatment. Unlike regular hardenable materials which require a hardening plus a tempering or stress relieving treatment, 17-4 PH can be hardened to the final desired properties in one operation. By varying the heat treating procedure between 900-1150°F. for one to four hours, a wide band of properties can be attained. See the section on mechanical properties for selection of the desired heat treatment, Par. 2.10.

7.4.1.2 - 7.4.3.1

Material too strong and hard but not ductile enough in the hardened condition can be reheat-treated at a higher temperature to increase impact strength and elongation. This heat treatment can be made without a solution treatment prior to the final heat treatment.

For material hot worked or forged, or castings in the as-cast condition, a solution treatment at 1875-1925°F. one-half hour followed by air cooling to room temperature, then a water or oil quench to 90°F. or lower is recommended prior to hardening. Oil quenching rather than air cooling may be used on small, simple sections. This treatment will refine the grain size and make hardened material more uniform.

7.4.1.3 Dimensional Change During Hardening

The following information on the effect of precipitation hardening temperature on dimensional change of Armco 17-4 PH stainless steel was taken from a curve in the Armco Steel Corp. Technical Data Manual, Armco Precipitation Hardening Stainless Steels.

<u>Hardening Temp., °F.</u> <u>(held at temperature</u> <u>for one hour)</u>	<u>Contraction</u> <u>In./In.</u> <u>(approximate)</u>
900	.0005-.0006
1000	.0007
1050	.0007-.0008
1100	.0008
1150	.0013
1200	.0018

7.4.2 Stainless W (United States Steel Corp.)

This grade is similar in composition to 17-4 PH and will respond to the same heat treatments as stated above for 17-4 PH.

7.4.3 17-7 PH (Armco Steel Corp.)

7.4.3.1 Condition as Supplied by Mill

Sheet, strip, plate, bar, and wire of 17-7 PH composition are normally supplied to the user in the annealed condition, designated as Condition A. Sheet and strip .050 in. and thinner are also produced in a hard-rolled condition, designated as Condition C, for applications requiring maximum strength.

7.4.3.2

7.4.3.2 Heat Treatment by User

High strengths in parts made from 17-7 PH Condition A material are developed by three essential steps:

1. Austenite conditioning
2. Cooling to effect transformation of austenite to martensite
3. Precipitation hardening

Mechanical properties are guaranteed for three standard conditions of heat treatment - Conditions TH 1050, RH 950 and CH 900. The choice of heat treatments can be determined by design requirements.

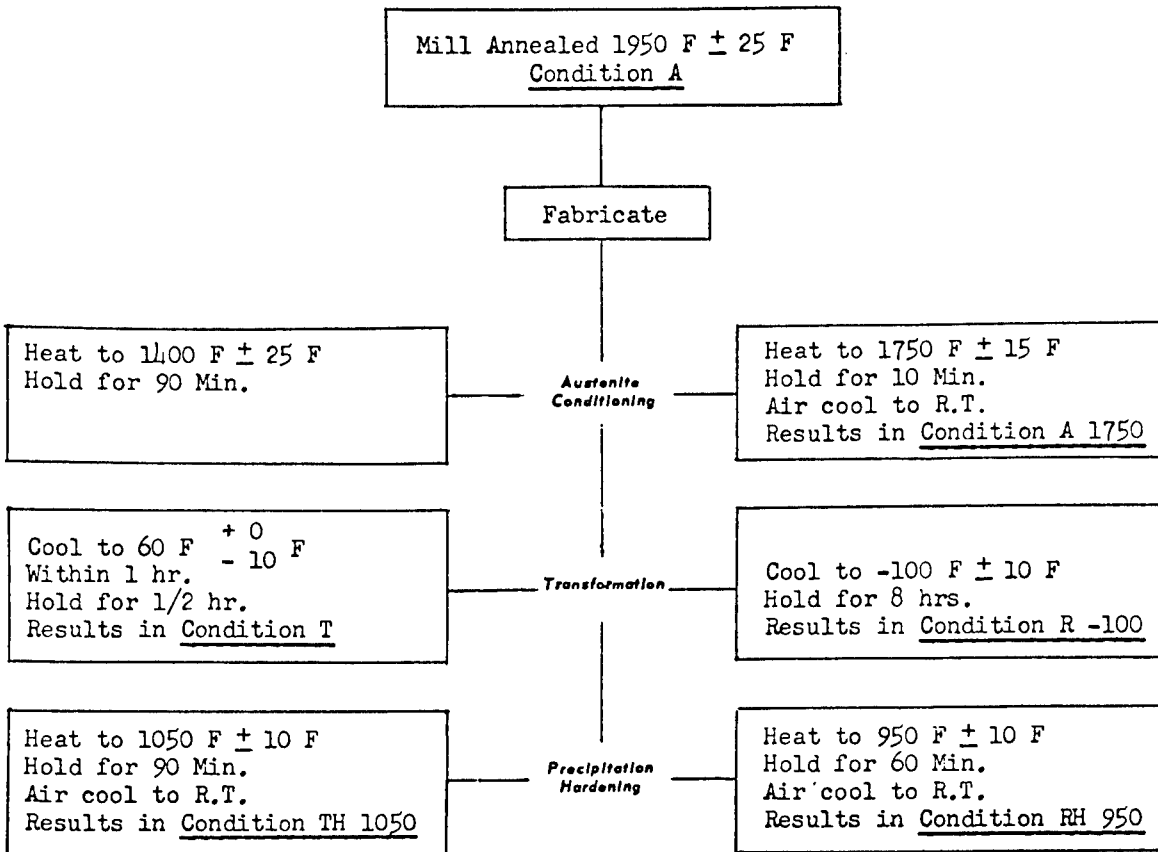

Condition C material may be heat treated in the following manner:

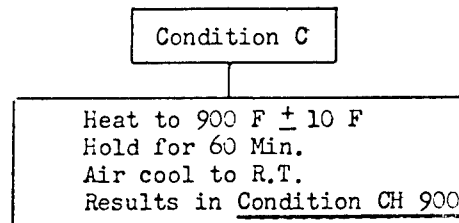

7.4.4 PH 15-7 Mo (Armco Steel Corp.)7.4.4.1 Condition as Supplied by Mill

Same as for 17-7 PH, see par. 7.4.3.1.

7.4.4.2 Heat Treatment by User

Same as for 17-7 PH, see par. 7.4.3.2.

7.4.5 AM-350 and AM-355 (Allegheny-Ludlum Steel Corp.)7.4.5.1 Summary of Conditions Vs. Heat Treatments

Grade	Condition	Heat Treatment	Purpose
AM-350	L	Solution treated at 1710 F $\pm$ 25°, air cooled or water quenched	Preparation for Hardening
	H*	Solution treated at 1850 to 1975 F, air cooled or water quenched	Formability
	SCT	Condition L plus 3 hours at -100 F plus 3 hours at 850 to 1000 F, air cooled	Hardening
	DA	Condition L or Condition H plus 3 hours at 1375 F $\pm$ 25°, air cooled to 80 F max, plus 3 hours at 850 F $\pm$ 25°, air cooled	Hardening
AM-355	L	Solution treated at 1710 F $\pm$ 25°, air cooled or water quenched	Preparation for Hardening
	H**	Solution treated at 1850 to 1900 F, air cooled or water quenched	Formability
	SCT	Condition L plus 3 hours at -100 F, plus 3 hours at 850 to 1000 F, air cooled	Hardening
	DA	Condition L plus 3 hours at 1375 F $\pm$ 25°, air cooled to 80 F max plus 3 hours at 850 F $\pm$ 25°, air cooled	Hardening
	Equalized and overtempered**	1425 F $\pm$ 50°, air cooled to 80 F max plus 1050 F $\pm$ 50°, air cooled (best machinability)	Machining

\* Condition of sheet and strip supplied from the mill.

\*\* Conditions of bar and forging billets supplied from the mill.

7.4.5.2 Annealing

These steels are annealed by heating to 1700 to 1950°F. and cooling to room temperature fast enough to prevent the precipitation of chromium carbides. For sheet and strip, air cooling is sufficient. For heavier sections, oil or water quenching is recommended.

#### 7.4.5.2

AM-350 and AM-355 are annealed either:

- a. To prepare the steel for maximum response to subsequent hardening or
- b. To impart maximum ductility to sheet and strip for fabricating operations.

AM-350 and AM-355 are annealed at  $1710^{\circ}\text{F.} \pm 25^{\circ}\text{F.}$  to prepare the steels for maximum response to subsequent hardening. After annealing at this temperature, the austenite is unstable enough to ensure maximum response to hardening by either of the two heat treating methods to be described later. This annealed state is designated as Condition L. Allegheny Ludlum does not normally supply AM-350 and AM-355 in Condition L because of possible hardening in transit or storage.

For maximum ductility, heat AM-350 to between  $1850$  and  $1950^{\circ}\text{F.}$ ; AM-355 sheet and strip to between  $1850$  and  $1900^{\circ}\text{F.}$  The austenite achieves greater room temperature stability due to the solution of carbides at these annealing temperatures. The precipitation-hardening steels have their best forming properties in this annealed state which is designated as Condition H. The H treatment is also used as an intermediate anneal in fabricating operations. Sheet and strip is normally shipped in Condition H

Annealing AM-355 over  $1900^{\circ}\text{F.}$  stabilizes the austenite so that full hardening does not occur upon subsequent Condition L annealing plus hardening cycles. Because of this, the maximum annealing temperature recommended for AM-355 is  $1875^{\circ}\text{F.} \pm 25^{\circ}\text{F.}$

Material which has been given this high temperature anneal must be subsequently reannealed at  $1710^{\circ}\text{F.} \pm 25^{\circ}\text{F.}$  for 90 minutes per inch of thickness or at least 4 minutes for thin gages. This ensures maximum response to the SCT hardening heat treatments.

Surfaces must be completely free from oil or other contaminants prior to annealing; and heat treating atmospheres must not carburize, decarburize or nitride, particularly in thin sections.

AM-355 castings are homogenized at  $2000^{\circ}\text{F.}$  followed by air cooling. This treatment eliminates or reduces coring to a minimum. If a controlled atmosphere is used, this treatment can be combined with a decarburizing treatment which may be necessary to remove excess surface carbon picked up from shell mold materials. Castings must also be given a conditioning anneal at  $1750^{\circ}\text{F.} \pm 25^{\circ}\text{F.}$  followed by water or oil quenching to ensure response to later heat treatment.

### 7.4.5.3 Hardening

AM-350 and AM-355 can be hardened by using either of the following two methods:

#### 1. Hardening by Sub-zero Cooling and Tempering (SCT)

Because the  $M_s$  temperature normally (after  $1710^\circ\text{F.} + 25^\circ\text{F.}$  annealing treatment) is slightly above room temperature, AM-350 and AM-355 can be completely hardened only by cooling to below room temperature. A minimum of 3 hours at  $-100^\circ\text{F.}$  ensures maximum austenite to martensite transformation.

For the best combination of strength and ductility, the primary martensitic structure must be tempered. The highest strength consistent with good ductility is obtained by tempering at  $850^\circ\text{F.}$  for a minimum of 3 hours. Higher tempering temperatures, up to  $1000^\circ\text{F.}$ , may be used to raise the .2 percent offset yield strength, to increase the room temperature impact strength and ductility and to improve machinability of bars and forging billets.

If this method of hardening is used, it is necessary to precede it with an anneal at  $1710^\circ\text{F.} + 25^\circ\text{F.}$  for 90 minutes per inch of thickness in cases where the material was previously annealed at  $1850$  to  $1950^\circ\text{F.}$  If annealing is done above  $1710^\circ\text{F.}$ , one can expect a decrease in the level of strength obtained by subsequent hardening. If the annealing temperature reaches  $1900$  to  $1950^\circ\text{F.}$ , no response at all may be observed.

#### 2. Hardening by Double Aging (DA)

Another method of hardening AM-350 and AM-355 consists of a two-stage precipitation-hardening treatment. The first stage, employing a three-hour treatment at  $1350$  to  $1400^\circ\text{F.}$ , results in the precipitation of chromium carbides. This operation alters the composition of the austenite so that it transforms completely to martensite on cooling  $80^\circ\text{F.}$  maximum. Further increase in strength and hardness is obtained by a final aging treatment of two to three hours at  $825$  to  $875^\circ\text{F.}$  Air cooling is sufficient in both stages. Double aging of AM-355 must be preceded by a Condition L anneal, but this is not necessary for AM-350.

The properties of double-aged AM-350 are not usually affected by the prior annealing temperature, but a minor decrease in strength is observed when the annealing temperature prior to double aging is increased from  $1700$  to  $1950^\circ\text{F.}$

### 7.4.5.3 - 7.4.6.1

Hardening AM-350 and AM-355 causes an increase in volume. The designer must be aware of this dimensional growth of parts being heat treated and must allow for it. AM-350 initially in Condition L, grows approximately .004 in. per inch; AM-355, initially in equalized and overtempered condition, approximately .0015 in. per inch. Less growth is experienced with AM-355 because in the equalized and overtempered condition, it has already undergone a martensitic transformation.

#### 7.4.5.4 Equalizing and Overtempering

In the case of AM-355 bars and forging billets, inconsistencies in hardening response arising from high forging and process annealing temperatures can be minimized by employing an equalizing treatment of 3 to 4 hours at 1375 to 1475°F. and air cooling to 80°F. maximum prior to the re-solution treatment at 1710°F. and the SCT treatment. Machinability is improved by equalizing followed by an overtempering treatment for 3 hours at 1050°F. Unless otherwise specified, bars and forging billets are supplied from the mill in the equalized and overtempered condition.

#### 7.4.6 A-286 (Allegheny-Ludlum Steel Corp.)

##### 7.4.6.1 Hardening

The heat treatment consists of two parts--a solution treatment followed by an aging treatment.

First is the solution treatment which puts the alloy in its softest and most ductile condition. This is accomplished by cooling rapidly from the solution temperature. Oil or water quenching is recommended for heavy sections while thin sections, such as sheet, may be air cooled. The solution temperature may be 1800°F. or 1650°F. for one hour. In general, creep and rupture strengths increase and rupture ductility decreases with increasing solution temperature. The 1800°F. temperature provides a good combination of properties and is generally recommended, whereas the 1650°F. temperature is used when a higher notch rupture strength and slightly higher hardness are required.

Second is the aging or precipitation hardening treatment which develops its high strength and hardness, and consists of holding at 1325°F.  $\pm$  15°F. for 16 hours followed by air cooling. The hardness and related mechanical properties of A-286 are highly dependent upon the aging temperature and somewhat less so on the aging time. Typical changes in hardness with variations in aging temperature and time of bar material solution treated 1800°F.--1 hr.--oil quenched and then aged as follows:

## 7.4.6.1 - 7.4.7.2

<u>Aging Time (Hr.) at 1325°F.</u>	<u>Brinell Hardness</u>	
0	146	
2	274	
4	292	
8	297	
16	288	

<u>Aging for 16 Hours at Indicated Temperature</u>	<u>Brinell</u>	<u>Hardness</u>	<u>Rockwell</u>
1325	293		RC 31
1350	286		RC 30
1375	277		RC 29
1400	262		RC 26
1425	262		RC 26
1450	241		RC 22
1475	217		RB 96
1500	202		RB 93

7.4.7 17-10 P (Armco Steel Corp.)7.4.7.1 Condition as Supplied by Mill

Normally, this material is supplied in the solution-treated condition. However, it can also be supplied in the single and double aged conditions. The various conditions in which 17-10 P can be purchased are described below.

How Condition is Developed

- |                      |  |
|----------------------|--|
| 1. Solution Annealed | Solution treated at 2050°F.,<br>water quenched   |
| 2. Single Aged       | Solution treated plus 1300°F.<br>for 24 hours, water quenched  |
| 3. Double Aged       | Solution treated plus 1300°F.<br>for 12 hours, water quench, plus<br>1200°F. for 24 hours, water<br>quench |

7.4.7.2 Heat Treatment

Material received in the solution annealed condition from the mill has been solution treated as a final operation before shipment and may be immediately aged either by a single aging or double aging treatment. Single aging consists of heating to 1300°F. for 24 hours and water quenching. Double aging consists of heating to 1300°F. for 12 hours,

#### 7.4.7.2 - 7.4.8

water quenching, and then reheating to 1200°F. for 24 hours and water quenching. The double heat treatment increases the .2% yield strength by approximately 10%.

If the material has been hot worked or process annealed during fabrication, it is necessary that it be solution treated at 2050°F. for one-half hour and water quenched before aging. It is recommended that the stock be charged in a furnace no hotter than 1600°F. and raised at a rate of about 100 degrees Fahrenheit per hour to 2050°F. The material should be soaked at 2050°F. for 30 minutes.

Aging 17-10 results in a predictable dimensional change. This change is a contraction of .0003-.0004 in. per inch.

#### 7.4.8 HNM (The Crucible Steel Co. of America)

Hardening processes are similar to those indicated for 17-10 P above.

## 7.5 Ferritic - Austenitic Grade (Type 329)

### 7.5.1 Hardening

Type 329 stainless steel is generally manufactured in the forms of bar stock or welded heat exchanger tubing. The chemical composition range specified by Carpenter Steel Co. for Type 329 bar stock is: C - 0.20%, Cr - 23.00 - 28.00%, Ni - 2.50 - 5.00%, and Mo - 1.50 - 2.50%. The tubular product, known as Carpenter 7 Mo, has the following composition: C - 0.08% max., Cr - 26.0 - 28.5, Ni - 3.75 - 4.50%, and Mo - 1.35 - 1.65%.

This grade of stainless steel is not truly austenitic or ferritic. It contains a large amount of ferrite in an austenite matrix and has many characteristics of the ferritic grades. It is annealed by water quenching from 1750° - 1800°F.

Hardening is performed by heating to 1350°F, holding at that temperature for at least 12 hours and cooling slowly in the furnace. When so treated, the material will develop a hardness of approximately 40 to 45 Rockwell C or 375 to 425 Brinell. This treatment renders the steel quite brittle, having about the same toughness as a good grade of cast iron.

Although manufacturers of Type 329 refer on occasions to the material as being hardened by a precipitation hardening mechanism, it actually hardens because virtually the entire structure is converted to sigma phase.

## 8. TESTING AND INSPECTION

### 8.1 Non-Destructive Methods

#### 8.1.1 Radiographic Inspection

##### 8.1.1.1 General

Radiography, either by x-rays or gamma rays, consists of directing rays first to penetrate the object being inspected and then to fall on sensitive film. As the amount of penetration varies inversely with the thickness of the object, thinner sections, cracks, or voids allow more radiation to pass, causing the film to be darker in these areas. Because the rays travel essentially in straight lines, flaws, if present, may be located and evaluated from the film<sup>3</sup>.

##### 8.1.1.2 Applications

At Savannah River Plant, radiographic examination has been employed to determine the quality of field and shop welds in all important piping systems and has been used on numerous occasions for the determination of casting soundness, and in the examination of welds in purchased items such as welded pipe and welded fittings which were not radiographed by the manufacturer. The use of this method by suppliers has been specified for purchased items such as vessels, pipe, tubing, and castings. It has been widely used for weld inspection in field erected storage tanks.

A recent application of radiography for Savannah River Plant at a manufacturer's shop has been the inspection of longitudinal welds in stainless steel tubing for severely corrosive reboiler services. One in. dia. x 10 gauge welded tubing, even when inspected by radiography for 100% of the weld length has been found cheaper than seamless tubing.

Another application where radiographic inspection could be used is for the detection of areas where the wall thickness of a pipe, tube, or vessel has been thinned by grinding in fabrication or by corrosion or erosion in service.

Radiographic examination has also been used by a heat exchanger fabricator to determine the quality of tube to tube sheet welds of the type shown in Par. 6.1.4.1 Figure 1(p). Thulium 170 was used in this case.

### 8.1.1.3 Techniques

#### a. Gamma Ray Radiography of Welds in Pipe

Figure 1 shows methods commonly used for gamma ray radiographic examination of welds in pipe.<sup>1</sup>

Method A - Film inside, radiation source outside. This method could be used for any pipe size that is large enough to permit inserting the film. It could only be used for piping assemblies which are being fabricated since access to the inside of the pipe is necessary. Several exposures would be required to cover the entire weld. This technique would be most suitable for radiographing local areas in welds in large pipe. Because of the direction of curvature, uneven exposure would result if long films are used.

Method B - Film outside, radiation source inside This method is suitable when the pipe is sufficiently large that the distance between the radiation source and pipe wall is great enough to permit radiographs of adequate sharpness to be made. At Savannah River Plant, this method was used for pipe 6 in. i.p.s. and larger. An advantage of this method is that the entire weld can be radiographed with one exposure. The distance from source to weld is always the same giving uniform film density. A disadvantage is that the pipe must be open to permit insertion of the source of radiation, making it of limited value for evaluation of welds in piping systems after installation.

Method C - Film and radiation source outside - double image. This method was used at Savannah River Plant for pipe under 2 in. i.p.s. With this method, the radiation source is placed sufficiently far from the nearest point on the weld that both the portion of the weld nearest the radiation source and the portion of the weld nearest the film are shown with adequate definition. The portions of the weld at the sides of the pipe must be shown on another exposure taken at 90° to the original. The radiation source is so placed that the radiation passes through the weld at an angle, projecting the weld on the film as an ellipse. A disadvantage of this method is the length of time

### 8.1.1.3

required to make an exposure. An advantage is that both radiation source and film are on the outside of the outside of the pipe, making the method suitable for use on installed piping.

Methods D & E - Film and radiation source outside - single image. With these methods the radiation source is placed sufficiently close to the pipe that only that portion of the weld adjacent to the film is shown with sufficient definition to permit interpretation. These methods become useful where the pipe diameter is sufficiently large that the exposure time required for the double image method described as Method C above becomes prohibitive. Method D could be used for the smaller pipe sizes such as 2 in. i.p.s. where the source in direct contact as shown in Method E would be too close to the film to give good definition. It could also be used for 3 in. and 4 in. pipe. These sizes (3 in. and 4 in.) are, however, examined by Method E on occasions. Method E is best suited for sizes over about 3 in. to 4 in. and can be used up to sizes around 30 in. where the exposure time becomes prohibitive. Since both the radiation source and the film are on the outside of the pipe, these methods are suitable for use on installed piping systems.

Method F - The method shown in Figure 2 is now considered to be acceptable for the examination of full penetration fillet welds such as used for the attachment of nozzles to vessel walls. Since the wall thickness through which the radiation must pass to reach the film is not uniform, the double film technique is used. One piece of film of fast speed and one of slower speed are placed in the film holder. The exposure time is chosen so that on the slower speed film, the thinner portion of the weld is correctly exposed and on the fast film the thicker portion of the weld is correctly exposed. By observing both films, the entire weld can be examined.

Method G - Radiographic examination can be employed to determine the wall thickness of a pipe as shown in Figure 2. This method is of value to determine if low spots have occurred in service as the result of corrosion or erosion.

b. X-Ray Radiography of Welds in Pipe and Tubing in Multiple Lengths

Figure 3 shows a method that has been used successfully to radiograph welds in several lengths of pipe or tubing simultaneously. This method is widely used when small diameter tubes, such as heat exchanger tubes must be radiographed. The tubes are positioned on a rack above the x-ray machine, and a tube length of approximately 2 1/2 ft. is radiographed with each exposure, the tubes being moved lengthwise after each exposure to bring into the range of the machine the next portion of the length that has not been radiographed. By means of this multiple tube radiographing technique, the cost of x-raying the longitudinal welds in the tubing may be as low as approximately \$0.15-0.25 per ft. for 1 in. tubing. Large size film is used so that a portion of each of the tubes on the rack will be shown on each film.

c. X-Ray Radiography of Circumferential Butt Welds in Pipe

Figure 4a shows a method commonly used for the radiographic examination of circumferential butt welds in pipe. At Savannah River Plant, this method was used for pipe 6 in. i.p.s. and smaller. The x-ray machine head should be positioned sufficiently far from the pipe wall toward the machine that it will show on the film with the required definition and sensitivity. The x-ray machine head is so positioned that the radiation will pass through the weld at an angle, thereby projecting the image of the weld on the film as an ellipse. Two exposures 90° apart are required to produce an image representing the entire circumference of the weld that is suitable for interpretation. For pipe larger than 6 in., it may be necessary to move the x-ray machine head closer to the pipe so that only the portion of the weld adjacent to the film will show with sufficient clarity for interpretation.

d. X-Ray Radiography of Longitudinal Butt Welds in Pipe

When large diameter welded pipe is to be radiographed or smaller pipe in other than extremely large quantities, the method shown in Figure 4b is frequently used. This is slower than the technique for radiographing multiple lengths previously discussed, but requires no special racks and facilities for inverting the x-ray machine head.

#### 8.1.1.4

##### 8.1.1.4 Standard Specifications

Section VIII, Unfired Pressure Vessels, of the ASME Boiler and Pressure Vessel Code provides the most widely used rules covering the technique for radiographic examination of welded joints and rules for interpretation of radiographs. Par. 6.6 includes a summary of these ASME requirements.

Another specification frequently referred to is MIL-STD-271B (Ships), "Military Standard, Non-destructive Testing Requirements for Metals". This specification contains detailed information on radiographic techniques.

The following ASTM Specifications are available:

E142 - Controlling Quality of Radiographic Testing.

This specification covers the following subjects:

- Direction of Radiation
- Penetrameters
- Levels of Inspection
- Placement of Penetrameters
- Number of Penetrameters
- Location of Markers
- Identification of Radiographs
- Multiple Film Techniques
- Image Quality
- Source-Film Distance

E-71 - Industrial Radiographic Standards for Steel

Castings. This specification classifies castings according to wall thickness and intended use, and sets forth permissible defect levels for the different classes of castings.

E-69 - Tentative Reference Radiographs for Steel

Welds. This publication describes a set of reference radiographs which can be purchased for use as an aid in interpreting radiographs of steel welds.

E-94 - Radiographic Testing. This recommended

practice is intended as a guide for satisfactory radiographic testing.

This recommended practice, issued in 1952, is out of date on some subjects. Some of the subjects covered are listed below:

Radiation Sources  
 Radiographic Equivalence Factors  
 Film  
 Screens  
 Radiographic Contrast  
 Focus-Film Distance  
 Exposure Charts and Calculators  
 Exposure Factors and Arrangement of Parts  
 Protection and Care of Unprocessed Films  
 Processing Films and Viewing Radiographs

E-52 - Tentative Industrial Radiographic Terminology for Use in Radiographic Inspection of Castings and Weldments

#### 8.1.1.5 Radiographic Terms<sup>3</sup>

- a. Energy - essentially determines penetration properties of the radiation. In x-ray work, energy is usually determined by the accelerating voltage (kilovolts) applied to the anode. In gamma ray work, energy (a characteristic of the source) is measured in electron volts (kilovolts). The energy of the gamma ray corresponds to the maximum energy or hardest x-ray generated by an x-ray machine at the same potential.
- b. Roentgen - the unit of radiation quantity, which is based on the ionizing effect of radiation on a given quantity of air at standard temperature and pressure.
- c. RHM - the Roentgen output per hour of one curie measured at one meter from the source of radiation.
- d. Curie - a measure of the amount of nuclear disintegration ( $3.7 \times 10^{10}$  per second) indicating the theoretical radiation output of an isotope. As the self absorption of different isotopes varies, the number of curies is only an approximate guide to the amount of radiation.
- e. Milliamperage - the anode current of an x-ray tube - indicates the quantity of radiation.

#### 8.1.1.5 - 8.1.1.6

- f. Half-life - a half-life is the period of time required for the curie strength of an isotope to decay to half its prior value.
- g. Half-thickness - the thickness of a material that reduces the incident radiation by a factor of two.
- h. Sensitivity - a measurement of the flaw detecting ability. It is the ratio expressed as a percentage of size of flaw discernable to the thickness of the material. For example, a sensitivity of 2% indicates that flaws as small as 0.06 in. in the direction of the radiation can be found in material 3 in. thick.
- i. Definition - the degree of clarity of a radiograph.
- j. Contrast - the difference in tone between the darkest and lightest portions of a radiograph.

#### 8.1.1.6 Radiation Sources

##### a. General

Radiographic inspections are conducted with both x-rays and gamma rays. The choice of one type of radiation over the other depends on the sensitivity and sharpness of detail requirements, the thickness of the part, location of the item to be inspected, and equipment available.

In general, greater sharpness of detail and better contrast are available from x-rays than from gamma ray sources. Where very good definition is required, such as to detect fine cracks in thin material, an x-ray machine is essential. Where the stainless steel section thickness is not too great for portable x-ray machines, the x-ray radiographic method should be given first consideration even for inspection of field welds. For field inspection of weldments in heavy plate, say over about 2 to 2 1/2 in. in thickness, the use of an isotope is almost a necessity since truly portable x-ray machines of sufficient capacity are not available. For shop fabrication, involving vessels of very heavy plate, say over 3 in. in thickness, for severe service conditions, fabricators should be chosen who possess high voltage x-ray equipment. Such equipment is available to

cover the x-ray energy range of 1 to 24 Mev. This range routinely would cover a thickness range from 1/2 to 13 in. This is large, very expensive equipment and is found primarily in large shops where heavy plate fabrication is performed.

#### b. X-Ray Machines

X-rays are produced when electrons, traveling at high speed, collide with matter. In the usual type of x-ray tube, an incandescent filament supplies the electrons and thus forms the cathode, or negative electrode of the tube. A high voltage applied to the tube drives the electrons to the anode or target. The sudden stopping of these rapidly moving electrons in the surface of the target results in the generation of x-rays.

Different voltages are applied to the x-ray tube to meet the demands of various classes of radiographic work. The higher the voltage, the greater the speed of the electrons striking the focal spot. The result is a decrease in wave length of the x-rays emitted and an increase in their penetrating power and intensity. The higher voltage x-rays are used for the penetration of thicker and heavier materials.

Table 1 lists typical x-ray machines according to maximum voltage and gives applications and approximate practical thickness limits. Portable machines are generally 150 or 260 kv. These machines, unless auxiliary cooling is provided, are not designed for continuous service over long periods of time, but are suitable for many field inspection applications.

Figure 5 gives typical exposure times for typical, normal, and high voltage x-ray machines for various steel thicknesses. Some gamma ray exposure times are also shown. The gamma ray exposure times can be shortened somewhat by the use of larger sources and by shorter source to film distances.

#### c. Gamma Ray Sources<sup>3</sup>

The two most common sources used for isotope radiographs are Iridium 192 and Cobalt 60. Other sources

#### 8.1.1.6

including radium, Thulium 170, Cesium 137, and Sodium 24 are also used. Table 2 compares the properties of several gamma ray sources. Table 3 compares the thickness ranges covered by the various gamma ray sources with those of x-ray machines of various sizes.

Originally, radium was used for industrial radiography; however, its high cost and its low specific activity (resulting in large sources with the attending difficulty of poor definition) have resulted in the change to isotopes as they became available.

Cobalt 60 has become widely used because of its high specific activity, its low cost, and its wide range of applications.

The radiation from Iridium 192 being softer (of longer wavelength) than that from Cobalt 60 makes it more useful for thinner sections. Furthermore, its extremely high specific activity makes possible very small but powerful sources. Theoretically, the short half-life (75 days) of Iridium 192 is a disadvantage, but modern methods of source replacement have made Iridium 192 an extremely useful isotope. Figure 6 compares the physical dimensions of typical Cobalt 60, Iridium 192, and Cesium 137 sources of equal size (in curies).

Thulium 170 has attractive theoretical advantages for very thin sections, but obtaining this isotope in a sufficiently pure state to obtain the desired qualities is somewhat difficult.

Cesium 137 has radiation characteristics intermediate between Iridium 192 and Cobalt 60 with a long (27 years) half-life. Two disadvantages hinder its wider use. Its specific activity is low, resulting in long exposure times and physically larger sources, decreasing the definition of the radiograph. Secondly, Cesium 137 sources are composed of compacted Cesium chloride and thus the possibility of leakage of this material is much greater than with other sources. For this reason, the AEC requires that Cesium sources be inspected at least every six months, adding somewhat to the cost of using Cesium 137. Neither Iridium 192 or Cobalt 60 sources require these special inspection procedures.

Sodium 24 has been used where extremely powerful sources are required but its very short half-life of 14 hours prevents its use except for special applications.

The problem of choosing a source involves consideration of the type and thickness of the material to be inspected, the exposure time which can be tolerated, the frequency of the exposures, cost, desired sensitivity, and geometrical constraints imposed on the exposure. In isotope radiography, the quality of the radiation depends on the isotope chosen. The quantity of this energy per unit time at a given distance (intensity) is dependent on the curie size of the source. For example, Cobalt 60 has nearly twice the average energy of Cesium 137 and over three times that of Iridium 192. One curie of Cobalt has an output of 1.350 Roentgen per hour per meter while a 10 curie source would have ten times this amount.

Figure 7 gives typical exposure times for various thicknesses of steel for Cobalt 60, Iridium 192, and Cesium 137. In many cases, the source to film distance would be shorter than the 36 in. value used in Figure 7, thereby decreasing the exposure time.

Some recent work reported by Atomic Energy of Canada gives the following recommended thickness range for five isotopes when radiographing steel<sup>5</sup>:

<u>Isotope</u>	<u>Thickness Range, In.</u>
Thulium 170	1/8 - 1
Iridium 192	1/4 - 2 1/2
Cesium 137	1/2 - 3 1/2
Cobalt 60	3/4 - 8
Thorium 228	2 - 8+

#### 8.1.1.7 Comparison of X-Ray and Gamma Ray Inspection

Generally speaking, an x-ray machine is more flexible than an isotope as a radiation source, since its KV and Milliamps (MA) normally can be varied over certain ranges. For example, a 150 to 250 kv. machine can cover, by proper choice of KV and MA, a thickness range in steel or bronze of 1/16 in. to 2 in. as well as 1 in. to 8 in. in aluminum or magnesium. The isotope most nearly approximating this is Iridium 192 which cannot cover the thinner sections but is good on thicker sections<sup>3</sup>.

### 8.1.1.7

Ideally, in order to obtain maximum definition and contrast, an x-ray machine of the proper KV rating would be used for all applications requiring radiographic examination. In shop work there is no difficulty in obtaining x-ray radiographic inspection of welds where the plate thickness will permit the use of x-ray machines up to 250 KV. Several large fabricators of heavy plate have high voltage equipment with outputs greater than 1,000 KV which permit the radiographic examination of almost any thickness of material that would be used in weldments.

In radiography of welds and equipment under field conditions, there are many problems in the use of x-ray machines:

- a. Truly portable machines have an output limit of around 250 KV. This limits the metal thickness which can be inspected to about 2 in. of steel. *300 KV P  
1957*
- b. An electrical power source is required.
- c. Some cooling mechanism is required.
- d. The x-ray machine head, even in portable machines, is heavy and difficult to position - especially when radiographing welds in installed piping in a building.
- e. The relatively large size of the x-ray machine head makes it impossible to perform radiographic inspections in confined locations.

In addition, the initial cost of an x-ray machine is high and there is maintenance cost, including periodic tube replacement.

Isotopes on the other hand require no power source or cooling; are contained in a smaller source holder which is highly portable and relatively easy to position, small enough in size to permit positioning at almost any conceivable location; and require no maintenance.

The main advantages of isotope radiography are its low cost, and portability. These characteristics extend the applications to include many items which due to their size, shape, or physical location are impossible to radiograph with the usual x-ray techniques. The lower cost of isotope radiography makes the use of radiography practical for many additional applications<sup>3</sup>.

8.1.1.8 Sensitivity

The sensitivity of the radiographic process is the measure of the success in detecting small defects. It is customary to express sensitivity as the percent ratio of the thickness of the smallest detectable defect to the thickness of the base material. For example, a technique is said to have a sensitivity of 2% in which the presence of a void 0.020 in. deep can be seen in a specimen 1 in. thick.

In general, sensitivity is dependent upon the entire radiographic process and, in particular, on contrast and definition. The table below shows the factors which directly influence definition and contrast, and indirectly influence sensitivity:

Factors Affecting Sensitivity

<u>Definition</u>	<u>Contrast</u>
1. Focal spot size	1. Kilovoltage
2. Target to film distance	2. Screens
3. Object to film distance	3. Scattered radiation
4. Type of film	4. Development time
5. Screens	5. Density
6. Screen-film contact	6. Type of film

8.1.1.9 Types of Film

Various types of film are available which differ in speed, contrast, and graininess. The success of a radiographic examination depends to a large extent on the type of film used. In general, higher contrast, fine grain films are slower but produce better quality radiographic images.

The characteristics of several brands of radiographic film are listed in Table 4.

In the radiographic work conducted during the construction of Savannah River Plant, the film used for radiographic examination was of the type described in Table 4 as "medium speed, high contrast, fine grain". This film was used with lead screens. No use of intensifying screens was permitted.

Where the high contrast, fine grain type does not give sufficient definition, film representing one of the very fine grain, high or very high contrast types should be used.

8.1.1.10

8.1.1.10 Screens

a. Lead Foil Screens

Lead foil in intimate contact with both sides of the film during exposure improves the quality of the radiograph by reducing the effect of scattered radiation. Lead foil screens permit a reduction in exposure time with metal thicker than about 0.10 in. of steel and kilovoltages higher than about 120. In all such exposures, the use of lead foil screens is recommended because they improve the quality of the radiograph. With x-rays below 500 KVP, lead screen thicknesses are 0.005 in. in front of the film and 0.010 in. behind.

b. Fluorescent Screens

Fluorescent or intensifying screens consist of a powdered fluorescent material in a suitable binder coated on a cardboard or plastic support. The film is clamped firmly between a pair of these screens during exposure. The radiation causes the material to fluoresce, thereby exposing the film by visible light in addition to the radiation from the source. Fluorescent screens permit great reduction in exposure time with some loss of definition. The poorer definition is caused by the spreading of the visible light emitted from the screens. Fluorescent screens should be used only when the exposure necessary without them would be prohibitive, and the sensitivity that can be achieved with them is acceptable for the application.

SOURCES OF INFORMATION

1. International Institute of Welding, "Recommended Practice for Radiographic Inspection of Fusion - Welded Joints - Circumferential Butt Joints in Steel Pipes up to 2 in. Wall Thickness", British Welding Journal, June 1960.
2. Bulletin from Technical Operations, Inc.
3. Bulletin, "Industrial Radiography", Curtiss-Wright Corporation, Princeton Division, Princeton, New Jersey.
4. "Radiography in Modern Industry", Second Edition, Eastman Kodak Company, X-Ray Division, Rochester, New York.
5. Anderson, M. B., "Radiographic Sensitivity Data for the Isotopes Cobalt 60, Iridium 192, Cesium 137, Thulium 170, and Thorium 228", Nondestructive Testing, November-December 1959.
6. Welding Engineer's Engineering Data Sheet No. 238, Welding Engineer, June 1960.

Par. 8.1.1 Fig. 1

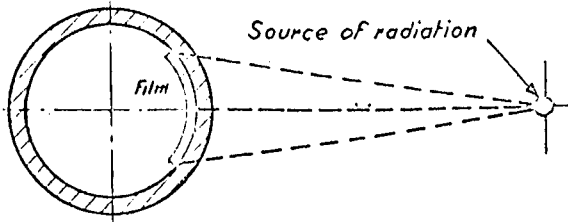

Method A — Film inside, radiation source outside

Figure 1  
Techniques for  
Gamma Ray Radiography  
of Pipe Welds

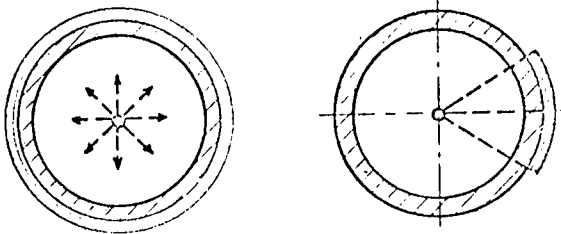

Method B — Film outside, radiation source inside

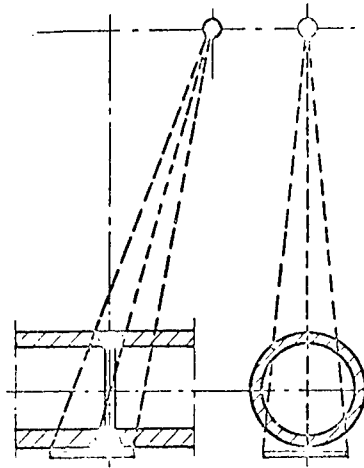

Method C — Film and radiation source outside. (Double image)

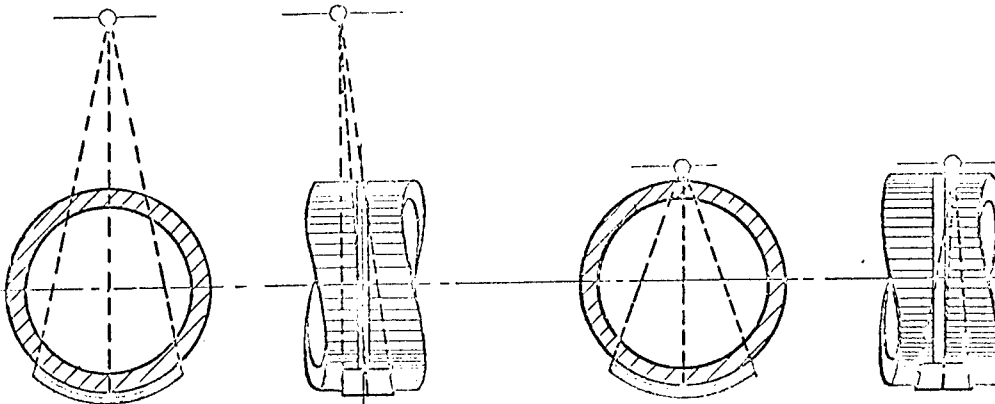

Method D

— Film and radiation source outside. (Single image)

Method E

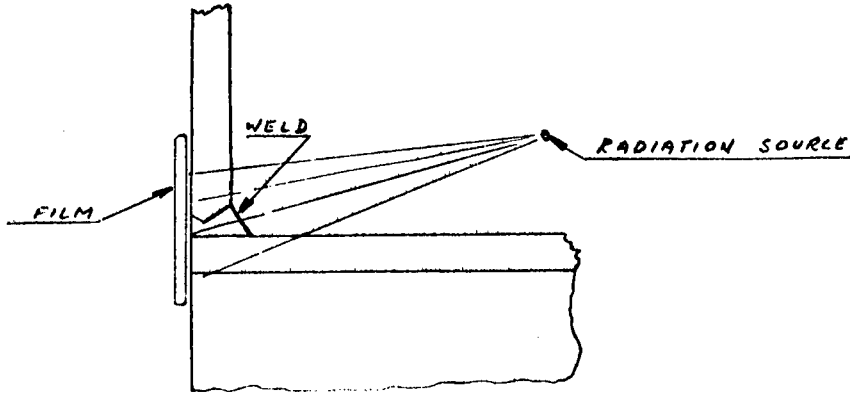

Method F - Method for Examination of Full Penetration Fillet Welds Using the Double Film Technique

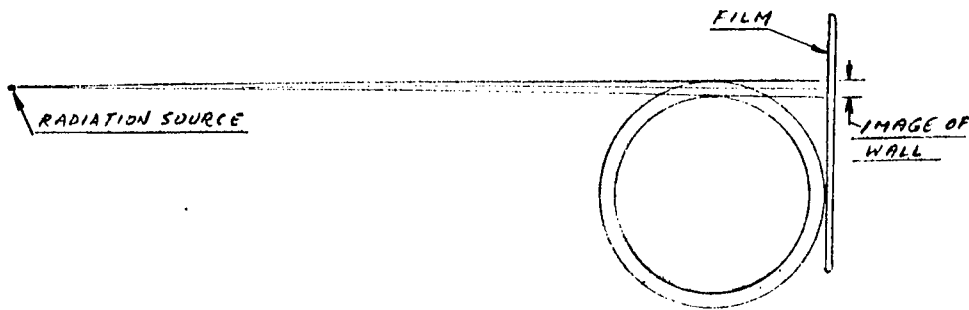

Method G - Method for Determining Pipe Wall Thickness

Par. 8.1.1 Fig. 3

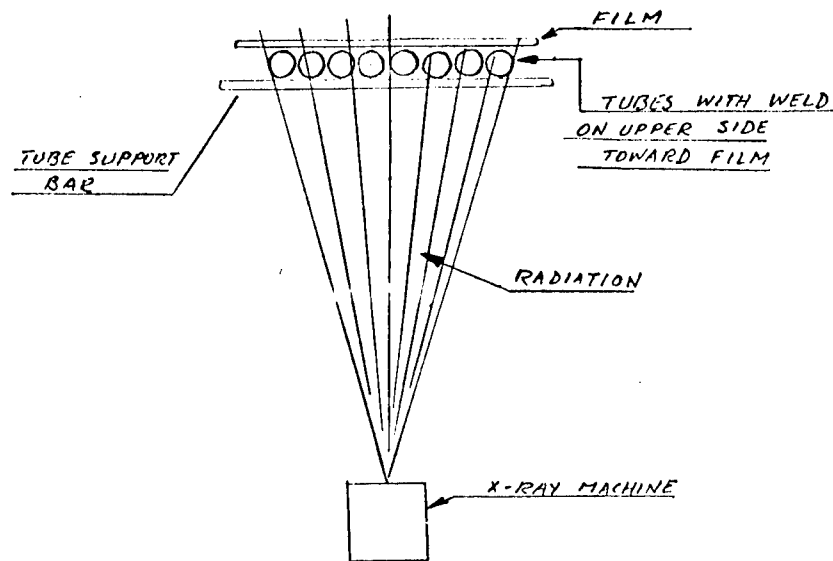
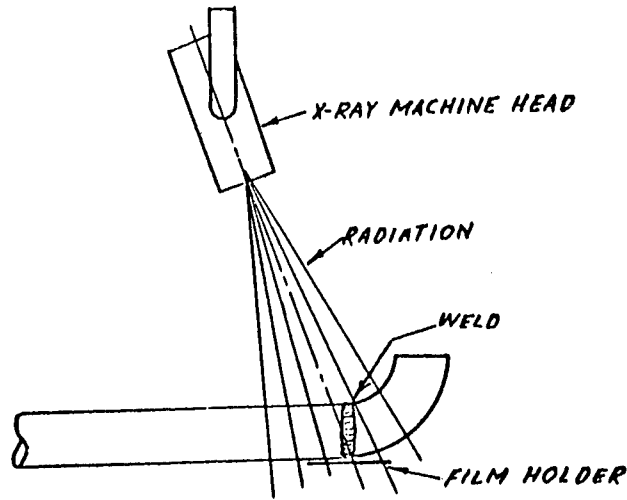
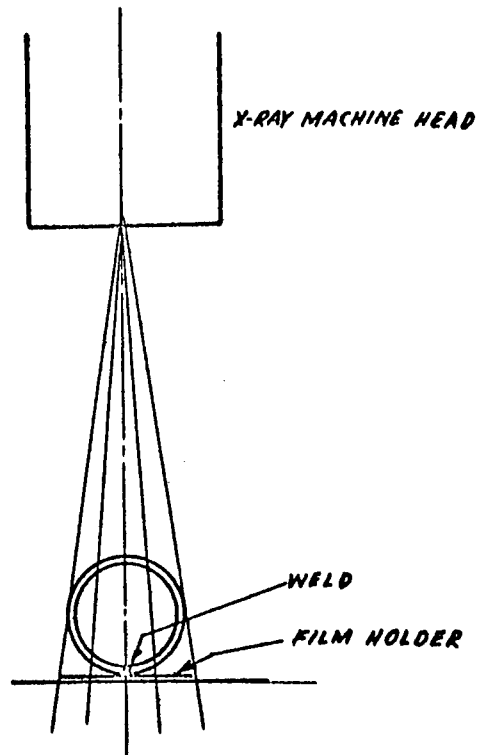

Figure 3 - Method of Radiographing Longitudinal Welds for Multiple Lengths of Heat Exchanger Tubing or Small Diameter Pipe



a. X-Ray Radiographic Technique for Circumferential Welds in Pipe



b. X-Ray Radiographic Technique for Longitudinal Welds in Pipe

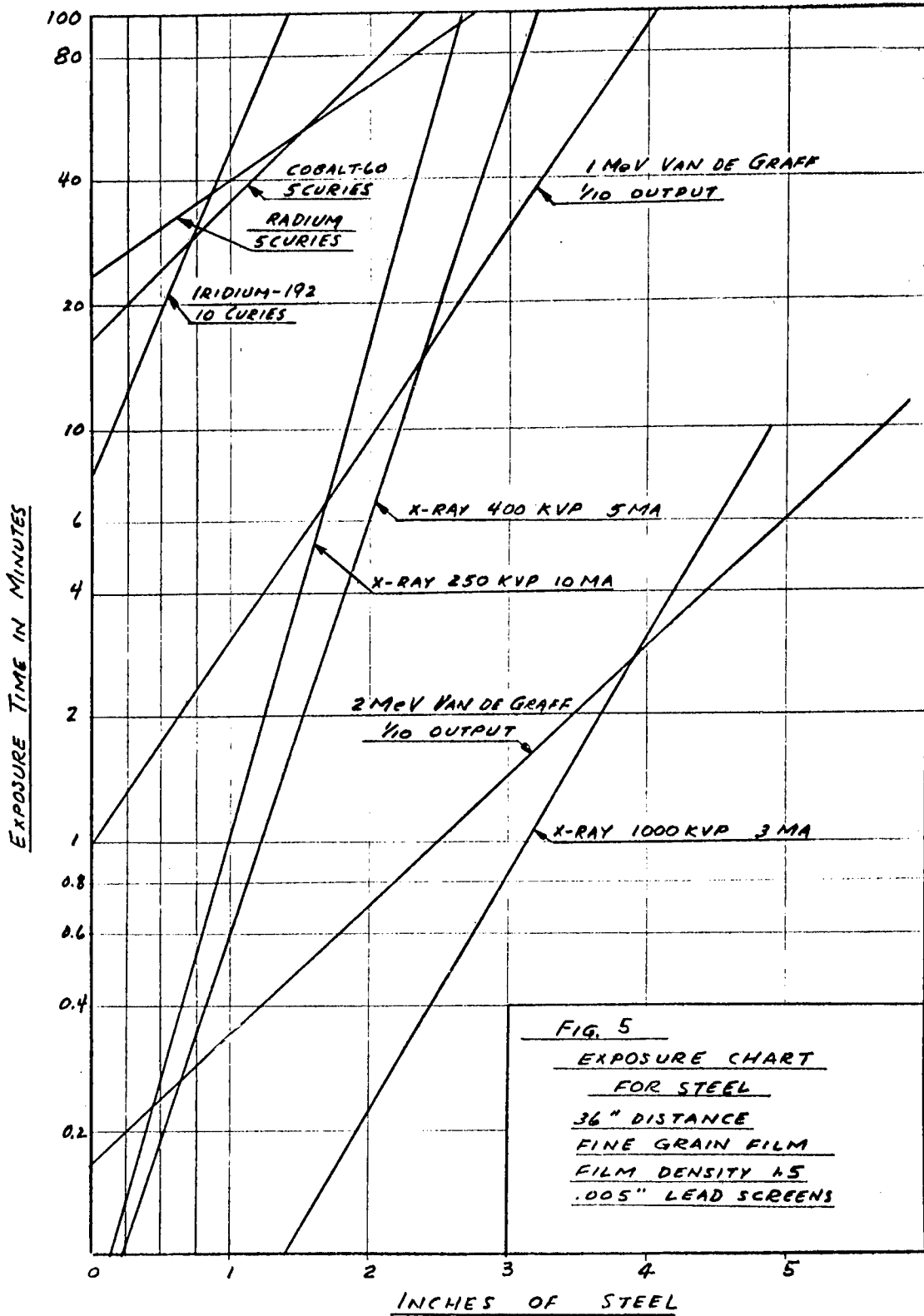

### ***Physical Size of Isotope Sources<sup>2</sup>***

The physical dimensions of the active material in an isotope source are important. This size, identified as the "focal point," is responsible for radiographic definition, or the sharpness of image outline on the x-ray film. The smaller the focal point, the more clearly-defined will be the image. In selecting a source size; the practical definition requirements resulting from small size are balanced against speed requirements resulting from large sources.

Source size is a function of specific activity, which is continually improving as our nuclear reactors are devoted more and more to industrial requirements. Typical source sizes available today are shown in full scale below (cross sections of right cylinders).

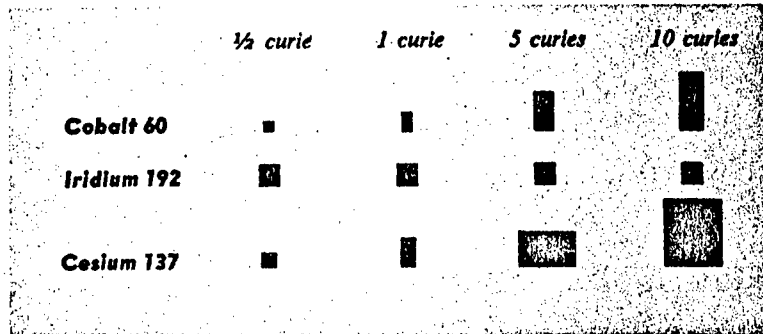

Fig. 6 - Comparison of Physical Dimensions of Typical Gamma Ray Sources of Equal Size (in Curies).

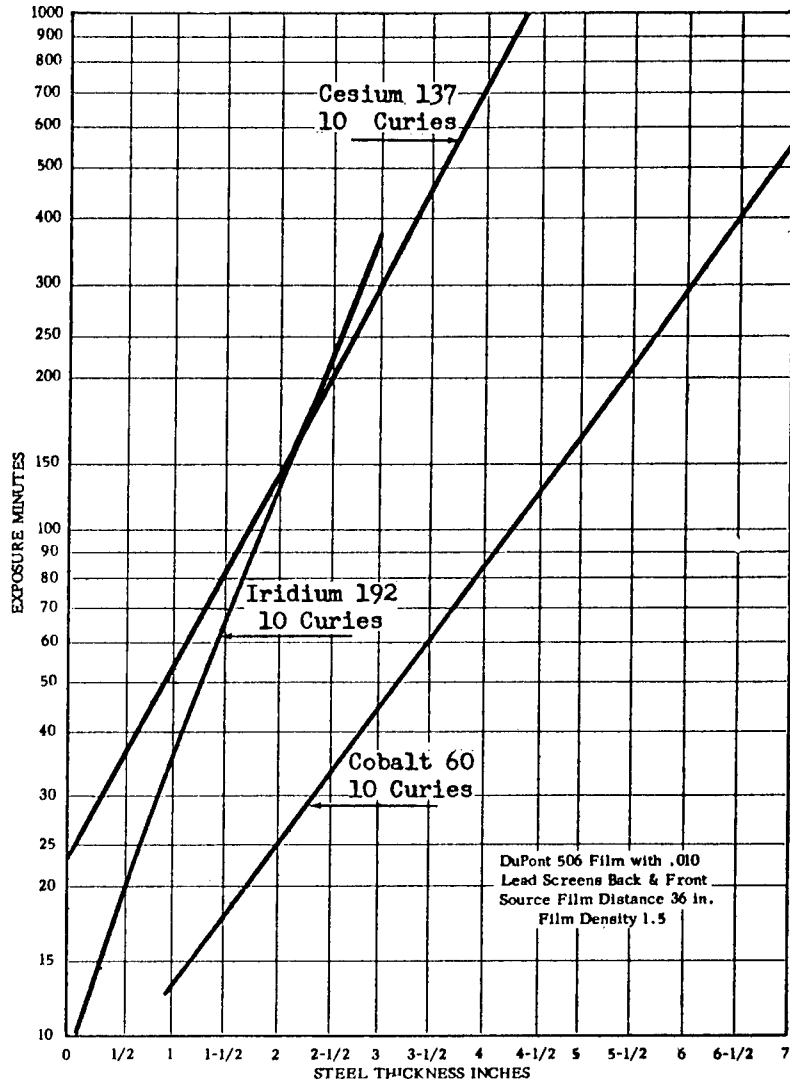

Fig. 7 - Exposure Chart for Gamma Ray Radiography of Steel

TABLE 1 TYPICAL X-RAY MACHINES AND APPLICATIONS

Max. Voltage (kv.-Peak)	Screens	Applications and Approximate Practical Thickness Limits
50	None	Extremely thin metallic sections, wood, plastics, biological specimens, etc.
150	None or Lead Foil	Light alloys; 5 in. alu- minum or equiv.; 1 in. steel or equiv.
	Fluorescent	1-1/2 in. steel or equiv.
250	Lead Foil	2 in. steel or equiv.
	Fluorescent	3 in. steel or equiv.
400	Lead Foil	3 in. steel or equiv.
	Fluorescent	4 in. steel or equiv.
1000	Lead Foil	5 in. steel or equiv.
	Fluorescent	8 in. steel or equiv.
2000	Lead Foil	8 in. steel or equiv.
15-24 (Mev)	Lead Foil	16 in. steel or equiv.
	Fluorescent	20 in. steel or equiv.

Par. 8.1.1 Table 2

	Average Energy (Kv)	Half-Life	Specific Activity (curies/ gram)	Output per curie mr/hr/meter	Average Half-Thickness (inches)		
					Concrete	Steel	Lead
Thulium 170	85 (much internal conversion)	127 days	5-50	5-12	—	—	—
Iridium 192	350	75 days	10-200	560	2.2	0.5	0.14
Cesium 137	660	27 years	5	350	2.6	0.8	0.25
Cobalt 60	1200	5.3 years	2-40	1350	3.4	1.0	0.49
Radium	200-2200	1690 years	1	1000	—	—	—
Sodium 24	2700	14 hours	5	2000	—	—	—

Table 2 - Sources for Gamma-Ray Radiography

Par. 8.1.1 Table 3

Thickness	Light Alloys (Aluminum and Magnesium)	Steel and Bronzes (Carbon and Stainless Steel) (Monel and Bronze)
Under 1/4"	30-150 KV X-ray Thulium 170	30-150 KV X-ray 60-250 KV X-ray Thulium 170
1/4" - 1/2"	30-150 KV X-ray Thulium 170	30-150 KV X-ray(PB)** 60-250 KV X-ray(PB)**
1/2" - 3/4"	30-150 KV X-ray 60-250 KV X-ray Thulium 170	60-250 KV X-ray(PB)** Iridium 192(PB)** Cesium 137(PB)**
3/4" - 1"	30-150 KV X-ray 60-250 KV X-ray Thulium 170	60-250 KV X-ray(PB)** Iridium 192(PB)** Cesium 137(PB)**
1" - 2 1/2"	30-150 KV X-ray 60-250 KV X-ray	60-250 KV X-ray(PB)** Iridium 192(PB)** Cesium 137(PB)** Cobalt 60(PB)**
2 1/2" - 3 1/2"	60-250 KV X-ray	60-250 KV X-ray(CTS)*(PB)** 1000 KV X-ray(PB)** Cesium 137(PB)** Cobalt 60(PB)**
3 1/2" - 5"	60-250 KV X-ray Cobalt 60(PB)**	1000 KV X-ray(PB)** Cobalt 60(PB)**
5" - 6"	60-250 KV X-ray(PB)** 1000 KV X-ray(PB)** Cobalt 60(PB)**	1000 KV X-ray(PB)** Cobalt 60(PB)**
6" - 8"	60-250 KV X-ray(PB)** 1000 KV X-ray(PB)** Cobalt 60(PB)**	2000 KV X-ray(PB)**

\*CTS - Using Calcium Tungstate Screens

\*\*PB - Using Lead Screens

(From Industry & Welding Magazine†, March 1958)

† Name changed to WELDING DESIGN & FABRICATION Magazine

Table 3 - Comparison of Thickness Ranges Covered by the Various Gamma Ray Sources With Those of X-ray Machines

# Comparison chart of X-ray film<sup>6</sup>

Film type	Trade name	Recommended applications
Fast speed High contrast Fine grain	AnSCO Superay 'A' Gevaert Structrix D10 Ilford Industrial B	Thin sections or low-density materials, such as aluminum and magnesium alloys. Heavy sections or complete castings with lead screens at high voltages. Light alloy and steel castings and welds. Medium to fairly great thicknesses of heavy metal.
Fast speed High contrast Very fine grain	Gevaert Structrix D7	Medium and fairly great thicknesses of light metal or thin and medium thick objects of heavy metal. Also thick objects of heavy metals at high voltages.
Fast speed High contrast Extra fine grain	Du Pont Type 510	Thin sections of low-density materials at low voltages and steel up to 3-in. thick at high voltages.
Fast speed Medium contrast Fine grain	AnSCO Superay 'D' Kodak Type F	Wide range of thicknesses with intensifying screen for heavy metals at low voltages. Steel, brass, etc. with limited kilovoltage machines.
Very fast speed High contrast Medium grain	AnSCO Superay 'C' Gevaert Structrix S Ilford Industrial G	Especially suited to gamma radiography or production line work. Thick objects of heavy metal (bronze and steel castings) at low voltages.
Very fast speed Medium contrast Medium grain	Ilford Industrial A Kodak Type KK	Heavy castings in steel, bronze, etc., and for rough examination of steel welds. Also castings and assemblies having a wide range of thickness or density.
Medium speed High contrast Fine grain	Du Pont Type 506 Ilford Industrial CX Kodak Type AA	Light metal castings requiring fine detail and critical examination of steel welds up to 1½-in. thick. Light metals at lower voltages and heavier steel parts at higher voltages.
Medium speed Extra high contrast Extra fine grain	Gevaert Structrix D4	Thin to medium thick objects of light metal at normal voltages, and thick objects of light metal and thin objects of heavy metal at high voltages.
Moderate speed High contrast Fine grain	Ilford Industrial C	Light metal castings requiring fine detail and critical examination of steel up to 1½-in. thick.
Moderate speed Extra high contrast Extra fine grain	Gevaert Structrix D2 Ilford Industrial F	Thin or medium thick sections of light metal at low or medium voltages when fine detail is required; allows use of higher-than-usual voltages without loss of contrast.
Moderate speed Very high contrast Extra fine grain	AnSCO Superay 'B' Kodak Type M	Light metals requiring highest quality definition; also for high voltage gamma and X-radiation.

## 8.1.2 Ultrasonic Testing

### 8.1.2.1 General

Ultrasonic testing is a nondestructive method for measuring the thickness of, and detecting defects within, various metallic materials of construction. Instruments employing pulse-echo and resonance principles are used for ultrasonic inspection. Resonance techniques are employed primarily for measuring the wall thickness of piping and equipment. Pulse-echo techniques are also used for thickness measuring, but find widest application for flaw detection.

### 8.1.2.2. Theory of Operation

#### a. Pulse-Echo Testing

The circuitry of a typical pulse-echo test instrument is shown in Figure 1<sup>1</sup>. The instrument generates high frequency (0.5-10.0 megacycles per second) sound waves electronically, and transmits them through a nonmetallic piezo-electric crystal (e.g. quartz, barium titanate, or lithium sulfate) mounted in a search unit which is coupled with the part being tested. The crystal vibrates while sending out the initial pulse, then stops to receive the reflection of that pulse from a defect and/or the opposite side of the part under test. The portion of the initial pulse which is reflected back to the crystal is converted into electrical energy which is amplified and transposed on the screen of a cathode ray tube, Figure 2<sup>1</sup>. This amplified, reflected wave is timed so that the reflection appears on the screen as a vertical indication ("pip") to the right of the indication set up by the initial pulse. The distance between the initial pulse and each "pip" is an exact measure of the time that the wave has traveled through the material being tested.

The above cycle of pulse transmitting and receiving is repeated at regular intervals so that an essentially continuous indication is obtained. For a given ultrasonic velocity in a material, the sweep can be calibrated directly in terms of distance or depth. Square wave markers as shown on the sketch of the cathode ray tube screen on Figure 2 can be superimposed on the horizontal sweep line. The steps can be changed to represent any desired unit of length. The "pip" amplitudes represent the intensities of transmitted or reflected pulses. These

### 8.1.2.2 - 8.1.2.3

may be related to flaw size, wave attenuation, wave spread and other factors.

#### b. Resonant Frequency Testing

Resonance instruments such as the Branson "Audigage" are similar in characteristics to pulse-echo units in that piezo-electric crystals are used to transmit and receive high frequency sound waves, through direct contact of the crystal with the test surface. However, the main difference is that the test frequency is varied between upper and lower limits (e.g., between 2 and 4 megacycles per second) instead of remaining constant. These instruments are designed to indicate the frequency at which an exact number of half wave lengths fit into the thickness dimension of the material under test<sup>2</sup>. A single half wave fitting exactly in the thickness dimension is considered the fundamental resonant frequency; multiples of this frequency are called harmonics. Use of the higher harmonic resonances is made by measuring the frequency difference between successive harmonics. This frequency interval is equal to the fundamental frequency. If the harmonic number is known, or determined, the thickness may be calculated from the following formula:

$$T = \frac{K(n)}{fn}$$

where T = thickness in inches, f = frequency in megacycles per second, n = harmonic number, and K is a constant for the particular material under test, equivalent to one-half of the sound velocity through the material in inches per second x 10<sup>-6</sup>.

#### 8.1.2.3. Ultrasonic Test Methods

There are four basic methods for ultrasonic testing of materials using pulse-echo principles to detect flaws. These methods, illustrated in Figure 3<sup>3</sup>, include:

- a. Straight Beam Searching - makes use of longitudinal waves perpendicular to the test surface to detect defects in materials, and measure wall thickness.
- b. Angle Beam Searching - makes use of shear waves introduced at an angle to test surface. Locates defects which might be undetected by straight beam searching.
- c. Surface Wave Searching - makes use of shear waves traveling along and just below the test surface for locating surface defects.

d. Immersion Searching - makes use of both shear waves and longitudinal waves to inspect materials totally immersed in a liquid; particularly applicable to irregularly-shaped objects.

The first three methods require intimate contact between the search unit and the surface under test. Generally, a thin film of a suitable couplant, such as grease, oil or glycerine, is used between the search unit and the test surface for maximum sensitivity and minimum wave attenuation. In the fourth method, both the search unit and the test specimen are totally immersed in a suitable liquid couplant, such as water. The search unit is usually located several inches from the test specimen, and the sound waves are transmitted to, and received from, the specimen through the liquid.

A variation of straight beam searching, called through transmission searching, may be accomplished with modified pulse-echo instruments. This method, illustrated in Figure 4<sup>1</sup> uses sound waves emitted by one crystal which are directed at, and received by, a second crystal. The ratio of amplitude of pulses transmitted and received is a measure of the soundness or quality of material being tested. This method is used less frequently than the aforementioned pulse-echo methods.

For thickness measuring, both the pulse-echo straight beam search method and resonance methods are employed. The wall thickness may be calculated or read directly, depending upon the choice of test instrument.

#### 8.1.2.4 Ultrasonic Test Applications

Ultrasonic test methods may be applied to almost any material which is capable of transmitting high frequency sound waves, but find widest application for metals. For example, some steel mills are using ultrasonic methods for control of quality in rolled and forged carbon and alloy steel bar stock, forging billets, tubing and piping, and rolled plate. In general, angle beam searching is used for tubing and piping, and straight beam searching for the other mill items.

Straight beam searching is used also for plant maintenance-type inspection of:

1. Shafts and piston rods for fatigue cracks and other defects.
2. Clad vessels for areas of loose bonding between clad and base metal.

#### 8.1.2.4 - 8.1.2.5

3. Forged components for miscellaneous defects.
4. Miscellaneous equipment such as tanks, reactors and piping for determination of wall thickness.

Angle beam searching is used primarily for locating defects in pipe, tubing and weldments. In recent years, this technique has found considerable application in inspecting welds in nuclear power reactor pressure vessels, due to the critical nature of this service and the inability of radiographic inspection to detect fine cracks at undesirable orientations in welds in heavy plate.

Applications for surface wave searching include the detection of surface defects in hot and cold rolled sheet and plate, valve springs, extrusions and crank shafts. This method has been utilized in the internal probe method for detecting cracks in small diameter tubing.

The primary application for immersion searching is flaw detection in objects of irregular shapes where direct contact of the crystal and object is difficult. Typical examples are pump impellers, various complex forgings, extrusions and castings. Also, the reliability of this technique for inspecting metal plate in thicknesses down to  $1/4''^4$ , and pipe and tubing down to  $3/16''$  outside diameter<sup>5</sup>, has been demonstrated.

Resonance testing is, on occasion, used for the detection of laminations in metal plates. However, its primary application is the measurement of wall thickness of equipment both in and out of service, where access to only one side is possible.

#### 8.1.2.5 Sensitivity

The sensitivity of ultrasonic testing depends upon a multitude of factors, one of the most important of which is the degree of training and skill of the individual operating the test equipment. A high degree of operator training and familiarity with test methods and material being tested is required for distinguishing between extraneous indications and indications from defects.

Other factors include choice of test method, type of material under test, distance of defect from test crystal, orientation of defect with respect to direction of the sound wave, metal grain size, choice of crystal couplant (oil, water, etc.), surface roughness, test frequency, and others.

Using surface wave searching as an example, grooves 0.002" deep have been detected on a sheet metal surface having a surface finish of 25 r.m.s. In general, a defect depth of 0.005" appears to be a practical minimum. It is reported that inclusions 0.008-0.010" diameter located just below the surface in aluminum extrusions were detected by surface wave searching as far as 12' away from the crystal contact point. In carbon and alloy steel, it is expected that a similar defect could not be detected at so great a distance from the crystal, due to the poorer sound transmission qualities of steels compared with aluminum. The sound transmission qualities of the stainless steels are poorer than those of carbon steel.

A second example involved the use of angle beam searching to inspect fabricator's welds in 2-1/8" thick, 1-1/4 Cr-1/2 Mo alloy steel plate. Ultrasonic testing readily detected all defects revealed by x-ray examination, plus numerous indications from defects not shown on the radiographs. In one instance, a tight crack measuring approximately 1/4 x 3/8" (as revealed by sectioning the weldment) was outlined with the angle beam unit, but could not be detected by x-ray due to unfavorable orientation. Unfortunately, it was difficult to determine which ultrasonic indications were of such size to be considered rejectable.

There is, at present, no single measure of sensitivity applicable to all methods of ultrasonic testing encountered in industry. Sensitivity is usually measured in terms of amplitude of indications from artificial defects of a given size and shape in the part under test. Paragraph 8.1.2.7 contains some examples of the types of artificial defects used for calibration of ultrasonic testers.

Experience to date has indicated that defects in carbon and alloy steel weldments equal to or greater than a 1/64" diameter flat bottom hole can be detected ultrasonically using angle beam searching techniques. This level of sensitivity also applies in general to straight beam searching of plate, bar stock and forgings, but is dependent, of course, on distance of defect from the search crystal, type of metal, etc. Using angle beam methods on tubing and piping, a defect 3% of the wall thickness is considered to be the practical minimum level of detection.

Most of the aforementioned factors also limit the sensitivity and accuracy of ultrasonic thickness determinations. Using either pulse-echo or resonance methods, practical limits on accuracy are plus or minus 3% of the thickness being measured.

## 8.1.2.6

### 8.1.2.6 Ultrasonic Testing Techniques

#### a. Variables

##### (1) Test Frequency

The choice of ultrasonic test frequency is generally dependent upon the type and thickness of material under test, suspected location of defects, and the sensitivity and accuracy required. For example, for pulse-echo detection of defects, the higher frequencies (5-10 mc) are used where the suspected flaws lie close to the test surface, and where maximum sensitivity is required. The lower frequencies (0.5-5 mc) are used to detect defects at considerable distance from the test surface due to the greater penetrating power and less beam divergence of low frequency waves. Most angle beam searching is done at frequencies of 2-1/2 mc or less, since the beam must travel twice as far as a straight beam, and thus requires good penetration.

For thickness measurements by resonance methods<sup>5</sup> low frequency ranges (e.g. 0.75 - 1.5 mc) are used for materials above 0.75" in thickness, poor ultrasonic conductors and severely corroded materials. High frequency ranges (e.g. 6-12 mc) are required for materials less than 0.025" thick, measurement of small diameter tubes (less than 3/4" O.D.), and high accuracy measurement of materials less than 0.075" thick. The range of 2-6 mc which overlaps these high and low ranges, is the most useful for general application in the thickness range of 0.020" to 0.75".

##### (2) Couplants

All ultrasonic test methods require the exclusion of air between the search crystal and surface under test, since air is a poor transmitter of sound waves. Therefore, this air space is filled with a fluid couplant to reduce extraneous indications and beam spread. Water is the most common couplant for immersion searching; the choice of couplants for direct contact testing depends upon test surface roughness, and degree of sensitivity required. A light oil similar in viscosity

to SAE No. 10 fulfills most direct contact test applications. Glycerine containing a small amount of wetting agent is used for maximum sensitivity at high frequencies or on rough surfaces. High viscosity fluids such as heavy oils and greases are used at low frequencies and on smooth surfaces.

Testing of hot surfaces (100°C-200°C) requires high temperature search units and special couplants. At these temperatures, ordinary oils become highly liquified and may even vaporize between the crystal and test surface, resulting in severe attenuation or loss of indications. Certain silicone and halocarbon oils and greases have been used successfully under these conditions.

### (3) Search Crystals

The ideal search crystal<sup>2</sup> would have a high conversion factor of electrical to mechanical energy, would respond uniformly over a wide frequency range, would have no internal resonances, and would transmit a straight beam over long distances. Unfortunately, the best available crystals are a long way from the ideal, and the shortcomings are most apparent at lower frequencies.

Quartz is the most common crystal for both pulse-echo and resonance testing. Barium titanate crystals are used in resonance determinations of wall thickness, due to greater sensitivity compared with quartz. A relatively new crystal material, lithium sulfate, is finding widespread application for both pulse-echo and resonance methods, flaw detection as well as thickness measuring, due to appreciably higher sensitivities than quartz or titanate.

Flat crystals are applicable to all flat shapes as well as slightly curved ones, such as large cylindrical tanks. Small flat crystals (1/2" diameter or less) can be used on highly curved surfaces such as pipe and tubing. However, for the latter application, it is best to use a crystal ground to fit the curvature of material under test, for maximum sensitivity. These crystals apply to inspection from the external surface of equipment. Spring-loaded curved crystals are also available for measuring the wall thickness of pipe and tubing from the internal surface.

#### 8.1.2.6

The maximum temperature limitations of the various types of crystals are as follows:

1. Quartz - 150°C.
2. Lithium sulfate - 150°C.
3. Barium titanate - 80°C. (due to depolarization above 100°C.)

The temperature limit of the first two crystals may be extended to over 200°C. by protective aluminum oxide and high temperature epoxy resin coatings over the crystals.

#### (4) Surface Preparation

Probably the ideal test surface for ultrasonic inspection is a machined surface finish of about 63 r.m.s. However, this is rarely encountered in the majority of applications for this type of test. In general, all loose paint and scale should be removed from the surface by chipping, wire brushing and/or light sand blasting. Otherwise, the sound beam will be attenuated or completely reflected from the interface between paint or scale and the test surface. However, a thin coating of tightly adherent paint will transmit sound with only slight beam attenuation. At times, polishing with sandpaper or a disc sander is required after wire brushing, particularly on pitted surfaces, if maximum sensitivity is desired.

Extremely rough surfaces (i.e., a high concentration of deep pits) are extremely difficult to inspect due to scattering of the sound beam by the uneven surface. Spot inspection is accomplished by grinding or sanding small areas (one or more times the crystal area) to solid metal, to provide a good contact surface for the crystal. A complete inspection may be achieved by first wire brushing and then coating the surface with a tightly adherent plastic material such as catalyzed epoxy resin. This results in some beam attenuation but reduces considerably the scattering caused by the rough surface.

## b. Weld Inspection

Ultrasonic inspection of welds has drawn considerable attention in recent years, due primarily to continually rising inspection costs and demand for higher quality welds in equipment in critical services. This interest is also reflected in the fact that societies such as ASTM and ASME are currently engaged in drawing up specifications and standards for this type of test.

Angle beam searching is the best method for locating defects in butt welds. Straight beam techniques are used for special welds such as nozzles, internal heads, etc. Figure 5 shows typical indications obtained from straight beam searching of a weld joining an internal head with the shell of a high pressure reactor.

In angle beam searching of butt welds, the first requirement deals with the surface condition of equipment under test<sup>o</sup>. The base material on either side of the weld must be cleaned of weld spatter and extreme roughness in order to assure intimate contact between crystal and surface. The internal and external weld beads must be blended smoothly into the base metal, with no undercutting, ridges or gross irregularities which would interfere with interpretation of indications appearing on the instrument cathode ray screen.

The instrument is calibrated on a test block equivalent in thickness and properties to the material under test, and containing artificial defects. In one method for the location of defects, as shown in Figure 6, the search unit is fitted with a clear plastic "ruler" which enables the operator to determine the location of flaws within the weld deposit. A 2" thick test block was chosen for purposes of illustration. The search unit is positioned on one face near the edge of the block, and moved away from the edge until an indication is obtained from the bottom corner. The location of maximum amplitude of this indication is marked on the cathode ray screen (1B). The distance from the face of the search unit to the edge of the test block is measured and marked on the plastic "ruler." In this manner, indications from the top corner, drilled hole, and bottom corner (2B) are obtained and located on the cathode ray screen and plastic "ruler"

### 8.1.2.6

by appropriate markings. If all of these indications could be obtained simultaneously, the cathode ray screen would appear similar to the bottom sketch in Figure 6. Once calibration is accomplished, instrument settings remain constant throughout the inspection.

Welds are scanned by moving the search unit forward and backward, alternately approaching and moving away from the weld, a distance sufficient to permit the sound waves to pass through the full thickness of the plate and the weld in both an upward and downward path. Also, the search unit is moved laterally, parallel to the weld itself, a distance not to exceed one crystal width for each forward and back cycle. The resulting scanning path is shown in Figure 7. Both adjacent sides of the weld are scanned in this manner; thus, the sound wave strikes possible defects from four directions (upward, downward, and from either side).

Once an indication from a possible defect is obtained, its location and approximate size must be determined. The search unit is moved laterally along the weld to see if the defect has any length, and toward and away from the weld to determine depth. If the amplitude falls off and disappears with only slight lateral, forward and backward movement, it is assumed that it is a point defect such as a spot of porosity or slag inclusion. The size of the defect is approximated by comparing the amplitude of the indication with that from the drilled hole in the test block. Defects which have length and/or depth may be elongated slag inclusions, cracks, lack of fusion or laminations in plate adjacent to the weld. Since identification of the type of defect is difficult, an ultrasonic test is usually followed by x-ray for positive identification.

The position of the defect within the weld deposit is estimated with the aid of the plastic "ruler", location of the indication on the cathode ray screen, and knowledge of weld geometry and path of the sound waves. Referring to Figure 6, for example, if a defect should appear at Position "H" on the screen, and Line "T" on the ruler is directly over the center of the weld, the sound wave is moving upward to strike the defect, which is about halfway between the top and bottom of the weld, and on the search

unit side of the weld centerline. Knowing the weld geometry, the operator can decide whether the defect is in the weld deposit, adjacent base metal, or weld metal - base metal fusion line.

### c. Inspection of Pipe and Tubing

Pipe and tubing is inspected for defects by both direct contact and immersion techniques. Angle beam searching has been found to be the most effective for direct contact testing. Choice of angle of the sound beam is based upon the wall thickness and outside diameter of the material under test. A 45° angle search unit is applicable to most of the common sizes of tubing and pipe.

The search unit is fitted with a plastic "shoe" which is ground to the curvature of the tube O.D. The instrument is calibrated on a sample of tubing equivalent in dimensions and properties to the test material. The sample tube contains both longitudinal and radial artificial defects, usually notches having depths 3-5% of the tube wall thickness. The amplitudes of indications from the notches are located on the cathode ray screen by appropriate markings.

The tube is scanned for longitudinal defects by positioning the search unit so that the sound path entering the tube wall is parallel to the tube radial axis (Figure 8a). The tube is rotated and moved past the search unit so that 100% of the tube is inspected. In similar fashion, the tube is scanned for radial defects (Figure 8b) except that in this case, the search unit is positioned so that the sound path entering the tube wall is parallel to the tube longitudinal axis. At times the search unit is positioned so that the sound path enters the tube wall between the tube radial and longitudinal axes, and assumes a spiral path around the tube. This technique will locate both radial and longitudinal defects, but with some loss in sensitivity compared with the above techniques.

For inspection of pipe and tubing on a production scale, the search equipment is completely automated. Indications from artificial defects are located on a recorder which contains an audible and/or visible alarm and a strip chart. Tubing is

#### 8.1.2.6 - 8.1.2.7

coated with a fluid couplant and passed continuously beneath the search unit. When a defect is found which is equal to, or larger than the artificial defect, an alarm is given, the amplitude of the defect indication is recorded on the strip chart, and the defect is located on the tube surface simultaneously with a paint spot. Thus defective areas can be located merely by examining the strip chart and tube for paint spots.

Immersion searching has been found to be a desirable method for inspecting pipe and tubing. Reference 5 reports on the use of this method for inspecting pipe and tubing for nuclear power reactors. Thin-walled tubing down to  $3/16$ " O.D., and piping to 8" O.D. was inspected with good sensitivity and dependability.

#### d. Inspection of Plate

Both direct contact and immersion search methods are used for inspecting sheet and plate for laminations and other defects. Surface wave, straight beam and angle beam searching techniques are applicable, depending upon thickness of plate, and location and type of defect. For all methods, the plate is generally laid out to assure 100% inspection. A typical layout is a series of longitudinal and transverse grid lines 6" apart creating 6" squares. The lines are followed by the search unit in both directions, using a weaving motion to cover a path about 3" wide on either side of the lines.

Surface wave searching is used on thin sheet, or where defects at or very close to the surface are of concern. The instrument is usually calibrated on sheet of thickness and properties equivalent to the material under test, and containing artificial notches of depth equal to a specified percentage of the sheet thickness.

#### 8.1.2.7 Ultrasonic Test Specifications

##### a. Military Standard

Military Standard MIL-STD-271B (Ships) defines procedures as well as acceptance limits. For this reason, it is widely used throughout industry as an ultrasonic testing specification for use in purchasing mill items from vendors.

b. ASTM Specifications

In all of the ASTM Specifications, the inspection procedures are reasonably well defined, but acceptance-rejection limits are subject to agreement between the purchaser and vendor. Thus when referring to these specifications, the purchaser must define precisely the acceptance standards with complete agreement from the vendor for assurance of quality material. A listing of pertinent ASTM Specifications is given below:

E164 - Tentative Method for Ultrasonic Contact Inspection of Weldments.

This tentative method outlines a procedure for inspecting weldments using the pulse-echo angle beam search method. It covers surface preparation and inspection technique but does not define adequately a means for determining the position of a defect within the weldment.

A388 - Recommended Practices for Ultrasonic Testing and Inspection of Heavy Steel Forgings.

This recommended practice refers to other ASTM Specifications for recommended practices for pulse-echo and resonance testing. All details of test procedure must be specified by the purchaser.

A435 - Tentative Method and Specification for Ultrasonic Testing and Inspection of Steel Plates of Firebox and Higher Quality.

This tentative method covers direct contact pulse-echo straight beam searching of plate for defects and outlines scanning procedures. Acceptance standards are subject to agreement between purchaser and supplier.

E113 - Tentative Recommended Practice for Ultrasonic Testing by the Resonance Method.

This tentative recommended practice outlines practices for measuring wall thickness and locating certain defects with direct contact resonance methods. It covers calibration, procedures, and interpretation of indications.

c. Commercial Specifications

Producers of tubular products, plate, bar stock, and forgings have written specifications to which they will check their respective products when ultrasonic inspection is required by customers. The material listed below is taken from some representative specifications:

(1) Bar Stock (17-4PH)

General Requirements: In accordance with MIL-STD-271 (Ships), except as noted below:

Size Range: All bars having a diameter or thickness 1" and over.

Procedure: Sufficient inspection to be performed to determine maximum response from a defect. Bars which cannot be rotated, such as squares, shall be inspected from all sides.

Test Frequency: Five megacycles using 3/4" diameter of 1-1/8" diameter longitudinal wave search crystal. While testing bars by the contact method the equipment shall be adjusted to produce a 1" peak-to-peak indication from the 1/64" diameter flat bottom hole in a No. 1 Alcoa Series A reference standard. When testing by the immersion method, the ultrasonic equipment shall be adjusted to produce an indication at least 40% of full screen indication from a 3/64" diameter flat bottom hole drilled radially in a bar of 17-4PH of approximately equal diameter and surface roughness as the bar to be inspected.

(2) Nuclear Piping and Heat Exchanger Tubing

Any suitable ultrasonic pulse-reflection type of instrument coupled to an angle searching unit shall be used.

Material to be tested shall be completely explored. Material shall be spirally fed in one direction with a feed helix less than one crystal diameter.

### 8.1.2.7

A calibration standard nominally 6" long shall be prepared from a randomly selected piece of the pipe or tubing to be tested. A longitudinal V-shaped notch shall be machined on the O.D. at one end of the standard and on the I.D. at the other end. These notches shall have the following nominal dimensions:

- Angle of V - The included angle shall be as small as possible. It shall not exceed 35°.
- Depth - Equivalent to the maximum defect depth permitted by the applicable pipe or tubing specification but in no case less than 3% of the nominal wall of the pipe or tubing or 0.004", whichever is greater.
- Length - Approximately 1-1/2".

During the calibration of the instrument the oscilloscope screen shall be marked to show the "pip" height indicated from the O.D. or I.D. notch whichever is lower, and these marks will indicate the maximum height of defect permissible. The defect "pip" shall be observed as close as possible to the initial pulse.

One calibration standard as described above shall be prepared from each size of tubing or pipe on each order.

Calibration shall be accomplished with the calibration standard rotating at the same uniform rate as will be used for testing the pipe or tubing from which it was selected.

The following factors shall be adjusted so as to achieve an optimum instrument distinction between notched and unnotched portions when testing the calibration standard described above:

- Ultrasonic wave entry angle.
- Ultrasonic test frequency.
- Instrument sensitivity.

### 8.1.2.7

Any pipe or tube showing a defect indication which exceeds the "pip" height established from the calibration standard shall be rejected. Any pipe or tube not showing such a defect indication shall be considered as having passed the ultrasonic test. Manufacturer reserves the right to salvage (where practicable) rejected pipe and tubing and retesting after elimination of the cause of the defect indication, providing such elimination will not otherwise be considered rejectable within the specification.

#### (3) Plate

When ultrasonic testing is performed at the supplier's plant, straight beam (longitudinal wave) testing on 100% of the surface will normally be used. Plates furnished to this quality shall be free from discontinuities giving ultrasonic indications exceeding that obtained from a 1/4" diameter flat bottom hole contained in a stainless steel reference plate prepared at the plant.

When angle beam (shear wave) testing is employed, plates furnished to this quality shall be free from discontinuities giving ultrasonic indications produced from an indented notch the depth of which is 3% of the thickness of the material being tested or ultrasonic indications exceeding that obtained from a 1/16" diameter hole drilled parallel to the surface of the plate.

More restricted standards of acceptance will be subject to negotiation.

In addition, if complete loss of back reflection is encountered which cannot be attributed to surface condition or grain size, the plate will not be considered ultrasonic quality.

On plates that are not ordered to ultrasonic quality, but subsequently tested by ultrasonic methods, rejections will not be considered for internal discontinuities beyond 3" from the plate edges.

(4) Forged Pipe Flanges

Inspection shall be performed by the immersed pulse reflection method. The test frequency shall be 2.25 to 10 megacycles as applicable and necessary.

Calibration shall be based on the end reflection and shall be recorded as percentage of back reflection or as percentage loss of back reflection in accordance with interpretation specified below.

Where the geometry of the test piece prohibits obtaining an end reflection the transducer shall be normalized with respect to the test piece and the instrument adjusted for a maximum front reflection. Internal defects shall be recorded as percentage of end reflection based on calibration against a parallel faced section of approximately the same thickness at the same instrument settings. Such angular manipulation as is necessary shall be used to determine the magnitude of a defect indication.

Sections with parallel faces shall be tested from both transverse surfaces allowing sufficient overlap to check 100% of the surface. Nonparallel sections shall be tested to the maximum extent possible.

When testing through parallel cross sections one or more areas exhibiting a complete loss of back reflection shall be subject to rejection; areas exhibiting as much as a 50% loss of back reflection shall be recorded and reported; and defects exceeding 10% of a  $3/4$  amplitude end reflection shall be subject to rejection or review.

Defective areas encountered when testing through irregular cross sections shall be subject to rejection or review if the indications are in excess of 10% of the  $3/4$  amplitude end reflection obtained from a section with parallel faces having approximately equal thickness.

#### 8.1.2.7 - 8.1.2.8 - 8.1.2.9

Defects indicated by these tests shall not be the sole basis for rejection except at the option of the manufacturer. However, in order to furnish finished flanges having the required high degree of internal soundness, material showing defect indications in excess of calibration standard shall be subjected to further investigation by such nondestructive or destructive tests as are necessary to insure the integrity of the finished product.

Results of said additional testing shall be the criterion for rejection or submission for review by the purchaser.

#### 8.1.2.8 Cost of Ultrasonic Inspection of Mill Products

Most mills offer this inspection as an "extra". For example, a large producer of tubular products adds about 20% to the base price of small diameter stainless steel tubing for ultrasonic inspection in moderate quantities. For carbon steel tubing, however, the cost extra varies according to tube size and quantity. Ultrasonic inspection of small diameter tubing in large quantities will cost an additional 30-40% of the base price.

As an example of the cost of ultrasonic testing of plate, a large producer of stainless steel plate adds 10% to the base price as a quality extra, plus \$0.25 per square foot of plate area as a testing extra to perform this service. The minimum testing charge is \$110 regardless of plate quantity. This applies to commonly used materials such as Type 304L. Other materials may be slightly higher.

#### 8.1.2.9 Cost of Ultrasonic Test Equipment

A typical portable pulse-echo instrument for flaw detection and thickness measurement, capable of being used for immersion testing costs \$5000-\$6000 for the instrument, one cable, and crystal. Additional crystals cost \$75-\$200 each. This unit operates on 110V power supply.

A typical battery powered portable resonance instrument for thickness measurement, where thickness must be determined by calculation, costs about \$1000 for the instrument with one cable and crystal. Crystals cost \$50-\$200 each.

A portable resonance unit for thickness testing which gives measurements directly on scales in front of a cathode ray tube costs about \$2000 for a 14" model with one cable, oscillator, scale, and crystal. Additional scales for different thickness ranges cost \$75 each, oscillators \$285 each, and crystals \$100-\$150 each. This unit operates on 110V power supply.

#### 8.1.2.10 Advantages and Limitations

The desirable features of ultrasonic testing include<sup>7</sup>:

1. High sensitivity, permitting detection of minute defects.
2. Great penetrating power, allowing examination of extremely thick sections.
3. Accuracy in the measurement of wall thickness, flaw position and estimation of flaw size.
4. Fast response, permitting rapid and automated inspection.
5. Need for access to only one surface of specimen.

Ultrasonic testing may be limited by one or more of the following factors:

1. Requires highest degree of operator skill and training for precise interpretation of test data.
2. No provisions for a permanent record of the shape of defects, as in radiography.
3. Undesirable internal structure such as large grain size, porosity, high inclusion content, dispersed precipitates, etc.
4. Unfavorable specimen surface conditions, such as pitting, heavy scale deposits, heavy paint coatings, etc.
5. Unfavorable specimen geometry, such as minute size, unusual contour and complexity, unusual defect orientation within specimen, etc.
6. High attenuation of ultrasonic waves in certain materials, e.g., cast iron, sintered carbides and plastics.
7. Dampening or complete loss of indications due to elevated temperatures, fluids and internal deposits in equipment under test.

8.1.2.11

SOURCES OF INFORMATION:

1. "Operating Manual for Type Uh 'Reflectoscope'", The Sperry Products, Inc., Danbury, Conn.
2. Harris, R. V., and Bobbin, J. E., "Frequency Dependent Effects in Ultrasonic Resonance Testing", Nondestructive Testing, Sept. - Oct., 1960.
3. "Ultrasonic Inspection with the Sperry Reflectoscope", Bulletin 50-105, Sperry Products, Inc., Danbury, Conn.
4. McClung, R. W., "The Immersed Ultrasonic Inspection of Metal Plate", Nondestructive Testing, Sept. - Oct., 1959.
5. Oliver, R. B., McClung, R. W., & White, J. K., "Immersed Ultrasonic Inspection of Pipe and Tubing", Nondestructive Testing, May - June, 1957.
6. Bobbin, J. E., "Ultrasonic Weld Inspection - A Status Report", Nondestructive Testing, May - June, 1960.
7. "Nondestructive Testing Handbook", Vol. 2, Edited by Robert C. McMaster, The Ronald Press Co., 1959.

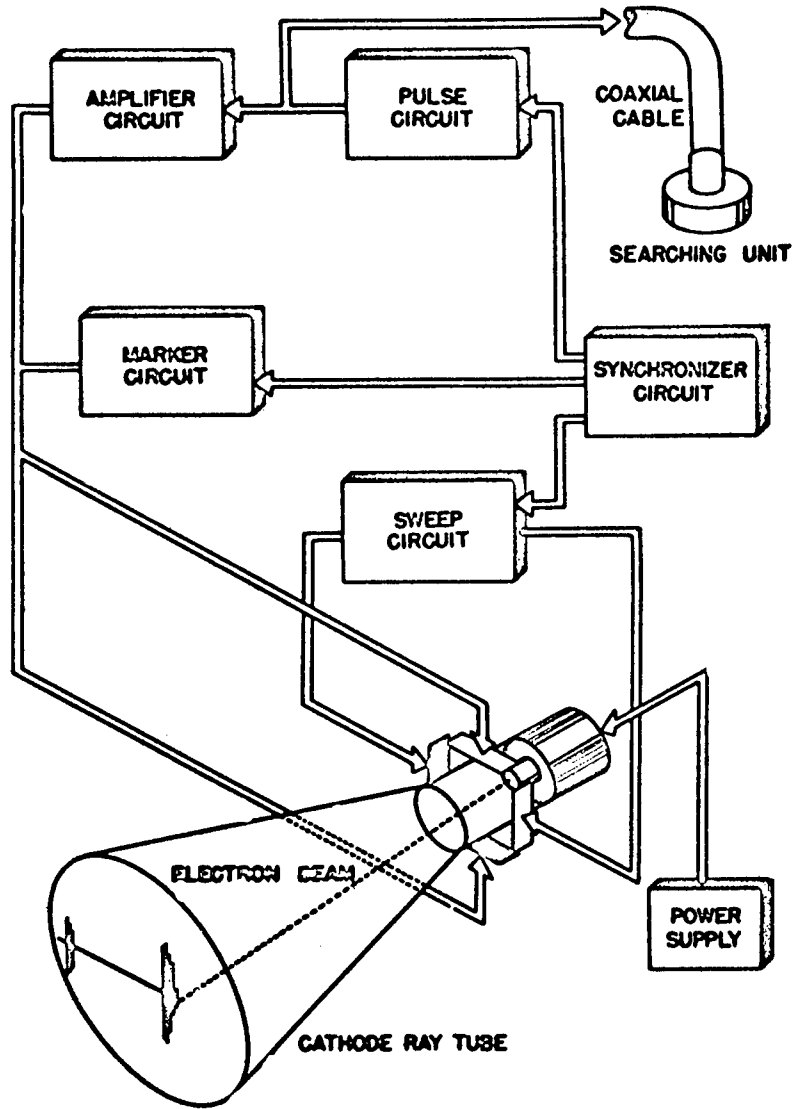

Fig. 1 Diagrammatic Representation of the Function of the Components of an Ultrasonic Test Unit

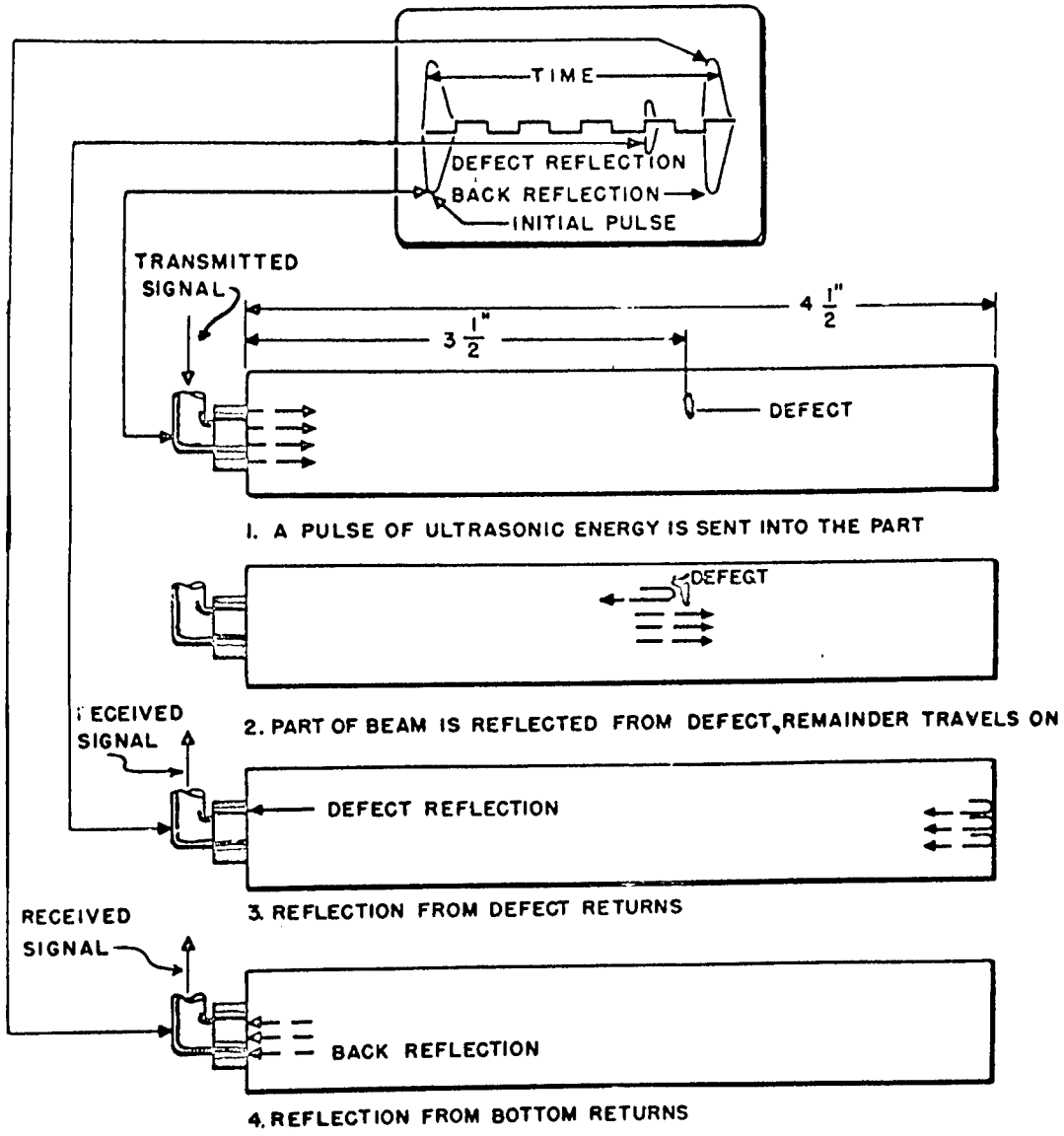

Fig. 2 Theory of Operation of an Ultrasonic Test Unit Using the Pulse-Echo, Single Searching Unit Method and the Straight Beam Testing Technique

**methods of search**

*straight beam search unit*



(a)

Used to locate defects by projecting a beam perpendicular to the test surface.

*angle beam search unit*

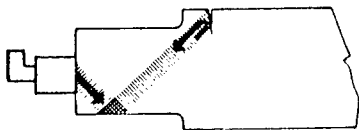

(b)

Used to locate defects by introducing a beam of vibrations at an angle to the surface of the test material. In this manner, discontinuities are located which, due to their orientation, cannot be detected by the straight beam technique.

*surface wave search unit*

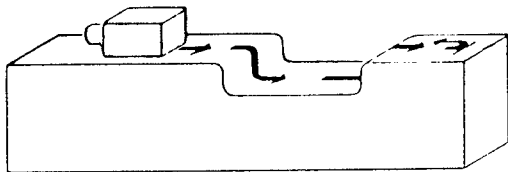

(c)

Used to project a beam of vibrations which travel along the surface and just below the surface of the material. These vibrations will travel over irregular shaped surfaces.

*immersion type search unit*

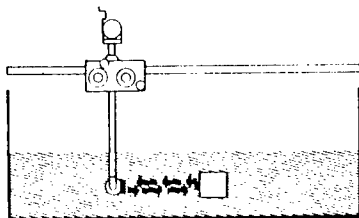

(d)

Used to inspect materials while immersed in a suitable liquid such as water or oil. This method proves more satisfactory than contact testing for irregular shaped surfaces. Immersion inspection also permits use of a wider range of testing frequencies. Straight beam or angle beam techniques are used by varying the angle of the search unit head in relation to the test surface.

Fig. 3 Ultrasonic Search Methods

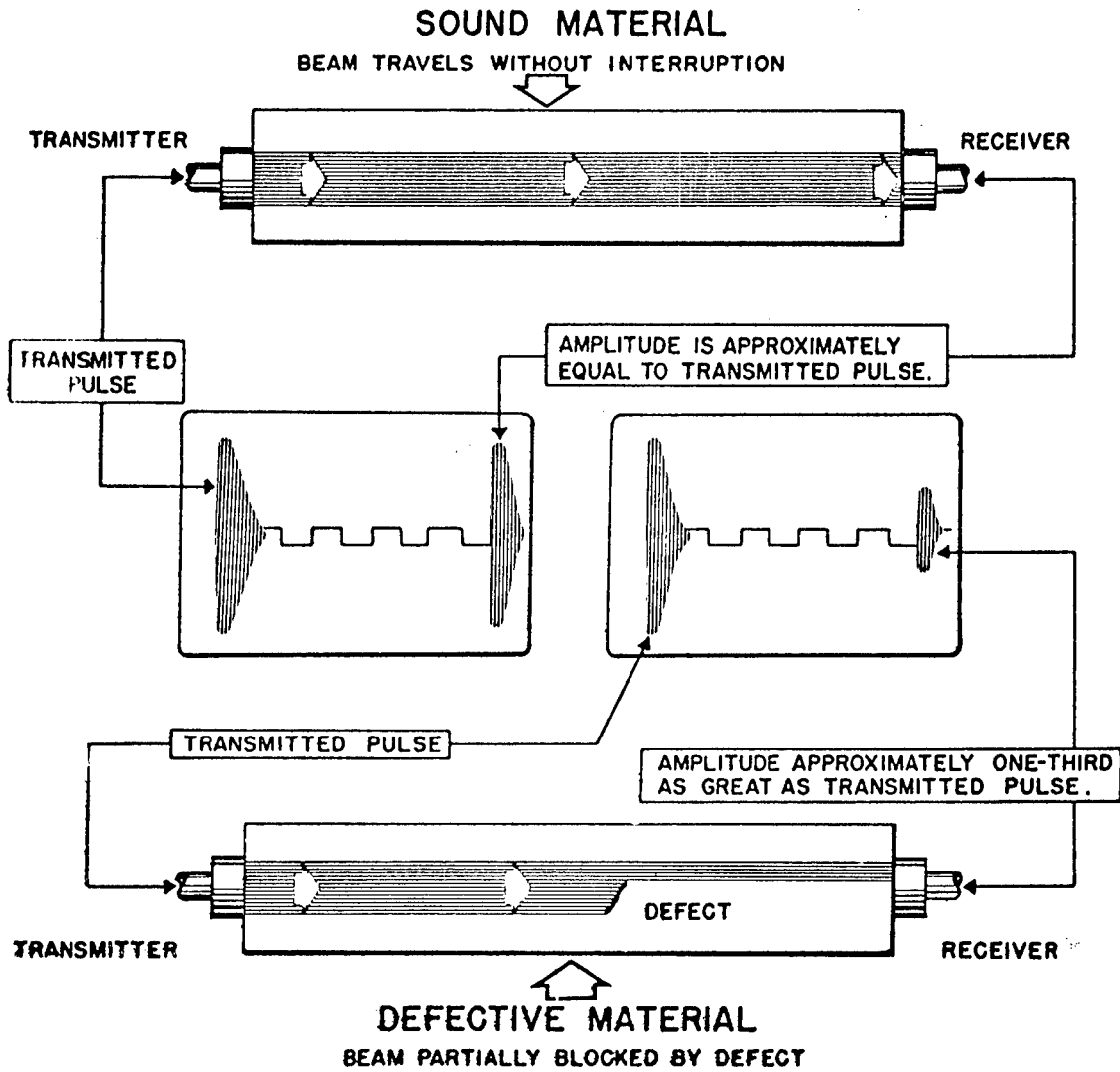

Fig. 4 Theory of Operation Using Double Searching Unit Equipment for Through Transmission Testing

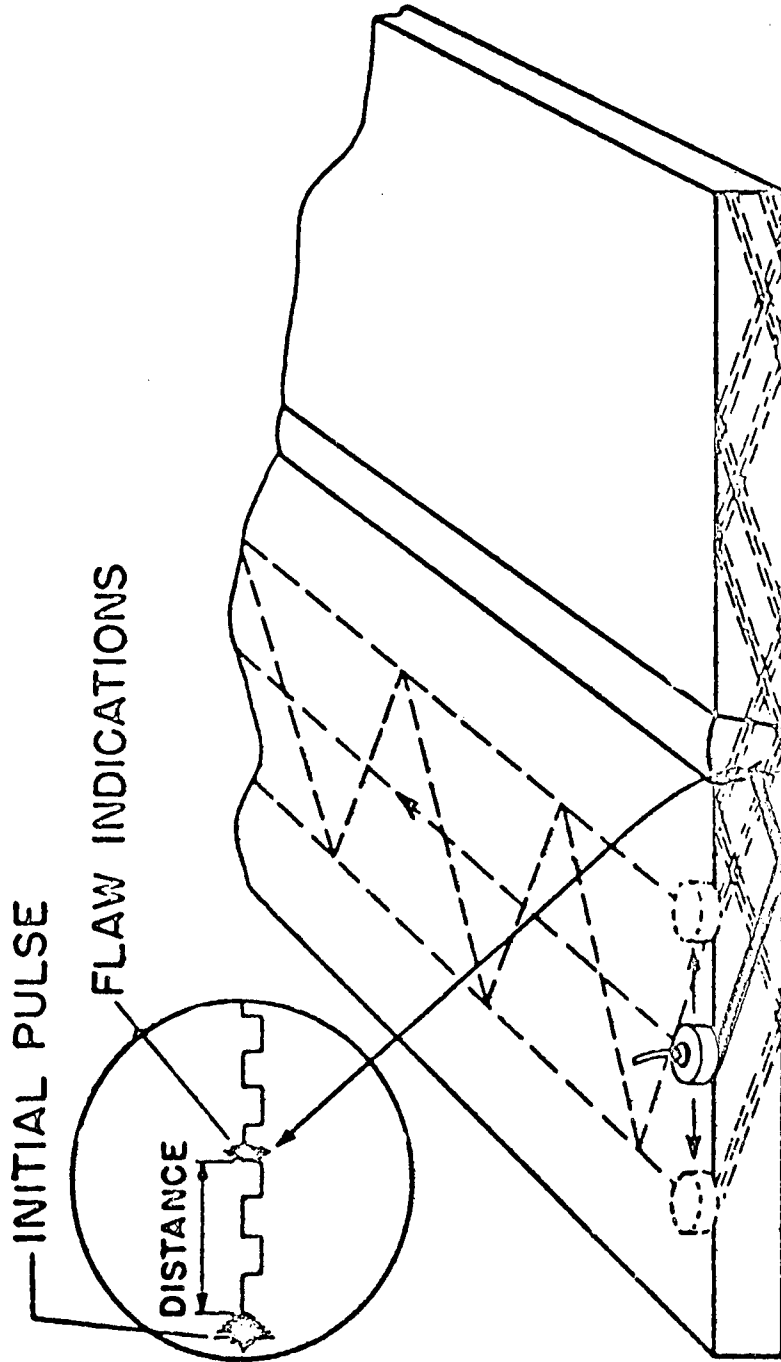

Fig. 7 Ultrasonic Testing of a Weld with the Ultrasonic Angle Beam or Shear Wave Technique

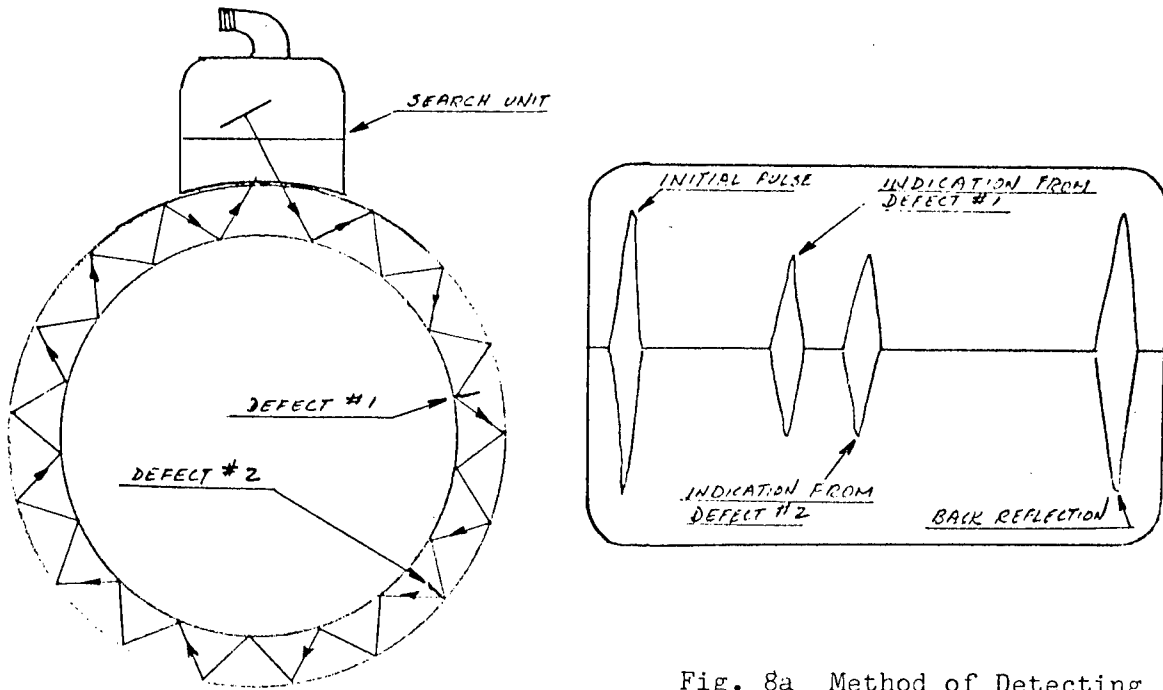

Fig. 8a Method of Detecting Longitudinal Defects in Pipe

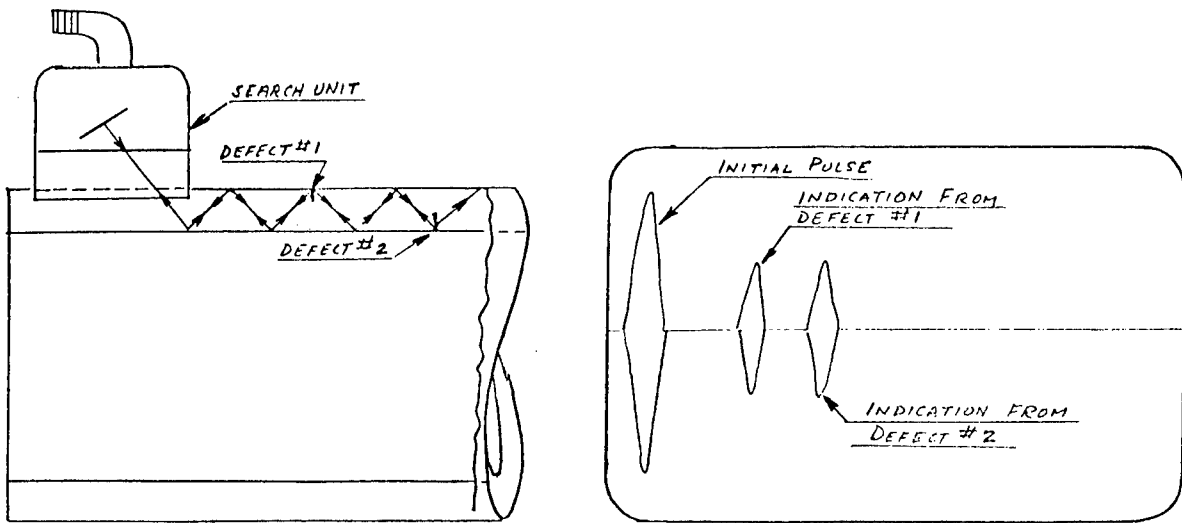

Fig. 8b Method of Detecting Radial Defects in Pipe

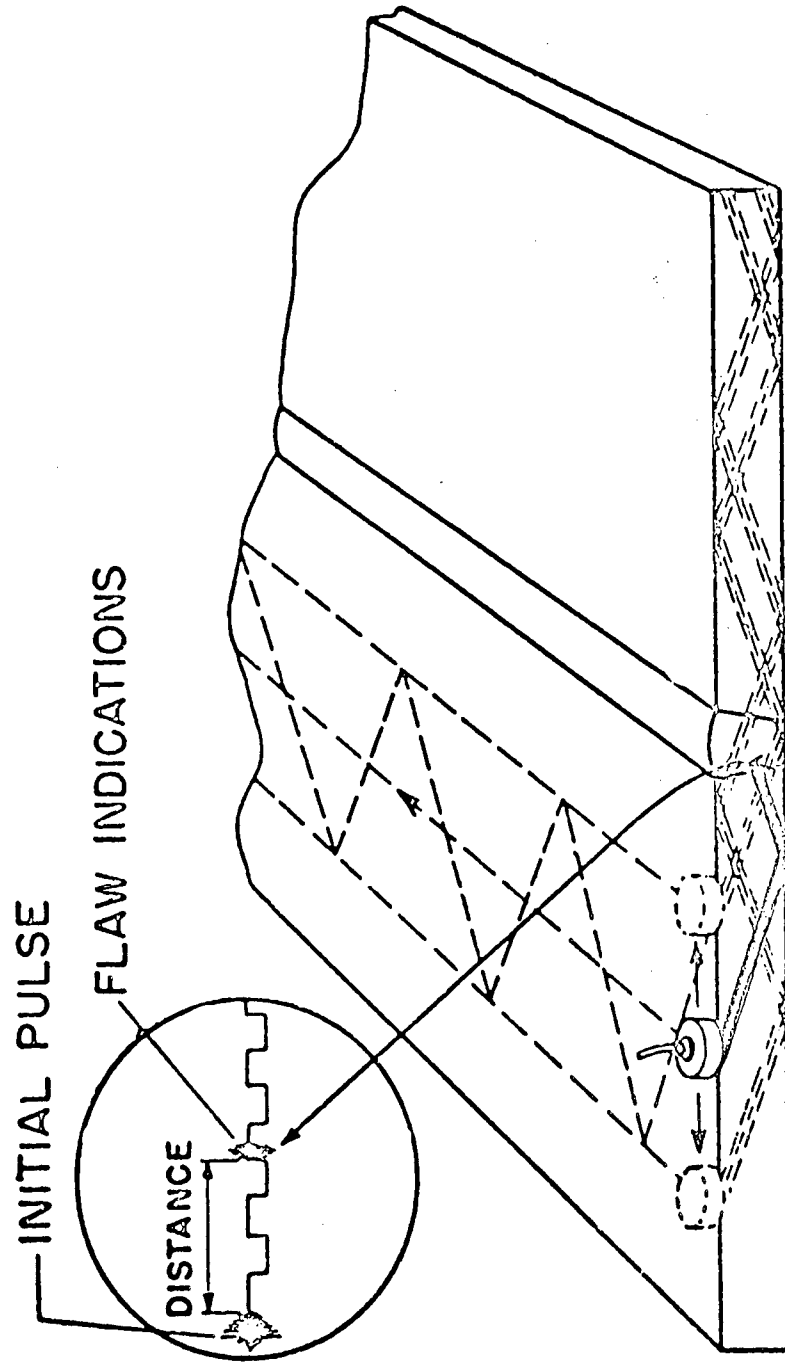

Fig. 7 Ultrasonic Testing of a Weld with the Ultrasonic Angle Beam or Shear Wave Technique.

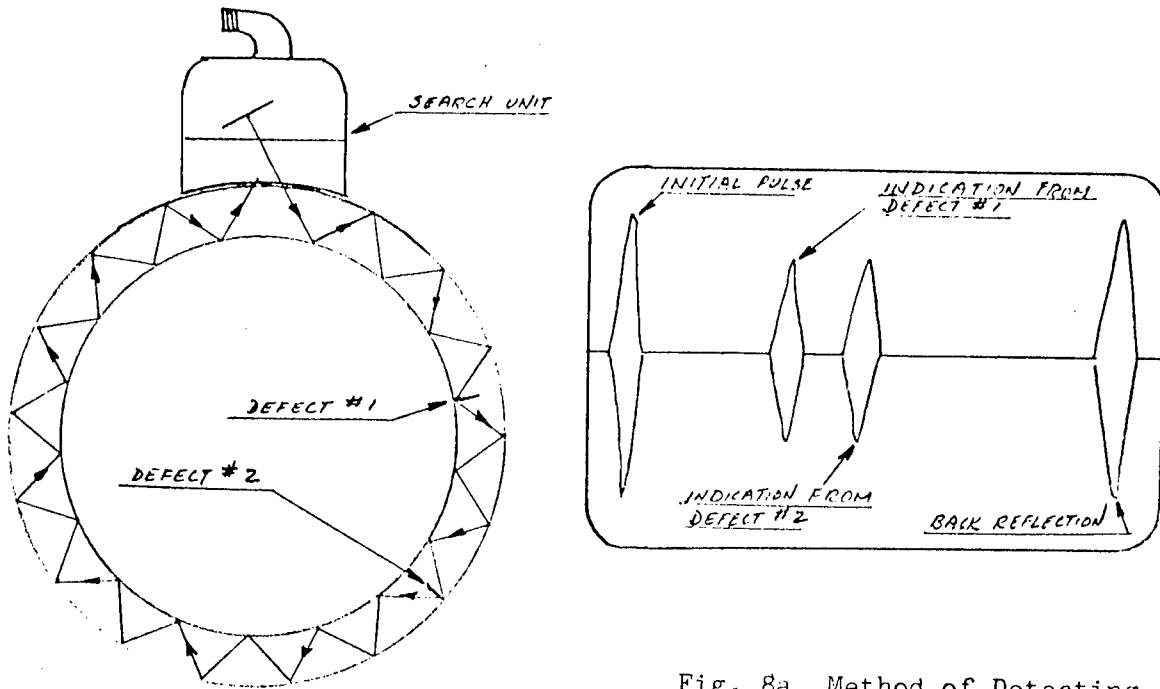

Fig. 8a Method of Detecting Longitudinal Defects in Pipe

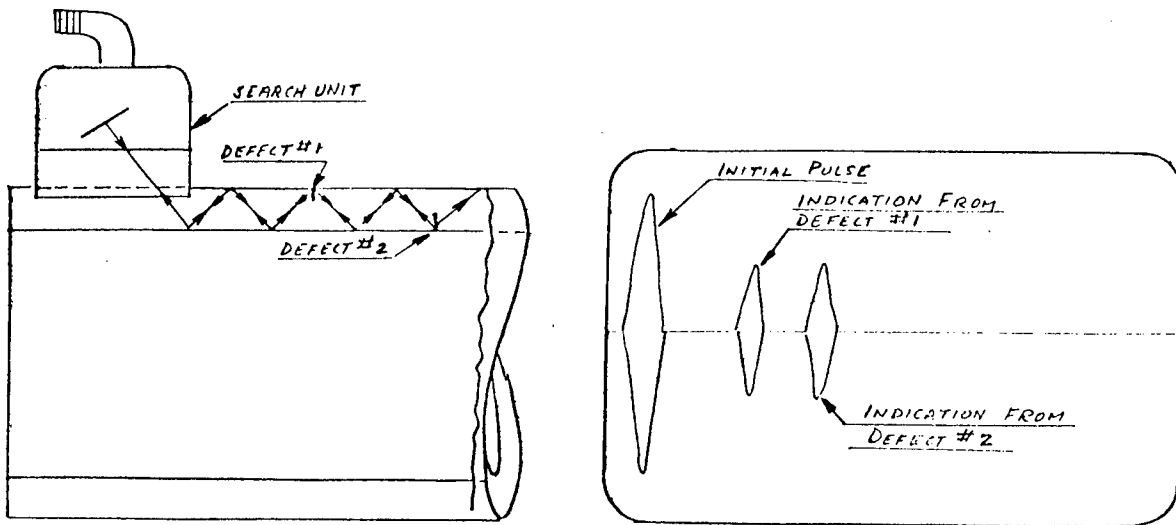

Fig. 8b Method of Detecting Radial Defects in Pipe

### 8.1.3 Eddy Current Testing

#### 8.1.3.1 Scope

Although eddy current testing is applicable to many types of nondestructive testing including sorting of alloys, determination of heat treatment condition in a given alloy, measuring plate and tube wall thicknesses, rod and tubing diameter, electrical conductivity, and cladding thicknesses, this section will be concerned with the application which probably has the greatest value for the nuclear field and chemical process industry field, that of detection of discontinuities in tubular products such as heat exchanger tubing.

As a quality control measure in the manufacture of metallic tubing, it is now common practice to pass such tubing through encircling coils of an eddy current tester at speeds sufficiently high to make this type of nondestructive testing equipment a valuable production line tool.

A variation of the eddy current test method in which a coil is pulled through tubular items is frequently used for the field inspection of tubing in equipment items such as heat exchangers which have been in service. Testing equipment which utilizes the internal probe method was developed by Shell Development Company under the name "Probolog". Branson Instruments, Inc. has been licensed by Shell to manufacture the "Probolog".

#### 8.1.3.2 Principles

Eddy currents have been useful in many ways, important commercial applications being in the induction motor, in induction heating, and in eddy current testing.

In eddy current testing, eddy currents are caused to flow in the test sample and are observed and compared with eddy currents which flow or which should flow in a "standard" or acceptable sample. Variations of current flow exceeding an established limit determined by both theoretical and experimental considerations of the particular test indicate the presence of an undesirable defect. The detection problem is complicated, since the currents must be observed by inductive means and by the fact that any variation in test or test sample conditions, such as coil to specimen spacing, specimen electrical conductivity, magnetic permeability, shape, surface condition, presence of inclusions, voids, or cracks may affect the flow of eddy currents. In some cases acceptable variations in quality of a specimen may cause a greater effect on the flow of eddy currents than an unacceptable defect. Fortunately in many instances such effects may be discriminated against by utilizing the time or phase relations of the eddy currents as well as their amplitude.

### 8.1.3.2

To illustrate the basic eddy current test, consider a coil having negligible resistance connected to an alternating current generator with no test specimen near the coil. An exciting current flows in the coil and establishes an alternating magnetic field. During two quarters of the alternating current cycle, say the first and third, energy is stored in the magnetic field of the coil, and during the other two quarters, say the second and fourth, it is being returned to the generator. The voltage induced in the exciting coil can be used as an indication of the stored energy. The voltage induced in a sensing coil placed adjacent to the exciting coil may also be used to indicate the stored energy, or in the general case, the magnitude and phase of the magnetic field. The more nearly such a sensing coil occupies the same space as the exciting coil, the more accurately will it give a measure of the magnetic field changes threading the exciting coil. Two basic eddy current test coil arrangements are shown in Fig. 1.<sup>2</sup>

When a conducting test specimen is placed near the exciting coil, eddy currents are induced in it due to electromagnetic induction. There are a very large number of metallic circuits within the test specimen, and each current loop which flows exerts its own electromagnetic inductive effect upon all other current loops.

An electrical phenomenon called skin effect which tends to concentrate currents near the surface of conductors closest to the field sources which produce them is active in all eddy current tests. The skin effect is caused by mutual interaction of the magnetic field of the exciting currents and the magnetic field of the eddy currents flowing in the test object, and results in current distributions of the type given in the equation in Fig. 2. In an ideal case, that is, for uniform magnetic fields, the currents decrease exponentially as depth below the surface increases. The depth of penetration is defined as that depth at which the current has become equal to  $i/e$ , or approximately 37% of its value at the surface. The current decreases more rapidly with increasing depth for higher test frequency, higher conductivity and higher magnetic permeability of the test object. The depth of penetration is also affected by coil geometry.<sup>2</sup>

It is helpful in analyzing the output of the eddy current test coil to plot its impedance or output signal voltage on the impedance plane as shown in Fig. 2. The resistive component of the coil impedance is plotted along the vertical axis. Changes in test object conditions result in various values of coil resistance and reactance giving characteristic loci on the impedance plane. One such loci obtained by varying test object conductivity for the flat probe test coil case is shown.<sup>2</sup>

Eddy current nondestructive test instrumentation covers a range from the simplest alternating current bridge circuits and current and voltage amplitude measuring devices to highly specialized impedance or voltage analyzing equipment. The frequency range used in eddy current equipment ranges from a few cycles per second to several megacycles. Excitation wave form may be either sinusoidal, single pulse, or repetitive pulse type.<sup>2</sup>

### 8.1.3.3 Instrument Arrangements<sup>2</sup>

Block diagrams of some representative types of eddy current instruments are shown in Fig. 3.

The impedance of the test coil can be used to control the operating frequency and amplitude of oscillation of an oscillator as shown in Fig. 3 (a). The detector may monitor frequency or amplitude, and the oscillator may be tuned to discriminate against small changes in a single test variable such as test coil to object spacing, test specimen diameter or other undesired effects. This type of instrument can be made very sensitive.

The generator with amplitude detector shown in Fig. 3 (b) is a simple and useful device. The test coil may be tuned as shown to increase sensitivity and to give discrimination against a particular undesired test condition, or may be left untuned. A compensating or balance circuit may be added between the test coil and amplifier to give effective control of the signal presented to the amplitude detector which permits the application of phase discrimination. A simpler version of this arrangement is possible by elimination of the amplifier, placing the detector in the output of the test coil system.

The main sections of an amplitude-phase detector type eddy current testing device are shown in the block diagram in Fig. 3 (c). Here, a generator supplies excitation for the test coils, a balance unit provides an adjustable signal which is combined with the test coil signal output to give a null or near null signal input to the amplifier. The amplitude-phase detector serves to suppress signals having a particular phase angle which is selected by the phase adjust circuit. The output of the detector drives a readout circuit which may consist of meters, cathode ray oscilloscope, or recorder. Some instruments are provided with automatic audible alarms with adjustable level control, and with automatic reject relay or marker circuits.

#### 8.1.3.4 Test Coil Arrangements<sup>2</sup>

Several test coil arrangements used in rod and tubing tests are shown in Fig. 4. A single primary type coil is shown in Fig. 4 (a), and a double coil having a primary exciting winding and a secondary sensing winding is shown in Fig. 4 (b). These types of coils are often used for conductivity and wall thickness measurements. In contrast, a differential coil connection is shown in Fig. 4 (c) in which the coils are connected in electrical opposition. Here, one section of the test object is compared with an adjacent section. With this arrangement the effects of slowly varying changes along the rod or tube are cancelled, and the response is greatest to abrupt changes in condition along the test object. The differential connection is used for the detection of short cracks, or other local irregularities, or the detection of abrupt ends of long, uniform cracks. Test coils connected in a bridge circuit are shown in Fig. 4 (d). Here, the test object is compared with a standard object placed in a second coil.

#### 8.1.3.5 Instrument Output Display Methods<sup>2</sup>

Instrument outputs are commonly displayed on meters, cathode ray oscilloscope, or direct writing oscilloscopes. Three main types of cathode ray displays are linear time base, the elliptical pattern, and the vector point or vectorscope presentation. In the linear time base display, the instrument output carrier or demodulated carrier is applied as a vertical deflection signal, resulting in defect signals displayed along the time base as they are received. The elliptical pattern is obtained by applying the test signal carrier to the vertical deflection system and a reference carrier to the horizontal system. Amplitude and phase changes of the signal carrier can be distinguished by changes in the shape and tilt of the ellipse. The vectorscope presentation displays the test coil impedance or voltage output on a plane so that characteristic test coil impedance loci can be directly observed and related to theory and calibration tests using known standards.

Scanning techniques are closely allied with display methods. Two scanning methods are shown in Fig. 5. In one a cylindrical surface is scanned with a probe type coil. In the other a tube is scanned with an encircling coil. In each case the instrument output can be displayed using an oscilloscope or recorded with a linear time base which can be calibrated and synchronized with the rotation and translation of the test object, making it possible to relate sections of the record with corresponding areas of the test object.

8.1.3.6 Standard Specifications Covering the Eddy Current Test

ASTM A249-61T, "Welded Austenitic Steel Boiler, Superheater, Heat-Exchanger, and Condenser Tubes," permits, when accepted by the purchaser, the use of the eddy current test as an alternate to the hydrostatic test. ASTM A450-61T, "General Requirements for Carbon, Ferritic Alloy, and Austenitic Alloy Steel Tubes," contains the following statement regarding eddy current testing:

Each tube shall be tested at the mill by passing it through a nondestructive tester capable of detecting any defect that completely penetrates the tube wall or any defect equal to or greater than specified (in the table below). Such tests shall be made on the welded seam and the adjacent metal affected thereby, or on the entire cross section of the tube, at the option of the manufacturer.

In.	Wall Thickness*		Minor Dimension (Least Dimension) of the Defect, Length or Depth	Defective Area, (Length x Radial Depth), Sq.In.
	Birmingham Wire	gage		
0.035	20		0.006 in.	0.0025
0.049	18		0.006 in.	0.0030
0.065	16		12½% of wall	0.0030
0.083	14		" " "	0.0040
0.095	13		" " "	0.0040
0.109 and over	12 and heavier		" " "	0.0050

\*For intermediate wall thicknesses, the next lower wall thickness shown in the table shall apply.

### 8.1.3.7 - 8.1.3.8

#### 8.1.3.7 Standards for Eddy Current Tests

One of the problems with eddy current testing has been the lack of a suitable standard for determining the sensitivity of an eddy current tester for detecting defects in a particular tube size and composition. Notches made by conventional machining methods have several disadvantages: (1) they cold work the material locally, causing a change in magnetic properties, (2) they are dimensionally different from natural defects such as cracks and splits, (3) they are very difficult to produce on inside surfaces of tubes, and (4) they are difficult to produce to precise dimensions.

As a result, some tube manufacturers find it difficult to detect notches made by conventional methods to the ASTM depth requirements given in Par. 8.1.3.6 although they have observed that in practice their eddy current test equipment will detect actual defects considerably shallower than the artificial notches. When the sensitivity of the eddy current tester is increased so that the artificial notch is detected, signals from harmless imperfections, cold worked areas and slight dimensional changes cause much tubing to be rejected that is suitable in quality to meet the purchaser's specification. Some tube mills use tubes containing small diameter drilled holes as their standards for adjusting machine sensitivity. It is difficult to correlate the response from a drilled hole with that of a natural defect.

The nearest approach to ideal artificial defects are the notches produced by spark machining on a device developed by Trent Tube Company. The device is described in the article "A Standard for Eddy Current Tests" by H. J. Bowman, Metal Progress, July 1962. With this device, narrow notches of accurately controlled depth can be made on the I.D. or O.D. of tubes of practically all metallic materials. The metal adjacent to the notch is free from metallurgical changes such as cold work or heat effects. The response to such notches by an eddy current tester should approach that caused by a natural defect of the same depth.

#### 8.1.3.8 Application in Tube Mills

Most tube mills that manufacture welded stainless steel tubing now possess one of the several types of eddy current testers that are available for use in testing full finished tubing on a production line basis. The method is not universally used in the seamless tube industry, where ultrasonic testing seems to be favored. Many welded tubing manufacturers will eddy current test full finished tubing, even though the purchaser has not specified such testing, as a rapid method of finding serious defects such as cracks or splits. The equipment sensitivity in such cases probably would not be set as high as when the test is specified by a purchaser. Welded tube mills will eddy current test to ASTM requirements at no cost to the purchaser as a substitute for the hydrostatic test.

In welded tubing mills where there is experience in eddy current testing, the manufacturing methods are chosen that will cause the least amount of difficulty in the subsequent testing operations. For example, a tube mill might choose to make the final tube drawing operation a "plug draw" rather than a "bar draw" because previous experience has indicated that the "reeling" operation required to release the bar from inside the tube after bar drawing produces very small grooves in the tube surface which are detected by the eddy current tester. Other mills have found that an O.D. polishing operation is necessary to remove minor ripples from the surface and as the result give a better eddy current test acceptance rate.

The type of equipment used by the different mills ranges from rather simple single frequency types to complicated multi-frequency types which enable the user to obtain better sensitivity for surface or subsurface defects, and types which enable the user to filter out the undesirable signals resulting from minor surface ripples or from areas of cold work while retaining the signals from actual imperfections such as cracks, splits, laps, etc. It will be found that some mills have a great amount of "know-how" about eddy current theory and equipment, while others rely primarily on the equipment manufacturer's instructions.

The size range for inspection by the eddy current test method ranges from the smallest tubing sizes produced to about 3 in. O.D. maximum with walls 1/2 inch thick. In addition to detecting cracks, seams, and splits, the method will show cold worked areas, dents, gouges, inclusions, carburized areas, corroded areas, laps, and certain types of deposits on the inside of the tubing. As the result, it is frequently difficult to find an open defect on tubing which has been rejected, and evaluation programs are sometimes required (including evaluation by other nondestructive testing methods) to permit acceptance of tubing which has been rejected by the eddy current test.

#### 8.1.3.9 Advantages and Disadvantages

##### a. Advantages

1. Testing speed is high (over 100 ft. per min.) making it suitable for routine tests on a production line basis.
2. The test method is highly sensitive to cracks or crack-like defects.

### 8.1.3.9

3. The test method with suitable modifications can be used on both magnetic and nonmagnetic metallic materials.
4. The test equipment used can be instrumented to mark defect locations on the tubing in addition to flashing a light and/or giving an audible signal when a defective tube is encountered - the test thereby not being dependent on the inspector's judgment.
5. Outside surface, inside surface, and subsurface defects can be detected.
6. The test is suitable for wide range of tube sizes and wall thicknesses up to about 3 in. O.D.

#### b. Disadvantages

1. The test is highly sensitive to cold worked areas and dimensional changes. These may cause rejections of good quality tubing.
2. No universally accepted standard is available for determining testing machine sensitivity for a given tube material and size.
3. Only full finished tubing is suitable for testing since dimensional changes and different degrees of cold work may cause needless rejections.
4. Tube manufacturing processes must be chosen to minimize ripples and cold worked areas. Polishing is often necessary to remove surface blemishes.
5. Equipment cost is high.
6. Method is not necessarily suitable as an inspection tool for use by the purchaser of tubing since tubing which was not produced to meet eddy current test requirement, although free from harmful imperfections, will have a high reject rate.

8.1.3.10 Sources of Information

1. Libby, H. L., "Basic Principles and Techniques of Eddy Current Testing", Nondestructive Testing, Nov.-Dec. 1956.
2. Libby, H. L., "Evaluation and Inspection of Materials by Use of Eddy Currents", Preprint Paper No. 21, 1962 Nuclear Congress, New York, New York, June 1962, American Society for Testing Materials.
3. Grieve, J. R., and Bounds, A. M., "Nondestructive Testing of Small Tubing", Metal Progress, Dec. 1960.

**FIGURE 1**  
**BASIC EDDY CURRENT TEST ARRANGEMENTS**

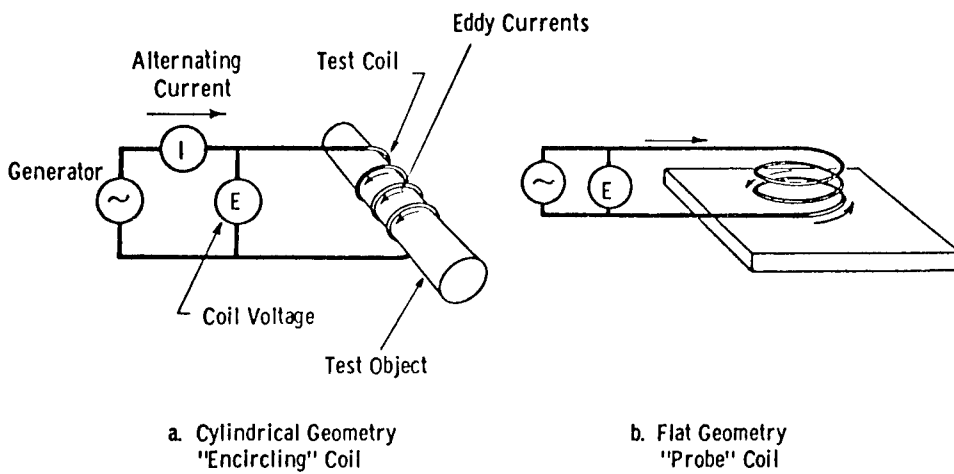

**FIGURE 2**  
**CURRENT AND ENERGY RELATIONSHIPS IN A BASIC EDDY CURRENT TEST**

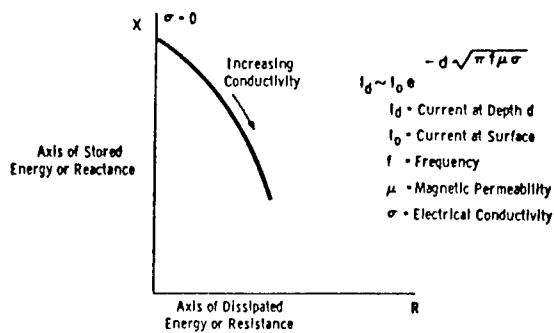
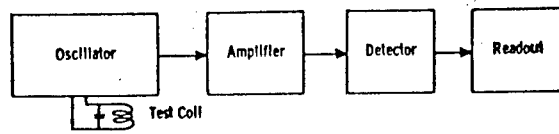
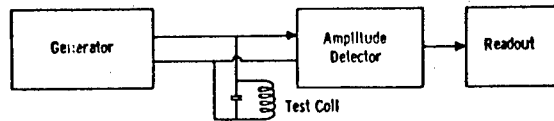

FIGURE 3  
TYPICAL EDDY CURRENT INSTRUMENTS



a. Oscillator Tuned by Test Coil



b. Fixed Generator with Amplitude Detector

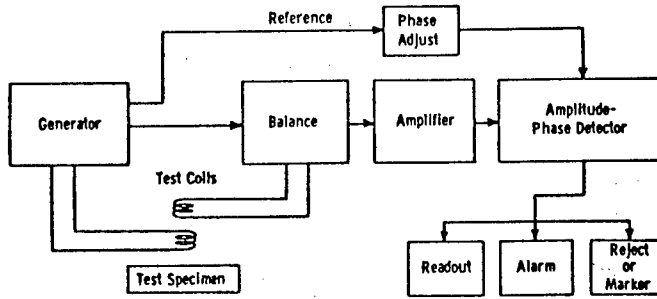

c. Fixed Generator with Amplitude - Phase Detector

FIGURE 4  
ENCIRCLING TEST COIL ARRANGEMENTS

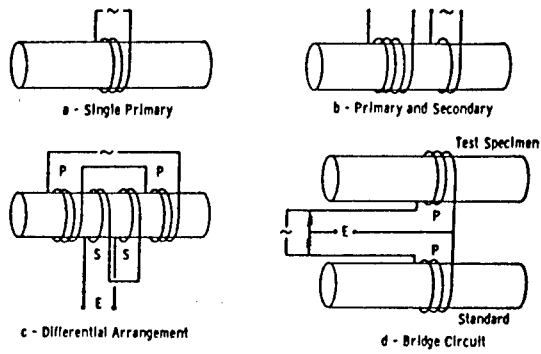
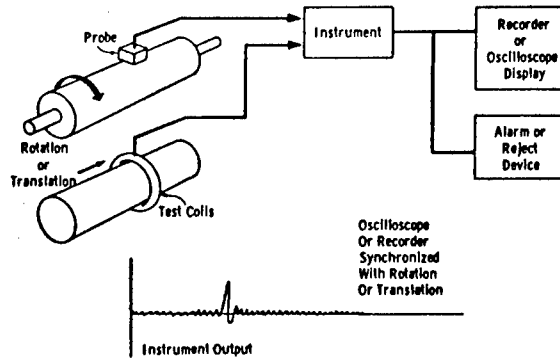

FIGURE 5  
SCANNING TECHNIQUE



## 8.1.4 Liquid Penetrant Inspection

### 8.1.4.1 General

Liquid penetrant processes are nondestructive testing methods for detecting discontinuities that are open to the surface. They can be used effectively in the inspection of nonporous metallic materials, both ferrous and nonferrous, and on nonporous non-metallic materials such as ceramics, plastics, and glass.

Surface discontinuities such as cracks, seams, laps, porosity, laminations, or lack of bond are indicated by these methods.

In all of the penetrant methods, the liquids used enter small openings such as cracks, fissures, and tube-like passages by capillary action. The rate and extent of this action are dependent upon such conditions as surface tension, cohesion, adhesion, and viscosity. It is also influenced by other factors such as time, and condition of the surface of the material and of the interior of the discontinuity.

In using any liquid penetrant inspection method, it is very essential that the surface of the material be thoroughly cleaned of all foreign matter that would obstruct the entrance of the liquid into the discontinuity. After the cleaning operation, the liquid penetrant is applied evenly over the surface to be inspected and allowed to remain on it a sufficient length of time to permit penetration into possible discontinuities. The liquid is then completely removed from the surfaces being inspected and a developer applied to them. The liquid penetrant that has entered the discontinuities will then begin to seep or bleed out onto the surfaces, and the blotting action of the developer will help delineate the discontinuity. This will indicate the presence, location, and, in general, the nature and magnitude of the discontinuities present. Depending on the type of penetrant test used (as described in Par. 8.1.4.2 and 8.1.4.3) the observation is visual with the unaided eye or by means of "black light".

Information in paragraphs 8.1.4.1, 8.1.4.2, and 8.1.4.3 was taken from ASTM Specification E 165-60T, "Tentative Methods for Liquid Penetrant Inspection".

### 8.1.4.2 Fluorescent Penetrant Inspection Method

There are three variations of the fluorescent penetrant method. A representative fluorescent penetrant material is "Zyglo", manufactured by Magnaflux Corporation. Fig. 1 gives a diagrammatical description of the fluorescent penetrant testing procedure.

Details of the three procedures are listed below:

a. Procedure A-1, Fluorescent Water Washable Penetrant.

- (1) Penetrant Application. After the part has been cleaned by a detergent, solvent, or other suitable method to remove from the surface any rust, scale, welding flux, spatter, grease, paint, oily films and dirt, which might interfere with penetrant inspection, the penetrant is applied to the part by brushing, spraying, or dipping. After the penetrant is applied, a period of time must elapse to allow the penetrant to enter any discontinuities that may be present. It is not necessary that the part be submerged in the penetrant during this penetration time since the penetrant will fill discontinuities by capillary action.

The length of the penetration time depends upon the material being inspected, the processes through which it has passed, and the type of discontinuities expected. Table 1 gives suggested penetration times for typical discontinuities in a variety of materials.

- (2) Rinsing. After a suitable penetration time, the surface film of penetrant on the part is removed by a water rinse. This rinsing must be complete and thorough so that the only penetrant remaining will be within the discontinuities of the part. Drilled holes and threads should be thoroughly rinsed. Surface scratches and shallow blemishes will wash clean. A suitable spray nozzle should be used for the rinse operation since the penetrant is more completely emulsified by the physical action of the water droplets.

There is danger that hot water may remove some penetrant from the larger or more shallow discontinuities. This problem is minimized by keeping the rinse water temperature below 110°F.

A "black light" is used to check the part after rinsing to insure that the rinsing operation is complete and all surface penetrant has been removed.

- (3) Developing. After washing the part to remove the penetrant from the surface, a developer is applied to draw or blot the penetrant in discontinuities to the surface. Either a wet developer or a dry developer can be used to bring out the full brilliance of the indications. The use of the dry developer

results in the utmost in sensitivity and brilliance and is recommended for use on parts, the function of which is considered to be of a critical nature. The dry developing powder is more easily removed than the wet developer.

The coating of developer, either wet or dry, is not in itself fluorescent, but is dark when viewed under black light. It acts to subdue background fluorescence on parts and causes discontinuities to show up with a high degree of contrast.

Wet developer is purchased as a dry powder which is then mixed with water to form a liquid suspension. Parts to be treated with the wet developer are dipped in the solution immediately after rinsing, or applied with brush or spray and are then dried with hot air. A film of powder dries out upon the part and develops indications.

When dry developer is used, the part to be treated is first dried following the rinsing operation. The developer is applied with a hand powder bulb, powder gun, or soft brush. Excess powder may be knocked off by shaking or tapping the part gently, or blowing off with low pressure compressed air.

A developing time should be allowed before inspecting the part to allow the developer to draw back to the surface penetrant that may be in the discontinuities. The developing time should be at least half the time allowed for penetration. Excessively long developing time may cause the penetrant in large deep discontinuities to bleed back, causing a broad, smudgy indication.

- (4) Inspection. After the development of indications, the parts are inspected with a high intensity "black light" in a darkened area or booth. A portable hand lamp should be used over the surface of large parts. Small parts are more conveniently held under a fixed light. So-called "black light" has a wave length of 3650Å. This light is between the visible and the ultraviolet in the spectrum. Light in this range is considered noninjurious to the skin and eyes.

The indications, when viewed under "black light", will fluoresce brilliantly, and the extent of the indication marks the extent of the opening of the discontinuity on the surface. Pores will show as

8.1.4.2a - 8.1.4.2b

glowing spots, while cracks will show as fluorescent lines. Where a large discontinuity has trapped a quantity of penetrant, the indications will spread on the surface. Experience in the use of the method allows interpretation to be drawn from the extent of this spread as to the relative size of the discontinuities. For best results, inspections should be made in a darkened area. The darker the area, the more brilliant the indications will show. This is extremely important when looking for very fine indications.

b. Procedure A-2, Fluorescent Post Emulsified Penetrant.

- (1) General. With the post emulsified procedure, the penetrating material is not water-washable. Emulsifier is applied as a separate step in the procedure. It is particularly effective in detecting shallow crack like surface blemishes from which a water-washable penetrant might be removed.
- (2) Penetrant Application. Same as described for Procedure A-1, except that recommended penetration times are given in Table 2.
- (3) Emulsification. In the post emulsified procedure there is an additional step before the part is ready for inspection. Since the penetrant is not water washable as applied on the part, it is necessary to apply an emulsifier to the part after the penetration time. The emulsifier combines with the surface penetrant and makes the mixture of penetrant and emulsifier removable by water. The emulsifier is applied by dipping the part into it or by flowing or spraying it on the part.

The length of time that the emulsifier is allowed to remain on the part is critical, particularly for detecting shallow scratch-like discontinuities. For highest sensitivity to shallow discontinuities, this length of time should be held at the minimum that will just give a good water wash. The length of time that the emulsifier remains on the part is not critical when only tight, deep cracks are sought, as long as a clean wash is obtained.

- (4) Rinsing. After the emulsification period, the surface film of penetrant and emulsifier is removed from the part with a forceful water stream. Rinsing should be

carried out under a "black light" to insure complete cleaning of all surfaces.

Rough surface conditions may prevent the emulsifier from combining with the penetrant and thus reduce the washability in such areas. It may prevent the use of Procedure A-2 on parts having exceptionally rough surfaces, blind holes, and threaded parts.

- (5) Developing, Drying, and Inspection. Developing, drying, and inspection are the same as specified for the fluorescent, water-washable material in Procedure A-1.

c. Procedure A-3, Fluorescent Solvent Removable Penetrant

- (1) Penetrant Application. Penetration times for solvent removable fluorescent penetrant are as shown in Table 2. Apply the penetrant as specified in Procedures A-1 and A-2. Since this system is usually selected for its portability, or for checking restricted areas, the penetrant is often applied from aerosol-type pressure cans.
- (2) Penetrant Removal. After adequate penetration time, excess penetrant is removed by spraying the surface with a suitable solvent and wiping it promptly with a clean cloth. If too much solvent is used it is possible to remove fluorescent material from the indications. After removal of surface penetrant, examine the surface with a "black light" to insure that satisfactory cleaning has been accomplished. Excess material left on the surface will cause a fluorescent background after development which will interfere with observation of the indications.
- (3) Developing. With Procedure A-3 a solvent-base wet developer is usually used. Since the solvent evaporates rapidly, leaving a uniform film of developer on the surface, no additional drying step is necessary. For portable applications the developer can be applied from aerosol-type pressure cans. Water-base or dry developers could be used as specified in Procedure A-1.
- (4) Inspection. Parts are inspected as described for Procedure A-1. Procedure A-3 is often used when it is necessary to perform an inspection out of doors. If high brilliance fluorescent penetrants are used, this can be accomplished by shading the area being inspected.

8.1.4.3 Visible Dye Penetrant Inspection Method

a. General

Visible dye penetrant inspection makes use of a penetrant that can easily be seen in daylight or with visible light. The penetrant is usually deep red in color so that the indications produce a definite red color as contrasted to the white background of the developer. The sensitivity of this process depends principally on the same conditions as for fluorescent penetrants. A representative visible dye penetrant material is "Dy-Chek", manufactured by Turco Products, Inc.

b. Visible Dye Penetrant Procedures

Three general procedures are used in visible dye penetrant inspection:

- (1) Procedure B-1, Visible Water Washable. This makes use of a visible penetrant that is water-washable. The general processes are similar to Procedure A-1, Fluorescent Water-Washable Penetrant. This is a simpler process but considered not as accurate as Procedure B-2 below because water can remove penetrant from the discontinuities.
- (2) Procedure B-2, Visible Post Emulsified. This visible dye inspection method utilizes a red dye contained in a highly penetrating solvent that seeks out and fills surface cracks, porosity and discontinuities. The excess dye penetrant, which is not water-rinsable, is then removed by applying the emulsifier which converts the penetrant to a water-rinsable emulsion.
- (3) Procedure B-3, Visible Solvent Removable. In this case, the penetrant is not water-washable, and excesses are removed from the surface by means of a recommended solvent. (This is the procedure that has been used at Savannah River Plant.)

c. Penetrant Application

After parts have been cleaned with a solvent or by other suitable methods to remove all foreign material that would prevent the penetrant from entering discontinuities, or which would prevent excess penetrant from being removed from the surface, and the parts have been thoroughly dried, the penetrant is applied. The size, shape, and number of articles to be inspected will determine whether

the spray, brushing, or dipping method should be employed. If only certain critical areas (such as welds) are to be inspected, application by brush or spray will reduce consumption of the penetrant, and will also facilitate penetrant removal.

An approximation of the penetration time can be obtained from Tables 1 and 2. Experience may indicate that longer or shorter penetration times are necessary for detection of specific types of defects such as cracks in welds.

The process is designed for use at temperatures between 60 and 90°F. and should be used within this temperature range whenever possible.

d. Penetrant Removal

The method of penetrant removal depends on the type of penetrant used. Procedures B-1 and B-3 use penetrants that can be removed with a water and solvent rinse, respectively, and do not require rinsing aids known as removers or emulsifiers. This results in eliminating one operation and one material from the complete procedure. Accordingly, it can be said that Procedures B-1 and B-3 are simpler, but these two systems may also be less accurate than Procedure B-2 because the penetrant can be removed from the voids during the rinsing operation.

- (1) Procedure B-1, Water Washable. The water-washable penetrant is flushed from the external surfaces by spraying with water. Standard water line pressure will provide adequate rinsing. Rinse until no visible evidence of red dye remains on the surface. Over-rinsing should be avoided to prevent removal of penetrant from discontinuities.
- (2) Procedure B-2, Post Emulsified. The emulsifier is applied to the area covered by the penetrant by brushing, flowing, or dipping. The mixture of emulsifier and penetrant is flushed from the surface with a water spray. It is essential that all penetrant be removed from the surface and that none of the penetrant be removed from the discontinuities themselves. The post emulsified method has been designed with these two major points in mind.
- (3) Procedure B-3, Solvent Removable. The penetrant is flushed off the surface by careful rinsing with a solvent. The part may be wiped with clean rags or

towels after application of the penetrant, or the cleaning may be accomplished with rags or towels that have been soaked with solvent. Regardless of the cleaning method used, it is important to remove all traces of penetrant from the surface since residual penetrant will bleed through the developer and may mask or be confused with the areas where penetrant is bleeding from discontinuities. Non-flammable solvents used for penetrant removal are chlorinated hydrocarbons. For applications where a chloride free solvent is required, such are available, but are flammable.

e. Drying

When solvent-type cleaners have been used to remove the penetrant, drying is accomplished by evaporation at room temperature. If a water rinse has been used to remove the penetrant, drying is generally accomplished by placing the parts in a heated drier for a period of time sufficient to insure adequate surface drying only. Drying temperature should be maintained between 160° to 200°F. For field applications drying could be accomplished by use of heat lamps or by blowing hot air on the part. Prolonged heating tends to dry the penetrant in discontinuities which may be present.

f. Developing

There are two reasons for applying the developer to the parts: the film of developer on the parts furnishes a white coating which serves as a contrasting background for the visible dye penetrant, and the liquid vehicle in the developer draws the penetrant from the discontinuities to the surface of the developer film, thus revealing discontinuities.

After excess penetrant has been removed and parts have been thoroughly dried, a thin, even coating of developer is sprayed or swabbed on the area being inspected. The developer is a liquid suspension of a powdered material. The layer of developer when dried on the surface of the part should be white. If the parts have a pink hue, it indicates that residual penetrant has been left on the surfaces. The parts should be re-cleaned and the developer applied again.

g. Interpretation of Test Results

As the developer dries to a smooth, even, white coating, red indications will appear at locations of discontinuities. Depth of surface discontinuities may be correlated with the richness of color and speed of bleed-out.

Usually, a crack or similar opening will show a red line. Tight cracks or a partially welded lap will show a broken line. Gross porosity may produce large indications covering an entire area. Very fine porosity is indicated by random red dots.

Since red flaw indications will remain visible until wiped off manually, there is no need to rework defective parts immediately. In fact, if salvage is practical, parts can often be reworked with the location and extent of discontinuities still showing.

8.1.4.4 Applications

The visible dye penetrant method has enjoyed wide usage for inspection in shop and field fabrication work at Savannah River Plant and in field repair of equipment. It has also been specified as an inspection method for use in vendor's shops to check equipment being fabricated for Savannah River Plant. Very little usage has been made of the fluorescent penetrant method although many of the applications where the dye penetrant method was used could have been handled equally well by the fluorescent penetrant method. One of the primary reasons for favoring the dye penetrant method is that inspections are frequently required on localized areas of large equipment items under shop or field conditions where the use of a "black light" would be difficult.

Some typical applications for the dye penetrant method are listed below:

- a. To check the surfaces of welds in stainless steel equipment for the presence of cracks, porosity or other defects.
- b. To check the effectiveness of back chipping operations in the fabrication of welded stainless steel equipment.
- c. To determine if defects have been completely removed in the repair of defective welds.
- d. To determine if defects exist in large areas of overlay welding - such as found in power reactor applications.

#### 8.1.4.4 - 8.1.4.5

- e. To determine if defects such as cracks, laps, etc. are present on the surface of stainless steel castings.
- f. To determine if surface defects are present in wrought stainless steel items of small to moderate size, including pipe, tubing, forgings, etc.
- g. To determine if known defects completely penetrate a weld or to determine location of a leak. (In this case, the penetrant is applied on one surface of a tube or vessel wall and the developer on the opposite wall. If there is a leak, the penetrant will show on the developer.)
- h. To check the surface of equipment items which have been operated to determine if cracks (such as caused by stress corrosion cracking) are present. The effectiveness of this application will depend on the degree to which the equipment item can be cleaned.

#### 8.1.4.5 Acceptance Standards

There are no generally accepted standards which can be used for interpretation of results of the penetrant tests. Definite cracks are rejectable regardless of the item which is being inspected. In the case of welds, lack of fusion, incomplete penetration and other linear defects are cause for rejection. For defects which are not linear, such as porosity and small slag pockets, it becomes difficult to set forth rules for acceptance since a small number of such defects are permitted by the ASME Code when they are detected by radiographic examination.

With regard to small non-linear defects, listed below are excerpts from penetrant testing specifications from two large manufacturers of nuclear power equipment:

- (1) In any 6" length of weld, there shall be no indications greater than 1/16" dia., nor shall there be more than 6 indications the sum of whose diameters is greater than 3x the maximum diameter specified above. Indications of pinpoint porosity may be permitted if well dispersed, and if the pattern formed does not indicate that they are linearly disposed so as to promote formation of a crack or other continuous defect under stress. In no case shall the center-to-center distance between any two indications be less than 3/16".

- (2) In any 4 inch diameter circular area or  $3\frac{1}{2}$  sq.in. area of weld surface examined, there shall be no indications greater than  $1/16$ " dia., as revealed by fluorescent penetrant examination, or  $3/32$ " dia. as revealed by dye penetrant, nor shall there be more than 6 indications, the sum of whose diameters is greater than 3x the maximum diameter specified herein. Indications of pin point porosity may be permitted if well disposed, and if the pattern formed does not indicate that they are linearly disposed so as to promote formation of a crack or other continuous defect.

Fig. 1 Diagrammatical Description of  
Fluorescent Penetrant Testing Procedure

(From Magnaflux Corp. Bulletin  
"Zyglo & Zyglo-Pentrex Fluorescent  
Penetrant Testing")

- (a) Clean surface thoroughly.
- (b) Apply penetrant to surface.

**PENETRATION**

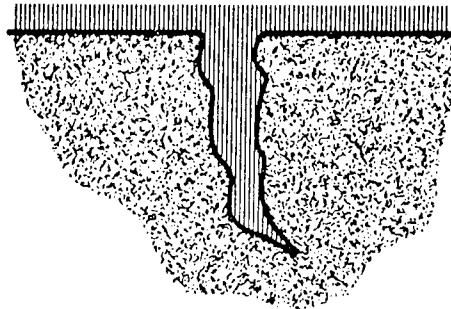

*Fluorescent penetrant on surface seeps into crack.*

(Optional) Apply emulsifier over penetrant.

**EMULSIFICATION**

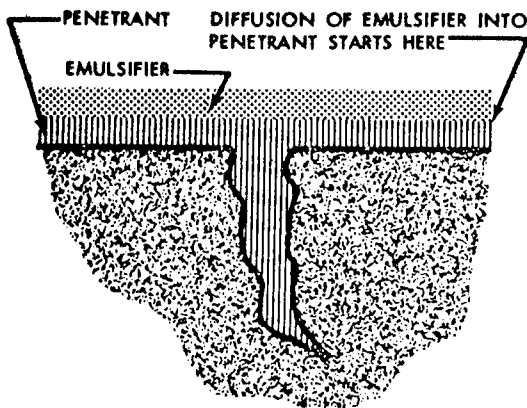

*Emulsifier applied to penetrant.*

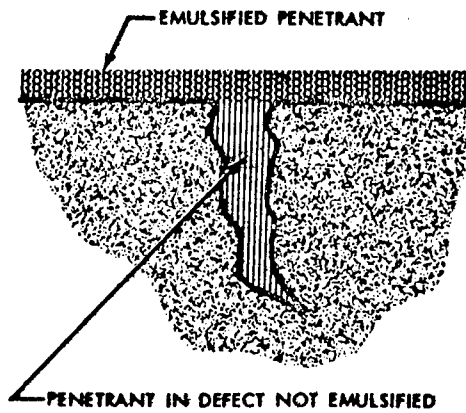

*Penetrant on surface and emulsifier are mixed.*

Rinse with water:

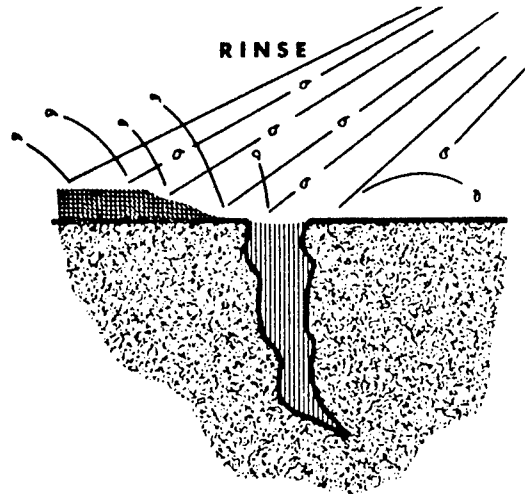

*Water spray removes penetrant from surface but not from cracks and pores.*

Apply developer to surface:

**DEVELOPMENT**

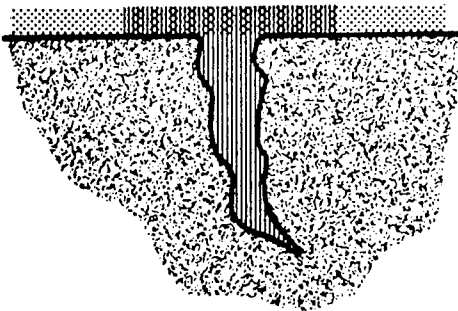

*Developer acts like a blotter to draw penetrant out of crack.*

Inspect surface with black light:

**INSPECTION**

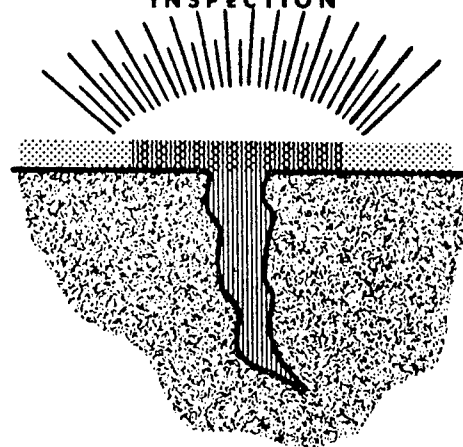

*Black light causes penetrant to glow in dark.*

**TABLE I.—SUGGESTED PENETRATION TIME FOR WATER-WASHABLE  
PENETRANTS.  
Procedures A-1 and B-1**

Material	Form	Type of Discontinuity	Penetration Time, min
Aluminum	Castings	Porosity	5 to 15
	Extrusions and Forgings	Cold Shuts	5 to 15
		Laps	30
	Welds	Lack of Fusion	30
Magnesium	Castings	Porosity	15
	Extrusions and Forgings	Cold Shuts	15
		Laps	30
	Welds	Lack of Fusion	30
Steel	Castings	Porosity	30
	Extrusions and Forgings	Cold Shuts	30
		Laps	60
	Welds	Lack of Fusion	60
Brass and Bronze	Castings	Porosity	10
	Extrusions and Forgings	Cold Shuts	10
		Laps	30
	Brazed Parts	Lack of Fusion	15
Plastics	Castings	Porosity	15
	Extrusions and Forgings	Porosity	15
		Laps	30
	Welds	Cracks	30
Glass	All Forms	Cracks	5 to 30
		Cracks	5 to 30
Carbide-Tipped Tools	All Forms	Lack of Fusion	30
		Porosity	30
		Cracks	10
Titanium and High-Temperature Alloys	All	Use Procedure A-2 (Table II)	

TABLE II.—SUGGESTED PENETRATION TIME FOR POST EMULSIFIED  
AND SOLVENT REMOVABLE PENETRANTS.  
Procedures A-2, A-3, B-2, B-3

Material	Form	Type of Discontinuity	Penetration Time, min
Aluminum	Castings	Porosity	5
		Cold Shuts	5
	Extrusions and Forgings Welds	Laps	10
		Lack of Fusion	5
All Forms	Porosity	5	
	Cracks	10	
Magnesium	Castings	Porosity	5
		Cold Shuts	5
	Extrusions and Forgings Welds	Laps	10
		Lack of Fusion	10
All Forms	Porosity	10	
	Cracks	10	
Steel	Castings	Porosity	10
		Cold Shuts	10
	Extrusions and Forgings Welds	Laps	10
		Lack of Fusion	20
All Forms	Porosity	20	
	Cracks	20	
Brass and Bronze	Castings	Porosity	5
		Cold Shuts	5
	Extrusions and Forgings Braze Parts	Laps	10
		Lack of Fusion	10
All Forms	Porosity	10	
	Cracks	10	
Plastics	All Forms	Cracks	5
Glass	All Forms	Cracks	5
Carbide-Tipped Tools		Lack of Fusion	5
		Porosity	5
		Cracks	20
Titanium and High-Tem- perature Alloys	All		20 to 30

8.1.5 - 8.1.5.2

## 8.1.5 MAGNETIC PARTICLE INSPECTION

### 8.1.5.1 Definition<sup>1</sup>

Magnetic particle inspection is a non-destructive method for detecting cracks and other discontinuities at or near the surface in ferromagnetic materials. Finely divided magnetic particles are applied to the surface of a part which has been suitably magnetized. The particles are attracted to regions of magnetic non-uniformity associated with defects and discontinuities, thus producing indications which are observed visually. This inspection method is commonly known as "Magnaflux" inspection after the name applied to such equipment by Magnaflux Corporation. There are other manufacturers of similar equipment.

### 8.1.5.2 Principles of Operation<sup>2</sup>

The magnetic particle method depends for its operation on basic magnetic principles. If a crack, or other crack-like discontinuity in a magnetized piece of ferromagnetic material is so located as to be transverse to the direction of the magnetic field in the material, that field is distorted. The flux lines are crowded or deflected around the ends of such a magnetic obstruction. If the obstruction lies near enough to the surface of the material, some of these flux lines will be crowded outside the surface of the material, and a "leakage field" is produced at the surface over the discontinuity. The closer the discontinuity is to the surface, the stronger the leakage field, and in the case of a surface crack, the field is quite strong and highly localized.

If a powder of fine particles of a magnetic material, either dry or suspended in a liquid, is applied over the surface in the vicinity of a leakage field, some of the powder will be attracted and held by the leakage field and will set up a magnetically held pattern outlining the discontinuity. See Figure 1.

The greater the obstruction in the magnetic path, the stronger the leakage field. Sharp, deep cracks at right angles to the surface give the strongest patterns; and large discontinuities below the surface having their principal dimension at 90° to the surface are the most favorable conditions for producing strong surface indications. Small defects or defects of unfavorable shape must be close to the surface to be found. Surface scratches and tool marks produce indications only at high levels of magnetization.

From the above, two fundamental points are apparent:

- a. Given a part containing discontinuities, it is necessary in order to produce good leakage fields, to magnetize the part in such a way that the resulting field will cross the discontinuities.

- b. The strength of the leakage field, and hence the strength of the powder pattern produced, will vary with the intensity of the magnetization set up in the part.

Choice of magnetizing current affects sensitivity. A.C., because of skin effect, magnetizes the surface layers of the material more strongly than those deeper in the part. D.C. gives a more uniform field intensity over the entire cross section. Thus, if the inspection is for surface cracks only, A.C. gives maximum sensitivity, while D.C. gives greatest sensitivity for the location of subsurface discontinuities. For purposes of magnetic particle inspection, rectified A.C. gives the same results as D.C.

### 8.1.5.3 Applications

Since magnetic particle inspection is suitable only for use on ferromagnetic materials, it cannot be used on most of the stainless steel equipment at Savannah River Plant because of the heavy usage of the austenitic stainless steels for major items. It is suitable, however, for use on any of the 400 series stainless steels and on many of the precipitation hardening stainless steels including 17-4PH in all heat treatment conditions, and 17-7PH, AM350, and AM355 in the solution treated and aged condition. An application where magnetic particle inspection has been used for Savannah River Plant equipment is for the inspection of the 17-4PH racks used for manipulating the control and safety rods for HWCTR.

### 8.1.5.4 Methods<sup>3</sup>

While a part is properly magnetized, the magnetic particles may be applied by one of the following methods:

#### a. Dry Method

In the dry method the particles are applied from a hand shaker, mechanical shaker, bulb blower, or mechanical blower. The powder is applied by dusting it into still air and allowing it to settle evenly on the surface. The color of the dry powder is chosen to provide suitable contrast with the color of the item being inspected.

#### b. Wet Methods

- (1) Oil. The material for the wet method is usually prepared in paste form and the inspection medium is prepared by mixing the paste with a suitable light oil. The recommended liquid for the inspection vehicle is a well refined, light petroleum distillate having a relatively high flash

#### 8.1.5.4 - 8.1.5.5

point. A suspension of from 1 to 2 per cent solid material by volume is generally used. The inspection medium is flowed or sprayed over the area being inspected.

- (2) Water. Magnetic particles suspended in clean water, or clean water with suitable wetting agents may be used. Suspension of from 2 to 2½ per cent solid material by volume is generally used.
- (3) Fluorescent Method. Fluorescent magnetic particle inspection is a variation of the wet method. A paste or powder, similar to that used in the wet method is used, except that the magnetic particles are coated with a material that fluoresces when activated by "black light."

#### 8.1.5.5 Equipment<sup>4</sup>

##### a. Portable Equipment

Approximately 20 standard sizes of portable magnetic-particle inspection equipment are in use. They vary from small hand-held yokes which consist of permanent magnets or electromagnets energized from 115 volt, A.C. lines to large, 10,000 amp., heavy-duty power units used for the inspection of large castings, weldments or forgings. Some portable units which would be of value for use on a large plant are listed below.

- (1) Small magnetizing unit which supplies A.C. magnetizing currents up to 500 amp. for intermittent use when operated from a 115 volt, A.C. line. Parts are magnetized with prods or cable coils. Magnetizing fields are adequate to indicate fatigue and other surface cracks in shafts, beams or machine parts up to several inches in diameter. Dry powder would normally be used with this unit. (This particular piece of equipment can be carried like a suitcase.)
- (2) Medium magnetizing unit which supplies up to 500 amp. of magnetizing current when operated from 115 volt A.C. Both half-wave rectified and A.C. magnetizing currents are available, and the use of either is at the option of the operator. Magnetization can be done by cable coils or through prods. This piece of equipment is in the form of a small cart which could easily be pushed around by one man, and is small enough to fit into the trunk of a car.
- (3) Medium service A.C. and half-wave portable unit which supplies magnetizing currents of 1000 to 2500 amp. Such units are representative of several in the low end of the high current group of heavy

industrial portable units. They are powered by either 220 or 440 volt lines. Where tests are to be made with long leads at distances of 80 to 100 ft. from the unit, the unit supplies only 450 amp. This is usually less than is required for inspection of heavy weldments or castings. Such units could be pushed manually across a floor, but would require a hoist or crane when lifting is required, and would require at least a pickup truck when moving is required.

- (4) Heavy-duty A.C. and half-wave portable unit which supplies magnetizing currents of 3,000 amps., and which provides an automatic demagnetizer. This unit is similar to the one described above except that it can supply higher currents through long leads where large structures are to be inspected at distances of 100 ft. or more from the unit. This unit and the units described in (2) and (3) above would normally be used with the dry powder method.

#### b. Stationary Equipment

Hand-operated, stationary, horizontal wet-method equipment is widely used for testing small manufactured parts. This type probably accounts for about 75% of the magnetic-particle equipment inspection units currently in use in the United States.

Stationary units normally contain a built-in tank with a pump which agitates the wet particle bath and pumps inspection fluid through a hand-held hose for application to test objects. A part is clamped within the magnetizing coil between the copper contact faces of the head and tail stocks. At the operator's option, the parts can be magnetized circularly with current between the heads or longitudinally with current through the coil, or both, if desired. While the part is magnetized, the operator applies the liquid inspection medium and then views the surface for indications. Most units are provided with inspection hood and black lights so that the fluorescent magnetic-particle method can be used.

The stationary units are normally either A.C. or D.C. but not with both in the same machine. A.C. machines are the more common and a typical unit would provide 3,000 amp. maximum magnetization current and would provide for automatic step-down demagnetization.

### 8.1.5.6 Methods of Magnetization<sup>3</sup>

#### a. General

The part being tested may be magnetized either by passing current through the piece or by inducing a

## 8.1.5.6 - 8.1.5.7

magnetic field by means of a central conductor or by coils. Either alternating current or direct current may be used for the detecting of surface indications. Since in circular magnetization the "skin effect" of alternating current reduces the maximum depth at which defects can be found, it is recommended that direct current be used if it is important to detect subsurface defects.

### b. Continuous Method

In the continuous method, the inspection medium is applied to the surface under inspection while the full magnetizing current is still flowing.

### c. Surge Method

In the surge method (direct current only) a high magnetizing force is applied and then reduced to a lower continuous value, which is maintained during application of the inspection medium.

### d. Residual Method

In the residual method the inspection medium is applied to the surface under inspection after the magnetizing current has ceased to flow. The effectiveness of this method depends upon the strength of the magnetizing force and the retentivity of the piece.

### e. Direction of Field

The two general types of magnetization with regard to direction are longitudinal and circular, as follows:

- (1) Longitudinal. When an item is magnetized longitudinally, the magnetic flux lines are usually parallel to the axis of the piece. A longitudinally magnetized piece always has definite poles readily detectable by compass or magnetometer. Longitudinal magnetization is usually accomplished by placing the forging within a solenoid, often formed by wrapping cable around the piece (Fig. 2). For special applications, magnetic yokes, or pole pieces (Fig. 3) are sometimes used.
- (2) Circular. Circular magnetization is obtained by passing a current directly through the piece (Fig. 4), or induced through a conductor or conductors (Figures 5 and 6). Localized circular magnetization may be obtained by passing current through the local areas by use of prod-type contacts (Fig. 7). (Prod-type contacts are widely used for the inspection of welds.)

### 8.1.5.7 Magnetizing Force<sup>3</sup>

The minimum field strength which will reveal and permit classification of all objectionable defects should be used. The

maximum field strengths practical are the ones just below the point at which excessive adherence of the particles begins to occur over the surface being inspected. When circular magnetization is used, the magnetic field strength is directly proportional to the amperage used and inversely proportional to the outside diameter being inspected. When prods are used for circular magnetization of a local area, the field strength is directly proportional to the amperage used, but also varies with the prod spacing and thickness of section being inspected. A magnetizing force of 100 amp. per linear inch is recommended. The field strength induced by a solenoid used for longitudinal magnetization is directly proportional to the ampere turns (product of amperage and number of turns of conductor of solenoid) and varies with the size of the solenoid.

The following table from ASTM E109 suggests current values for various prod spacings.

Prod Spacing, in.	Section Thickness, in.	
	Under 3/4 in.	3/4 in. and over
2" to 4"	200 to 300 amp.	300 to 400 amp.
Over 4" to less than 6"	300 to 400 amp.	400 to 600 amp.
6" to 8"	400 to 600 amp.	600 to 800 amp.

8.1.5.8 Demagnetization<sup>3</sup>

Parts should be sufficiently demagnetized after inspection so that the residual field will not interfere with future machining operations, magnetic instruments used in the proximity of the part, or so that leakage fields will not occur in areas of dynamic contact surfaces.

When direct current is used, demagnetization may usually be accomplished by repeatedly reversing and progressively decreasing the magnetizing current. The initial field strength used during demagnetization should be equal to or greater than the original magnetizing force. When the current has been reduced to the vanishing point, the part should be practically demagnetized. Direct current is recommended for demagnetizing large parts.

When alternating current is used, it is necessary merely to decrease the magnetizing current in small steps or continuously to a very low amperage.

8.1.5.9

8.1.5.9 Standard Specifications

The following ASTM specifications apply to magnetic particle inspection:

- A 275 Magnetic Particle Testing and Inspection of Heavy Steel Forgings
- A 456 Magnetic Particle Inspection of Large Crankshaft Forgings
- E 125 Tentative Reference Photographs for Magnetic Particle Indications on Ferrous Castings
- E 109 Dry Powder Magnetic Particle Inspection
- E 138 Wet Magnetic Particle Inspection

Sources of Information

1. ASTM Specification E109.
2. "Nondestructive Testing of Engineering Materials and Parts," Manual 67, Materials and Methods, (now Materials in Design Engineering), February, 1951.
3. ASTM Specification A275.
4. Nondestructive Testing Handbook, Vol. 2, The Ronald Press Company, New York, New York, 1959.

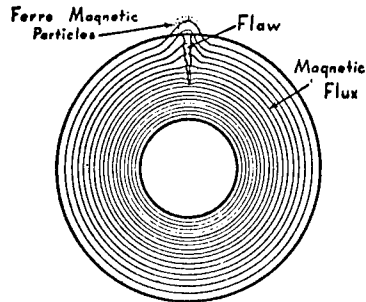

Fig. 1

Schematic sketch shows basic principles of magnetic particle inspection. So-called leakage fields caused by flaws attract and hold iron filings and thus indicate location of flaws.

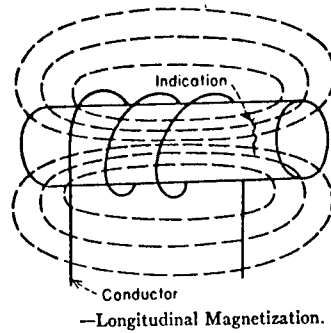

Fig. 2

Conductor  
—Longitudinal Magnetization.

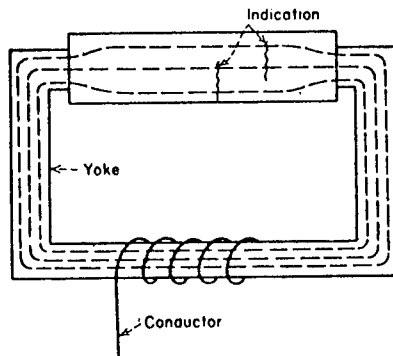
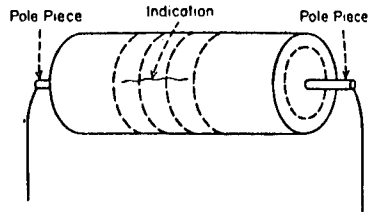

Fig. 3

Conductor  
—Longitudinal Magnetization, with Yoke.

Par. 8.1.5 Figs. 4,5,6, and 7

Fig. 4



-Circular Magnetization, Current Directly Through Forging.

Fig. 5

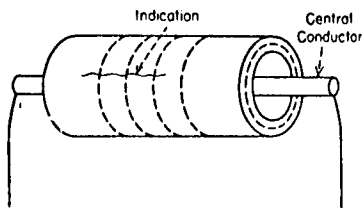

-Circular Magnetization, Current Through a Conductor.

Fig. 6

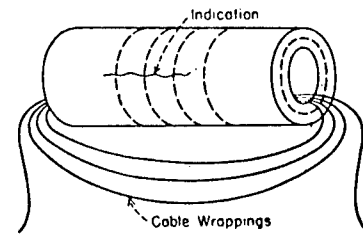

-Circular Magnetization, Current Through Conductors Threaded Through Forging.

Fig. 7

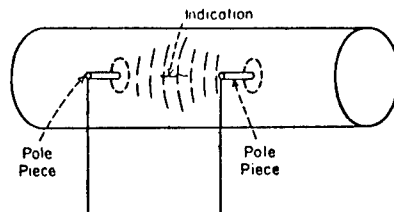

-Circular Magnetization with "Prod" Type Contacts.

## 8.2 DESTRUCTIVE TEST METHODS

### 8.2.1 Corrosion Evaluation

#### 8.2.1.1 General

The methods most commonly employed for corrosion evaluation of the austenitic stainless steels are the boiling nitric acid test and the electrolytic oxalic acid etching method. The sulfuric acid-ferric sulfate test method has largely superceded the boiling nitric acid test within the Du Pont Company. The electrolytic oxalic acid test is extremely sensitive and is used as an acceptance test only, the rejects being re-evaluated by the sulfuric acid-ferric sulfate or the boiling nitric acid test. The latter two tests are for acceptance or rejection. This section will discuss all three tests, commenting on the sensitivity, advantages and shortcomings of each, and listing in a general manner the steps followed in performing the tests.

#### 8.2.1.2 Boiling Nitric Acid Test

##### a. General

The boiling 65% nitric acid test or Huey Test is the most widely used method for determining the susceptibility of stainless steel to intergranular attack. In the earlier days of stainless steel usage in the Du Pont Company, it was widely used to screen stainless steel shipments for incorrect analysis, improper heat treatment and resistance to intergranular attack, regardless of the end use of the equipment. Its usage in recent years has been restricted primarily to evaluating stainless steels which will be used in nitric acid or in other services where intergranular attack can occur on sensitized or improperly heat treated grades. This test is described in A.S.T.M. A262.

##### b. Equipment

- (1) Flask Test. A one liter Erlenmeyer flask with either a 30 in. reflux condenser or a bulb-type condenser is used. Specimens are supported on glass hooks, stirrups, or cradles in the flask, fully immersed at all times during the test, and so designed that specimens tested in the same container do not come in contact with each other. Any method of heating that keeps the test solution boiling throughout the test period is satisfactory.
- (2) Multi-Sample Testing Apparatus. When a large number of specimens are to be tested, it is permissible to use a multi-sample testing apparatus especially

## 8.2.1.2

designed for the purpose and capable of accommodating as many as 40 specimens at one time. This equipment consists of a steam-jacketed silicon iron vessel with an integrally cast cup in the bottom and fitted with a stainless steel reflux condenser. Purified condensed acid drips from the reflux condenser into the cup and overflows from it into the main body of acid kept at a lower level in the kettle proper. With redistilled acid flowing through the cup at a rate of about four cup volumes per hour, the concentration of corrosion products in the acid will always be less than that encountered with conventional testing apparatus. Because of this lesser accumulation of corrosion products in the acid in contact with the test pieces, their rates of corrosion in the multi-sample apparatus are consistently lower than observed with single specimens in the flask test. See Par. 8.2.1.2 g and Fig. 1 for information on the effect of corrosion products on corrosion rate and Fig. 2 for comparison of rates in multi-sample and flask tests.

### c. Test Solution

The test solution is c.p.  $\text{HNO}_3$  and distilled water to provide a solution having a nitric acid concentration of  $65 \pm 0.2\%$  by weight as determined by analysis.

### d. Preparation of Specimens

- (1) The size and shape of the specimen must be considered with respect to available facilities for accurate weighing and the volume of the test solution to be used. Furthermore, in the case of bar, wire, and tubular products, the proportion of the total area represented by the cross-section exposed, may influence the results. When specimens of such products are being tested in research investigations, the ratio of the cross-sectional area exposed to the total area should be kept constant from test to test. For inspection tests, specimens cut from bars, wires, or tubes should be proportional so that the areas of the exposed cross-sections shall not exceed half the total exposed area of the specimen.
- (2) Special heat treatment of specimens prior to testing, or the use of specimens which contain a weld, may be specified.
- (3) When specimens are cut by shearing, the sheared edges should be refinished by machining or grinding prior to testing.

- (4) Specimens should be tested as received, except for cutting to size and surface finishing. Any scale on the specimens should be removed chemically prior to any further mechanical finishing treatment. Unless it is desired to test specimens having some particular surface finish, all surfaces of the specimen, including edges, should be finished using dry No. 120 grit abrasive paper.
- (4) The specimen should be measured and the total exposed area, including the inner surfaces of any holes, calculated.
- (5) The specimens are weighed to the nearest 0.001g.

#### e. Procedure

- (1) A sufficient quantity of the nitric acid test solution should be used to cover the specimen and to provide a volume of at least 125 ml. per sq. in. of specimen surface.
- (2) The best practice is to use a separate container for each material or treatment of material. However, it is acceptable to test as many as three specimens in the same container provided that they are all of the same grade and all show satisfactory resistance to corrosion. If more than one of the specimens tested in the same container fail to pass the test, it is necessary to retest all specimens in separate containers, since excessive corrosion of one specimen may result in accelerated corrosion of the other specimens tested with it.
- (3) The test ordinarily should consist of five boiling periods of 48 hours each, with a fresh test solution being used in each period. Instead of five 48 hour periods, a combination of one 48 hour period and two 96 hour periods (not necessarily in that order) may be acceptable.

#### f. Calculation and Report

The effect of the acid on the material shall be measured by determining the loss of weight of the specimen after each test period, and for the total of the test periods. Such weight loss determination shall be made with an analytical balance capable of weighing, to the nearest 0.001g., specimens having a total area of 50 sq. in. or less. The corrosion rates should be reported as inches penetration per month, calculated as follows:

$$R = \frac{K W}{AST}$$

## 8.2.1.2

where:

R = rate of corrosion in inches penetration per month,

K = 43.9 if A is in sq. in., or 283 if A is in sq. cm.,

W = wt. loss in grams,

A = total surface area in sq. in. or sq. cm.,

S = density of the sample in grams per cc,

T = duration of the test period in hours.

### g. Effect of Corrosion Products in the Nitric Acid

Information in this section was taken from "Testing Multiple Specimens of Stainless Steel in a Modified Boiling Nitric Acid Test Apparatus", by W.B. DeLong, American Society for Testing Materials, Special Technical Publication No. 93.

In the conventional technique for conducting boiling nitric acid tests, single specimens are exposed in 1000 ml. Erlenmeyer flasks on electrically heated hot plates. It has long been known that the inclusion of more than one specimen per test flask frequently leads to inaccurate results. Good practice has required that samples be exposed singly in the flasks and that an essentially constant ratio of sample surface to acid volume be maintained. These conditions indicated that it is the corrosion products of the solution of stainless steel in 65% nitric acid that causes the elevation of the corrosion rate of specimens known to have relatively low rates when exposed in the same flask with specimens of higher corrosion rates.

A brief investigation into the effects of the presence of the cations in solution that might accumulate by the corrosion of stainless steel indicated that chromium is the principal offender in causing high corrosion rates. These tests were conducted by adding iron, chromium, nickel and molybdenum salts in varying amounts to nitric acid and exposing samples of known corrosion rates in the solutions. Chromium was the only one of these elements that caused any appreciable effect on the corrosion rates of the standard specimens and it resulted in a marked increase in corrosion.

The relationship between chromium ion concentration in 65% HNO<sub>3</sub> and the corrosion of Types 304 and 316 stainless steel are shown in Fig. 1.

It will be noted that the boiling 65% nitric acid test does not in reality assess the corrosion resistance of a given stainless steel specimen to pure boiling nitric acid, but rather to the acid plus the products of corrosion of that particular sample. The standard test is, therefore, a self accelerating one and becomes more selective as the corrosion rate increases, in some respects a desirable characteristic.

#### h. Correlation Between Flask and Multiple Sample Methods

The multiple sample test generally gives a lower rate than the flask test for a given sample because of the lower chromium ion content. The correlation between the flask and multiple sample methods as determined on samples from 15 stainless steel types is shown in Fig. 2.

Par. 8.2.1 Fig. 1

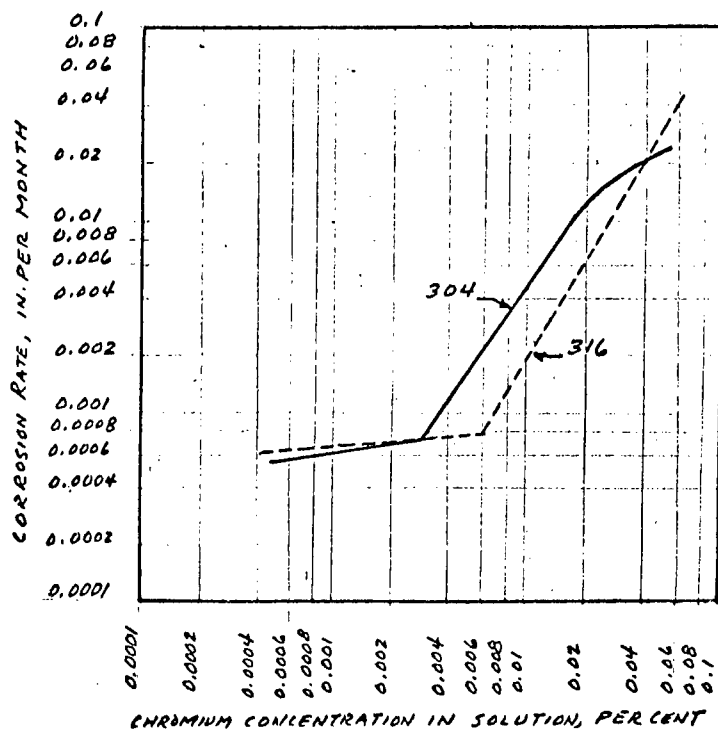

Fig. 1 Effect of Chromium Content in Boiling 65% Nitric Acid on the Corrosion of Stainless Steel

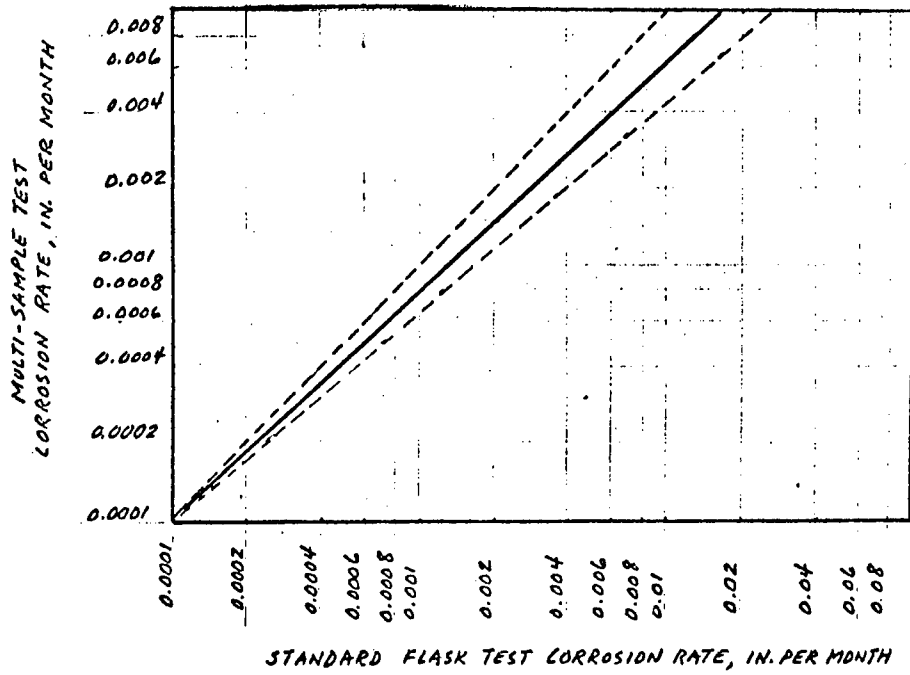

Fig. 2 Comparison of Multi-Sample and Standard Nitric Acid Test Corrosion Rates

### 8.2.1.3

#### 8.2.1.3 ELECTROLYTIC ETCHING METHOD FOR STAINLESS STEEL ACCEPTANCE TEST

##### a. General

The oxalic acid etch test as described in reference (1) at bottom of page is a method for determining the susceptibility of certain grades of stainless steel to intergranular corrosion. It is an acceptance test but not a rejection test. Materials passing the test need not be tested by the boiling 65% nitric acid test. Material failing the test shall be evaluated by the boiling 65% nitric acid test for acceptance or rejection. (The sulfuric acid-ferric sulfate test may be used in lieu of the boiling 65% nitric acid test.) The oxalic acid test is attractive in that a test can be carried out in less than one hour whereas the boiling nitric acid test requires at least 10 days, and the sulfuric acid-ferric sulfate test 5 days. Oxalic acid testing is applicable for acceptance testing only the following materials:

Wrought Types 304, 304L, and 316, cast Types CF-8(304), CF8M (316) and CN-7MCu (#20 alloy). The Type 304L is tested in the sensitized condition while all others are tested in the solution annealed condition.

##### b. Sample Preparation

Surface area to be prepared should be one square centimeter in area where possible. Specimens should be examined in cross section, if possible, to detect the occurrence of surface decarburization since such a condition may lead to erroneous conditions caused by the lower carbon content, particularly if samples are tested in the sensitized condition. Specimens to be etched are ground to 120 grit finish, then polished on successively finer emery papers, No. 1, 1/2, 1/0, and 3/0.

##### c. Etching Procedure

The specimen is made the anode of the etching cell by holding it in an electrical clamp which is connected to the positive terminal of a direct current source. The negative lead is connected to the cathode which may be a piece of stainless steel or the stainless steel beaker. An ammeter and a variable resistance are provided in the circuit.

Specimens are etched for 1.5 minutes at a current density of 1 ampere per square centimeter.

The electrolyte is a 10% by weight solution of oxalic acid in distilled water.

<sup>1</sup>"Screening Stainless Steels from the 240 Hr. Nitric Acid Test by Electrolytic Etching in Oxalic Acid", M. A. Streicher, ASTM Bulletin No. 188, February, 1953, p. 35.

#### d. Examination of Specimens

The specimens after etching are examined with a metallogical microscope at 200X to 500X. Stainless Types 304, 304L, CF8, and CN-7MCu which show a step structure or a dual structure after etching are considered acceptable. A step structure shows no intergranular ditches at grain boundaries. Since individual grains dissolve at different rates there is the appearance of a step at the grain boundaries. The dual structure is primarily a step structure, but with some intergranular ditches which do not completely surround grains. No individual grain is entirely encircled by ditches.

It has been found from comparative tests that those specimens exhibiting step or dual structure will always pass the boiling 65% nitric acid test. Those which exhibit ditch structure encircling one or more grains on oxalic acid test must be screened by boiling  $\text{HNO}_3$ , but many of these will be accepted.

For stainless Types 316 and CF8M (Type 316 castings) only those specimens showing the step structure are acceptable. Those showing the dual or ditch structure must be retested.

#### e. Selectivity of the Electrolytic Etching Method

Following the sensitizing time of one hour, which was formerly employed, the electrolytic etching method would accept only a small percentage of the samples that would be accepted by the boiling nitric acid test. This percentage would not exceed 25% and in many cases would be considerably less. The sensitizing time has now been reduced to the more realistic value of 20 min.<sup>2</sup> and as the result, the acceptance rate with the electrolytic etching method has improved somewhat.

The article "Screening Stainless Steels from the 240 hr. Nitric Acid Test by Electrolytic Etching in Oxalic Acid", by M. A. Streicher, A.S.T.M. Bulletin, No. 188, Feb. 1953, gives the following example of the selectivity of the test. Three lots of stainless steel designated as A, B, and C were evaluated by the oxalic acid test. Lots A and B were rejected because of a ditch structure around one or more of the grains after etching while lot C exhibited only the step structure. The attack on the sample representing lot A was more severe than that on lot B. The results of the tests for 240 hr. and 700 hr. in boiling nitric acid are listed below:

<sup>2</sup>"A Ferric Sulfate-Sulfuric Acid Test", M. A. Streicher, ASTM Bulletin No. 229, April, 1958.

## 8.2.1.3

---

Steel	Corrosion Rate In Inches Penetration Per Month	
	<u>240 hr.</u>	<u>700 hr.</u>
Lot A, (sensitized Type 304)	0.0035	0.0141
Lot B, (sensitized Type 304L)	0.0007	0.0012
Lot C, (annealed Type 304)	0.0007	0.0007

---

#### 8.2.1.4 Sulfuric Acid - Ferric Sulfate Test

##### a. General

Except for some specific cases, the sulfuric acid-ferric sulfate test\* has been adopted by Du Pont as the standard corrosion evaluation method for austenitic stainless steels which will be subjected to corrosive services capable of causing intergranular corrosion. This test largely supercedes the boiling nitric acid test. The electrolytic oxalic acid etch test is used as the initial acceptance test where it is applicable (See Par. 8.2.1.3), the rejected materials being rechecked by the sulfuric acid-ferric sulfate test or the boiling nitric acid test. In a series of comparative tests conducted on identical stainless steel materials by various industrial laboratories at the request of A.S.T.M. Committee A-10, Subcommittee IV, excellent agreement was realized on test results with the sulfuric acid-ferric sulfate test. This agreement was much better than with the boiling nitric acid test.

##### b. Testing Procedure

The test solution used is 50% sulfuric acid with ferric sulfate added as an inhibitor. The sulfuric acid is not consumed in the test, only the ferric salt. The amount of ferric sulfate consumed per gram of stainless steel dissolved is 10 grams. The specimens are tested for five days in a boiling solution. Residual oxide must be removed from the specimens prior to testing. The ferric sulfate acts as an inhibitor on clean stainless steel surfaces only and will not prevent galvanic attack in the presence of oxide. When conducting the test, use 600 ml. of 50%  $H_2SO_4$  in which 25 g. of ferric sulfate has been added. No change of acid is required during the test period. Specimens are measured and weighed prior to the test and weighed after the test as in the boiling nitric acid test, and corrosion rate calculations are made as specified for the nitric acid test. The maximum acceptable rate has been set at 0.0040 in./mo. A more realistic sensitizing time of 20 min. at 1250°F. instead of the former one hour at 1250°F. is employed.

##### c. Advantages

1. The test is shorter, easier, and less costly to perform. The test time is one-five day period instead of the minimum of 10 days with three periods required for the nitric acid test, and no changes of solution are required as compared with a minimum of two changes for the nitric acid test.

\*M. A. Streicher, ASTM Bulletin No. 229, p. 77, April, 1958, "A Ferric Sulfate-Sulfuric Acid Test".

#### 8.2.1.4

2. Use of the sulfuric acid-ferric sulfate test solution will not result in the formation of  $\text{Cr}^6$  in the corrosion product in the solution. The presence of corrosion product in the test solution, therefore, will not cause acceleration of the corrosion rate on the specimen, and will not cause end grain attack. The test actually evaluates the material for susceptibility to intergranular attack whereas the nitric acid test evaluates the stainless steel in nitric acid plus corrosion product which is not a true evaluation of the stainless steel.
3. The sulfuric acid-ferric test detects sensitized or carburized stainless steel as well as the nitric acid test does.
4. The test is suitable for use on Type 316L stainless steel since it will evaluate that stainless grade for sensitization by carbide precipitation only and not for presence of sigma phase. The nitric acid test detects sigma phase also in Type 316L and accordingly is not a good test when it is desired only to determine if carbide precipitation has occurred.

#### d. Disadvantages

1. Insufficient work has been performed on welds. There is an indication from test results performed to date that the method is not suitable for use on austenitic stainless steel welds. There have been several instances where weld samples, which passed the boiling nitric test with no difficulty, failed the sulfuric acid-ferric sulfate test.
2. The method is not suitable for evaluation of nitric acid resistance of Type 316L or other materials which contain sigma phase in the as welded or sensitized condition.

## 9. MILL PRODUCTS

9.1 Tubular Products9.1.1 General

This section will discuss both welded and seamless stainless steel pipe and welded and seamless heat exchanger tubing. Tubing is a tubular product that is specified dimensionally by O.D. and wall thickness. In the case of pipe, the dimensions are specified by nominal pipe size or i.p.s. (iron pipe size) for diameter and schedule number for wall thickness. Nominal pipe size and pipe O.D. are the same for pipe of 14 in. outside diameter and larger. (Table 1 gives dimensions and weights for pipe sizes 1/8 in. through 10 in.)

9.1.2 Production of Tubing and Pipe9.1.2.1 Seamless Products<sup>1</sup>a. Production by Direct-rolled Hot Finishing

Seamless stainless steel tubes and pipe are made from solid bars or "tube rounds". Stainless tubular products are now finished by cold drawing only to permit better surface finish, closer tolerances, and closer control of grain size in final heat treating operations. Intermediate operations may or may not be performed hot depending on type of stainless steel and final size.

Stated briefly, the seamless process consists of heating the "tube round", piercing a hole through it longitudinally, and in the same operation rolling the tube to a desired diameter and wall thickness. Auxiliary finishing operations include reeling, sizing, or sinking of the hot tube, followed thereafter by cold drawing or "tube reducing" to final size. (Hot extrusion may be substituted for piercing and in some cases all subsequent operations are performed cold.)

When stainless steel tubes are produced by rotary piercing, the following operation is followed:

- (1) Centering and heating - A machine turned round is sent to a centering machine where a shallow hole is drilled in the center of one end. The center

### 9.1.2.1

hole provides clearance for the nose of the point at the start of the piercing operation. In the case of certain of the highly alloyed stainless grades, a small diameter hole may be drilled throughout the entire length of the billet to ease the load in the mill and to assist in preserving the piercer point until the pierce is completed. After the drilling operation, the round is heated to the proper temperature for piercing.

- (2) Piercing and hot extrusion operations - As shown in Figure 1, the rolls grip the round between their faces, rotate it rapidly, force and expand it over a conical tool known as the "piercing point". As the round advances over the point and bar, it takes a tubular form, the wall thickness being regulated by the space between the shoulder of the piercing point and the rolls. (Certain sizes and types of tubes, usually in the more "refractory" alloys which do not lend themselves to rotary piercing, are being produced by hot extrusion (Figure 2). See Par. 9.1.2.1b for details of the hot extrusion operation.)
- (3) Rolling - After rotary piercing or hot extrusion, the tube hollow is sent to a rolling mill to lengthen the tube and reduce the wall thickness to the approximate dimensions required. As shown in Figure 3, the rolling mill consists of two grooved rolls, similar to the rolls in a bar mill, but with the addition of a plug, which lies within the grooves of the rolls, and is the approximate size of the internal diameter of the tube. The rough-pierced tube is reheated to the proper temperature, delivered to the rolling mill and pushed by a powerful ram into the grooves of the rolls. The rotation of the rolls carries it forward over the plug and bar, working the metal between the roll groove surfaces and the plug. By means of a set of stripper rolls, the tube is removed from the bar and returned to the inlet side of the mill. Five or six or even more passes with change of plugs may be required in rolling stainless steel tubes. In order to make the wall of the tube uniform and to avoid ribs or overfills, the tube is turned ninety degrees between each pass through the rolling mill.
- (4) Reeling and sizing - After piercing and rolling, the tube is in a semi-finished condition, i.e., it is of the required wall thickness and approximate

diameter, but the surface is somewhat rough. Directly after rolling, and while the tube is still hot, it is conveyed to what is known as a reeling machine. The reeling machine, shown diagrammatically in Figure 4, consists of two rolls having rather long parallel surfaces. These rolls operate by cross rolling similarly to the piercing mill. The reeling rolls both rotate in the same direction and their axes are inclined slightly so as to engage the tube on its two sides and force it spirally over a smooth mandrel or "reeler plug", which is supported on a thrust bar on the outlet side of the mill. Rolling the tube over the plug removes light overfills and scratches from the previous rolling operation and generally smooths and burnishes the surface. The tube is also rounded and expanded somewhat in diameter, but remains somewhat constant in wall thickness or is reduced slightly depending on the pressure applied.

When the tube has passed through the reeler, the thrust bar is withdrawn and the tube proceeds to a sizing mill. The sizing mill consists of several sets of roll stands having single-grooved rolls set in tandem whose function it is to hot size the tube to its proper diameter.

The foregoing describes the essential operations in the production of direct-rolled hot finished tubing or pipe. Since almost all the hot-working operations described are performed by mandrels or plugs supported in compression, tubes cannot be commercially made and finished by this process below about 2 in. outside diameter except in very short lengths.

Stainless steel tubes are finished by suitable cold operations which will be described in Par. 9.1.2.1c.

#### b. Hot Extrusion

With the advent of hot extrusion, it became possible to produce tubular products from alloys which could not be handled by the rotary piercing method. Some of the alloys which now can be made into tubing by hot extrusion include 19-9DL, 440C, A286, and 17-4PH. Figure 2 shows important details of the hot extrusion process. The hot billet is placed in a container and a hole is pierced through the center with a piercing mandrel. In some cases the center hole is drilled. The pierced billet is reheated to the hot

#### 9.1.2.1

extrusion temperature, rolled in powdered glass which melts to coat the surface with molten glass, and then placed in a container between a die and a ram. The ram advances and pushes the metal through the die, and the emerging metal takes the form of the opening in the die. Lubrication from the molten glass is required on each surface where the hot metal slides over the tools of the extrusion press. The Ugine-Sejournet hot-extrusion process described above differs from conventional hot extrusion in that the molten glass lubricant is used.

The tube hollows produced by hot extrusion may be reduced hot or cold to the final size, depending on the alloy and the intended use of the finished product. The sequence of operation in manufacturing 0.750 in. O.D. x 0.109 in. wall Type 309SCb tubing by hot extrusion followed by cold reducing is given in Par. 9.1.4.1.

#### c. Cold Drawing

Seamless tubing to be cold drawn is given the same rotary piercing (or hot extrusion), rolling, reeling, and sizing or reducing operations as tubing that is to be hot-finished. Prior to cold drawing the tube is inspected and all surface defects are removed by filing, grinding, turning, or boring. In addition there may be pickling to remove scale and annealing to have the material in the proper condition for exposure to pickling acids. (Seamless tube hollows are supplied to redraw mills throughout the country where they are cold drawn to smaller diameter seamless products.) Tubes are then hot pointed in swaging dies or under a power hammer so as to provide a "tang" for the grips of the draw bench carriage, and to permit entry into the die through which they are to be drawn. After pointing, tubes of some compositions are annealed, then pickled or cleaned to remove all traces of scale or oxides, after which a suitable lubricant or drawing compound is applied.

The apparatus used for cold drawing consists of a heavily constructed draw bench in the center of which is positioned a die through which the tube is drawn. A heavy, square-linked endless chain travels along the top of the bench and is geared to a suitable source of power. Figure 5 shows the general arrangement of a cold-draw bench and an enlarged section of the tube die and mandrel. (The tube shown in Figure 5 is being "plug" drawn.)

The prepared and annealed tube, now cold, and with lubricant applied is partially inserted in the die with its pointed end projecting through. A mandrel attached to a bar is placed in the tube from the opposite end and the pointed end of the tube is grasped by the grips of the carriage. The hook is then engaged in the traveling chain and the tube is thus drawn, being literally squeezed through the die or between the die and the mandrel previously inserted. The mandrel is kept in position by the bar attached to the back end of the draw-bench frame. The bar goes inside the tube to hold the mandrel in proper alignment with the die while the tube is being drawn.

(The operation previously described is often called "plug" drawing. Another type of drawing operation involves threading the tube over a bar of the desired size, grasping both the tube and bar in the grips of the carriage and pulling both tube and bar through the die. This method produces a more accurate tube with regard to concentricity of O.D. with I.D. A reeling operation is required after "bar drawing" to release the tube from the bar. The slight surface indentations produced by the rolls in the reeling operation can give difficulties in eddy current testing. Par. 9.1.4.2 gives a sequence of operations for producing welded tubing where the first draw was a "bar draw" and the second a "plug draw" to give a better surface for eddy current testing.)

Following drawing, the tube is annealed, repickled, and relubricated, and the cycle of operations repeated until the desired size is obtained. The drawing operation reduces both diameter and wall thickness, the amount of reduction per pass being governed by the physical characteristics of the metal and the physical dimensions of the tube. (In many cases the final draw-bench operation is a "sink" pass. In this case no bar or mandrel is inserted in the tube when it is drawn through the die and accordingly the tube is reduced in diameter and lengthened with no significant change in wall thickness.) Final operations, after cold drawing, consist of applying an appropriate heat treatment, descaling, straightening, cutting to length and inspecting.

#### d. Tube-Reducing<sup>2</sup>

In some cases a cold-reducing operation known as "tube-reducing" or "rocking" is used in lieu of

### 9.1.2.1 - 9.1.2.2

draw-bench operations. In the tube reducing operation illustrated in Figure 6, the tube is reduced in diameter by compression over a tapered mandrel. The rocking-cam dies are semi-circular in shape. Each has a tapered groove which straddles the tube round. The dies rock back and forth as the tube round simultaneously rotates. In time, they could reduce the original diameter of the tube round some 25%, and the original wall thickness about 50%. (These amounts can be varied.) As the tube round passes through the rocking dies, it approximately doubles its original length. The polished, tapered mandrel controls the inside diameter; the cam dies control the outer diameter.

#### e. Forging and Boring

Heavy wall, large O.D. pipe is, on occasions, produced by forging a tube hollow and then boring the I.D. and machining the O.D. to the desired dimensions. With the advent of larger size hot extrusion presses, there is less demand for forged and bored pipe.

#### f. Centrifugal Casting Plus Cold Expansion

A recently developed method for the production of large diameter seamless pipe involves centrifugal casting to a desired size and then hydraulically expanding the cast pipe in a retaining cylinder to cold work the cast structure. On subsequent annealing, the structure becomes similar to that of a wrought material.

### 9.1.2.2 Welded Products

#### a. Heat Exchanger Tubing

Welded heat exchanger tubing is normally supplied in the full finished condition, which means for most sizes that it has been drawn and reannealed after welding. In some sizes where the diameter is rather large, the mill, if not instructed otherwise, may choose to swage and anneal rather than to draw and anneal to produce the final size. Comments on this manufacturing method are found later in this section.

In welded tube mills, stainless steel strip from rolls is continuously formed into tubing. The edges of the formed strip are joined by the inert gas shielded tungsten arc method without addition of filler metal. The underside of the weld is protected

from oxidation by an auxiliary flow of inert gas. Most mills roll the strip into tubing so that the seam is on the top and deposit the weld from the O.D. of the tube on the top. One mill rolls the strip into tubing so that the seam is on the bottom and deposits the weld from the outside of the tubing in the overhead position on the underside. They have found that welds deposited in this position have a slightly concave contour at the root. This contour is more desirable than a convex weld in subsequent drawing operations.

After welding, the projecting portion of the face of the weld on the tube O.D. is removed by belt grinding or flattened by swaging. In a swaging machine, there is a rapid hammering action which removes any projections by flattening them and also removes out of roundness from the tubing. There is little wall thickness reduction.

Some mills anneal and pickle prior to the first drawing operations while others do not. Drawing is performed by the methods described in Par. 9.1.2.1c in the section on seamless products. After each drawing operation, the drawing lubricant is removed by a degreasing operation, usually vapor degreasing. In some mills, the tubes are degreased and pickled. They are then annealed, most generally in a furnace with an oxidizing atmosphere, but sometimes in a bright annealing furnace. In emerging from the continuous furnace the tubes are water quenched or air cooled. If the tubes were annealed in an oxidizing atmosphere, they are pickled prior to the next cold reducing operation. The final cold drawing operation is usually a sinking pass where the O.D. is reduced to an accurate final dimension with little reduction in wall thickness.

Most purchasers of welded tubing do not specify any definite amount of cold reduction since in most services there is little difference in performance for varying degrees of cold reduction of the tubing. For tubing to be used in some severely corrosive services sufficient cold reduction is required that after annealing, the dendritic cast structure of the weld is recrystallized and assumes the appearance of wrought material. Approximately 15% wall thickness reduction is required before complete recrystallization of the weld will occur. Swaging does not cold reduce the weld sufficiently that it will be recrystallized when subsequently annealed.

## 9.1.2.2 - 9.1.3.1

### b. Welded Pipe

Many welded tube mills produce pipe up to 2 in. Schedule 40 and 4 in. Schedule 10 on the same type of equipment that is used to produce welded heat exchanger tubing. No filler metal is added during the welding process. The welded pipe is sold in the "as welded" condition, in which case it is merely straightened after welding, or is solution annealed, pickled, and straightened after welding.

For pipe sizes larger than listed above, the plate is usually formed into pipe on a press brake and the weld is made usually by an automatic process that involves the deposition of filler metal. Such pipe is normally heat treated after welding.

One manufacturer of welded pipe offers a product which is tube reduced or "rocked" after welding to convert the cast structure of the weld to a wrought structure.

### 9.1.3 Specifications

#### 9.1.3.1 A.S.T.M. Specifications

A.S.T.M. specifications which cover tubular products are listed below: (Par. 2.3 lists the A.S.T.M. Specifications available for each stainless steel type).

A312-61T - Seamless and Welded Austenitic Stainless Steel Pipe - Under this specification, the pipe shall be made by the seamless or an automatic welding process with no addition of filler metal in the welding operation. At the manufacturer's option, pipe may be furnished either hot finished or cold finished. The pipe shall be pickled free from scale. When bright annealing is used, pickling is not necessary. All pipe to this specification is furnished in the solution annealed condition. (In general, welded pipe to this specification is limited to the following maximum sizes: 2 in. Schedule 40, 4 in. Schedule 10, and 4 in. Schedule 5. There are no limitations on the size of seamless pipe other than those imposed by manufacturing facilities.)

A358-60T - Electric-Fusion-Welded Austenitic Chromium - Nickel Alloy Steel Pipe for High-Temperature Service - Although no restrictions are placed on the sizes of pipe which may be furnished under these specifications, commercial practice is commonly limited to sizes not less than 8 in. nominal diameter.

The joints shall be double-welded, full-penetration welds made in accordance with procedures and by operators qualified in accordance with the A.S.M.E. Boiler and Pressure Vessel Code, Section IX. The welds shall be made either manually or automatically by an electric process involving the deposition of filler metal. Stainless steel plate material used for the pipe shall conform to A.S.T.M. A240. All finished pipe shall be furnished in solution annealed condition.

A376-61T - Seamless Austenitic Steel Pipe for High-Temperature Central-Station Service - At the manufacturer's option, pipe may be furnished either hot-finished or cold-finished with, where necessary, a suitable finishing treatment. All pipe to this specification is furnished in the solution annealed condition.

A409-60T - Welded Large Outside Diameter Light-Wall Austenitic Chromium - Nickel Alloy Steel Pipe for Corrosive or High-Temperature Service - The sizes covered by this specification are 14 to 30 in. inclusive in Schedules 5 and 10. The welds shall be made by the manual or automatic electric welding process. For manual welding the operator and procedure shall be qualified in accordance with the A.S.M.E Boiler and Pressure Vessel Code, Section IX. Pipe to this specification is not heat treated unless specified by the purchaser.

A430-61T - Austenitic Steel Forged and Bored Pipe for High-Temperature Service - The material shall be forged by hammering, pressing, rolling, or extruding, and shall be brought as nearly as practicable to the finished shape and size by hot working. The material shall be adequately worked under a tool of sufficient capacity to refine the structure in the wall of the finished pipe. All forgings shall have both the inner and outer surfaces machined. The pipe shall be machined to a finish not coarser than 250 rms after heat treatment, unless otherwise specified. Pipe furnished to this specification shall be solution annealed.

A213-61T - Seamless Ferritic and Austenitic Alloy - Steel Boiler Superheater and Heat-Exchanger Tubes - This specification covers tubes 1/2 to 5 in. inclusive, in outside diameter and 0.035 to 0.500 in., inclusive in minimum wall thickness. All austenitic stainless steel tubes to this specification shall be furnished in the solution annealed condition.

### 9.1.3.1 - 9.1.3.2

A249-61T - Welded Austenitic Steel Boiler, Superheater, Heat-Exchanger, and Condenser Tubes - This specification covers tubes 1/2 to 5 in. inclusive, in outside diameter and 0.035 to .320 in., inclusive in minimum wall thickness. The tubes shall be made from flat rolled steel by an automatic welding process with no addition of filler metal. Subsequent to welding and prior to final heat treatment, the tubes shall be cold worked to assure that optimum corrosion resistance in the weld area and base metal will be developed during heat treatment. All tubes shall be furnished in the solution annealed condition.

A268-61 - Seamless and Welded Ferritic Stainless Steel Tubing for General Service - Tubing to this specification is furnished to average wall thickness. Tubes shall be made by the seamless or welded process. All material shall be furnished in the heat-treated condition unless otherwise agreed between the manufacturer and the purchaser and so specified in the order. The heat treatment shall be performed by a method and at a temperature selected by the manufacturer.

A269-61 - Seamless and Welded Austenitic Stainless Steel Tubing for General Service - Tubing to this specification is furnished to average wall thickness. The tubes shall be made by the seamless or welded process. At the manufacturer's option, tubing may be furnished either hot finished or cold finished. The tubes shall be pickled free from scale. When bright annealing is used, pickling is not necessary. All material shall be furnished in the solution annealed condition.

#### 9.1.3.2 Military Specifications

Tubing to Military Specification MLL-T-18063A (Ships) "Tube and Pipe, Corrosion-Resisting Steel, Seamless and Welded, Radioactive System Service", has been used by Du Pont for power reactor service. This specification covers Types 304, 304L, 347, and 348 in seamless pipe and tube, and electric welded pipe and tube with or without filler rod. This specification calls for corrosion evaluation tests, ultrasonic test, liquid penetrant examination and, in the case of welded products, radiographic examination. (One mill applies an extra of 35% to base price when furnishing seamless tubing to this specification.)

9.1.4 Examples of Tubing Manufacturing Procedures

This section will describe the manufacturing processes used in the production of three sizes of stainless steel tubing for Savannah River Plant. These include (1) 3/4 in. O.D. x 0.109 in. wall Type 309 SCb seamless tubing for severely corrosive services, (2) 1 in. O.D. x 0.134 in. wall welded tubing for severely corrosive services, and (3) 1/2 in. O.D. x 0.049 in. wall welded tubing for a critical water service.

9.1.4.1 3/4 in. O.D. x 0.109 in. Wall Type 309 SCb Seamless Tubing

This tubing was produced by hot extruding followed by cold reducing by the tube reducing method and draw-bench operations. The sequence of operations is listed below:

- (1) Pour into 14 in. x 14 in. ingots.
- (2) Breakdown cast structure of ingot by hot rolling into bar stock.
- (3) Machine bars into billets 6.850 in. dia. x 14 1/2 in. long.
- (4) Spray billets with porcelain enamel.
- (5) Heat to 2180°F. for piercing (enamel prevents oxidation).
- (6) Pierce 2.6 in. dia. hole longitudinally through billet.
- (7) Induction heat to bring pierced billet to 2180°F.
- (8) Roll billet in powdered glass.
- (9) Extrude to 3.50 in. O.D. x 0.450 in. wall x 9 ft. 4 in. long.
- (10) Remove glass by immersion in hot caustic solution.
- (11) "Salt pickle" to remove scale ( $H_2SO_4+NaCl$ ).
- (12) Straighten.
- (13) Trim to length.
- (14) Classify and condition (trim to remove defective areas).
- (15) Taper end for tube reducing.
- (16) Tube reduce to 2.375 in. O.D. x .275 in. wall x 18 ft. 6 in. long.
- (17) Cut in half (9 ft. 3 in.).
- (18) Degrease with alkaline compound.
- (19) Anneal at 2000°F., water quench.
- (20) Salt pickle (see No. 11 above).
- (21) Rough Straighten.

9.1.4.1 - 9.1.4.2

- (22) Classify for defects.
- (23) Tube reduce to 1.500 in. O.D. x 0.175 in. wall x 23 ft. - 0 in. long.
- (24) Cut in half (11 ft. 6 in.).
- (25) Degrease (see No. 18 above).
- (26) Anneal at 2000°F., water quench.
- (27) Salt pickle (see No. 11 above).
- (28) Rough straighten.
- (29) Classify for defects.
- (30) Tube reduce to 0.840 in. O.D. x 0.109 in. wall x 33 ft. 5 in.
- (31) Degrease (see No. 18 above).
- (32) Anneal at 2000°F., water quench.
- (33) Salt pickle (see No. 11 above).
- (34) Rough straighten.
- (35) Induction heat 8 in. length on one end.
- (36) Form point on end for grip during drawing.
- (37) Pickle to remove scale from pointed end.
- (38) Sink pass on draw-bench to 0.750 in. O.D. x .109 in. wall x 35 ft. long.
- (39) Cut points off.
- (40) Degrease (see No. 18 above).
- (41) Finish anneal at 2150°F. for 1/2 hr., water quench, + 1550°F. for 4 hr., air cool.
- (42) Salt pickle (see No. 11 above).
- (43) Rough straighten.
- (44) Rotary straighten.
- (45) Cut corrosion test coupons..
- (46) Hydrostatic test.
- (47) Acid pickle (HNO<sub>3</sub>-HF).
- (48) Final pickle.

Tubing made in this manner would not pass corrosion evaluation tests because of I.D. carburization resulting from retained organic material on the surface (drawing lubricant) during the annealing steps. More careful cleaning following tube reducing or sinking and prior to annealing might have remedied this situation. This tubing was difficult to clean because of long lengths involved.

9.1.4.2 1 in. O.D. x 0.134 in. Wall Type 304L Welded Tubing

This tubing size is not normally produced as full finished welded tubing. In this case, a minimum tube hollow size prior to drawing was specified and a maximum carbon content was specified for outer 0.005 in. on I.D. of tubing.

The sequence of operations is listed below:

- (1) Form and weld to 1 1/2 in. O.D. x 0.154 in. wall.
- (2) Swage.
- (3) Point.
- (4) Pickle (HNO<sub>3</sub>-HF).
- (5) Bar-draw to 1.315 in. O.D. x 0.147 in. wall.
- (6) Vapor degrease and pickle (HNO<sub>3</sub>-HF) to clean.
- (7) Oxide anneal (approximately 2000°F.) water quench.
- (8) Machine straighten.
- (9) Abrasive cut 1/2 of point and back end.
- (10) Re-point.
- (11) Pickle (HNO<sub>3</sub>-HF).
- (12) Dope and dry.
- (13) Plug-draw to 1.000 in. O.D. x 0.139 in. wall x 22 ft. 4 in. (with point).
- (14) Vapor degrease and pickle (HNO<sub>3</sub>-HF) to clean.
- (15) Oxide anneal (approximately 2000°F.) water quench.
- (16) Machine straighten.
- (17) Abrasive cut all of point and back end (cut to approximately 22 ft.).
- (18) Hydrostatic test.
- (19) Pickle (HNO<sub>3</sub>-HF).
- (20) Pre-inspect before x-ray.
- (21) X-ray 100%.
- (22) Eddy current test 100%.
- (23) Abrasive cut 7 ft. 0 in. + 1/8 in. -.000 in.
- (24) Passivate in HNO<sub>3</sub> to remove abrasive grit and handling marks.
- (25) Final inspection (visual).

This material passed the corrosion evaluation test without difficulty. There was no evidence of I.D. carburization. The cleaning procedure which consisted of vapor degreasing plus pickling after each cold forming operation was successful in removing drawing lubricant prior to the annealing operation.

9.1.4.3

9.1.4.3 1/2 in. O.D. x 0.049 in. Wall Type 304L Welded Tubing

This tubing was produced by welding and drawing, followed by eddy current testing as the final inspection. The following manufacturing procedure was followed:

- (1) Form 0.120 in. thick strip to form 1 1/4 in. O.D. tubing and weld.
- (2) Belt sand weld O.D. to remove weld reinforcement.
- (3) Vapor degrease.
- (4) Bright anneal at 2000°F., rapid air cool.
- (5) Form point on end for drawing.
- (6) Bar draw.
- (7) Cut to length.
- (8) Vapor degrease.
- (9) Anneal (see Item 4)
- (10) Form point on end for drawing.
- (11) Bar draw to final wall thickness (O.D. will be greater than finished size).
- (12) Cut to length.
- (13) Sink to final O.D. (wall thickness remains the same).
- (14) Vapor degrease.
- (15) Bright anneal at 2000°F., rapid air cool.
- (16) Straighten.
- (17) Polish O.D. (180 grit).
- (18) Cut to final length (30 ft.).
- (19) Grit blast I.D. (220 alundum grit).
- (20) Visual inspection.
- (21) Hydrostatic test.
- (22) Eddy current test.
- (23) Passivate in 20% HNO<sub>3</sub>.
- (24) Water rinse and dry.

Tubing made in the above manner was entirely satisfactory for the intended application. This process is of interest because no acid pickling was employed. The grit blasting step was required only because air was not completely excluded from the I.D. of the tubing during the bright annealing operation, resulting in a very thin straw colored oxide film.

SOURCES OF INFORMATION

1. Technical Bulletin 6H, "Seamless Steel Tubing", Babcock & Wilcox Company, Tubular Products Division, 1959.
2. Seme, J. A., "Rock-Forging 'Irons' Welds to Give Quality Tubing", Reprint from Iron Age, Swepeco Tube Corporation.

Par. 9.1 Figs. 1 and 2

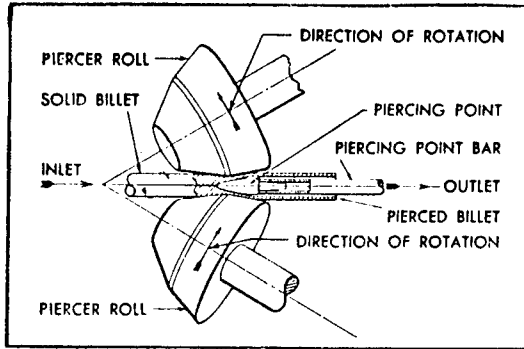

Fig. 1 Rotary Piercing Operation

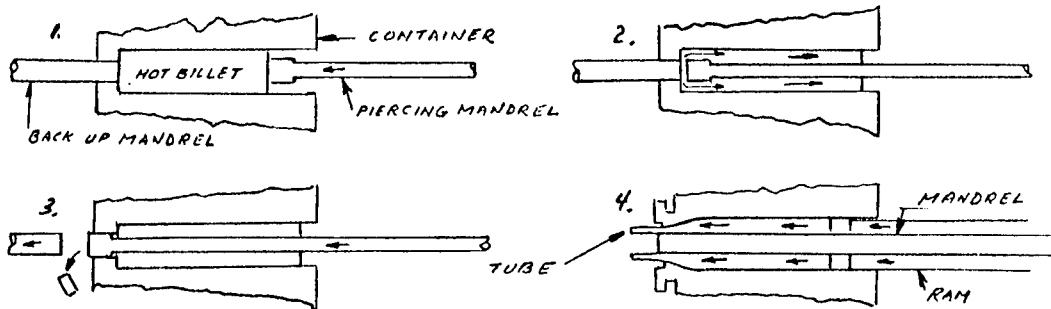

Fig. 2 Hot Extrusion Process

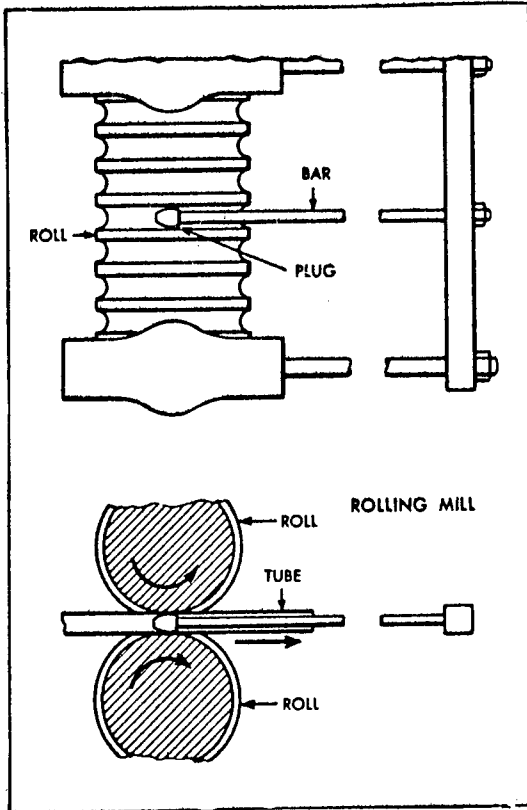

Fig. 3

Rolling Operation

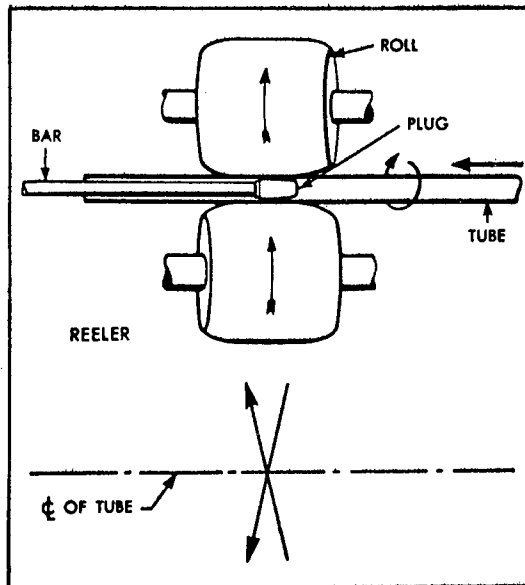

Fig. 4

Reeling Operation

Par. 9.1 Figs. 5 and 6

Fig. 5  
Cold Drawing Operation

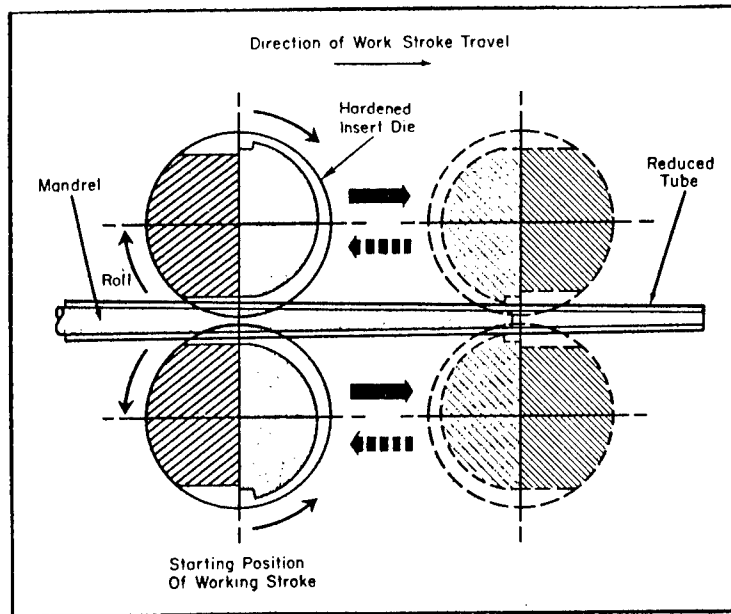
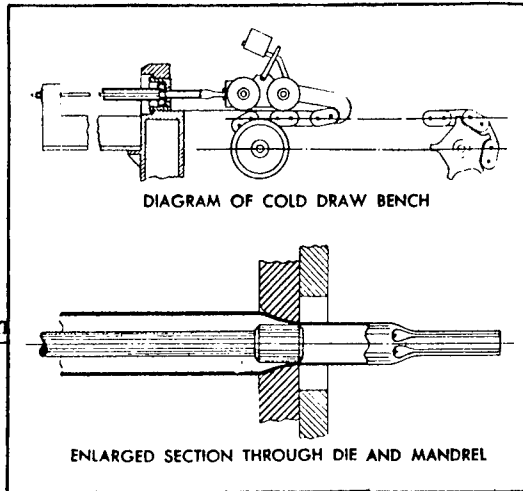

Fig. 6 Tube Reducing or "Rocking" Operation

**Table 1 DIMENSIONS AND WEIGHTS OF PIPE SIZES**

NOMINAL PIPE SIZE Inches	OUTSIDE DIAMETER Inches	I.P.S. SCHEDULE	WALL Inches	INSIDE DIAMETER Inches	WT/FT Pounds	NOMINAL PIPE SIZE Inches	OUTSIDE DIAMETER Inches	I.P.S. SCHEDULE	WALL Inches	INSIDE DIAMETER Inches	WT/FT Pounds
1/4	.405	10S	.049	.307	.1863	3	3.500	5S	.083	3.334	3.029
		40 40S Std.	.068	.269	.2447			10S	.120	3.260	4.332
		80 80S Ex. Hvy.	.095	.215	.3145			40 40S Std.	.216	3.068	7.576
1/4	.540	10S	.065	.410	.3297	3 1/2	4.000	5	.083	3.834	3.472
		40 40S Std.	.088	.364	.4248			10 10S	.120	3.760	4.973
		80 80S Ex. Hvy.	.119	.302	.5351			40 40S Std.	.226	3.548	9.109
3/8	.675	10S	.065	.545	.4235	4	4.500	5S	.083	4.334	3.915
		40 40S Std.	.091	.493	.5676			10S	.120	4.260	5.613
		80 80S Ex. Hvy.	.126	.423	.7388			40 40S Std.	.237	4.026	10.79
1/2	.840	5S	.065	.710	.5383	5	5.563	5S	.109	5.345	6.349
		10S	.083	.674	.6710			10S	.134	5.295	7.770
		40 40S Std.	.109	.622	.8510			40 40S Std.	.258	5.047	14.62
3/4	1.050	80 80S Ex. Hvy.	.147	.546	1.088	6	6.625	80 80S Ex. Hvy.	.337	3.826	14.98
		160 XX Hvy.	.187	.466	1.304			120	.438	3.624	19.00
			.294	.252	1.714			160	.531	3.438	22.51
1	1.315	5S	.065	.920	.6838	8	8.625	5S	.109	8.407	9.914
		10S	.083	.884	.8572			10S	.148	8.329	13.40
		40 40S Std.	.113	.824	1.131			20	.250	8.125	22.36
1 1/4	1.660	80 80S Ex. Hvy.	.154	.742	1.474	10	10.750	30	.307	10.136	34.24
		160 XX Hvy.	.218	.614	1.937			40 40S Std.	.365	10.020	40.48
			.308	.434	2.441			60 80S Ex. Hvy.	.500	9.750	54.74
1 1/2	1.900	5S	.065	1.185	.8678	10	10.750	80	.593	9.564	64.33
		10S	.109	1.097	1.404			100	.718	9.224	76.93
		40 40S Std.	.133	1.049	1.797			120	.812	9.064	89.20
2	2.375	80 80S Ex. Hvy.	.179	.957	2.172	10	10.750	140	.875	8.875	72.42
		160 XX Hvy.	.250	.815	2.844			160	.906	8.813	74.69
			.358	.599	3.659						
2 1/4	2.875	5S	.065	1.530	1.107	10	10.750	20	.250	10.250	28.04
		10S	.109	1.442	1.806			30	.307	10.136	34.24
		40 40S Std.	.140	1.380	2.273			40 40S Std.	.365	10.020	40.48
2 1/2	2.875	80 80S Ex. Hvy.	.191	1.278	2.997	10	10.750	60 80S Ex. Hvy.	.500	9.750	54.74
		160 XX Hvy.	.250	1.160	3.765			80	.593	9.564	64.33
			.382	.896	5.214			100	.718	9.224	76.93
3	3.500	5S	.065	1.770	1.274	10	10.750	120	.812	9.064	89.20
		10S	.109	1.682	2.085			140	.875	8.875	72.42
		40 40S Std.	.145	1.610	2.718			160	.906	8.813	74.69
3 1/2	4.000	80 80S Ex. Hvy.	.200	1.500	3.631	10	10.750	180	1.000	8.750	104.1
		160 XX Hvy.	.281	1.338	4.859			200	1.125	8.500	115.7
			.400	1.100	6.408						

From: Babcock & Wilcox Company Technical Bulletin 15-C

**NOTE:**

Weights shown are in pounds per foot, based on the average wall of the pipe. The following formula was used in calculating the weight per foot.

W = 10.68 (D - t)  
 W = Weight in pounds per foot (to 4 digits)  
 D = Outside Diameter in inches (to 3 decimal places)  
 t = Wall thickness in decimals (to 3 decimal places)

All weights are carried to four digits only, the fifth digit being carried forward if five or over, or dropped if under five.

## 9.2 - 9.2.4

### 9.2 Plate

#### 9.2.1 Definitions

The terms plate, sheet, and strip are described as follows:

Plate - Material 3/16 in. and over in thickness and over 10 in. in width.

Sheet - Material under 3/16 in. in thickness and 24 in. and over in width.

Strip - Material under 3/16 in. in thickness and under 24 in. in width.

#### 9.2.2 Specifications

A.S.T.M. specifications for stainless steel plate, sheet and strip are listed below:

A.S.T.M. A167-61T - Corrosion-Resisting Chromium-Nickel Steel Plate, Sheet, and Strip

A.S.T.M. A176-61T - Corrosion-Resisting Chromium Steel Plate, Sheet, and Strip

A.S.T.M. A240-61T - Corrosion-Resisting Chromium and Chromium-Nickel Steel Plate, Sheet, and Strip for Fusion-Welded Unfired Pressure Vessels

The primary difference between A.S.T.M. A240 and A167, in the case of the austenitic or 300 series stainless steels, is that A240 requires that they be heat treated for best resistance to intergranular corrosion. When purchasing stainless steel plate to A.S.T.M. A240 requirements, the purchaser can specify that the steels be corrosion evaluated by the supplier.

The A.S.M.E. Unfired Pressure Vessel Code permits the use in pressure vessels of austenitic stainless steel plate to A.S.T.M. A240 requirements. For the 400 series stainless steels, the A.S.M.E.-U.P.V. Code permits the use of plate to A.S.T.M. A240 requirements. A.S.M.E. Code allowable stress values for the various grades of stainless steel plate are shown in Par. 6.6, Tables 1 and 2.

#### 9.2.3 Compositions

The chemical compositions of the grades of stainless steel plate covered by A.S.T.M. Specifications A167, A176, and A240 are shown in Tables 1 and 2.

#### 9.2.4 Types of Finish

The applicable A.S.T.M. specifications for stainless steel plate list the following types of finish as procurable on plates:

Hot-Rolled, Annealed or Heat Treated - Scale not removed. Use of plates in this condition is generally confined to heat-resisting applications. Scale impairs corrosion resistance.

Hot-Rolled, Annealed or Heat Treated, Blast Cleaned or Pickled - Condition and finish commonly preferred for corrosion-resisting and most heat-resisting applications.

Hot-Rolled, Annealed or Heat Treated, Surface Cleaned and Polished - Polish finish is generally No. 4 finish.

#### 9.2.5 Tolerances, Allowances, Limits, Weights

Thickness tolerances	- Table 6*
Width and length tolerances	- Table 7*
Diameter tolerance, circular plates	- Table 7*
Annealed plates, flatness	- Table 7*
Sheared or universal mill plates - camber	- Table 7*
Allowances for surface machining	- Table 8*
Recommended flame cutting allowances for edge clean-up	- Table 5*
Circle shearing limits	- Table 7*
Mill size limitations (maximum lengths for widths and thicknesses listed) vs. stainless steel types	- Tables 9* and 10*
Plate billing weights	- Table 8*

#### 9.2.6 Testing and Inspection

All A.S.T.M. specifications covering stainless steel plate require that the chemical composition (ladle analysis) be determined, and also the tensile strength, yield strength, per cent elongation, hardness, and bending properties (in the case of the 400 series stainless steels). In addition, the suppliers will, when specified, conduct a boiling nitric acid (Huey) test or acidified copper sulfate (Strauss) test.

As indicated in Table 4\*, the tests required by the applicable A.S.T.M. specifications are conducted free of charge.

Other tests which may be specified, but for which there is a charge, are listed below:

- Check analysis
- Tensile test at low temperature
- Impact tests
- Ultrasonic inspection
- Liquid penetrant inspection

#### 9.2.7 Cost Information

Base price information is shown in Table 3. The costs of various extras, including those for the special tests listed above, are shown in Tables 3\*, 4\*, and 5\*.

\* Tables were taken from G. O. Carlson price list.

Table 1  
A.S.T.M. SPECIFICATIONS AND CHEMICAL COMPOSITIONS  
FOR AUSTENITIC STAINLESS STEEL PLATE

A.S.T.M. Spec. A240 Al67	Type	Chemical Composition, Per Cent										Other
		C Max.	Mn, P, S	Si	Cr	Ni	Other					
-	X	0.15	*	1.00	16.00-18.00	6.00-8.00						-
-	X	0.15	*	1.00	17.00-19.00	8.00-10.00						-
-	X	0.15	*	2.00-3.00	17.00-19.00	8.00-10.00						-
-	X	0.08	*	1.00	18.00-20.00	8.00-12.00						-
-	X	0.03	*	1.00	18.00-20.00	8.00-12.00						-
-	X	0.12	*	1.00	17.00-19.00	10.00-13.00						-
-	X	0.08	*	1.00	19.00-21.00	10.00-12.00						-
-	X	0.20	*	1.00	22.00-24.00	12.00-15.00						-
-	X	0.08	*	1.00	22.00-24.00	12.00-15.00						-
-	X	0.25	*	1.50	24.00-26.00	19.00-22.00						-
-	X	0.08	*	1.50	24.00-26.00	19.00-22.00						-
-	X	0.08	*	1.00	16.00-18.00	10.00-14.00						Mo 2.00-3.00
-	X	0.08	*	1.00	15.00-18.00	10.00-14.00						Mo 2.00-3.00
-	X	0.08	*	1.00	18.00-20.00	11.00-15.00						Mo 3.00-4.00
-	X	0.03	*	1.00	18.00-20.00	11.00-15.00						Mo 3.00-4.00
-	X	0.08	*	1.00	17.00-19.00	9.00-12.00						Ti 5 x C min. 0.70 max.
-	X	0.08	*	1.00	17.00-19.00	9.00-12.00						Ti 5 x C min. Cb+Ta 10 x C min.; 1.10 max.
-	X	0.08	*	1.00	17.00-19.00	9.00-13.00						Cb+Ta 10 x C min.; 1.10 max.; Ta 0.10 max. Co 0.20 max.

\* Mn 2.00 max.; P 0.045 max.; S 0.030 max.

Table 2  
 A.S.T.M. SPECIFICATIONS AND CHEMICAL COMPOSITIONS FOR  
 FERRITIC AND MARTENSITIC STAINLESS STEEL PLATE

A.S.T.M. Spec.		Chemical Composition, Per Cent									
A240	Al76	Type	C Max.	Mn, P, S	Si Max.	Cr	Ni Max.	Al	Other		
-	X	403	0.15	a	0.50	11.50-13.00	0.60	-	-		
X	X	405	0.08	a	1.00	11.50-14.50	0.60	Al 0.10	-		
X	X	410	0.15	a	1.00	11.50-13.50	0.75	-	-		
X	X	410S	0.08	a	1.00	11.50-13.50	0.60	-	-		
-	X	430	0.12	a	1.00	14.00-18.00	0.75	-	-		
X	-	430A	0.12	a	1.00	14.00-16.00	0.75	-	-		
X	-	430B	0.12	a	1.00	16.00-18.00	0.75	-	-		
-	X	442	0.35	b	1.00	18.00-23.00	0.60	-	-		
-	X	446	0.20	c	1.00	23.00-27.00	0.60	N 0.25	-		

a - Mn 1.00 max.; P 0.040 max.; S 0.030 max.

b - Mn 1.00 max.; P 0.040 max.; S 0.040 max.

c - Mn 1.50 max.; P 0.040 max.; S 0.030 max.

Table 3

**STAINLESS STEEL PLATE BASE PRICES AND EXTRAS**  
**LOW CARBON EXTRAS**

Subject to change without notice

Cents per pound

Type	Grade	Plates	Bars	Cold Fin. Wire 1/2" & Under	Sheets	Forging Billets
302	18-8	42.25	46.75	44.25	52.00	39.50
303	18-8 FM	45.00	49.75	47.25	—	42.50
304	18-8	42.25	46.75	44.25	52.00	39.50
304 L	18-8 ELC	50.00	54.50	52.00	59.75	47.25
305	18-11 FS	46.25	49.50	47.00	58.75	44.00
309	25-12	66.00	69.50	66.25	80.50	60.00
309 S	25-12	72.00	75.75	71.75	88.25	64.75
309 SCb	25-12 Cb-Ta	90.75	95.00	—	—	81.50
310	25-20	87.75	94.50	89.75	96.75	81.00
310 SCb	25-20 Cb	108.25	115.00	—	—	101.50
314	25-20 Si	87.75	94.50	89.75	—	80.50
316	18-12 Mo	71.75	75.75	71.75	80.75	64.50
316 L	18-12 MoELC	79.50	83.50	79.50	88.50	72.25
317	19-12 Mo	88.50	94.25	89.50	101.00	79.75
317 L	19-12 MoELC	96.25	102.00	97.25	108.75	87.50
318	18-8 MoCb-Ta	93.75	98.50	—	—	84.00
D319	D319	72.75	76.50	72.75	82.50	65.00
D319 L	D319 ELC	80.50	84.25	—	—	72.75
321	18-10 Ti	54.75	57.50	54.50	65.50	48.75
330	19-35	100.50	110.75	—	—	94.25
347	18-10 Cb-Ta	64.75	67.25	63.75	79.25	57.75
348	18-10 Cb	64.75	67.25	63.75	79.25	57.75
Armco	17-4 PH	101.25	78.75	74.75	107.00	71.25
Armco	17-7 PH	85.25	75.75	72.00	90.00	68.50
Armco	PH 15-7 Mo	111.25	96.50	92.75	116.00	89.25
405	12Al	32.50	36.50	34.75	46.75	30.75
410	12	30.00	31.50	29.75	40.25	26.75
430	17	31.00	35.50	33.75	40.75	29.75
502	5 Mo	28.25	25.50	—	—	23.50

If low carbon content is specified or required on Types other than 302, 304L, 316L, 317L, and D319L, the following extras are applicable in addition to the appropriate Base Price:

.03 max.	7.75
.04 max.	5.75
.05 max.	3.50
.06 max.	2.25

**ALLOY ADDITION EXTRAS**

Silicon	1.00% to 2.00%	1.75
Vanadium	0.10% to 0.20%	2.25
Aluminum	0.25% to 1.00%	2.25
	Over 1.00% to 2.00% incl.	4.25
*Titanium	0.10% to 0.50% max.	3.50
	Over 0.50% to 0.70%	6.00
*Columbium	Columbium-Tantalum—10 times Carbon min.	20.50
	Columbium—10 times Carbon min. Ta 0.10 max.	20.50
Cobalt	0.05% max.	5.00
Molybdenum	Type 502	All Other Types
	0.40% to 0.65%	None
	0.66% to 1.00%	1.75
	1.01% to 2.00%	3.50

\*When Columbium or Titanium alloy addition is specified for the Type 500 series, the Type 502 base price will apply, plus the above extras.

**SPECIAL CHROMIUM CONTENT EXTRAS**

The following extras are to be charged when the chromium content is in excess of the mean of 4 to 6%. The extra to be applied for each per cent of chromium or part thereof, up to a mean of 8%, is to be selected according to the carbon content of the steel:

Carbon over 0.10%	1.75
Carbon 0.10% maximum	2.00

Table 4

STAINLESS STEEL PLATE PRICE EXTRAS

**TESTING EXTRAS**

Tensile and/or Hardness Test at Room Temperature .....	None
Tensile Test at -320° F	
First Test (one specimen) .....	\$ 70.00
Each Additional Test (one specimen) on same order .....	\$ 40.00
Tensile and/or Hardness Test—Heat Treated Specimen	
Single Heat Treatment—17-4 PH* .....	\$ 13.50
Double Heat Treatment—17-7 PH* and PH 15-7 Mo* .....	\$ 27.75
Bend Test .....	None
Charpy Impact Test (Average of 3 specimens)	
Room Temperature .....	\$ 33.60
0° F to -100° F .....	\$ 36.75
Under -100° F to -320° F .....	\$ 51.75
At -423° F	
First Test (Average of 3 specimens) .....	\$ 225.00
Each Additional Test on same order .....	\$ 115.00
Intergranular Corrosion (Strauss) Test .....	None
Boiling Nitric Acid (Huey) Test .....	None
Check Analysis—Major Elements—No Residuals .....	\$ 33.25
Check Analysis—Single Element .....	\$ 6.75
Check Analysis—Residual Elements in PH Grades	
Cobalt .....	\$15.00
Columbium (except 17-4 PH) ..	15.00
Nitrogen .....	20.00
Vanadium .....	15.00
Other elements on application.	
Grain Size Determination (For information only) .....	None
Macro-etch—extra applies only to the PH grades of bar, and to rings and discs of any grade. Extra to be charged, when applicable, depends on size and cross-section of sample but \$6.75 minimum .....	Applies
Ultrasonic Inspection—Plates (See Page 10) .....	Applies
Ultrasonic Inspection—Bars and Forgings (See Page 26) .....	Applies
Liquid Penetrant Inspection—Plate (See Page 11) .....	Applies
Liquid Penetrant Inspection—Bars and Forgings (See Page 26) .....	Applies

For tests listed above that carry no extra, the mill reserves the right to make a charge when more than one test per lot is required.

\*Trademark of Armco Steel Corporation. These grades are supplied in the annealed condition. When reports of tensile and/or hardness tests in the heat treated condition are required, these charges apply.

**ULTRASONIC QUALITY AND TESTING EXTRAS**

Applies to plates subject to rejection by, or as a result of ultrasonic testing.  
 Ultrasonic Quality Extra .... 10% of base price applicable to type or grade ordered.  
 Ultrasonic Testing of finished plate  
 (Straight beam or angle beam) ..... 25.00 cents per sq. ft. of plate area.  
 Minimum Charge \$110.50.

When ultrasonic testing is performed at our plant straight beam (longitudinal wave) testing on 100% of the surface from one side will normally be used. Plates furnished to this quality shall be free from discontinuities giving ultrasonic indication exceeding that obtained from a ¼ inch diameter flat-bottomed hole contained in a stainless steel reference plate prepared at the plant.

When angle beam (shear wave) testing is employed, plates furnished to this quality shall be free from discontinuities giving ultrasonic indications exceeding that produced from an indented notch the depth of which is 3% of the thickness of the material being tested or ultrasonic indications exceeding that obtained from a ⅛ inch diameter hole drilled parallel with the surface of a plate.

More restricted standards of acceptance will be subject to negotiation.

In addition, if complete loss of back reflection is encountered which cannot be attributed to surface condition or grain size, the plate will not be considered ultrasonic quality.

On plates that are not ordered to Ultrasonic Quality, but subsequently tested by Ultrasonic methods, rejections will not be considered for internal discontinuities beyond three inches from the plate edges.

**SURFACE INSPECTION BY PENETRANTS**

Surface Inspection by Penetrant Methods will be performed when specified at an extra of 12.00¢ per sq. ft. of surface inspected. Minimum Charge .....\$15.50

Visible surface defects will be removed by grinding prior to performing surface inspection by penetrant testing. The removal by grinding of surface openings detected by penetrant testing will be subject to negotiation with customer's representative.

**CLEANING EXTRA**

A final cleaning operation prior to shipment is recommended on all plates surface inspected by penetrants. This cleaning is necessary to remove penetrant from plate surface and will be performed unless otherwise specified. The following extras apply for this added operation:

Under ⅜" thickness .....	3.00
⅜" and heavier thickness .....	2.75

Table 5

STAINLESS STEEL PLATE PRICE EXTRAS

WIDTH, THICKNESS AND FINISH EXTRAS  
HOT ROLLED ONLY

THICKNESS Inches	WIDTH—Inches			Over 96
	Over 6* to 36 excl.	36 to 48 excl.	48 to 96 incl.	
3/16 to 1/4 excl. . . . .	11.50	8.25	5.25	8.00
1/4 to 3/8 excl. . . . .	8.25	5.25	3.00	5.25
3/8 to 1/2 excl. . . . .	4.00	2.75	1.75	2.50
1/2 to 3/4 excl. . . . .	1.25	.75	.25	.50
3/4 to 1 1/2 excl. . . . .	1.25	.75	None	.25

HOT ROLLED ANNEALED

THICKNESS Inches	WIDTH—Inches			Over 96
	Over 6* to 36 excl.	36 to 48 excl.	48 to 96 incl.	
3/16 to 1/4 excl. . . . .	14.25	11.00	8.00	10.75
1/4 to 3/8 excl. . . . .	11.00	8.00	5.75	8.00
3/8 to 1/2 excl. . . . .	6.75	5.50	4.50	5.25
1/2 to 3/4 excl. . . . .	4.00	3.50	3.00	3.25
3/4 to 1 1/2 excl. . . . .	4.00	3.50	2.75	3.00

HOT ROLLED ANNEALED & PICKLED

THICKNESS Inches	WIDTH—Inches			Over 96
	Over 6* to 36 excl.	36 to 48 excl.	48 to 96 incl.	
3/16 to 1/4 excl. . . . .	17.25	14.00	11.00	13.75
1/4 to 3/8 excl. . . . .	14.00	11.00	8.75	11.00
3/8 to 1/2 excl. . . . .	9.50	8.25	7.25	8.00
1/2 to 3/4 excl. . . . .	6.75	6.25	5.75	6.00
3/4 to 1 1/2 excl. . . . .	6.75	6.25	5.50	5.75

\*Widths over 6 inches through 10 inches (formerly sold as bars) will be sold as plates to appropriate plate tolerances. Widths 6 inches and under take Bar Base and Extras.

LENGTH EXTRAS

Under 96" . . . . .	1.75	96" and over . . . . .	None
---------------------	------	------------------------	------

ITEM QUANTITY EXTRAS

Item quantity extras are determined by the total weight of a size (one thickness and one width) of one grade and treatment or finish, ordered at one time for shipment at one time. Shipments may go to various destinations.

15,000 lbs. and over . . . . .	None	Under 3,000 lbs. to 2,000 lbs. . . . .	13.75
Under 15,000 lbs. to 12,000 lbs. . . . .	.75	Under 2,000 lbs. to 1,000 lbs. . . . .	17.00
Under 12,000 lbs. to 9,000 lbs. . . . .	2.75	Under 1,000 lbs. to 500 lbs. . . . .	20.50
Under 9,000 lbs. to 6,000 lbs. . . . .	6.75	Under 500 lbs. to 300 lbs. . . . .	24.50
Under 6,000 lbs. to 3,000 lbs. . . . .	10.25	Under 300 lbs. . . . .	25.00

ORDER QUANTITY EXTRAS  
(None)

CUTTING EXTRAS

RECTANGULAR PLATES

Plates heavier than 1" cannot be sheared and must be cut by one of the following methods. Orders should specify the cutting method preferred. Square and rectangular plates over 1" in thickness will be abrasive cut to size on all four edges unless otherwise specified.

	Per square inch of cut		
	Machining	Abrasive Cutting	Flame Cutting
Up to 48" perimeter, incl. . . . .	26.50	12.00	10.00
Over 48" to 240" perimeter, incl. . . . .	20.25	8.50	6.75
Over 240" perimeter . . . . .	15.50	7.25	5.75

SHEARED CIRCLE EXTRA

24" diameter and larger:

Add 3 3/4% to the price of the square plate having the same dimensions as the diameter of the circle, including all extras except those for Ultrasonic Quality, including testing where applicable; Surface Inspection by Penetrants, including cleaning where applicable; Packing and Marking. The resulting price applies to the billing weight of the circle. Quantity extra for circles shall be based on the rectangular weight of the diameter of the circle.

Under 24" diameter: on application.

CIRCLE CUTTING

Circular plates over 3/8" thick cannot be circle sheared and must be flame cut or machined. Orders should specify the method preferred. The following extras apply to circles based on circumference times thickness of the individual plate:

	Per square inch of cut	
	Machining	Flame Cutting
Under 24" diameter . . . . .	Inquire	Inquire
24" to 72" diameter, incl. . . . .	11.75	6.25
Over 72" to 120" diameter, incl. . . . .	10.75	5.25
Over 120" diameter . . . . .	On application, but not less than 10.75	5.25

The thickness ordered or required will be furnished to the Thickness Tolerances for Stainless Plates listed on Page 11 and the applicable plate billing weight will be determined from the table of Plate Billing Weights shown on Page 6.

RECOMMENDED FLAME CUTTING ALLOWANCES FOR EDGE CLEAN UP

Plates up to 2" thick, inclusive—1/4" allowance per edge  
 Plates over 2" to 3" thick, inclusive—3/8" allowance per edge  
 Plates over 3" to 6" thick, inclusive—1/2" allowance per edge  
 Plates over 6" thick—Inquire

Table 6  
STAINLESS STEEL PLATE PRICE EXTRAS AND THICKNESS TOLERANCES

**SKETCHES**

Charge shall be the selling price computed from the Plate Billing Weight of the most economical rectangular plate from which one or more such sketches can be cut. Price will include all extras for the size and finish of the rectangular plate used to obtain the sketch. When sketches are to be Flame Cut and the finished machined plate dimensions are known the appropriate flame cutting allowance for cleaning up, will be included in determining the size of the rectangular plate.

The thickness ordered or required will be furnished to the Thickness Tolerances for Stainless Plates and the applicable plate billing weight will be determined from the table of Plate Billing Weights

	<b>PACKING EXTRAS</b>	
Boxing .....		2.00
(Minimum charge .....	\$10.00)	
Skidding .....		1.25
(Minimum charge .....	\$ 5.75)	

**ADHESIVE PAPER PER SIDE**

$\frac{3}{16}$ " and thicker ..... 1.50  
This extra applies in addition to regular packing charge.

**CONTINUOUS LINE MARKING**

$\frac{3}{16}$ " and thicker ..... .75

**SPECIAL FLATTENING**

For closer than commercial tolerance based on rectangular weight of plate ..... 1.75

**THICKNESS TOLERANCES**

All plates must be ordered to thickness and not to weight per square foot. For purposes of production and shipment of plates within production size ranges, the Thickness Tolerances for Stainless Steel Plates shown below apply.

Specified Thickness — Inches	Thickness Tolerance — Over Variation,* Inches	
	Widths to 84", Incl.	Widths Over 84" to 120", Incl.
$\frac{3}{16}$ to $\frac{1}{4}$ , excl. ....	.046	.050
$\frac{3}{8}$ to $\frac{1}{2}$ , excl. ....	.054	.058
$\frac{3}{4}$ to 1, excl. ....	.060	.064
1 to 2, incl. ....	.070	.074
Over 2 .....	inquire	inquire

\*No plate shall vary more than 0.01" under the thickness ordered.  
Spot grinding not to exceed 0.01" under the specified thickness is permitted to remove surface imperfections.

Plate weights as shown in Table under Plate Billing Weights on Page 6 will be used for billing purposes. Plate weights for thicknesses other than those shown will be furnished upon inquiry and will be used for billing purposes.

Table 7

PLATE TOLERANCES

SHEARED PLATES  
UNIVERSAL MILL PLATES

PLATES  
CIRCLE SHEARING LIMITS

Thickness—Inches	Min. Diameter	Max. Diameter
3/16 to 1/4 incl.	12"	189"
Over 1/4 to 3/8 incl.	20"	189"
Over 3/8 to 3/2 incl.	24"	189"

DIAMETER TOLERANCES  
CIRCULAR PLATES

Specified Diameter Inches	Permissible variation over specified diameter for thicknesses given — inch		
	To 3/4 excl.	3/4 to 3/2 excl.	3/2 and over*
To 60, excl.	3/4	3/8	1/2
60 to 84, excl.	5/16	7/16	3/8
84 to 108, excl.	3/8	1/2	3/8
108 to 130, excl.	7/16	3/4	11/16

No permissible variation under.

\*Circular and sketch plates over 3/4" in thickness are not commonly sheared and are machined or otherwise cut. (See Page 9.)

SHEARED OR UNIVERSAL MILL PLATES—CAMBER

1/8 in. X  
Number of feet of length  
5

ANNEALED PLATES  
FLATNESS

Specified Thickness Inches	Variations from a flat surface for thickness and widths given — inches										
	48 or under	48 excl. to 60	60 excl. to 72	72 to 84, excl.	84 to 96, excl.	96 to 108, excl.	108 to 120, excl.	120 to 144, excl.	144 and over		
3/16 to 1/4, excl.	3/4	1 1/16	1 1/4	1 3/8	1 5/8	1 7/8	1 9/8	1 11/8	1 1 1/4	1 1 1/2	1 1 3/4
1/4 to 3/8, excl.	1 1/16	1 1/8	1 1/4	1 1/2	1 5/8	1 7/8	1 9/8	1 11/8	1 1 1/4	1 1 1/2	1 1 3/4
3/8 to 1/2, excl.	1 1/4	1 1/2	1 3/4	1 5/8	1 7/8	1 9/8	1 11/8	1 1 1/4	1 1 1/2	1 1 3/4	1 1 3/4
1/2 to 3/4, excl.	1 1/2	1 3/4	1 5/8	1 7/8	1 9/8	1 11/8	1 1 1/4	1 1 1/2	1 1 3/4	1 1 3/4	1 1 3/4
3/4 to 1, excl.	1 3/4	1 5/8	1 7/8	1 9/8	1 11/8	1 1 1/4	1 1 1/2	1 1 3/4	1 1 3/4	1 1 3/4	1 1 3/4
1 to 1 1/4, excl.	1 5/8	1 7/8	1 9/8	1 11/8	1 1 1/4	1 1 1/2	1 1 3/4	1 1 3/4	1 1 3/4	1 1 3/4	1 1 3/4
1 1/4 to 4, excl.	1 7/8	1 9/8	1 11/8	1 1 1/4	1 1 1/2	1 1 3/4	1 1 3/4	1 1 3/4	1 1 3/4	1 1 3/4	1 1 3/4
4 to 6, excl.	1 3/4	1 5/8	1 7/8	1 9/8	1 11/8	1 1 1/4	1 1 1/2	1 1 3/4	1 1 3/4	1 1 3/4	1 1 3/4

Permissible variations in above table apply to plates up to 15 ft. length, or to any 15 ft. of longer plates.  
If the longer dimension is under 36 in. the permissible variation shall not be greater than 1/4 in.

The shorter dimension specified shall be considered the width and the permissible variation in flatness across the width shall not exceed the tabular amount for that dimension.

The maximum deviation from a flat surface does not customarily exceed the tabular tolerance for the longer dimension specified.

The above flatness tolerances are not applicable to plates in the hot rolled condition or to plates with physicals other than fully annealed.

If flatness closer than the above tolerances is required, there will be an extra charge for special flattening. Closer than standard flatness tolerances should be taken up with the mill.

WIDTH AND LENGTH TOLERANCES

Specified dimensions Inches	Variations in inches over specified width and length for thicknesses										
	Under 3/4		3/4 to 1/2 incl.		Over 1/2*						
Widths	Lengths	Width	Length	Width	Length	Width	Length	Width	Length	Width	Length
48 and under	144 and Under	1/8	3/16	3/16	1/4	5/16	3/8	5/16	3/8	3/8	7/16
Over 48 to 60 incl.		3/16	1/4	1/4	3/8	5/16	3/8	3/8	1/2	3/8	1/2
Over 60 to 84 incl.		1/4	5/16	5/16	3/8	7/16	1/2	3/8	1/2	3/8	9/16
Over 84 to 108 incl.		5/16	3/8	3/8	7/16	1/2	5/8	1/2	1 1/16	3/8	1 1/16
Over 108		3/8	7/16	7/16	1/2	5/8	1 1/16	1/2	1 1/16	3/8	1 1/16
48 and under	Over 144 to 240	3/16	1/4	1/4	1/2	5/16	3/8	5/16	3/8	3/8	7/16
Over 48 to 60 incl.		1/4	5/16	5/16	3/8	7/16	1/2	3/8	1/2	3/8	9/16
Over 60 to 84 incl.		3/8	7/16	7/16	1/2	5/8	3/4	3/8	1/2	3/8	1 1/16
Over 84 to 108 incl.		7/16	1/2	1/2	3/4	5/8	3/4	3/8	1 1/16	3/8	1 1/16
Over 108		1/2	5/8	5/8	3/4	7/8	1 1/16	3/4	1 1/16	3/8	1 1/16
48 and under	Over 240 to 360	1/4	5/16	5/16	3/8	7/16	1/2	3/8	1/2	3/8	9/16
Over 48 to 60 incl.		5/16	3/8	3/8	1/2	5/8	3/4	3/8	1/2	3/8	9/16
Over 60 to 84 incl.		7/16	1/2	1/2	3/4	5/8	3/4	3/8	1/2	3/8	9/16
Over 84 to 108 incl.		5/8	3/4	3/4	1 1/16	7/8	1 1/16	3/4	1 1/16	3/8	1 1/16
Over 108		3/4	7/8	7/8	1 1/16	1 1/16	1 1/16	3/4	1 1/16	3/8	1 1/16
60 and under	Over 360 to 480	7/16	1/2	1/2	1 1/4	5/8	3/4	3/8	1 1/4	3/8	1 1/4
Over 60 to 84 incl.		1/2	3/4	3/4	1 1/2	7/8	1 1/2	3/4	1 1/2	3/8	1 1/2
Over 84 to 108 incl.		5/8	3/4	3/4	1 3/4	7/8	1 3/4	3/4	1 3/4	3/8	1 3/4
Over 108		3/4	7/8	7/8	1 1/2	1 1/2	1 1/2	3/4	1 1/2	3/8	1 1/2
60 and under	Over 480 to 600	7/16	1/2	1/2	1 1/2	5/8	3/4	3/8	1 1/2	3/8	1 1/2
Over 60 to 84 incl.		1/2	3/4	3/4	1 1/2	7/8	1 1/2	3/4	1 1/2	3/8	1 1/2
Over 84 to 108 incl.		5/8	3/4	3/4	1 3/4	7/8	1 3/4	3/4	1 3/4	3/8	1 3/4
Over 108		3/4	7/8	7/8	1 1/2	1 1/2	1 1/2	3/4	1 1/2	3/8	1 1/2
60 and under	Over 600 to 1000	1/2	3/4	3/4	1 1/2	5/8	3/4	3/8	1 1/2	3/8	1 1/2
Over 60 to 84 incl.		3/4	7/8	7/8	1 1/2	7/8	1 1/2	3/4	1 1/2	3/8	1 1/2
Over 84 to 108 incl.		5/8	3/4	3/4	1 3/4	7/8	1 3/4	3/4	1 3/4	3/8	1 3/4
Over 108		3/4	7/8	7/8	1 1/2	1 1/2	1 1/2	3/4	1 1/2	3/8	1 1/2

\*Permissible variation under specified width and length, 1/4 inch.

Plates heavier than 1" cannot be sheared and must be machined or otherwise cut.

Table 8

PLATE MACHINING ALLOWANCES AND BILLING WEIGHTS

PLATES

All plates must be ordered to thickness and not to weight per square foot. Thicknesses under 3/16" take Sheet or Strip Classification. Widths 6" and under, thicknesses 3/16" and heavier take Bar Classification.

ALLOWANCES FOR SURFACE MACHINING

Thickness Over 2 Inches

The following table shows the allowances which must be added to the finished thickness in order to insure the desired minimum thickness after surface machining. Plate orders must indicate whether surface finishing is involved and if so whether finishing allowance has been added.

Thickness Clean-up Allowances for Plates Over 2" Thick to be Added to Minimum Desired Plate Thickness

Condition	Width	Thickness	Plates up to 120" long incl.	Plates over 120" long incl.
(1) One surface to be machined.	Under 30" 30" to 60" incl. Over 60" to 90" incl. Over 90" to 120" incl.	Over 2" to 8" incl.	Inquire	Inquire
		Over 2" to 8" incl.	3/16"	5/16"
		Over 2" to 8" incl.	1/4"	7/16"
(2) Two surfaces to be machined.	Under 30" 30" to 60" incl. Over 60" to 90" incl. Over 90" to 120" incl.	Over 2" to 8" incl.	Inquire	Inquire
		Over 2" to 8" incl.	1/4"	3/8"
		Over 2" to 8" incl.	5/16"	1/2"
(3) A pickled product is recommended for purposes other than machining; plates may be ground locally or over-all on both surfaces to provide removal of surface defects.	All Widths All Widths	Over 2" to 4" incl.	1/16"	1/8"
		Over 4" to 8" incl.	1/8"	1/4"

The above allowances for plates to be machined are based on special flattening at the mill. The special flattening extra of 1.75¢ will apply based on the rectangular weight of the plate before surface machining.

PLATE BILLING WEIGHTS

The following table shows the plate weights for various commonly ordered plate thicknesses which will be used for billing purposes. Plate weights for thicknesses under 2" which are other than shown below will be furnished upon inquiry. Plates over 2" thick will be sold on an average weight per square foot basis using 42.582 lbs. per square foot per inch of thickness on plates which are 96" and under in width and 43,202 lbs. per square foot per inch of thickness on plates over 96" wide, to determine plate billing weights. Plates will be billed at these weights, therefore, it is recommended that these weights be used for estimating purposes.

U.S. Std. Gage	Decimal Thickness	Fraction of an Inch	Billing Weight (Pounds Per Square Foot)		
			Widths Up to and Incl. 84"	Width Over 84" to 96" Incl.	Widths Over 96"
7	.1875	3/16	7.985	8.295	8.566
6	.2031	5/32	8.650	8.984	9.280
5	.2187	3/16	9.315	9.677	9.994
4	.2343	1/4	9.981	10.369	10.707
3	.2500	1/4	10.646	10.956	11.266
2	.2656	1/4	11.310	11.641	11.969
1	.2812	5/16	11.977	12.442	12.675
	.3125	5/16	13.308	13.437	13.695
	.3437	1/2	14.637	14.779	15.064
	.3750	3/8	15.968	16.123	16.433
	.4062	1/2	17.299	17.467	17.803
	.4375	1/2	18.630	18.810	19.172
	.4687	1/2	19.960	20.155	20.542
	.5000	1/2	21.291	21.498	21.911
	.5312	15/32	22.843	22.843	23.282
	.5625	3/8	24.185	24.185	24.650
	.5937	3/8	25.530	25.530	26.020
	.6250	1/2	26.614	26.614	27.002
	.6562	1/2	27.946	27.946	28.353
	.6875	11/16	29.276	29.276	29.702
	.7187	3/4	30.607	30.607	31.052
	.7500	3/4	31.937	31.937	32.402
	.7812	3/4	33.269	33.269	33.752
	.8125	3/4	34.599	34.599	35.103
	.8437	7/8	35.931	35.931	36.452
	.8750	7/8	37.260	37.260	37.803
	.9062	7/8	38.592	38.592	39.152
	.9375	15/16	39.922	39.922	40.503
	.9687	15/16	41.254	41.254	41.852
	1.0000	1	42.582	42.582	43.202
	1.0625	1 1/16	45.244	45.244	45.903
	1.1250	1 1/8	47.905	47.905	48.603
	1.1875	1 1/4	50.567	50.567	51.303
	1.2500	1 1/2	53.228	53.228	54.004
	1.3125	1 3/8	55.890	55.890	56.704
	1.3750	1 3/4	58.550	58.550	59.403
	1.4375	1 7/8	61.211	61.211	62.103
	1.5000	1 7/8	63.871	63.871	64.804
	1.5625	1 7/8	66.533	66.533	67.504
	1.6250	1 7/8	69.190	69.190	70.204
	1.6875	1 7/8	71.858	71.858	72.904
	1.7500	1 7/8	74.519	74.519	75.605
	1.8125	1 7/8	77.181	77.181	78.305
	1.8750	1 7/8	79.843	79.843	81.005
	1.9375	1 7/8	82.504	82.504	83.706
	2.0000	2	85.164	85.164	86.405

Table 9

MILL SIZE LIMITATIONS VS. STAINLESS STEEL TYPE

TYPES 302, 304, 304L, 321, 405, 410, 430, 502†

MAXIMUM LENGTHS FOR WIDTHS AND THICKNESSES LISTED

Thickness, inches	WIDTHS, Inches													
	To 40 incl.	Over 40 to 50 incl.	Over 50 to 60 incl.	Over 60 to 70 incl.	Over 70 to 80 incl.	Over 80 to 90 incl.	Over 90 to 100 incl.	Over 100 to 110 incl.	Over 110 to 120 incl.	Over 120 to 130 incl.	Over 130 to 140 incl.	Over 140 to 150 incl.	Over 150 to 160 incl.	Over 160 to 170 incl.
3/16 to 1/4, excl.	600	600	600	600	550	500	*							
1/4 to 5/16, "	650	650	650	650	600	550	500							
5/16 to 3/8, "	650	650	650	650	600	600	525							
3/8 to 1/2, "	650	650	650	650	600	575	525	500	450	425	350	350		
1/2 to 5/8, "	650	650	650	600	600	575	525	500	450	400	375	350	325	325
5/8 to 3/4, "	625	625	625	600	600	575	525	500	450	400	375	350	325	325
3/4 to 1, "	625	600	600	600	600	575	550	500	450	400	400	350	300	300
1 to 1 1/4, "	600	600	600	550	550	550	525	500	450	400	375	350	300	300
1 1/4 to 1 1/2, "	600	600	600	550	550	550	500	450	450	400	375	350	300	300
1 1/2 to 1 3/4, "	600	600	600	550	550	500	500	450	450	400	375	350	300	300
1 3/4 to 2, "	525	450	450	450	450	450	450	425	400	400	350	300		
2 to 2 1/4, "	500	450	450	450	450	450	450	425	400	400	350	300		
2 1/4 to 2 1/2, "	450	450	450	450	450	450	400	400	400	350	300	300		
2 1/2 to 2 3/4, "	425	425	425	450	450	400	400	400	350	350	300	300		
2 3/4 to 3, "	400	400	400	400	400	375	350	350	325	300	275			
3 to 3 1/2, "	400	400	400	400	400	375	350	325	325	300	275			
3 1/2 to 4, "	350	350	350	350	350	350	325	300	300	275	250			
4 to 4 1/2, "	300	300	300	300	300	275	275	250	250	225	200			
4 1/2 to 5, "	250	250	250	250	250	250	225	225	225	200	200			
5 to 5 1/2, "	250	250	250	250	250	225	225	200	200	175	175			
5 1/2 to 6, "	225	225	225	200	200	200	200	175	175	150	150			
6 to 6 1/2, "	225	225	225	200	200	200	200	175	175	150	150			
6 1/2 to 7, "	200	200	200	200	200	200	175	175	150	150	150			
7 to 7 1/2, "	200	200	200	200	200	175	175	150	150	150	150			
7 1/2 to 8, "	200	200	200	175	175	175	150	150	150	125				
8 to 8 1/2, "	200	200	175	175	175	150	150	150	125					
8 1/2 to 9, "	200	175	175	175	150	150	150	125						
9 to 9 1/2, "	175	175	175	150	150	150	125							
9 1/2 to 10, incl.	175	175	175	150	150	125	125							
Over 10	150	125	125	100	100									

\*Can be made 96" wide up to 480" long. Plates over 480" long cannot be annealed.  
 †For single plates over 9400 lbs.—inquire. Plates over 456" long cannot be pickled.

TYPES 309, 316, 316L, D319, D319L, 347, 348 (17-4PH, 17-7PH, PH15-7Mo)†

MAXIMUM LENGTHS FOR WIDTHS AND THICKNESSES LISTED

Thickness, inches	WIDTHS, Inches													
	To 40 incl.	Over 40 to 50 incl.	Over 50 to 60 incl.	Over 60 to 70 incl.	Over 70 to 80 incl.	Over 80 to 90 incl.	Over 90 to 100 incl.	Over 100 to 110 incl.	Over 110 to 120 incl.	Over 120 to 130 incl.	Over 130 to 140 incl.	Over 140 to 150 incl.	Over 150 to 160 incl.	Over 160 to 170 incl.
3/16 to 1/4, excl.	550	550	550	550	450	400	*							
1/4 to 5/16, "	600	600	600	600	525	450	*							
5/16 to 3/8, "	600	600	600	600	550	500	450							
3/8 to 1/2, "	600	600	600	600	550	500	450	425	400	375	300	275		
1/2 to 5/8, "	600	600	600	600	525	500	450	400	400	350	350	300	250	250
5/8 to 3/4, "	600	600	600	575	525	500	425	400	375	350	300	275	250	250
3/4 to 1, "	600	600	550	550	525	450	400	375	375	350	300	275	250	225
1 to 1 1/4, "	550	550	550	525	450	450	400	375	350	350	300	275		
1 1/4 to 1 1/2, "	550	500	500	450	450	400	400	375	350	300	275	250		
1 1/2 to 1 3/4, "	550	500	500	450	375	375	350	300	300	300	275	250		
1 3/4 to 2, "	450	400	400	400	350	325	325	300	300	275	250			
2 to 2 1/4, "	400	400	400	350	350	325	300	300	275	250	250			
2 1/4 to 2 1/2, "	350	350	300	325	325	300	300	300	275	250	250			
2 1/2 to 2 3/4, "	300	300	300	325	325	300	300	275	275	250	250			
2 3/4 to 3, "	300	275	250	300	300	300	275	275	275	225				
3 to 3 1/2, "	300	260	220	300	300	300	275	275	250	225				
3 1/2 to 4, "	280	225	225	300	300	275	275	250	225					
4 to 4 1/2, "	250	250	250	275	275	250	250	225	200					
4 1/2 to 5, "	220	200	200	250	250	200	200	175	150					
5 to 5 1/2, "	200	200	200	250	200	175	175	150	150					
5 1/2 to 6, "	180	180	180	175	175	175	150	150						
6 to 6 1/2, "	165	165	165	175	175	150	150	125						
6 1/2 to 7, "	150	150	150	175	175	175	150	150	150					
7 to 7 1/2, "	140	140	140	175	175	150	125							
7 1/2 to 8, "	130	120	125	150	150	150	125							
8 to 8 1/2, "	125	120	120	150	150	125	125							
8 1/2 to 9, "	125	120	110	150	125	125								
9 to 9 1/2, "	125	100	100	125	125									
9 1/2 to 10, incl.	125	100	100	125	125									
Over 10	115	100	100	100										

\*Can be made 96" wide up to 480" long, except types 347 and 348. Plates over 480" long cannot be annealed.  
 †For single plates over 9400 lbs.—inquire. Plates over 456" long cannot be pickled.

Table 10

MILL SIZE LIMITATIONS VS. STAINLESS STEEL TYPE

TYPES 309Sb, 310, 310Sb, 317, 317L, 318

MAXIMUM LENGTHS FOR WIDTHS AND THICKNESSES LISTED

Thickness, inches	WIDTHS, inches													
	To 40 incl.	Over 40 to 50 incl.	Over 50 to 60 incl.	Over 60 to 70 incl.	Over 70 to 80 incl.	Over 80 to 90 incl.	Over 90 to 100 incl.	Over 100 to 110 incl.	Over 110 to 120 incl.	Over 120 to 130 incl.	Over 130 to 140 incl.	Over 140 to 150 incl.	Over 150 to 160 incl.	Over 160 to 170 incl.
3/16 to 1/4, excl.	480	480	480	480										
1/4 to 5/16, "	480	480	480	480	480									
5/16 to 3/8, "	480	480	480	450	400									
3/8 to 1/2, "	480	480	480	450	400	350	300	250	225					
1/2 to 5/8, "	480	480	480	450	450	400	350	300	275	255	235	220	200	195
5/8 to 3/4, "	480	480	480	450	450	400	350	300	275	255	235	220	200	195
3/4 to 1, "	450	450	450	425	425	400	350	300	275	250	225	200	200	
1 to 1 1/4, "	450	450	450	425	425	400	350	300	275	250	225	200		
1 1/4 to 1 1/2, "	450	450	450	425	425	400	350	300	275	250	225			
1 1/2 to 1 3/4, "	400	400	400	400	400	400	350	300	275	250	225			
1 3/4 to 2, "	325	325	325	325	325	300	300	275	275	250				
2 to 2 1/4, "	325	325	325	325	325	300	300	275	275	250				
2 1/4 to 2 1/2, "	325	325	325	325	325	300	300	275	250					
2 1/2 to 2 3/4, "	325	325	325	325	300	300	300	250	250					
2 3/4 to 3, "	300	300	300	300	300	275	275	250	225					
3 to 3 1/2, "	300	300	300	300	300	275	250	225	225					
3 1/2 to 4, incl.	300	300	300	300	300	275	250	225						

Plates over 480" long cannot be annealed.  
Plates over 456" long cannot be pickled.

10. - 10.1

## 10. MISCELLANEOUS INFORMATION

### 10.1 Galling Characteristics

Although it is known that the austenitic stainless steels are highly susceptible to galling or seizure when surfaces of the material are moved over one another under load, there is little published information available on the subject. The article reproduced as Exhibit 1 reports data obtained in tests conducted by Armco Steel Corporation. Since the article in question was written several years ago, Armco was requested to supply information on tests conducted since that date and to give information on stainless steel combinations not shown on the chart. The additional information is given on page 3, Exhibit 1. Also shown on that page is a correlation of A.I.S.I. stainless steel types with the designations used by Armco in reporting data.

Additional information developed by Goulds Pump Company and International Nickel Company and reported in American Machinist, August 12, 1957, is given in Exhibit 2. The section on stainless steels was taken from a larger chart which listed the galling resistance of many other metals and alloys.

By H. TANCZYN  
Armco Steel Corp.  
Middletown, O.

New testing method at Armco establishes galling load points for most stainless alloys. Graphical data will take the guesswork out of selecting proper steel

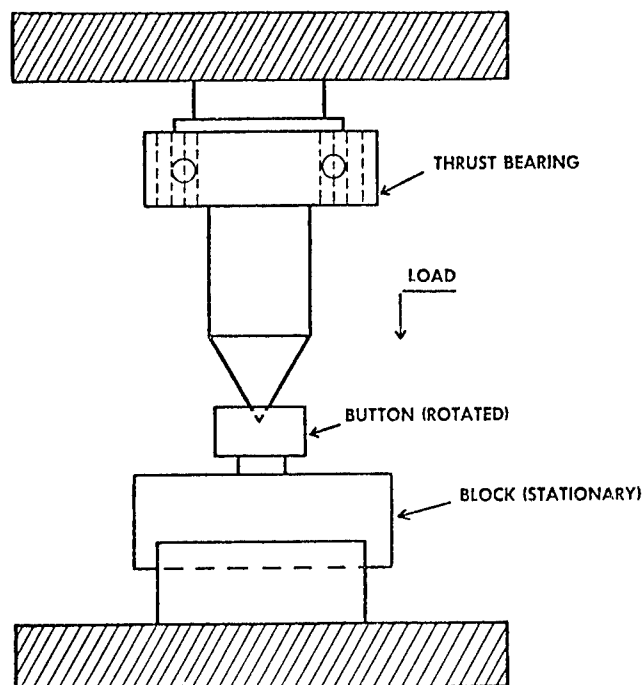

Arrangement for galling test shows how test blocks are loaded and rotated on the stationary block. Blocks are examined for galling after each turn

## Stainless Steel Galling Characteristics Checked

PREVENTION of galling and seizure of stainless steel surfaces moving over one another is a unique problem. Ordinary lubrication methods are not usually practicable for stainless equipment due to the hazards of product contamination. Yet, little published information has been available to manufacturers who have often applied stainless steels on the basis of their experience with carbon steels.

An investigation, conducted in the research laboratories of Armco Steel Corp., Middletown, O., developed both a testing method and the galling characteristics of various stainless steels. Work was limited to study of relatively slow and restricted movements of stainless steel surfaces over one another.

**Several Methods Tried**—Galling test described in this article was adopted after a number of methods involving the use of torque wrenches, strain gages, and nut and bolt assemblies had been stud-

ied. The polished base of a cylinder section is rotated under pressure against a polished block surface for one revolution. A series of assemblies is compressed under increasing loads until galling occurs.

Test specimens were cleaned with fresh acetone before testing. Loading control was adjusted to maintain constant load during rotation, but a slight drop-off usually occurred during tests. After testing, both specimens were examined for galling at 30 x magnification and the galling load converted to psi based on contact area. Data were reproducible to within 125 psi at loads under 1000 pounds and within 250 psi at higher loads.

**Surface Influence**—Where specimens were prepared with machined surfaces, results of the preliminary tests were not reproducible. With machined surfaces, one member of the assembly usually ploughed through the second piece

like a cutting tool. Small torn areas on machined surfaces locked together during testing to produce galling.

Test specimens finished with 3/0 metallographic polishing paper, however, gave reproducible data. More experimenting was done with smoother surfaces produced by polishing on cloth-covered wheels. But considerable difficulty was encountered in maintaining a plane surface on the specimens so the 3/0 paper finish was used for all further tests.

**Test Results**—The data obtained in the galling tests are summarized in the bar graphs. Brinell hardness values are given with the grade designation.

Influence of sulphur and selenium additions on the galling resistance of stainless steels is easily seen. The added sulphur and selenium reduce the frictional forces between the stainless steel specimens.

Merchant and Zlatin<sup>1</sup> report that the coefficient of friction for type 303-S stainless steel is about 76 per cent of that for type 304 stainless steel. Apparently the sulphides are smeared over the stainless steel surfaces to form a low shear strength film which interferes with the metal-to-metal contact.

**Hardness Is Factor**—Generally, stainless steel sections at a relatively high hardness level, or with a substantial difference in hardness, exhibit better resistance to galling than the combination of two soft members. Since there may be no change in chemical composition, this relationship between hardness and resistance to galling is probably due to the difference in mechanical properties of the hardened and soft specimen.

Here Bowden and Tabor<sup>2</sup> offer the explanation that the hardened sections deform elastically near the contact points under loading, while the softer, weaker pieces yield plastically for a significant distance beneath the contact points.

During movement, hardened surfaces may recover elastically with decrease in pressure and this motion tends to sever any metallic welding. Yet in the case of the soft specimens, the surfaces probably continue to adhere closely during the movement of the specimens with relatively little elastic recovery and separation.

**Some Oxides Good**—The exceptionally good resistance to galling exhibited by type 329 stainless steel is very likely traceable to a combination of a suitable oxide surface film and the hard backing. Oxide films significantly influence the galling characteristics of metals. Recent work reported in the literature<sup>3</sup> indicated that while a film of Fe<sub>3</sub>O<sub>4</sub> increased the resistance of mild steel to galling, a film of Fe<sub>2</sub>O<sub>3</sub> did not benefit the steel for this purpose.

A relatively new precipitation hardening stainless steel, Armco 17-4 PH, is considered to be a useful substitute for type 304 stainless steel in applications involving galling, particularly if used in two conditions to obtain the desired differential in hardness between components.

The data from these tests should

12 Cr, BHN 149 vs. 17-C-100, BHN 555	
12 Cr, BHN 375 vs. 17-C-100, BHN 555	
17 Cr, BHN 156 vs. 17 Cr, BHN 156	
17 Cr-FM, BHN 163 vs. 17 Cr-FM, BHN 163	
12 Cr-FM, BHN 156 vs. 12 Cr-FM, BHN 156	
12 Cr-FM, BHN 156 vs. 12 Cr-FM, BHN 273	
12 Cr-FM, BHN 156 vs. 12 Cr-FM, BHN 375	
12 Cr-FM, BHN 375 vs. 12 Cr-FM, BHN 375	
12 Cr-FM, BHN 156 vs. 17-C-100, BHN 555	
12 Cr-FM, BHN 375 vs. 17-C-100, BHN 555	
17-C-100, BHN 555 vs. 17-C-100, BHN 555	
17-C-100, BHN 555 vs. 17 Cr, BHN 156	
27-4-1, BHN 400 vs. 27-4-1, BHN 400	
27-4-1, BHN 400 vs. 18-8, BHN 140	
18-8, BHN 140 vs. 18-8, BHN 140	
18-8, BHN 140 vs. 18-8, BHN 302	
18-8, BHN 140 vs. 18-8, BHN 341	
18-8, BHN 206 vs. 18-8, BHN 341	
18-8, BHN 140 vs. 17-C-100, BHN 555	
18-12-3 Mo, BHN 152 vs. 18-12-3 Mo, BHN 152	
18-12-3 Mo, BHN 152 vs. 18-12-3 Mo, BHN 250	
16-2, BHN 250 vs. 16-2, BHN 250	
12 Cr, BHN 149 vs. 12 Cr, BHN 149	
12 Cr, BHN 375 vs. 12 Cr, BHN 375	
12 Cr, BHN 149 vs. 12 Cr, BHN 375	
18-8 FM-5e, BHN 170 vs. 18-8 FM-5e, BHN 170	
18-8 FM-5e, BHN 170 vs. 18-8 FM-5e, BHN 350	
18-8 FM-5e, BHN 350 vs. 18-8 FM-5e, BHN 350	
ARMCO 17-4 PH, BHN 280 vs. ARMCO 17-4 PH, BHN 280	
ARMCO 17-4 PH, BHN 400 vs. ARMCO 17-4 PH, BHN 400	
ARMCO 17-4 PH, BHN 280 vs. ARMCO 17-4 PH, BHN 400	
BRONZE, ROCKWELL F-65 vs. BRONZE, ROCKWELL F-65	*
BRONZE, ROCKWELL F-65 vs. CAST IRON, BHN 185	*
CAST IRON, BHN 185 vs. CAST IRON, BHN 185	
*NO GALLING-SPECIMENS DEFORMED UNDER LOAD	
5 10 15 20 25 30 35 40 45	
GALLING LOAD - PSI X 1000	

These data on the galling loads for the various alloys are reproducible to within 125 psi at loads under 1000 pounds and within 250 psi above that

be useful to manufacturers in selecting stainless steels for applications where galling occurs, especially in limited, relatively slow movement of stainless steels over one another, such as in valves and threaded assemblies.

REFERENCES

1. M. Eugene Merchant and Norman Zlatin. Basic Reasons for Good Machinability of "Free Machining" Steels. *Trans. Am. Soc. Metals* (1949) Vol. 41, p. 663
2. F. P. Bowden and D. Tabor: The Ploughing and Adhesion of Sliding Metals *Journ. of Applied Physics*. (1943) Vol. 14, p. 90
3. R. L. Johnson, D. Godfrey and E. E. Bisson: Friction of Solid Films on Steel and High Sliding Velocities. *NACA Technical Note No. 1578* April, 1948, p. 6

Correlation Between Stainless Steel Designations Employed  
in Par. 10.1, Exhibit 1 and A.I.S.I. Type Numbers

12 Cr	Type 410
12 Cr FM	Type 416
16-2	Type 431
17 Cr	Type 430
17 Cr FM	Type 430F
17-C-100	Type 440C
18-8	Type 302 or 304
18-12-3 Mo	Type 316
18-8-FM Se	Type 303 Se
27-4-1	Type 329

Additional Armco Information on Galling

The following information was received by letter from Armco on January 20, 1960:

The paper (Exhibit 1) covers practically all of the test data of this type that Armco has developed. Additional galling tests on 17-4 PH in heat treated conditions other than that shown in the paper have been performed, but the properties were no better than already listed. Armco has never performed any galling tests on Type 304 or 316 against Type 416 heat treated to 240 Brinell, but would predict that this combination would be better than either Type 304 or 316 in contact with themselves. Similarly, although Type 303 or 303 Se have not been tested against Type 304 or 316, it is expected that this combination would resist galling better than Type 304 or 316 in contact with themselves.

Information was received verbally from Armco on September 19, 1960, to the effect that at a given hardness, Type 416 stainless steel would have better galling resistance than 17-4 PH when run against Type 304.

# Gall Resistance of Metals...I

These data were compiled by P J Olmstead, chief engineer, Goulds Pumps, with the assistance of G L Cox of The International Nickel Co.

Courtesy Goulds Pumps, Seneca Falls, NY

The chart shows the probable galling characteristics of various combination of materials. Either material of a combination may be the stationary or rotating part with no change in the galling characteristics.

The gall resistance of materials is characterized by the following criteria, and the gall resistance increases in the order named:

1. Hardness—such as nitrided or carburized steels.
2. Hardness plus inherent resistance to seizing by formation of silicides, as in "S" Monel, "S" nickel, "S" Inconel, or the like.
3. Inherent resistance to galling as in cast iron, ductile iron, Ni-Resist or "G" Nickel, due to lubricating qualities of graphitic carbon.

Where, and if, possible the following criteria should be used as a guide in selecting and machining materials for gall resistance:

1. Use austenitic against martensitic alloys.
2. Choose mating materials (except bronzes) with a difference in hardness of 50 Brinell numbers.
3. Grind mating surfaces.

Although a combination of materials may indicate non-galling characteristics, consider the possibility of galvanic corrosion arising from the combination of materials and the electrolyte or liquid present.

This chart was not prepared from an exhaustive study of each combination of metals, under all conditions of galling. The data were first set down 10 years ago from experiences and occasional bits of information. During this period, the chart has proved helpful to people who knew nothing about the subject, and their choices from the chart were reasonably good ones. The current chart incorporates a number of revisions, based on further experience.

	Cast Iron	3% Ni-Cast Iron	Ni-Resist (Type 1, 2)	Ductile Iron	Ductile Ni-Resist	"S" Monel	"K" Monel <sup>(1)</sup>	"B" Monel	"H" Monel	Duranickel	"G" Nickel <sup>(2)</sup>	"S" Nickel <sup>(2)</sup>	Inconel	"S" Inconel <sup>(3)</sup>	400 Stainless (Soft)	400 Stainless (Hard)	300 Stainless Steel	SAE 1000 to 6000 (Soft)	SAE 1000 to 6000 (Hard)	Bronze (Leaded) <sup>(5)</sup>	Ni-Vee Bronze "A" <sup>(4)</sup>	Ni-Vee Bronze "B"	Ni-Vee Bronze "D"	Ni-Al Bronze <sup>(6)</sup>	Hastelloy "A"—"B"	Hastelloy "C"	Hastelloy "D"	Nitrided Steel	Chrome Plate <sup>(7)</sup>	Stellite
400 Series Stainless Steel (Soft)	S	S	S	S	S	F	F	N	N	N	F	F	N	F	N	F	F	N	F	S	F	S	S	F	N	F	S	F	F	S
400 Series Stainless Steel (Hard)	S	S	S	S	S	F	F	F	F	F	S	S	F	S	F	S	F	S	S	S	S	S	S	F	F	S	S	S	S	S
300 Series Stainless Steel	S	S	S	S	S	F	N	N	N	N	F	F	N	F	F	F	N	N	F	S	F	S	S	F	N	F	S	S	S	S

Degree of Resistance: S — Satisfactory; F — Fair; N — Little or None  
Notes 1 to 7 — See pages .

### 10.1.3 Information on Wear Tests in Water

Tables 1, 2, and 3 are taken from the "Corrosion and Wear Handbook" pages 122, 123, and 124. Tests reported in the tables were conducted in water. Information on test conditions, and interpretation of wear factors are given in following notes:

#### FOREWORD TO TABLE 7-3—WEAR TEST DATA

##### *Test Conditions*

Wear factors were determined by means of two different wear test units. One unit, referred to as the piston-cylinder test rig, produces wear by means of linear reciprocating motion. The other unit, referred to as the journal-sleeve test rig, produces wear by means of rotational movement. The majority of the tests were conducted in oxygenated water containing 10 to 30 cc of oxygen (STP) per kilogram of water. The hydrogen content for wear tests in hydrogenated water varied from 200 to 500 cc (STP) per kilogram of water. For both environments initial electrical resistivity of the water was 500,000 ohm-cm or greater. Tests were normally run for 500,000 cycles. Details of the test procedures are given in chapter 5 on testing procedures.

##### *Interpretation of Wear Factors*

Wear factors for both tests were determined by measuring the weight loss per pound load per million cycles.

Most of the material combinations considered suitable for service application possessed a wear factor less than 100 mg per pound load per million cycles.

##### *Special Notes*

- (1) The martensitic stainless steels were tested in the hardened condition. For the precipitation-hardening alloys the symbol PH designates the hardened condition, and SA indicates the solution annealed condition. Ceramics, cermets, and various miscellaneous materials were tested in the as-received condition. The remaining metals and alloys were tested in the solution annealed condition. All references to chromium plating are to plating applied by an approved supplier. (See ch. 13.)
- (2) The surface finish of untested samples ranged from 8 to 16 microinch (rms).
- (3) The bearing combinations are arranged so that the entry in the "materials" column is the moving element of the wear couple unless otherwise indicated. The combinations are listed in order of increasing wear. A complete cross index of all couples can be found in the general index.

Table 1  
WEAR TEST DATA

Material*	Versus	Type of Test		Additives		Temp. °F	Load (psi)	Wear Factor ϕ
		Piston & Cylinder	Journal & Shaft	Lead (ppm)	Graphite (ppm)			
AISI 304 SS or 347 SS	RT-SI Ag Brazing Alloy ***		x		x	500	10	92
**	Chromium, As Plated (.0005")	x			x	500	8	150
**	Stellite No. 6	x			x	500	8	170
	Haynes 25 (Cold Worked)	x			x	500	8	210
	Haynes No. 21 (SA)	x			x	500	8	240
	Lead	x			x	200	8	270
	S-Monel	x			x	500	8	400
	USS 18-8 W (FH)	x			x	500	8	10 <sup>4</sup> 0
	Lead		x		x	500	10	2750
	AISI 304SS	x			x	500	8	3200
	17-4 FH (SA)	x			x	500	8	10 <sup>5</sup>
	S-Monel		x		x	500	10	reined
	BT Ag Brazing Alloy ***		x		x	500	10	4
	RT-SI Ag Brazing Alloy ***		x		x	500	10	4
	Lead		x		x	500	10	4
AISI 410 SS	Stellite No. 3	x			x	500	8	16
	Stellite No. 3		x		x	500	10	140
	Stellite No. 6		x		x	500	10	145
	AISI 410 SS		x		x	200	10	290
	AISI 410 SS		x		x	500	10	380
	AISI 410 SS		x	x		500	10	145
**	Graphitar 14 (1)							

\* Entry in this column is moving element of the wear couple  
unless otherwise indicated.

\*\* Employed in service  
(1) No valid wear factor; however, this combination was  
successfully utilized.

ϕ Wear Factor - Milligrams per  
pound load per million cycles  
\*\*\* Handy & Harman

Table 2

WEAR TEST DATA

Materials*	Versus	Type of Test		Additives		Temp. °F	Load (psi)	Wear Factor $\frac{\mu}{l}$
		Piston & Cylinder	Journal & Sleeve	Hydro-gen	Oxy-gen			
AISI 416 SS	AISI 416 SS	x			x	500	8	165
	AISI 416 SS		x	x		500	10	49
AISI 420 SS	AISI 420 SS	x			x	500	8	130
	AISI 420 SS		x		x	500	10	185
AISI 440C SS	Honed Chromium Plate (0.005") on Armco 17-4 PH		x		x	500	10	10
	AISI 440C SS	x			x	500	8	15
	AISI 440C SS		x		x	500	10	79
	AISI 440C SS		x		x	200	10	80
	AISI 440C SS		x	x		500	10	3
Armco 17-4 PH (SA)	Stellite No. 3	x			x	500	8	190
**	Honed Chromium Plate (0.005") on Armco 17-4 PH	x			x	500	8	195
	Armco 17-4 PH (PH)	x			x	500	8	440
	Armco 17-4 PH (SA)	x			x	500	8	10 <sup>6</sup>
Armco 17-4 PH (PH)	Honed Chromium Plate (0.005") on Armco 17-4 PH		x		x	500	10	4
**	Chromium, As Plated (0.005")		x		x	500	10	60
**	Honed Chromium Plate on Armco 17-4 PH (0.005")	x			x	500	8	35
**	Stellite No. 3		x		x	200	10	47
	Chrome Carbide in Ni matrix	x			x	500	8	72
**	Stellite No. 3	x			x	500	8	150

\* Entry in this column is moving element of the wear couple unless otherwise indicated.

$\frac{\mu}{l}$  Wear Factor - Milligrams per pound load per million cycles.

\*\* Employed in service.

Table 3

WEAR TEST DATA

Materials*	Versus	Type of Test		Additives		Temp. °F	Load (psi)	Wear Factor
		Piston & Cylinder	Journal & Shaft	Hydro- gen	Oxy- gen			
Armco 17-4 PH (PH) **	Chromium, Nitrided	x			x	500	8	160
**	Stellite No. 3		x		x	500	8	200
	Titanium, Nitrided	x			x	500	8	210
	Wall Colmonoy No. 6		x		x	500	10	220
**	Stellite No. 6		x		x	500	10	320
	Stellite No. 21 (SA)	x			x	500	8	340
	S-Ponel	x			x	500	8	430
	Armco 17-4 PH (PH)	x			x	500	8	460
	Haynes 25 (Cold Worked)	x			x	500	8	470
	AISI 304 SS	x			x	500	8	475
**	Stellite No. 3	x			x	200	8	2
**	Honed Chromium Plate (0.005") on Armco 17-4 PH	x			x	500	8	11
	Stellite No. 21 (PH)	x			x	500	8	25
**	Stellite No. 3	x			x	500	8	25
**	Stellite No. 6		x		x		10	100
	Wall Colmonoy No. 6		x		x	500	8	236

\* Entry in this column is moving element of the wear couple unless otherwise indicated.

† Wear Factor - Milligrams per pound load per million cycles.

\*\* Employed in service.

DIMENSIONS FOR SEAMLESS AND WELDED PIPE COMMONLY USED FOR CORROSION SERVICE †

Nominal Pipe Size	SCHEDULE 5S		SCHEDULE 10S		SCHEDULE 10		SCHEDULE 20		SCHEDULE 30		SCHEDULE 40S AND STANDARD WT. (B)		SCHEDULE 40(B)		SCHEDULE 60		
	Outside Diameter	Wall Thick.	Inside Diam.	Wall Thick.	Inside Diam.	Wall Thick.	Inside Diam.	Wall Thick.	Inside Diam.	Wall Thick.	Inside Diam.	Wall Thick.	Inside Diam.	Wall Thick.	Inside Diam.	Wall Thick.	Inside Diam.
1/8	.405	...	.307	...	...	...	...	...	...	...	...	...	...	...	...	...	...
1/4	.540	...	.410	...	...	...	...	...	...	...	...	...	...	...	...	...	...
3/8	.675	...	.545	...	...	...	...	...	...	...	...	...	...	...	...	...	...
1/2	.840	.065	.710	.083	.575	.083	.440	.083	.305	.165	.083	.269	.088	.088	.091	.091	.091
3/4	1.050	.085	.920	.083	.785	.083	.650	.083	.515	.113	.113	.384	.113	.113	.113	.113	.113
1	1.315	.109	1.185	.109	1.050	.109	.915	.109	.780	.133	.133	.493	.133	.133	.133	.133	.133
1 1/4	1.650	.085	1.530	.109	1.410	.109	1.290	.109	1.170	.140	.140	.622	.140	.140	.140	.140	.140
1 1/2	1.900	.085	1.770	.109	1.650	.109	1.530	.109	1.410	.145	.145	.622	.145	.145	.145	.145	.145
2	2.375	.085	2.245	.109	2.115	.109	1.985	.109	1.855	.154	.154	.622	.154	.154	.154	.154	.154
2 1/2	2.875	.083	2.709	.120	2.635	.120	2.560	.120	2.485	.203	.203	.622	.203	.203	.203	.203	.203
3	3.500	.083	3.334	.120	3.260	.120	3.185	.120	3.110	.216	.216	.622	.216	.216	.216	.216	.216
3 1/2	4.000	.083	3.834	.120	3.760	.120	3.685	.120	3.610	.226	.226	.622	.226	.226	.226	.226	.226
4	4.500	.083	4.334	.120	4.260	.120	4.185	.120	4.110	.237	.237	.622	.237	.237	.237	.237	.237
5	5.563	.109	5.345	.134	5.295	.134	5.245	.134	5.195	.258	.258	.622	.258	.258	.258	.258	.258
6	6.625	.109	6.407	.134	6.357	.134	6.307	.134	6.257	.280	.280	.622	.280	.280	.280	.280	.280
8	8.625	.109	8.407	.148	8.329	.148	8.251	.148	8.173	.322	.322	.622	.322	.322	.322	.322	.322
10	10.750	.154	10.432	.165	10.420	.165	10.250	.165	10.250	.365	.365	.622	.365	.365	.365	.365	.365
12	12.750	.154	12.438	.180	12.360	.180	12.250	.180	12.250	.375	.375	.622	.375	.375	.375	.375	.375
14	14.000	.156(A)	13.688	.188(A)	13.624	.188(A)	13.376	.188(A)	13.376	.375(1)	.375(1)	.622	.375(1)	.375(1)	.375(1)	.375(1)	.375(1)
16	16.000	.165(A)	15.670	.188(A)	15.624	.188(A)	15.376	.188(A)	15.376	.375	.375	.622	.375	.375	.375	.375	.375
18	18.000	.165(A)	17.670	.188(A)	17.624	.188(A)	17.376	.188(A)	17.376	.375	.375	.622	.375	.375	.375	.375	.375
20	20.000	.188(A)	19.624	.218(A)	19.564	.218(A)	19.250	.218(A)	19.250	.375	.375	.622	.375	.375	.375	.375	.375
24	24.000	.218(A)	23.564	.250(A)	23.500	.250(A)	23.250	.250(A)	23.250	.375	.375	.622	.375	.375	.375	.375	.375

Nominal Pipe Size	SCHEDULE 80S AND EXTRA STRONG (C)		SCHEDULE 80(C)		SCHEDULE 100		SCHEDULE 120		SCHEDULE 140		SCHEDULE 160		DOUBLE X STRONG		
	Outside Diameter	Wall Thick.	Inside Diam.	Wall Thick.	Inside Diam.	Wall Thick.	Inside Diam.	Wall Thick.	Inside Diam.	Wall Thick.	Inside Diam.	Wall Thick.	Inside Diam.	Wall Thick.	Inside Diam.
1/4	.405	.095	.215	.095	.215	.095	...	...	...	...	...	...	...	...	...
1/4	.540	.119	.302	.119	.302	.119	...	...	...	...	...	...	...	...	...
3/8	.675	.126	.423	.126	.423	.126	...	...	...	...	...	...	...	...	...
1/2	.840	.147	.546	.147	.545	.147	...	...	...	...	...	...	...	...	...
3/4	1.050	.154	.742	.154	.742	.154	...	...	...	...	...	...	...	...	...
1	1.315	.179	.957	.179	.957	.179	...	...	...	...	...	...	...	...	...
1 1/4	1.650	.191	1.278	.191	1.278	.191	...	...	...	...	...	...	...	...	...
1 1/2	1.900	.200	1.560	.200	1.500	.200	...	...	...	...	...	...	...	...	...
2	2.375	.218	1.939	.218	1.939	.218	...	...	...	...	...	...	...	...	...
2 1/2	2.875	.216	2.323	.216	2.323	.216	...	...	...	...	...	...	...	...	...
3	3.500	.300	2.900	.300	2.900	.300	...	...	...	...	...	...	...	...	...
3 1/2	4.000	.318	3.364	.318	3.364	.318	...	...	...	...	...	...	...	...	...
4	4.500	.337	3.825	.337	3.825	.337	...	...	...	...	...	...	...	...	...
5	5.563	.375	4.813	.375	4.813	.375	...	...	...	...	...	...	...	...	...
6	6.625	.432	5.761	.432	5.761	.432	...	...	...	...	...	...	...	...	...
8	8.625	.500	7.625	.500	7.625	.500	...	...	...	...	...	...	...	...	...
10	10.750	.500	9.750	.500	9.750	.500	...	...	...	...	...	...	...	...	...
12	12.750	.500	11.750	.500	11.750	.500	...	...	...	...	...	...	...	...	...
14	14.000	.500(2)	13.000	.500	13.000	.500	...	...	...	...	...	...	...	...	...
16	16.000	.500(2)	15.000	.500	15.000	.500	...	...	...	...	...	...	...	...	...
18	18.000	.500(2)	17.000	.500	17.000	.500	...	...	...	...	...	...	...	...	...
20	20.000	.500(2)	19.000	.500	19.000	.500	...	...	...	...	...	...	...	...	...
24	24.000	.500(2)	23.000	.500	23.000	.500	...	...	...	...	...	...	...	...	...

All dimensions are in inches.  
 Dimensions for Standard Weight, Extra Strong, Double Extra Strong, Schedule 80, 100, 120, 140 and 160 are in conformance with A.S.A. 836.10.  
 Dimensions for Schedules 5S, 10S, 40S, and 80S are in conformance with A.S.A. 836.19.  
 (A) Proposed wall thicknesses for Schedules 5S and 10S.  
 (B) Wall thicknesses for Schedules 40S and 80S are identical through 10" size.  
 (C) Wall thicknesses for Schedules 80S, 100S, and 120S are identical through 3" size.  
 (1) Thickness agrees with Weight Pipe A.S.A. 836.10; not included in Schedule 40S.  
 (2) Thickness agrees with that for Extra Strong Pipe (A.S.A. 836.10); not included in Schedule 80S.

† This table was taken from "Dimensions for Seamless and Welded Pipe Commonly Used for Corrosion Service", issued by Flowline Corp., New Castle, Pa.