

AD _____

Award Number: DAMD17-98-1-8302

TITLE: Compact Gamma Camera System for Breast Cancer Imaging

PRINCIPAL INVESTIGATOR: Stephen E. Derenzo, Ph.D.

CONTRACTING ORGANIZATION: University of California at Berkeley
Berkeley, California 94720

REPORT DATE: July 2001

TYPE OF REPORT: Final

PREPARED FOR: U.S. Army Medical Research and Materiel Command
Fort Detrick, Maryland 21702-5012

DISTRIBUTION STATEMENT: Approved for Public Release;
Distribution Unlimited

The views, opinions and/or findings contained in this report are those of the author(s) and should not be construed as an official Department of the Army position, policy or decision unless so designated by other documentation.

20020118 153

REPORT DOCUMENTATION PAGE

Form Approved
OMB No. 074-0188

Public reporting burden for this collection of information is estimated to average 1 hour per response, including the time for reviewing instructions, searching existing data sources, gathering and maintaining the data needed, and completing and reviewing this collection of information. Send comments regarding this burden estimate or any other aspect of this collection of information, including suggestions for reducing this burden to Washington Headquarters Services, Directorate for Information Operations and Reports, 1215 Jefferson Davis Highway, Suite 1204, Arlington, VA 22202-4302, and to the Office of Management and Budget, Paperwork Reduction Project (0704-0188), Washington, DC 20503

| | | | | |
|--|--|---|--|------------------------|
| 1. AGENCY USE ONLY (Leave blank) | | 2. REPORT DATE July 2001 | 3. REPORT TYPE AND DATES COVERED Final (1 Jul 98 - 30 Jun 01) | |
| 4. TITLE AND SUBTITLE Compact Gamma Camera System for Breast Cancer Imaging | | | 5. FUNDING NUMBERS DAMD17-98-1-8302 | |
| 6. AUTHOR(S) Stephen E. Derenzo, Ph.D. | | | | |
| 7. PERFORMING ORGANIZATION NAME(S) AND ADDRESS(ES) University of California at Berkeley Berkeley, California 94720 E-Mail: sederenzo@lbl.gov | | | 8. PERFORMING ORGANIZATION REPORT NUMBER | |
| 9. SPONSORING / MONITORING AGENCY NAME(S) AND ADDRESS(ES) U.S. Army Medical Research and Materiel Command Fort Detrick, Maryland 21702-5012 | | | 10. SPONSORING / MONITORING AGENCY REPORT NUMBER | |
| 11. SUPPLEMENTARY NOTES Report contains color | | | | |
| 12a. DISTRIBUTION / AVAILABILITY STATEMENT Approved for Public Release; Distribution Unlimited | | | | 12b. DISTRIBUTION CODE |
| 13. Abstract (Maximum 200 Words) (<i>abstract should contain no proprietary or confidential information</i>) <p>In this project we have developed a compact solid-state gamma camera specifically designed to image metabolically active tumors in the breast and axillary nodes with the highest possible detection efficiency and spatial resolution.</p> <p>We have assembled final versions of all major components of the proposed compact solid-state gamma camera: collimators, CsI(Tl) scintillator arrays, special low-noise silicon photodiode arrays, and custom integrated circuit readout chips. A prototype 64-pixel detector module was successfully assembled and images of point sources were acquired with this 64 pixel camera.</p> <p>Based on results to date, it appears that our compact camera design will yield very similar performance to traditional SPECT cameras. However, for the application of breast and axillary node imaging, our compact design will have the advantages of: (1) more potential imaging angles, (2) shorter imaging distances and hence higher image quality, and (3) lower cost, making the camera more readily available. Once completed, the new camera may help make scintimammography widely available as a valuable complement to traditional breast cancer screening and diagnostic techniques.</p> | | | | |
| 14. Subject Terms (keywords previously assigned to proposal abstract or terms which apply to this award) Breast Cancer | | | 15. NUMBER OF PAGES 22 | 16. PRICE CODE |
| 17. SECURITY CLASSIFICATION OF REPORT Unclassified | 18. SECURITY CLASSIFICATION OF THIS PAGE Unclassified | 19. SECURITY CLASSIFICATION OF ABSTRACT Unclassified | 20. LIMITATION OF ABSTRACT Unlimited | |

4. TABLE OF CONTENTS

| | |
|--------------------------------------|----|
| 1. Cover..... | 1 |
| 2. SF 298 | 2 |
| 3. Foreword | 3 |
| 4. Table of Contents | 4 |
| 5. Introduction..... | 5 |
| 6. Body..... | 5 |
| 7. Key Research Accomplishments..... | 8 |
| 8. Reportable Outcomes..... | 8 |
| 9. Conclusions | 9 |
| 10. References | 9 |
| 11. Appendices | 10 |

5. INTRODUCTION

The goal of this project is the development of a compact solid-state gamma camera specifically designed to image metabolically active tumors in the breast and axillary nodes with the highest possible detection efficiency and spatial resolution. The compact design (1) allows for a larger number of oblique views, (2) provides shorter imaging distances which results in improved spatial resolution and (3) reduces cost, which will make the instrument more widely available to the medical community. See Appendix 1, Figure 1 for a sketch of the imaging system, consisting of patient, camera, and readout electronics. See Appendix 1, Figure 2 for a sketch of the camera, consisting of the collimator, a 4 x 4 array of 64-pixel detector modules, the motherboard on which they are mounted, and the cable to the computer interface.

6. BODY OF THE PROGRESS REPORT

Tasks proposed for months 1-12:

- Purchase CsI(Tl) arrays and collimators (months 1-6)
- Fabricate silicon photodiode arrays (months 1-18)
- Fabricate custom integrated circuits containing charge amplifiers and WTA circuits (months 1-18)
- Assemble camera (collimator, crystal arrays, diode arrays, integrated circuit readout, flex strip output connections (months 9-24)

Tasks proposed for months 12-24:

- Fabricate custom integrated circuits containing charge amplifiers and WTA crystal identifier circuits (months 1-18)
- Assemble camera (collimator, crystal arrays, diode arrays, integrated circuit readout, flex strip output connections) (months 9-24)
- Interface camera to computer (months 18-24)
- Test system using calibration pulses and small ^{57}Co sources (months 20-24)

Tasks proposed for months 24-30:

- Measure intrinsic spatial resolution with and without scatter (months 24-30)
- Measure pulse height resolution with and without scatter (months 24-30)
- Measure planar sensitivity and count rate performance (months 28-36)
- Acquire images of isotope distributions using standard plastic phantoms (months 28-36)

Collimators

Based on our computer simulations [1], we have identified and acquired three collimator designs that will work well for breast cancer imaging. All have parallel hexagonal channels with lead septa and cover an area $10 \times 10 \text{ cm}^2$ (more than sufficient to cover a plane of $16 \times 24 \times 24 \text{ mm}^2$ detector modules). All designs have 1.5 mm diameter holes and a septal thickness of 0.25 mm but vary in length:

23.5 mm (all purpose), 16.5 mm (high sensitivity), and 13.0 mm (ultra high sensitivity).

CsI(Tl) Crystal Arrays

Two CsI(Tl) $12 \times 20 \text{ cm}^2$ crystal arrays with a depth of 5 mm and optically-isolated $3.0 \times 3.0 \text{ mm}^2$ pixels were acquired. These were cut into 32 smaller 8×8 pixel arrays consisting of 64 pixels each. The average dimensions on these smaller arrays is $24.2 \times 24.2 \text{ mm}^2$.

Silicon Photodiode Arrays

We have successfully fabricated, diced, tested, and passivated 64-pixel (8×8 element) silicon PIN photodiode arrays (Appendix 1, Figure 3) [2]. These arrays are larger versions of the 12-pixel (3×4 element) arrays we had previously developed [3]. The new arrays maintain the same $3.0 \times 3.0 \text{ mm}^2$ pixel size and per-pixel capacitance of about 2 pF.

The 34 arrays diced from the 5 most promising silicon wafers provided a total of 2176 pixels with a 98.5% yield of "good" pixels (good being defined as $<100 \text{ pA}$ leakage current at room temperature and 50 V bias). These 2143 good pixels demonstrate an extremely low leakage current of $28 \pm 7 \text{ pA}$ (average \pm standard deviation) at room temperature and 50 V bias, about an order of magnitude better than the best 64-pixel arrays that are commercially available. These data are summarized in the histogram presented in Figure 1. We now have in our possession about 25 arrays whose performance makes them excellent candidates for the final 16-module camera.

Photodiode quantum efficiency at the 540 nm emission wavelength of CsI(Tl) is approximately 80%.

Custom Integrated Circuit Readout Chip

We developed a custom integrated circuit chip containing 64 low-noise charge amplifiers and pulse shapers, a 64-channel winner-take-all (WTA) crystal identifier circuit, address electronics, and computer control of both the shaping time and gain of the 64 individual amplifiers [4]. Based on testing and experimentation with this version of the chip, we had refined the design of both the low-noise charge amplifiers/pulse shapers and the WTA crystal identifier. This culminated in two new 16-channel prototype ICs (one for the amplifiers and one for the WTA) which were then thoroughly tested and debugged.

Based on those results, we have completed our design of the final version of the 64-channel custom readout IC. This IC incorporates both an improved array of 64 charge amplifiers/pulse shapers and an improved 64-input WTA circuit. (See Appendix 1, Figure 4.) The IC has been successfully fabricated, diced from its wafers, had its backside coated with gold, and been wirebonded to our custom IC test boards. The IC meets performance expectations as follows: (1) power consumption is nominal, (2) rise and fall times can be externally adjusted, (3) the gain of each pre-amplifier can be externally adjusted, (4) the photodiode dark current compensation in each pre-amplifier can be externally adjusted, (5) qualitatively electronic noise looks acceptable, (6) the WTA circuitry correctly outputs the analog signal with the greatest amplitude, (7) the WTA circuitry produces the correct digital address for the channel with the largest analog signal, (8) the operational mode and noise-suppression threshold of the WTA can be externally controlled, and (9) the IC only responds to commands containing the

correct identifier sequence (thus allowing multiple ICs on the same bus to be controlled separately). (See Appendix 1, Figure 5.)

Detector Module

See Appendix 1, Figure 6 for a photograph of a complete detector module, consisting of an 8 x 8 array of 3 mm x 3 mm CsI(Tl) crystals 5 mm deep, the low-noise silicon photodiode array, the ceramic mounting board, and the custom integrated circuit readout chip, and the emf shield. Appendix 1, Figure 7 shows the individual components.

The multilayer ceramic circuit boards host the custom IC readout and control lines and as well as bypass capacitors, a metal cover to protect and EM shield the IC, and connectors for plugging an individual module into the motherboard.

The steps that must be performed to complete an individual detector module are as follows:

- 1 The custom readout IC is mounted onto the ceramic board.
- 2 Wirebonds are made between the ceramic board and the IC.
- 3 A printed circuit board is glued to the ceramic board.
- 4 Wirebonds are made from the IC pads to bonding pads on the printed circuit board.
- 5 The photodiode array is attached to the ceramic using conductive epoxy for electrical connection.
- 6 Underfill is applied between the photodiode array and the ceramic board to minimize the stress on the conductive epoxy bond.
- 7 The CsI(Tl) scintillator array is attached to the photodiode array using optically-transparent epoxy.

Steps (1) to (4) are out-sourced to an assembly company. We have been doing steps (5) to (7) in our lab. Step (5) require precision alignment and careful dispensing of the conductive epoxy. We are in the process of evaluating out-sourcing steps (5) to (6) to another assembly company.

Motherboard

See Appendix 1, Figure 8 for a photograph of the printed circuit motherboard on which a 4 x 4 array of detector modules can be mounted. This motherboard also contains resistor networks, peak detect hardware, and electronically-adjustable potentiometers. Appendix 1 Figure 9 shows the readout timing and peak detect circuitry and Appendix 1, Figure 10 shows the overall readout architecture. Appendix 1, Figure 11 shows the motherboard timing diagram.

The motherboard employs a custom winner-take-all (WTA) IC to identify the module which has the largest analog output in any given event. The peak of the signal is found using a peak detect circuitry and subsequently sent to an ADC on the data acquisition card. The motherboard also enables the correct output address bits that identify the pixel that generated the "winner" signal.

We have fabricated 4 motherboards for the gamma camera. Each is capable of imaging with a maximum of 16 individual 64-pixel imaging modules resulting in a 1024-pixel camera covering an area of 9.6 cm x 9.6 cm.

Imaging Tests

The software for the data acquisition and calibration of the camera have been implemented and we have successfully demonstrated the camera's capability and performance using a single imaging module excited with a 122 keV ^{57}Co point source (2.7 mm in diameter). See Appendix 1, Figure 12 for pulse height spectra from individual crystals, and Appendix 1, Figure 13 for the first images of a point source. The average energy resolution of the imaging module is about 17.4% fwhm for 140 keV gammas.

7. KEY RESEARCH ACCOMPLISHMENTS

- Arrays of 64 low-noise silicon photodiodes were fabricated with a yield per photodiode of 99% and an average leakage current in good elements of only 22 pA.
- We have developed a functional 64-input custom integrated readout circuit chip.
- Monte Carlo simulation software was developed and used to optimize the final camera design. High sensitivity hexagonal hole collimators and $3.0 \times 3.0 \text{ mm}^2$ silicon photodiode/CsI(Tl) scintillator pixels were shown to be wise design choices, while cooling of the electronics in order to lower noise proves unnecessary.
- Five high purity silicon wafers were fabricated and diced to produce 34 64-pixel photodiode arrays with a 98.5% yield of good pixels.
- Fabrication of the custom 64-channel integrated circuit readout chip was completed and testing shows that all functions are operational.
- Assembly procedures for the detector modules were developed, including gluing custom circuit boards together, mounting and wirebonding the integrated circuit, mounting the photodiode array, protecting the photodiode array with underfill epoxy, making additional wirebonds between the circuit boards and the photodiode array, and optically bonding the CsI(Tl) scintillator array to the photodiode array.
- Three printed circuit boards were designed and fabricated: (1) a test board for the custom integrated circuit (IC), (2) a ceramic board for mounting the photodiode array and hosting the IC fan in, and (3) a multilayer board for routing the IC output and control lines.
- We have completed construction of a compact gamma camera, consisting of 64 CsI(Tl) crystals, an array of 64 low-noise silicon photodiodes, and our custom readout integrated circuit. The first image of a point source was taken.

8. REPORTABLE OUTCOMES

G. J. Gruber, W. W. Moses, S. E. Derenzo, et al., "A discrete scintillation camera using silicon photodiode readout of CsI(Tl) crystals," *IEEE Trans. Nucl. Sci.*, vol. NS-45, pp. 1063-1068, 1998.

N.W. Wang, G. Conti, S.E. Holland, N.P. Palaio, G.J. Gruber, and W.W. Moses, "Improved photosensitive contact for back-illuminated silicon photodiode arrays," presented at the 1998 IEEE Nuclear Science Symposium and submitted to *IEEE Trans. Nucl. Sci.*

S. E. Holland, N. W. Wang, and W. W. Moses, "Development of low noise, back-side illuminated silicon photodiode arrays," *IEEE Trans. Nucl. Sci.*, vol. NS-44, pp. 443-447, 1997.

Gruber GJ, Moses WW and Derenzo SE. Monte Carlo simulation of breast tumor imaging properties with compact, discrete gamma cameras. *IEEE Trans. Nucl. Sci.* 1999; NS-46:2119-2123.

G. J. Gruber, W. S. Choong, W. W. Moses, S. E. Derenzo, S. E. Holland, M. Pedrali-Noy, B. Krieger, E. Mandelli, G. Meddeler and N. W. Wang, "A compact 64-pixel CsI(Tl)/Si PIN photodiode imaging module with IC readout," *IEEE Trans. Nucl. Sci.*, (submitted for publication), 2001.

Pedrali-Noy M, Gruber GJ, Krieger B, Mandelli E, Meddeler G, Moses WW and Rosso V. PETRIC—A Positron Emission Tomography Readout IC. *IEEE Trans. Nucl. Sci.* 2001 (in press).

Moses W, Pedrali-Noy M and Beuville E. Custom integrated circuit for multi-channel solid-state detector readout. LBNL Invention Disclosure Report No. IB-1472P, 2000. (DOE funded).

9. CONCLUSIONS

We have developed or purchased final versions of all major components of the proposed compact solid-state gamma camera: collimators, CsI(Tl) scintillator arrays, special low-noise silicon photodiode arrays, and custom integrated circuit readout chips. Monte Carlo simulations have helped optimize the final camera design, supporting the use of high-sensitivity hexagonal hole collimators and $3.0 \times 3.0 \text{ mm}^2$ pixels while demonstrating that cooling the electronics is not necessary [1].

A complete single module gamma camera was fabricated and an initial image was taken. The energy resolution of 17.4% fwhm for 140 keV gamma rays can be improved because we measured 10.7 % fwhm using a preliminary 3×4 array.

Based on results to date, it appears that our compact camera design will yield very similar performance to traditional SPECT cameras. However, for the application of breast and axillary node imaging, our compact design will have the advantages of: (1) more potential imaging angles, (2) shorter imaging distances and hence higher image quality, and (3) lower cost, making the camera more readily available. Once completed, the new camera may help make scintimammography a valuable complement to traditional breast cancer screening and diagnostic techniques.

10. REFERENCES

- [1] G. J. Gruber, W. W. Moses and S. E. Derenzo, "Monte Carlo simulation of breast tumor imaging properties with compact, discrete gamma cameras," *IEEE Trans. Nucl. Sci.*, vol. NS-46, pp. 2119-2123, 1999.
- [2] S. E. Holland, N. W. Wang and W. W. Moses, "Development of low noise, back-side illuminated silicon photodiode arrays," *IEEE Trans. Nucl. Sci.*, vol. NS-44, pp. 443-447, 1997.

- [3] G. J. Gruber, W. W. Moses, S. E. Derenzo, et al., "A discrete scintillation camera using silicon photodiode readout of CsI(Tl) crystals for breast cancer imaging," *IEEE Trans. Nucl. Sci.*, vol. NS-45, pp. 1063–1068, 1998.
- [4] M. Pedrali-Noy, G. J. Gruber, B. Krieger, et al., "PETRIC - a positron emission tomography readout IC," *IEEE Trans. Nucl. Sci.*, vol. NS-48, pp. (in press), 2001.

11. APPENDICES

Appendix 1: Figures referenced in the body of the text

Appendix 2: Preprint of G. J. Gruber, W. S. Choong, W. W. Moses, S. E. Derenzo, S. E. Holland, M. Pedrali-Noy, B. Krieger, E. Mandelli, G. Meddeler and N. W. Wang, "A compact 64-pixel CsI(Tl)/Si PIN photodiode imaging module with IC readout," *IEEE Trans. Nucl. Sci.*, (submitted for publication), 2001.

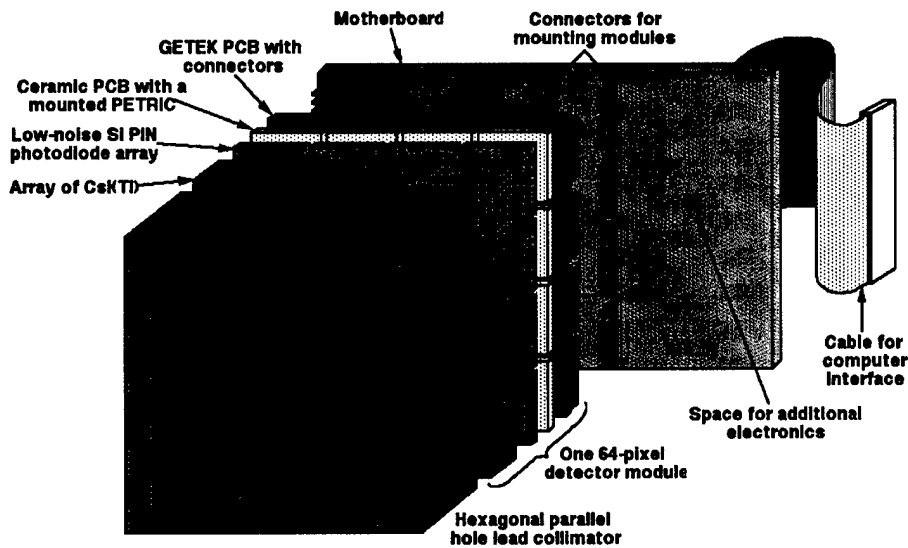
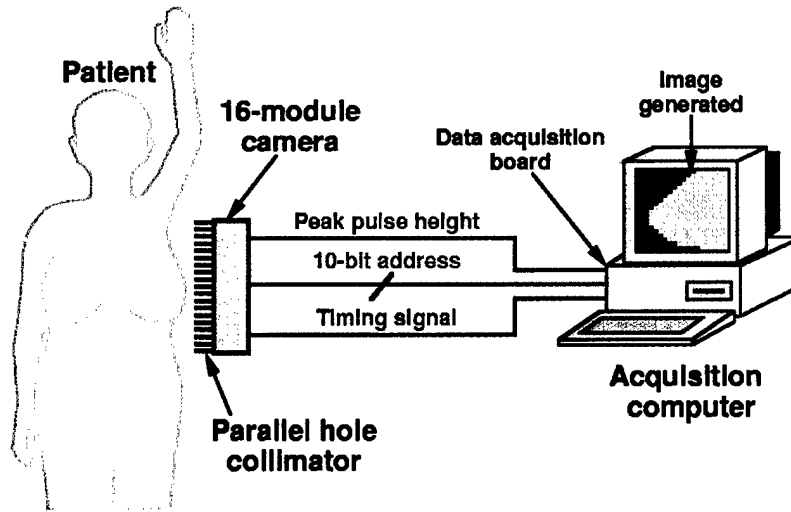

A scintammography imaging camera constructed from tiling 16 individual 64-pixel modules

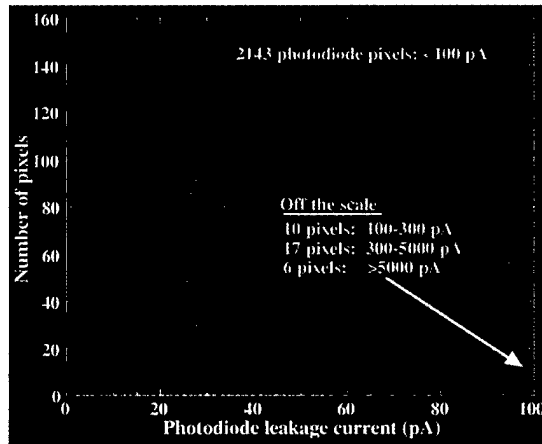
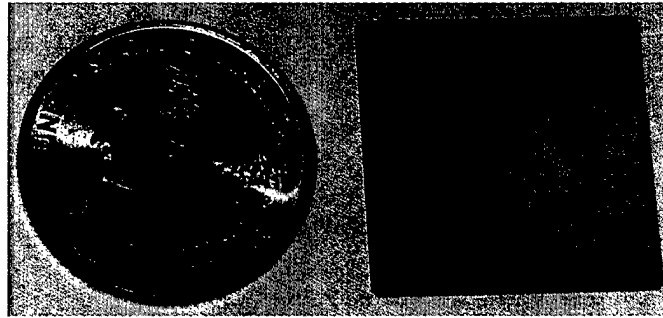

- low leakage current (<50 pA/pixel @ 50 V)
- 3 pF/pixel capacitance
- 80% quantum efficiency for 540 nm light
- 98.5% good pixel yield during fabrication

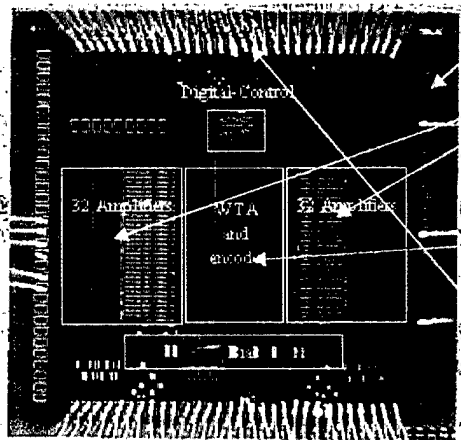

- Input: 64 photodiode signals plus control signals that modify ASIC behavior
- Front end: 64 channels of low-noise charge-sensitive preamplifiers and adjustable shaper amplifiers
- "Winner Take All" (WTA): reduces the 64 amplified, shaped signals to a single "winner" channel (the one with the greatest amplitude)
- Output: the 1 analog "winner" plus 6 digital bits identifying the winning pixel

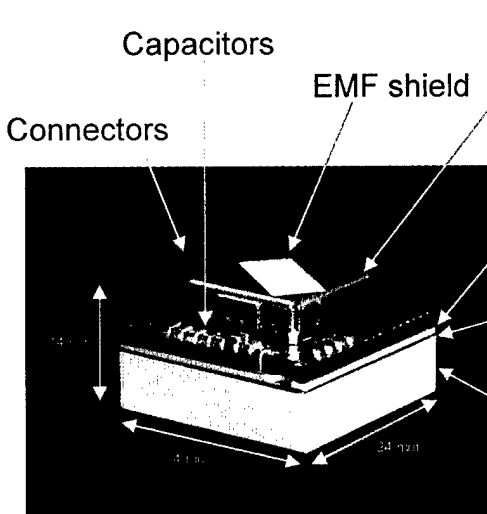
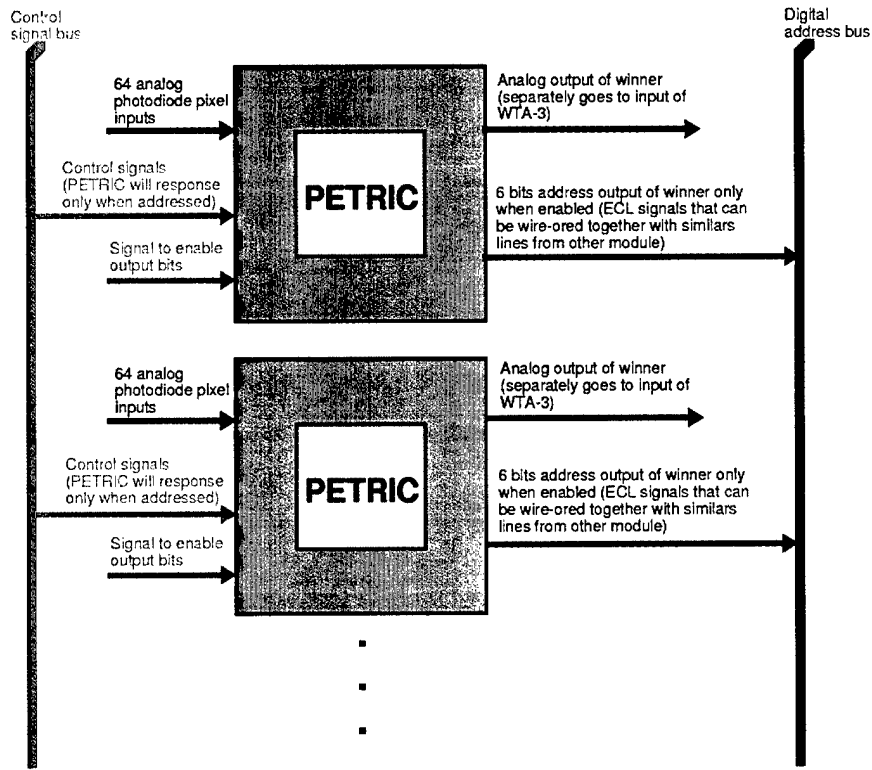

- PETRIC readout: 64 front end channels followed by "Winner Take All" circuitry that selects the channel with the greatest amplitude, very compact
- Custom printed circuit boards: provide electrical connections to the photodiodes and the PETRIC
- Custom Si PIN photodiodes: very low leakage current (<50 pA/pixel) => low electronic noise
- CsI(Tl) crystals: commercial 3 x 3 x 5 mm³ crystal array

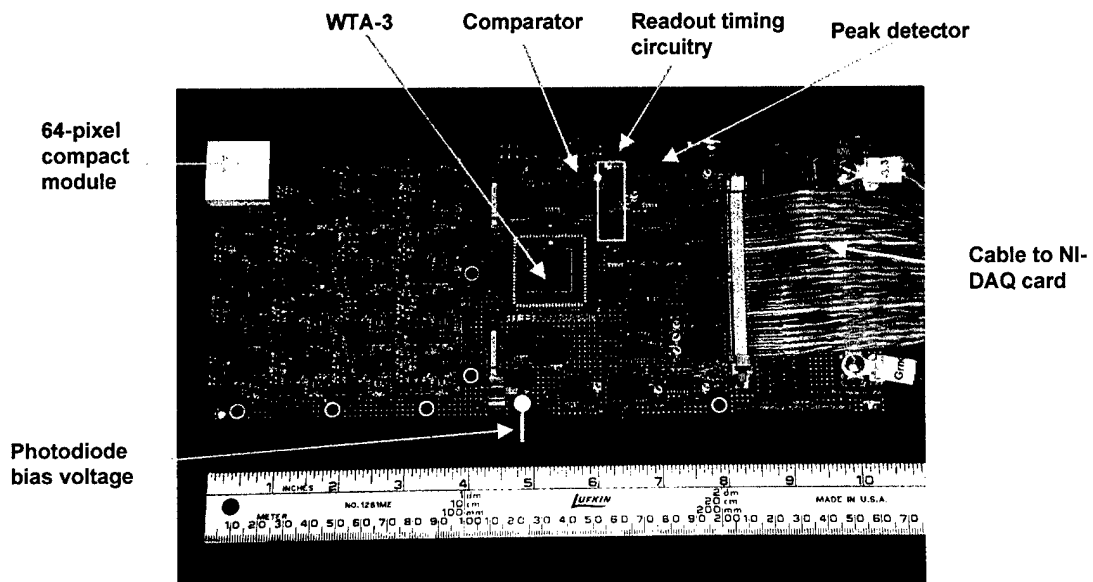
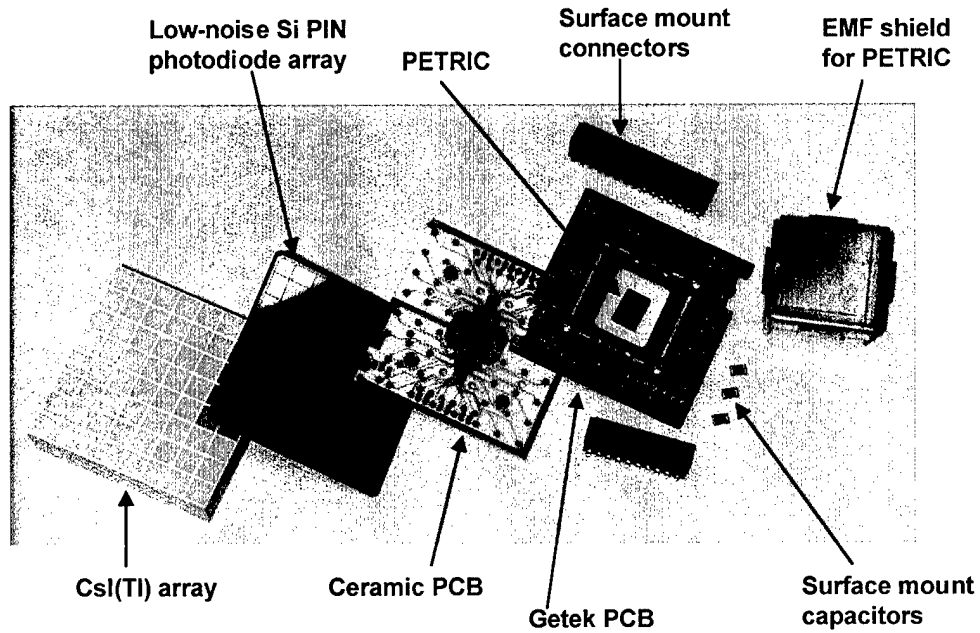

- Most major blocks of the board have been verified and debugged
- Data acquisition software under development

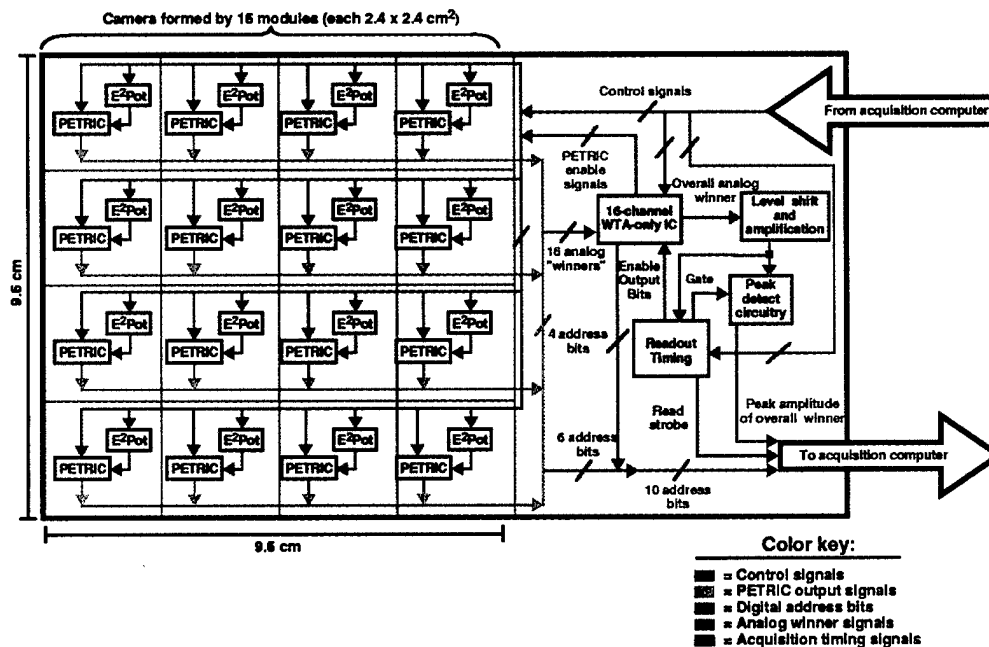
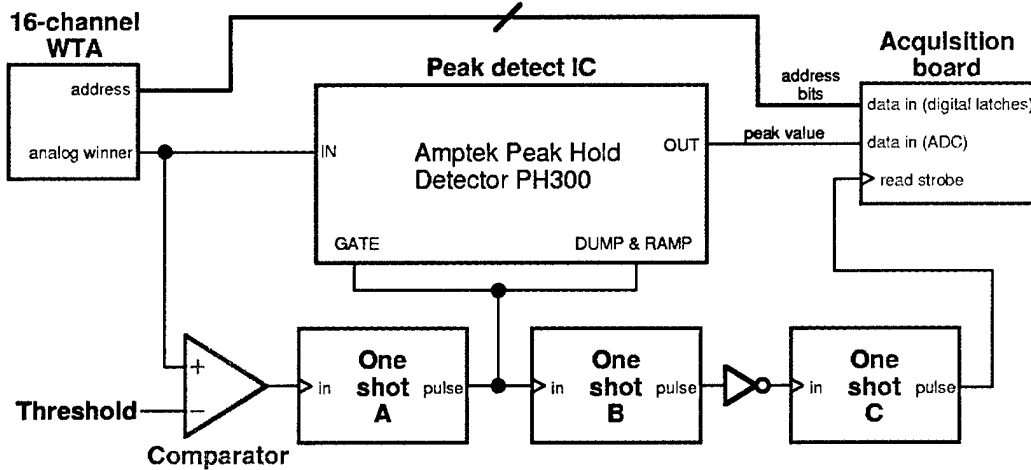



- Taken with a 5 mm diameter, 100 μ Ci Co57 source placed behind a lead sheet with a 2.7 mm hole in it
- Used a high sensitivity collimator (16,200 c/mCi/s, 8.0 FWHM at 6 cm)
- Imaged at an imaging distance of 5 cm for 10 minutes

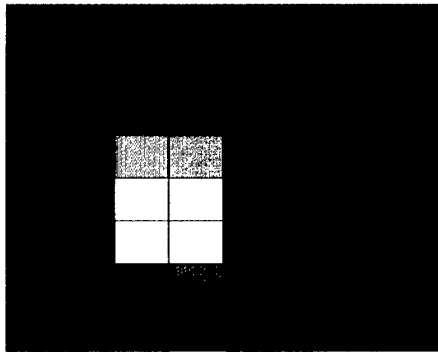

- Imaged in air
- 7.6 mm FWHM
- Max Count/Min Count ~ 1100

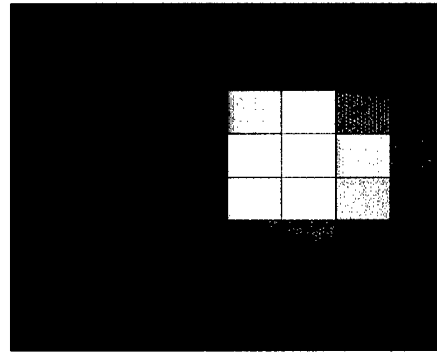

- Imaged with water as scattering medium
- 7.8 mm FWHM
- Max Count/Min Count ~ 550

A Compact 64-Pixel CsI(Tl)/Si PIN Photodiode Imaging Module with IC Readout

G. J. Gruber, W. S. Choong, *Member, IEEE*, W. W. Moses, *Senior Member, IEEE*, S. E. Derenzo, *Senior Member, IEEE*, S. E. Holland, *Member, IEEE*, M. Pedrali-Noy, *Member, IEEE*, B. Krieger, *Member, IEEE*, E. Mandelli, *Member, IEEE*, G. Meddeler, *Member, IEEE*, and N. W. Wang.

Abstract—We present a complete 64-pixel compact gamma camera imaging module consisting of optically isolated $3\text{ mm} \times 3\text{ mm} \times 5\text{ mm}$ CsI(Tl) crystals coupled to a custom array of low-noise Si PIN photodiodes read out by a custom IC. At 50 V bias the custom 64-pixel photodiode arrays demonstrate an average leakage current of 28 pA per $3\text{ mm} \times 3\text{ mm}$ pixel, a 98.5% yield of pixels with <100 pA leakage, and a quantum efficiency of about 80% for 540 nm CsI(Tl) scintillation photons. The custom 64-channel readout IC uses low-noise preamplifiers, shaper amplifiers, and a winner-take-all (WTA) multiplexer. The IC demonstrates maximum gain of $120\text{ mV} / 1000\text{ e}^-$, the ability to select the largest input signal in less than 150 ns, and low electronic noise at 8 μs peaking time ranging from 25 e^- rms (unloaded) to an estimated 180 e^- rms (photodiode load of 3 pF, 50 pA). A complete 64-pixel detector using the final photodiode arrays and prototype ICs yields an average room temperature energy resolution of 17% fwhm for the 122 keV emissions of ^{57}Co . Construction of an array of such imaging modules is straightforward, hence this technology shows strong potential for numerous compact gamma camera applications, including scintimammography.

I. INTRODUCTION

THE need for small, compact gamma cameras that can provide close proximity, high quality single photon imaging of small organs has been emphasized in recent years by the problem of breast cancer. For the 180,000 new breast cancer cases and 44,000 related deaths in the U.S. each year [1], [2] conventional Anger cameras have proven suboptimal in imaging tumors, in part because their large and bulky size prevents close access to desired imaging sites. The result is decreased sensitivity, a problem which could be lessened by compact camera design. Other small organ imaging applications, as well as applications involving surgical probes or the imaging of small animals, would also potentially benefit from compact gamma cameras.

The most common approach to designing a compact gamma camera is to replace the bulky photomultiplier tubes (PMTs) with much more compact devices, either solid-state photodetectors [3]–[6] or solid-state radiation detectors such as CdZnTe which replace the scintillator in addition to the PMTs [7]–[8]. The major technological challenge in implementing these designs is to achieve a system that

matches Anger camera performance, particularly with regard to energy resolution, reliability, and cost. Silicon photodiodes have traditionally suffered from excessive electronic noise, HgI₂ photodiodes typically experience reliability problems, and CdZnTe remains an expensive material from which it is difficult to mass produce arrays of useful imaging size.

The solid-state detector (either photodiodes or CdZnTe) thus requires innovative development to achieve the material properties necessary to successfully eliminate the PMTs. Further, the electronics readout must be made extremely dense to accommodate the large number of discrete pixels present in a reasonable imaging area. In this paper we present a 64-pixel compact imaging module consisting of discrete CsI(Tl) crystals coupled to low-noise Si PIN (p-layer, intrinsic layer, n-layer) photodiodes which are read out by a custom IC. This work scales up our previous prototype work [4] from 12 to 64 pixels and presents a complete modular design that can be used to realize a variety of compact gamma camera configurations.

II. MODULE COMPONENTS

The key components in the 64-pixel imaging module are presented in Fig. 1 along with their approximate sizes. The design revolves around making the module as compact as possible in order to optimize it for applications (such as scintimammography) which benefit from reduced imaging distances, a greater variety of views, and unique configuration possibilities such as using multiple cameras simultaneously.

The two critical innovations that make this camera technology feasible are the low-noise Si PIN photodiodes [9] and the custom IC readout [10]. The former replaces the bulky and expensive PMTs used in traditional Anger cameras, while the latter provides extremely dense processing of 64 pixel signals per $4.5\text{ mm} \times 4.8\text{ mm}$ IC. Since energy resolution is a prime concern, the electronic noise generated by both devices must be minimized. This is challenging because IC readout is typically noisy in comparison to discrete component readout, while photodiodes are obviously noisy compared to PMTs. The low-noise photodiodes employed in these modules are the first reliable devices with sufficiently low room temperature leakage current to provide adequate energy resolution for the applications under consideration.

Manuscript received November 5, 2000. This work was supported in part by the U.S. Department of Energy under contract No. DE-AC03-76SF00098, in part by Public Health Service Grants Nos. P01-HL25840 and R01-CA67911, in part by the Fannie and John Hertz Foundation, and in part by the University of California at Berkeley.

The authors are with the Lawrence Berkeley National Laboratory, Berkeley, CA 94720 USA (telephone: 510-486-6757, e-mail: wschoong@lbl.gov).

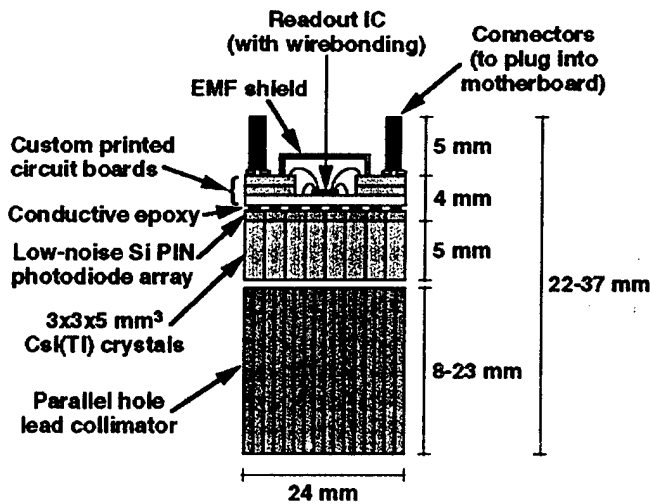

Fig. 1. Key components in a complete 64-pixel CsI(Tl) scintillator/Si PIN photodiode imaging module with custom IC readout. The total depth of the module depends on the collimator design but is less than 4 cm. A compact gamma camera constructed from an array of such modules need have a depth only slightly greater than that of the individual modules.

The remainder of the components include custom printed circuit boards that are carefully designed to interface the photodiode signals with the readout IC and a number of commercially available items. The latter include a high sensitivity hexagonal hole lead collimator, an array of optically isolated 3 mm × 3 mm × 5 mm CsI(Tl) crystals, connectors, and shielding for the IC.

A. Silicon PIN Photodiode Arrays

A 64-pixel Si PIN photodiode array with 3 mm × 3 mm elements is pictured in Fig. 2. A series of four guard rings run around the perimeter of the array to sink surface leakage current. The array is designed to maintain a 3 mm pitch between pixels when butted up against other arrays, so edge and corner pixels are slightly smaller than central pixels. The corners of the arrays are cropped slightly in order to allow space for small wires to carry the 50 V bias around the edge of the array to the backside.

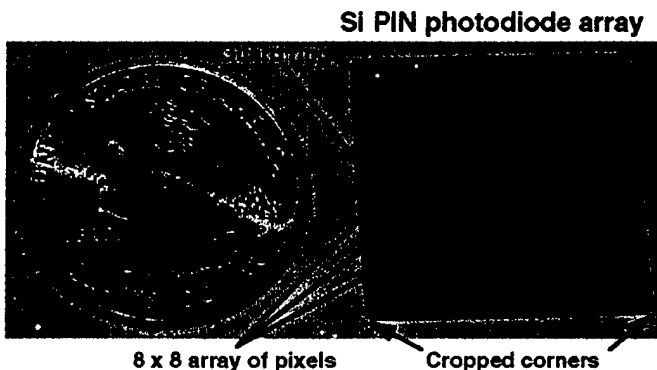

Fig. 2. Low-noise Si PIN photodiode array consisting of 64 3 mm × 3 mm pixels, with a quarter (2.4 cm diameter) for scale. The side shown in the patterned n-layer, while the backside is the unpatterned, light-sensitive n-layer. A series of 4 guard rings encircle the array of pixels.

The goal in implementing the 64-pixel arrays was simply to replicate the 12-pixel prototype photodiode performance from [10] on a larger scale. This is challenging in part because if the yield for individual pixels is y , then the yield

for perfect 12-pixel arrays is y^{12} while that for 64-pixel arrays is much smaller at y^{64} . Since the pixel yield, y , for the 12-pixel prototype arrays is only about 80%, this presents a major problem. In order to increase the yield a new process for depositing and annealing the phosphorus-doped polysilicon was developed: instead of deposition at 650° C and no annealing, deposition was performed at 500° C and followed by annealing at 600° C. This increases the photodiode yield, y , to greater than 98% and thus the array yield, y^{64} , to at least 27%. The leakage current of the photodiodes is not noticeably affected, but as an added performance bonus the resistivity of the polysilicon is reduced by almost an order of magnitude.

Fig. 3 presents a histogram of the leakage currents of the pixels in 34 arrays. The devices were in darkness at room temperature under 50 V bias. The “good” pixels (those with less than 100 pA leakage current) demonstrate an average current of 28 ± 7 pA, about an order of magnitude better than the best commercial Si photodiode arrays presently available. The guard rings of all 34 arrays exhibit an average current of 1.7 ± 0.4 nA. Using the 100 pA metric, the yield for individual photodiode elements is 2143 of 2176, or 98.5%. This provides a respectable y^{64} of 38%, which is consistent with the observed yield of 41% (14 of 34) flawless arrays. Further, if one “bad” (i.e., high leakage current) pixel per array is acceptable, then the array yield increases to 74% (25 of 34).

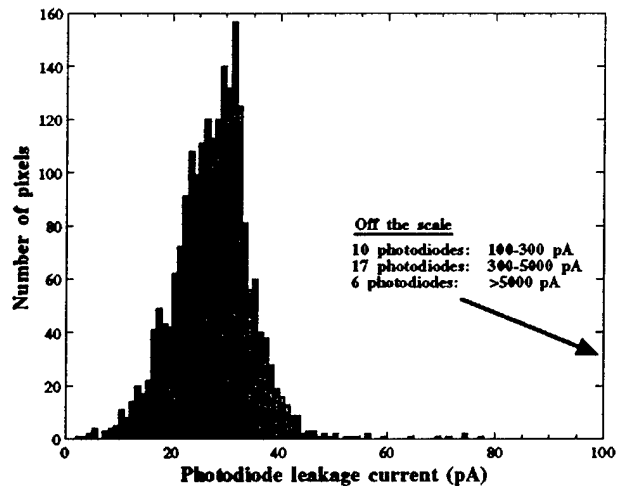

Fig. 3. Histogram of the leakage current values for photodiodes in 34 64-pixel arrays. Histogram bins are 1 pA wide. Photodiodes are 3 mm × 3 mm in size and were in the dark at room temperature under a 50 V bias. The pixels with leakage current less than 100 pA (2143 out of 2176) demonstrate an average current of 28 ± 7 pA.

The photodiodes are optimized for the 540 nm scintillation photons of CsI(Tl) with a 67.9 nm thick anti-reflective layer of indium-tin-oxide (ITO), yielding a quantum efficiency of about 80%. Finally, the photodiodes demonstrate the expected capacitance of about 3 pF per pixel.

B. Custom IC Readout of Photodiodes

The readout IC is described in detail in [10]. It is a mixed analog-digital design fabricated in CMOS 0.5 μ m 3.3 V technology and covering an area of 4.5 mm × 4.8 mm. Its front end is an array of 64 analog input channels consisting of charge-sensitive preamplifiers and shaper amplifiers, the behavior of which can be adjusted with external signals. The

noise performance of the front end has been carefully studied and optimized, and at 8 μ s peaking time (approximately optimal for CsI(Tl) scintillation), the performance ranges from 25 e^- rms when unloaded to an estimated 180 e^- rms with a photodiode load (3 pF, 50 pA). The IC provides a maximum gain of 120mV / 1000 e^- . Prototype versions of the front end are described in [11].

The remainder of the IC is dominated by the "Winner Take All" (WTA) circuitry. This section reduces the 64 amplified, shaped signals to a single "winner" channel by constantly selecting the channel with the greatest amplitude. The end result is that 64 analog input lines are reduced to a single analog output line plus 6 digital bits which identify the location of the winning channel. The IC is able to select the largest input signal and generate the corresponding 6-bit address in less than 150 ns. Careful layout of the WTA circuitry is crucial since feedback of digital noise into the sensitive preamplifiers could result in chip failure. Prototype versions of the WTA circuitry are described in [12].

III. DESIGN CHOICES

A number of key design decisions were made in the course of developing the 64-pixel imaging modules. These choices are targeted at producing modules that are viable as the building blocks for compact gamma cameras useful for scintimammography and other applications. To that end, tradeoffs were selected that provide good performance while producing devices that can be constructed and assembled into a modular array in a straightforward and reasonably inexpensive fashion.

A. Compactness and Dead Area

The major advantages of this technology revolve around providing compactness, so this needs to be exploited to the fullest. As is evidenced in Fig. 1, the majority of the module depth is taken up by the collimator and the CsI(Tl), which cannot be made significantly smaller. The electronics readout—including the custom printed circuit boards, the IC, and the connectors for plugging into a motherboard—are less than 1 cm in depth, much of which is the connectors.

By maintaining virtually no camera dead area, the number of useful clinical views this technology can provide is increased. No module components extend beyond the active area of the 64-pixel array, so multiple modules can be butted up against each other with little or no dead area in between or at the edges of the camera. Dead area at the camera periphery, then, will be determined solely by the thickness of the packaging and lead shielding. Note that the photodiodes (Fig. 2) are designed to provide 3 mm pitch between all pixels, even those on different arrays. The slightly smaller edge and corner pixels employed to achieve this do decrease signals levels in those pixels, but since the corresponding CsI(Tl) crystals are still full size there is no introduction of imaging dead area.

B. Pixel Size

Monte Carlo simulations were conducted in [13] that suggest that decreasing pixel size much below 3 mm \times 3 mm offers little advantage in imaging breast tumors. This is not surprising given that collimator spatial resolution—not the intrinsic spatial resolution determined by pixel size—is typically the limiting factor in such medical

applications. Further, since the size of the tumors that can be successfully imaged with gamma cameras is generally significantly larger than 3 mm, small pixel size is not critical. Decreasing pixel size (and therefore the area of a 64-pixel module) does, however, significantly increase the density of the readout electronics, making it challenging to fit all the electronics within the same area as the pixel array. This increases complexity and expense (more modules are now required to cover the same area), and may result in less compact devices. Hence 3 mm \times 3 mm pixels were employed.

C. Cooling of Photodiodes

Matching the \sim 9% full-width at half-max (fwhm) energy resolution offered by conventional Anger cameras at 140 keV has historically been challenging with CsI(Tl)/Si photodiode technology. One potential means of improving energy resolution is to cool the photodiodes to about 5° C in order to lower leakage current and therefore electronic noise. While a room temperature energy resolution of 10.7% fwhm at 140 keV was observed in [4], a cooled environment lowered the figure to 7.5% fwhm at 122 keV for similar technology [5]. However, the Monte Carlo simulations in [13] suggest that small improvements in energy resolution do not significantly improve tumor imaging. Therefore the 64-pixel module described in this paper is designed to be operated at room temperature, avoiding the added complexity, size, and expense of a cooling system.

D. Collimation

Although any collimator could be attached in front of the detector module, the intent is to use a high sensitivity hexagonal hole lead collimator. Again, the simulations in [13] suggest that high sensitivity is more advantageous than high resolution and that hexagonal holes perform comparably to square holes. As new collimator technology advances, however, it may become preferable to use a square hole tungsten laminate collimator wherein the square holes are matched to the individual pixels. Matching more than one hole to each pixel (e.g., 4-to-1 or 9-to-1) offers the possibility of an extremely compact collimator.

IV. COMPLETE 64-PIXEL MODULES

A. Module Assembly

A complete 64-pixel module immediately prior to the final assembly steps is depicted in Fig. 4. Assembly of the components requires a careful series of steps during which multiple epoxies are applied, wirebond connections are made, and surface mount components are soldered into place. Key challenges during assembly revolve around the very sensitive photodiode array and readout IC, including avoiding physical damage to them, avoiding thermal damage to them, and providing them with all necessary wirebond and conductive epoxy electrical connections.

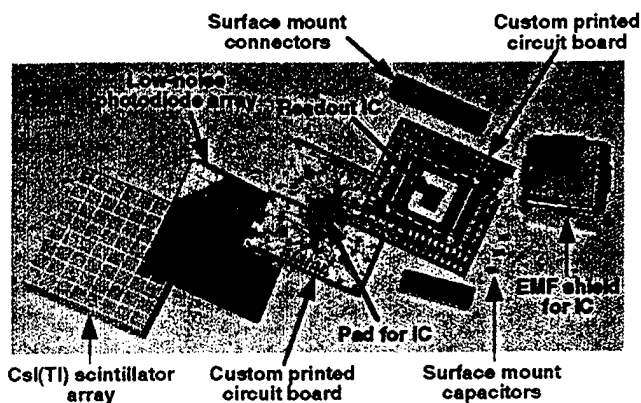

Fig. 4. Complete but unassembled 64-pixel module. The CsI(Tl) and low-noise photodiode array are coupled together with transparent epoxy. The photodiodes connect to the custom printed circuit boards via carefully applied drops of conductive epoxy. The readout IC is wirebonded to the printed circuit boards, which support the IC by routing input signals from the photodiodes, control signals from the connectors, and the output signals generated by the IC.

B. Energy Resolution

Typical room temperature pulse height spectra for channels excited by the 122 keV emissions of ^{57}Co are shown in Fig. 5. These results are typical of the 64-pixel modules, with energy resolutions ranging from 15 to 18% fwhm and averaging 17%. At 140 keV the expected energy resolution would therefore be 15%. While this figure is not as low as has been achieved with the smaller prototype detectors in [4] and [5], it does demonstrate that the technology has been successfully scaled up to 64 pixels while maintaining a reasonable energy resolution. The simulations from [13], for example, show little difference in breast tumor imaging qualities over a range of energy resolutions from 5 to 15% fwhm. Thus modular imaging devices of useful imaging size and good performance can be assembled from this technology.

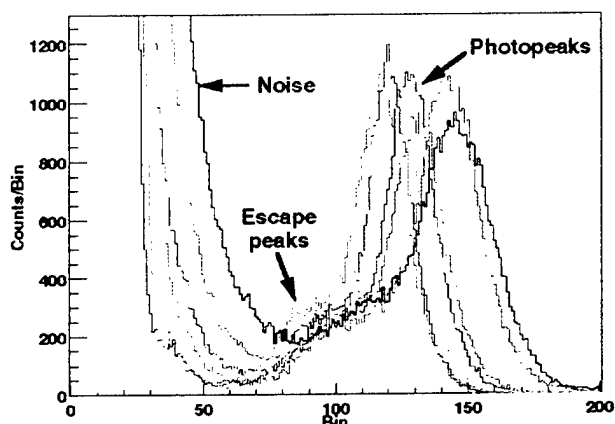

Fig. 5. Pulse height spectra for 9 pixels excited by 122 keV gammas from ^{57}Co . Energy resolution ranges from 15 to 18% fwhm, with an average of 17%. Results are typical for the 64-pixel module.

V. CONCLUSIONS

The key and innovative advances in the development of the 64-pixel compact imaging modules are (1) the IC which allows efficient readout of many channels and (2) the low leakage current Si PIN photodiodes which can replace traditional PMTs without introducing unacceptably high

electronic noise. Both devices behave to expectations and contribute to a highly compact imaging module that demonstrates good performance and has virtually no dead area.

In addition to the emphasis on compactness, the module has been designed so that an array of such devices can be assembled to form a complete compact gamma camera of useful imaging size. Future directions for this work obviously include constructing such a camera and characterizing its performance. This involves the design and fabrication of a motherboard which the individual modules are plugged in to and which interfaces with a data acquisition computer, a project already underway for a 4×4 16 module design. Finally, since the energy resolution of the complete 64-pixel modules is currently adequate but not at the minimum for this technology, some effort will be directed toward further improving it.

VI. ACKNOWLEDGMENT

We would like to thank Dr. T. F. Budinger for his advice during many discussions regarding this research. We further thank C. S. Tindall for the work he performed processing the photodiode arrays, M. H. Ho for his many contributions in the lab, and G. J. Zizka for his extensive wirebonding efforts.

This work was supported in part by the Director, Office of Science, Office of Biological and Environmental Research, Medical Science Division of the U.S. Department of Energy under Contract No. DE-AC03-76SF00098, in part by the Laboratory Technology Research Division SC-32, (formerly called ERLTT), Office of Science, US Department of Energy under a CRADA (Cooperative Research and Development Agreement) between Lawrence Berkeley National Laboratory and Capintec, Inc., Ramsey, NJ under US DOE Contract DE-AC03-76SF00098, and in part by the National Institutes of Health, National Cancer Institute under grant No. R01-CA67911, and National Institutes of Health, National Heart, Lung, and Blood Institute under grant No. P01-HL25840.

VII. REFERENCES

- [1] J.R. Harris, M. E. Lippman, U. Veronesi, and W. Willett, "Breast cancer," *New England Journal of Medicine*, vol. 327, pp. 319-28, 1992.
- [2] S. L. Parker, T. Tong, S. Bolden, and P. A. Wingo, "Cancer statistics, 1997," *A Cancer Journal for Clinicians*, vol. 47, pp. 319-28, 1997.
- [3] J. Strobel, N. H. Clinthorne, and W. L. Rogers, "Design studies for a cesium iodide silicon photodiode gamma camera," *Journal of Nuclear Medicine*, vol. 38, pp. 31P, 1997.
- [4] G. J. Gruber, W. W. Moses, S. E. Derenzo, N. W. Wang, E. Beuville, and M. H. Ho, "A discrete scintillation camera module using silicon photodiode readout of CsI(Tl) crystals for breast cancer imaging," *IEEE Transactions on Nuclear Science*, vol. 45, pp. 1063-1068, 1998.
- [5] B. E. Patt, J. S. Iwanczyk, C. Rossington Tull, N. W. Wang, M. P. Tornai, and E. J. Hoffman, "High resolution CsI(Tl)/Si-PIN detector development for breast imaging," *IEEE Transactions on Nuclear Science*, vol. 45, pp. 2126-2131, 1998.
- [6] M. P. Tornai, B. E. Patt, J. S. Iwanczyk, C. S. Levin, and E. J. Hoffman, "Discrete scintillator coupled mercuric iodide photodetector arrays for breast imaging," *IEEE Transactions on Nuclear Science*, vol. 44, pp. 1127-1133, 1997.
- [7] J. F. Butler, C. L. Lingren, S. J. Friesenhahn, F. P. Doty, W. L. Ashburn, R. L. Conwell, et al., "CdZnTe solid-state gamma camera," *IEEE Transactions on Nuclear Science*, vol. 45, pp. 1158-1165, 1998.
- [8] M. Singh and E. Mumcuoglu, "Design of a CZT based BreastSPECT system," *IEEE Transactions on Nuclear Science*, vol. 45, pp. 1158-1165, 1998.

- [9] S. E. Holland, N. W. Wang, and W. W. Moses, "Development of low noise, back-side illuminated silicon photodiode arrays," *IEEE Transactions on Nuclear Science*, vol. 44, pp. 443-447, 1997.
- [10] M. Pedrali-Noy, G. J. Gruber, B. Krieger, E. Mandelli, G. Meddeler, W. W. Moses, et al., "PETRIC—A Positron Emission Tomography Readout Integrated Circuit," submitted for publication to *IEEE Transactions on Nuclear Science*, 2000.
- [11] W. W. Moses, I. Kipnis, and M. H. Ho, "A 16-channel charge sensitive amplifier IC for a PIN photodiode array based PET detector module," *IEEE Transactions on Nuclear Science*, vol. 41, pp. 1469-1472, 1994.
- [12] W. W. Moses, E. Beuville, and M. H. Ho, "A Winner-Take-All IC for determining the crystal of interaction in PET detectors," *IEEE Transactions on Nuclear Science*, vol. 43, pp. 1615-1618, 1996.
- [13] G. J. Gruber, W. W. Moses, and S. E. Derenzo, "Monte Carlo simulation of breast tumor imaging properties with compact, discrete gamma cameras," *IEEE Transactions on Nuclear Science*, vol. 46, pp. 2119-2123.