

AD \_\_\_\_\_

Award Number: MIPR 8MBLERM8936

TITLE: In Vivo, Fiberoptic-Coupled Radiation Dose Verification System for Prostate Radiotherapy

PRINCIPAL INVESTIGATOR: Brian L. Justus, Ph.D.

CONTRACTING ORGANIZATION: Naval Research Laboratory  
Washington, DC 20375

REPORT DATE: April 2001

TYPE OF REPORT: Final

PREPARED FOR: U.S. Army Medical Research and Materiel Command  
Fort Detrick, Maryland 21702-5012

DISTRIBUTION STATEMENT: Approved for public release;  
Distribution unlimited

The views, opinions and/or findings contained in this report are those of the author(s) and should not be construed as an official Department of the Army position, policy or decision unless so designated by other documentation.

20020118 187

**REPORT DOCUMENTATION PAGE**Form Approved  
OMB No. 074-0188

Public reporting burden for this collection of information is estimated to average 1 hour per response, including the time for reviewing instructions, searching existing data sources, gathering and maintaining the data needed, and completing and reviewing this collection of information. Send comments regarding this burden estimate or any other aspect of this collection of information, including suggestions for reducing this burden to Washington Headquarters Services, Directorate for Information Operations and Reports, 1215 Jefferson Davis Highway, Suite 1204, Arlington, VA 22202-4302, and to the Office of Management and Budget, Paperwork Reduction Project (0704-0188), Washington, DC 20503

<b>1. AGENCY USE ONLY (Leave blank)</b>		<b>2. REPORT DATE</b> April, 2001	<b>3. REPORT TYPE AND DATES COVERED</b> Final (30 Sep 99 - 30 Mar 01)	
<b>4. TITLE AND SUBTITLE</b> In Vivo, Fiberoptic-Coupled Radiation Dose Verification System for Prostate Radiotherapy			<b>5. FUNDING NUMBERS</b> MIPR 8MBLERM8936	
<b>6. AUTHOR(S)</b> Brian L. Justus, Ph.D.				
<b>7. PERFORMING ORGANIZATION NAME(S) AND ADDRESS(ES)</b> Naval Research Laboratory Washington, DC 20375  E-MAIL: bjustus@nrl.navy.mil			<b>8. PERFORMING ORGANIZATION REPORT NUMBER</b>	
<b>9. SPONSORING / MONITORING AGENCY NAME(S) AND ADDRESS(ES)</b>  U.S. Army Medical Research and Materiel Command Fort Detrick, Maryland 21702-5012			<b>10. SPONSORING / MONITORING AGENCY REPORT NUMBER</b>	
<b>11. SUPPLEMENTARY NOTES</b>				
<b>12a. DISTRIBUTION / AVAILABILITY STATEMENT</b> Approved for public release; Distribution unlimited				<b>12b. DISTRIBUTION CODE</b>
<b>13. ABSTRACT (Maximum 200 Words)</b> A fiberoptic-coupled patient dose verification system has been successfully developed that provides real-time dose rate and total dose information during radiotherapy treatments. The system has up to seven channels that can simultaneously provide dosimetry data at seven locations inside the body, at and near the prostate. The spatial resolution of the dose measurements is less than a millimeter. The fiberoptic-coupled system utilizes novel, optically stimulated luminescence (OSL) glass fiber dosimeters that permit all-optical readout of the total dose and dose rate. The system has been characterized and its performance evaluated in side by side tests with conventional radiation sensors, such as ionization chambers, Si diodes and MOSFET dosimeters. These comparisons were conducted in phantoms and in clinical trials with patients. The characterization experiments included measurement of the dose response, the resistance to radiation damage, the energy dependence of the response, the angular dependence of the response and the dose rate dependence of the response. In every case the fiberoptic-coupled dosimeter provided the correct measurement, often with accuracy to within 1% of the accepted values. The fiberoptic-coupled OSL dosimeter will enhance the effectiveness of prostate radiotherapy procedures, reduce negative side effects such as death, incontinence and impotence, and improve the quality of life for prostate cancer survivors.				
<b>14. SUBJECT TERMS</b> prostate cancer                      fiberoptic sensing                      OSL in vivo dosimetry                      optically stimulated luminescence			<b>15. NUMBER OF PAGES</b> 45	
			<b>16. PRICE CODE</b>	
<b>17. SECURITY CLASSIFICATION OF REPORT</b> Unclassified	<b>18. SECURITY CLASSIFICATION OF THIS PAGE</b> Unclassified	<b>19. SECURITY CLASSIFICATION OF ABSTRACT</b> Unclassified	<b>20. LIMITATION OF ABSTRACT</b> Unlimited	

## Table of Contents

<b>Cover.....</b>	<b>1</b>
<b>SF 298.....</b>	<b>2</b>
<b>Table of Contents.....</b>	<b>3</b>
<b>Introduction.....</b>	<b>4</b>
<b>Body.....</b>	<b>5 - 17</b>
<b>Key Research Accomplishments.....</b>	<b>18</b>
<b>Reportable Outcomes.....</b>	<b>19</b>
<b>Conclusions.....</b>	<b>20 - 21</b>
<b>References.....</b>	<b>22 - 23</b>
<b>Figures.....</b>	<b>24 - 37</b>
<b>Bibliography.....</b>	<b>38 - 45</b>

## Introduction

A fiberoptic-coupled patient dose verification system has been successfully developed that can provide real-time dose rate and total dose information during radiotherapy treatment of the prostate. The system can have up to seven channels that can simultaneously provide dosimetry data at seven locations inside the body, at and near the prostate. The spatial resolution of the dose measurements is less than a millimeter. The fiberoptic-coupled system utilizes novel, optically stimulated luminescence (OSL) glass fiber dosimeters that permit all-optical readout of the total dose and dose rate. The system has been characterized and its performance evaluated in side by side tests with conventional radiation sensors, such as ionization chambers, Si diodes and MOSFET dosimeters. These comparisons were conducted first in phantoms under actual clinical conditions and then in patients receiving external beam therapy. The characterization experiments in phantoms included measurement of the dose response, the resistance to radiation damage, the energy dependence of the response, the angular dependence of the response and the dose rate dependence of the response. In every case the fiberoptic-coupled dosimeter provided the correct measurement, often with accuracy to within 1% of the accepted values. The clinical trials with patients showed good agreement between doses measured using the fiberoptic-coupled OSL dosimeter and doses that were measured using MOSFET and diode dosimeters. The fiberoptic-coupled OSL dosimeter will enhance the effectiveness of prostate radiotherapy procedures, reduce negative side effects such as death, incontinence and impotence, and improve the quality of life for prostate cancer survivors.

## Body

The stated technical objectives of the Phase I research program have been met. We proposed to develop a fiber-optic-coupled, remote sensing radiation dosimeter system to be used for internal *in-vivo* patient dose verification during radiotherapy and we proposed to evaluate the performance of the patient dose verification system in clinical trials, side-by-side with conventional dosimetry systems. A multichannel, fiber-optic coupled dosimetry system was successfully developed and evaluated in both phantom measurements and in clinical trials with a small number of patients. The primary purpose of the dosimetry system that was developed is to provide health care providers with the ability to monitor, in real-time, the radiation dose delivered to the diseased tissue as well as to surrounding tissues during radiotherapy treatments in order to improve the therapeutic outcome. No other dosimetry system, be it TLD, silicon diode or MOSFET, can provide such real-time, *in-vivo* information. It is helpful to briefly review the three dosimetry systems currently available for patient dose verification.

TLDs are superb integrating dosimeters. They are available in a wide variety of forms and sizes. Lithium Fluoride (LiF) has an effective atomic number of 8.2 and a density of  $2.64 \text{ g/cm}^3$  (1). The most popular form for radiotherapy applications is the 3.175 mm square by 0.9 mm thick extruded ribbon, although sizes as small as  $1 \text{ mm}^3$  are used for special applications. Their thinness makes them useful for surface dosimetry. They have been shown to be insensitive to changes in calibration to radiation type (electrons or photons), energy (within the megavoltage range), dose rate, radiation direction, or over time, provided suitable procedures are followed to eliminate shallow, unstable electron traps. The dose-response of LiF is also linear from 0.1 mGy to 10 Gy and the accuracy of dose information is within  $\pm 5\%$ . Finally, the individual detector cost is small and they have a long useful life (1,2).

Despite all of these advantages, there are several drawbacks to the use of LiF TLDs for *in-vivo* dosimetry that have led to the development of alternative methods. Primarily, the readout system is not coupled to the detector(s), requiring a separate, post-irradiation evaluation of the dosimeters. The result is that no real-time dose or dose-rate information is provided. This makes any dose dependent intra-treatment medical decision impossible. Additionally, the individual dosimeters must be evaluated sequentially, rather than in parallel, further extending the time between irradiation and the complete evaluation of dosimetric information. The detector readout process typically takes about 30 seconds per chip and the annealing process an additional 3 or more hours, which limits detector availability and results in the necessity of maintaining a rather large detector pool for frequent clinical use. Also, while the detectors themselves are inexpensive, the processing equipment, TLD reader, computer and annealing ovens are not. These items are also bulky, a factor which results in establishing a centralized TLD processing area, removed from the immediate treatment environment. In order to maximize accuracy, individual detector calibrations must be maintained, which results in intricate bookkeeping and handling

procedures. Finally, the detectors are subject to damage through mechanical handling procedures and their dose-response is very dependent upon the overall consistency of the readout and annealing procedure.

Silicon diodes were introduced in the early 1980's as a replacement for small ionization chambers as *in-vivo* dosimeters. They are the most popular dosimeters for routine clinical measurements. Constructed primarily from silicon, they have an effective atomic number close to 14 and a density on the order of  $2.4 \text{ g/cm}^3$ . Both p-type and n-type diode dosimeters have been marketed. Diodes produce an electrical current when irradiated. This current is collected and integrated to obtain a reading corresponding to absorbed dose. Typically these detectors are operated unbiased, as this minimizes leakage current, and adequate current is generated at normal dose-rates used for radiotherapy. Diodes used for *in-vivo* dosimetry have integral buildup material to provide an equilibrium or  $d_{\text{max}}$  response to the ambient radiation environment as well as to compensate for an over-response of the detector at low photon energies. Diodes have a significantly better sensitivity than an ionization chamber of corresponding size, a near isotropic radiation response and a linear dose-response. They have a minimum sensitivity of  $0.01 \text{ Gy/min}$  and an overall accuracy of  $\pm 3\text{-}5\%$  (3-5). One of the salient features of current diode dosimetry systems is the ability to monitor several sites simultaneously and to produce an alarm when a user specified threshold dose is exceeded by a specific detector.

The disadvantages of diodes are their size, with a diameter of 5-10 mm, which limits their use as internal dose monitors to a few intracavitary sites and their inherent shielding which, along with their size, precludes their use as surface or transition zone dosimeters. This factor limits the spatial accuracy of the dose determination, which is acceptable for most external dosimetry measurements, but not for internal dosimetry. Inherent shielding is necessary to compensate for an energy dependent dose-response. The use of inherent shielding requires the purchase of several sets of diodes, depending on the energies and types of radiation to be measured. Their response varies with ambient temperature and with dose per pulse, which is exhibited as a non-standard inverse-square dependence (6). They have a finite operational lifetime due to accumulated dose, which requires that they be replaced periodically when in clinical use. Sensitivity to R-F interference has also been reported (7).

Miniature MOSFET dosimeters are new to clinical radiation dosimetry. Their small size relative to diodes substantially improves spatial accuracy relative to diodes and is comparable to that of TLDs. MOSFETs for *in-vivo* dosimetry are mounted on a 20 cm long thin flat semi-opaque polyimide laminate substrate attached to a cable. The actual detector is a 2 mm square of p-type Si mounted on the substrate and encapsulated in a 1 mm thick layer of black epoxy. When irradiated, a threshold voltage shift is produced which, when subtracted from the pre-irradiation voltage shift, is proportional to the amount of radiation collected. As such, the MOSFET is an integrating dosimeter (8,9). Up to 4 detectors are permanently attached to a bias supply that, in turn, is connected to the amplifier/readout unit. The sensitivity of MOSFETs is similar to that of diodes. Unlike diodes, however, they can be used for surface dose measurements, as they lack inherent buildup. While there have been experiments with MOSFETs as internal,

typically intracavitary, dosimeters, the currently manufactured products are still too large to fit into commercial interstitial catheters (10).

There are several drawbacks to MOSFETs as dosimeters. First is their short operational lifetime and relatively frequent recalibration requirements (after as little as 70 Gy accumulated dose). The angular dependence of their dose response can vary up to 17% in the hemisphere posterior to the substrate strip. The dose-response of MOSFETs is non-linear at high doses. Their accuracy is less than that of diodes at low doses and their reproducibility is poor. Also, as integrating dosimeters, they do not provide real-time dose-rate information and cannot be used to provide either real-time site dose assessment or treatment control. The dosimeter tips are also fragile and require careful handling (11).

For this research project, the technical goals were limited to developing the hardware, software and the procedures to safely and effectively make real-time dosimetry measurements using a fiberoptic-coupled OSL glass. It should be emphasized that, while the ultimate payoff of this work is to provide healthcare providers with the ability to modify, on-line, the course of a radiotherapy treatment, such control was not within the scope of this research proposal. The clinical protocol approved first by the IRB at the National Cancer Institute and subsequently by the USAMRMC provided only for data collection under very specific circumstances. The IRB did not provide for changes in the medical treatment based on feedback received from the dosimeter system. However, in the future, when the feedback can be used to make medical decisions about the progress of the treatment, the proposed patient dose verification system is expected to enhance the effectiveness of prostate radiotherapy treatments by optimizing the targeting and delivery of the radiation dose. The research accomplishments within each specific task cited in the approved statement of work are discussed below.

**Task 1: Develop a patient dosimetry system using catheterized fiberoptic glass dosimeters and a laser readout unit suitable for clinical studies.**

- Manufacture glass fiber dosimeters and attach them to commercial fiberoptic cables.
- Adapt fiberoptic dosimeters for use with standard medical catheters.
- Design and manufacture a laser-based optical readout system.

In order to accomplish the goals set out in Task 1, a wide range of scientific and technical issues were addressed. First, the glass fiber dosimeters were fabricated and optimized. It is important to understand the physical processes that occur in the glass fiber dosimeters in order to fully appreciate why the optically stimulated luminescence (OSL) fiberoptic-coupled dosimeter system possesses so many advantages compared to other technologies. The properties of the OSL glass phosphors in many ways resemble those of traditional thermoluminescence dosimeter (TLD) materials. Ionizing radiation produces free

electrons in the glass that are subsequently trapped at defects, or trapping centers. The traps are metastable and the trapped electrons can persist for long periods of time. The metastable trapped charges in a TLD material can be released by bulk heating of the material. The released charges recombine with a luminescence center and a small fraction of the recombination events results in the emission of a photon. In the OSL glass phosphors the trapped charges can be released by illumination with light. The processes that occur in the OSL glass phosphor are illustrated in the energy level diagram of Figure 1. Heating is not required to release the trapped charges. This has obvious advantages if the goal is the use of the dosimeter for internal, *in vivo* dosimetry measurements. It simply is not practical or safe to heat a TLD phosphor to several hundred degrees celcius while it is inside a patient's body. There are many other advantages of the OSL glass phosphors. For example, in a TLD dosimeter the luminescence efficiency of the material changes (decreases) as the temperature is raised during readout. Since optical stimulation of the trap release occurs at room temperature, there is no change in the luminescence efficiency during readout. This provides OSL materials with a significantly enhanced overall sensitivity. A particular advantage of the OSL glass is the optical transparency of the glass to the OSL emission. Light generated within the volume of a transparent glass dosimeter has a greater probability of being detected, compared with opaque phosphors such as LiF, resulting in a significant increase in detection efficiency. Finally, the optically transparent OSL glass can be readily fused to a high quality fused silica optical fiber for remote signal monitoring. This is because the OSL glass, a metal-ion doped fused quartz, has essentially the same thermal properties as high quality fused silica. Therefore, the OSL glass fibers are readily fused to commercially available optical fibers using standard plasma fusion techniques.

Previous attempts by other research groups to develop practical OSL glass phosphors have been unsuccessful. The primary reason for this is the nature of the glass host and the difficulties with effectively doping the glass. OSL glasses developed by other groups have been characterized by shallow traps. Shallow traps result in significant fading, rapid saturation of the signal and limited dynamic range of the dosimeter (12,13). In addition, previously developed OSL glasses were made using lower melting glass formulations, such as borosilicate or aluminosilicate glass. Although dopants can be easily incorporated into such glasses it is not so trivial to activate the glasses so that they exhibit sensitive optically stimulated luminescence. The use of the plasma fusion technique for joining the OSL glass fiber to a commercial silica fiber is impossible with lower melting point glass. The novel doped fused quartz OSL glass phosphors developed by the Naval Research Laboratory overcome the problems mentioned above relating to shallow trap depth, excessive fading, early saturation, limited dynamic range and low melting point (14-18). The native defects in these glasses are fairly deep in terms of the energy of the trap. In addition, the high melting point of the fused quartz permits the use of high temperature diffusion

techniques to dope the metal ions into the glass and to activate the glass to become OSL active.

OSL glass fibers were fabricated starting with a fused quartz rod, 20 mm in diameter and 1 meter in length. This rod was doped with  $\text{Cu}^{+1}$  ions by thermal diffusion of the ions at temperatures in excess of  $1100^{\circ}\text{C}$ . The doped rod was then drawn into a 1 km length of OSL glass fiber having a core diameter of 400  $\mu\text{m}$ . Fiberoptic-coupled dosimeters were constructed by cutting 1 mm lengths of the OSL glass fiber and joining them to a 1 m long commercial multi-mode optical fiber by fusion splicing. Fusion splicing creates a substantially stronger bond than other joining methods and also eliminates a reflective boundary at the junction, resulting in improved light transmission efficiency. The tip of the fiber was coated with a thin layer of aluminum to reflect both the stimulation and the signal light. The fiber tip was then coated with black enamel paint to completely block external light. The resulting fiberoptic dosimeter is a light-tight, flexible, 0.60 mm diameter probe that can be easily inserted into a traditional medical catheter. The 1 m dosimeter fibers were generally used in conjunction with a 10 m long fiber patchcord. This permitted the readout unit to be placed up to 10 m away from the radiation source. The fiberoptic-coupled dosimeters provide unprecedented spatial resolution due to their extremely small size. The volume of the OSL fiber tip ( $\sim 1$  mm long, 0.4 mm diameter) is several times less than the volume of either Si diode or MOSFET electronic dosimeters. For the USAMRMC program a number of different types of OSL glass fibers were fabricated and investigated. The optimal OSL glass characteristics depended on how the dosimeter was to be used. As will be explained later, the fiberoptic-coupled dosimeter can be used in a scintillation mode as well as an optically stimulated mode. The trap characteristics of the OSL glass can be selected to optimize one, or the other, or both of these modes. This involves engineering the trap populations in the glass during the glass fabrication. For example, an OSL glass based on a Herasil 3 fused quartz doped with  $\text{Cu}^{+}$  ions, was found to have outstanding trap properties for optically stimulated luminescence. The characteristics of the commercial silica fibers that are used as patchcords are also important. Some fibers were found to have high background scintillation levels during irradiation, and were not used. The fibers that were selected for use had low scintillation levels and were also moderately radiation hard. This allows for a long lifetime of the fiberoptic-coupled dosimeter. We have found that the dosimeter fibers we have fabricated have an extremely long usable lifetime. We have conducted extensive tests of the fiber dosimeter under actual clinical conditions using a Clinac 20 and a Clinac 6 and found that the fiber properties were unchanged after radiation exposure of thousands of Gy. This is equivalent to the treatment of hundreds of patients. Competing technologies, such as Si diodes and MOSFETS have to be regularly recalibrated because their properties change with exposure to radiation. MOSFETs, for example, must be discarded after a cumulative dose of 200 Gy has been measured.

Several laser-based readout systems were designed, built and tested during the program. The purpose of the readout system is to remotely stimulate the OSL glass fiber to emit OSL light and then collect the OSL emission in order to determine the absorbed radiation dose. The first readout system monitored a single fiberoptic-coupled dosimeter. This readout system used discrete optical components to guide the laser light into the fiber and direct the stimulated signal light to a photomultiplier tube. The discrete optical components were mounted in mirror mounts and were aligned before each use. A schematic of the first readout unit is shown in Figure 2. The output of the photomultiplier tube was stored in a file on a personal computer. The data could not be displayed in real-time, it was accessed using a spreadsheet after the conclusion of the exposure. Computer control of the operation was absent because there was no interface between the readout unit and the computer.

The second readout unit was significantly more advanced than the first. In this design all of the discrete optical components were replaced with fiberoptics. A bifurcated fiber bundle was used to deliver the optical stimulation light to the dosimeter and collect the OSL light. The bundle was constructed using seven optical fibers arranged in a six-around-one configuration. One end of the bundle was divided into two legs, one leg consisting of six fibers for signal collection and a single fiber leg to deliver the stimulation light. The other end of the bundle was connected to the fiber dosimeter via a 10 meter long patch cord. A 1.2 Watt, 790 nm fiberoptic-coupled GaAlAs diode laser was used to stimulate the OSL signal. The OSL signal from the tip of the dosimeter probe was directed back through the fiber and into the fiber bundle assembly. Six of the seven fibers that make up the bundle were used to direct the signal light to a photon counting module. The intensity of the signal light measured with the PCM was proportional to the absorbed radiation dose. The use of the fiber bundle technology as opposed to using discrete optical elements such as lenses, mirrors and beamsplitters resulted in considerable cost savings. The dosimeter system was also much more rugged and could be transported to different locations without loss of optical alignment. The improved stability and simplicity resulted in an improvement in overall performance. A schematic of the dosimeter system based upon fiber bundle technology is shown in Figure 3.

In addition to the improved optical system, a sophisticated computer interface was developed using LabView programming. The LabView program is used to control all aspects of the dosimeter system. When the irradiation period begins, the scintillation signal rises sharply and is recorded for the duration of the exposure. When the irradiation period is completed, the scintillation signal drops below a preset threshold level and a programmed time delay of 2 to 5 seconds is invoked prior to the OSL readout. The laser is turned on and the OSL signal is recorded for a period of 2 seconds. The OSL and scintillation signals are integrated and processed using predetermined calibration factors. The results of the measurement are displayed on the screen and written to a spreadsheet file. After the data is collected, the laser is used to bleed the excess stored charge

down to a predetermined level to reset the dosimeter for the next measurement. The signal processing and resetting of the dosimeter takes approximately 10 seconds. The control panel provides several visual displays, including numerical displays of the dose rate, the accumulated dose and the average dose, bar charts with pre-selected dose thresholds that provide a warning if any one dosimeter exceeds a limit and a chart recorder output that displays the signal as a function of time.

**Task 2: Perform clinical studies using the dosimetry system completed in Task 1.**

- Study characteristics of the system using tissue equivalent phantoms.
- Perform dose verification on ~20 patients receiving prostate beam therapy treatments.
- Assess the utility of the system.

The performance of the single channel, fiberoptic-coupled dosimetry system was thoroughly characterized in both scintillation and OSL modes. When the fiber dosimeter is exposed to radiation a prompt luminescence, or scintillation, is observed. The intensity of this scintillation signal is proportional to the dose rate, or dose per unit time. If the dose per unit time is integrated over time, then the total dose, in principle, can be determined. Scintillation data was collected by acquiring data continuously throughout the exposure. While scintillation detection worked quite well in conjunction with our relatively low energy Faxitron x-ray machine, problems were encountered with the use of the scintillation mode with higher energy sources. At higher energy, Cerenkov radiation is induced in the optical fiber and represents a fairly significant background signal that interferes with the detection of the scintillation light. This problem was not unexpected. Other fiberoptic-coupled dosimeters have been developed in the past that use scintillation to measure the dose rate (19,20). These include the use of scintillating plastic fibers that have been glued to the tip of a glass or plastic optical fiber. Cerenkov radiation was observed in these studies as well. The standard method to attempt to account for Cerenkov radiation is the use of a reference fiber. The reference fiber is identical in every respect to the dosimeter fiber except that it does not have the short piece of dosimeter attached at the tip. Any scintillation light observed in this reference fiber when irradiated with x-rays is assumed to be due to the patchcord fiber only. It is then assumed that if the reference fiber signal is subtracted from the dosimeter fiber signal, then an accurate measure of the dose rate is possible. We performed such experiments, using a dosimeter fiber and a reference fiber side by side. We determined that, in general, the scintillation mode is not a reliable detection method. First, the Cerenkov radiation signal can represent a significant fraction of the overall signal, so that when the Cerenkov signal from the reference fiber is subtracted from the scintillation signal of the dosimeter fiber, the resulting errors can be significant.

These scintillation studies highlight one of the most fundamental and most innovative aspects of this entire research program. When the fiberoptic-coupled dosimeter system is used in the OSL mode, there is no interference whatsoever from Cerenkov radiation. This is true because the radiation dose measurement is performed after the radiation source is turned off. The OSL glass stores charges, as explained above, in proportion to the radiation dose. After the radiation source is turned off, the stimulation laser is directed down the optical fiber and stimulates the release of the trapped charges. The OSL emission signal that is measured is proportional to the total number of trapped charge, and, in turn, is proportional to the total radiation dose. It is apparent that the OSL mode of operation is quite different from the scintillation mode in that it is an integrating mode that measures the accumulated dose rather than the dose rate. Since the OSL measurement is made after the radiation is turned off, then there is no background Cerenkov radiation. OSL measurements can also be obtained during the course of the irradiation by pulsing the laser, collecting the total signal and then subtracting the d.c. scintillation signal. The advantage of waiting until the radiation field is turned off is that the OSL measurement is essentially a zero-background measurement technique and provides very good signal to noise characteristics. The typical OSL signals are on the order of  $10^4$  to  $10^5$  counts per second. In addition, the OSL signal has absolutely no angular dependence. This is because, regardless of the angle of incidence of the radiation, the traps are simply stored in the glass and when they are released the photons all have the same coupling efficiency into the optical fiber for transmission to the photomultiplier tube.

A large number of experiments were performed both at NRL and NIH to fully characterize the fiberoptic-coupled dosimeter system. Individual OSL dosimeters were evaluated in both OSL mode and scintillation mode using 6 MV and 15 MV x-rays, as well as 9 MeV and 20 MeV electrons. OSL data were collected by exposing the dosimeter to radiation for a selected number of monitor units. The laser was then pulsed for a predetermined time period and the resulting stimulated luminescence collected by the photon counting modules. Scintillation data was collected by switching on data acquisition of the photon counting module prior to activating the x-ray beam and acquiring data continuously throughout the exposure. Radiation longevity, dose-response linearity, energy dependence, angular dependence, depth dose response and the relative response with field size were all studied.

An accelerated aging study was conducted on the OSL fiber dosimetry system by monitoring the performance of the dosimeters as a function of accumulated dose from 0.1 Gy to 20,000 Gy using a high dose rate  $^{60}\text{Co}$  sealed source irradiator (AECL GammaCell 220). The exposure was increased in steps of 1, 2, and 5. Between each exposure, the dosimeter was thermally annealed to deplete the stored, trapped charges. Fiber dosimeters were then irradiated using a  $^{60}\text{Co}$  teletherapy unit and the scintillation and OSL signals were measured following exposures of 1 Gy. The detector response was essentially unaffected up to a

total dose of 5,000 Gy. Beyond this, the slope of the dose response began to decrease gradually, but remained useful up to 20,000 Gy. The decrease in the slope of the response curve appeared to be due primarily to radiation-induced darkening in the 1 meter length of optical fiber rather than actual damage to the 1 mm length of OSL phosphor material.

The dose response of the OSL dosimetry system was measured for 15 MV photons and 9 MeV electrons over a dose range from 0.01 Gy to 10 Gy. A series of ten measurements was obtained for each point. The results of these measurements are shown in Figure 4. These measurements exhibit excellent linearity and reproducibility.

The energy dependence of the detector was measured for electrons over the range from 6 MeV to 20 MeV and for photons at 6 MV and 15 MV. The results of these measurements are shown in Figure 5. The detector response showed no significant energy dependence over this range. The results presented in Figures 4 and 5 are important because they demonstrate that the response of the OSL dosimeter is independent of the energy and type of radiation in the range used for teletherapy procedures.

Figure 6 demonstrates the angular dependence of the dosimeter response to radiation. Measurements were made by rotating the gantry coaxially around the fiber and in the orthogonal direction with respect to the fiber axis. In all but one case, the variation in response was less than 5%. Scintillation measurements performed at the same time showed a very large angular dependence for measurements orthogonal to the fiber axis. It is important to note that the results could not be corrected simply by subtracting the reference fiber signal. When the fiber is irradiated in this configuration, the length of fiber exposed to the beam changes with each angle. The amount of Cerenkov radiation generated within the fiber depends on the length of exposed fiber and the angle of incidence of the radiation beam with respect to the fiber axis. The intensity of the Cerenkov light is much higher in the UV and blue spectral regions and falls off as  $1/\lambda^3$ . The UV component of the Cerenkov radiation can excite luminescence from the dosimeter which adds to the scintillation signal. The amount of Cerenkov-generated UV that reaches the dosimeter is not a simple function of the length of exposed fiber because of the angular dependence of the Cerenkov radiation and the total internal reflection angle of the fiber (related to the numerical aperture (NA) of the fiber). Cerenkov UV radiation that is generated at an angle that exceeds the angle for total internal reflection suffers significant losses, so that Cerenkov radiation that is generated close to the dosimeter is much more efficient at exciting luminescence than the radiation generated further away from the dosimeter. This complex behavior will be a concern for any type of real-time scintillation dosimeter.

Figure 7 shows the dosimeter response as a function of increasing source-to-detector distance over the range from 90 cm to 120 cm for 6 MeV photons. A

least squares fit to the data shows that there is no significant variation from an expected inverse-square relationship for photons.

Figure 8 illustrates the dose rate response of the OSL fiber dosimeter. The dose rate was varied by controlling the pulse repetition frequency. In these experiments, the variation in the relative detector response over the range of 1-5 Gy/min is generally less than 2%.

Figures 9-11 demonstrate the ability of the OSL dosimeter to respond to changes in radiation energy. Figure 9 shows Tissue Maximum Ratio (TMR) measurements for 6 MV photons along with the values measured using an ionization chamber. Figure 10 shows similar measurements for 15 MV photons. In both cases, the accuracy of the OSL dosimeter is within 2% of the reference ion chamber values. For the 6 MV photons, the maximum dose occurs at a depth of 1.5 cm and for the 15 MV photon beam the dose maximum occurs at 3.5 cm. The TMR measurements include the effects of the inverse square dependence and scattering from surrounding irradiated material.

Figure 11 shows a depth dose curve measured for 9 MeV electrons. Here, data is presented both as an integrated OSL signal as well as integrated scintillation signal and compared with the reference ion chamber measurements. Excellent agreement is obtained to a depth of 4.5 cm, where lack of signal increases the error slightly.

Figures 12-13 are measurements of output factors for 6 MV photons. These show how detector response is affected by increasing scatter radiation. Figure 12 is a standard square field output factor table measured by OSL dosimetry, MOSFET and ion chamber. Error bars of 2% are placed on the reference ion chamber values. Measurements for both MOSFET and OSL are shown to agree to within 2% of the reference value. Figure 13 is the output factor graph for stereotactic applicators ranging from 1.25 cm to 4.0 cm diameter. In this case, 1% error bars are attached to the ion chamber values for reference. In all cases, the OSL dosimeter agrees with ion chamber values to within 1%. It is of note that, for the smallest applicator, a convolution correction was applied to the initial ion chamber measurement to correct for non-uniform response across the detector surface, which resulted in a "partial volume" measurement error of about 2%. Such a convolution correction was not required for the OSL dosimeter data due to the outstanding spatial resolution of the fiberoptic dosimeter.

All of the above characterizations were performed using solid water phantoms under clinical conditions. The fiberoptic-coupled dosimeter has been severely and exhaustively tested against the best and most carefully calibrated equipment available at the NCI. In every case, as shown above, the fiberoptic-coupled dosimeter met or exceeded the performance of the MOSFETs and Si diodes. The results agreed extremely closely, often to within 1%, with the best and most accepted numbers obtained using calibrated ion chambers.

The performance of the single channel, fiber optic-coupled OSL dosimeter was evaluated in a clinical setting. It was directly compared to a MOSFET dosimeter and a Si diode dosimeter. Skin entrance and exit doses were measured for two patients receiving external beam radiotherapy. The fiber-optic coupled dosimeter was taped onto the patient's skin adjacent to the MOSFET and silicon diode dosimeters. The MOSFET and fiber dosimeters provide skin entrance dose information while the diode indicates the dose at  $d_{max}$  due to the presence of the intrinsic build-up layer. The results obtained using the MOSFET and the optical fiber dosimeter were nearly identical for the two patients.

**Task 3: Develop a patient dose verification system that utilizes a multiplexed array of eight fiber-optic-coupled dosimeters.**

- Study characteristics of the system using tissue equivalent phantoms.
- Perform dose verification on ~20 patients receiving prostate beam therapy treatments.
- Assess the utility of the system.

The development of a multichannel dosimeter system was a key goal of this research program. In successfully completing the Task 1 and Task 2 goals we demonstrated the superiority of the OSL glass fiber dosimeter in terms of performance and added functionality compared to conventional electronic remote dosimeters. However, in order to establish the utility of such a system for actual patient dose verification the single channel results had to be extended to multiple channels. Patient dose verification requires the simultaneous measurement of dose at 8 to 12 locations. The goal of Task 3 was to develop a cost-effective system that had 8 multiplexed sensors, however, our current planning is directed toward the development of a system with two dozen or more sensors.

Our initial efforts toward the development of a multichannel system involved using a single detector and multiplexing the dosimeter fibers. The idea was to sequentially read out the dose from each multiplexed fiber. The approach that we originally proposed was the use of a fiber switcher. Problems with this approach became evident quite early in the development. The optical switches available at that time were extremely expensive and not particularly rugged. The switches that were available were designed for single mode fiber use and switched between channels in about 0.5 seconds. Single mode fibers are very small, the core is on the order of a few microns in diameter. The optical fibers we use in the fiberoptic-coupled dosimeter are all multimode fibers that have core diameters of 200 microns to 600 microns. Although the manufacturers claimed they could design, build and deliver a 1X8 multimode fiber switcher, the cost quoted was excessive and the performance was diminished compared to the single mode switchers. Part of the difficulty was that the inertia of the heavier multimode fibers caused the switching time to increase significantly from 0.5 seconds. For these reasons we abandoned the multiplexing approach that relied on mechanical fiber switching.

The approach we decided to pursue was inspired by our previous experience with fiber splitters. We designed a seven-channel fiberoptic-coupled dosimeter using fiberoptic bundles to split the stimulation laser into seven channels and to direct the stimulation light to seven photomultiplier tubes. The fiberoptic bundles have seven fibers arranged in a pattern that has a single fiber in the center that is surrounded by a hexagon of six fibers. The output of a fiberoptic-coupled, 790 nm, 1.2 Watt GaAlAs diode laser is directed into a fiberoptic bundle that consists of seven individual fibers. These fibers are then split apart and coupled to seven-fiber bundles at each of the dosimeter fibers. Six of the seven fibers that make up each of these bundles are used to direct the signal light to a photomultiplier tube detector (photon counting module, PCM). The intensity of the signal light measured with the PCM is proportional to the absorbed radiation dose. The use of the fiber bundle technology as opposed to using discrete optical elements such as lenses, mirrors and beamsplitters results in considerable cost savings, reduced weight, and improved stability. We have built this dosimeter system with a seven channel capacity. However, in order to keep costs down, we have actually demonstrated the simultaneous use of only four of the seven channels. The greatest expense associated with each channel is the photomultiplier tube, which costs ~\$1100 per tube. A schematic of the four-channel dosimeter is shown in Figure 14.

Figure 14 shows that the output from each of the four photomultiplier tubes connects to a personal computer. It is clear that with a multichannel dosimeter the data transfer and data storage problems are significantly more complex. In order to effectively address this issue we engineered the hardware and software that were needed to provide for automated data collection and analysis. An RS232 interface card was used and several versions of a Lab-View-based software package were written specifically to control all aspects of the data collection. The program allows the simultaneous measurement of the scintillation signals for all seven channels and provides real-time outputs of the instantaneous dose rate and the accumulated dose. The program automatically initiates the OSL readout at a fixed time following the radiation exposure and calculates the accumulated dose. The automation of the dosimeter has led to improved performance in terms of reproducibility and data file management. The Lab-View program can be compiled and run using any PC. The program is menu driven and is extremely user friendly.

The four-channel, fiberoptic-coupled dosimeter system is currently undergoing a similar battery of tests as described for the single channel dosimeter described in Task 2. The multichannel system uses fiberoptic bundles and multiple photomultiplier tubes and is really properly described as an optimized system of four (or seven) single-channel systems. The performance of each channel in the multichannel dosimeter is expected to be identical to the performance of the single-channel dosimeter. All preliminary data support this expectation.

As stated previously, we have begun to design a radically different multichannel dosimeter that will potentially provide for dozens of channels that can be simultaneously monitored. This will be accomplished through the use of a linear CCD array as the photon detector. The CCD will replace the individual photomultiplier tubes. With an appropriate CCD detector in which the individual pixels can be binned as desired, it should be possible to mate a linear row of dozens of fibers to the binned pixels. We have purchased a linear CCD array and are in the process of designing an appropriate multichannel dosimeter. The cost of a good CCD array is about \$6,000, so the CCD detector becomes cost effective once the number of channels exceeds five or six.

The performance of a four-channel, fiber-optic coupled OSL dosimeter was evaluated in a clinical setting. It was directly compared to other accepted clinical devices, including a MOSFET dosimeter, Si diode dosimeter and ionization chamber and TLDs. Skin entrance and exit doses and  $d_{\max}$  doses were measured in a single patient receiving total body external beam radiotherapy. A different set of optical fiber dosimeters was used. The optical fiber cable that connects the radiation sensitive element to the 10-m long fiber patch cord was obtained from a different supplier, 3-M. Unfortunately, the 3-M fiber exhibited a field-size-dependent output signal. Dose measurements obtained using this fiber dosimeter were considerably higher than the results obtained from the silicon diode and MOSFET dosimeters. The fiber dosimeter had performed well during characterization measurements on phantoms using relatively small beam field sizes, 5-cm to 20-cm. The TBI set-up resulted in an exposure of more than 1 meter of the fiber to the radiation field. This negative result identified an important manufacturing consideration. Any connecting fibers that are to be used with the fiber dosimeter system must be selected to avoid this type of interference. Two optical fiber suppliers have been identified so far that produce suitable materials, Fiberguide Industries and Polymicro Technologies.

## Key Research Accomplishments

- Development of doped fused quartz OSL glass phosphors having characteristics that are well-suited for scintillation mode and OSL mode dose measurement, including optimal trap energy distribution, low fading, good sensitivity and linear response over a wide dynamic range.
- Fabrication of OSL glass fibers and fusion of the fibers to silica optical fiber patchcords.
- Design of light-tight fiberoptic-coupled dosimeter that does not heat when laser stimulation light is present.
- Designed and built first single channel, laser-based readout system using discrete mirrors and beamsplitters.
- Designed and built second single channel, laser-based readout system using fiberoptic splitters and no discrete optics.
- Performed exhaustive characterization of the performance of the single channel, fiberoptic-coupled dosimetry system in both scintillation and OSL modes using 6 MV and 15 MV x-rays, as well as 9 MeV and 20 MeV electrons.
  - Accelerated aging study showed dosimeter response was essentially unaffected up to a total dose of 5,000 Gy.
  - The dose response, measured for 15 MV photons and 9 MeV electrons over a dose range from 0.01 Gy to 10 Gy, is extremely linear and reproducible.
  - The response, measured for electrons over the range from 6 MeV to 20 MeV and for photons at 6 MV and 15 MV, is independent of energy and radiation type.
  - The dosimeter response in scintillation mode is highly angle dependent.
  - The dosimeter response in OSL mode is independent of angle.
  - The dosimeter response is independent of dose rate.
  - Side by side comparisons of the OSL dosimeter with Si diodes, MOSFETs and ionization chambers show that the fiberoptic-coupled OSL dosimeters perform as well or better than current technologies in those situations where direct comparisons can be made.
- The performance of a single-channel, fiber-optic coupled dosimeter was successfully evaluated in clinical trials on two patients, side-by-side with accepted dosimeters.
- Designed and built a seven-channel fiberoptic-coupled dosimeter and characterized its performance using four channels.
- The performance of a multi-channel, fiber-optic coupled dosimeter was evaluated in a clinical trial of TBI on one patient, side-by-side with accepted dosimeters.
- Designed and built a hardware interface between the fiberoptic-coupled dosimeter and a personal computer.
- Wrote a Lab-View-based software package to control all aspects of data collection and display with the multichannel OSL dosimeter.

## Reportable Outcomes

R. Altemus, R. Miller, H. Ning, A. Huston, B. Justus and P. Falkenstein, "Clinical Demonstration of Optically Stimulated Luminescent Fiber and Film Dosimetry Systems," European Society for Therapeutic Radiology and Oncology, Istanbul, Turkey, 19-23 Sept., 2000.

A.L. Huston, "Optical Fiber Dosimeters," Invited presentation, Conference on Lasers and Electro-Optics/Europe, Nice, France, 10-15 September, 2000.

R.W. Miller, A. Huston, B. Justus, H. Ning, S. Worlely, T. Bevels, R. Altemus, C. N. Coleman, "Dosimetric Characteristics of An Optically Stimulated Luminescent (OSL) Fiberoptic Dosimetry System," 2000 World Congress on Medical Physics and Biomedical Engineering, Chicago, IL, 23-28 July, 2000.

A. L. Huston and B. L. Justus, "Optically Stimulated Luminescent Fiber Optic Radiation Dosimeter," U. S. Patent 6,087,666, awarded 11 July, 2000.

A.L. Huston and B.L. Justus, "In vivo radiotherapy dose monitoring system", OFS 13<sup>th</sup> International Conference on Optical Fiber Sensors, 12-16 April 1999, Kyongju, Korea.

A. L. Huston, B. L. Justus, P. Falkenstein, R. W. Miller, H. Ning and R. Altemus, "Remote Optical Fiber Dosimetry," INVITED, to be presented, 13<sup>th</sup> International Solid State Dosimetry Conference, Israel, July, 2001, and to be published in Nuclear Instruments and Methods B.

## Conclusions

The ability to accurately and conveniently perform *in-vivo* dosimetry is currently a critical need in the radiotherapy field. Radiotherapy techniques, such as conformal radiotherapy (CRT), intensity modulated radiotherapy (IMRT) and high dose rate brachytherapy, are quite complex and require careful control of the dose rate, total dose and dose distribution for greatest effectiveness and safety. Currently, there are no dosimetry technologies available that can monitor these quantities on-line, during a radiotherapy treatment. In addition, there are no currently available dosimetry technologies that can provide dose information at and near tissue, *inside the body*, that is undergoing radiation treatment.

The primary goal of this research program has been to fill this void by providing small, reliable and accurate fiberoptic coupled OSL dosimeters that can be used for real-time, *in vivo* patient dose verification during prostate cancer radiotherapy treatments and will improve the therapeutic outcome of the treatments. The small size of the dosimeter fibers permit their use in medical catheters and brachytherapy needles and afterloaders. Placement of the dosimeter fibers at multiple points within and around the prostate will ultimately provide the ability to adjust the treatment plan on-line to insure that the target dose is properly delivered and that damage to surrounding tissues is minimized.

The results of the research performed during this program have been successful to a degree far beyond the expectations of the proposal. OSL glass fiber dosimeters were successfully attached to standard silica fibers. A laser-based readout unit was designed and built and remote radiation sensing measurements were successfully demonstrated. The fiberoptic-coupled dosimeter was exhaustively tested in side by side comparisons with established technologies such as ionization chambers, MOSFET dosimeters, Si diode dosimeters and thermoluminescence dosimeters. These comparisons were conducted in phantoms under actual clinical conditions using the same radiotherapy machines at the National Cancer Institute that are also used for patient treatment. In every case the fiberoptic-coupled dosimeter provided the correct measurement, often with accuracy to within 1% of the accepted values. The characterization experiments included measurement of the dose response, the resistance to radiation damage, the energy dependence of the response, the angular dependence of the response and the dose rate dependence of the response. The performance of a single-channel, fiber-optic coupled dosimeter was evaluated in clinical trials on two patients, side-by-side with accepted dosimeters. The dosimeter performed as well as the accepted dosimeters but has measurement capabilities that are unique to the fiber dosimeter.

A multichannel, fiberoptic-coupled dosimeter was designed and built that simultaneously measures the absorbed dose at seven independent locations. This dosimeter system was interfaced with a personal computer and a Lab-View-based software program was written to control all aspects of the data collection

and display. This system has also been characterized in studies using phantoms and has been evaluated on a single patient undergoing total body irradiation.

The bottom line payoff of this research is self-evident. The fiberoptic-coupled OSL dosimeter will enhance the effectiveness of prostate radiotherapy procedures, reduce negative side effects such as death, incontinence and impotence, and improve the quality of life for prostate cancer survivors.

The initial results obtained from this Phase I study are extremely promising. However, additional and more comprehensive patient trials must be completed to properly evaluate the full potential of this technology. The authors intend to apply for Phase II support of additional clinical research in order to complete the work started under this program.

Finally, the investigators wish to thank the U. S. Army Medical Research and Materiel Command for their support of this research.

## References

1. Cameron, J.R., Suntharalingam, N. and Kenney, G.N. Thermoluminescent Dosimetry, Univ. Wisconsin Press, Madison, WI, 1968.
2. Attix, F.H. Introduction to Radiological Physics and Radiation Dosimetry. Wiley, New York, 1986.
3. Howlett, S.J. and Kron, T. Evaluation of p-type semiconductor diodes for *in-vivo* dosimetry in a 6MV x-ray beam, *Aust. Phys. Eng. Sci in Med.* **19**: 2, 83-93, 1996.
4. Kember, N.F. ed. Medical Radiation Detectors: Fundamental and Clinical Aspects. IOP Press, Philadelphia, 1994.
5. Nilsson, B., Ruden, B.I. and Sorcini, B. Characteristics of silicon diodes as patient dosimeters in external radiation therapy, *Radio. And Oncol.* **11**:3, 279-288, 1988.
6. Grussel, E. and Rikner, G. Radiation damage induced dose rate non-linearity in an n-type silicon detector. *Acta Radiologica.* **23**: 6, 465-469, 1984.
7. Shackford, H. and Bjarngard, B.E. Disturbance of diode dosimetry by radiofrequency radiation, *Med. Phys.* **22**: 6, 807, 1995.
8. Introduction to the MOSFET Dosimeter. Technical Note No. 4, Thomson and Nielsen Electronics Ltd. Nepean, Ontario, Canada, 1996.
9. Cygler, J., Soubra, M., Szanto, J., Mackay, G.F. and Thomson, I. Application of MOSFET dosimetry in TBI and HDR treatments. Thomson and Nielsen Electronics Ltd. Nepean, Ontario, Canada unpublished.
10. Gladstone, D.J., Lu, X.Q. and Humm, J.L. A miniature MOSFET radiation dosimeter probe. *Med Phys.* **21**: 11, 1721-1728, 1994.
11. Soubra, M., Cygler, J. and Mackay, G. Evaluation of a dual bias dual metal oxide-silicon semiconductor field effect transistor detector as radiation dosimeter. *Med. Phys.* **21**: 4, 567-572, 1994.
12. Kiefer, H. and Maushart, R. Radiation Protection Measurement. Pergamon, New York, 1972.
13. Attix, F.H. Topics in Radiation Dosimetry. Academic Press, New York, 1972
14. Justus, B.L., Johnson, T.L., and Huston, A.L. Radiation dosimetry using thermoluminescence of semiconductor-doped vycor glass. *Nucl. Inst. And Meth. Phys. Res. B* **95**, 533, 1995.

15. Justus, B.L. and Huston, A.L. Ultraviolet dosimetry using thermoluminescence of semiconductor-doped vycor glass. *Appl Phys.Lett.* **67**, 1179, 1995.
16. Justus, B.L., Huston, A.L. and Johnson, T.L. Laser-heated radiation dosimetry using transparent thermoluminescent glass. *Appl. Phys. Lett.* **68**, 1, 1996.
17. Huston, A.L., Justus, B.L. and Johnson, T.L. Fiber-optic-coupled, laser heated thermoluminescence dosimeter for remote radiation sensing. *Appl. Phys. Lett.* **68**, 3377, 1996.
18. Justus, B.L., Rychnovsky, S., Miller, M.A., Pawlovich, K.J. and Huston, A.L. Optically stimulated luminescence radiation dosimetry using doped silica glass. *Rad. Protect. Dosimetry*, **74**, 151, 1997.
19. A. S. Beddar, T. R. Mackie and F. H. Attix, Water-equivalent plastic scintillation detectors for high energy beam dosimetry: II. Properties and measurements. *Phys. Med. Biol.* **37**, 1901, 1992.
20. D. Letourneau, J. Pouliot and R. Roy, Miniature scintillating detector for small field radiation therapy. *Med. Phys.* **26**, 2555, 1999.

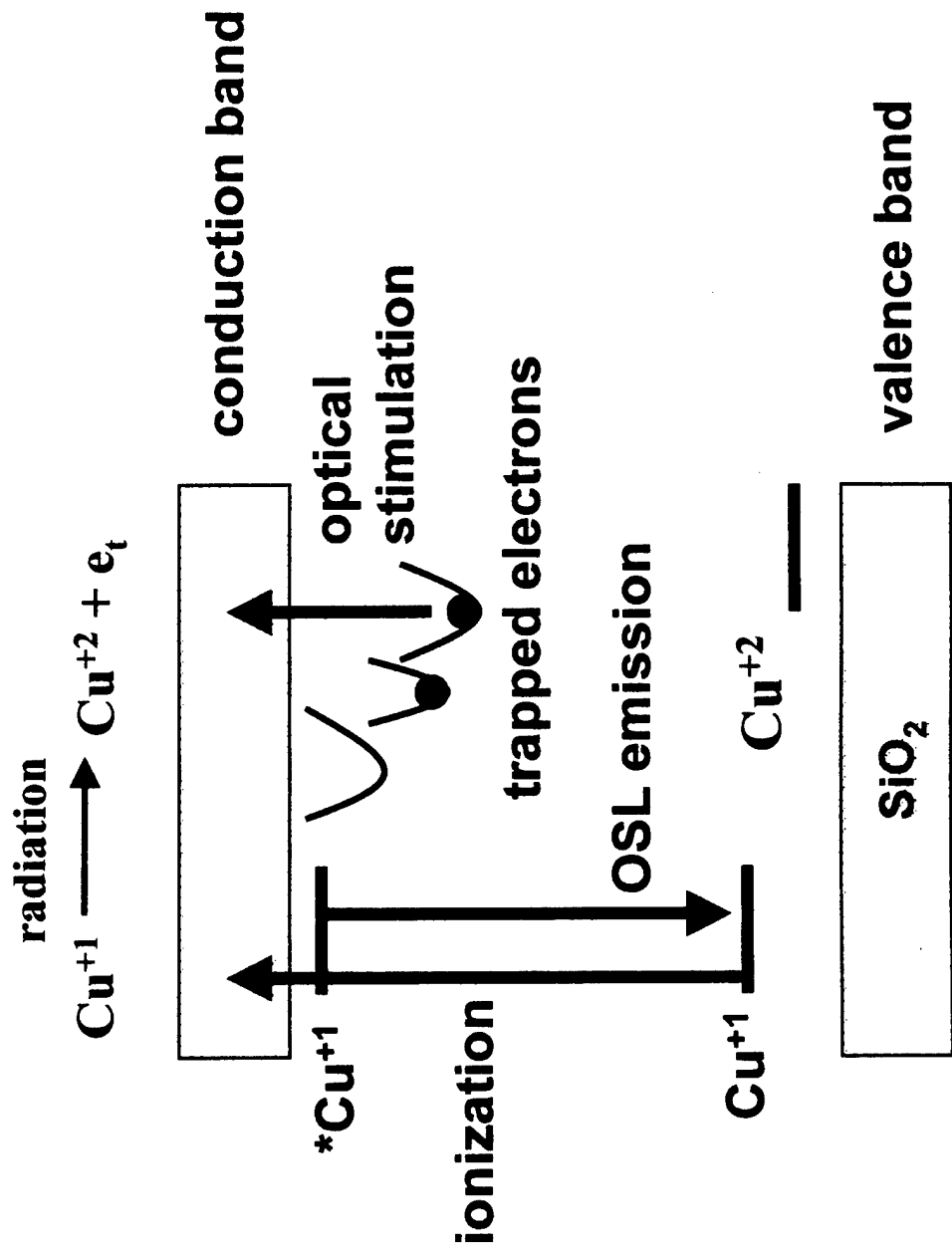

**Figure 1: Energy diagram illustrating generation, trapping and release of charges in OSL glass.**

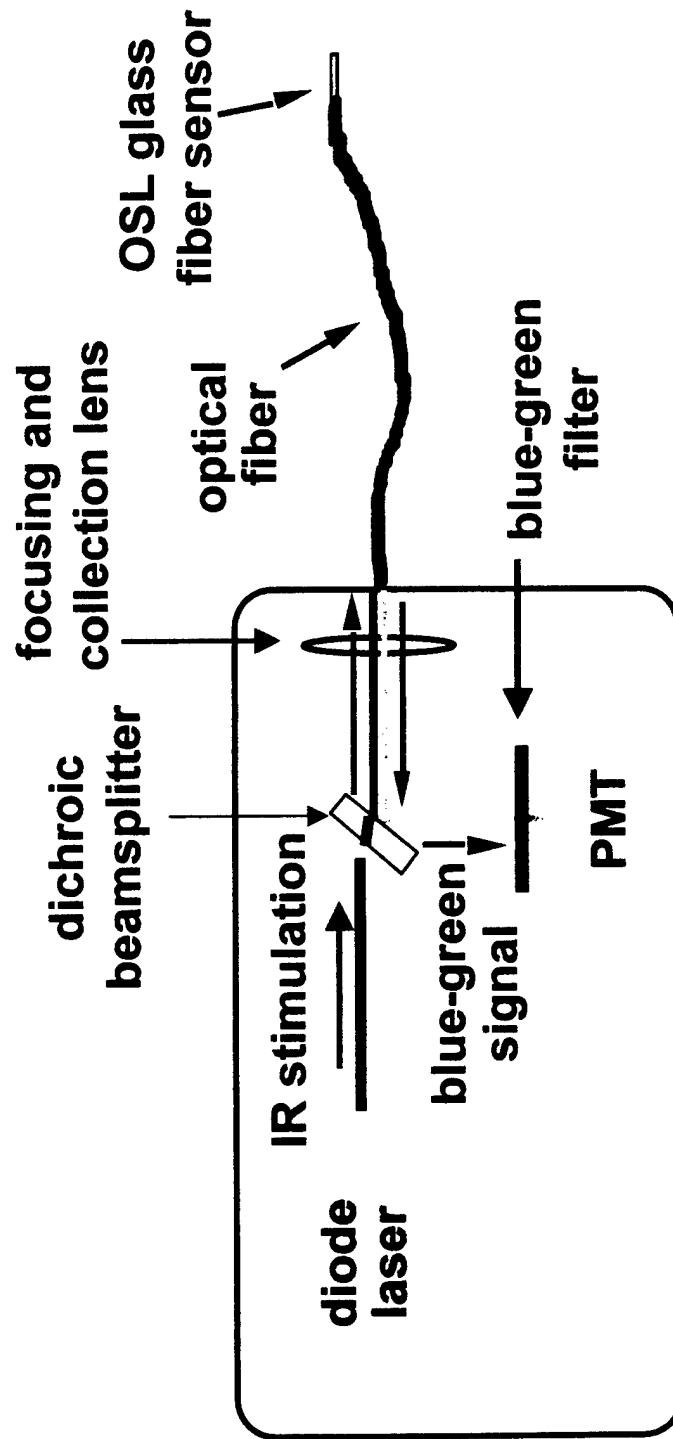

**Figure 2: Schematic of single channel remote dosimeter using discrete optics.**

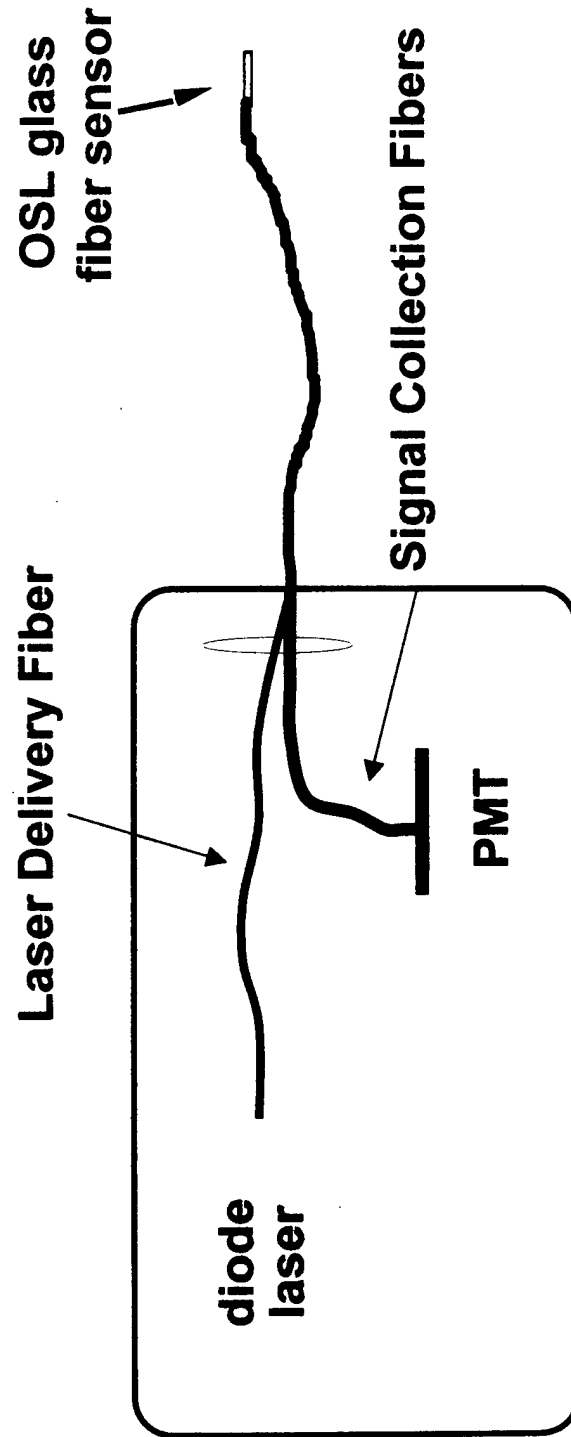

**Figure 3: Schematic of single channel remote dosimeter using optical fiber bundle technology.**

### Detector Response Linearity for Photons and Electrons

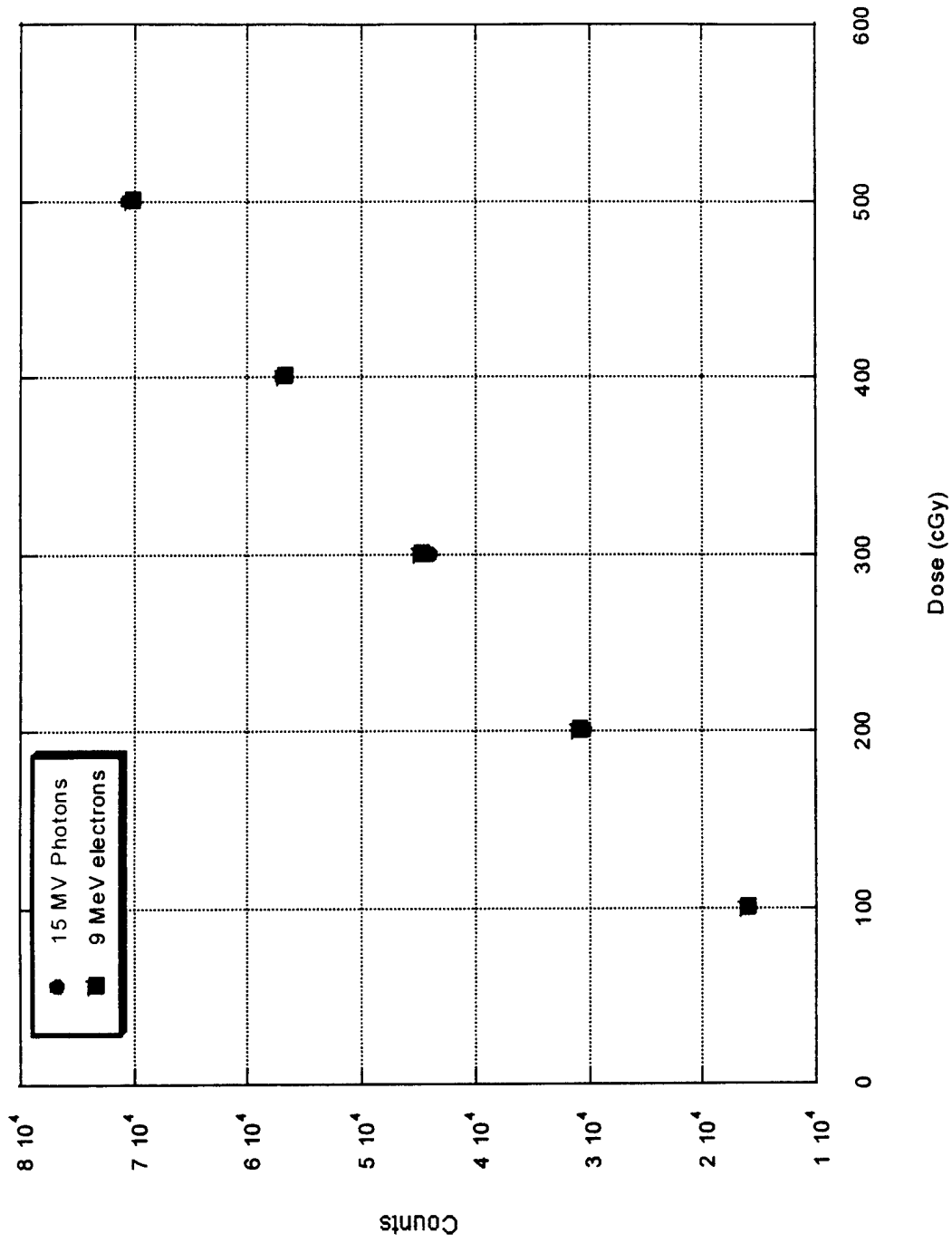

Figure 4. Detector dose-response linearity for photons and electrons

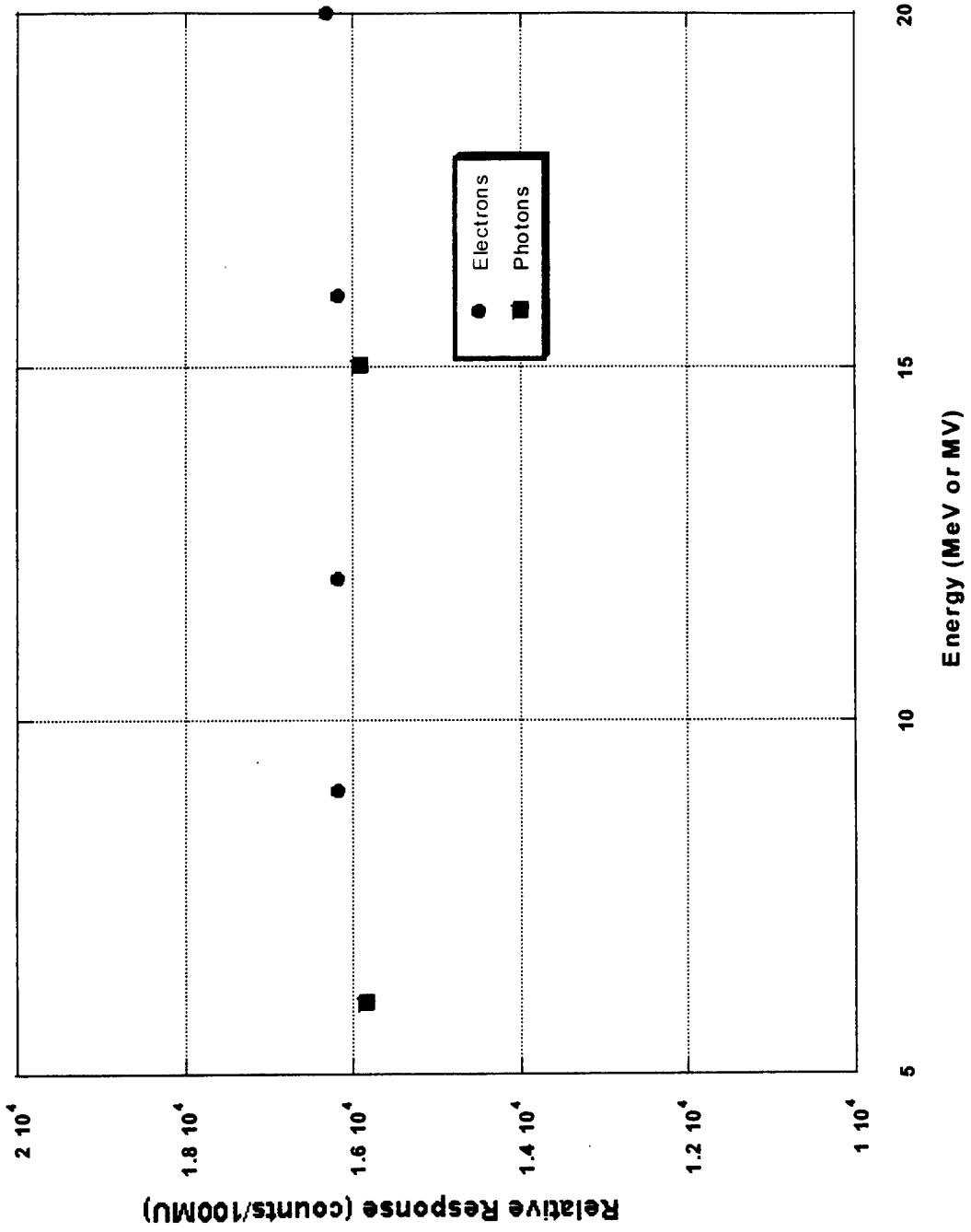

Figure 5. Response of OSL detector to photons and electrons

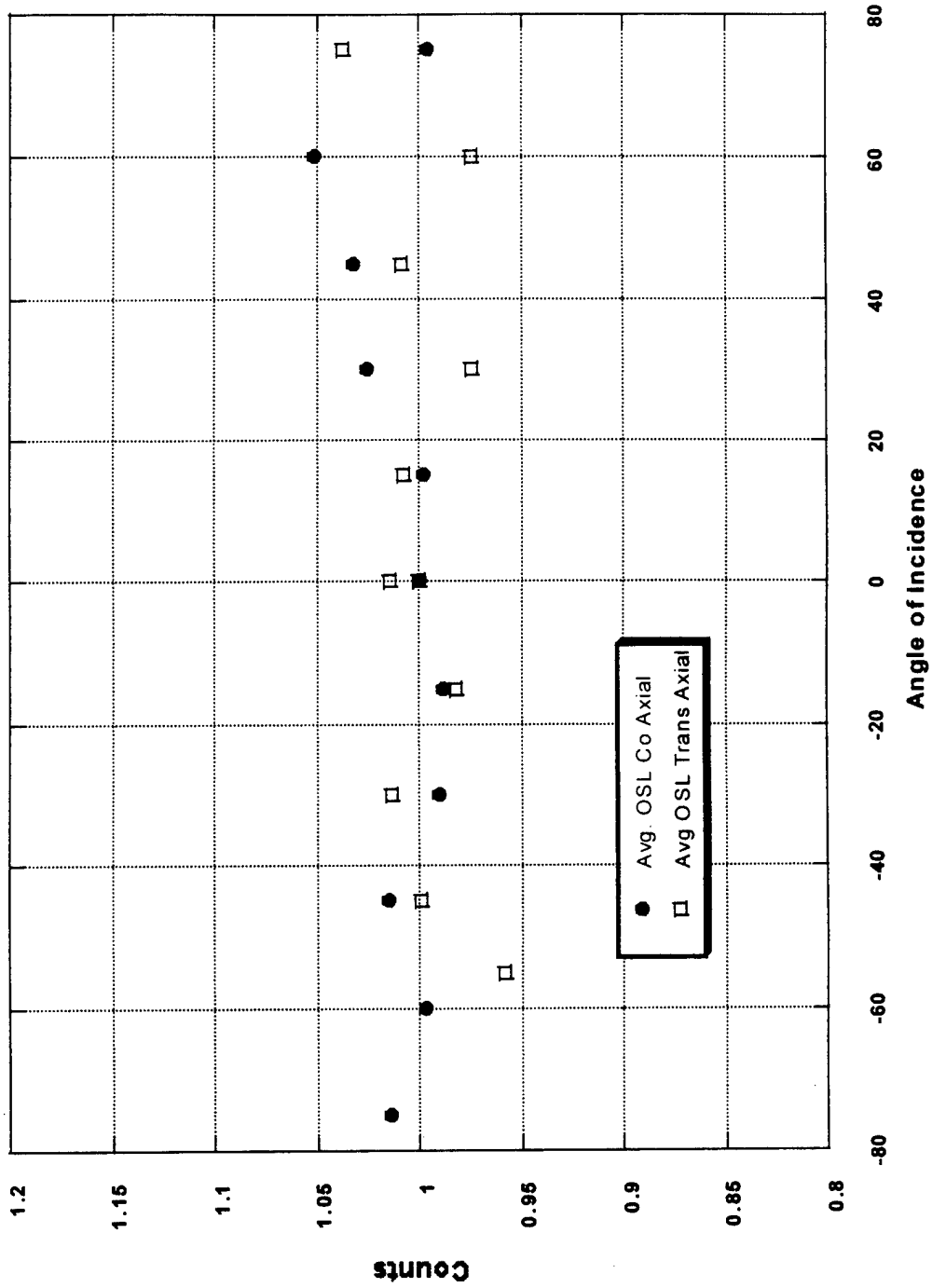

Figure 6. Directional dependence of OSL response (6 MV photons)

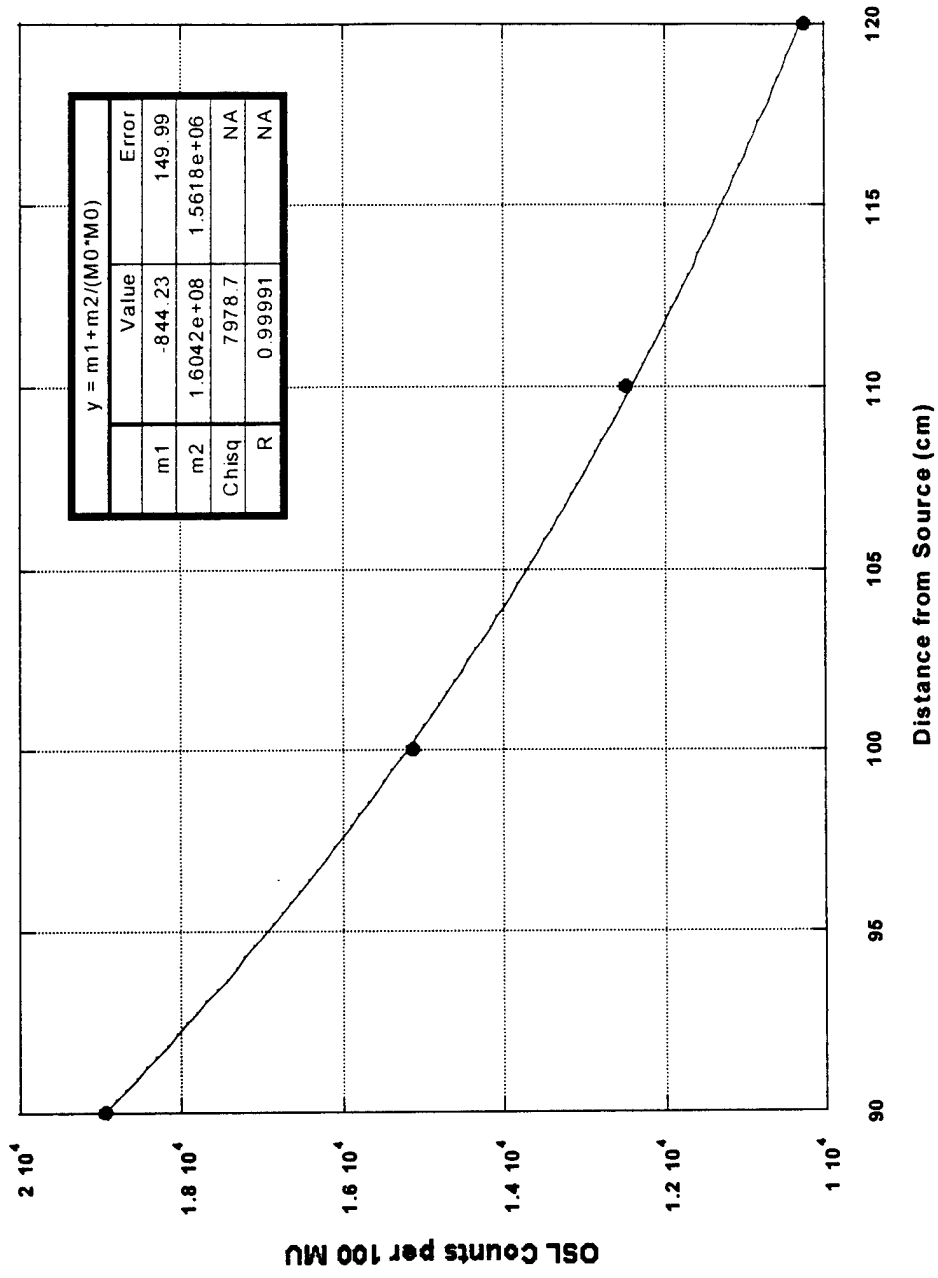

Figure 7. Inverse square dependence of OSL signal (6 MV photons)

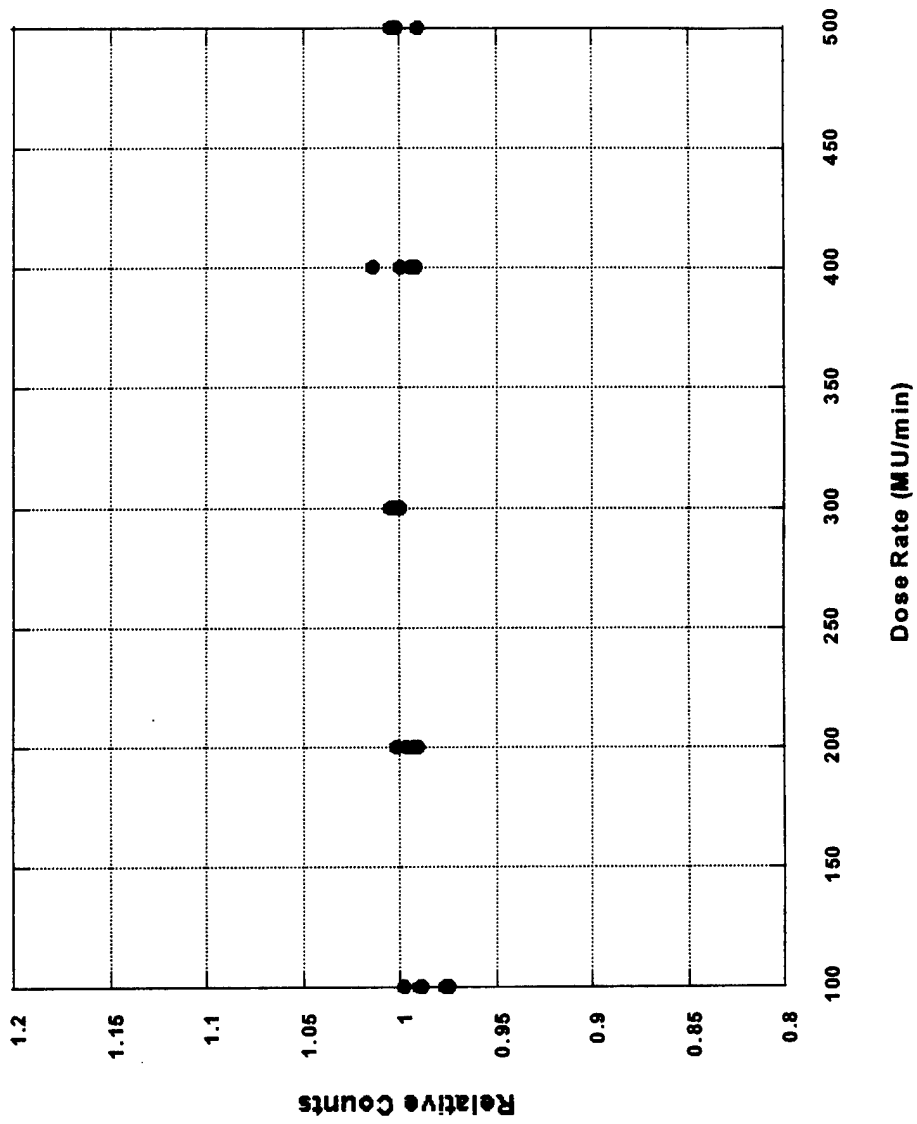

Figure 8. Dose rate dependence of OSL dosimeter (6 MV photons)

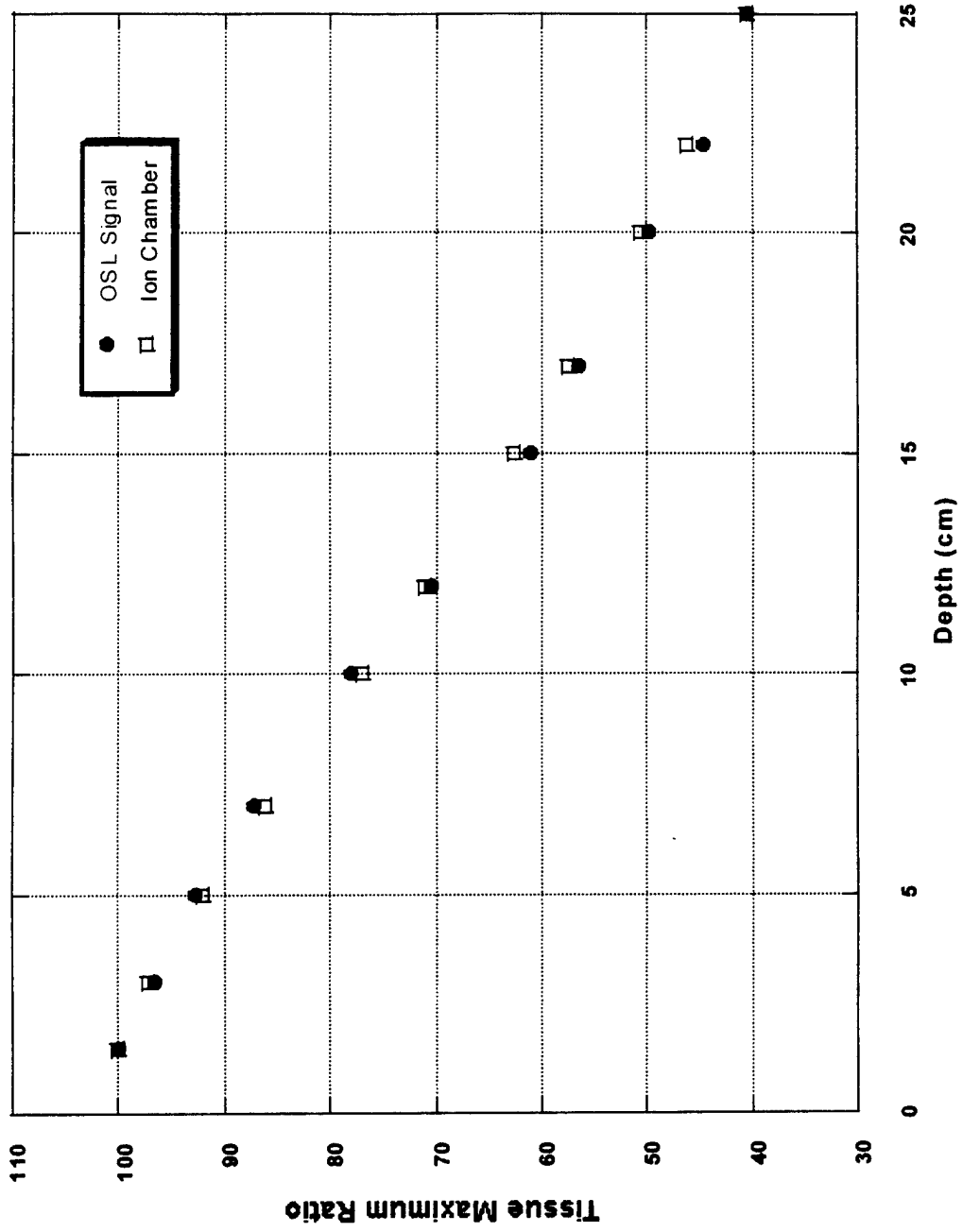

Figure 9. TMR for 6 MV photons measured with OSL dosimeter and with ion chamber

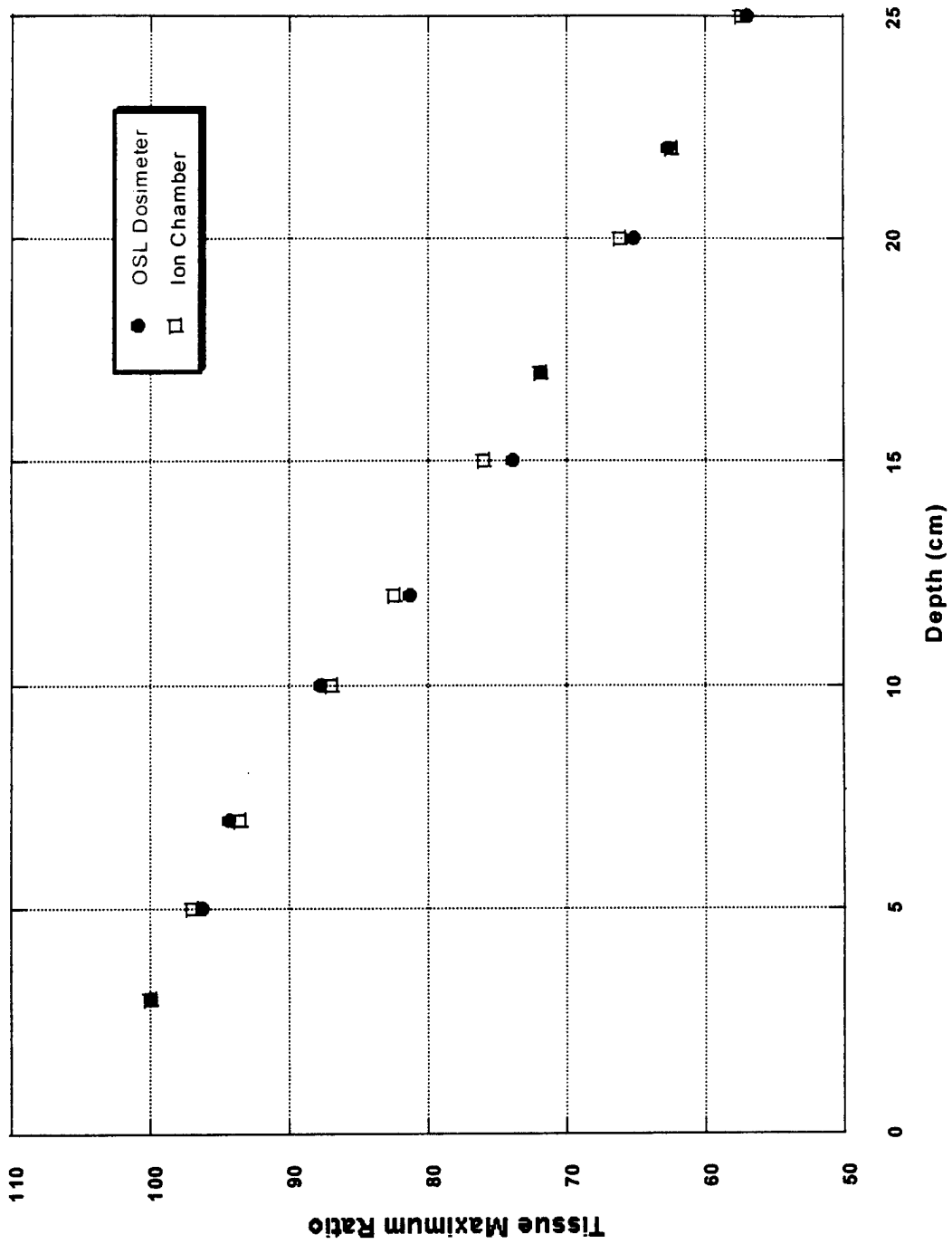

Figure 10. TMR for 15 MV photons measured with OSL dosimeter and with ion chamber

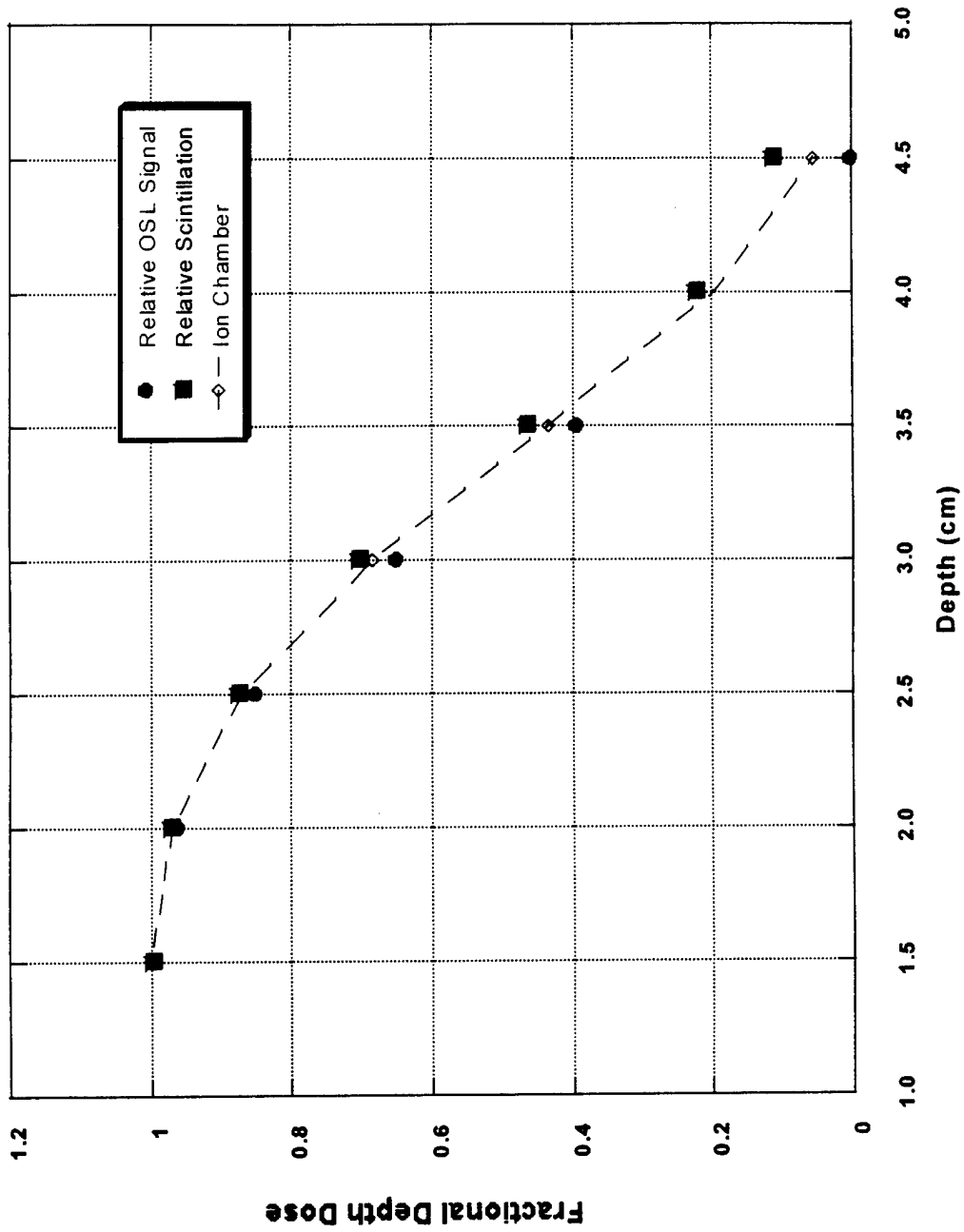

Figure 11. Fractional depth dose measured for 9 MeV electrons using OS� dosimeter and ion chamber

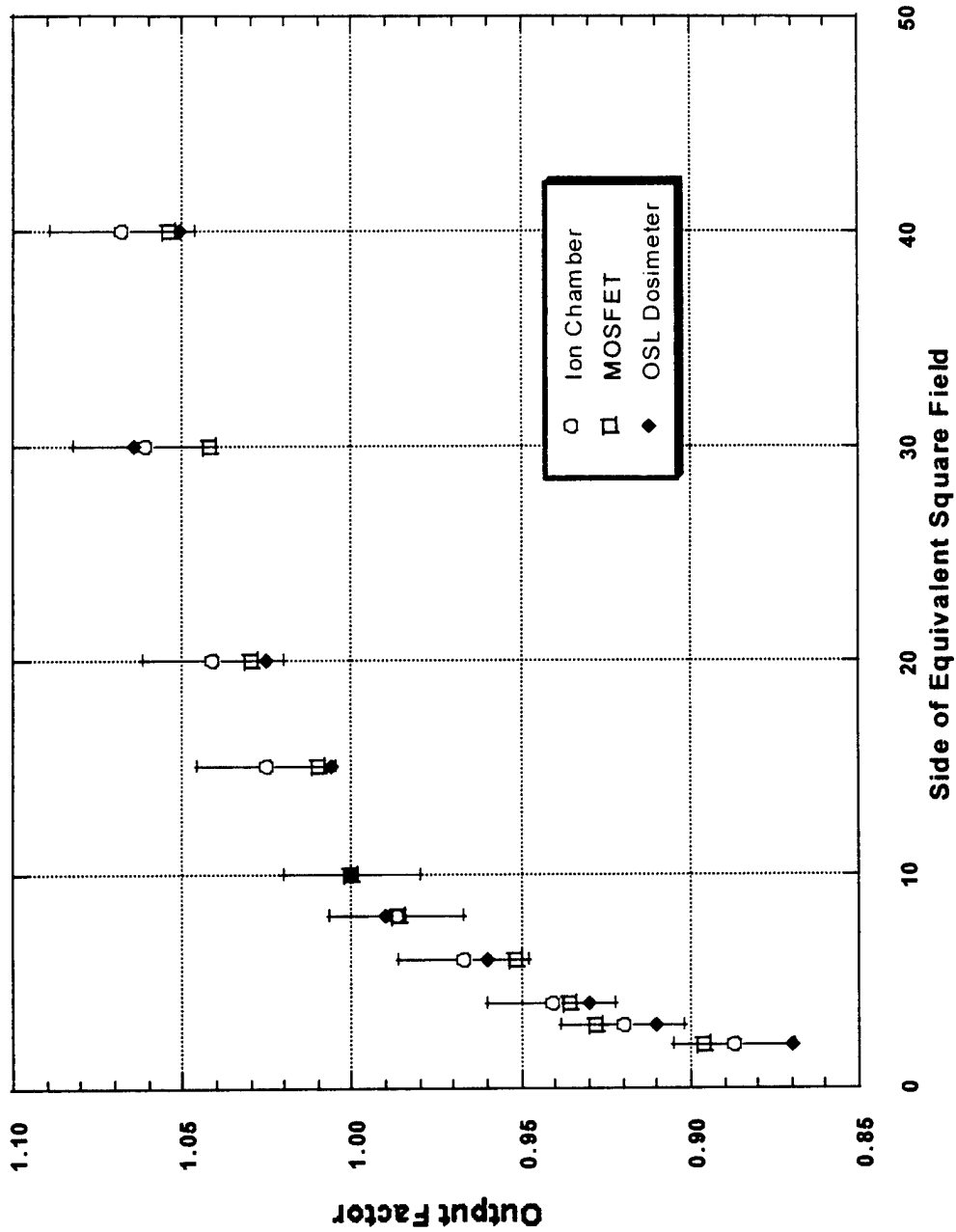

Figure 12. Square field output factors for 6 MV photons

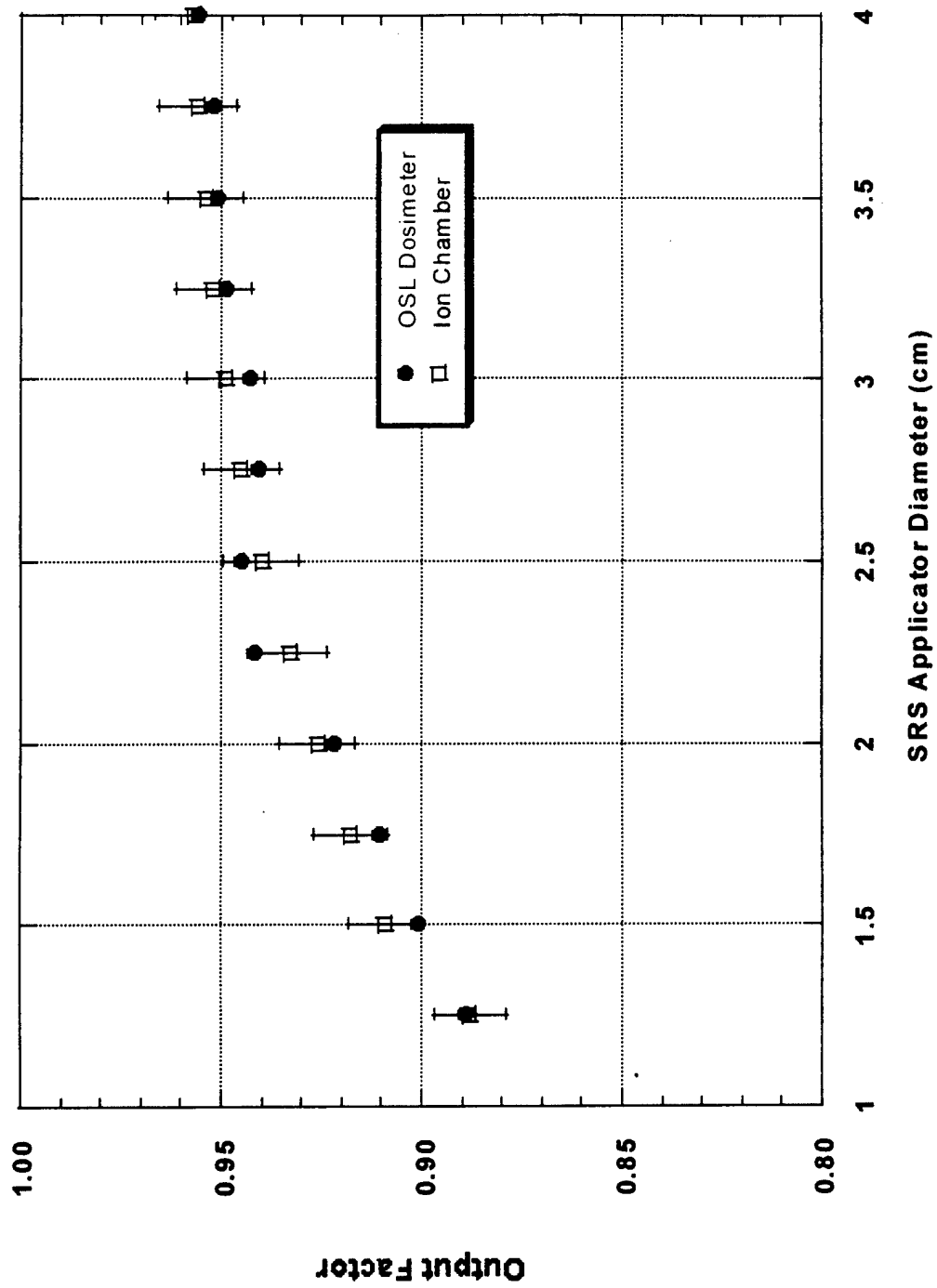
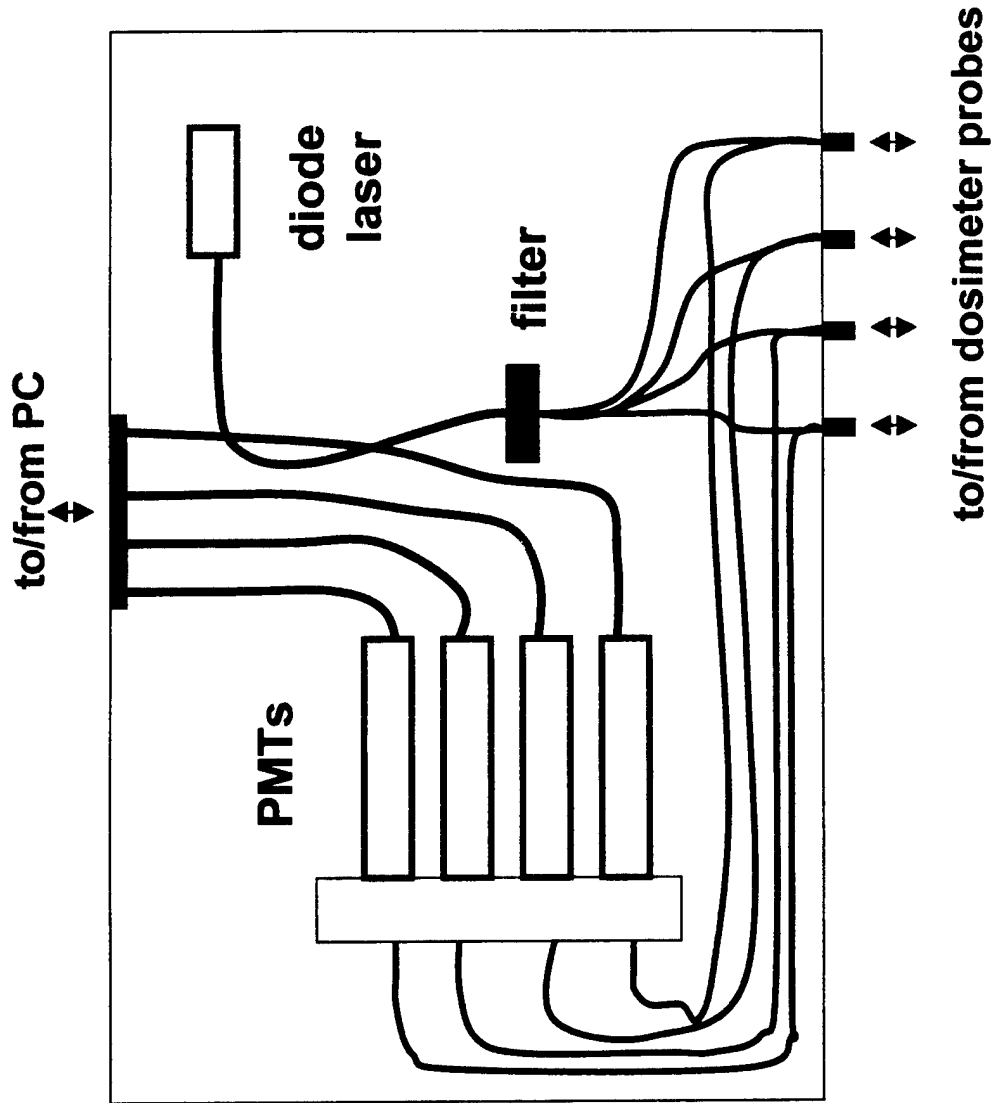

Figure 13. Comparison of measured output factors for stereotactic applicators (6 MV photons)



**Figure 14. Four-channel, OSL optical fiber dosimeter system.**

## Bibliography

1. Persons receiving support from the research effort:

Alan L. Huston

Brian L. Justus

2. Abstracts of meetings (see pages 39 – 45)

R. Altemus, R. Miller, H. Ning, A. Huston, B. Justus and P. Falkenstein, "Clinical Demonstration of Optically Stimulated Luminescent Fiber and Film Dosimetry Systems," European Society for Therapeutic Radiology and Oncology, Istanbul, Turkey, 19-23 Sept., 2000.

A.L. Huston, "Optical Fiber Dosimetry," Invited presentation, Conference on Lasers and Electro-Optics/Europe, Nice, France, 10-15 September, 2000.

R.W. Miller, A. Huston, B. Justus, H. Ning, S. Worlely, T. Bevels, R. Altemus, C. N. Coleman, "Dosimetric Characteristics of An Optically Stimulated Luminescent (OSL) Fiberoptic Dosimetry System," 2000 World Congress on Medical Physics and Biomedical Engineering, Chicago, IL, 23-28 July, 2000.

A. L. Huston and B. L. Justus, "Optically Stimulated Luminescent Fiber Optic Radiation Dosimeter," U. S. Patent 6,087,666, awarded 11 July, 2000.

## Clinical Demonstrations of Film and Fiber Optically Stimulated Luminescent Dosimetry Systems

R. Altemus, R.W. Miller and H. Ning  
Radiation Oncology Branch  
Radiation Oncology Sciences Program, DCT  
National Cancer Institute, National Institutes of Health  
Bethesda, MD 20892

And

A.L. Huston and B.L. Justus  
Optical Sciences Division Code 5611  
Naval Research Laboratory  
Washington, D.C. 20375

New dosimetry systems using optically stimulated luminescent (OSL) phosphors have been *developed* and tested in a clinical setting. The OSL phosphors, developed at the US Naval Research Laboratory, are activated copper ion doped glasses that have *exceptional* optical transparency and can be fabricated into sheets, rods, or fibers. The luminescence is proportional to the radiation exposure. Two separate systems will be described, one uses thin fibers for point dose verification and the other uses OSL film for 2D imaging and dose verification.

Glass fibers are drawn to ~100-400 micron diameters and fused to commercial optical fiber. The fiberoptic coupled system uses a 800 nanometer diode laser to stimulate luminescence from the phosphor and PMT arrays to record both instantaneous dose rate (used in scintillation mode) and total cumulative dose (OSL mode) at multiple sites during radiotherapy treatments. This device offers several potential advantages over existing dosimetry systems, including: the small size of the detector, lossless transmission of the signal through the optic fiber without degradation due to a high radiation or high radiofrequency environment, tissue equivalence of the detector, measurement of the true surface dose, and the ability to measure both instantaneous dose rate and accumulated dose. Applications are varied and include: Micro dosimetry, use in brachytherapy catheters, invasive dosimetry with O<sub>2</sub> measurements, and standard radiotherapy.

A new radiation dose imaging technology is being developed for IMRT and conformal radiotherapy treatment plan verification. Imaging sheets are fabricated using a finely powdered OSL glass material that is incorporated in an acrylic binder and applied to a transparent, flexible polyester substrate. With exposure to radiation, the film records and stores images using the electron trapping characteristics of the copper-doped glass. Images are read out by illuminating the OSL glass with near-infrared light from a low cost 800 nm diode laser and synchronously detecting the resultant, visible, optically stimulated luminescence signal using a PM tube. The laser output is directed to the imaging sheet using a 1 meter long fiber bundle consisting of 7, 400 micron diameter optical fibers in a hexagonal close-packed array. The central fiber delivers to stimulation light and the surrounding six fibers are used to collect and direct the signal to the PM tube. Focusing optics are not required since the tip of the fiber is positioned less than 50 microns above the surface of the OSL sheet. The resolution of the current system is on the order of 0.5mm due to the diameter of the delivery fiber. Resolutions on the order of 0.1mm can be obtained

by using smaller diameter fibers. Applications include: versatile geometry, 2D arrays, stacks of 2-D sheets for 3-D dose mapping, imaging inside of water phantoms, and autoradiography.

Studies indicated that these OSL detector dose responses were linear from  $10^{-2}$  Gy to doses of  $5 \times 10^3$  Gy. Above this, the dose response decreased, but remained useful up to  $2 \times 10^4$  Gy. This decrease was due to radiation induced changes in the transparency of the optical fiber, rather than in the detector element itself. The variation in the dose reproducibility was found to be  $<1\%$ . The dose-response was found to be linear to within 1% from 0.01 Gy to 10 Gy, at dose-rates in the range of 1-5 Gy/min. The detector response was found to be independent of energy from 1.25 MeV to 15 MV. The measured depth dose response agreed well with corresponding ionization chamber measurements and cross-field dose profile measurements agreed well with corrected film measurements. These dosimeter systems offer several advantages over other dosimeter types, including: small size, high sensitivity, linearity of dose-response, insensitivity to electromagnetic interference, and cost effectiveness.

An evaluation of the dosimetric characteristics of these systems in fiber and sheet form, and their suitability for patient dose monitoring during radiotherapy treatments will be reported. Use of this system for on line dose rate monitoring, including the background Cerenkov radiation contamination, will be addressed.

**Optical Fiber Dosimetry**

By

Alan L. Huston

Optical Sciences Division, Code 5611

Naval Research Laboratory

Washington, D.C. 20375 USA

Phone: (202) 767-9470

FAX: (202) 404-8114

e-mail: [alan.huston@nrl.navy.mil](mailto:alan.huston@nrl.navy.mil)

**Abstract**

The development of optical fiber dosimetry for monitoring ionizing radiation will be reviewed. Methods based on photo-darkening, scintillation and optically stimulated luminescence will be described. Applications include environmental sensing and real-time in vivo radiotherapy monitoring.

## Optical Fiber Dosimetry

By

Alan L. Huston

Optical Sciences Division, Code 5611

Naval Research Laboratory

Washington, D.C. 20375 USA

Phone: (202) 767-9470

FAX: (202) 404-8114

e-mail: [alan.huston@nrl.navy.mil](mailto:alan.huston@nrl.navy.mil)

### Summary

The effect of ionizing radiation on optical fibers has been studied for many years. A great deal of effort was expended to develop an understanding of the mechanisms associated with radiation damage in glasses with the hope of developing radiation hardened materials for optical fiber communications and sensors. It was recognized very early that the radiation-induced absorption and/or scintillation characteristics of optical fibers could be used to quantify radiation exposure. The knowledge developed concerning the chemistry and physics of radiation damage permitted the development of glass compositions that are particularly sensitive to radiation exposure. Glass compositions used for radiation dosimetry via induced absorption include silica glasses doped with one or more of the following elements: Ge, P, rare-earth and transition metal ions. The mechanism associated with induced absorption generally involves breaking of Si-O bonds and the formation of new bonds with dopant ions, changes in the coordination sphere surrounding an ion or ionization and charge trapping in the glass matrix. Optical absorption measurements have limited dynamic range and often require lengths of several meters to kilometers of fiber, depending on the radiation levels, to provide sufficient signal to noise. Depending on the glass composition, the darkening can be permanent or semi-permanent so that the fiber can be used to integrate the dose in a low dose rate environment for an extended period of time.

Radiation-induced scintillation provides a sensitive alternative to absorption methods for radiation dosimetry. Fiber scintillation detectors have been manufactured using a variety of luminescent glasses and dye-doped plastic fibers. When these materials are used, the luminescence signal is proportional to the dose rate. In order to determine the total dose, the signal must be monitored continuously for a specific period of time and then integrated. In some cases, radiation exposure causes the formation of luminescent defect centers in the fiber that can be used to determine the absorbed dose. A calibrated optical source is used to excite the luminescent centers and the intensity of the signal provides a measure of the absorbed dose.

Radiation-induced defects in glasses can often be thermally annealed to restore the glass to its pre-irradiated condition. In some materials, heating the glass causes luminescent recombination of electron-hole pairs that were created by exposure to ionizing radiation. This thermoluminescence (TL) signal can be used to determine the absorbed dose. Radiation sensors have been fabricated by attaching a short piece of TL material to the end of an optical fiber, and coating the tip with a material that absorbs laser light. The absorbed light rapidly heats the tip of the fiber to several hundred degrees resulting in a TL signal that is proportional to the absorbed dose. The required heating of the tip of the fiber is often impractical.

An alternative to TL is optically stimulated luminescence (OSL). OSL is similar to TL except that the luminescent recombination of the trapped electron-hole pairs is initiated using light rather than heat. Several types of OSL-based optical fiber dosimeters have been demonstrated. One approach uses a crystalline material such as SrS, doped with a mixture of Eu and Sm, that is attached to the end of the fiber. Following exposure to a radiation source, the OSL material is illuminated with near infrared light to stimulate luminescent recombination. The OSL signal generally appears at a shorter wavelength than the stimulation light.

Several new OSL glass materials have been developed recently at the U.S. Naval Research Laboratory. One particularly promising material is a copper-doped fused quartz glass that can be fabricated into fibers and used for a variety of radiation sensing applications. An optical fiber dosimeter has been developed for in vivo monitoring of patients during radiotherapy procedures consisting of a 1-mm long, 0.4-mm diameter piece of copper-doped fused quartz that is fusion spliced to a 1 m long commercial optical fiber. This fiber can be placed directly at the site of a tumor and used to monitor the therapeutic radiation dose in real-time. The optical readout can be remotely located in the control room and connected to the dosimeter via a 10-m patch cable. The readout unit consists of a 795-nm diode laser, a photon counting module and a bifurcated fiber bundle to direct the stimulation and signal light. Optical filters are used to isolate the 795-nm stimulation light from the 500-nm signal.

**Acknowledgment:** This work was supported by the U.S. Army Medical Research and Materiel Command, Prostate Cancer Research Program

## DOSIMETRIC CHARACTERISTICS OF AN OPTICALLY STIMULATED LUMINESCENT (OSL) FIBEROPTIC DOSIMETRY SYSTEM

Miller, R.W.<sup>1</sup>, Huston, A.<sup>2</sup>, Ning, H.<sup>1</sup>, Worlely, S.<sup>1</sup>, Bevels, T.<sup>1</sup>, Justus, B.<sup>2</sup>, and Altemus, R.<sup>1</sup>

<sup>1</sup>Radiation Oncology Branch, COP, DCT, NCI, NIH, Bethesda, MD 20892

<sup>2</sup>Optical Sciences Division, Naval Research Laboratory, Washington, DC 20375

**Purpose:** A new dosimetry system has been developed using Optically Stimulated Luminescent (OSL) phosphors. These phosphors are activated, metal ion doped glasses that have excellent optical transparency and can be fabricated in sheets, rods, tubes or fibers. The effective atomic number of the OSL glass is 10.8 and is suitably close to tissue equivalence value of 7.4. In addition, the density of the glass,  $2.2 \text{ g/cm}^3$ , is closer to the density of water than semiconductor-based radiation dosimeters typically used for patient dose verification during radiotherapy. These phosphors offer several potential advantages over other dosimeter types, such as TLDs, diodes and small ion chambers, including: small size, high sensitivity, linearity of dose-response and insensitivity to electromagnetic interference. They can measure instantaneous dose-rate as well as cumulative dose. An evaluation of the dosimetric characteristics of this detector system was performed in order to determine its suitability both for patient dose monitoring during radiotherapy and as a potential field detector for the characterization of small radiation fields.

**Materials and Methods:** The basic schematic of the fiberoptic OSL dosimetry system is illustrated in Figure 1.

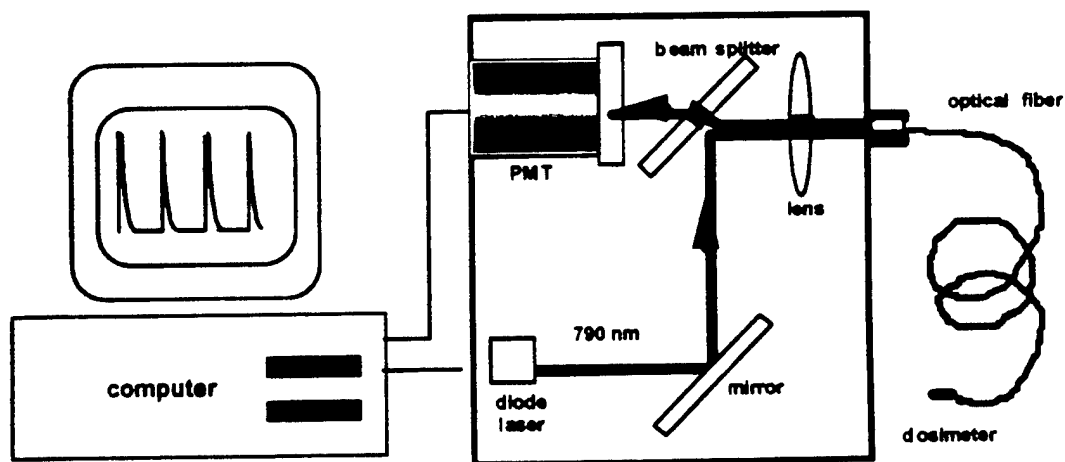

Figure 1. Single channel OSL dosimetry system schematic

The fiberoptic-coupled dosimeter elements were constructed using an OSL glass material that contained  $\text{Cu}^{1+}$  ions in a fused quartz glass. A fused quartz rod, 20 mm in diameter and 1 meter

in length was doped with  $\text{Cu}^{+1}$  ions by thermal diffusion of the Cu ions at temperatures in excess of  $1100^{\circ}\text{C}$ . This rod was then drawn into a 400 $\mu\text{m}$  diameter fiber. Approximately 0.1 cm lengths of the OSL glass fiber were joined to a 10 meter long commercial multi-mode optical fiber by fusion splicing. The dosimeters were evaluated using  $^{60}\text{Co}$   $\gamma$  rays, 6 MV and 15 MV x-rays. Radiation longevity, minimum detectable dose and dose-rate, linearity of dose-response as a function of total dose and dose-rate, energy dependence, reproducibility, calibration stability, depth dose response and small field dose profile accuracy were all studied.

**Results and Discussion:** Studies indicated that the detector response was unaffected up to total dose of 500,000 cGy. Above this, the dose response decreased, but remained useful up to 2,000,000 cGy. This decrease was due to radiation induced changes in the optical fiber, rather than in the detector element. The variation in the dose reproducibility was found to be  $<1\%$ . The dose-response was found to be linear to within 1% from 1 cGy to 1000 cGy, at dose-rates in the range of 100-500 cGy/min. The detector response was found to be independent of energy from 1.25 MeV to 15 MV. The measured depth dose response agreed well with corresponding ionization chamber measurements and cross-field dose profile measurements agreed well with corrected film measurements.

**Conclusions:** The OSL fiberoptic dosimeter system is viable clinically. It will prove especially useful for external beam surface dose measurements as well as for brachytherapy verification and could also be used for dose quantification in intravascular brachytherapy. A multi-fiber version is under development to permit several separate anatomic sites to be monitored simultaneously.

**Key Words:** Radiation detection, Patient monitoring, Absorbed dose measurement



US006087666A

# United States Patent [19]

[11] Patent Number: **6,087,666**

Huston et al.

[45] Date of Patent: **\*Jul. 11, 2000**

## [54] OPTICALLY STIMULATED LUMINESCENT FIBER OPTIC RADIATION DOSIMETER

[75] Inventors: **Alan L. Huston; Brian L. Justus**, both of Springfield, Va.

[73] Assignee: **The United States of America as represented by the Secretary of the Navy**, Washington, D.C.

[\*] Notice: This patent is subject to a terminal disclaimer.

[21] Appl. No.: **09/025,033**

[22] Filed: **Feb. 18, 1998**

[51] Int. Cl.<sup>7</sup> ..... **G01T 1/06; G01T 1/10**

[52] U.S. Cl. .... **250/484.5; 250/484.4; 250/484.2; 250/361 R**

[58] Field of Search ..... 250/361 R, 362, 250/370.07, 370.11, 484.2, 484.4, 484.3, 484.5, 458.1, 459.1

### [56] References Cited

#### U.S. PATENT DOCUMENTS

4,999,504	3/1991	Braunlich et al. . . . .	
5,030,834	7/1991	Lindmayer et al. . . . .	
5,091,653	2/1992	Creager et al. . . . .	250/484.5
5,585,640	12/1996	Huston et al. . . . .	
5,606,163	2/1997	Huston et al. . . . .	
5,656,815	8/1997	Huston et al. . . . .	
5,811,822	9/1998	Huston et al. . . . .	250/484.4

*Primary Examiner*—Constantine Hannaher  
*Assistant Examiner*—Albert Gagliardi  
*Attorney, Agent, or Firm*—Barry A. Edelberg; Ralph T. Webb

### [57] ABSTRACT

An optically-stimulated luminescent radiation dosimeter system for the remote monitoring of radiation sources is disclosed. The system includes a radiation-sensitive optically-stimulated dosimeter which utilizes a new, doped glass material disposed at a remote location for storing energy from ionizing radiation when exposed thereto and for releasing the stored energy in the form of optically-stimulated luminescent light at a first wavelength when stimulated by exposure to light energy at a stimulating second wavelength. The system further includes: an optical source for providing stimulating light energy at the stimulating second wavelength; a photodetector for measuring optically-stimulated luminescent emissions; and an optical fiber for passing the stimulating light energy from the optical source to the optically-stimulated luminescent dosimeter to stimulate the optically-stimulated luminescent dosimeter to produce optically-stimulated luminescence light from stored energy and for passing the optically-stimulated luminescence light to the optically-stimulated luminescent detector to enable the photodetector to measure any optically-stimulated luminescent emissions occurring when the optically-stimulated luminescent dosimeter is excited by the light energy at the stimulating second wavelength. Also, the dosimeter can be used for real-time monitoring by detecting the scintillations emitted by the doped glass material upon exposure to ionizing radiation.

**20 Claims, 4 Drawing Sheets**

