

AD_____

Award Number: DAMD17-00-1-0333

TITLE: In Vivo Structure-Function Studies on the Precise Role
of ErbB Signaling in Mammary Gland Development

PRINCIPAL INVESTIGATOR: Richard Chan

CONTRACTING ORGANIZATION: McMaster University
Hamilton, Ontario, Canada, L8S 4K1

REPORT DATE: October 2001

TYPE OF REPORT: Annual Summary

PREPARED FOR: U.S. Army Medical Research and Materiel Command
Fort Detrick, Maryland 21702-5012

DISTRIBUTION STATEMENT: Approved for Public Release;
Distribution Unlimited

The views, opinions and/or findings contained in this report are those of the author(s) and should not be construed as an official Department of the Army position, policy or decision unless so designated by other documentation.

20020124 229

REPORT DOCUMENTATION PAGEForm Approved
OMB No. 074-0188

Public reporting burden for this collection of information is estimated to average 1 hour per response, including the time for reviewing instructions, searching existing data sources, gathering and maintaining the data needed, and completing and reviewing this collection of information. Send comments regarding this burden estimate or any other aspect of this collection of information, including suggestions for reducing this burden to Washington Headquarters Services, Directorate for Information Operations and Reports, 1215 Jefferson Davis Highway, Suite 1204, Arlington, VA 22202-4302, and to the Office of Management and Budget, Paperwork Reduction Project (0704-0188), Washington, DC 20503

1. AGENCY USE ONLY (Leave blank)		2. REPORT DATE October 2001	3. REPORT TYPE AND DATES COVERED Annual Summary (1 Sep 00 - 1 Sep 01)	
4. TITLE AND SUBTITLE In Vivo Structure-Function Studies on the Precise Role of ErbB Signaling in Mammary Gland Development			5. FUNDING NUMBERS DAMD17-00-1-0333	
6. AUTHOR(S) Richard Chan				
7. PERFORMING ORGANIZATION NAME(S) AND ADDRESS(ES) McMaster University Hamilton, Ontario, Canada , L8S 4K1 E-Mail:			8. PERFORMING ORGANIZATION REPORT NUMBER	
9. SPONSORING / MONITORING AGENCY NAME(S) AND ADDRESS(ES) U.S. Army Medical Research and Materiel Command Fort Detrick, Maryland 21702-5012			10. SPONSORING / MONITORING AGENCY REPORT NUMBER	
11. SUPPLEMENTARY NOTES Report contains color				
12a. DISTRIBUTION / AVAILABILITY STATEMENT Approved for Public Release; Distribution Unlimited				12b. DISTRIBUTION CODE
13. ABSTRACT (Maximum 200 Words) The ErbB-2 receptor tyrosine kinase is an important member for the Epidermal Growth Factor Receptor family. It has both a potent tyrosine kinase domain that can transphosphorylate its dimerization partner or other substrates and it has a carboxy-terminal domain containing several tyrosine autophosphorylation sites. We are interested in studying the role and significance of these two domains using a physiologically relevant in vivo system. We have used a targeted knock-in strategy to generate mice expressing these mutant ErbB-2 receptors under the control of the endogenous erbB-2 promoter. The ErbB-2 kinase domain is absolutely essential for the receptors function since impairment of its activity resulted in a null phenotype. We have also generated mice expressing the ErbB-2 receptor where the five tyrosine phosphorylation sites have been mutated to phenylalanine residues (Neu-NYPD). Characterization of these mice will begin as we expand the colony.				
14. SUBJECT TERMS Epidermal Growth Factor Receptor; ErbB-2; Tyrosine Kinase; Tyrosine Phosphorylation; Targeted Knock-in			15. NUMBER OF PAGES 41	
			16. PRICE CODE	
17. SECURITY CLASSIFICATION OF REPORT Unclassified	18. SECURITY CLASSIFICATION OF THIS PAGE Unclassified	19. SECURITY CLASSIFICATION OF ABSTRACT Unclassified	20. LIMITATION OF ABSTRACT Unlimited	

Table of Contents

Cover.....	1
SF 298.....	2
Table of Contents.....	3
Introduction.....	4
Body.....	5-6
Key Research Accomplishments.....	7
Reportable Outcomes.....	7
Conclusions.....	8
References.....	9-10
Appendices.....	Figure 1 11 Figure 2 12 Manuscript ... x1-29

Introduction

The ErbB-2/Neu receptor tyrosine kinase is a member of the Epidermal Growth Factor Receptor (EGFR) family that also includes the EGFR/ErbB-1, ErbB-3 and ErbB-4 (Yarden et al., 1988). The potential for different combinations of homodimers and heterodimers contribute to this family's complex array of signaling potential (Pinkas-Kramarski et al., 1996 and 1998). Although ErbB-2 is an orphan receptor without a ligand, it is thought to be the key member of this family particularly because of its potent tyrosine kinase activity. It is also considered the preferred heterodimerization partner for the other ErbB receptors forming stable and strong signaling complexes (Graus-Porta et al., 1997).

The carboxy-terminus of the ErbB-2 receptor has been recently characterized (Dankort et al., 1997). It contains five tyrosine residues which can become phosphorylated upon receptor activation and serve as docking sites for intracellular signaling molecules. Various ErbB-2 receptors harboring mutations at different tyrosine autophosphorylation sites have been tested using *in vitro* transformations assays to examine their roles in ErbB-2 mediated transformation (Dankort et al., 1997; Qian et al., 1994). However, one of the limitations of this assay is that it is a single end-point readout and there may be more underlying complexities not revealed by the assay. To address this shortcoming, my research project is aimed at studying the functional roles of ErbB-2 and its different components by expressing ErbB-2 mutants in an *in vivo* mammalian system.

Body

We have designed a strategy to express mutant ErbB-2 receptors harboring alterations either in the kinase domain or in the tyrosine phosphorylation sites in the C-terminus. In this targeted knock-in strategy, an *erbB-2/neu* cDNA is inserted in-frame into the endogenous mouse *erbB-2* locus such that the cDNA is now expressed under the control of the endogenous *erbB-2* promoter (figure 1). The cDNA is targeted to the *erbB-2* locus by homologous recombination. It is a generic *erbB-2* knock-in vector such that different mutant *erbB-2* cDNAs can be targeted simply by switching the cDNA cassettes. This knock-in construct was recently completed and we have sequenced through the important regions to confirm that the assembly of the targeting vector is correct.

As mentioned above, the kinase activity of ErbB-2 is thought to be a critical component of the EGFR family's signaling potential. We have addressed the significance of this kinase activity by generating mice expressing a kinase-dead ErbB-2 receptor. We have completed this study and have submitted a manuscript entitled "The catalytic activity of the ErbB-2 receptor tyrosine kinase is essential for embryonic development" to Molecular and Cellular Biology (see appendix 3). Briefly, the kinase-dead ErbB-2 receptor acts as a functionally null receptor *in vivo* resulting in an identical phenotype as the *erbB-2* null mice. These mice die at midgestation due to aberrant heart development and display abnormal peripheral nervous system development (Lee et al., 1995; Britsch et al., 1998). Thus, the kinase activity of ErbB-2 is absolutely required for ErbB-mediated signaling. Conversely, the phosphorylation sites in the kinase-dead receptor are still present and may potentially become transphosphorylated by other ErbB receptors to initiate its interaction with downstream signaling molecules. However, our

results suggest that the presence of just the tyrosine phosphorylation sites in the C-terminus is not sufficient or necessary for ErbB-2 signal transduction. We are currently in the process of investigating this further by generating the appropriate knock-in model (see below).

To test the significance and the role of the tyrosine phosphorylation sites *in vivo*, we have inserted the cDNA encoding for Neu-NYPD (Neu tYrosine Phosphorylation Deficient) into the knock-in construct. The NYPD mutant is an ErbB-2 receptor where all five of the tyrosine phosphorylation sites have been mutated to phenylalanine residues. This mutant is greatly impaired with respect to *in vitro* transformation of fibroblast cells. This construct was electroporated into R1 ES cells and individual clones were selected and screened for targeted recombination by Southern Blot analysis. Four independent positive ES clones were identified (figure 2). ES clones #512 and #505 were subsequently used in blastocyst injection experiments and chimeric mice were generated with successful germline transmission of the knock-in allele. We are currently expanding the Neu-NYPD mouse colony and have yet to begin to fully characterize the implications of expressing this mutant receptor.

We have also electroporated the wild-type *neu* cDNA into ES cells and we are currently screening ES clones for successful targeted recombination. This will serve as the important control for the *in vivo* studies using the knock-in approach. One problem that we have encountered is that our targeting efficiency with this constructs is much less than we anticipated. Thus, we have had to repeat electroporations a few times and have had to take more time to screen many more ES colonies. We are currently modifying the conditions in an attempt to improve the chances of isolating targeted clones.

Key Research Accomplishments:

- Generic *erbB-2* knock-in targeting construct completed
- Completed analysis of mice expressing a kinase-dead ErbB-2 receptor.
- Manuscript submitted.

- Targeting construct containing the *neu-NYPD* cDNA completed
- Electroporated into ES cells; positive clones identified; chimeric mice generated with successful germline transmission; currently expanding the colony.

- Targeting construct expressing the wild-type *neu* cDNA completed
- Electroporated into ES cells and first round of screening completed.
- No positive clones yet.

- Targeting construct expressing other mutant *neu* cDNA completed.
- Further analysis pending outcome of the NYPD experiments.

Reportable Outcomes:

- Manuscript submitted to *Molecular and Cellular Biology*: "*The catalytic activity of the ErbB-2 receptor tyrosine kinase is essential for embryonic development*"

Conclusions

The results with the analysis of mice expressing a kinase-dead ErbB-2 receptor suggest implications for therapeutic targets with respect to efficacy and potency issues. We concluded that the kinase activity of ErbB-2 is essential for its ability to signal and that its kinase activity cannot be compensated for by other members of the EGFR family. Thus, the kinase domain of ErbB-2 may present itself as an ideal therapeutic target because of its essential requirement for the receptors activity. Although this may appear to be a potent and effective means of inhibiting ErbB-2 mediated pathogenesis, at the same time, it may result in many side effects and drawbacks because other ErbB receptors may also depend on this kinase activity for their function. Thus, a kinase inhibitor specific for ErbB-2 may still have widespread implications.

We also did not observe any indication in our analyses that the kinase-dead ErbB-2 receptor was functioning in a transdominant manner as previously described *in vitro* (Qian et al, 1994). This brings to question the idea of expressing a kinase-dead ErbB-2 receptor, via adenovirus or other genetherapy techniques, to suppress ErbB-2 positive tumour growth and progression.

Up to this point most of the work was to make the targeting constructs, screening cohorts of ES colonies and making transgenic animals by blastocyst injection of the ES cells. There is little in terms of conclusions or implications/importance until we complete the characterization of the animals. More valid and relevant conclusions can be made once we begin to get some feedback from our analyses. The implications may be significant pending a comprehensive comparison of the kinase-dead versus NYPD mutants.

References

1. **Britsch, S., L. Li, S. Kirchhoff, F. Theuring, V. Brinkmann, C. Birchmeier, and D. Riethmacher.** 1998. The ErbB2 and ErbB3 receptors and their ligand, neuregulin-1, are essential for development of the sympathetic nervous system. *Genes Dev* **12**:1825-1836.
2. **Dankort, D.L., Wang, Z., Blackmore, V., Moran, M.F., and Muller, W.J.** 1997. Distinct tyrosine autophosphorylation sites negatively and positively modulate Neu-mediated transformation. *Mol. Cell. Biol.* **17**: 5410-5425.
3. **Graus-Porta, D., R.R. Beerli, J.M. Daly, and N.E. Hynes.** 1997. ErbB-2, the preferred heterodimerization partner of all ErbB receptors, is a mediator of lateral signaling. *EMBO J* **16**:1647-1655.
4. **Lee, K.F., H. Simon, H. Chen, B. Bates, M.C. Hung, and C. Hauser.** 1995. Requirement for neuregulin receptor erbB2 in neural and cardiac development [see
5. **Pinkas-Kramarski, R., M. Shelly, B.C. Guarino, L.M. Wang, L. Lyass, I. Alroy, M. Alimandi, A. Kuo, J.D. Moyer, S. Lavi, M. Eisenstein, B.J. Ratzkin, R. Seger, S.S. Bacus, J.H. Pierce, G.C. Andrews, Y. Yarden, and M. Alamandi.** 1998. ErbB tyrosine kinases and the two neuregulin families constitute a ligand-receptor network [published erratum appears in *Mol Cell Biol* 1998 Dec;18(12):7602]. *Mol Cell Biol* **18**:6090-6101.

6. **Pinkas-Kramarski, R., L. Soussan, H. Waterman, G. Levkowitz, I. Alroy, L. Klapper, S. Lavi, R. Seger, B.J. Ratzkin, M. Sela, and Y. Yarden.** 1996. Diversification of Neu differentiation factor and epidermal growth factor signaling by combinatorial receptor interactions. *EMBO J* **15**:2452-2467.
7. **Qian, X., C.M. LeVea, J.K. Freeman, W.C. Dougall, and M.I. Greene.** 1994. Heterodimerization of epidermal growth factor receptor and wild-type or kinase-deficient Neu: a mechanism of interreceptor kinase activation and
8. **Yarden, Y. and A. Ullrich.** 1988. Growth factor receptor tyrosine kinases. *Annu Rev Biochem* **57**:443-478.

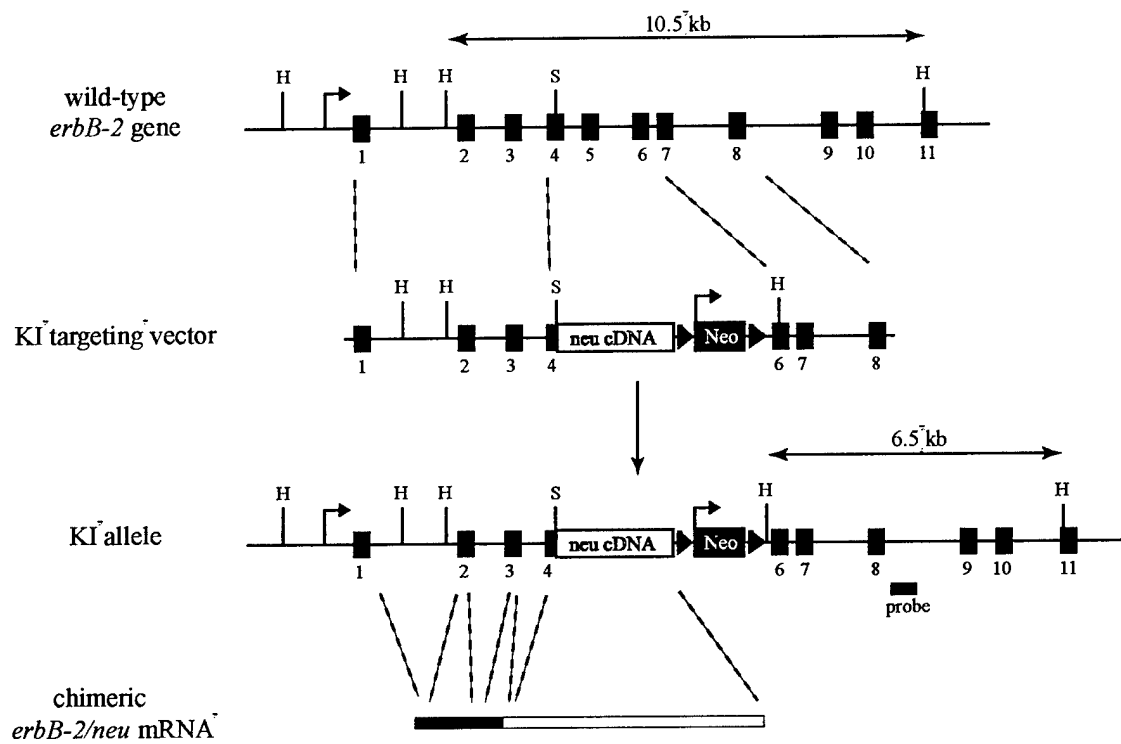

Figure 1. Targeted knock-in strategy to express mutant *erbB-2/neu* cDNA under the control of the endogenous promoter. The knock-in vector is targeted to the *erbB-2* locus by homologous 5' and 3' flanking arms. Following homologous recombination, the cDNA is expressed in place of the genomic *erbB-2* allele.

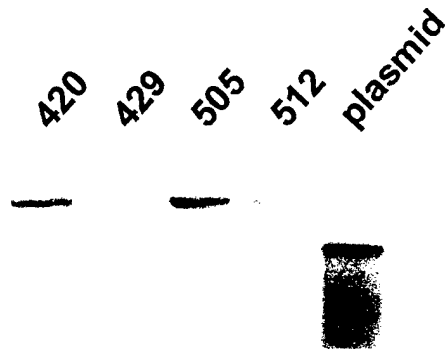

Figure 2. Southern Blot analysis of ES clones for Neu-NYPD using an external probe. This is a repeat blot to confirm results from an initial screen of ES colonies. The top band is 10.5kb and represents the wild-type allele. The lower band is 6.5kb and represents the targeted knock-in allele. Clones #505 and 512 were used in blastocyst injection experiments to generate chimeric mice.

The catalytic activity of the ErbB-2 receptor tyrosine kinase is essential for embryonic development.

Richard Chan¹, William R. Hardy¹, Michael A. Laing¹, Sarah E. Hardy¹, and William J. Muller^{1,2,3,*}

Departments of Biology¹, Biochemistry² and Pathology and Molecular Medicine³,
McMaster University, 1280 Main Street West, Hamilton, Ontario, Canada, L8S 4K1.

*Corresponding author:

William J. Muller

McMaster University, Life Sciences Building 327

1280 Main Street West, Hamilton, Ontario, Canada, L8S 4K1

Phone: (905) 525-9140 ext. 27306

Fax: (905) 521-2955

E-mail: mullerw@mcmaster.ca

Running Title: A kinase-dead ErbB-2 receptor is functionally null.

Keywords: ErbB-2, receptor tyrosine kinase, kinase-dead

Abbreviations: EGFR, epidermal growth factor receptor; KD, kinase-dead; KI, knock-in;

RTK, receptor tyrosine kinase

Abstract

Activation of the epidermal growth factor receptor (EGFR) family is thought to play a critical role in both embryogenesis and oncogenesis. The diverse biological activities of the EGFR family are achieved through various ligand-receptor and receptor-receptor interactions. One receptor that has emerged to play a central role in this signaling network is ErbB-2/Neu and is considered to be the preferred heterodimerization partner for other members of the EGFR family. To assess the importance of the catalytic activity of ErbB-2 in embryonic development, we have generated mice expressing a kinase-dead *erbB-2* cDNA under the transcriptional control of the endogenous promoter. Here, we show that mice homozygous for the kinase-dead *erbB-2* allele are embryonic lethal and display the same spectrum of embryonic defects seen in *erbB-2* knockout mutants. These observations suggest that the catalytic activity of ErbB-2 is essential for normal embryonic development.

Introduction

The EGFR family of growth factor receptor tyrosine kinases (RTK) including ErbB-1/EGFR, ErbB-2/Neu, ErbB-3 and ErbB-4 have been implicated in breast cancer as well as several other human cancers (2). Recently, gene targeting studies have demonstrated specific roles for each of the EGFR family members in normal mammalian development. For example, *erbB-2* (12) and *erbB-4* (6) knockout mice die at midgestation due to deficient cardiac function associated with a lack of myocardial ventricular trabeculation and display abnormal development of the peripheral nervous system. Cardiac rescue of the defects seen in *erbB-2* null mice revealed additional roles for ErbB-2 at the developing neuromuscular junction (13;17). ErbB-3 mutant mice have less severe defects in the heart and consequently are able to survive several days later through embryogenesis. However, sensory and motor neurons in these animals show signs of degeneration due to a lack of proper Schwann cell development (1;22).

Although the structures of the EGFR family receptors have been described in detail, their individual role and contribution to these developmental processes remains to be investigated. To achieve the observed diversity in signaling potential, a coordinate array of ligand-receptor and receptor-receptor interactions are possible. Following activation of the various EGFR family members with one of several EGF family ligands, both homodimeric and/or heterodimeric combinations of receptors are induced and their intrinsic catalytic tyrosine kinase activity is stimulated (30). Upon receptor dimerization, specific tyrosine residues residing in the terminal tail of the receptor dimer become phosphorylated and serve as important potential binding sites for various intracellular signaling proteins.

Although activated ErbB receptors may partake in any particular combination of homodimerization or heterodimerization complexes, it is important to note that a hierarchical order of preference, stability and signaling potential for each receptor combination is in effect (7). In particular, there is generally a greater preference and likely an advantage for dimerization complexes to include ErbB-2 as the partner because of its potent intrinsic kinase activity. Since no identified ligand is known to bind to and activate ErbB-2 alone, it is considered to be an orphan receptor. Thus, stimulation of ErbB-2 kinase activity may be mediated through normal ligand activation of another ErbB receptor first, which subsequently engages in a specific heterodimer complex (3;18;19). In contrast, ErbB-3 which can bind to and become activated by the ligand neuregulin, is naturally kinase inactive and therefore must depend on a heterodimerization partner for phosphorylation of its tyrosine residues (8;26). Indeed, the ErbB-2:ErbB-3 complex is very stable and transmits a strong mitogenic signal (11). These observations strongly suggest that ErbB-2 plays a central role in the EGFR family signal transduction.

Although genetic ablation studies demonstrate the importance of a receptor to a biological function, it does not address precisely how and which of the individual functional domains of the receptor contributes to the phenotype. It is also unclear within this complex array of receptor dimerization whether the loss of ErbB-2 results in direct or indirect consequences of a lack of the receptor and its interactions with other proteins. To assess exactly how ErbB-2 may act as the central mediator of the EGFR family of receptors, we investigated whether the kinase activity of ErbB-2 is indeed essential for its complete biological effects. To accomplish this, we generated mice expressing a kinase-dead *erbB-2* cDNA under the transcriptional control of the endogenous *erbB-2* promoter. Mice

homozygous for the kinase-dead *erbB-2* mutation died at E10.5 due to a lack of cardiac trabeculation and displayed defects in neural development. These observations argue that the catalytic activity of ErbB-2 is absolutely required for normal embryonic development and cannot be compensated for by other members of the EGFR family.

Materials and Methods

Generation of Targeting Construct and Mutant Mice

Oligonucleotide-directed PCR mutagenesis using the following primers was employed to create the mutant (K757M) kinase-dead ErbB-2 receptor. AB11151: GGA AGT ATA CGA TCG CTA GGC; AB10015: CAC CAT GAT AGC CAC GGG GAT TTT CAC; AB 10014: C GTG GCT ATC ATG GTG TTG AGA GAA AAC; AB 11152: CGA CCT CGG TGT TCT CGG AC. The underlined nucleotides identify the substituted sequence to create the desired mutation. PCR products were subsequently sub-cloned into a wild-type *erbB-2* cDNA and then cloned into the final targeting vector. This plasmid was electroporated into R1 ES cells and G418 or Geneticin (GIBCO-BRL) resistant colonies were picked and subsequently screened by Southern Blot analysis for correctly targeted mutants. Mutant mice were generated from the positive ES cell clones by method of blastocyst injection into balb/c-derived blastocysts (10). Subsequent generations were maintained in an SV129/Balb/c background.

RNase Protection Assays

RNA was extracted and purified from individual embryos by the Guanidine Isothiocyanate-Cesium Chloride (GiT-CsCl) method as previously described (27). For

RNase protection assays, as described previously (24), 30 μ g of total RNA was used and hybridized to an anti-sense *erbB-2* riboprobe (23). The protocol was modified by lowering the overnight hybridization to 45°C and only T1 RNase (450 units) was used in the digestion reactions for 20 minutes at 37°C.

Western Blot Analysis

Fresh or flash frozen embryos were lysed in TNE lysis buffer (24). Cleared lysates were electrophoresed through SDS-polyacrylamide gels and the proteins transferred to PVDF membranes (Immobilon-P; Millipore). The membranes were blocked in 10% skim milk/TBS for 1 hour at room temperature and then incubated with the appropriate antibody. For ErbB-2 immunoblots, the membranes were incubated with anti-ErbB-2 antibodies (1:1000; AB-3, Oncogene Science) overnight at 4°C. Immunoblots for Grb2 were performed with rabbit anti-Grb2 polyclonal sera (1:2500; C-23, Santa Cruz). After the primary antibody incubations, membranes were subjected to 4 x 15 minute washes in TBS-1% Tween-20 (Bio-Rad). Subsequently, horseradish peroxidase-conjugated anti-mouse or anti-rabbit secondary antibodies (1:5000; Jackson Laboratories) were incubated with the membranes for 1 hour at room temperature then washed 2 x 15 minutes in TBS-1% Tween-20 and 2 x 15 minutes in TBS alone. Immunoblots were visualized by enhanced chemiluminescence (Amersham) as specified by the manufacturer.

Histology

Embryos from timed-matings were dissected free from the placenta and cleared of extraembryonic tissues. A small piece of the visceral yolk sac was retained and placed in

tail lysis buffer (100 mM Tris-HCl, pH 8.5; 5 mM EDTA; 0.2% SDS; 200 mM NaCl; 100 µg/µl Proteinase K), the DNA isolated and subsequently used for genotyping the embryos. Dissected embryos were quickly rinsed in ice-cold PBS and transferred directly into 4% paraformaldehyde, fixed overnight at 4°C, washed 2x in 70% ethanol and stored at 4°C in 70% ethanol. For standard hematoxylin and eosin (Fisher Scientific) staining, samples were embedded in paraffin and 8µm serial sections were cut and mounted. For whole-mount *in situ* hybridizations, embryos were fixed in 4% paraformaldehyde/0.2% glutaraldehyde (Fisher Scientific), dehydrated through a graded series of methanol/PBT (1X PBS/0.1% Tween-20, Sigma) baths and stored in 100% MeOH at -20°C until needed. Whole-mount *in situ* hybridizations were carried out as previously described (29).

In vitro transcription of *Phox2a* riboprobes

The *Phox2a* riboprobe plasmid, pKS903 SSN (25), was digested with SstII and transcribed with the T3 RNA polymerase to generate an antisense riboprobe; the sense riboprobe was generated using the same template, but linearized with HindIII and transcribed with T7 RNA polymerase. The *in vitro* transcription reactions were carried out in 20µl reaction volumes containing 14 µl dH₂O (DEPC), 2 µl 10X transcription buffer (Boehringer Mannheim), 2 µl DIG RNA Labelling Mix (Boehringer Mannheim), 1 µg of template DNA, 30 units RNAGuard (Pharmacia) and 30 units of RNA polymerase (Boehringer Mannheim or Gibco-BRL). The reactions were incubated @ 37°C for 2 hours and stopped with the addition of 20 units of DNaseI (RNase-Free, Boehringer Mannheim). The riboprobes were precipitated and resuspended in 100 µl of DEPC dH₂O (~100 ng/µl).

Results and Discussion

A kinase-dead (KD) variant of the ErbB-2/Neu receptor was created by oligonucleotide-directed PCR mutagenesis to generate a point mutation affecting lysine residue 757. This K757M alteration ablates the conserved ATP-binding lysine residue in the tyrosine kinase domain resulting in its inability to phosphorylate its substrates (20;21;28). We have confirmed that disruption of this key amino acid results in ablation of ErbB-2 associated kinase activity and also inactivates the potent transforming activity of an oncogenic *erbB-2* mutant (data not shown). To determine the functional importance of the ErbB-2 kinase activity *in vivo*, we generated a targeting vector in which the first coding exon of the endogenous *erbB-2* gene was replaced with either a wild-type *erbB-2* cDNA (*erbB-2* knock-in or KI) (Figure 1A) or a cDNA harboring the K747M mutation (*erbB-2* KD) (Figure 1B). To facilitate recovery of targeted recombination events, a PGK-Neo expression cassette was inserted downstream of the inserted cDNA. The constructs were electroporated into R1 ES cells and independent clonal lines were isolated and subjected to Southern blot analyses with an appropriate external probe to identify successful targeting events (Figure 1).

After microinjection of several independently targeted ES cell lines into donor blastocysts, chimeric mice were obtained and bred to identify those that transmitted the mutant alleles through the germline. *ErbB-2^{w/KI}* and *erbB-2^{w/KD}* mice appeared normal and were fertile. *ErbB-2^{KI/KI}* mice were also viable and were generated at the expected Mendelian ratios (data not shown). Thus, in contrast to the generation of *erbB-2^{-/-}* mice where exon 1 was replaced by a PGK-neomycin cassette (12), replacement of the first coding exon of *erbB-2* with a wild-type *erbB-2* cDNA rescued the embryonic lethality

associated with disruption and inactivation of the *erbB-2* gene. Interestingly, no viable *erbB-2*^{KD/KD} mutant mice were observed in the litters generated from heterozygous matings that were subsequently genotyped at 3-weeks of age (Figure 2A).

Since *erbB-2*^{-/-} embryos died at midgestation due to defects in heart development (12), we assessed whether we could detect viable embryos at E10.5 for our kinase-dead mutants. To accomplish this, timed matings between heterozygous animals were set up and embryos were dissected from the uterus and observed. Embryo genotypes were determined by analysis of DNA isolated from their respective visceral yolk sacs. At E10.5 each possible genotype was present at the expected Mendelian frequencies (Figure 2C) and all embryos were viable, possessed a heartbeat and appeared normal in size. However, in mutant embryos their hearts were slightly enlarged and had irregular heartbeats. Further observations at E11.5-E13.5 (Figure 2B) revealed that homozygous mutant *erbB-2*^{KD/KD} embryos, although present at the expected frequency, had no heartbeat and showed signs of resorption such as arrested growth, pale color, and soft tissue. Thus, consistent with the embryonic lethality of *erbB-2*^{-/-} mutants, these observations confirmed that mutant embryos expressing the kinase-dead ErbB-2 receptor were dying *in utero* at midgestation between E10.5 and E11.5.

To investigate the cause of embryonic lethality, we performed histological analyses of E10.5 embryos. Both *erbB-2*^{KI/KI} (Figure 3A) and *erbB-2*^{wt/KD} (Figure 3B) knock-in embryos were completely normal in their development of the heart trabeculae. In contrast, *erbB-2*^{KD/KD} mutant embryos clearly lacked development of ventricular trabeculae (Figure 3C) that likely resulted in the observed reduction of embryonic blood flow. These results are strikingly consistent with the defects previously identified in *erbB-2*^{-/-} embryos as well as

in *neuregulin*^{-/-} and *erbB-4*^{-/-} embryos (6;12;15). Thus, the cardiac defects seen in the kinase-dead mutants were directly attributable to a loss of ErbB-2's enzymatic tyrosine kinase activity.

We also examined whether the same peripheral nervous system abnormalities seen in *erbB-2*^{-/-} mutants were also similarly affected by expression of the kinase-dead mutation. One important marker for peripheral neural tissues is the Phox-2a transcription factor (16). To explore whether neural development was perturbed in the KD mice, embryos derived from E10.5 and E11.5 were subjected to wholemount *in situ* analyses using an anti-sense Phox2a riboprobe (Figure 4). In both *erbB-2*^{wt/wt} (Figures 4A & B) and *erbB-2*^{wt/KD} (Figures 4C & D) embryos, the sympathetic chain developed normally. However, in the E10.5/11 *erbB-2*^{KD/KD} homozygous embryos, only a weak Phox2a signal could be detected in the rostral-most regions of the sympathetic chain, a clear indication that this structure had either failed to initiate development or was incapable of developing in the kinase-dead genetic background (Figures 4E & F). Analyses of Phox2a expression in *erbB-2*^{KD/KD} (Figure 4E) and *erbB-2*^{KI/KI} (Figure 4G) embryos revealed that the sympathetic chain appeared to be absent at E10/10.5 when compared to age-matched wild-type and heterozygous embryos (compare Figure 4G with Figure 4A & C). However, by E10.5/11 a lengthy sympathetic chain had developed in the *erbB-2*^{KI/KI} homozygotes (Figure 4H) but remained completely absent in the *erbB-2*^{KD/KD} embryos (Figure 4F). These observations indicate that the catalytic activity of ErbB-2 is also essential for normal development of the primary sympathetic chain ganglia.

To confirm that these knock-in alleles expressed ErbB-2, we performed Western immunoblot (Figure 5A) and Ribonuclease (RNase) protection (Figure 5B) analyses. As

shown in Figure 5B, the wild-type *erbB-2* KI allele and the kinase-dead allele expressed similar levels of *erbB-2* transcripts. Similarly, immunoblot detection for ErbB-2 also revealed comparable protein levels between the two knock-in mutants at E10.5 (Figure 5A). The slightly lower levels of ErbB-2 seen in the *erbB-2*^{KD/KD} embryos relative to *erbB-2*^{KI/KI} embryos is likely due to and consistent with the loss of tissue structures in the kinase-dead mutants (Figures 2 and 3) that would normally express significant levels of ErbB-2. Interestingly, both the *erbB-2*^{KI/KI} and the *erbB-2*^{KD/KD} knock-in embryos expressed only 10-15% of the expected ErbB-2 protein as detected in *erbB-2*^{wl/wl} embryos (Figure 5A, compare lanes 1, 2 to 3-6) despite expressing comparable levels of *erbB-2* transcripts (Figure 5B) which may reflect a requirement for splicing events for efficient transport and translation of the mRNA. In this regard it should be noted that embryos expressing both copies of the wild-type knock-in *erbB-2* allele display a 24-hour delay in development of the sympathetic chain (Figure 4) suggesting that reduced ErbB-2 levels may have a minor phenotypic consequence.

Our observations have important implications in understanding the role of *erbB-2* in promoting both normal cardiac and neural development. Previous studies have demonstrated that the integrity of ErbB-2, ErbB-4 or Neuregulin is essential for the development of the cardiac trabecular extensions. Despite the presence of a functional ErbB-4 protein that could potentially transphosphorylate ErbB-2, our results further suggest that the catalytic activity of ErbB-2 alone is required to recapitulate the necessary signal transduction pathways leading to proper trabeculation. In contrast to myocardial trabeculae formation, ErbB-2 and ErbB-3 are thought to mediate the survival of neural crest cells contributing to the development of the peripheral nervous system since similar cranial

nerve phenotypes were seen in mutant ErbB-2 and mutant ErbB-3 mice as well as in Neuregulin mutants (12;15;22). Given that ErbB-3 is kinase defective and is completely dependent on its heterodimerization partners for its activation (8), inactivation of ErbB-2 catalytic activity would be expected to have profound effects on neural development. Taken together, we can conclude that ErbB signaling is dependent on the kinase activity of ErbB-2 and that a kinase-dead ErbB-2 mutant acts essentially as a functionally null receptor.

In contrast to the embryonic lethality caused by inactivation of the catalytic activity of ErbB-2, a naturally occurring germline mutation in the kinase domain of EGFR known as Waved-2 are completely viable and only display epithelial defects such as a wavy hair phenotype (5;14). Thus, unlike ErbB-2, other EGFR family members can presumably compensate for the severe impairment in EGFR catalytic activity. The difference between these phenotypes may reflect the hierarchical importance of ErbB-2 within the EGFR family signaling network. Alternatively, the difference in the phenotype in these strains may reflect the fact that the Waved-2 mutation has not completely ablated the catalytic activity of EGFR (14) and thus retains a higher degree of biological function.

Given the dominant-negative action of the kinase-dead ErbB-2 receptor expressed *in vitro* (Qian et al., 1994a) it is surprising that mice heterozygous for the *erbB-2* KD allele failed to exhibit any obvious phenotype that might be expected of a trans-dominant inhibition of the remaining wild-type allele. One potential explanation for this observation is that the level of kinase-dead ErbB-2 is insufficient to interfere with the remaining endogenous wild-type ErbB-2 receptor. Indeed, the *erbB-2* KD allele produced only 10% of the expected ErbB-2 protein (Figure 5). To exclude this possibility, we have crossed

erbB-2 KI mice with *erbB-2* KD mice since both these knock-in alleles expressed similar levels of ErbB-2. Phenotypic analyses of these crosses demonstrated that the *erbB-2* KD allele failed to exhibit a dominant-negative effect on the remaining *erbB-2* KI allele (data not shown). Thus, like the Waved-2 EGFR kinase mutation the *erbB-2* KD allele fails to exhibit any discernable dominant-negative effect on the remaining intact ErbB-2 receptor.

Studies with other receptor tyrosine kinase (RTK) have concluded that the catalytic activity of RTK is dispensable for normal physiological function of the receptor. For example, the Flt-1 (VEGF receptor) null mutation resulted in early embryonic lethality at E8.5 with disorganized blood vessels (4). However, mice expressing a kinase-deficient Flt-1 survived and showed normal angiogenesis (9), suggesting that other components of the receptor are more important to its functional role. In contrast to these observations, we have found that the catalytic activity of ErbB-2 is essential for embryonic development. Given that ErbB-2 is the preferred heterodimerization partner for the other EGFR family members (7), the requirement for ErbB-2 catalytic function *in vivo* suggest that its catalytic activity is critical for EGFR family signaling. Future studies with these strains should allow for identification of downstream targets of ErbB-2.

Acknowledgements

We wish to thank Margaret Hibbs and Ashley Dunn for providing genomic clones; Michael Rudnicki and Christo Goridis for providing plasmids used in this study. We also thank Brian Allore and Dinsdale Gooden at MOBIX Central Facility, McMaster University, for automated DNA sequencing analysis and oligonucleotide synthesis. This work was supported by a grant awarded to W.J.M. by the Medical Research Council of Canada. W.J.M. is a recipient of a Medical Research Council of Canada scientist award and R.C. was supported by an Ontario Graduate Scholarship, a studentship from the Cancer Research Society of Canada and a U.S. Army D.O.D. studentship.

References

1. **Britsch, S., L. Li, S. Kirchhoff, F. Theuring, V. Brinkmann, C. Birchmeier, and D. Riethmacher.** 1998. The ErbB2 and ErbB3 receptors and their ligand, neuregulin-1, are essential for development of the sympathetic nervous system. *Genes Dev* **12**:1825-1836.
2. **Burden, S. and Y. Yarden.** 1997. Neuregulins and their receptors: a versatile signaling module in organogenesis and oncogenesis. *Neuron* **18**:847-855.
3. **Carraway, K.L. and L.C. Cantley.** 1994. A new acquaintance for erbB3 and erbB4: a role for receptor heterodimerization in growth signaling. *Cell* **78**:5-8.
4. **Fong, G.H., J. Rossant, M. Gertsenstein, and M.L. Breitman.** 1995. Role of the Flt-1 receptor tyrosine kinase in regulating the assembly of vascular endothelium. *Nature* **376**:66-70.
5. **Fowler, K.J., F. Walker, W. Alexander, M.L. Hibbs, E.C. Nice, R.M. Bohmer, G.B. Mann, C. Thumwood, R. Maglitta, and J.A. Danks.** 1995. A mutation in the epidermal growth factor receptor in waved-2 mice has a profound effect on receptor biochemistry that results in impaired lactation. *Proc Natl Acad Sci U S A* **92**:1465-1469.
6. **Gassmann, M., F. Casagrande, D. Orioli, H. Simon, C. Lai, R. Klein, and G. Lemke.** 1995. Aberrant neural and cardiac development in mice lacking the ErbB4 neuregulin receptor [see comments]. *Nature* **378**:390-394.

7. **Graus-Porta, D., R.R. Beerli, J.M. Daly, and N.E. Hynes.** 1997. ErbB-2, the preferred heterodimerization partner of all ErbB receptors, is a mediator of lateral signaling. *EMBO J* **16**:1647-1655.
8. **Guy, P.M., J.V. Platko, L.C. Cantley, R.A. Cerione, and K.L. Carraway.** 1994. Insect cell-expressed p180erbB3 possesses an impaired tyrosine kinase activity. *Proc Natl Acad Sci U S A* **91**:8132-8136.
9. **Hiratsuka, S., O. Minowa, J. Kuno, T. Noda, and M. Shibuya.** 1998. Flt-1 lacking the tyrosine kinase domain is sufficient for normal development and angiogenesis in mice. *Proc Natl Acad Sci U S A* **95**:9349-9354.
10. **Joyner, A.L.** 1993. *Gene Targeting - A Practical Approach.* Oxford University Press,
11. **Karunagaran, D., E. Tzahar, R.R. Beerli, X. Chen, D. Graus-Porta, B.J. Ratzkin, R. Seger, N.E. Hynes, and Y. Yarden.** 1996. ErbB-2 is a common auxiliary subunit of NDF and EGF receptors: implications for breast cancer. *EMBO J* **15**:254-264.
12. **Lee, K.F., H. Simon, H. Chen, B. Bates, M.C. Hung, and C. Hauser.** 1995. Requirement for neuregulin receptor erbB2 in neural and cardiac development [see comments]. *Nature* **378**:394-398.
13. **Lin, W., H.B. Sanchez, T. Deerinck, J.K. Morris, M. Ellisman, and K.F. Lee.** 2000. Aberrant development of motor axons and neuromuscular synapses in erbB2-deficient mice [In Process Citation]. *Proc Natl Acad Sci U S A* **97**:1299-1304.

14. **Luetteke, N.C., H.K. Phillips, T.H. Qiu, N.G. Copeland, H.S. Earp, N.A. Jenkins, and D.C. Lee.** 1994. The mouse waved-2 phenotype results from a point mutation in the EGF receptor tyrosine kinase. *Genes Dev* **8**:399-413.
15. **Meyer, D. and C. Birchmeier.** 1995. Multiple essential functions of neuregulin in development [see comments] [published erratum appears in *Nature* 1995 Dec 14;378(6558):753]. *Nature* **378**:386-390.
16. **Morin, X., H. Cremer, M.R. Hirsch, R.P. Kapur, C. Golidis, and J.F. Brunet.** 1997. Defects in sensory and autonomic ganglia and absence of locus coeruleus in mice deficient for the homeobox gene *Phox2a*. *Neuron* **18**:411-423.
17. **Morris, J.K., W. Lin, C. Hauser, Y. Marchuk, D. Getman, and K.F. Lee.** 1999. Rescue of the cardiac defect in *ErbB2* mutant mice reveals essential roles of *ErbB2* in peripheral nervous system development. *Neuron* **23**:273-283.
18. **Pinkas-Kramarski, R., M. Shelly, B.C. Guarino, L.M. Wang, L. Lyass, I. Alroy, M. Alimandi, A. Kuo, J.D. Moyer, S. Lavi, M. Eisenstein, B.J. Ratzkin, R. Seger, S.S. Bacus, J.H. Pierce, G.C. Andrews, Y. Yarden, and M. Alimandi.** 1998. *ErbB* tyrosine kinases and the two neuregulin families constitute a ligand-receptor network [published erratum appears in *Mol Cell Biol* 1998 Dec;18(12):7602]. *Mol Cell Biol* **18**:6090-6101.
19. **Pinkas-Kramarski, R., L. Soussan, H. Waterman, G. Levkowitz, I. Alroy, L. Klapper, S. Lavi, R. Seger, B.J. Ratzkin, M. Sela, and Y. Yarden.** 1996.

- Diversification of Neu differentiation factor and epidermal growth factor signaling by combinatorial receptor interactions. *EMBO J* **15**:2452-2467.
20. **Qian, X., W.C. Dougall, M.E. Hellman, and M.I. Greene.** 1994. Kinase-deficient neu proteins suppress epidermal growth factor receptor function and abolish cell transformation. *Oncogene* **9**:1507-1514.
21. **Qian, X., C.M. LeVea, J.K. Freeman, W.C. Dougall, and M.I. Greene.** 1994. Heterodimerization of epidermal growth factor receptor and wild-type or kinase-deficient Neu: a mechanism of interreceptor kinase activation and transphosphorylation. *Proc Natl Acad Sci U S A* **91**:1500-1504.
22. **Riethmacher, D., E. Sonnenberg-Riethmacher, V. Brinkmann, T. Yamaai, G.R. Lewin, and C. Birchmeier.** 1997. Severe neuropathies in mice with targeted mutations in the ErbB3 receptor. *Nature* **389**:725-730.
23. **Siegel, P.M., D.L. Dankort, W.R. Hardy, and W.J. Muller.** 1994. Novel activating mutations in the neu proto-oncogene involved in induction of mammary tumors. *Mol Cell Biol* **14**:7068-7077.
24. **Siegel, P.M., E.D. Ryan, R.D. Cardiff, and W.J. Muller.** 1999. Elevated expression of activated forms of Neu/ErbB-2 and ErbB-3 are involved in the induction of mammary tumors in transgenic mice: implications for human breast cancer. *EMBO J* **18**:2149-2164.

25. **Valarche, I., J.P., M.R. Hirsch, S. Martinez, C. Goridis, and J.F. Brunet.** 1993.
The mouse homeodomain protein Phox2 regulates Ncam promoter activity in concert with Cux/CDP and is a putative determinant of neurotransmitter phenotype. *Development* **119**:881-896.
26. **Wallasch, C., F.U. Weiss, G. Niederfellner, B. Jallal, W. Issing, and A. Ullrich.** 1995. Heregulin-dependent regulation of HER2/neu oncogenic signaling by heterodimerization with HER3. *EMBO J* **14**:4267-4275.
27. **Webster, M.A., J.N. Hutchinson, M.J. Rauh, S.K. Muthuswamy, M. Anton, C.G. Tortorice, R.D. Cardiff, F.L. Graham, J.A. Hassell, and W.J. Muller.** 1998. Requirement for both Shc and phosphatidylinositol 3' kinase signaling pathways in polyomavirus middle T-mediated mammary tumorigenesis. *Mol Cell Biol* **18**:2344-2359.
28. **Weiner, D.B., Y. Kokai, T. Wada, J.A. Cohen, W.V. Williams, and M.I. Greene.** 1989. Linkage of tyrosine kinase activity with transforming ability of the p185neu oncoprotein. *Oncogene* **4**:1175-1183.
29. **Wilkinson, D.G. and M.A. Nieto.** 1993. Detection of messenger RNA by in situ hybridization to tissue sections and whole mounts. *Methods Enzymol.* **225**:361-373.
30. **Yarden, Y. and A. Ullrich.** 1988. Growth factor receptor tyrosine kinases. *Annu Rev Biochem* **57**:443-478.

Figure 1. Targeted *erbB-2* cDNA knock-in strategy by homologous recombination

For germline expression, a targeting vector was constructed where exon 1 was replaced by either (A) a wild-type *erbB-2* cDNA or (B) a cDNA encoding the kinase-dead *erbB-2* mutation, followed by a PGK-neomycin (Neo) cassette and targeted to the endogenous *erbB-2* locus by homologous 5' and 3' flanking arms. Digestion of genomic DNA with HindIII (H) and subsequent Southern Blot analysis (inset) with an external probe, as indicated, resulted in a 7.5 kb band for the endogenous allele whereas the knock-in cDNA alleles introduced a HindIII site and resulted in a 4.0 kb band.

Figure 2. Embryonic lethality at midgestation in kinase-dead mutants

Mendelian ratios from the progeny of heterozygous matings were determined and compared with the frequency of genotypes observed. (A) No homozygous *erbB-2*^{KD/KD} mutant animals were observed at weaning age (3-weeks old). (B) Observations at E11.5-E13.5 revealed the expected number of mutant embryos however all *erbB-2*^{KD/KD} (**) embryos were being resorbed and no heartbeat was detected. (C) At E10.5, all the embryos appeared healthy and were present in proportion with Mendelian frequencies.

(■ Observed, □ Expected)

Figure 3. Defects in heart development in E10.5 mutant embryos

Parasagittal sections of (A) *erbB-2^{KI/KI}*, (B) *erbB-2^{WT/KD}* and (C) *erbB-2^{KD/KD}* embryos at E10.5 were stained with hematoxylin and eosin. Although heartbeats were detected at the time of dissection, histological examinations of the hearts revealed a lack of trabeculae in the ventricles of *erbB-2^{KD/KD}* mutants but were present in heterozygous littermates and in age-matched *erbB-2^{KI/KI}* knock-in embryos.

t, trabeculae; v, ventricle; ec, endocardial cushion; a, atrium.

Figure 4. Lack of sympathetic chain ganglia in kinase-dead mutants

Day E10/E11 embryos were subjected to wholemount *in situ* hybridization analysis using an anti-sense Phox-2a riboprobe. Normal sympathetic chain ganglia development was present in (A & B) $erbB-2^{WT/WT}$ embryos and (C & D) $erbB-2^{WT/KD}$ heterozygous embryos, whereas (E & F) $erbB-2^{KD/KD}$ homozygous mutants lacked proper development or they were delayed in (G & H) $erbB-2^{KI/KI}$ embryos. The white arrowheads highlight the developing sympathetic chain ganglia

Figure 5. Detection of ErbB-2 expression in E10.5 embryos

Expression of ErbB-2 generated from the cDNA insert in *erbB-2^{KI/KI}* and *erbB-2^{KD/KD}* embryos was determined. For (A) immunoblot analyses, total protein isolated from E10.5 embryos were subjected to SDS-PAGE and incubated with an anti-ErbB-2 antibody. Detection of Grb-2 (lower panel) protein was used to control for equal protein lysate quantification. (B) RNase protection assays with an anti-sense *erbB-2* riboprobe were employed to detect *erbB-2* transcripts in total RNA isolated from *erbB-2^{w^t/w^t}* (lane 1), *erbB-2^{KD/KD}* (lanes 3 & 4), and *erbB-2^{KI/KI}* (lanes 6 & 7) embryos. A mouse phosphoglycerate kinase (PGK) riboprobe (lower panel) was used as an internal control for equal sample loading in each lane.

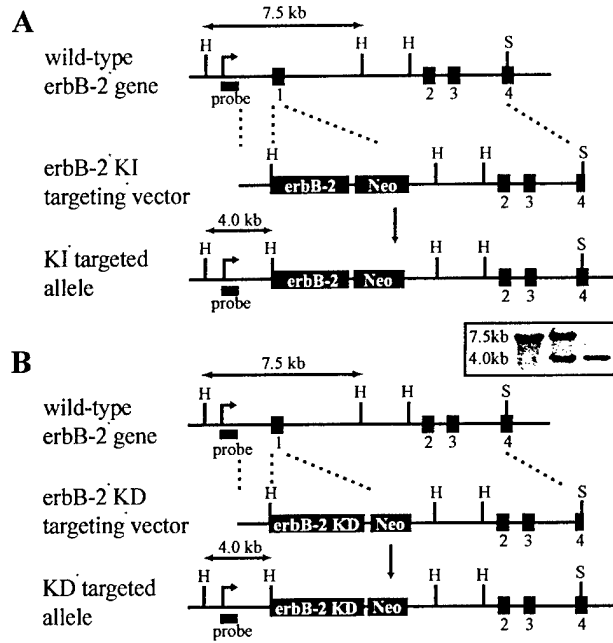

Figure 1

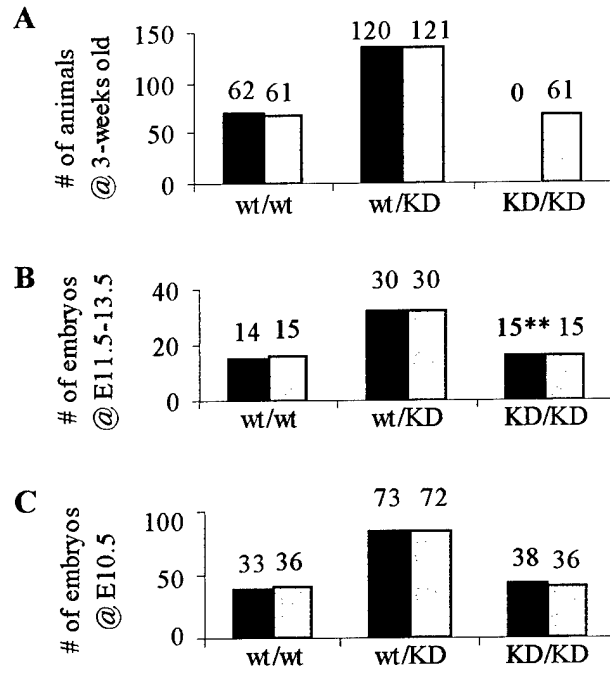

Figure 2



Figure 3

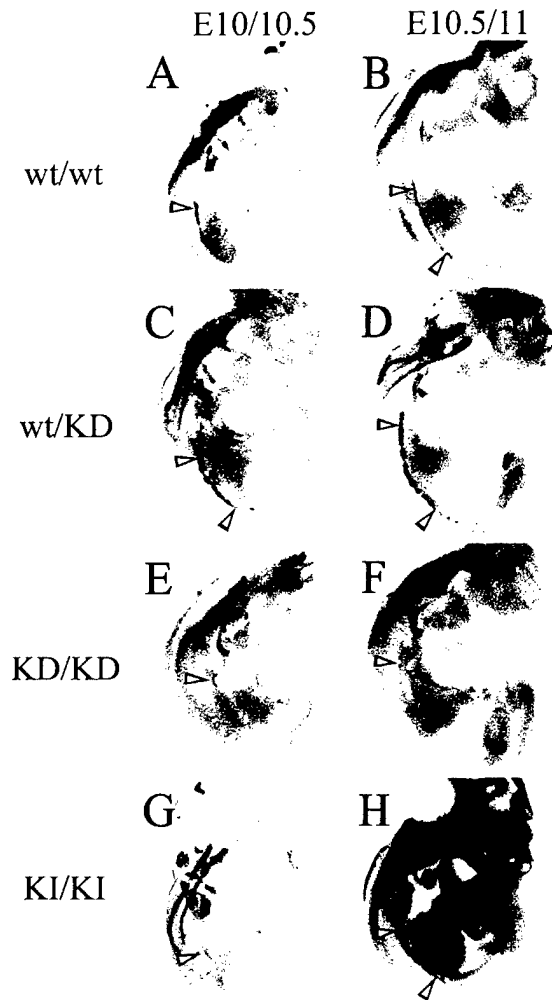

Figure 4

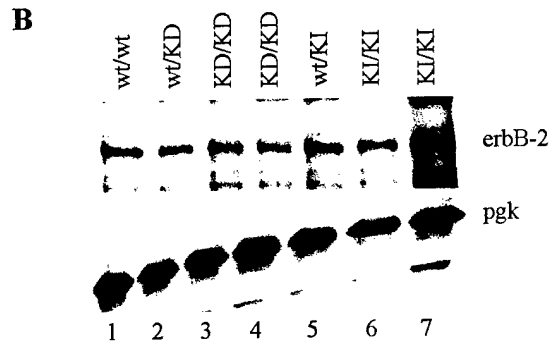
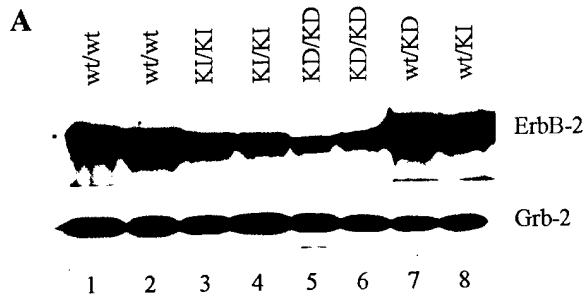

Figure 5