

NASA TECHNICAL
MEMORANDUM

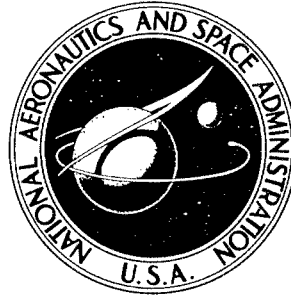

B054449

NASA TM X-935

NASA TM X-935

N 64-10456

AMPTIAC

DISTRIBUTION STATEMENT A
Approved for Public Release
Distribution Unlimited

54443

ULTRASONIC WELDING OF A
BERYLLIUM WINDOW ASSEMBLY

*by J. A. Munford, B. R. Cantor,
and A. Piltch*

Reproduced From
Best Available Copy

*Goddard Space Flight Center
Greenbelt, Maryland*

20020110 098

ULTRASONIC WELDING OF A
BERYLLIUM WINDOW ASSEMBLY

J. A. Munford, B. R. Cantor, and A. Pilch

Goddard Space Flight Center
Greenbelt, Maryland

NATIONAL AERONAUTICS AND SPACE ADMINISTRATION

ULTRASONIC WELDING OF A BERYLLIUM WINDOW ASSEMBLY

by

J. A. Munford, B. R. Cantor, and A. Piltch

Goddard Space Flight Center

SUMMARY

[^{Be, SS, Al} A method of fabricating thin beryllium window assemblies in rigid frames by ultrasonic welding of thin (0.001 inch) beryllium foil to AISI 310 stainless steel is described. Interleaf rings of 0.001-inch aluminum foil are used between the beryllium and stainless steel for cushioning and to reduce power requirements. Vacuum-tight joints were achieved, but metallographic examinations indicate the need for improved beryllium.]

[Spalling attributed to deformation of a land designed into the joint, and vibration of the unsupported beryllium also caused problems.]

end
RUC
3/2/64

CONTENTS

Summary	i
INTRODUCTION	1
DESIGN OF THE BERYLLIUM WINDOW ASSEMBLY	1
FABRICATION	2
TESTS AND RESULTS	2
Helium Leak Tests	2
Metallographic Examination	3
Discussion	5
CONCLUSION	5

ULTRASONIC WELDING OF A BERYLLIUM WINDOW ASSEMBLY

(Manuscript Received July 23, 1963)

by

J. A. Munford, B. R. Cantor, and A. Piltch

Goddard Space Flight Center

INTRODUCTION

Thin beryllium windows in rigid frames are required for use with low energy radiation detectors. Such assemblies have been fabricated by brazing, but with inconsistent results. In an effort to eliminate the heat effects of brazing, the Goddard Space Flight Center (GSFC) contracted with Aeroprojects, Inc., West Chester, Pennsylvania, to develop techniques for ultrasonic welding of 0.001-inch beryllium foil to AISI 310 stainless steel rings to provide unobstructed windows 3/4 inch in diameter. Upon completion of the task, three window assemblies were furnished by the contractor, together with a letter report of the procedures used in fabrication and preliminary metallographic evaluation of the welds. Additional metallographic studies were conducted at GSFC for further evaluation of the welds and the effects of the process on the beryllium.

DESIGN OF THE BERYLLIUM WINDOW ASSEMBLY

The GSFC design as modified by Aeroprojects, shown in Figure 1, is based on past experience in welding beryllium to dissimilar metals. An annular land area 0.020 inch wide by 0.003 inch high on the ring provides a restricted area for welding and thus reduces power requirements. An interleaving ring of 0.001-inch aluminum foil is used between the beryllium and stainless steel for further reduction of power and for cushioning the beryllium. A completed weld assembly is shown in Figure 2.

The beryllium disks, made from QMV* hot-rolled beryllium stock, were obtained from the

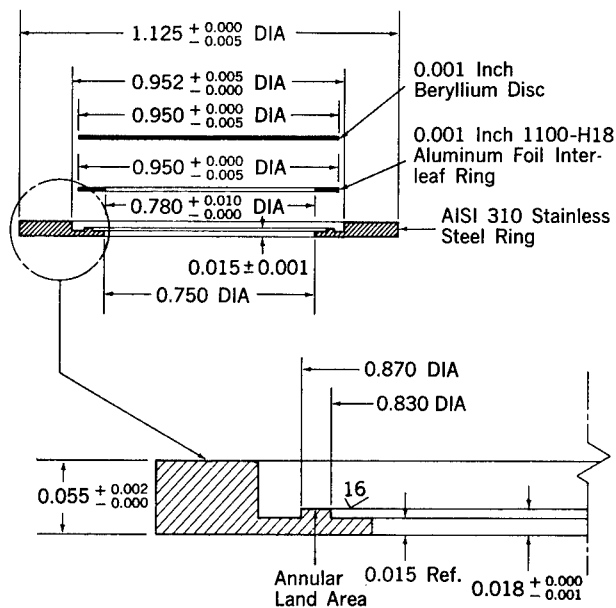

Figure 1—Exploded view of modified beryllium window assembly.

*Registered trade mark.

Brush Beryllium Co., Cleveland, Ohio. Fourteen disks were procured for this work. Four of these leaked when tested on a helium mass spectrometer leak detector, and these were used as test pieces in fabricating the first assemblies. The stainless steel rings were machined from 1.25-inch-diameter annealed AISI 310 stainless steel bar stock. The foil interleaf rings were made of 0.001-inch aluminum alloy 1100-H18.

FABRICATION

The welding was performed on a new laboratory model ultrasonic ring welder, which operates at a nominal frequency of 15 kilocycles per second. A sonotrode with an annular welding tip of 0.790 to 0.910 inch diameter was employed, allowing the welding tip to overlap the land area by about 0.020 inch on each side. A locating and centering fixture was used to position and support the assembly during welding.

To conserve beryllium, preliminary machine settings were established by welding 0.001-inch AISI 302-1/2H stainless steel foil disks to stainless steel rings of the dimensions shown in Figure 1, using the 1100-H18 aluminum foil interleaf. The optimum settings for this assembly were: power, 1400 watts; time interval, 1.0 second (energy 1400 watt-seconds); clamping force, 700 pounds. Tests showed that these assemblies were sound, helium leak-tight, and free of cracks.

The settings initially used for welding the beryllium window assembly were calculated from the foregoing values by making allowance for hardness differences. On the first units, made with the disks which were not leak-tight, the beryllium was peeled back to examine the bond. On the basis of this examination, the final settings were: power, 1000 watts; time interval, 1/2 second (energy 500 watt-seconds); clamping force, 500 pounds.

TESTS AND RESULTS

Helium Leak Tests

The instrument used for these tests was a mass spectrometer leak detector, calibrated to a sensitivity of $2.2 \times 10^{-10} \text{ cm}^3/\text{sec}$ at STP. Tests verified by strength calculations indicated that an edge-restrained 3/4-inch diameter beryllium disk 0.001 inch thick would not withstand the 15 psi pressure differential used in the test. A fixture was therefore used to provide support for the beryllium window and prevent dishing or imploding. No leakage was detected on any of the welded units in which the beryllium had been leaktight originally.

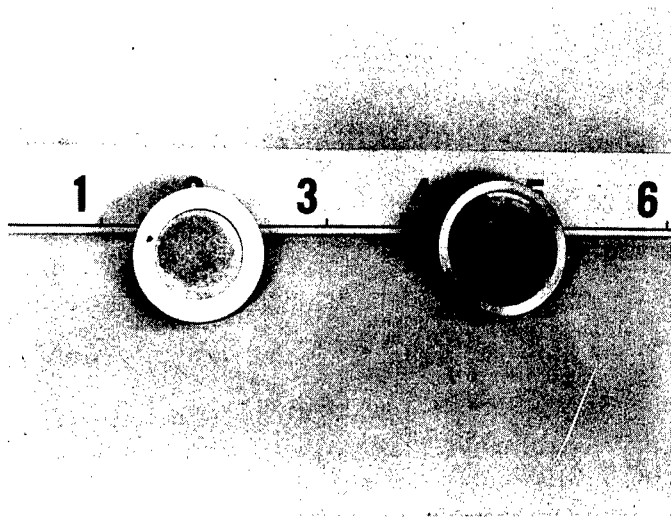

Figure 2—Welded beryllium window assembly, front and back.

Metallographic Examination

The welded specimens were sectioned tangentially (Figure 3), to include portions of the weld area throughout its diameter. The sections were ground, polished, etched, and then examined metallographically. A typical section at the weld is shown in Figure 4. Sound bonds are apparent at both the beryllium-aluminum and the aluminum-stainless steel interfaces, but numerous voids or oxide inclusions extending far into the beryllium are evident, and these reflect the quality of the beryllium used. Although no individual voids appear to penetrate the beryllium, it is possible that a network of such voids might "tunnel" completely through and result in leakage.

A portion of the section at the edge of the land area is shown in Figure 5. A sound bond is apparent over the land where pressure was applied. Deformation of both the aluminum and beryllium has occurred beyond the land. The section beyond the land (Figure 6), shows damage to the beryllium; spalling has occurred beyond the contact area of the sonotrode and land.

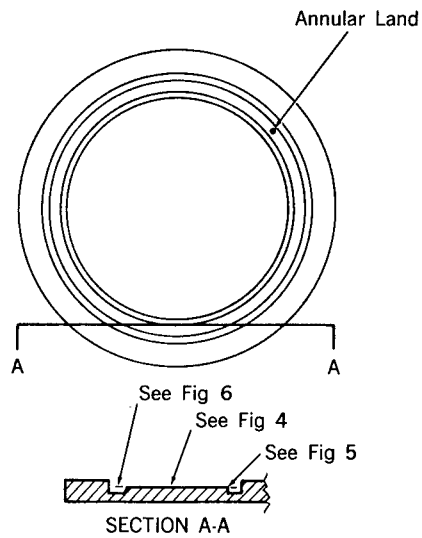

Figure 3—Beryllium window assembly, showing position of section for metallographic examination.

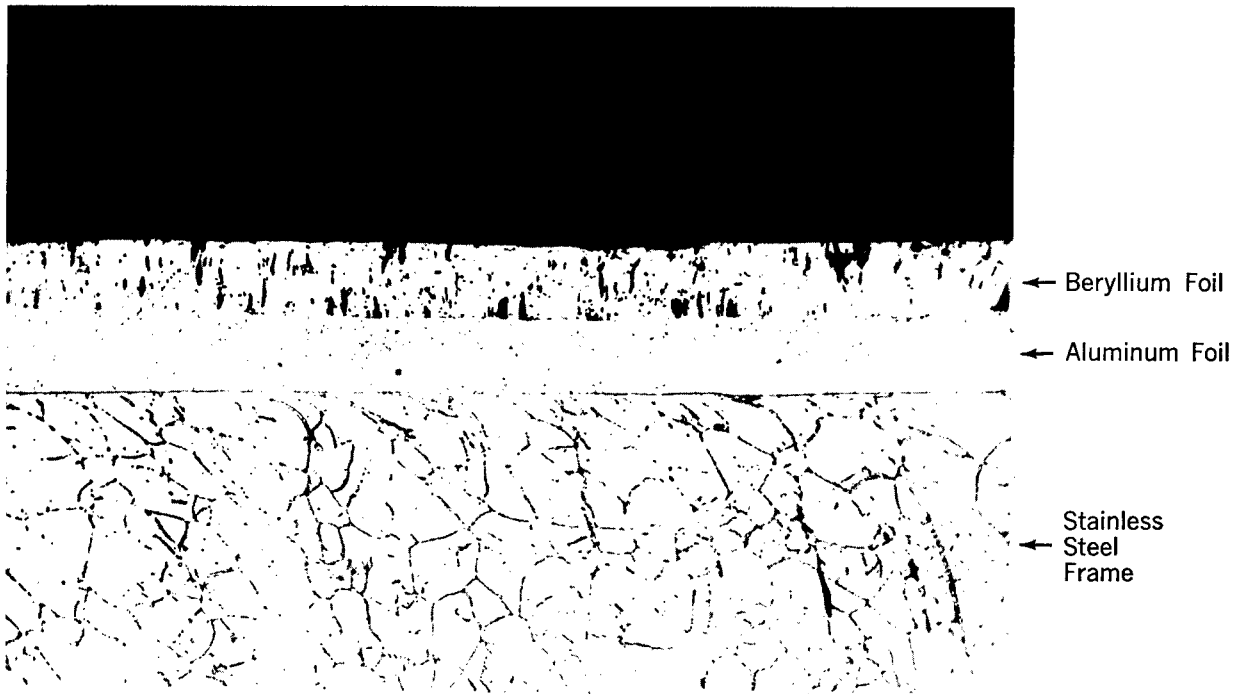

Figure 4—Photomicrograph (500X) of ultrasonic weld within the land. Stainless steel frame electrolytically etched in 10 percent oxalic acid. Beryllium etched in 10 percent HF, 90 percent ethanol.

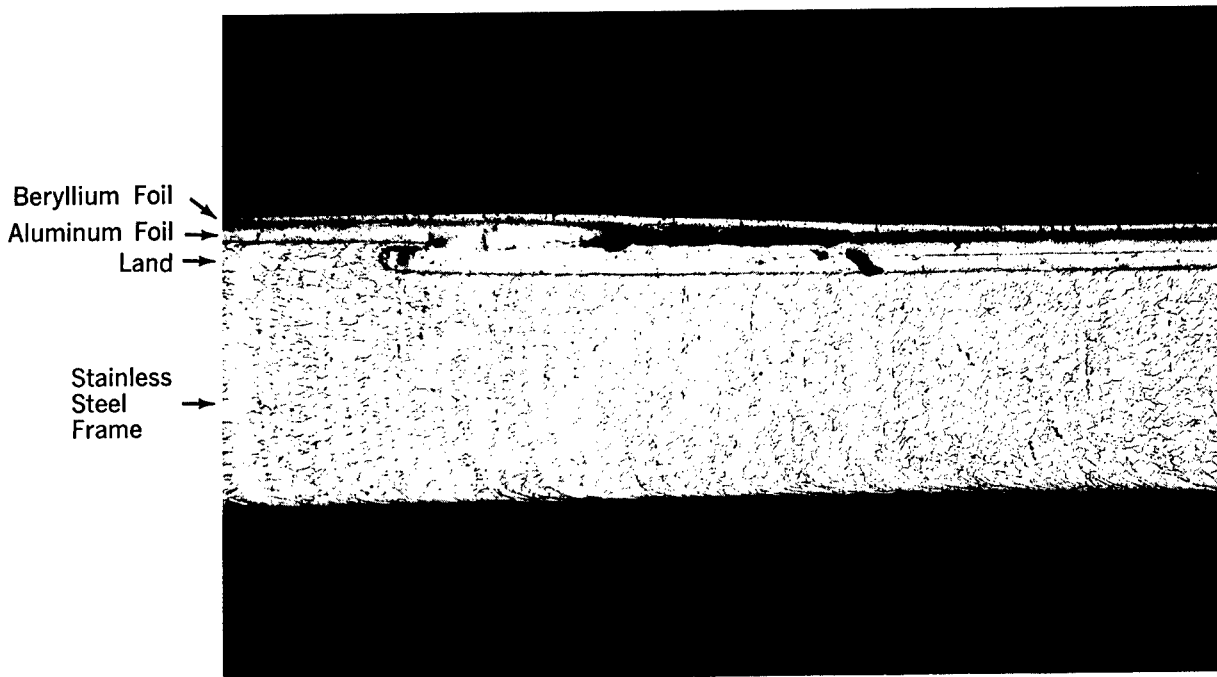

Figure 5—Photomicrograph (100X) of ultrasonic weld at edge of land. Stainless steel frame electrolytically etched in 10 percent oxalic acid. Beryllium etched in 10 percent HF, 90 percent ethanol.



Figure 6—Photomicrograph (500X) beyond ultrasonic weld, showing foil damage. Stainless steel frame etched electrolytically in 10 percent oxalic acid. Beryllium etched in 10 percent HF, 90 percent ethanol.

Discussion

Although the window assemblies successfully passed helium leak detector tests, it is believed that considerable improvement is necessary in the quality of the beryllium foil. Sounder material, greater strength, and higher ductility are all required. The presence of the deep voids in the foil used obviously raises the actual stress level far above that designed for. Whether the original design itself is suitable is also a question. If sound beryllium were available, and the beryllium in this thickness range could be depended upon for a 50,000 p.s.i. strength level, the design would probably be satisfactory; at a 40,000 p.s.i. level, at least a 0.0017 inch foil thickness would be required. At the latter strength level, a 1/2 inch diameter appears to be the maximum possible with the 0.001 inch foil.

The spalling noted adjacent to the land is attributed both to deformation of the land itself and to the introduction of ultrasonic energy causing induced vibration in unsupported beryllium of poor quality. The tendency to spall should be lessened in sound beryllium. In addition, it may be reduced by changes in welding practice, such as narrowing the annulus of the sonotrode or providing damping for the unsupported section of the beryllium.

CONCLUSION

Ultrasonic welding is feasible for obtaining vacuum-tight joints between thin beryllium disks and stainless steel rings. It is expected that availability of higher quality beryllium foil and some modification in welding practice will result in assemblies of sounder construction.

It is planned to determine the availability of beryllium foil of improved soundness and superior mechanical properties for use in fabricating additional window assemblies. Modifications in welding practice will be made to minimize the spalling tendency. The program will also include evaluation of the assemblies under vibration and acceleration.

<p>NASA TM X-935 National Aeronautics and Space Administration. ULTRASONIC WELDING OF A BERYLLIUM WINDOW ASSEMBLY. J. A. Munford, B. R. Cantor, and A. Piltch. January 1964. iii, 5p. OTS price, \$0.50. (NASA TECHNICAL MEMORANDUM X-935)</p> <p>A method of fabricating thin beryllium window assemblies in rigid frames by ultrasonic welding of thin (0.001 inch) beryllium foil to AISI 310 stainless steel is described. Interleaf rings of 0.001-inch aluminum foil are used between the beryllium and stainless steel for cushioning and to reduce power requirements. Vacuum-tight joints were achieved, but metallographic examinations indicate the need for improved beryllium.</p>	<p>NASA TM X-935 National Aeronautics and Space Administration. ULTRASONIC WELDING OF A BERYLLIUM WINDOW ASSEMBLY. J. A. Munford, B. R. Cantor, and A. Piltch. January 1964. iii, 5p. OTS price, \$0.50. (NASA TECHNICAL MEMORANDUM X-935)</p> <p>A method of fabricating thin beryllium window assemblies in rigid frames by ultrasonic welding of thin (0.001 inch) beryllium foil to AISI 310 stainless steel is described. Interleaf rings of 0.001-inch aluminum foil are used between the beryllium and stainless steel for cushioning and to reduce power requirements. Vacuum-tight joints were achieved, but metallographic examinations indicate the need for improved beryllium.</p>	<p>I. Munford, J. A. II. Cantor, B. R. III. Piltch, A. IV. NASA TM X-935</p> <p>NASA</p>	<p>I. Munford, J. A. II. Cantor, B. R. III. Piltch, A. IV. NASA TM X-935</p> <p>NASA</p>
<p>NASA TM X-935 National Aeronautics and Space Administration. ULTRASONIC WELDING OF A BERYLLIUM WINDOW ASSEMBLY. J. A. Munford, B. R. Cantor, and A. Piltch. January 1964. iii, 5p. OTS price, \$0.50. (NASA TECHNICAL MEMORANDUM X-935)</p> <p>A method of fabricating thin beryllium window assemblies in rigid frames by ultrasonic welding of thin (0.001 inch) beryllium foil to AISI 310 stainless steel is described. Interleaf rings of 0.001-inch aluminum foil are used between the beryllium and stainless steel for cushioning and to reduce power requirements. Vacuum-tight joints were achieved, but metallographic examinations indicate the need for improved beryllium.</p>	<p>NASA TM X-935 National Aeronautics and Space Administration. ULTRASONIC WELDING OF A BERYLLIUM WINDOW ASSEMBLY. J. A. Munford, B. R. Cantor, and A. Piltch. January 1964. iii, 5p. OTS price, \$0.50. (NASA TECHNICAL MEMORANDUM X-935)</p> <p>A method of fabricating thin beryllium window assemblies in rigid frames by ultrasonic welding of thin (0.001 inch) beryllium foil to AISI 310 stainless steel is described. Interleaf rings of 0.001-inch aluminum foil are used between the beryllium and stainless steel for cushioning and to reduce power requirements. Vacuum-tight joints were achieved, but metallographic examinations indicate the need for improved beryllium.</p>	<p>I. Munford, J. A. II. Cantor, B. R. III. Piltch, A. IV. NASA TM X-935</p> <p>NASA</p>	<p>I. Munford, J. A. II. Cantor, B. R. III. Piltch, A. IV. NASA TM X-935</p> <p>NASA</p>