

**UNITED STATES AIR FORCE
RESEARCH LABORATORY**

**LACK OF EFFECTS ON GOAL-DIRECTED
BEHAVIOR OF HIGH-INTENSITY INFRASOUND
IN A RESONANT REVERBERANT CHAMBER**

**Michael C. Cook
Clifford F. Sherry
Caroll G. Brown**

**Veridian Engineering
9601 McAllister Freeway, Ste 1165
San Antonio, TX 78216**

James R. Jauchem

**HUMAN EFFECTIVENESS DIRECTORATE
DIRECTED ENERGY BIOEFFECTS DIVISION
RADIO FREQUENCY RADIATION BRANCH
8315 Hawks Road
Brooks AFB, Texas 78235**

November 2001

Approved for public release; distribution unlimited.

20020130 240

NOTICES

This report is published in the interest of scientific and technical information exchange and does not constitute approval or disapproval of its ideas or findings.

This report is published as received and has not been edited by the publication staff of the Air Force Research Laboratory.

Using Government drawings, specifications, or other data included in this document for any purpose other than Government-related procurement does not in any way obligate the US Government. The fact that the Government formulated or supplied the drawings, specifications, or other data, does not license the holder or any other person or corporation, or convey any rights or permission to manufacture, use, or sell any patented invention that may relate to them.

The Office of Public Affairs has reviewed this paper, and it is releasable to the National Technical Information Service, where it will be available to the general public, including foreign nationals.

This report has been reviewed and is approved for publication.

JAMES R. JAUCHEM, Ph.D.
Contract Scientist

RICHARD MILLER, Ph.D.
Chief, Directed Energy Bioeffects Division

REPORT DOCUMENTATION PAGE

Form Approved
OMB No. 0704-01-0188

The public reporting burden for this collection of information is estimated to average 1 hour per response, including the time for reviewing instructions, searching existing data sources, gathering and maintaining the data needed, and completing and reviewing the collection of information. Send comments regarding this burden estimate or any other aspect of this collection of information, including suggestions for reducing the burden to Department of Defense, Washington Headquarters Services Directorate for Information Operations and Reports (0704-0188), 1215 Jefferson Davis Highway, Suite 1204, Arlington VA 22202-4302. Respondents should be aware that notwithstanding any other provision of law, no person shall be subject to any penalty for failing to comply with a collection of information if it does not display a currently valid OMB control number.

PLEASE DO NOT RETURN YOUR FORM TO THE ABOVE ADDRESS.

1. REPORT DATE (DD-MM-YYYY) 28-11-2001		2. REPORT TYPE Interim		3. DATES COVERED (From - To) Jan 1999-Aug 2000	
4. TITLE AND SUBTITLE Lack of Effects on Goal-Directed Behavior of High-Intensity Infrasonic in a Resonant Reverberant Chamber				5a. CONTRACT NUMBER F41624-96-C-9009	
				5b. GRANT NUMBER N/A	
				5c. PROGRAM ELEMENT NUMBER 62202F	
6. AUTHORS Cook, Michael C., Sherry, Clifford F., Brown, G. Carroll, Jauchem, James R., and Fines, David A.				5d. PROJECT NUMBER 7757	
				5e. TASK NUMBER B3	
				5f. WORK UNIT NUMBER 17	
7. PERFORMING ORGANIZATION NAME(S) AND ADDRESS(ES) Veridian Engineering 9601 McAllister Freeway, Suite 1165 San Antonio, TX 78216				8. PERFORMING ORGANIZATION REPORT NUMBER N/A	
9. SPONSORING/MONITORING AGENCY NAME(S) AND ADDRESS(ES) Air Force Research Laboratory (AFMC) Human Effectiveness Directorate Directed Energy Bioeffects Division, Radio Frequency Radiation Branch 8315 Hawks Road Brooks Air Force Base, TX 78235				10. SPONSOR/MONITOR'S ACRONYM(S) AFRL	
				11. SPONSOR/MONITOR'S REPORT NUMBER(S) AFRL-HE-BR-TR-2001-0154	
12. DISTRIBUTION/AVAILABILITY STATEMENT Approved for public release.					
13. SUPPLEMENTARY NOTES AFRL Technical Monitor: James H. Merritt, (210) 536-4703.					
14. ABSTRACT It has been hypothesized that high-intensity low-frequency sound (20-100 Hz) and infrasound (below 20 Hz) could incapacitate personnel located within buildings or underground facilities. A unique reverberant resonant chamber was designed and constructed of reinforced concrete, and incorporated a moveable wall to allow tuning to specific frequencies. Two minipigs (<i>Sus scrofa</i>) were trained to press a panel for food delivery. The tuning wall was positioned to create standing waves of maximal intensity at frequencies of 10, 12, 15, and 20 Hz. Four "subwoofer" speakers were used to produce sinusoidal signals at the tuned frequency of the chamber, and at 2 and 4 times the tuned frequency. Over numerous trials, there was only a minimal impact on consummatory and escape behavior that rapidly dissipated with repeated exposures. In another series, 2 rhesus monkeys (<i>Macaca mulatta</i>) were trained on a continuous, compensatory-tracking task. The tuning wall was set for 10 Hz, with signals at 10 and 20 Hz. Subject behavior was not substantially affected. It seems unlikely that high-intensity acoustic energy (20-80 Hz, up to 145 dB) can be used to facilitate hostage rescue. Due to the difficulty of obtaining high sound pressure levels in a large volume, further extensive experimentation is not suggested.					
15. SUBJECT TERMS Acoustic Energy, Animal Behavior, Non-Lethal, Sound, Infrasound					
16. SECURITY CLASSIFICATION OF:			17. LIMITATION OF ABSTRACT	18. NUMBER OF PAGES	19a. NAME OF RESPONSIBLE PERSON
a. REPORT	b. ABSTRACT	c. THIS PAGE			James R. Jauchem
U	U	U	UU	38	19b. TELEPHONE NUMBER (Include area code) (210) 536-3572

TABLE OF CONTENTS

	<i>Page</i>
INTRODUCTION	1
Need for Non-Lethal Weapons	1
Evidence Supporting Infrasound's Effectiveness	1
NIJ Connection and AFRL Expertise	3
GENERAL METHODS AND PROCEDURES	3
Subjects	3
Apparatus and Data Analysis	4
Resonant Chamber	4
Sound Generation	10
Sound Measurement	14
RESONANT CHAMBER ACOUSTIC MAPPING	15
Apparatus	15
Procedure and Data Analysis	15
Results and Discussion	16
EFFECTS OF SRT SPEAKER OUTPUT ON SWINE OPERANT BEHAVIOR	20
Subjects	20
Apparatus	20
Procedure and Data Analysis	21
Pre-Exposure	21
Exposure to SRT Speakers	21
Results	22
EFFECTS OF SRT SPEAKER OUTPUT ON RHESUS MONKEY BEHAVIOR	23
Subjects	23
Apparatus	23
Procedure and Data Analysis	24
Results	25
GENERAL DISCUSSION	29
Significance of the Results of the Present Experiments and Previous Acoustic Experiments Performed by the Directed Energy Division	29
Effects of Different Materials on Surfaces of Rooms	30
Is the Potential of Infrasound Overrated?	30
The Likelihood of Future Success in the Use of Infrasound for Hostage Rescue	31
CONCLUSIONS	32
ACKNOWLEDGEMENTS	33
REFERENCES	34

List of Figures

<i>Fig. No.</i>		<i>Page</i>
Figure 1.	Amplitude of standing waves in a resonant chamber as a function of chamber length and signal frequency.	4
Figure 2.	Foundation preparation for the resonant chamber, showing the three rails on which the tuning wall traveled.	5
Figure 3.	Installation of the reinforced concrete wall panels of the chamber.	6
Figure 4.	Securing the ceiling panels to the walls of chamber.	6
Figure 5.	View of the erected chamber from the side where the tuning wall will be inserted.	7
Figure 6.	View of the tuning wall at the far end of the chamber prior to the wall's completion and insertion into the chamber.	7
Figure 7.	One set of track wheels and an outrigger wheel attached to the tuning wall, and one of the three tracks on which the tuning wall moved.	8
Figure 8.	The motor and motor controller used to move the tuning wall.	8
Figure 9.	The uninflated bladder used with the tuning wall.	9
Figure 10.	Schematic view of one half of a speaker cabinet designed by Sound Related Technologies.	11
Figure 11.	The four speaker cabinets mounted on a wooden stand inside of the resonant test chamber. Stereo amplifiers (one per cabinet) were situated on shelving immediately below the cabinets.	13
Figure 12.	A simplified wiring schematic for production of audio signals (only depicts one amplifier and one speaker).	14
Figure 13.	A schematic illustrating, in part, the procedure used in the measurement of speaker impedance.	14
Figure 14.	A Fast Fourier Transform of a 20-Hz sinusoidal signal measured at 6 m from speakers in the test chamber when tuned at 10 Hz.	16
Figure 15.	Amplitude of 10-, 20-, and 40-Hz signals within the resonant chamber tuned to 10 Hz. Pig and monkey icons indicate subject locations.	17
Figure 16.	Amplitude of 12-, 24-, and 48-Hz signals within the resonant chamber tuned to 12 Hz. Pig icon indicates subject location.	17
Figure 17.	Amplitude of 15-, 30-, and 60-Hz signals within the resonant chamber tuned to 15 Hz. Pig icon indicates subject location.	18
Figure 18.	Amplitude of 20-, 40-, and 80-Hz signals within the resonant chamber tuned to 20 Hz. Pig icon indicates subject location.	18
Figure 19.	Resonance chamber gain as a function of four tuned frequencies.	19
Figure 20.	The panel-press apparatus used with swine subjects.	21
Figure 21.	The Primate Equilibrium Platform inside of the resonant chamber.	24
Figure 22.	Performance of rhesus subject (510Z) on Primate Equilibrium Platform during first exposure session.	26
Figure 23.	Performance of rhesus subject (952Z) on Primate Equilibrium Platform during first exposure session.	26
Figure 24.	Performance of rhesus subject (510Z) on Primate Equilibrium Platform during second exposure session.	27
Figure 25.	Performance of rhesus subject (952Z) on Primate Equilibrium Platform during second exposure session.	27

Figure 26. Performance of rhesus subject (510Z) on Primate Equilibrium Platform during third exposure session.28

Figure 27. Performance of rhesus subject (952Z) on Primate Equilibrium Platform during third exposure session.29

List of Tables

<i>Table No.</i>		<i>Page</i>
Table 1.	Proportion of signals during which an effect on subject escape behavior was observed.	23
Table 2.	Proportion of signals during which an effect on subject consummatory behavior was observed.	23

INTRODUCTION

Need for Non-Lethal Weapons

Terrorism poses a growing threat domestically and internationally. Combating terrorism is a common mission of both military and law enforcement communities. One of the most frequently cited technical needs, according to law enforcement officers and other individuals who coordinate agency responses to terrorist incidents, is “improved non-lethal weapons to apprehend terrorists” (Stambaugh et al., 1999). The Office of Science and Technology within the National Institute of Justice (NIJ) has inaugurated a technology initiative to address this threat. This initiative focuses on four thrust areas, one of which is hostage rescue. Rescuing hostages intermingled with their captors poses a considerable challenge to law enforcement and to technology developers. A desirable scenario would be to “incapacitate” all the occupants in an enclosed area with a non-lethal technology and then safely sort the hostages from the captors. Specifically, it was hypothesized that high-intensity low-frequency sound (20-100 Hz) and infrasound (below 20 Hz) could be used to incapacitate personnel located within buildings or underground facilities.

Since non-lethal concepts are the result of new and “less conventional” weapons research areas, they have lacked traditional, well-defined war fighting requirements and doctrine (Barry et al., 1994). It has often been the availability of new technology that has driven research rather than a well-defined requirement utilizing technology as a tool. While some non-lethal weapons may substitute for lethal weapons in certain combat missions, others may open up new missions altogether (Coppennoll, 1999) (e.g., hostage rescue). Some weapons, such as those that would use infrasound, will not discriminate between combatants and noncombatants. In spite of this, however, they may be acceptable if their effects are temporary and significantly less destructive than those of lethal weapons (Hannigan et al., 1996). The use of such weapons would be applicable in a hostage rescue situation.

Evidence Supporting Infrasound's Effectiveness

Experimental evidence indicates that infrasound frequencies can cause a variety of sensations and physiological effects that may lead to changes in behavior of the targeted individual. One of the first studies to describe the effects of high-intensity, low-frequency sound on humans was done by von Békésy (1936); when he exposed subjects to high-intensity sound, the threshold for pain decreased from 179 dB at static pressure to 165 dB at 3 Hz, and to 140 dB at frequencies from 15 Hz to well above 100 Hz. In that same year, Wever and Bray (1936) found that their subjects reported slight dizziness, nausea, and feelings of apprehension when exposed to 5 to 60 Hz at about 104 dB.

In the mid 1960's, the US Air Force (USAF) and the National Aeronautics and Space Administration (NASA) became concerned about the possible extra-aural effects of high-intensity, low-frequency sound inside space capsules and the area around the launch site during launch of Apollo space vehicles (Mohr et al., 1965). The exhaust noise of a large rocket engine can reach levels well above 130 dB in the 20-100 Hz frequency range and remain well above 100 dB at frequencies as low as 5 Hz. Mohr et al. (1965) reported coughing and choking at 50-100

Hz at intensities of 150-154 dB; they also found that workers exhibited a generalized stress reaction and a greater degree of fatigue than would be expected.

Infrasound can be sensed as vibrations of the eardrum (Nixon, 1974) or the skin (Cole et al., 1966; von Gierke and Parker, 1976). Although sounds below 20-30 Hz are not heard, humans report that when intensities reach approximately 125 dB, the eardrum feels as though it is being massaged at the frequency of stimulation. Relatively short exposures (e.g., six exposures of 5 min each at 18 Hz) at 125 dB can cause a temporary threshold shift for 30 min (Nixon, 1974). The detection thresholds for the "massaging" sensation range from 90 dB at 20 Hz up to 140 dB at 1 Hz, while the pain threshold ranges from about 140 dB at 20 Hz to 162 dB at 2 Hz (von Gierke and Parker, 1976).

Lim et al. (1982) found that in chinchillas, whose hearing response curves resemble those of humans, continuous infrasound exposure was more damaging than intermittent exposures. Stimulation at 1-20 Hz at intensities as high as 170 dB could cause damage to the middle and inner ear, such as saccular pathology, perforations of the tympanic membrane, hair cell damage, bleeding of the cochlear scalae, and rupture of the Reissner's membrane (Lim et al., 1982). Standard noise protection ear muffs provide relatively little attenuation at infrasound frequencies (Nixon et al., 1967).

Infrasound can couple to air-filled and fluid-filled organs at the resonant frequencies of those organs. This coupling could be sensed as unusual or uncomfortable by proprioceptors or nociceptors innervating these organs; alternatively, coupling-induced movements could cause an alteration of the function of these organs. Slarve and Johnson (1975) found that humans experienced vibrations of the chest and abdomen at frequencies between 4 and 25 Hz, with a threshold at 8 Hz of 132 dB. Their subjects also reported a painless sound-induced pressure buildup in their ears between 1 and 20 Hz, where the threshold at 8 Hz was between 120 and 126 dB. This phenomenon did not occur above 25 Hz. Johnson (1973) found that he could cause a decline or cessation of breathing in anesthetized dogs at an intensity of 165 dB at 1-8 Hz. In unanesthetized dogs, however, no obvious changes in respiration were noted. Recent work done at Brooks AFB also indicated that the lungs of an anesthetized pig could be artificially ventilated at about 165 dB at 0.5 Hz in an enclosed chamber known as the Infrasound Test System (ITS) (Sherry et al., 2001a); further, primates in the ITS would stop performing a task at which they were very proficient (Sherry et al., 2001b). Edge and Mayes (1966), conducting space vehicle launch work at NASA's Langley Low Frequency Noise Facility, showed that for infrasound exposures of 140-150 dB at frequencies less than 50 Hz, humans were annoyed and fatigued, performing tasks at a slower rate. Although controversial, it has been suggested that infrasound can directly impact the vestibular system, causing vertigo and, potentially, motion sickness (see Harris et al., 1976, and von Gierke and Parker, 1976, for a review of these papers).

On the basis of these promising data, which indicate a probable threshold intensity for behavioral change between 130 dB and 165 dB, the Air Force Research Laboratory (AFRL) proposed further biological effects research on exposure to infrasound/low sonic acoustics to NIJ. It was apparent from the research literature and the previous research done at Brooks AFB that, for current technology acoustic generating hardware, a closed exposure chamber was

necessary to achieve the acoustic intensities required to cause a robust behavioral change, such as work stoppage.

NIJ Connection and AFRL Expertise

While the Department of Defense (DoD) often uses the term “non-lethal weapons,” law enforcement agencies generally use the term “less-than-lethal weapons” (Anonymous, 1998), and define them as tools that cannot cause death, regardless of how they are used. Fischetti (1995) noted that many of the new less-than-lethal weapons projected to be used for law enforcement would probably be adapted from military technology. A Memorandum of Understanding between the DoD and the Department of Justice, authorized in 1994 (US House of Representatives, 1994), formally connected the military’s non-lethal research to civilian law enforcement agencies. This was done in part to facilitate the development, rapid deployment, and transition of technologies with applicability for law enforcement and military operations other than war. The DoD’s Non-Lethal Weapons Directorate maintains good contact with NIJ’s Less-Than-Lethal Technology Program (Council on Foreign Relations, 1999).

The NIJ and the AFRL Directed Energy Division at Brooks AFB initiated an Inter-Agency Agreement to investigate the utility and practicality of employing infrasound acoustic energy in hostage rescue situations in enclosed areas. The scope of the agreement contained an array of questions to be answered by AFRL’s research in order to assess the technology. These questions included:

- Can the biological responses of an individual in an enclosed space be altered by exposure to infrasound?
- Will this alteration result in incapacitation?
- What is the nature of that incapacitation (onset, duration, degree, variability among subjects)?
- What is the potential for this technology to cause permanent injury or death?
- How will different types of wall construction material affect the efficiency of infrasound technology with respect to incapacitation?

GENERAL METHODS AND PROCEDURES

Subjects

All animals used in the experiments described below were procured, maintained, and used in accordance with the Animal Welfare Act and the Guide for the Care and Use of Laboratory Animals prepared by the Institute of Laboratory Animal Resources, National Research Council, under protocols that were approved by the AFRL (Armstrong Site) Institutional Animal Care and Use Committee and by the USAF Surgeon General.

Apparatus and Data Analysis

Resonant Chamber. Before any experiments could be conducted, a unique test chamber had to be designed and constructed. It was critical that the chamber be frequency tunable to provide the maximum acoustic environment possible for the output of the acoustic source. This chamber would take advantage of a physical phenomenon known as a standing wave to produce the maximum acoustic environment at the desired frequencies. A standing wave is defined as the field pattern generated by two equal-amplitude propagating waves traveling in opposite directions. As a result of standing waves, the level of low-frequency and infrasonic noise varies considerably with position within a room (e.g., Olesen and Moller, 1998). The field pattern due to a standing wave is characterized by spatial points or planes of maximum field amplitude and other spatial points or planes of zero field amplitude displaced along the direction of propagation. The fundamental, resonant or first harmonic frequency for which a standing wave exists is determined by the dimensions of the chamber, primarily the length in our case. That relationship is defined in terms of the wavelength of the fundamental; that wavelength is equal to twice the length of the chamber. Thus, a closed chamber of length L has a fundamental wavelength of $2L$ and a fundamental frequency of s (speed of sound at a given temperature and pressure) divided by $2L$. The chamber of length L produces standing waves for the harmonics of the fundamental which are defined by multiplying the fundamental frequency by 2 for the second harmonic, by 3 for the third harmonic, etc. Figure 1 shows the standing wave patterns of the fundamental (first harmonic), second harmonic, third harmonic, and fourth harmonic of a closed chamber.

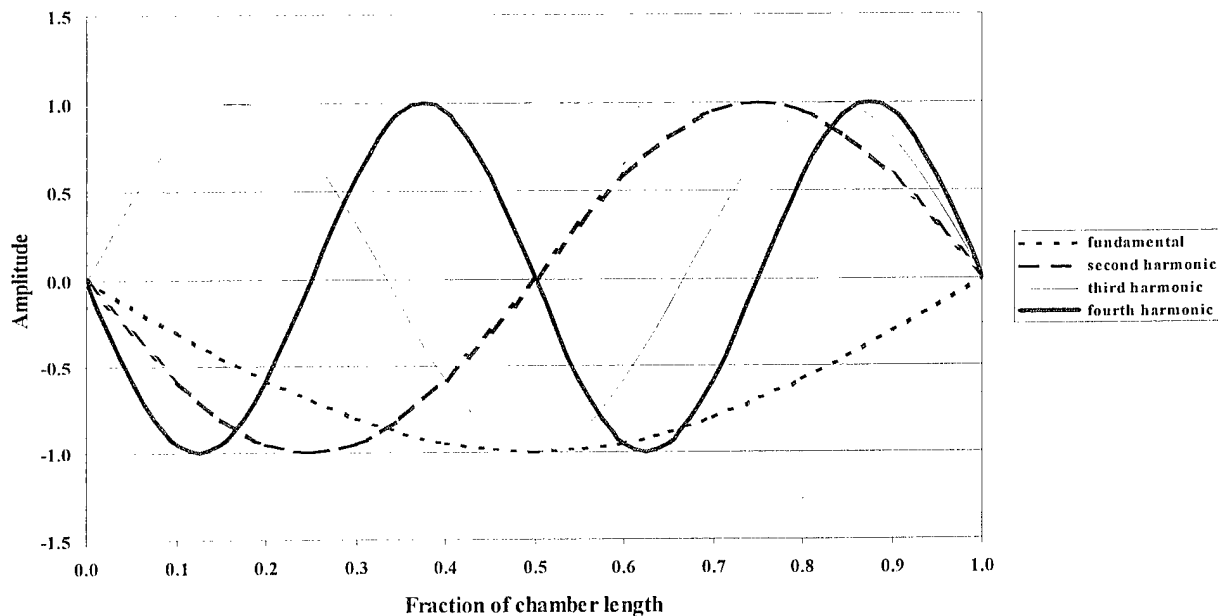

Figure 1. Amplitude of standing waves in a resonant chamber as a function of chamber length and signal frequency.

All experimental studies and acoustic measurements were performed inside of a tuned reverberant chamber, constructed of reinforced concrete (compressive strength of 4000 psi [27.6 MPa]). The interior dimensions of the chamber were 18.54 m long x 3.84 m wide x 3.78 m high. The ceiling, floor, and walls of the chamber were all 30.5 cm thick. The two walls running parallel to the long axis of the chamber (i.e., 18.54 m) were each composed of six separate concrete panels. The inside walls were further smoothed and evened by sanding. (The construction of the chamber walls was dictated by the high-intensity, low-frequency signals that had to be contained; the walls needed to be stiff enough so as not to flex and smooth enough to reflect maximum energy back into the chamber.) Figures 2 through 5 illustrate preliminary phases of the chamber's construction.

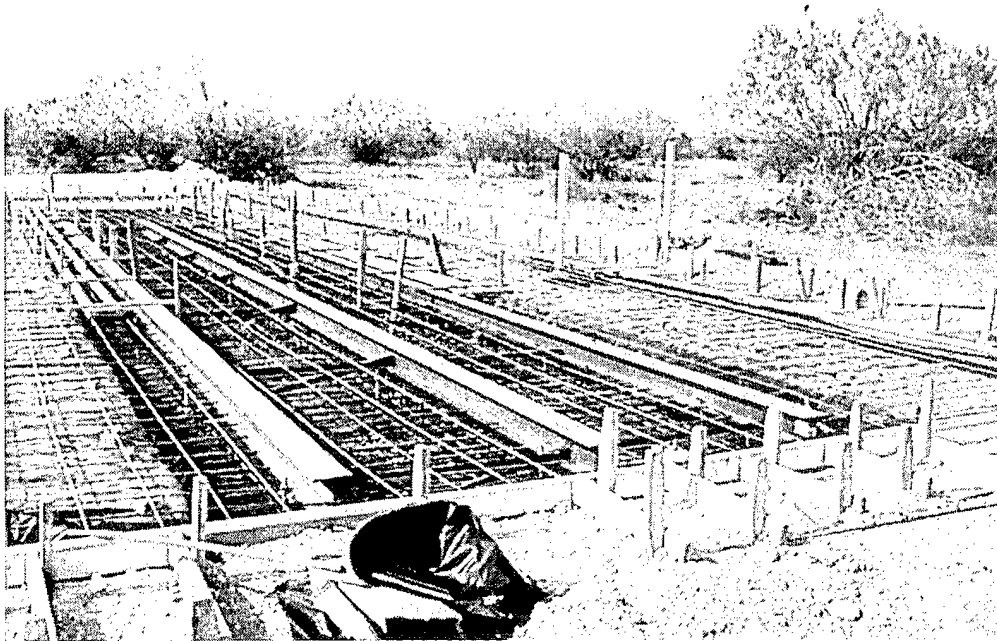

Figure 2. Foundation preparation for the resonant chamber, showing the three rails on which the tuning wall traveled.

Of the two remaining walls at either end of the chamber, one was stationary. A door in this stationary wall (an 81.3-cm-wide x 198.1-cm-high steel, insulated vault door; FireGuard M/N 7832R, Schwab Corporation, Cannelton, IN) allowed experimenters and subjects access to the chamber. In order to both minimize movement of the door and seal in pressure waves resulting from sound emission, foam weather stripping (Thermwell Products Company, Peterson, NJ) was attached to the three edges of the door and a rubber threshold seal was installed on the chamber floor so that it butted against the door's bottom edge.

In contrast, the wall opposite that with the vault door was moveable. This "tuning" wall could be moved along the length of the chamber allowing the formation of standing waves within the chamber in the range of approximately 10 to 30 Hz (see below for more details). The tuning wall moved on twelve 15.2-cm-diameter steel wheels. The wheels were in sets of two, with three two-wheel sets attached on either side of the wall. Each set rested on and could move

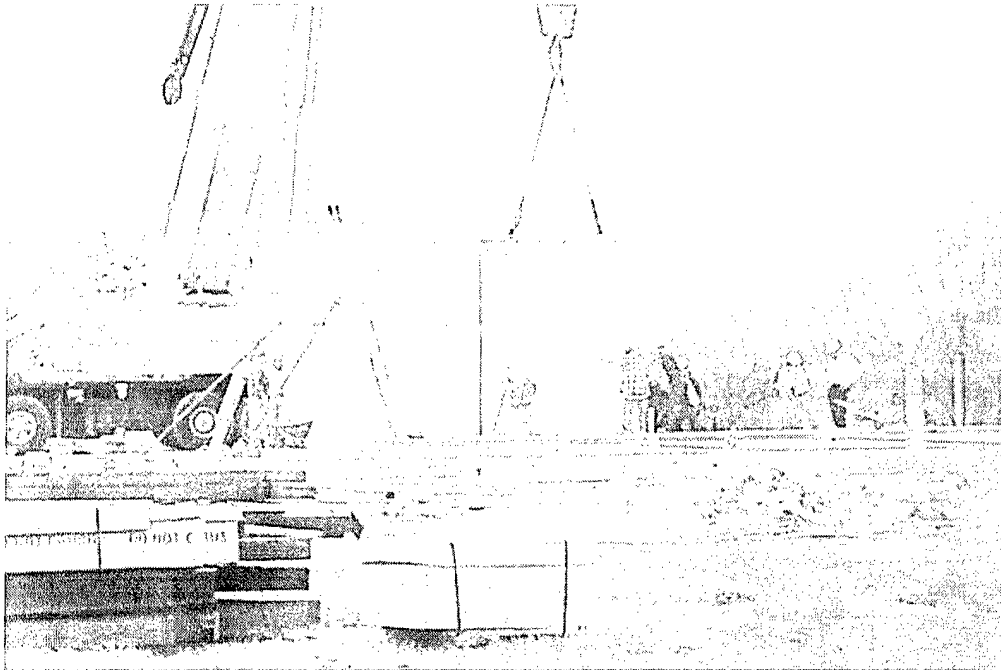

Figure 3. Installation of the reinforced concrete wall panels of the chamber.

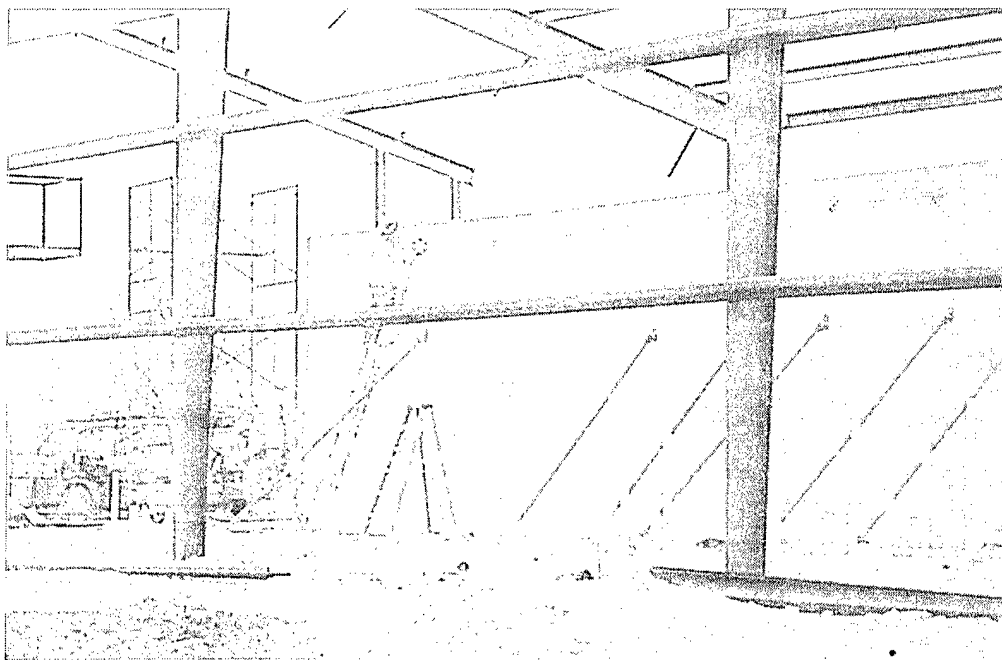

Figure 4. Securing the ceiling panels to the walls of chamber. (Note the framing for the metal building that will protect the chamber from the weather.)

along one of three rails (20.3 cm x 20.3 cm "H" beams, 1.3 cm thick) embedded in the concrete floor of the chamber. Wall movement was powered by a 0.75-horsepower, 1750 maximum rpm, DC electric motor along with a variable speed controller (M/N's CDP3440 for motor and BC140-FBR for controller, Baldor Electric Company, Fort Smith, AK). Four additional 12.7-cm-diameter rubber wheels, two attached to either side of the tuning wall, were in contact — not

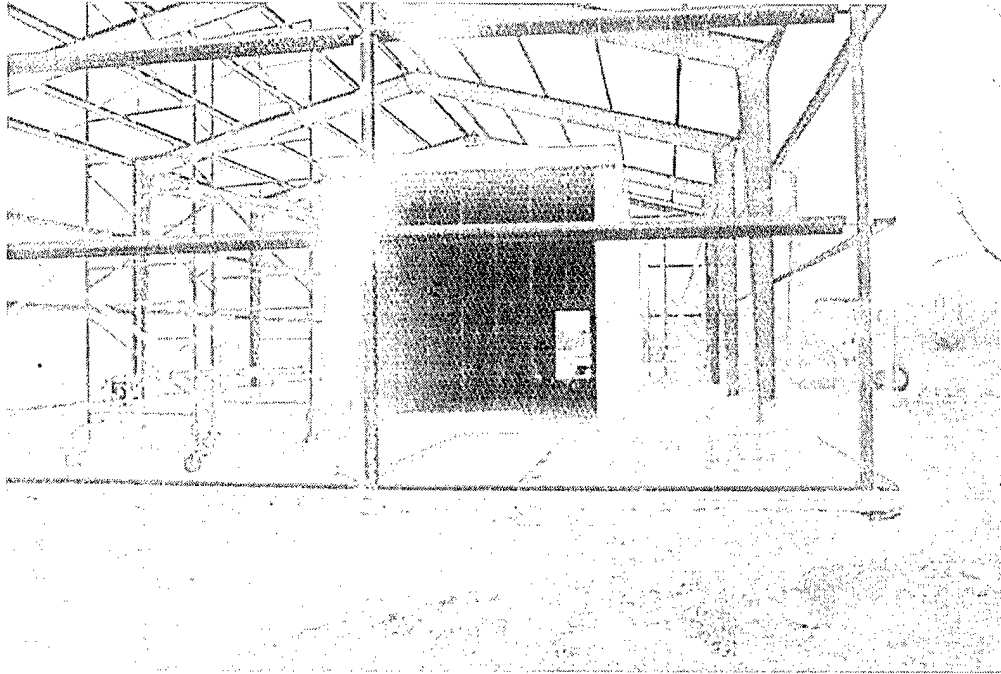

Figure 5. View of the erected chamber from the side where the tuning wall will be inserted. (Note the opening on the far end of the chamber where the safe door will be installed.)

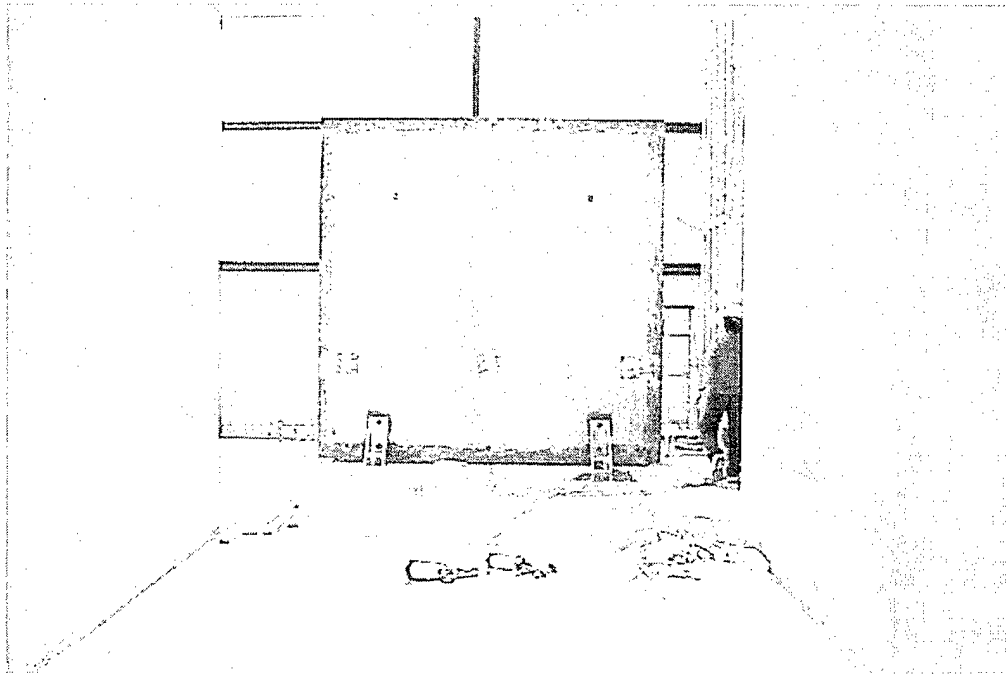

Figure 6. View of the tuning wall at the far end of the chamber prior to the wall's completion and insertion into the chamber.

with the floor of the chamber — but with the side walls. The purpose of these “outrigger” wheels was to aid in keeping the tuning wall from shifting laterally as it was moved up and down the length of the chamber. Figure 6 shows the tuning wall prior to installation of the wheels and

positioning of the wall inside of the chamber. Figure 7 shows one set of steel wheels and an outrigger wheel. Figure 8 shows the DC motor and its controller.

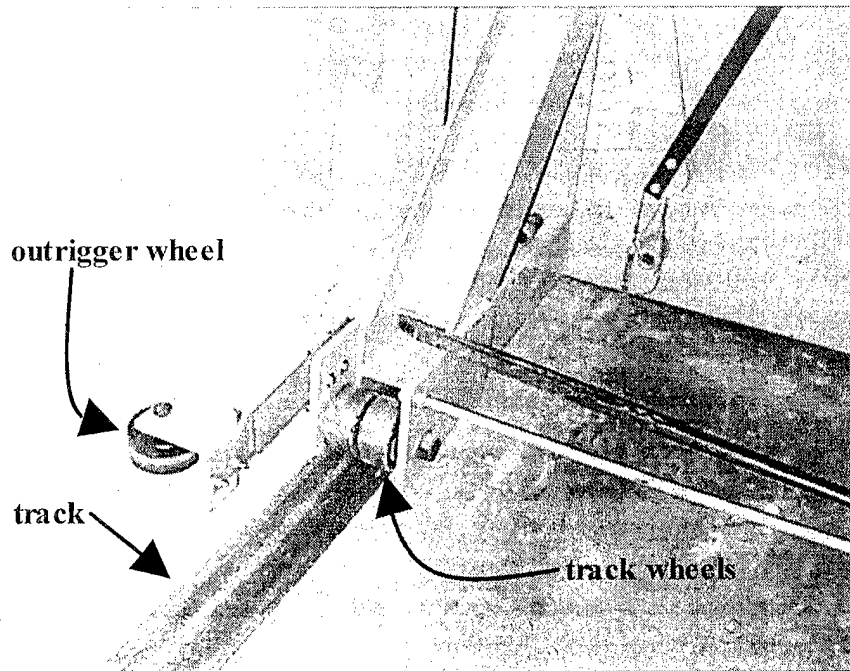

Figure 7. One set of track wheels and an outrigger wheel attached to the tuning wall, and one of the three tracks on which the tuning wall moved.

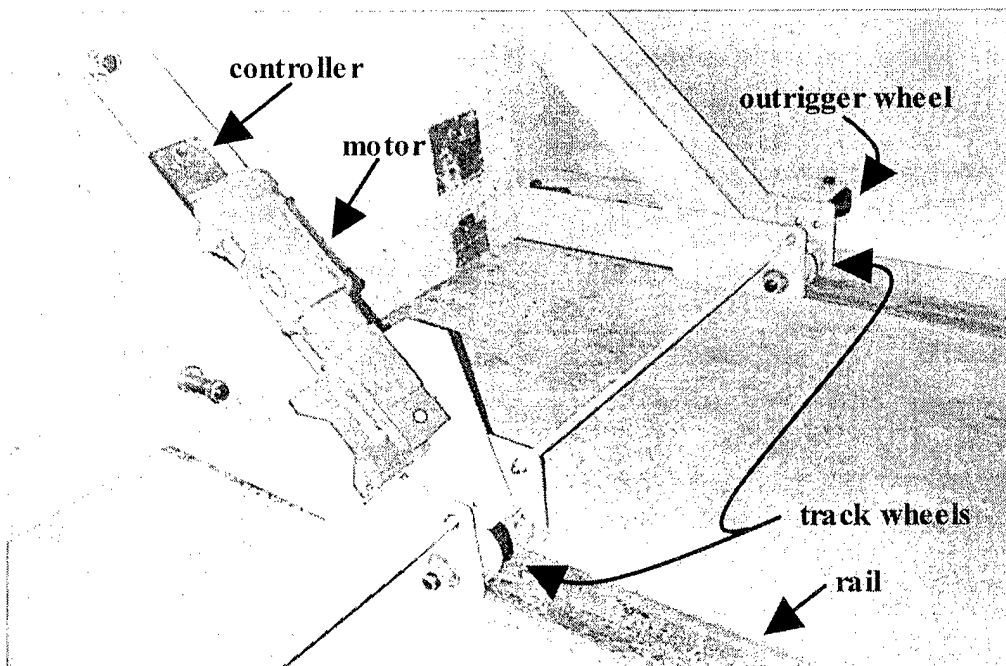

Figure 8. The motor and motor controller used to move the tuning wall.

Once the tuning wall was properly positioned within the reverberant chamber, the space between the outside edges of the tuning wall and inside walls of the chamber was sealed by

inflating a “bladder” made of black Pilovic reinforced with spiral synthetic yarn and then encased in yellow Pilovic (Spiraflex M/N 2700, Goodyear Tire & Rubber Company, Akron, OH). The bladder was approximately 16.5 cm in diameter (when fully inflated) and lay inside of a 20.3-cm-wide channel that was formed in part by the 20.3 cm x 20.3 cm “H” beams (1.6 cm thick) that comprised the outer edges of the tuning wall. During experimental exposures and acoustic measurements, the bladder was inflated to approximately 95-105 kPa utilizing a 0.5-horsepower, 17.6-liter compressor (Craftsman M/N 919-163550, Sears, Roebuck and Company, Hoffman Estates, IL). (The bladder was rated for a maximum pressure of 1.03 MPa.) Prior to moving the wall, the bladder was deflated and pulled away from the inside chamber walls using a multiple-point cable tensioner. Figure 9 shows the bladder being installed inside the channel during the construction phase of the tuning wall.

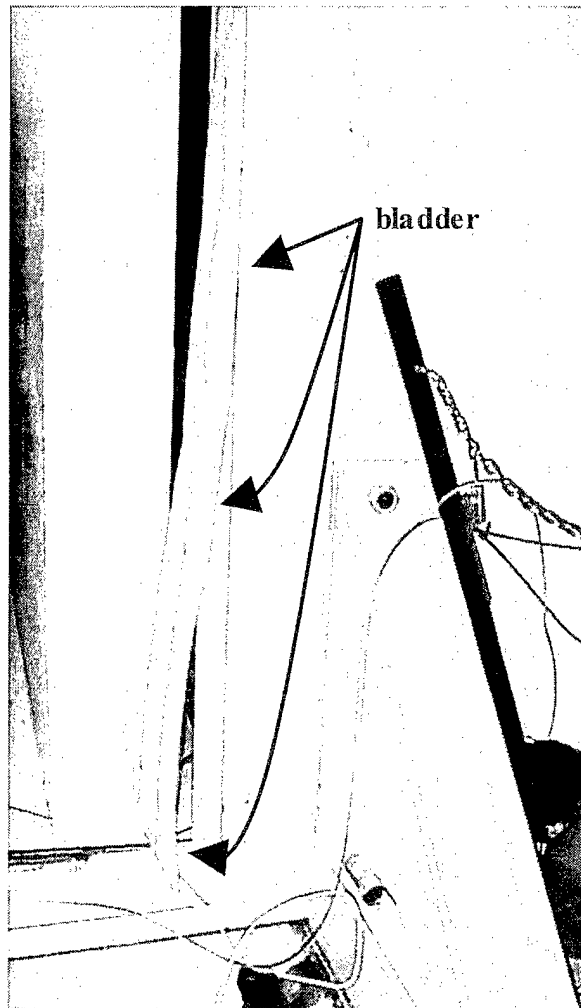

Figure 9. The uninflated bladder used with the tuning wall.

As noted above, by moving the wall to specific distances within the chamber, it was possible to tune the chamber to a specific frequency. For example, if the wall were positioned at the point corresponding to 10 Hz, when the chamber was subsequently energized at that frequency, a standing wave of that frequency would develop within the chamber. A standing wave would

also develop when the chamber was energized at the second and fourth harmonics (in this example, 20 and 40 Hz, respectively).

More specifically, the position of the tuning wall was determined thusly. The velocity of sound waves, s , in a gas is given by Equation 1.

$$s = \sqrt{\frac{\gamma \cdot P}{\rho}}, \quad (1)$$

where γ is a constant that depends on the gas (for air it is equal to 1.4), P is the ambient pressure in N/m^2 , and ρ is the density of the gas in kg/m^3 . At standard conditions (temperature 0°C and pressure of $1.013 \times 10^5 \text{ N/m}^2$), the speed of sound is 331.5 m/sec. As temperature increases, the speed of sound increases at a rate of 0.6 m/sec for each degree above 0°C . Taking into account the increase in the speed due to temperature, the speed of sound in air, s , is given by Equation 2.

$$s = \{331.5 + [0.6 \times (t - 0)]\}, \quad (2)$$

where t is the current temperature in $^\circ\text{C}$. For example, if the ambient temperature is 21.1°C (70°F), the equation above becomes:

$$s = [331.5 + (0.6 \times 21.1)]. \quad (3)$$

That is, the speed of sound in air at 21.1°C is 344.2 m/sec.

The dimensions of the chamber (primarily length) determine the frequencies for which standing waves can be produced. The fundamental resonant frequency, f , of a room or enclosure with parallel surfaces is defined by Equation 4.

$$f = \frac{s}{2L}, \quad (4)$$

where s is the speed of sound in air in m/sec at a given temperature and pressure and L is length of the enclosure in m. Using Equation 4, one can determine where to place the movable door to tune the chamber to a desired frequency. For example, to tune the chamber to a fundamental frequency of 24 Hz, the length of the room needs to be:

$$L = 344.2 / (2 \times 24) = 7.2 \text{ m}. \quad (5)$$

Practical construction considerations limited the length of the chamber to approximately 18.5 m, yielding a lowest achievable fundamental frequency of approximately 10 Hz. The highest possible fundamental frequency produced by moving the wall inward to the end of its track was approximately 24 Hz.

Sound Generation. The resonant chamber was energized by four “subwoofer” speakers (HydroSonic Interactive Bass Sound System, M/N HS 12, Sound Related Technologies [SRT],

Virginia Beach, VA). The output of most commercially available subwoofers is linear between 20 and 200 Hz, showing a sharp roll-off below 20 Hz and above 200 Hz. In contrast, the output of the SRT speaker shows minimal roll-off down to 6 Hz (the effective range of the speaker is 6 to 125 Hz). This is due to the unique construction of the speaker cabinet. Each cabinet contains two 29.3-liter, water-filled bladders that help couple the infrasound produced by the speaker to the air. One half of a typical SRT speaker cabinet is shown schematically in Figure 10. Each half of a SRT cabinet consists of two chambers, one above the other, separated by a common horizontal wall. A 12-in (30.5-cm) dual-coil, subwoofer driver (M/N SRT-15, Sound Related Technologies, Virginia Beach, VA) is mounted on and sealed to this common wall. The top chamber is airtight and contains a water-filled bladder. The fluid-filled bladder is mechanically coupled to walls of the top chamber, which are coupled with the exterior of the enclosure. A flexible baffle (made of Lionite, Georgia Pacific, Atlanta, GA) supports the fluid-filled bladder. The distance from the common wall to the baffle/fluid-filled bladder (indicated by dimension line l_z in Figure 10) should be approximately one half the diameter of the loudspeaker, d .

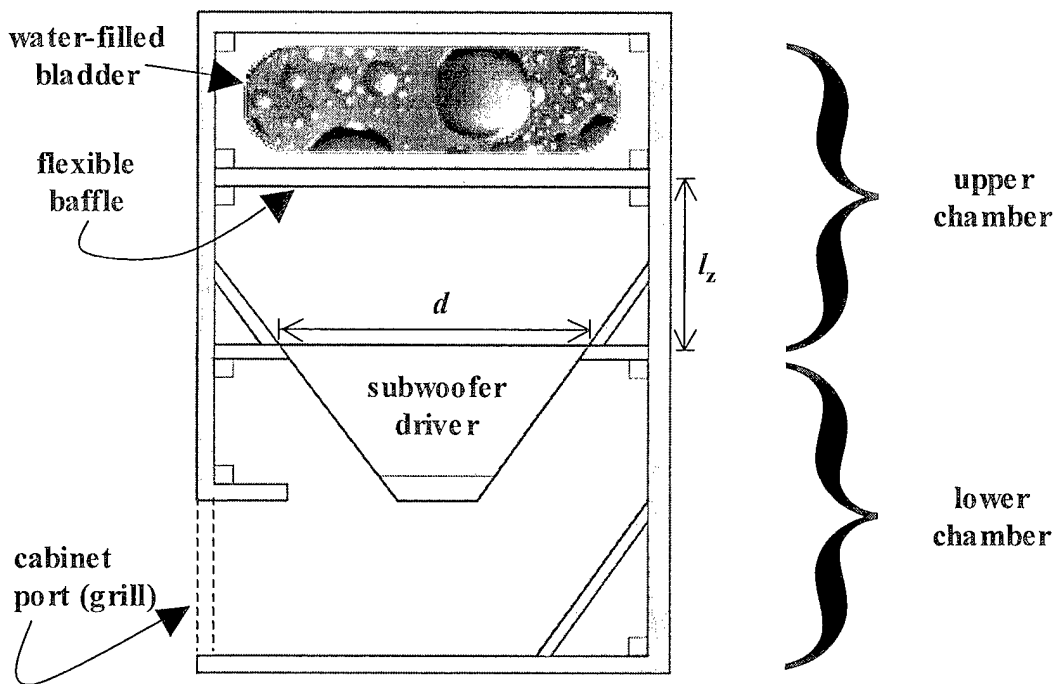

Figure 10. Schematic view of one half of a speaker cabinet designed by Sound Related Technologies. (Not drawn to scale.)

When the flexible cone of the subwoofer driver moves, it generates sound pressure waves of equal and opposite magnitude in both the upper and lower chambers. The waves pass through the baffle and impinge on the underside of the bladder and are, in turn, transmitted through the water. Since the bladder is in contact with the walls of the upper chamber, the sound pressure is coupled to these rigid radiating surfaces. Some of the sound pressure is reflected back towards the subwoofer driver causing a relative damping effect in the area of the upper chamber below the flexible baffle. The flexible baffle and the water-filled bladder, because they are flexible and compressible in nature, tend to act as a complex spring-like system, oscillating in a manner that

“broadens” the excitation frequency. This, coupled with the relatively large mass of the radiating surface (i.e., the rigid enclosure), tends to provide a relatively “full” sounding of low frequencies. This can be described mathematically by examining the resonant frequencies of the enclosure using the following equation:

$$f_{xyz} = \frac{1}{2} v \sqrt{\left(\frac{n_x}{l_x}\right)^2 + \left(\frac{n_y}{l_y}\right)^2 + \left(\frac{n_z}{l_z}\right)^2}, \quad (6)$$

where v is the speed of sound in air, n_x , n_y , and n_z are integers (i.e., 0, 1, 2, 3, ...), and l_x , l_y , and l_z are the linear dimensions of the enclosure on the x, y, and z axes. But, since the strongest forces acting on the bladder are in the vertical direction (i.e., the force of gravity and the upwardly-directed sound pressure waves), it is only necessary to look at the resonant frequencies in the vertical (or z) axis. Thus, Equation 6 simplifies to:

$$f_z = \frac{1}{2} v \sqrt{\left(\frac{1}{l_z}\right)^2} = \frac{v}{2l_z}. \quad (7)$$

Thus, when the speaker is energized, the dimension l_z oscillates over a small range of distances centered about the dimension l_z . The resonant frequency f is modulated over a small range of resonant frequencies centered about f . The wooden pieces at the ends of the dimension line labeled “ d ” act as extensions of the loudspeaker and prevent “gathering” of low frequencies in the lower corners of the upper chamber. The lower chamber has a grill-covered port that is open to the environment. The maximum intensity of the two halves of a single subwoofer cabinet taken together is 135-136 dB at 32 Hz.

The exterior dimensions of the four speaker cabinets differed slightly from one another. For two of the cabinets, the dimensions were: 127 cm high x 61 cm wide x 61 cm deep; for the remaining two: 129 cm high x 64 cm wide x 24 cm deep. The four SRT subwoofer cabinets were placed inside of the resonant chamber on a wooden stand (122 cm high x 244 cm wide x 61 cm deep), which placed the center of the speaker cabinets halfway between the floor and ceiling of the resonant chamber. The speakers were physically separated from the top of the wood stand by 3.5-cm-tall brass isolation cones. The platform was 152 cm from the front (non-moveable) wall of the chamber and 68 cm from each side wall. The speaker cabinet ports faced the non-moveable wall. Figure 11 shows the four SRT speakers mounted on the stand.

A software program — Cool Edit 96 (Syntrillium Software Corporation, Phoenix, AZ) — was used to generate a series of audio files used in driving the SRT speakers. All sound files were created using a 44.1-kHz sampling rate and had a 16-bit resolution. The output of each individual file was a sine wave at a specific frequency (e.g., 20 Hz). The output of the PC used in playing these audio files (400-MHz, dual-processor Pentium with 128 KB of RAM and a Sound Blaster AWE64 Gold audio card [Creative Labs Inc., Milpitas, CA]) was a signal that was approximately 1 volt peak-to-peak. This signal was fed into a Mackie 1202-VLZ PRO 12-Channel Mic/Line Mixer (Mackie Designs, Inc. Woodville, WA). The output of the Mackie

mixing board was fed into four QSC power amplifiers (M/N MX 2000a, QSC Audio Products, Inc., Costa Mesa, CA), one per SRT cabinet.

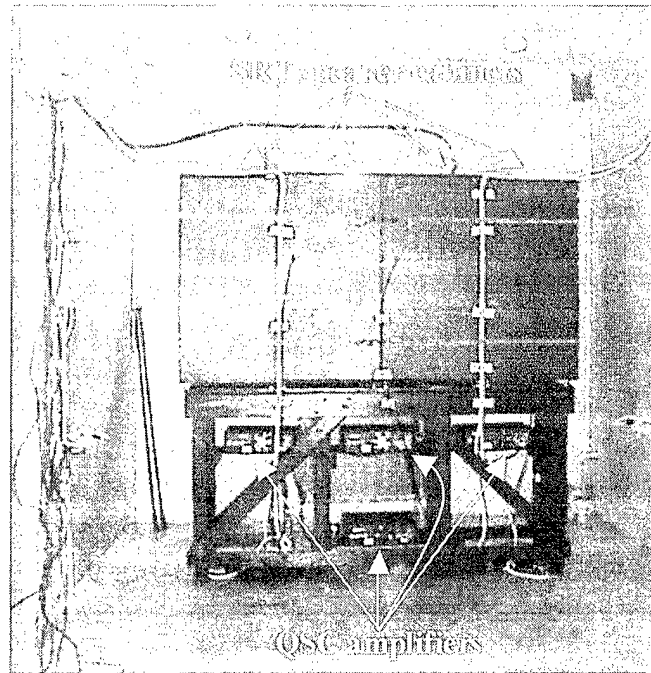

Figure 11. The four speaker cabinets mounted on a wooden stand inside of the resonant test chamber. Stereo amplifiers (one per cabinet) were situated on shelving immediately below the cabinets.

The four power amplifiers were connected in parallel with the mixer output. Each was operated in “bridged” mode, meaning that the amplifier feeds Channel 2 with an inverted signal from Channel 1. Thus, when one channel “pushes,” the other “pulls,” providing twice the voltage swing of a single channel. The result is that both channels can provide approximately three times the power to a single speaker load that a single channel does. The output of each bridged power amplifier was used to drive the two dual-coil subwoofer drivers in the corresponding SRT cabinet. The voice coils of each subwoofer driver were wired as shown schematically in Figure 12.

It should be noted that the primary purpose of the Mackie mixing board was to allow the relatively easy setting and measurement of the voltage level of the audio signal such that the SRT speakers could be maximally driven with little danger of damaging the subwoofer drivers. Target output voltage levels were calculated based on previously collected estimates of the subwoofer driver impedances at each frequency of interest. Figure 13 illustrates in part the procedure employed. At each frequency of interest (a) voltage was measured across a known-value resistor; (b) current across the resistor was calculated as $I_R = V_R / R$; (c) voltage across the driver was measured; (d) the driver impedance was calculated as $Z_S = V_S / I_R$; and (e) the target voltage out of the mixing board was calculated as $\sqrt{Z_s \cdot 750}$, 750 W per channel being the manufacturer’s estimate of amplifier output under a 2-ohm load.

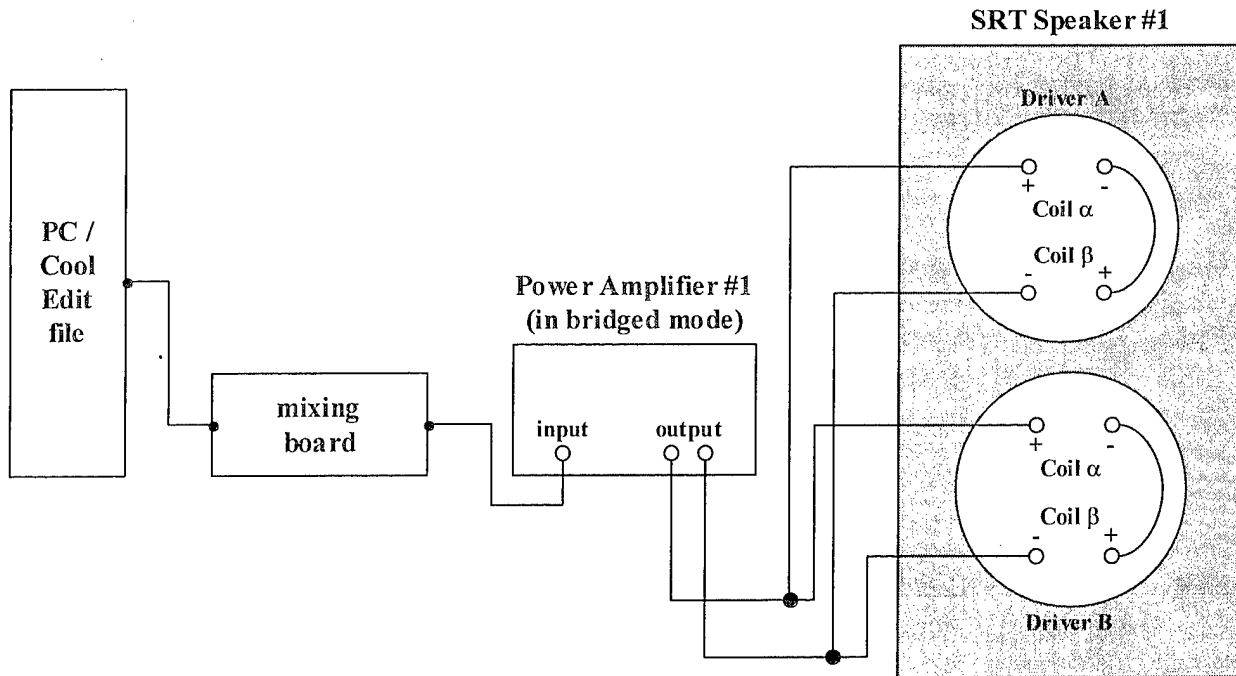

Figure 12. A simplified wiring schematic for production of audio signals (only depicts one amplifier and one speaker).

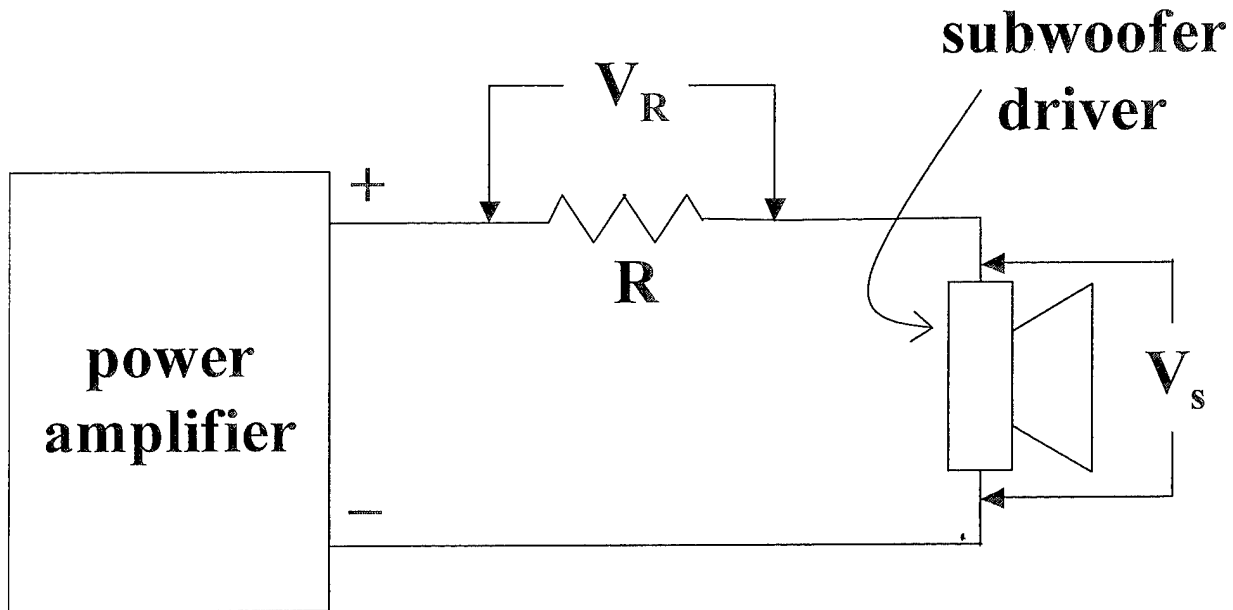

Figure 13. A schematic illustrating, in part, the procedure used in the measurement of speaker impedance.

Sound Measurement. A system was utilized that allowed description of the output of our high-intensity sources in terms of frequency, intensity, and duration. Acoustic intensity measurements were acquired via a Brüel & Kjær (B&K) microphone (M/N 4136A, Norcross, GA). The output of this microphone was amplified by a B&K microphone preamplifier (M/N 2670 or 2633) and a B&K Model 5935 Dual Microphone Supply. The output of the Dual

Microphone Supply was digitized, displayed, and analyzed by a program written in-house in LabVIEW (National Instruments, Austin, TX). This LabVIEW application displayed the collected acoustic data in both (a) the time domain and (b) the frequency domain (amplitude [in dB SPL] versus frequency) using the Fast Fourier Transform (FFT) method. The program was compiled with Version 5.1 of the LabVIEW compiler and ran on a 350-MHz Pentium II PC with a National Instruments PCI-4551 dynamic signal acquisition board. The microphones, amplifying circuits, and LabVIEW FFT program were calibrated prior to and immediately following each experimental session using a B&K Sound Level Calibrator (Model 4231), which produced a 1-kHz tone at 94 or 114 dB. The calibrator conformed to standards defined by the National Institute of Standards and Technology.

RESONANT CHAMBER ACOUSTIC MAPPING

In this phase of the project, the chamber tuning wall was moved to various locations designed to achieve standing waves at specific frequencies when the chamber was energized with acoustic signals of different frequencies. The amplitude of these signals was then measured at a number of locations inside of the chamber. The outcome of this measurement process determined, in part, the placement of apparatus inside of the resonant chamber during the behavioral experiments that were subsequently conducted.

Apparatus

For this phase of the project, the equipment employed (i.e., the chamber itself, sound generation and sound measurement equipment, etc.) is described in detail in the *General Methods and Procedures* section.

Procedure and Data Analysis

Acoustic mapping of the resonant chamber can be summarized as a 4 (position of chamber tuning wall) x 3 (audio signal frequency) x 2 (chamber door open vs. closed) design. More specifically, the resonant chamber was acoustically mapped with the tuning wall positioned to create standing waves at four fundamental frequencies: 10, 12, 15, and 20 Hz. At each of these four positions, the speakers were energized with three sinusoidal signals of differing frequencies. The frequency of the first signal was the same as the tuned frequency of the chamber. The frequency of the second signal was twice that of the tuned frequency. Finally, the frequency of the third was four times that of the tuned frequency. For example, in the case where the chamber was tuned to 10 Hz, the chamber was acoustically mapped using three audio signals: sinusoidal signals of 10, 20, and 40 Hz driving the SRT speakers. In addition, for each of the tuning wall position x audio signal factorial combinations, acoustic measurements were made with the door to the chamber open and with the door closed.

For each of the factorial combinations enumerated a series of acoustic measurements were made. For each measurement, one of the sinusoidal signals energized the four SRT speakers. Input signal amplitude (as measured coming out of the mixing board) was set as described in the *General Methods and Procedures* section. The output signal (i.e., the pressure waves emitted by

the SRT speakers inside of the chamber) was measured via the B&K microphone and its associated hardware and software (see *General Methods and Procedures* for details). For each measurement, an FFT was generated; the peak amplitude (in dB) was recorded along with the frequency where this peak occurred. In rare cases the frequency of the primary peak deviated by more than 0.05 Hz from the frequency of the input signal; such cases were always deemed to be the result of operator or equipment error and the measurement was repeated. Signal duration was either 8.192 s or 16.834 s. (The choice of signal duration was a matter of convenience; this parameter had no detectable effect on measured amplitude or frequency of the resulting pressure waves inside the chamber.) Placement of the B&K measurement microphone inside of the resonant chamber varied as a function of distance to the SRT speakers. That is, an imaginary line was drawn down the center of the chamber (from the speaker cabinets to the tuning wall). Microphone placement along this center line was in 1-m increments. That is, for Measurement 1 the microphone was positioned 1 m from the speaker cabinets; for Measurement 2 it was 2 m from the speaker cabinets, and so on. The height of the microphone was constant for all measurements at 1 m above the floor (the approximate location of one of the subjects used in the behavioral studies to be described).¹

Results and Discussion

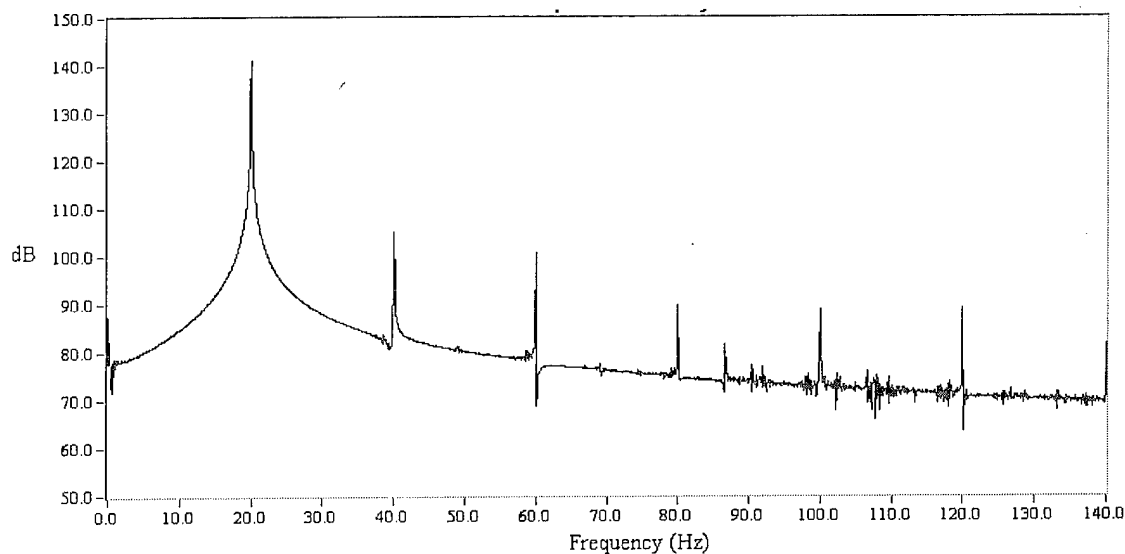

Figure 14. A Fast Fourier Transform of a 20-Hz sinusoidal signal measured at 6 m from speakers in the test chamber when tuned at 10 Hz.

Figure 14 shows a representative FFT. For this particular FFT, the resonance of the chamber was set at 10 Hz, the chamber was energized with a 20-Hz signal, and the measurement

¹ Only measurements made along this center line and at the 1 m height are included in this report. However, it should be noted that measurements at various locations led to the conclusion that distance from the front of the speaker was the primary determinant of speaker amplitude. As an example, if we were to consider the set of all measurements made at 5 m from the speakers, where microphone placement varied as a function of height and placement along the imaginary line perpendicular to the center line, the range of the resulting amplitudes would be no more than 1 dB.

microphone was situated 6 m from the SRT speakers. The FFT reveals a peak amplitude of 141.2 dB at 20.0 Hz.

Figure 15 summarizes all of the FFTs of 10-, 20-, and 40-Hz signals (recorded at distances of 1 to 15 m from the speakers) when the chamber was tuned to 10 Hz.

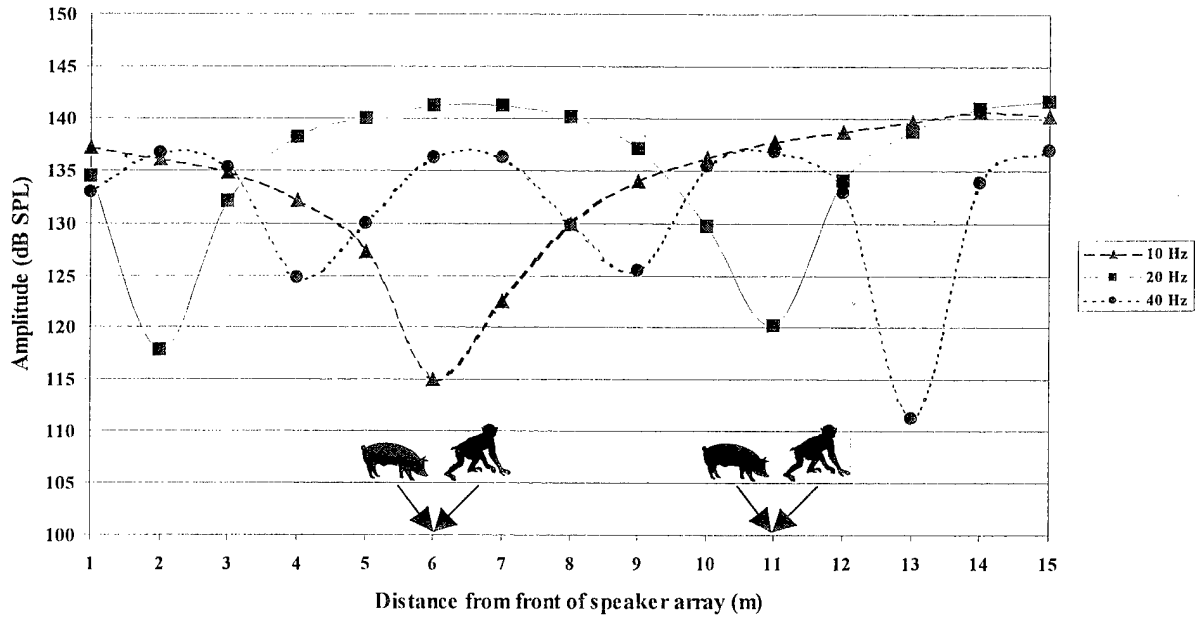

Figure 15. Amplitude of 10-, 20-, and 40-Hz signals within the resonant chamber tuned to 10 Hz. Pig and monkey icons indicate subject locations.

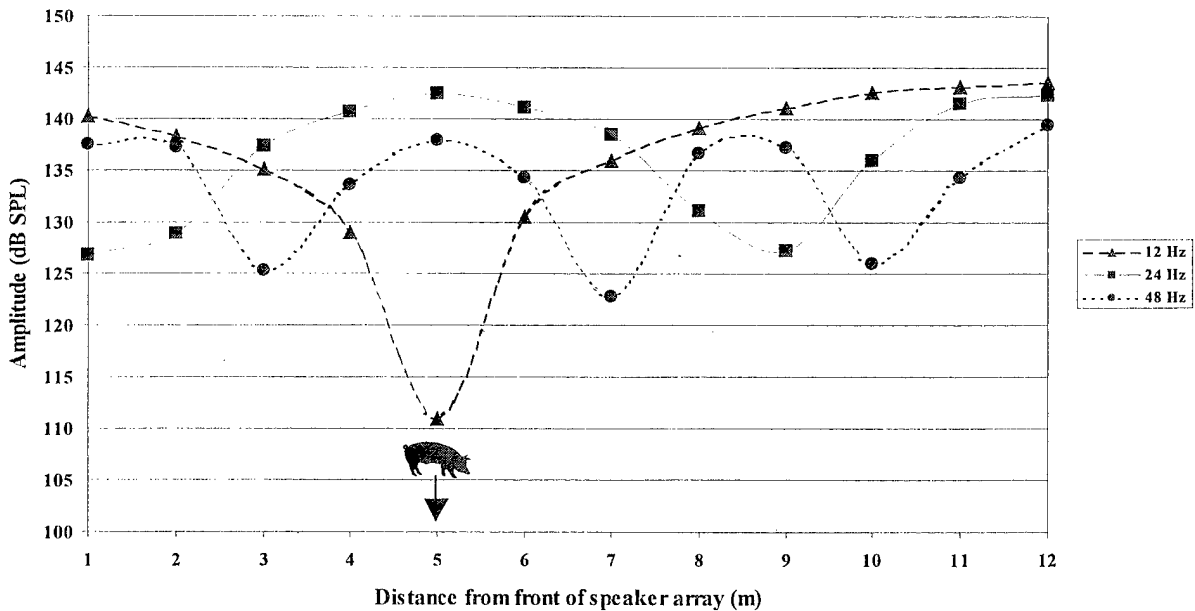

Figure 16. Amplitude of 12-, 24-, and 48-Hz signals within the resonant chamber tuned to 12 Hz. Pig icon indicates subject location.

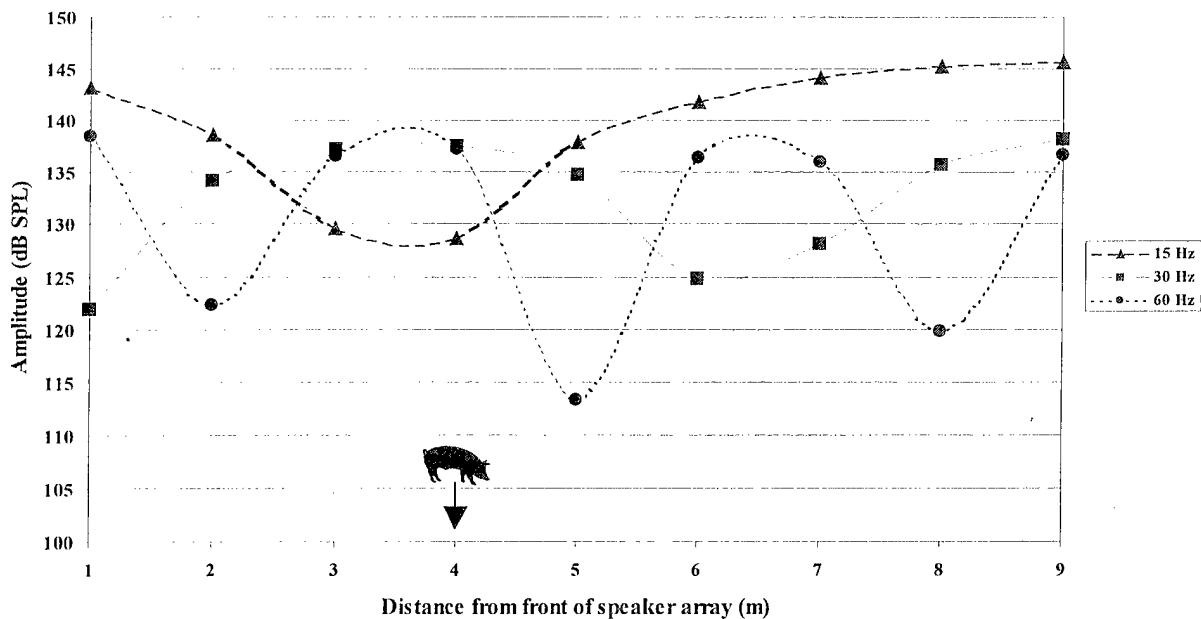

Figure 17. Amplitude of 15-, 30-, and 60-Hz signals within the resonant chamber tuned to 15 Hz. Pig icon indicates subject location.

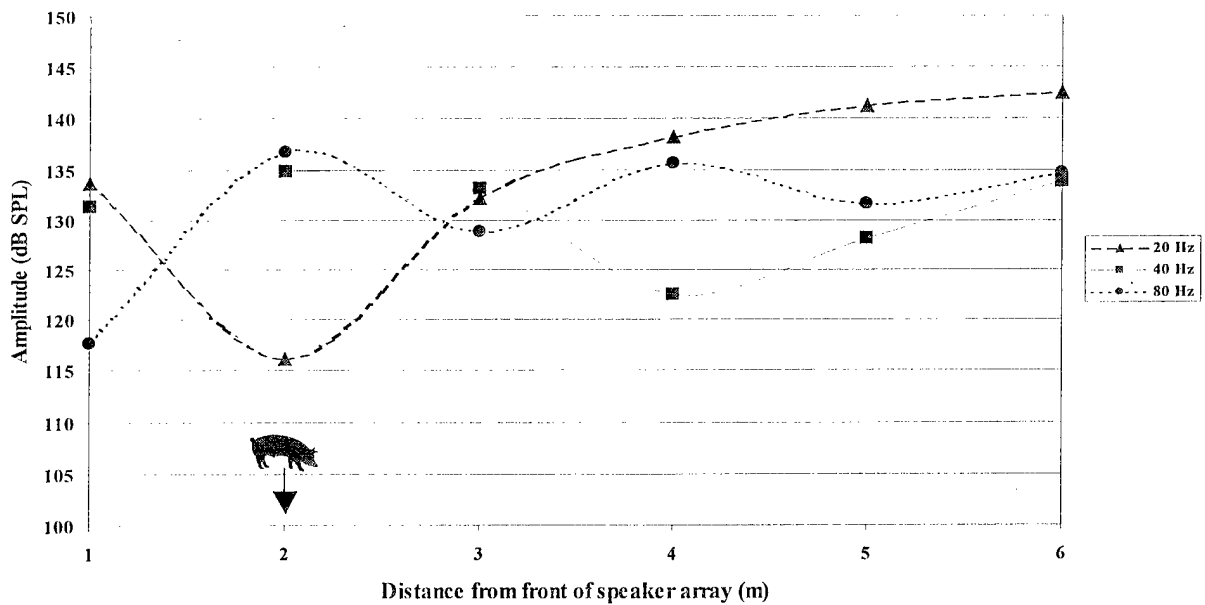

Figure 18. Amplitude of 20-, 40-, and 80-Hz signals within the resonant chamber tuned to 20 Hz. Pig icon indicates subject location.

Figure 16 summarizes all of the FFTs of 12-, 24-, and 48-Hz signals (recorded at distances of 1 to 12 m from the speakers) when the chamber was tuned to 12 Hz. (Note that as the chamber is tuned to progressively higher frequencies, the length of the chamber decreases, and hence the number of measurement locations also decreases.)

Figure 17 summarizes all of the FFTs of 15-, 30-, and 60-Hz signals (recorded at distances of 1 to 9 m from the speakers) when the chamber was tuned to 15 Hz.

Finally, Figure 18 summarizes all of the FFTs of 20-, 40-, and 80-Hz signals (recorded at a distance of from 1 m to 6 m from the speakers) when the chamber was tuned to 20 Hz.

In sum, a consideration of Figures 15-18 suggests that the performance characteristics of the chamber are approximately in accord with prior expectations. Specifically, a comparison of each of Figures 15-18 with Figure 1 (which depicts the expected standing wave patterns for the fundamental, second, third, and fourth harmonics) shows that the obtained waveforms approximately resemble the expected ones. For example, Figure 1 shows that in the case of the fundamental, the period of the waveform is twice the chamber length; this is also true for the fundamentals for each of Figures 15-18 (10, 12, 15, and 20 Hz, respectively).

All of the measurements depicted in Figures 15-18 were obtained with the chamber door closed. In order to obtain a rough measure of the gain (or Q) resulting from the tuned, resonant, reverberant chamber, the foregoing measurements were also obtained with the door open, thus allowing the chamber to act as a ported pseudo-Helmholtz resonator. (Helmholtz resonators are, in general, tuned sound absorbers.) Figure 19 shows the results of both the closed and open door measurements for the four tuned frequencies (collapsed over all of the measuring positions). For example, when the chamber was tuned to 10 Hz and energized at 10 Hz, a gain of 31.6 dB resulted from the tuned cavity. Conversely, when the cavity was tuned to 10 Hz and excited at 40 Hz, the tuned cavity was 3.6 dB lower than the un-tuned cavity.

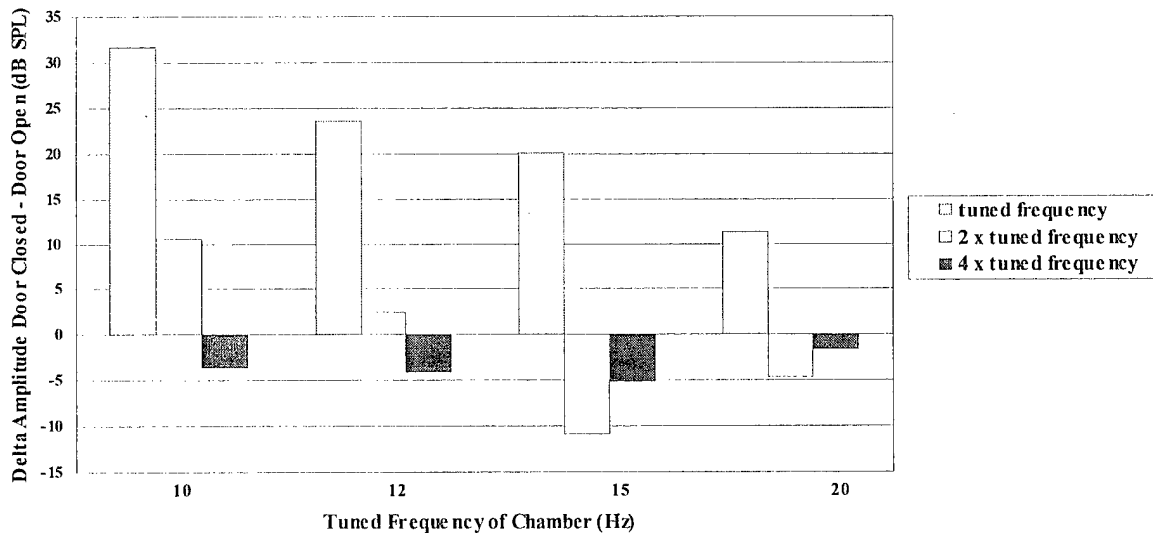

Figure 19. Resonance chamber gain as a function of four tuned frequencies.

In general, Figure 19 shows higher gains when the chamber was energized with an audio signal matching the tuned frequency of the chamber (as expected). Further, this gain diminished

as the chamber was tuned to higher frequencies. For example, the Q when the chamber was tuned to 10 Hz and energized at 10 Hz was 31.6 dB; in contrast, the Q when the chamber was tuned to 20 Hz and energized at 20 Hz was 11.3 dB. Further, gains decreased sharply when the tuned chamber was energized with a signal that was a second or fourth harmonic of the tuned frequency. Indeed, in the case of the fourth harmonic, all Q values were negative (i.e., amplitudes when the chamber door was open exceeded those obtained when the door was closed).

EFFECTS OF SRT SPEAKER OUTPUT ON SWINE OPERANT BEHAVIOR

Subjects

Minipigs (*Sus scrofa*) were supplied by Charles River Laboratories (Wilmington, MA). They were individually housed in pens (3.0 m long x 1.0 m wide x 2.0 m high) with cement floors. The room temperature was maintained at 24 ± 2 °C with a 12:12 hour light:dark cycle. Water was always available ad libitum in their pens. Except during testing, approximately 1.0 to 2.3 kg of Purina Mills Minipig HF Grower (Purina Mills, Inc., St. Louis, MO) was provided to each subject in the morning and afternoon. This diet was occasionally supplemented with fresh fruit. Beginning one day prior to testing, food was withheld from subjects and was not made available again until immediately after testing. One subject weighed approximately 74 kg during the course of testing; the other weighed approximately 81 kg.

Apparatus

The swine were trained using the method of successive approximations to press a panel (e.g., Sherry et al., 1994). The panel-press device, constructed by Whitmore Enterprises (San Antonio, TX, Model WE 1001), consisted of a Plexiglas supporting rectangular plane (133 cm long x 60 cm high) and a Plexiglas press panel (16.5 cm long x 16 cm high) that was mounted 36 cm from the left edge of the supporting plane and 27 cm above the bottom of the plane. The press panel was hinged along its top edge. Nylon screws were attached to the back surface of the press panel approximately 1 cm from its bottom edge and extended (via small holes) back into the supporting rectangular plane. When the press panel was fully pressed, one of the nylon screws struck and closed a single-pole, double-throw, short-roller microswitch (Selecta Switch, Tehachapi, CA, Model 11A 125/250/277VAL High Force [0.8 oz]), thereby defining a panel-press response. Following completion of a panel press, a small spring around one of the screws caused the panel to return to its normally open position. When the subject completed a sufficient number of responses, approximately 20 g of cracked corn (Allied Feeds, San Antonio, TX) was deposited into a food well (16.5 cm long x 7.5 cm high x 20 cm deep) mounted on the front of the support plane (5 cm from its right edge). Delivery of food and recording of panel-press responses were controlled by a Universal Environment Interface (E91-12), an Environment Interface Control (S91-12), a Retriggerable One Shot (S52-12), and a Predetermining Counter (S43-30), all made by Coulbourn Instruments (Allentown, PA). Figure 20 shows the panel-press apparatus.

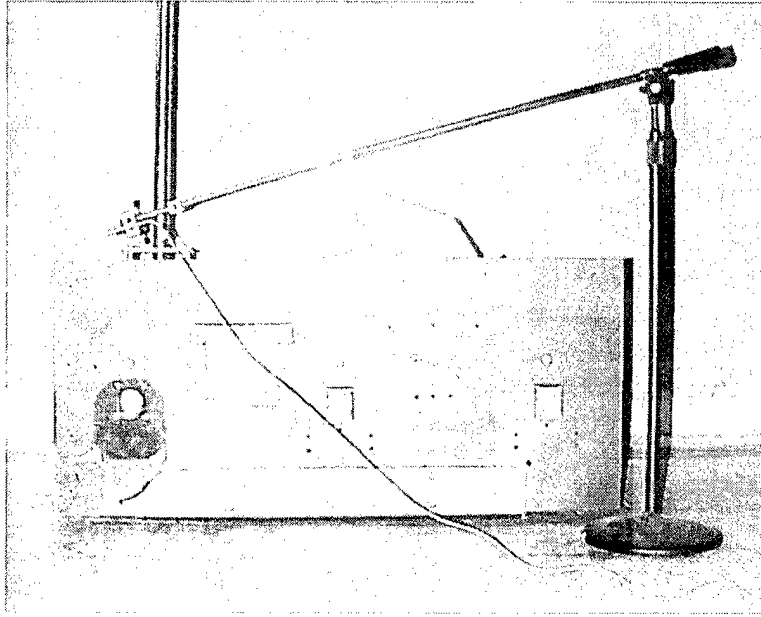

Figure 20. The panel-press apparatus used with swine subjects. (The figure also shows the measurement microphone.)

Procedure and Data Analysis

Pre-Exposure Panel-Press Training. Prior to testing with the SRT speakers, both subjects — 548 and 554 — had received extensive training with the panel-press apparatus. At the conclusion of training, both subjects pressed vigorously at a steady and reliable rate.

Exposure to SRT Speakers. Subjects received a series of daily exposure sessions in the resonant chamber during which the four SRT speakers were energized at different points in time while subjects were engaged in their panel-press task. The effect of the resulting pressure waves on subject operant behavior was recorded.

Three parameters varied over the series of exposure sessions: (a) the position of the tuning door, (b) the frequency of the audio signal output by the SRT speaker array, and (c) the position of the panel press apparatus within the resonant chamber. That is, during each session, the chamber tuning wall was in one of four positions: set to produce a standing wave with fundamental frequency of either 10, 12, 15, or 20 Hz (i.e., the same positions used during mapping of the chamber; see Figures 15-18). Further, during a given session, the chamber was energized with audio signals at three different frequencies: the fundamental frequency, the second and the fourth harmonics. (E.g., when the chamber was tuned to 10 Hz, audio signals of 10, 20, and 40 Hz were employed.) The “pig” icons in Figures 15-18 indicate the position of the panel press apparatus within the resonant chamber during each of the four wall positions. That is, the apparatus was located either 6 or 11 m from the front of the speaker array during the 10-Hz tuning sessions, and at 5, 4, and 2 m from the array during the 12-, 15-, and 20-Hz tuning sessions, respectively. The apparatus was situated at points within the chamber where the amplitude of at least one of the audio signals was at or near its maximum value. For example, in

the case where the tuning wall was set to 10 Hz, the amplitude of the 20-Hz at 6 m was near its maximum value (>140 dB; see Figure 15).²

The order in which the exposure sessions were presented was: (a) tuning wall set to 10 Hz, (b) tuning wall set to 12 Hz, (c) tuning wall set to 15 Hz, and (d) tuning wall set to 20 Hz. Within any set of sessions at a given tuning wall position, the presentation of the three signals of differing frequencies (viz., the fundamental frequency, the second and the fourth harmonics) was intermixed on a pseudorandom basis.

Each daily session proceeded as follows. A subject was introduced into the resonant chamber and led to the panel-press apparatus. For all of the daily sessions, the subject began panel pressing almost immediately. Once operant behavior commenced a "baseline" period of 2 to 4 min ensued during which the subject was free to panel press and no audio signals were presented. Operant behavior was reinforced on a FR 3 schedule (i.e., every third response was rewarded with approximately 20 g of cracked corn). Following this baseline period, the SRT speakers were energized with an audio signal of a specific frequency. The set of signals used were the same ones used in mapping the resonant chamber (see Figures 15-18). The duration of the audio signals varied somewhat (median = 61 s). This variability was primarily a function of concern over possible overheating of the audio equipment (specifically, the speaker coils).

Subjects experienced from 2 to 7 audio signals per daily session. This variation was primarily due to the differences in the time it took for the subject to become satiated (and hence cease panel pressing). A minimum of approximately 1 min separated sequential audio signals. No audio signals were introduced into the chamber until the subject was at the panel press apparatus either eating or pressing.

Two behavioral endpoints were measured: the effect of the audio signals on (a) consummatory behavior, and (b) escape behavior. A signal was classified as having an effect on consummatory behavior if the subject refrained from both panel pressing and eating at the feeder for the duration of the signal. A signal was classified as having an effect on escape behavior if, at any time during the presentation of the signal, the subject moved at least 1 m away from the apparatus and failed to return to the apparatus during the remainder of the presentation.

Results

Tables 1 and 2 summarize the effect of speaker output on subject escape and consummatory behavior, respectively. Because no differences between the 2 subjects were evident, both tables summarize the results collapsed over both subjects. In addition, no differences emerged between the two apparatus locations in the case of the 10-Hz tuning wall position (6 and 11 m; see Figure 15); thus, both tables collapse results over these two conditions as well.

² Initial sessions with the subjects, performed at the 10-Hz position of the tuning wall, indicated that subject behavior did not appreciably vary as a function of location of the apparatus within the chamber. Therefore, whereas subjects were tested at two locations during the 10-Hz tuning sessions, they were only tested at one location for all subsequent positions of the tuning wall (12, 15, and 20 Hz).

Table 1. Proportion of signals during which an effect on subject escape behavior was observed.

		Signal frequency (Hz)		
		Tuned frequency	2 x tuned frequency	4 x tuned frequency
Tuning position (Hz)	10	0.38	0.07	0.00
	12	0.00	0.00	0.00
	15	0.00	0.00	0.00
	20	0.00	0.00	0.00

Table 2. Proportion of signals during which an effect on subject consummatory behavior was observed.

		Signal frequency (Hz)		
		Tuned frequency	2 x tuned frequency	4 x tuned frequency
Tuning position (Hz)	10	0.50	0.13	0.00
	12	0.20	0.00	0.00
	15	0.00	0.00	0.00
	20	0.00	0.00	0.00

In sum, these results show only a minimal impact of infrasound and low sonic acoustic energy on subject behavior that rapidly dissipates with repeated exposures. Signal effects were confined almost exclusively to those sessions where the tuning wall was set to 10 Hz. For example, an effect on escape behavior appeared on 38% of sessions when the tuning wall was set at 10 Hz and the chamber was energized with a 10-Hz signal. However, because the 10-Hz tuning position sessions were the first to be conducted, it appears highly likely that these early effects constitute an evanescent startle-like response that rapidly habituates.

EFFECTS OF SRT SPEAKER OUTPUT ON RHESUS MONKEY BEHAVIOR

Subjects

Subjects were 2 rhesus monkeys (*Macaca mulatta*) acquired from the rhesus colony maintained at Brooks Air Force Base, TX. Monkeys were housed individually in standard stainless steel cages (77.5 cm high x 61.0 cm wide x 71.1 cm long). Room temperature was maintained at 24 ± 2 °C with a 12:12 hour light:dark cycle. Subjects were provided approximately 0.2 kg of Purina Mills Monkey Diet both in the morning and the afternoon. This was supplemented approximately twice a week with fresh fruit. Water was available ad libitum. One subject weighed approximately 9.5 kg during the course of testing; the other weighed approximately 10.5 kg.

Apparatus

The PEP is a continuous, compensatory-tracking task that has been extensively used in assessments of the effects of nerve agents and associated drugs, such as prophylactics, antidotes, and their combinations (Farrer et al., 1982; Blick et al., 1994). Performance on the PEP task measures fine motor control involved in joystick manipulation and the integrity of the complex sensorimotor system necessary for maintaining equilibrium and orientation in space. The neural

system for maintaining orientation/equilibrium is complex and highly integrated, involving several sensory inputs (vestibular, visual, and kinesthetic). Brain centers involved in integrating this sensory information include the cerebellum, sensory cortex, and nuclei of the thalamus, midbrain, and brainstem.

A subject performing in the PEP was seated in a restraint chair that rotated on the pitch axis about the subject's center of gravity. A computer (80286 PC with a DAS-8/AO data acquisition and control board [Keithley Instruments, Inc., Taunton, MA]) used a bounded stochastic process to generate random perturbations in pitch. If no monkey were present, there would be large variations in chair position, with a standard deviation of 12-15°. The subject's task was to manipulate a joystick control to compensate for these random perturbations. When the platform position deviated from the horizontal plane by more than 15°, the monkey received a mild electric shock delivered to the tail (100-ms duration, 1-Hz repetition rate, and 5-mA maximum current). A well-trained subject could reduce the standard deviation to 2-4° and receive few, if any, shocks (less than one per hour on average). Figure 21 shows a subject operating the PEP.

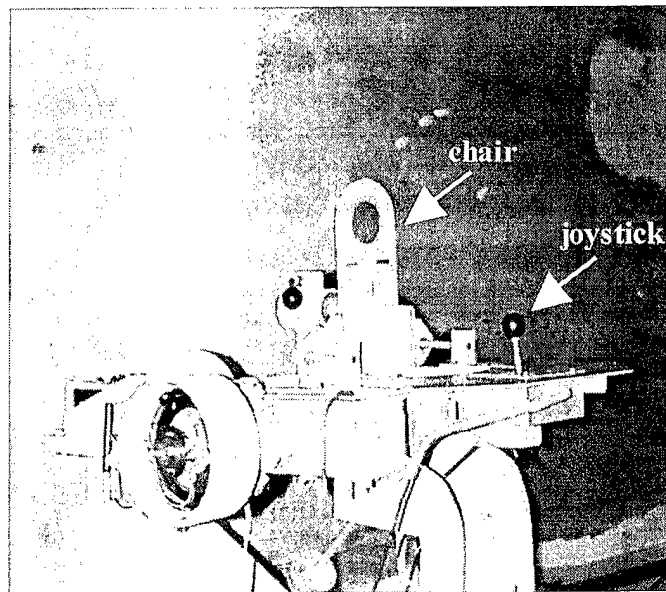

Figure 21. The Primate Equilibrium Platform inside of the resonant chamber.

Procedure and Data Analysis

Sessions in the PEP were 60 min in duration. For purposes of analysis, each 60-min session was subdivided into 72 epochs of 50 s. Shock frequency was recorded for each epoch. In addition, for each epoch, chair position (degrees deviation from the horizontal plane) was measured 10 times per second and these values were used to calculate mean chair position and the standard deviation of chair position for the epoch. Chair standard deviation during an experimental session in the PEP was compared with chair standard deviation during five baseline PEP sessions; that is, the standard deviation values from the baseline sessions for a given subject were used to determine the range of normal performance for that subject by the method of simultaneous tolerance limits (Lieberman and Miller, 1963). The method consists of fitting a line to the baseline performance values by the method of least squares. Residual variation about

the fitted line was used to generate simultaneous tolerance limits ($p = .99$, $\alpha = .01$). A performance decrement was defined as occurring when one or more standard deviation values from the experimental session exceeded the upper tolerance limit.

The rhesus subjects in the present experiments had extensive prior experience with the Primate Equilibrium Platform (PEP). Subjects received the five baseline PEP sessions over a period of 2 weeks. Subjects received the first of three 60-min experimental (exposure) PEP sessions approximately 48 hr after the last baseline session. The second experimental PEP session followed the first by approximately 24 hr; the third followed the second by an additional 96 hr.

The chamber tuning wall was set for 10 Hz for all three of the experimental sessions. For Session 1, the PEP was situated approximately 6 m from the front of the SRT speaker array. For Sessions 2 and 3, the PEP was located approximately 11 m from the speaker array. The PEP apparatus was situated at points within the chamber where the amplitude of at least one of the audio signals was at or near its maximum value. Thus, at 6 m the 20-Hz was near its maximum value; at 11 m both the 10- and 40-Hz signals were at or near their maximum values (see Figure 15). Subjects experienced six audio signals during the course of an experimental session. Signals were at either 10 Hz (the fundamental frequency of the chamber) or 20 Hz (the second harmonic). The presentation order of the six signals alternated as a function of frequency (i.e., ABABAB, where A represents one of the two frequencies, and B the other). For a given experimental session, one of the two subjects was presented the 10-Hz signal first, while the second subject was presented the 20-Hz signal first. Signals were all 50 s in duration so as to coincide with the onset and offset of one of the 72 50-s PEP epochs. Signals were presented during Epochs 6, 18, 30, 42, 54, and 66.³

Results

In overview, subject behavior inside of the resonant chamber was not substantially affected by the output of the SRT speakers. Figures 22 and 23 depict the PEP performance of the two subjects (510Z and 952Z, respectively) during the 72 epochs of the first exposure session. There were no decrements in PEP performance (i.e., the standard deviation of chair position did not exceed the 99% tolerance limit) during any of the 72 epochs; more importantly, there were no decrements during the 6 epochs during which a signal was present.

Figures 24 and 25 depict the PEP performance of the two subjects (510Z and 952Z, respectively) during the second exposure session. The performance of one of the two subjects, 510Z, was similar to that exhibited during the first test session; that is, PEP performance was within normal limits throughout the session (including those epochs during which an audio signal was present). In contrast, the PEP performance of 952Z exceeded the threshold defined by the 99% tolerance limit line for 29 of the 72 epochs (approximately 40%). However, the performance decrements are not correlated to any significant degree with the output of the speaker array, but instead occur throughout the session. Specifically, decrements appear during 4 of the 6 “signal” epochs, but also appear during 25 of the remaining 66 “non-signal” epochs.

³ Due to experimenter error, signals were presented during Epochs 7, 19, 31, 43, 55, and 67 during the second session for one of the subjects.

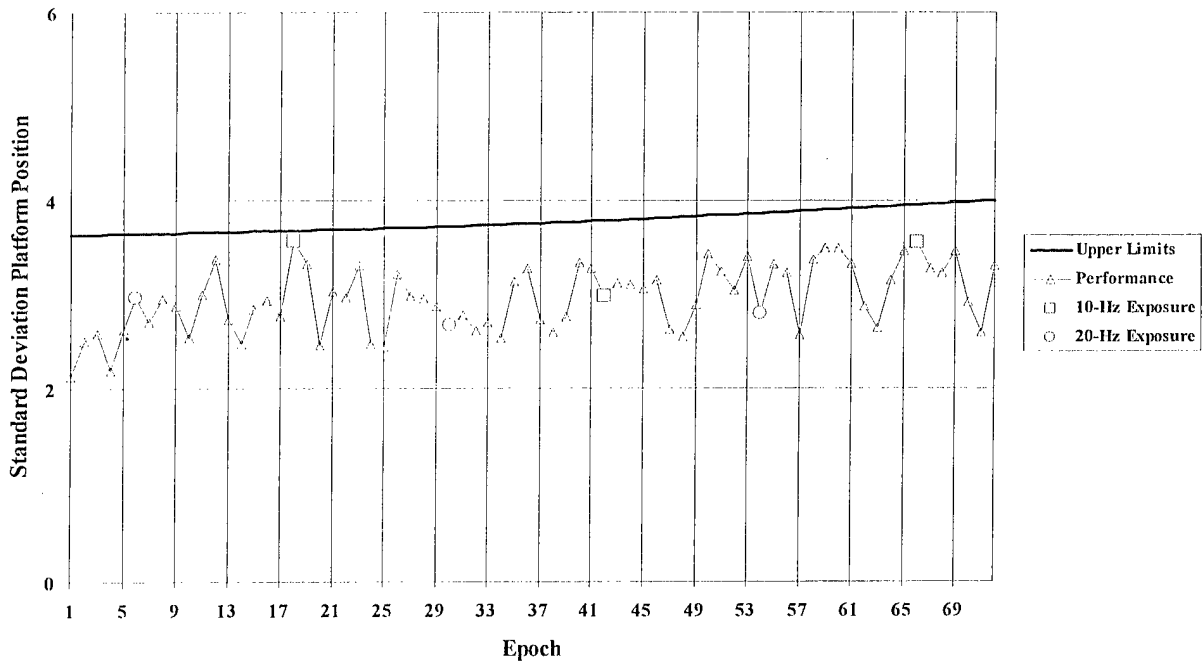

Figure 22. Performance of rhesus subject (510Z) on Primate Equilibrium Platform during first exposure session. (Square and circle symbols indicate the epochs during which the subject was exposed to 10- and 20-Hz signals, respectively.)

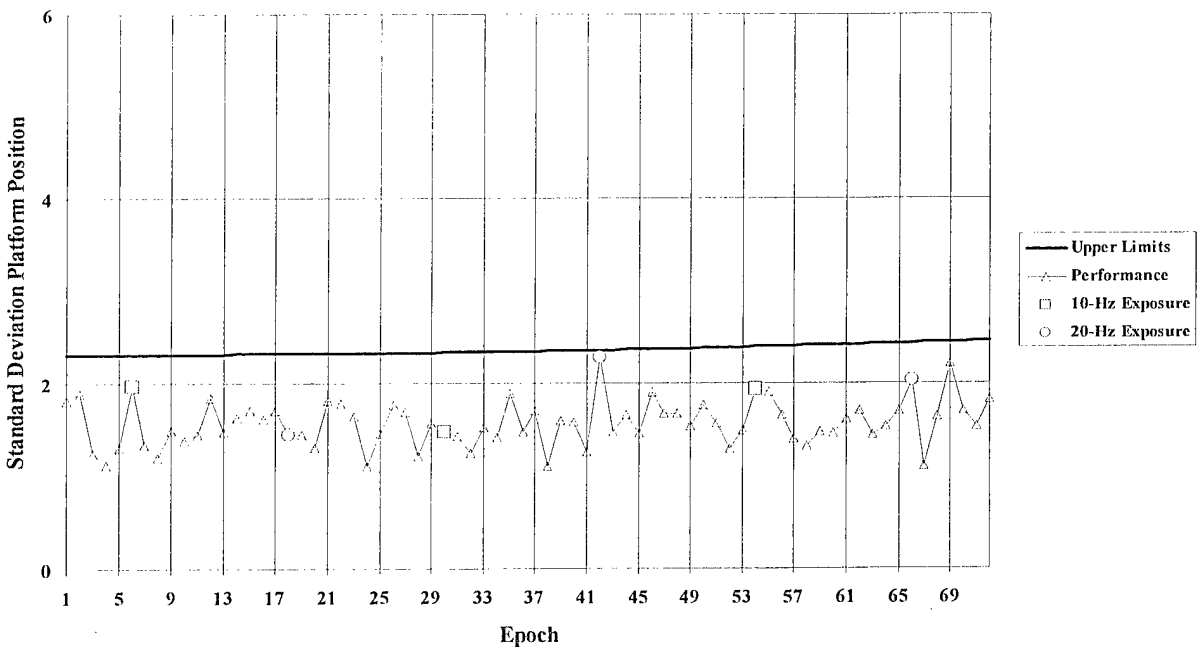

Figure 23. Performance of rhesus subject (952Z) on Primate Equilibrium Platform during first exposure session. (Square and circle symbols indicate the epochs during which the subject was exposed to 10- and 20-Hz signals, respectively.)

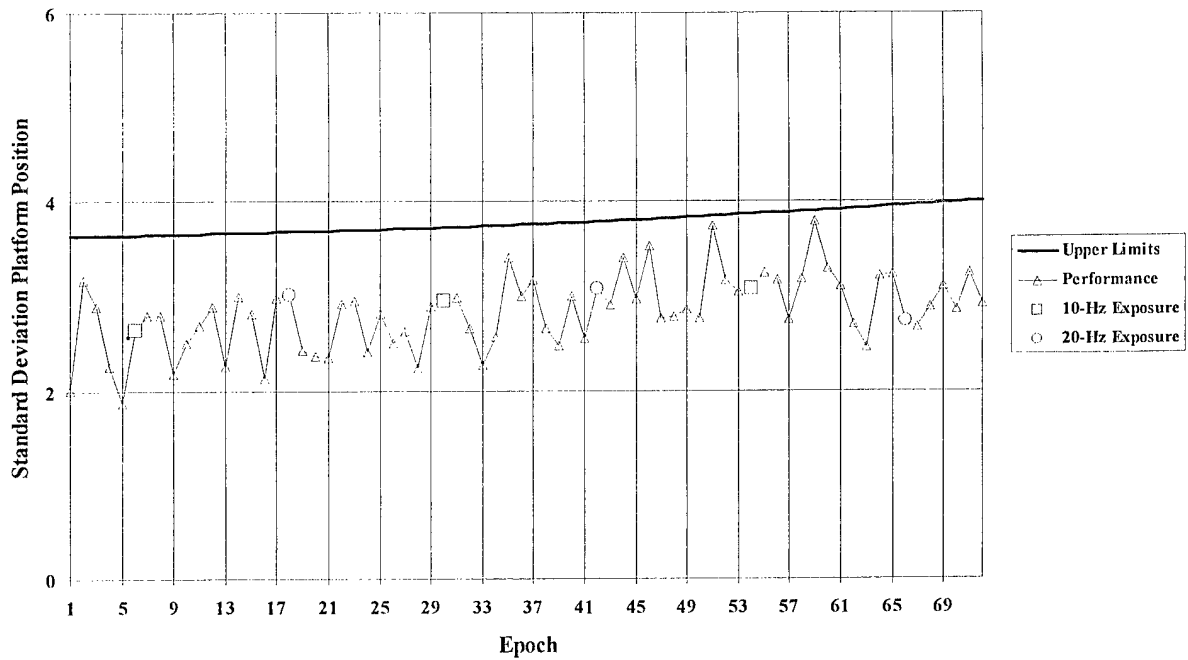

Figure 24. Performance of rhesus subject (510Z) on Primate Equilibrium Platform during second exposure session. (Square and circle symbols indicate the epochs during which the subject was exposed to 10- and 20-Hz signals, respectively.)

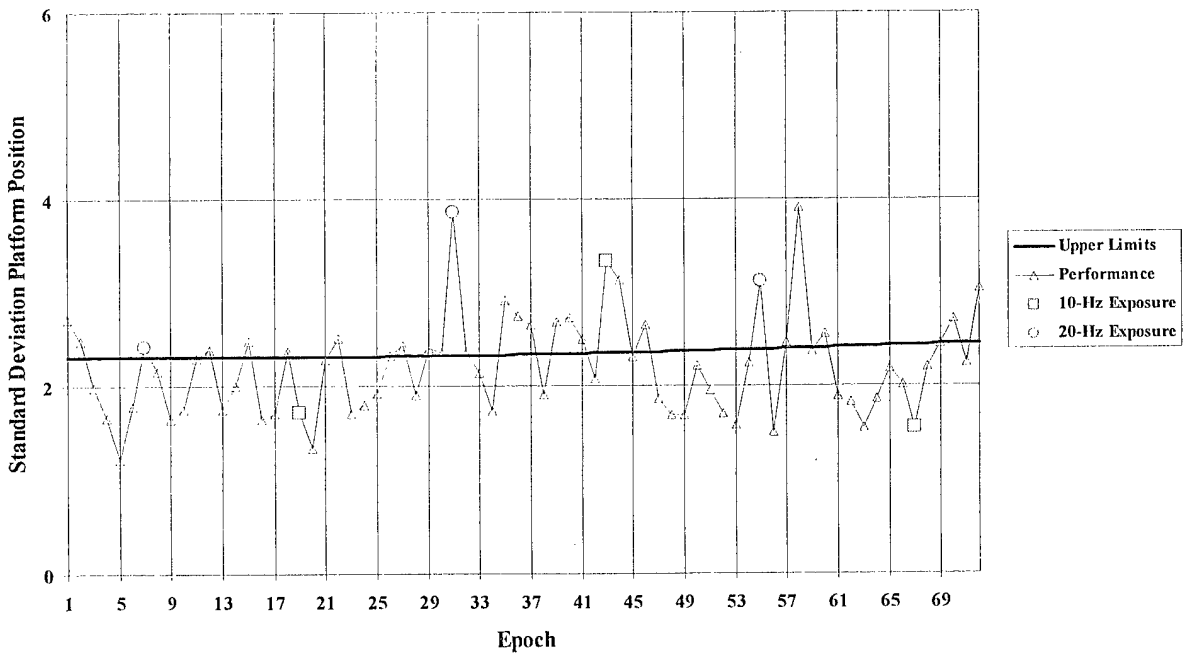

Figure 25. Performance of rhesus subject (952Z) on Primate Equilibrium Platform during second exposure session. (Square and circle symbols indicate the epochs during which the subject was exposed to 10- and 20-Hz signals, respectively.)

It appears that — unbeknownst to the experimenters — the feeding schedule for 952Z had been altered, and this subject was fed immediately prior to testing. Rhesus monkeys, when fed, will often hold much of their food in their cheek pouches. Both experimenters present during this session concurred in believing that it was the expanded cheek pouches — as opposed to any facet of the PEP task or the presence of the audio signals — that contributed to the relatively poor performance during this session. Specifically, it appeared to be the case that the neck collar used to restrain the subject in the PEP coupled with the presence of the expanded cheek pouches, caused the subject some minor discomfort, leading to more erratic performance.

In order to test this hypothesis, both subjects were tested for a third session (with the apparatus located 11 m from the speaker array, as was the case during Session 2).⁴ Neither of the subjects was fed until after the completion of the session. Figures 26 and 27 depict the PEP performance of both subjects (510Z and 952Z, respectively) during the third and final exposure session. There were no decrements in PEP performance for either subject during any of the 72 epochs; more specifically, there were no decrements during the 6 epochs during which a signal was present. The findings support the hypothesis that the poor performance exhibited by 952Z during Session 2 was a consequence of extraneous factors having nothing to do with the signals emitted by the speaker array. Moreover, they support the conclusion — based on the Session 1 data and the Session 2 data for Subject 510Z — that the output of the SRT speakers inside of a resonant reverberant chamber have no effect on the behavior of well-motivated subjects engaged in a continuous motor task.

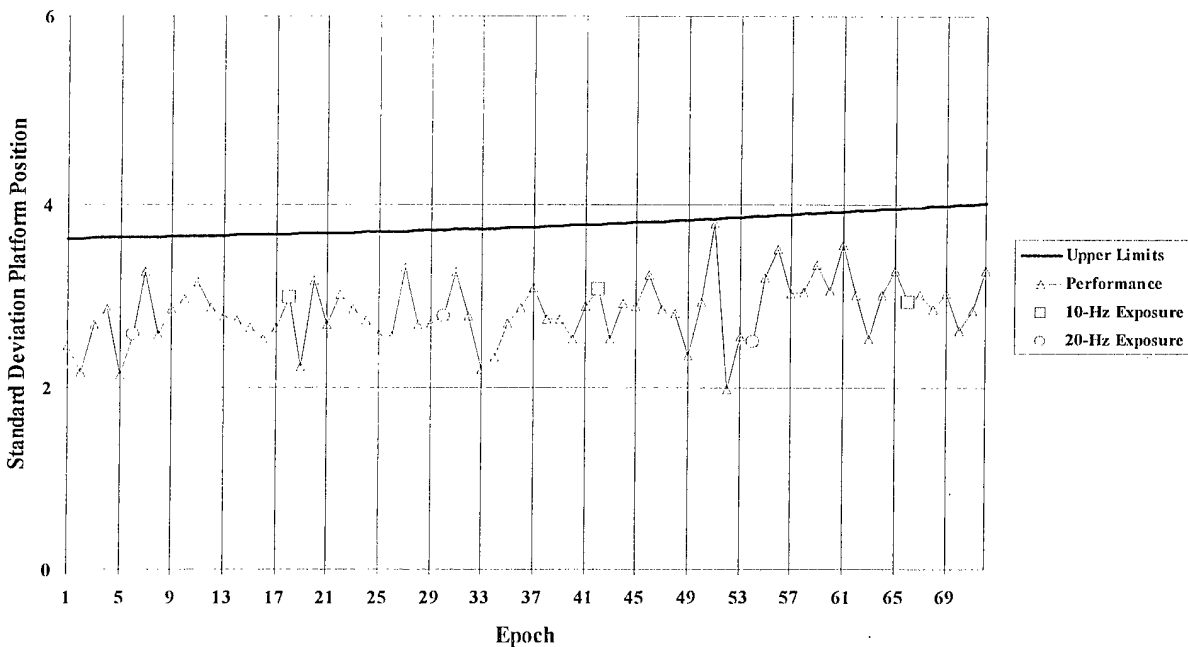

Figure 26. Performance of rhesus subject (510Z) on Primate Equilibrium Platform during third exposure session. (Square and circle symbols indicate the epochs during which the subject was exposed to 10- and 20-Hz signals, respectively.)

⁴ Subjects were originally scheduled to receive only two rather than three exposure sessions in the resonant chamber.

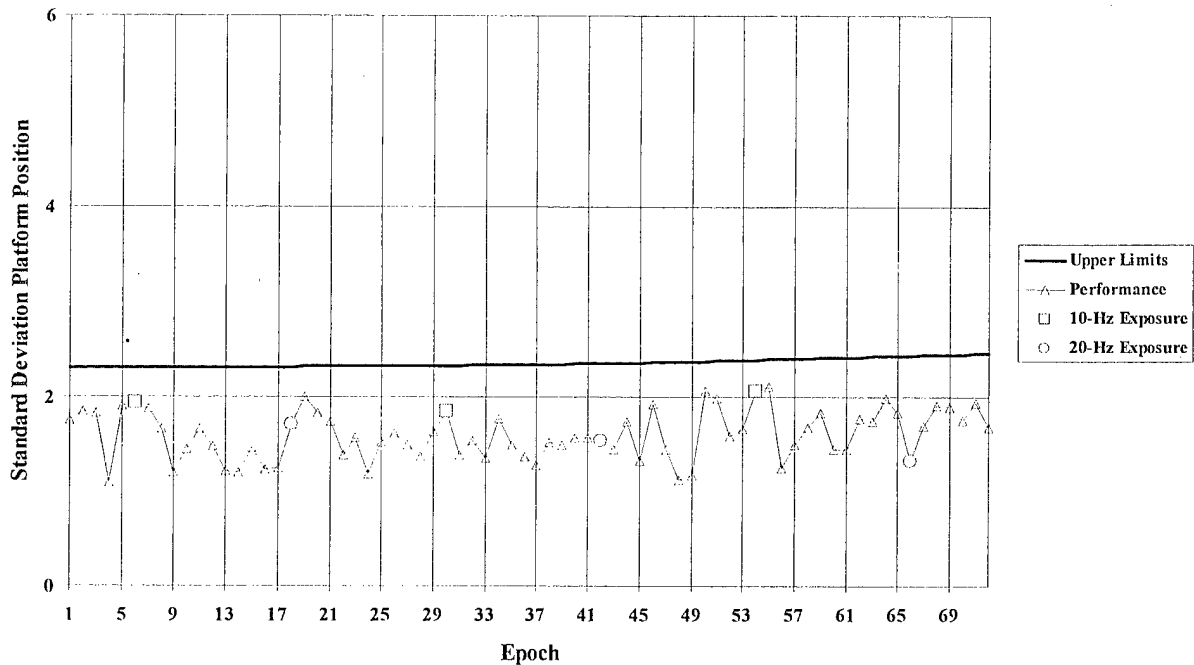

Figure 27. Performance of rhesus subject (952Z) on Primate Equilibrium Platform during third exposure session. (Square and circle symbols indicate the epochs during which the subject was exposed to 10- and 20-Hz signals, respectively.)

GENERAL DISCUSSION

Significance of the Results of the Present Experiments and Previous Acoustic Experiments Performed by the Directed Energy Division

Although Edge and Mayes (1965) had previously designed a low-frequency noise facility with a moveable tuning wall, the present experiments were the first to be performed in an enclosure simulating the common rectangular shape of a room. In contrast, previous tests by Edge and Mayes (1966) and Mueller and Mayes (1967) were performed in a cylindrical test chamber (Edge and Mayes, 1965), which was essentially a refurbished portion of a space launch vehicle.

On the basis of the previous work by von Békésy (1936) and von Gierke and Parker (1976), who reported pain threshold in humans at a level of 140 dB at frequencies of 15 and 20 Hz, respectively, some of the exposures in the current experiments (including those with a sound pressure of 145 dB at 20 Hz) might have been expected to cause noticeable effects. Such effects, however, were not seen in either pigs or monkeys exposed to this high sound level. The creation of standing waves in the chamber did not appear to be significant enough to bring about behavioral changes in the animals that were exposed. This lack of effects is consistent with some of the earlier work by Mueller and Mayes (1967), in which squirrel monkeys exposed to 2 Hz at 140 dB showed no evidence of discomfort. Some of those exposures lasted for 6 hours.

Since basic physiological mechanisms of the animal models in the present experiments are similar to those in humans, the effects may be extrapolated to potential effects in humans. Thus, one may also have expected a lack of effects in humans. In fact, in studies by other investigators, humans exposed to 10-15 Hz at 130-135 dB for 30 minutes exhibited no changes in hearing level, vestibular function, or autonomic nervous functions (Taenaka, 1989). Borredon (1972) noted that 7.5 Hz infrasound at 130 dB for 50 minutes had a negligible effect on simple reaction time in men. Borredon and Nathalie (1973) exposed men to pure tones of infrasound (again at 130 dB), and found that some subjects exhibited decreased performance on some tasks, while other subjects actually exhibited improvements in performance. Kyriakides and Leventhall (1977) reported no statistically significant effects on task performance in subjects exposed to a band of infrasound extending from 2 to 15 Hz at 115 dB. The authors speculated that performance on tasks of longer durations could potentially be affected by infrasound; there has, however, been no further evidence to support this claim.

Effects of Different Materials on Surfaces of Rooms

In the present experiments, the concrete surfaces of the acoustic chamber (simulated "room") were unpainted. As sound frequency decreases from 4000 Hz down to 125 Hz, the sound absorption coefficients of "unpainted, rough finish" floor and ceiling surfaces become identical to those of "sealed or painted" surfaces (Systems Development Group, Inc., 2000). Thus, it is doubtful that painting of the surfaces involved in the present experiments would have significantly affected the results.

A number of factors could decrease acoustic energy coupling. For example, the presence of ducts in walls (Cummings and Kirby, 1999), rigid incomplete partitions (Petyt et al., 1977), single, double, and triple leaf partitions with staggered stud configurations (Plumb, 1995), and the condition of wall edges can greatly affect the transmission of low-frequency sound (Gibbs and Maluski, 1998). The quality of low-frequency sound in a room can also be altered by different types of sound-absorbing material (Yuichi, 1998), including: (a) plastic, synthetic rubber, acrylic rubber, polyvinyl chloride, glass fiber, and laminated material (Souma, 1988); (b) polymer blends, epoxy resins, polybutadiene, composite materials, and honeycomb structures (Serizawa et al., 1989); (c) polyethylene (Serizawa et al., 1988); and (d) polybutadiene, aliphatic alcohols, inorganic acid esters, organocyno compounds, and polyphenol (Tanaka et al., 1988). Since there were no effects shown in our bioeffects experiments, testing of such materials was not deemed necessary, as they would only serve to decrease the sound intensity. The potential effectiveness of infrasound in a hostage rescue situation is made even more tenuous by this fact.

Is the Potential of Infrasound Overrated?

Infrasound and other acoustic generators represent a completely new mode of weapons based on novel physical principles (compared to existing non-lethal weapons). This novel approach may be part of the attraction for some. With this in mind, a lack of understanding of the physical principles could lead to the premature development of "prototype weapons" before testing or even reasonable consideration of such principles has occurred. Anecdotal reports of extraordinary "acoustic or infrasound weapon" effects can make meaningful assessment and

review of this area very difficult. Some of our previous bioeffects research studies (Sherry et al., 2000) have shown that the weapons capabilities of audible sound generators have been grossly overstated.

It has often been suggested that infrasound generators could be powerful enough to trigger nausea or diarrhea (e.g., Horgan, 1994). It has also been noted that acoustic systems using infrasound could, in theory, cause a loss of muscle control or unconsciousness (Alexander and Klare, 1995). Thomas (1999) reported that an article in a Chinese military medicine journal (Anonymous, 1997) claimed that an infrasound weapon had already been developed and tested, and that the device was adjustable to cause controllable amounts of disorientation, nausea, vomiting, and incontinence. The details of this work, however, have not been reported in the English literature. In a review of the technology, the Swedish Defence Material Administration concluded that the possible danger due to infrasound "has been much over rated" (Defence Material Administration, 1985).

Bunker (2000) noted that the alleged effects of infrasound for use as a non-lethal weapon have been questioned due to contradictory evidence presented in previous reports. For example, when discussing the practical limitations of technology, Altmann (1999) has suggested that, due to basic physical principles, the development of a useful weapon using high-intensity acoustic energy is unlikely. Harris and Johnson (1978) exposed humans to 7 Hz at 142 dB for 15 minutes and found no decrements in performance and no subjective reports of dizziness or disorientation. The authors concluded that potential adverse effects of infrasound had been exaggerated in previous reports. Johnson (1975) stated: "...infrasound is an overrated phenomenon as far as some authors would have you believe. Animals and people do not 'fall apart' due to infrasound. The 'infrasonic death ray' should at best be confined to the comics."

The Likelihood of Future Success in the Use of Infrasound for Hostage Rescue

The most recent prototype acoustic test chamber developed to support experiments at infrasonic frequencies (Boesch et al., 2000) can produce sound pressure levels in excess of 140 dB. The test volume, however, is only 5 cubic meters. Although some of our earlier experiments used technology that enabled achievement of sound pressures as high as 165 dB (at 0.5 Hz), those studies were performed using the Infrasound Test System, which is a steel chamber measuring 89 cm in diameter and 63 cm in depth. The use of infrasound in such small volumes would not appear to be relevant to hostage rescue scenarios.

In previous experiments performed by AFRL using frequencies slightly greater than infrasound, conscious pigs exposed to 40 Hz at 165 dB exhibited no bio-behavioral effects that would be of use (Sherry et al., 2001a). These studies were performed in an enclosure measuring 168 cm in length, 94 cm in width, and 131 cm in height. The animals were not able to perform experimental behavioral tasks due to the large changes in air pressure that were necessary to obtain 165 dB (with obviously high volumes of air flowing directly across the animals). However, no gross physiological effects were evident after 5 minutes of exposure, and the animals resumed normal eating and drinking behavior immediately after exiting the enclosure.

Even if an effect could be obtained in a volume large enough to be of use in a hostage rescue scenario, a notable limitation of infrasound acoustics for use as a non-lethal weapon is the

requirement for large amplifiers and large volume speakers (Siniscalchi, 1998). This may severely limit the mobility of any proposed weapon.

CONCLUSIONS

Given our present and previous results, and the earlier results of other investigators, it seems unlikely that high-intensity acoustic energy in the infrasonic or low-frequency range will provide a device suitable to be used to facilitate hostage rescue. Specifically, the present results indicate that ongoing goal-directed behavior in motivated subjects is not altered by exposure to infrasound for a relatively brief period of time. The difficulty of obtaining sound pressure levels high enough to be effective in a large volume would not suggest the need for further extensive experimentation in this area of research.

ACKNOWLEDGEMENTS

This work was supported by National Institute of Justice (NIJ) Inter-Agency Agreement No. 97-DT-R-069. Dr. Peter Nacci, Deputy Director, Joint Program Steering Group, was the project manager for NIJ. The authors wish to acknowledge Clarence Theis for his technical support, and Charles Kuhnel for his assistance in determining the electrical characteristics of the sound equipment. The moveable door for the acoustic chamber was developed by Henry Whitmore (Whitmore Enterprises, San Antonio, TX). Champbell Systems (San Antonio, TX) was general contractor for construction of the resonant chamber.

REFERENCES

- Alexander LR, Klare JL. (1995) Nonlethal weapons: New tools for peace. *Issues in Science and Technology* 12(2): 67.
- Altmann J. (1999) *Acoustic Weapons — A prospective assessment: Sources, propagation and effects of strong sound*. Ithaca, NY: Cornell University Peace Studies Program. (Available at URL: <http://www.einaudi.cornell.edu/PeaceProgram/acousticweapons.pdf>; accessed 28 Nov 2001).
- Anonymous (1997). *New concept weapons and its medical-related problems [Chinese]*. Beijing *Renmin Junyi* (9) (Sept): 507-508.
- Anonymous. (1998) LTL definition could affect development. *Tech Connection* (Newsletter of the National Law Enforcement and Corrections Technology Center – Rocky Mountain Region Center) 3(3): 2,4; Jul-Sept 1998. Available at URL: <http://www.nlectc.org/pdffiles/TCJulSept98.pdf> (accessed 28 Nov 2001).
- Barry J, Everett M, Peck A. (1994) *Nonlethal military means: New leverage for a new era*. National Security Program Policy Analysis Paper 94-01. Harvard University: John F. Kennedy School of Government.
- Blick DW, Murphy MR, Brown GC, Hartgraves SL. (1994) Primate performance decrements following acute soman exposure: Failure of chemical countermeasures. *Pharmacology, Biochemistry and Behavior* 49: 503-510.
- Boesch HE Jr, Benwell BT, Reiff CG. (2000) Design and test of a prototype acoustic high-intensity infrasonic test chamber. Army Research Laboratory Technical Report ARL-TR-2137, April 2000. Available at URL: http://stinet.dtic.mil/cgi-bin/fulcrum_main.pl?database=ft_u2&searchid=10069780917712&keyfieldvalue=ADA377759 (accessed 28 Nov 2001).
- Borredon P. (1972) *Reaction physiologiques de sujets humains exposes a des infrasons*. Report No. 3710. Centre de Recherches de Medecine Aeronautique.
- Borredon P, Nathie J. (1973) The psychological effects observed on a man exposed to an infrasonic level of 130 dB. Report of the International Colloquium on Infrasound. Paris, France: Sept 1973; pp. 61-84.
- Bunker RJ. (2000) Non-lethal weapons conferences. *Military Review* 80(2) (Mar-Apr): 103-104.
- Cole JN, Mohr GC, Guild E, von Gierke HE. (1966) *The effects of low frequency noise on man as related to the Apollo space program*. Aeromedical Research Laboratory Technical Report No. AMRL-TR-66-119; Wright-Patterson Air Force Base, Ohio.

Coppernoll, M.A. (1999) The nonlethal weapons debate. *Naval War College Review* 52(2, Spring): 112-131. Available at URL: <http://www.nwc.navy.mil/press/Review/1999/spring/art5-sp9.htm> (accessed 28 Nov 2001).

Council on Foreign Relations (1999) *Nonlethal technologies: Progress and prospects*. Independent Task Force Report. Available at URL: <http://www.cfr.org/public/pubs/Non-ViolentTaskForce.html> (accessed 28 Nov 2001).

Cummings A, Kirby R. (1999) Low-frequency sound transmission in ducts with permeable walls. *Journal of Sound and Vibration* 226: 237-251.

Defence Material Administration. (1985) *Infrasound: A Summary of Interesting Articles*. Report Number FMV:ELEKTRO-A12:142/83. Stockholm, Sweden: Defence Material Administration, Radio Department; May 1985.

Edge PM Jr, Mayes WH. (1965) *Description and research capabilities of the Langley low-frequency noise facility*. Hampton, VA: NASA Langley Research Center; June 1965. (Available from National Technical Information Service; Report No. N6622257)

Edge PM Jr, Mayes WH. (1966) *Description of Langley low-frequency noise facility and study of human response to noise frequencies below 50 cps*. NASA Technical Note NASA-TN-D-3204.

Farrer D, Yochmowitz M, Mattsson J, Lof N, Bennett C. (1982) Effects of benactyzine on an equilibrium and multiple response task in rhesus monkeys. *Pharmacology, Biochemistry and Behavior* 16: 605-609.

Fischetti M. (1995) Less-than-lethal weapons. *Technology Review* 98 (Jan): 14-15.

Gibbs BM, Maluski S. (1998) Sound level difference between dwellings at low frequencies. Distribution of low frequency sound levels in rooms. *Proceedings of INTER-NOISE 98, The 1998 International Congress on Noise Control Engineering*. Christchurch, New Zealand, 16-18 Nov 1998.

Hannigan TJ, Raff L, and Paschall R. (1996) *Mission applications of non-lethal weapons*. Report for Office of the Assistant Secretary of Defense for Special Operations and Low Intensity Conflict (Policy Planning). Appendix C. Aug 1996.

Harris CS, Johnson DL. (1978) Effects of infrasound on cognitive performance. *Aviation, Space and Environmental Medicine* 49: 582-586.

Harris CS, Sommer HC, Johnson DL. (1976) Review of the effects of infrasound on man. *Aviation, Space and Environmental Medicine* 47: 430-434.

Horgan J. (1994) Bang! You're alive. *Scientific American* 270(4) (Apr): 22,24.

- Johnson DL. (1973) Effects of infrasound on respiration. Preprints of the Annual Meeting of the Aerospace Medical Association; Las Vegas, Nevada; 7-10 May; pp. 37-38.
- Johnson DL. (1975) Auditory and physiological effects of infrasound. Aeromedical Research Laboratory Technical Report No. ARML-TR-75-33; Wright-Patterson Air Force Base, Ohio; Sept 1975.
- Kyriakides K, Leventhall HG. (1977) Some effects of infrasound on task performance. *Journal of Sound and Vibration* 50: 369-388.
- Lieberman G, Miller R. (1963) Simultaneous tolerance intervals in regression. *Biometrika* 50: 155-168.
- Lim DL, Dunn DE, Johnson D L, Moore TJ. (1982) Trauma of the ear from infrasound. *Acta Oto-Laryngologica* 94: 213-231.
- Mohr GC, Cole JN, Guild E, von Gierke HE. (1965) Effects of low frequency and infrasonic noise on man. *Aerospace Medicine* 36: 817-824.
- Mueller AW, Mayes WH. (1967) Acoustic exposure tests of squirrel monkeys in the Langley low frequency noise facility. NASA Langley Working Paper No. 412; 11 May 1967.
- Nixon CW. (1974) Human auditory response to intense infrasound. USAF Aeromedical Research Laboratory Technical Report AMRL-TR-74-2; Wright-Patterson Air Force Base, Ohio.
- Nixon CW, Hille HK, Kettler LK. (1967) Attenuation characteristics of earmuffs at low audio and infrasonic frequencies. Aeromedical Research Laboratory Technical Report No. AMRL-TR-67-27; Wright-Patterson Air Force Base, Ohio.
- Olesen SK, Moller H. (1998) Distribution of low frequency sound levels in rooms. Proceedings of INTER-NOISE 98, The 1998 International Congress on Noise Control Engineering. Christchurch, New Zealand, 16-18 Nov 1998.
- Petyt M, Koopmann GH, Pinnington RJ. (1977) The acoustic modes of a rectangular cavity containing a rigid, incomplete partition. *Journal of Sound and Vibration* 53: 71-82.
- Plumb GD. (1995) Lightweight partitions having improved low frequency sound insulations. Report Number BBC-RD-1995/6. Tadworth, England: British Broadcasting Corporation.
- Serizawa M, Takahashi T, Souma I, Ogawa H, Tanaka Y, Yamaguchi M. (1989) Research on composite materials preventing low-frequency sound [Japanese]. *Environmental Research in Japan* 2: 70.1--70.14.
- Serizawa M, Tanaka Y, Souma I. (1988) Measurements of sound isolation capabilities of polymer materials on low frequency sound [Japanese]. Proceedings of the Meeting of the Institute of Noise Control Engineering of Japan: 197-200.

Sherry C, Ziriak J, Walters T, Rodney G. (1994) Operant conditioning of the unrestrained goat (*Capra hircus*). *Small Ruminant Research* 13: 9-13.

Sherry CF, Cook MC, Brown GC, Jauchem JR, Merritt JH, Murphy MR. (2000) An assessment of four acoustic devices on animal behavior. US Air Force Research Laboratory Technical Report AFRL-HE-BR-TR-2000-0153, Oct 2000. Available at URL: http://stinet.dtic.mil/cgi-bin/fulcrum_main.pl?database=ft_u2&searchid=100532467613850&keyfieldvalue=ADA385802 (accessed 28 Nov 2001).

Sherry CF, Jauchem JR, Brown GC, Cook MC. (2001a) Biological and behavioral effects of exposure to acoustic energy in the infrasound or low-sonic frequency range. US Air Force Research Laboratory Technical Report AFRL-HE-BR-TR-2001- , in preparation.

Sherry CF, Cook MC, Jauchem JR, Brown GC. (2001b) The bio-behavioral effects of infrasound on the performance of a non-human primate on a continuous compensatory tracking task. *Aviation, Space and Environmental Medicine*, submitted.

Siniscalchi J. (1998) Non-lethal technologies: Implications for military strategy. Occasional Paper No. 3. Maxwell Air Force Base, Alabama: Center for Strategy and Technology, Air War College, Air University; March 1998. Available at URL: http://research.maxwell.af.mil/papers/special_collection/csat/csat3.pdf (accessed 28 Nov 2001).

Slarve RM, Johnson DL. (1975) Human whole-body exposure to infrasound. *Aviation, Space and Environmental Medicine* 46: 428-431.

Souma I. (1988) Low frequency sound pollution and damping materials [Japanese]. *Journal of the Society of Rubber Industry* 61(1): 11-18.

Stambaugh H, Tillery C, Schaenman P. (1999) Inventory of state and local law enforcement technology needs to combat terrorism. National Institute of Justice Research in Brief 173384, Jan 1999. Available at URL: <http://www.ncjrs.org/pdffiles1/173384.pdf> (accessed 28 Nov 2001).

Systems Development Group, Inc. (2000) Acoustic calculator. [World Wide Web Page] URL: <http://www.sysdevgrp.com/cgi-bin/calculator.p15> (accessed 30 Aug 2001; to be available in the future at URL: <http://www.acousticsfirst.com/>).

Taenaka K. (1989) A study on the effect of infrasound [Japanese]. *Nippon Jibiinkoka Gakkai Kaiho* 92: 1399-1415.

Tanaka Y, Serizawa M, Ogawa H. (1988) Low frequency sound isolation capability of epoxy-polybutadiene composites [Japanese]. *Chemistry Express* 3(9): 571-574.

Thomas TL. (1999) Human network attacks. *Military Review* 79(5) (Sept-Oct): 23-33.

US House of Representatives. (1994) 103d Congress Report of the 2nd Session. 103-701 National Defense Authorization Act for Fiscal Year 1995. Section 1112. Support for technologies with applicability for law enforcement and military operations other than war. 12 Aug 1994.

von Békésy G. (1936) Über die hörschwelle und fühlgrenze langsamer sinusformiger luftdruckschwankungen [German]. *Annalen der Physik* 26: 554-566.

von Gierke HE, Parker DE. (1976) Infrasound. In: Keidel WD, Neff WD (eds). *Handbook of Sensory Physiology. Vol. V: Auditory System. Part 3: Clinical and Special Topics.* Berlin: Springer-Verlag; pp. 355-624.

Wever EC, Bray CW. (1936) The perception of low tones and the resonance volley theory. *Journal of Psychology* 3: 101.

Yuichi A. (1998) Change in low-frequency characteristics of enclosure by sound absorbing material [Japanese]. *Audio Technology* 85(9): 70-75.