



# Experimental Comparison of Face-Milled and Face-Hobbed Spiral Bevel Gears

Robert F. Handschuh  
U.S. Army Research Laboratory, Glenn Research Center, Cleveland, Ohio

Michael Nanlawala  
Illinois Institute of Technology, Chicago, Illinois

John M. Hawkins  
Rolls-Royce Corporation, Indianapolis, Indiana

Danny Mahan  
U.S. Army AMCOM, Redstone Arsenal, Huntsville, Alabama

**DISTRIBUTION STATEMENT A**  
Approved for Public Release  
Distribution Unlimited

20020204 168

## The NASA STI Program Office . . . in Profile

Since its founding, NASA has been dedicated to the advancement of aeronautics and space science. The NASA Scientific and Technical Information (STI) Program Office plays a key part in helping NASA maintain this important role.

The NASA STI Program Office is operated by Langley Research Center, the Lead Center for NASA's scientific and technical information. The NASA STI Program Office provides access to the NASA STI Database, the largest collection of aeronautical and space science STI in the world. The Program Office is also NASA's institutional mechanism for disseminating the results of its research and development activities. These results are published by NASA in the NASA STI Report Series, which includes the following report types:

- **TECHNICAL PUBLICATION.** Reports of completed research or a major significant phase of research that present the results of NASA programs and include extensive data or theoretical analysis. Includes compilations of significant scientific and technical data and information deemed to be of continuing reference value. NASA's counterpart of peer-reviewed formal professional papers but has less stringent limitations on manuscript length and extent of graphic presentations.
- **TECHNICAL MEMORANDUM.** Scientific and technical findings that are preliminary or of specialized interest, e.g., quick release reports, working papers, and bibliographies that contain minimal annotation. Does not contain extensive analysis.
- **CONTRACTOR REPORT.** Scientific and technical findings by NASA-sponsored contractors and grantees.

- **CONFERENCE PUBLICATION.** Collected papers from scientific and technical conferences, symposia, seminars, or other meetings sponsored or cosponsored by NASA.
- **SPECIAL PUBLICATION.** Scientific, technical, or historical information from NASA programs, projects, and missions, often concerned with subjects having substantial public interest.
- **TECHNICAL TRANSLATION.** English-language translations of foreign scientific and technical material pertinent to NASA's mission.

Specialized services that complement the STI Program Office's diverse offerings include creating custom thesauri, building customized data bases, organizing and publishing research results . . . even providing videos.

For more information about the NASA STI Program Office, see the following:

- Access the NASA STI Program Home Page at <http://www.sti.nasa.gov>
- E-mail your question via the Internet to [help@sti.nasa.gov](mailto:help@sti.nasa.gov)
- Fax your question to the NASA Access Help Desk at 301-621-0134
- Telephone the NASA Access Help Desk at 301-621-0390
- Write to:  
NASA Access Help Desk  
NASA Center for Aerospace Information  
7121 Standard Drive  
Hanover, MD 21076



# Experimental Comparison of Face-Milled and Face-Hobbed Spiral Bevel Gears

Robert F. Handschuh  
U.S. Army Research Laboratory, Glenn Research Center, Cleveland, Ohio

Michael Nanlawala  
Illinois Institute of Technology, Chicago, Illinois

John M. Hawkins  
Rolls-Royce Corporation, Indianapolis, Indiana

Danny Mahan  
U.S. Army AMCOM, Redstone Arsenal, Huntsville, Alabama

Prepared for the  
International Conference on Motion and Power Transmission  
sponsored by the Japan Society of Mechanical Engineers  
Fukuoka, Japan, November 15-17, 2001

National Aeronautics and  
Space Administration

Glenn Research Center

Available from

NASA Center for Aerospace Information  
7121 Standard Drive  
Hanover, MD 21076

National Technical Information Service  
5285 Port Royal Road  
Springfield, VA 22100

Available electronically at <http://gltrs.grc.nasa.gov/GLTRS>

# EXPERIMENTAL COMPARISON OF FACE-MILLED AND FACE-HOBBED SPIRAL BEVEL GEARS

Robert F. Handschuh  
U.S. Army Research Laboratory  
NASA Glenn Research Center  
Cleveland, Ohio

Michael Nanlawala  
Illinois Institute of Technology, IITRI  
Chicago, Illinois

J. Matthew Hawkins  
Rolls-Royce Corporation  
Indianapolis, Indiana

Danny Mahan  
U.S. Army AMCOM, Redstone Arsenal  
Huntsville, Alabama

## ABSTRACT

An experimental comparison of face-milled and face-hobbed spiral bevel gears was accomplished. The two differently manufactured spiral bevel gear types were tested in a closed-loop facility at NASA Glenn Research Center. Strain, vibration, and noise testing were completed at various levels of rotational speed and load. Tests were conducted from static (slow-roll) to 12600 rpm and up to 269 N•m (2380 in•lb) pinion speed and load conditions. The tests indicated that the maximum stress recorded at the root locations had nearly the same values, however the stress distribution was different from the toe to the heel. Also, the alternating stress measured was higher for the face-milled pinion than that attained for the face-hobbed pinion (larger minimum stress). The noise and vibration results indicated that the levels measured for the face-hobbed components were less than those attained for the face-milled gears tested.

## INTRODUCTION

Spiral bevel gears are important components on all current rotorcraft drive systems. These components are required to operate at high speed and load and for an extremely large number of cycles in these applications. An example of spiral bevel gears use in a rotorcraft drive system is shown in Fig. 1 [1]. In this application spiral bevel gears are not only used to turn the corner from the horizontal engines to the vertical rotor but also as a means of combining the two engines to power the main and tail rotor shafts.

Gears that are manufactured for this purpose are made to the highest quality economically attainable (AGMA quality 12 and higher, usually [13–14]) and using the best current materials. Utilizing these specialty manufacturing machine tools and computer numerical controlled coordinate measurement has

enabled rotorcraft drive system manufacturers to produce “master quality” gears in their production facilities. Since these gears are not manufactured in the quantities as would be seen in the automobile industry, production quantities of < 50 sets of gears are commonplace [2–4]. There is no economy in high production numbers realized for these aerospace components. Therefore methods of manufacture that could reduce costs without compromising the requirements for a given application are highly desirable.

Also, the manufacture of precision-ground spiral bevel gears requires many complicated steps. Failure to successfully complete any of these steps, during the manufacturing process, results in the part being scrapped. Therefore if a manufacturing

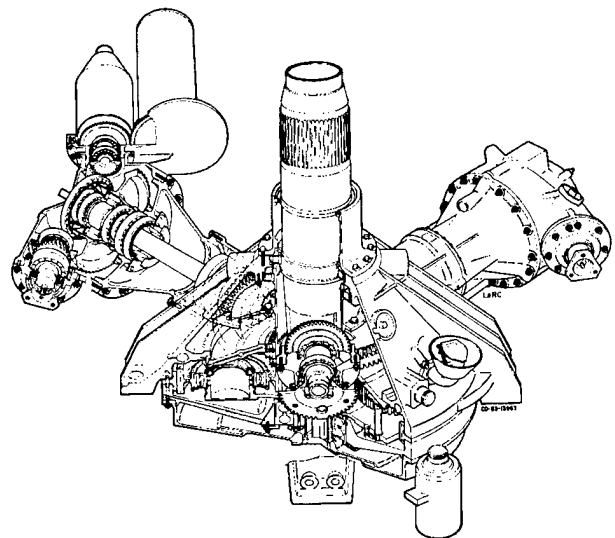

Figure 1.—UH-60 helicopter main rotor transmission cross section.

process could be found that could reduce the number of manufacturing steps, this would reduce costs and lower the chances that a particular manufacturing step will cause the gear to be scrapped.

The project to be described in this report compares the operational behavior of face-milled, the current manufacturing process for spiral bevel gears used in aerospace applications, to face-hobbed spiral bevel gears that have potential manufacturing cost savings. Testing results on spiral bevel gears in general have limited availability in the open literature, as the majority of information found has been done on parallel axis gears. There have been some studies that have looked at measurements, similar to the data taken in this report, within high-speed helicopter gearboxes or in specially fabricated test rigs for intersecting axis gears [1, 5–10]. However these results have only been on face-milled spiral bevel gears.

Test hardware was manufactured to fit within the NASA Glenn Research Center Spiral Bevel Gear Test Facility and gears were manufactured to aerospace quality. Tests were conducted for stress, vibration and noise. A comparison of the results attained will be presented.

## GEAR MANUFACTURE

Spiral bevel gears were manufactured using two different manufacturing methods. Face-milled and face-hobbed gears were manufactured to fit within the NASA Glenn Research Center Spiral Bevel Gear Test Facility. The basic design data for these gears are shown in Table 1. Gears were manufactured to aerospace precision quality.

The difference between the two different manufacturing methods is shown in Fig. 2 [11,12]. During the tooth generation process, in the face-milling technique, the grinding wheel interacts with one tooth space and is then indexed to the next location (cutting or grinding). The process continues until all tooth spaces are finish cut to the required depth. In the face-hobbing technique individual cutting blades interact with different tooth spaces. Face-hobbing is a continuously indexing tooth generation process, where all the teeth are cut a little at a time, until all the teeth are finished to the final desired depth. Test hardware that was face-milled was manufactured using grinding as the final machining process to the gears. For the face-hobbed gears the final operation is the hard-cutting process. Both manufacturing techniques gave similar surface texture and roughness. The pinions manufactured from the two different methods are shown in Fig. 3.

## TEST FACILITY/TEST SET-UP/TEST PROCEDURE

The test facilities that were used to conduct the experimental studies are located at NASA Glenn. The test facility is a closed-loop torque regenerative facility that tests two sets of spiral bevel gears at the same time. A sketch of the facility is shown in Fig. 4. The facility can change load and speed when desired with maximum conditions at the pinion being

Table 1 Basic spiral bevel gear design data

Number of teeth pinion/gear	12/36
Diametral pitch (1/in.)	5.141
Mean spiral angle (deg)	35.0
Mean cone distance (in.)	3.191
Face width (in.)	1.0
Nominal pressure angle (deg)	22.5
Shaft angle (deg)	90.0

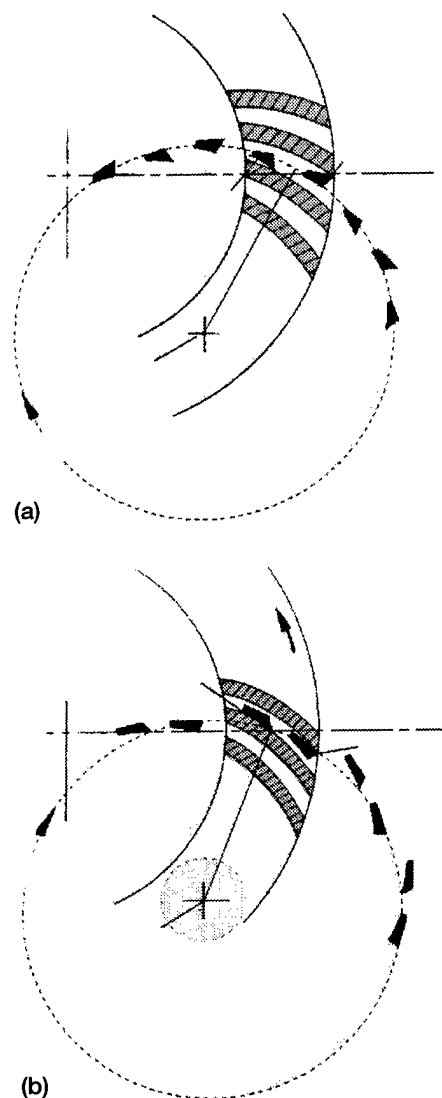

Figure 2.—Manufacturing methods.  
 (a) Face-milled (single indexing).  
 (b) Face-hobbed (continuous indexing)

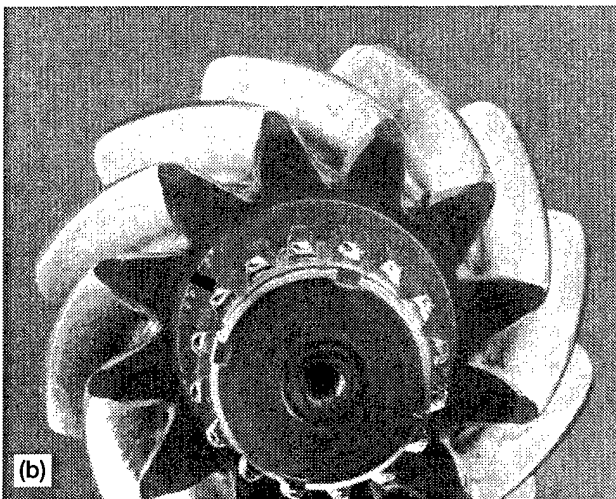
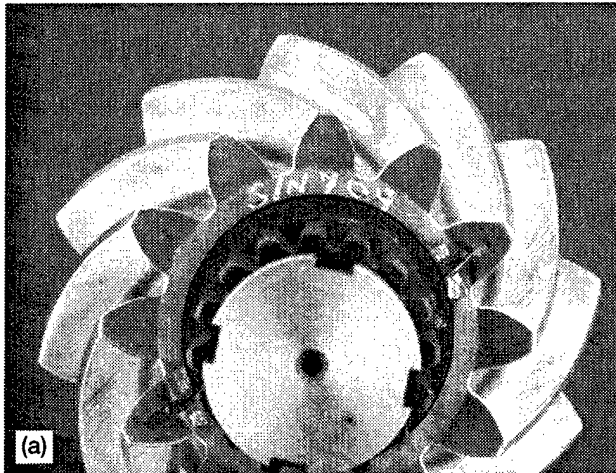

Figure 3.—Pinions. (a) Face-milled. (b) Face-hobbed.

20000 rpm and 559 kW (750 hp). The facility can be preloaded via a split coupling located on the slave side gear shaft. The rest of the load is applied using a floating helical gear that is forced into mesh via a thrust piston. The loop torque is measured at the test gear shaft side within the loop. Facility operational parameters are measured and recorded via a laboratory computer.

The test hardware was instrumented for these tests using strain gages. The gages were placed in the fillet and root areas to investigate the differences of the strain measured due to the face-milled and face-hobbed geometry differences. The strain gages used were only 0.38 mm (0.015 in.) active gage length to fit within the root and fillet regions without being immediately damaged by the meshing action of the teeth. An example of the strain gage arrangement is shown in Fig. 5. Strain gages were placed in position using a microscope. Fillet gages are the most troublesome with respect to placement. As will be seen later, many of the gages applied in this region were damaged in the build-up/pattern checking operation prior to operation.

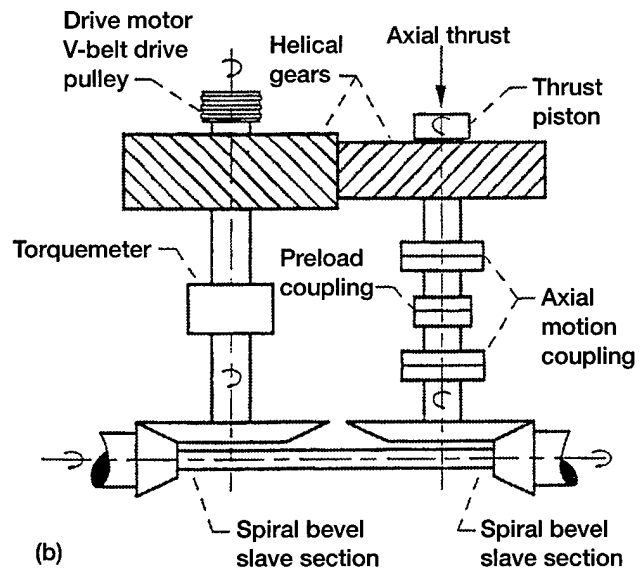
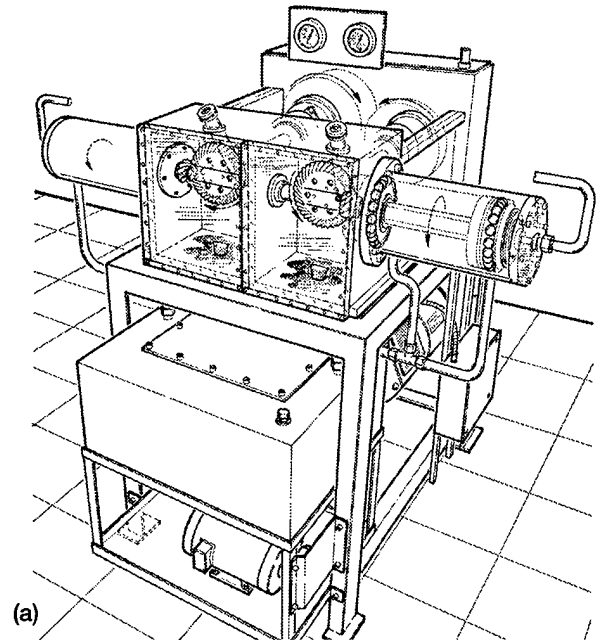

Figure 4.—NASA Glenn Research Center Spiral Bevel Gear Facility. (a) Sketch. (b) Facility cross section.

All root gages operated adequately over the test performed. High frequency accelerometers were also installed just above the pinion in the bearing support housing on both the test and slave sides. A hand-held sound level meter was used to make qualitative noise measurements. All the test procedures and measurements will be described in-depth later in this report.

Contact pattern development and backlash measurements are part of the normal setup procedure for spiral bevel gears. Contact patterns for the face-milled and face-hobbed gears at higher load (~282 N•m (2500 in.•lb) at the pinion shaft) are shown in Fig. 6. The one main item to note is that teeth on the

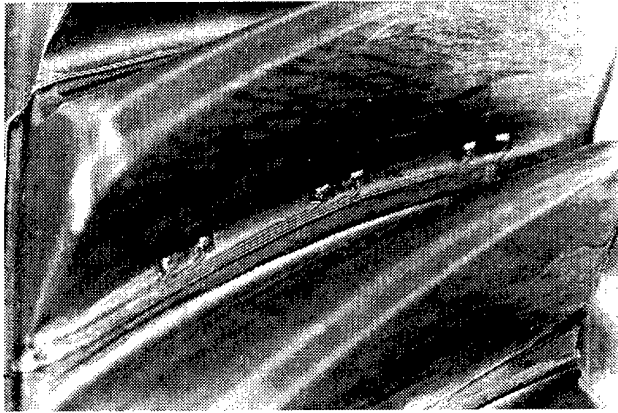

Figure 5.—Close-up of strain gage and associated wiring.

face-hobbed gears use a larger percentage of the available tooth profile than the face-milled teeth. Use of more of the tooth surface should intuitively have improved operational characteristics.

The procedure followed to conduct the tests was the following. First the facility was warmed up via the lube systems to the point where the lubrication inlet temperature for the test hardware was  $\sim 71^\circ\text{C}$  ( $160^\circ\text{F}$ ). The strain gage instrumentation was balanced at zero applied load. Next, calibration signals were applied to the tape recording system (used for strain gages and vibration data). Finally the necessary torque was applied prior to test operation through the split coupling. Once a set point of speed and torque were reached, data was recorded on tape for a predetermined period of time (typically 1 min).

#### DATA ACQUISITION

Data was taken for the test hardware using strain gages, high frequency accelerometers, and a sound level meter. Data from the strain gages and accelerometers was recorded on FM tape for post-test processing. The noise measurements were made using a hand-held sound level meter.

The tape-recorded data was downloaded to a personal computer using analog to digital boards contained within the personal computer. Dynamic data was time synchronous averaged using a once-per-revolution sensor attached to the gear shaft. For each revolution of the gear the pinion rotates 3 revolution (3:1 ratio). For the strain gage data that will be presented later, the data was typically averaged for 50 revolution of the gear shaft. All dynamic data was taken after set point conditions were reached (speed and load) for several minutes. Since strain gages have a finite life at high strain rates the facility was not operated for long periods while waiting for thermal equilibrium to be reached.

The strain gage wiring passed through a high-speed slip ring prior to being recorded on the FM tape recorder. No filtering of the raw data was made and all dynamic data was recorded at 30 in./sec tape speed.

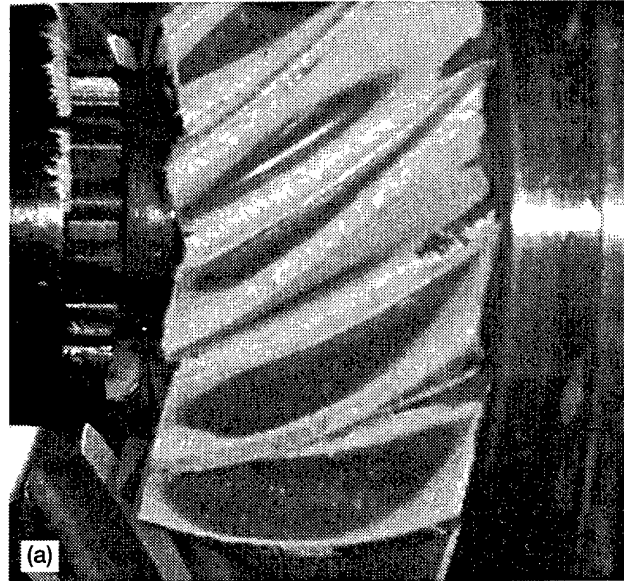

(a)



(b)

Figure 6.—High load contact patterns for gears.  
(a) Face-milled. (b) Face-hobbed.

The strain gage data was then downloaded to a personal computer. Calibration signals recorded on the tape recorder prior to operation were used to correct the tape recorder output. Once the data was corrected for tape recorder errors, the signals were then corrected for gage drift. The data was transformed from voltage to strain using shunt calibration information from each of the strain gage channels. Finally the strain was transformed to stress assuming a uniaxial stress field.

The vibration data that was taken used high-frequency accelerometers. The output from these sensors was recorded directly on the tape recorder without any filtering. The output was played back into a spectrum analyzer. The data was averaged (25 averages) over the spectrum from 0 to 12.8 kHz. Hanning windowing was used on the signals analyzed. The data reported later will show the fundamental and next harmonic of the meshing frequency.

The noise measurements were made using a hand-held sound level meter using the "A" weighted scale. Noise measurements were made at a distance of 15 cm (6 in.) from the lexan cover (a high strength clear plastic cover) on each side of the test facility. Peak sound pressure level was measured for a given set of conditions using an "A" weighted scale.

### EXPERIMENTAL RESULTS/COMPARISONS

In this part of the report the experimental results attained will be presented. The strain gage results will be described first, followed by the vibration and noise results. All results attained from the two different gear tooth surface geometries will then be compared for each of the measurement types made. For the face-milled results, the strain gage data was taken at a different time than the noise and vibration data. For the face-hobbed results, all data was taken at the same time for each of the conditions presented.

#### Strain Gage Results

While the aim of using strain gages is to measure the peak strain (calculated stress), gages used in the fillet region on gear teeth have a problem as mentioned earlier with placement and long operational life. However, gages placed in the root region will typically experience lower positive strain and be out of the way of the meshing gear member during installation/setup and operation.

An example of the strain gage output is shown in Fig. 7 for one revolution of the pinion. The data shows a general trend that all load and speed conditions produced. First of all the data shown for the face-milled test hardware was similar to tests conducted in the same test facility in an earlier study [6]. The mid face fillet gages produced the highest strain (stress) and the toe and heel gages measured lower values.

For the face-hobbed pinion the strain gage that was located at the mid face fillet location failed prior to any testing and only the two gages located at the heel locations produced data in the

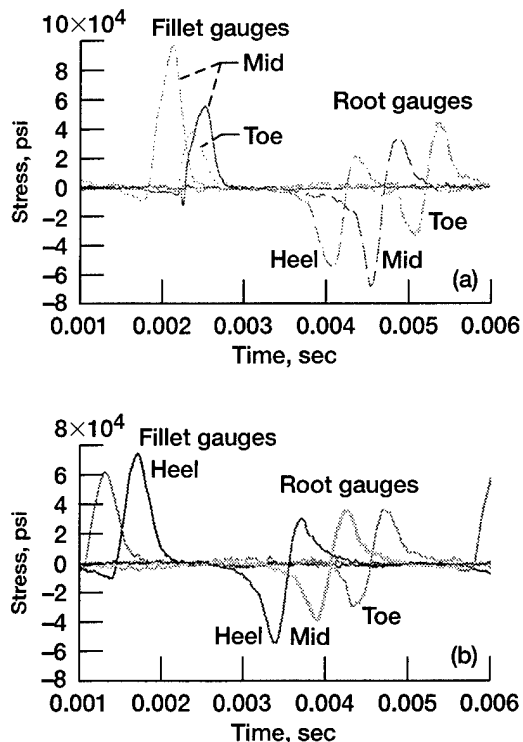

Figure 7.—Stress versus time for spiral bevel gears. (a) Face-milled (12 600 RPM 263.3 N•m (2330 in. •lb)). (b) Face-hobbed (12 600 RPM 268.9 N•m (2380 in. •lb)).

fillet region of the tooth. The level of strain (stress) was similar in value to results found from the face-milled test hardware. One thing to note from the results of Fig. 7 is that the root gage output was different for the two different gear types. The root gages on the face-milled pinion had the maximum alternating stress at the mid position root gage and the face-hobbed pinion had the maximum alternating stress at the heel position.

A complete summary of the strain gage data taken for the face-milled and face-hobbed pinions is shown in Tables 2 and 3 respectively. The values found from the time synchronously averaged data are in the tables. The time synchronous averaging produced results approximately every degree of pinion rotation. Four different conditions are presented for both gear types in these two tables. As can be seen, the fillet locations produced the highest tensile stress and the root locations produced the highest compressive stress. A comparison of the

Table 2 Strain gage location and results from experiments for face-milled spiral bevel gears

RPM/load, in. •lb, pinion	Fillet gage stress, ksi Maximum/Minimum			Root gage stress, ksi Maximum/Minimum		
	Mid	Toe	Mid	Toe	Mid	Heel
7200/1487	47.4/-4.8	21.1/-2.1	63.9/-7.9	24.8/-24.1	26.0/-41.6	12.1/-36.4
10800/1607	51.8/-4.0	26.9/-2.9	68.4/-6.2	25.8/-22.2	26.6/-46.0	17.4/-36.7
10800/2367	66.6/-4.4	39.9/-2.9	94.8/-10.6	37.1/-30.7	37.3/-66.8	22.5/-54.3
12600/2333	55.5/-12.2	38.7/-3.7	96.6/-10.3	45.1/-33.7	34.80/-70.3	21.4/-55.4

Table 3 Strain gage location and results from experiments for face-hobbed spiral bevel gears

RPM/load, in.·lb, pinion	Fillet gage stress, ksi Maximum/Minimum		Root gage stress, ksi Maximum/Minimum		
	Heel	Heel	Toe	Mid	Heel
7200/1470	46.9/-7.2	40.4/-4.0	24.2/-24.3	23.8/-34.7	20.3/-34.3
10800/1540	47.0/-7.4	41.8/-3.5	28.9/-28.7	25.9/-34.3	18.9/-36.4
11000/2377	76.1/-9.8	63.9/-5.2	35.6/-33.3	35.3/-42.8	30.2/-51.9
12600/2380	74.9/-11.1	63.9/-5.7	36.1/-32.1	37.5/-41.2	32.3/-55.8

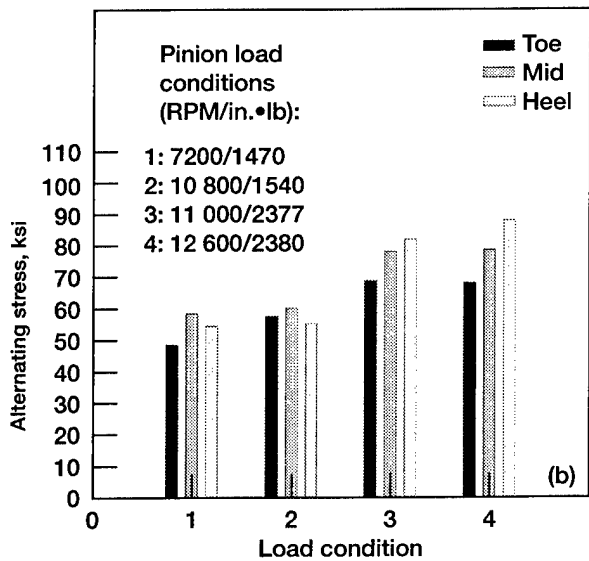
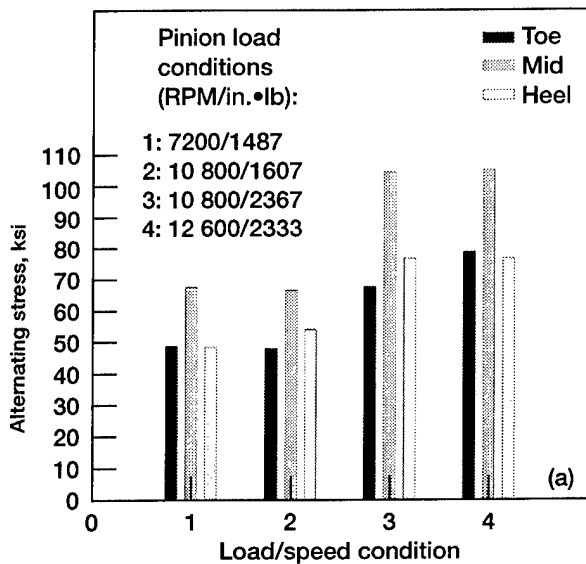

Figure 8.—Comparison of root gauge alternating stress magnitude across the face width of the two different pinions. (a) Face-milled. (b) Face-hobbed.

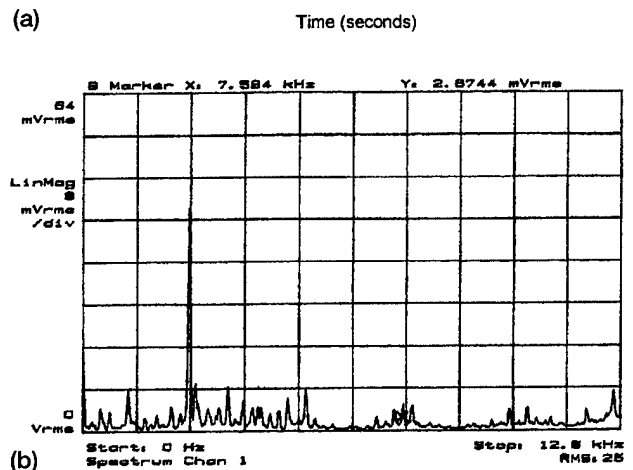
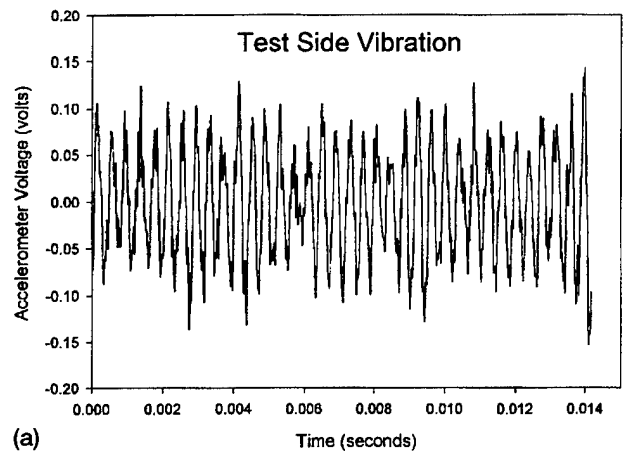

Figure 9.—Typical (a) time averaged variation [time domain], and (b) FFT spectrum (frequency domain). Conditions shown were for 12 600 RPM, 2373 in.·lb torque.

Table 4 Vibration results from the gear meshing frequencies

Face-milled vibration, g's			Face-hobbed vibration, g's		
Rpm/load, in.·lb, pinion	1 <sup>st</sup>	2 <sup>nd</sup>	Rpm/load, in.·lb, pinion	1 <sup>st</sup>	2 <sup>nd</sup>
7200/1580	1.8	2.9	7200/1470	0.6	0.5
10800/1567	2.5	4.7	10800/1540	2.2	0.8
<sup>a</sup> 10800/2380	4.8	3.8	11100/2377	2.6	1.0
<sup>a</sup> 12600/2373	8.0	0.2	12600/2380	4.3	1.7

<sup>a</sup>Result attained at the point when scoring had initiated.

root gages from the two different gear types is shown in Fig. 8. The magnitude of the alternating stress absolute values is presented. As can be seen from this figure, the face-milled gear type produced the highest alternating stress at the mid-face position, and the face-hobbed gear type produced the highest alternating stress at the heel position at the highest torque conditions. The maximum alternating stress value of the face-hobbed pinion was at least 10% less than that of the face-milled pinion at all conditions.

#### Vibration Results

During testing vibration data was taken and recorded when possible on tape for future analysis. As mentioned earlier, the accelerometers were located on the pinion support housings directly above the pinions on both sides of the test facility. An example of the data first time synchronously averaged is shown in Fig. 9(a) (one revolution of the gear, 36 pulses) and a frequency spectrum of the same data is shown in Fig. 9(b). As can be seen from the data, the gear meshing frequency dominated the vibration. The frequency spectrum used a Hanning window and was constructed from 25 averages. The data from the conditions tested is shown in Table 4. All data was taken from the test side vibration where the pinion drives the gear in the normal speed reducer mode. The first or fundamental meshing frequency and the next harmonic are presented. From the table the data indicates that the face-milled gears produced higher vibration for similar conditions at the fundamental meshing frequency. The face-milled hardware however had begun to have a surface scoring damage at the two higher speed and load conditions. Both gear types indicated a trend of increasing vibration with the power delivered through the gear mesh. The peak loading condition was at 353 kW (474 hp).

#### Noise Results

The noise results were attained using a hand-held sound level meter. The sound level meter was held ~15 cm (6 in.) from the lexan cover of each side of the test facility and the maximum value noted. The sound level meter was set to the

Table 5 Results from noise measurements

Face-milled noise, test side, dB's		Face-hobbed noise, test side, dB's	
Rpm/load, in.·lb, pinion		Rpm/load, in.·lb, pinion	
Lube pumps	86	Lube pumps	88.2
7200/1580	107	7200/1470	100
10800/1567	111	10800/1540	103
<sup>a</sup> 10800/2380	115	11100/2377	103
<sup>a</sup> 12600/2373	110	12600/2380	106

<sup>a</sup>Result attained at the point when scoring had initiated.

A-weighted scale. The results from the two different gear mesh types are shown in Table 5. First the background noise from the facility lube and vacuum pumps in operation were measured. Then during operation of the facility the other conditional results were noted. For the two conditions prior to the face-milled gears starting to score the face-milled gears produced higher levels of noise. When the parts scored and at the 10800 rpm and 269 N·m (2380 in.·lb) conditions, the noise level difference was the highest. Note that this is a condition that coincides with a facility vibration mode and the face-hobbed parts were run at a slightly higher speed to avoid the facility mode. Had the face-hobbed gears been run at the same conditions (speed) the noise result produced would have been higher and may have approached the face-milled hardware at this speed condition.

#### DISCUSSION OF RESULTS

Based on the limited amount of data attained in the study conducted, there is no reason to believe that face-hobbed gears could not perform at least as good as the current ground face-milled bevel gears used in aerospace applications. While no long-term tests were conducted in this study (fatigue), the operational characteristics indicated that this manufacturing technique may be suitable. While the data was all favorable from the face-hobbed test hardware, this is still only a single application. Since manufacturing costs should be reduced for the face-hobbed test hardware spiral bevel gears, due to the reduction in time to manufacture and number of machines required to complete the part, cost reduction without performance degradation should be attainable.

#### CONCLUSIONS

A study to compare face-milled and face-hobbed spiral bevel gears for aerospace application was accomplished. Based on the initial results attained in this study the following general conclusions can be drawn:

- Root stress results were similar with respect to maximum positive bending; however the alternating stress was higher in the face-milled pinion than that attained with the face-hobbed pinion.
- Root stress distribution was slightly different with the face-milled gears having a greater variation across the face width.
- Face-hobbed gears had a lower vibration and noise characteristics when compared to face-milled gears. However at two of the conditions the face-milled components had begun to score.

## REFERENCES

1. Oswald, F.: Gear Tooth Stress Measurements of the UH-60A Helicopter Transmission. NASA TP-2698, 1987.
2. Frint, H.: Automated Inspection and Precision Grinding of Spiral Bevel Gears. NASA CR-4083, AVSCOM TR-87-C-11, July, 1987.
3. Scott, H.W.: Computer Numerical Controlled Grind of Spiral Bevel Gears. NASA CR-187175, AVSCOM-TR-90-F-6, August 1991.
4. Handschuh, R., and Bill, R.: Recent Manufacturing Advances for Spiral Bevel Gears. NASA TM-104479, AVSCOM TR-91-C-022, September 1991.
5. Handschuh, R., and Kicher, T.: A Method for Thermal Analysis of Spiral Bevel Gears, NASA TM-106612, ARL-TR-457, September 1994.
6. Handschuh, R. and Bibel, G.: Comparison of Experimental and Analytical Tooth Bending Stress of Aerospace Spiral Bevel Gears, NASA TM-1999-208903, ARL-TR-1891, February 1999.
7. Lewicki, D., Handschuh, R., Henry, Z., and Litvin, F.: Low-Noise, High-Strength, Spiral Bevel Gears for Helicopter Transmissions, Journal of Propulsion and Power, Vol. 10, no. 3, 1994.
8. Litvin, F., Wang, A., Handschuh, R., Lewicki, D., and Henry, Z.: Design, Geometry, Stress Analysis and Test of Low-Noise, Improved Strength, Face-Milled Spiral Bevel Gears, AGMA, 97FTM15, November 1997.
9. Henry, Z.: Bell Helicopter Advanced Rotorcraft Transmission (ART) Program, NASA CR-195479, ARL-CR-238, June 1995.
10. Hohn, B.-R., Winter, H., Michaelis, K., and Volhuter, F.: Pitting Resistance and Bending Strength of Bevel and Hypoid Gear Teeth, Proceedings of the 6<sup>th</sup> International Power Transmission and Gearing Conference, September 1992.
11. Stadtfeld, H.: *Handbook of Bevel and Hypoid Gears*, Rochester Institute of Technology, College of Engineering, 1993.
12. Stadtfeld, H.: *Advanced Bevel Gear Technology*, The Gleason Works, Rochester, New York, 2000.

# REPORT DOCUMENTATION PAGE

Form Approved  
OMB No. 0704-0188

Public reporting burden for this collection of information is estimated to average 1 hour per response, including the time for reviewing instructions, searching existing data sources, gathering and maintaining the data needed, and completing and reviewing the collection of information. Send comments regarding this burden estimate or any other aspect of this collection of information, including suggestions for reducing this burden, to Washington Headquarters Services, Directorate for Information Operations and Reports, 1215 Jefferson Davis Highway, Suite 1204, Arlington, VA 22202-4302, and to the Office of Management and Budget, Paperwork Reduction Project (0704-0188), Washington, DC 20503.

<b>1. AGENCY USE ONLY (Leave blank)</b>		<b>2. REPORT DATE</b> October 2001	<b>3. REPORT TYPE AND DATES COVERED</b> Technical Memorandum	
<b>4. TITLE AND SUBTITLE</b>  Experimental Comparison of Face-Milled and Face-Hobbed Spiral Bevel Gears			<b>5. FUNDING NUMBERS</b>  WU-712-30-13-00 1L162211A47A	
<b>6. AUTHOR(S)</b>  Robert F. Handschuh, Michael Nanlawala, John M. Hawkins, and Danny Mahan				
<b>7. PERFORMING ORGANIZATION NAME(S) AND ADDRESS(ES)</b> National Aeronautics and Space Administration John H. Glenn Research Center Cleveland, Ohio 44135-3191 and U.S. Army Research Laboratory Cleveland, Ohio 44135-3191			<b>8. PERFORMING ORGANIZATION REPORT NUMBER</b>  E-12793	
<b>9. SPONSORING/MONITORING AGENCY NAME(S) AND ADDRESS(ES)</b> National Aeronautics and Space Administration Washington, DC 20546-0001 and U.S. Army Research Laboratory Adelphi, Maryland 20783-1145			<b>10. SPONSORING/MONITORING AGENCY REPORT NUMBER</b>  NASA TM-2001-210940 ARL-TR-1104	
<b>11. SUPPLEMENTARY NOTES</b> Prepared for the International Conference on Motion and Power Transmission sponsored by the Japan Society of Mechanical Engineers, Fukuoka, Japan, November 15-17, 2001. Robert F. Handschuh, U.S. Army Research Laboratory, NASA Glenn Research Center; Michael Nanlawala, Illinois Institute of Technology, IITRI, Chicago, Illinois; John M. Hawkins Rolls-Royce Corporation, Indianapolis, Indiana; and Danny Mahan, U.S. Army AMCOM, Redstone Arsenal, Huntsville, Alabama. Responsible person, Robert F. Handschuh, organization code 0300, 216-433-3969.				
<b>12a. DISTRIBUTION/AVAILABILITY STATEMENT</b>  Unclassified - Unlimited Subject Category: 37  Available electronically at <a href="http://gltrs.grc.nasa.gov/GLTRS">http://gltrs.grc.nasa.gov/GLTRS</a> This publication is available from the NASA Center for AeroSpace Information, 301-621-0390.			<b>12b. DISTRIBUTION CODE</b>	
<b>13. ABSTRACT (Maximum 200 words)</b>  An experimental comparison of face-milled and face-hobbed spiral bevel gears was accomplished. The two differently manufactured spiral bevel gear types were tested in a closed-loop facility at NASA Glenn Research Center. Strain, vibration, and noise testing were completed at various levels of rotational speed and load. Tests were conducted from static (slow-roll) to 12600 rpm and up to 269 N•m (2380 in.•lb) pinion speed and load conditions. The tests indicated that the maximum stress recorded at the root locations had nearly the same values, however the stress distribution was different from the toe to the heel. Also, the alternating stress measured was higher for the face-milled pinion than that attained for the face-hobbed pinion (larger minimum stress). The noise and vibration results indicated that the levels measured for the face-hobbed components were less than those attained for the face-milled gears tested.				
<b>14. SUBJECT TERMS</b>  Gears; Transmissions			<b>15. NUMBER OF PAGES</b> 14	
			<b>16. PRICE CODE</b>	
<b>17. SECURITY CLASSIFICATION OF REPORT</b> Unclassified	<b>18. SECURITY CLASSIFICATION OF THIS PAGE</b> Unclassified	<b>19. SECURITY CLASSIFICATION OF ABSTRACT</b> Unclassified	<b>20. LIMITATION OF ABSTRACT</b>	