

NRL MR-5084

**On The Design of an Optimal Waveform to
Maximize Scattering from a Flat Plate
And a Cone**

J.K. Hsiao
Naval Research Laboratory

June 10, 1983



Approved for public release, distribution unlimited

**Reproduced From
Best Available Copy**

20020206 129

REPORT DOCUMENTATION PAGE		READ INSTRUCTIONS BEFORE COMPLETING FORM
1. REPORT NUMBER NRL Memorandum Report 5084	2. GOVT ACCESSION NO.	3. RECIPIENT'S CATALOG NUMBER
4. TITLE (and Subtitle) ON THE DESIGN OF AN OPTIMAL WAVEFORM TO MAXIMIZE SCATTERING FROM A FLAT PLATE AND A CONE	5. TYPE OF REPORT & PERIOD COVERED Interim report on a continuing NRL problem.	
	6. PERFORMING ORG. REPORT NUMBER	
7. AUTHOR(s) J.K. Hsiao	8. CONTRACT OR GRANT NUMBER(s)	
9. PERFORMING ORGANIZATION NAME AND ADDRESS Naval Research Laboratory Washington, D.C. 20375	10. PROGRAM ELEMENT, PROJECT, TASK AREA & WORK UNIT NUMBERS 62712N; SF12131691; 53-0611-0-0	
11. CONTROLLING OFFICE NAME AND ADDRESS Naval Sea Systems Command Washington, D.C. 20362	12. REPORT DATE June 10, 1983	
	13. NUMBER OF PAGES 10	
14. MONITORING AGENCY NAME & ADDRESS (if different from Controlling Office)	15. SECURITY CLASS. (of this report) UNCLASSIFIED	
	15a. DECLASSIFICATION/DOWNGRADING SCHEDULE	
16. DISTRIBUTION STATEMENT (of this Report) Approved for public release; distribution unlimited.		
17. DISTRIBUTION STATEMENT (of the abstract entered in Block 20, if different from Report)		
18. SUPPLEMENTARY NOTES		
19. KEY WORDS (Continue on reverse side if necessary and identify by block number) Radar cross section Scattering		
20. ABSTRACT (Continue on reverse side if necessary and identify by block number) In this report we have reviewed the general scattering problem. We first treated the problem of scattering of a perfect conducting plate. It was shown that in order to have any significant energy reflected in a direction other than the direction predicted by geometrical optics, the plate size must be of the same order as the wavelength of the incident wave. However, under this condition, the edge effect may be dominant. We also reviewed the required waveform which may yield high back scattering from a cone. By the use of impulse responses, it was shown that a constant pulse without modulation has the maximum back scattering.		

CONTENTS

INTRODUCTION	1
SCATTERING FIELD	1
SCATTERING FIELD OF A FLAT PLATE	4
BACKSCATTERING FROM A CONE	5
CONCLUSION	7
REFERENCE	7

ON THE DESIGN OF AN OPTIMAL WAVEFORM TO MAXIMIZE SCATTERING FROM A FLAT PLATE AND A CONE

1. INTRODUCTION

It is well known that a cone or a flat plate has very small radar cross section, except that it may have a specular reflection in a certain direction. The question is whether it is possible to design a waveform that may yield a maximum reflection from a cone or a flat metal plate in a desired direction. This report examines such a possibility. To simplify the problem, the edge effect and creeping waves are neglected. We first review the general scattering problem of a flat plate and a cone.

2. SCATTERING FIELD

The discussion of the scattering problem will be restricted to the case of an obstacle of infinite conductivity. The problem with which we are concerned is the following: Given a primary system of sources that produce an electromagnetic field E_1, H_1 ; an infinite conducting body is introduced into the field and it is required to find the new field E, H . The solution to our problem is based on the superposition principle. On introducing the body into the field of the sources a distribution of current and charge is induced over its surface. We then have two component fields; one arising from the induced distribution over the body and the second arising from the currents and charges in the source system. The total E, H results from the superposition of the component fields. The interaction between the body and the source system - and the total field E, H - can be analyzed as a superposition of multiple scattering processes. First we consider the interaction of the body with the original field E_1, H_1 , assuming no change in the source currents. The body sets up scattered fields, E_s, H_s arising from an induced distribution over its surface. The scattered wave falling on the source-system conductors induces a current distribution that gives rise to a secondary scattered field E_1', H_1' . The interaction of the secondary field with the body is again a scattering process leading to an induced distribution over the body and a scattered field E_s', H_s' , and so on. The total induced distribution over the body is the sum of the distribution associated with the component scattered waves $E_s, E_s' \dots$, and the resultant distribution in the source system is the sum of the distributions associated with $E_1, E_1' \dots$, respectively. If the distance R between the source system and the body is large compared with the dimensions of either, the scattering processes of order higher than the first can generally be neglected; for example, in general the ratio $|E_1'|/|E_1|$ evaluated at the body is of the order $1/R^2$, and the ratio $|E_1''|/|E_1|$ is of the order $1/R^4$. This condition is usually met in our examples, and the multiple scattering will be neglected in the following study. With attention restricted to a single scattering process, our problem is that of finding the scattered field E_s, H_s set up by an infinite conducting body

when it is introduced into an initial field E_i, H_i ; the total field is then

$$\vec{E} = \vec{E}_i + \vec{E}_s \quad (1a)$$

$$\vec{H} = \vec{H}_i + \vec{H}_s \quad (1b)$$

Let S be the scattering body; \vec{n} is unit vector normal to the boundary surface of the body S , directed outward into the surrounding space. Since the conductivity of the body is infinite, the total field E, H is zero everywhere inside the body S ; that is

$$\vec{E}_s = \vec{E}_i \quad (2a)$$

$$\vec{H}_s = -\vec{H}_i \quad (2b)$$

Boundary conditions require that on the surface of the scattering body

$$\vec{n} \times \vec{E} = 0 \quad (3a)$$

$$\vec{n} \cdot \vec{H} = 0 \quad (3b)$$

One thus has

$$\vec{n} \times \vec{E}_s = -\vec{n} \times \vec{E}_i \quad (4a)$$

$$\vec{n} \cdot \vec{H}_s = -\vec{n} \cdot \vec{H}_i. \quad (4b)$$

The surface current is

$$\vec{J} = \vec{n} \times \vec{H}. \quad (5)$$

The vector potential \vec{A} is related to the surface current density J by the following relation

$$\vec{A} = \mu_0 \int_S \vec{J}(r') \frac{\exp(jk_0 R)}{4\pi R} ds \quad (6)$$

where r' is a position vector of current density J and R is the distance from a current element to the field point,

$$R = |\vec{r} - \vec{r}'| \quad (7)$$

as shown in Fig. (1), and,

$$k_0 = 2\pi/\lambda$$

is the wave number.

$$\text{Since } \vec{H} = \frac{1}{\mu_0} \nabla \times \vec{A} \quad (8)$$

one has

$$\vec{H}_s = - \int_S \vec{J} \times \nabla \frac{\exp(jk_0 R)}{4\pi R} ds. \quad (9)$$

According to Maxwell's equations in a source free region,

$$\vec{E} = \frac{-1}{j\omega\epsilon_0} \nabla \times \vec{H} \quad (10)$$

$$\vec{E}_s = \frac{-1}{j\omega\epsilon_0} \int_s \nabla \times \left[\vec{J} \times \nabla \frac{\exp(jk_0 R)}{4\pi R} \right] ds. \quad (11)$$

One can show that, in a far zone region,

$$R = |\vec{r} - \vec{r}'| \\ \approx r - \hat{r} \cdot \vec{r}'$$

$$\frac{\exp(jk_0 R)}{R} = \frac{1}{r} \exp[jk_0 (\hat{r} \cdot \vec{r}')]$$

where \hat{r} is a unit vector in the \vec{r} direction, and

$$\frac{1}{r} \left[\exp jk_0 (\hat{r} \cdot \vec{r}') \right] \approx \frac{-jk_0}{r} \exp(-jk_0 r) \exp(jk_0 \hat{r} \cdot \vec{r}') \hat{r} \quad (12)$$

Inserting this relation into equation (9), we obtain

$$\vec{H}_s = \frac{jk_0}{4\pi r} \exp(-jk_0 r) \int_s \vec{J} \times \hat{r} \exp(jk_0 \hat{r} \cdot \vec{r}') ds. \quad (13)$$

Similarly one can show

$$\vec{E}_s = \frac{j\omega\mu}{4\pi r} \exp(-jk_0 r) \int_s \left[(\hat{r} \cdot \vec{J}) \hat{r} - \vec{J} \right] \exp(jk_0 \hat{r} \cdot \vec{r}') ds. \quad (14)$$

Accordingly to the boundary condition of eq. (4a) one finds

$$-\hat{n} \times \vec{E}_i = \frac{j\omega\mu}{4\pi r} \exp(-jk_0 r) \int_s \hat{n} \times \left[(\hat{r} \cdot \vec{J}) \hat{r} - \vec{J} \right] \exp(jk_0 \hat{r} \cdot \vec{r}') ds. \quad (15)$$

Since the incident field \vec{E}_i is known for a given field point, the only unknown in this equation is the current density \vec{J} . Thus, if this integral equation is solved, one can find the current density \vec{J} which in turn will determine the scattered field \vec{E}_s and \vec{H}_s . Solving this integral equation in general is not easy. Many approximate methods have been implemented. One of the most interesting approaches is that of geometrical optics. The geometrical-optics method can furnish no information on the structure of the scattered field and that results from deviations from geometrical propagation of the reflected wavefront. By geometrical optics this wave is discontinuous (geometrical shadow behind the reflector), and it is well known that in the presence of a discontinuity geometrical optics does not give accurate results. The deviations decrease in significance as the wavelength goes to zero; the geometrical-optics method is to be regarded as a zero wavelength approximation to the scattered field.

The current-distribution method which will be formulated in this section leads to a better approximation for the scattered field and also makes possible the analysis of secondary effects such as the reaction of the reflector on the sources. The cardinal feature of the method is that it attempts to approximate the current distribution over the surface of the reflector; the scattered field is obtained from the current distribution by Eqs. (13) and (14) and is thus an electromagnetic field that satisfies Maxwell's equations. We shall be interested primarily in the far-zone field of the current distribution in obtaining the composite pattern of the reflector and the sources.

The current distribution over the reflector is obtained on the basis of geometrical optics, which can be expected to yield good results only if the reflector is far enough from the sources for the field of these to be described adequately in terms of wavefronts and rays. On the basis of ray optics there is a sharply defined shadow region behind the reflector in which the total field is equal to zero. According to the boundary condition, since the total field is zero, the current distribution over the shadow area is zero. It is a matter of experience that the shadow region is more sharply defined the smaller the wavelength and the larger the ratio of the reflector dimensions to the wavelength. The first assumption of our approximation technique, then, is that there is not current over the shadow area of the reflector. The current distribution over the illuminated region of S is obtained on the assumption that at every point the incident field is reflected as though an infinite plane wave were incident on the infinite tangent plane. Let \vec{E}_i , \vec{E}_r again be the initial field; let \vec{s}_0 be a unit vector in the direction of the Poynting vector, that is, along the incident ray. If \vec{n} is the unit vector normal to the surface at the point of incidence and \vec{s}_1 a unit vector in the direction of the reflected ray, the surface current density is

$$\begin{aligned} \vec{J} &= 2 (\vec{n} \times \vec{H}_i) \\ &= 2 \left(\frac{\epsilon_0}{\mu_0} \right)^{1/2} \vec{n} \times \vec{s}_0 \times \vec{E}_i \end{aligned} \quad (16)$$

where ϵ_0 and μ_0 are respectively the permittivity and permeability of the medium.

It is evident that the assumption of this approach is that the radii of curvature of the incident wavefront are large compared with the wavelength as are also the radii of curvature of the reflector. Our problem seems to meet all these conditions.

3. SCATTERING FIELD OF A FLAT PLATE

Let a flat plate lie in the x - y plane as shown in Figure 2. Let this plate have an infinite length in the y -direction, this then simplifies this problem to one-dimension. The length of the plate in the x direction is assumed to be $2L$. Let a plane wave propagate in the \vec{s}_0 direction as shown in Figure 2. Assumed that the incident E -field is linearly polarized in the \vec{y} -direction and

$$\vec{E}_i = E \vec{y} \quad (17a)$$

$$E = \exp \left[-j\omega t + j2\pi \frac{x}{\lambda} \sin \theta_0 \right] \quad (17b)$$

where θ_0 is the angle between \vec{S}_0 and the normal of the boundary. This angle is positive when it is clockwise. In our example this θ_0 is negative. According to eq. (16) the current density is

$$\vec{J} = 2 \left(\frac{\epsilon_0}{\mu_0} \right)^{1/2} \cos \theta_0 \hat{y}. \quad (18)$$

Consider a far zone field point along the \vec{S}_1 direction which is an angle θ_1 with respect to the normal. The reflected E-field, according to Eq. (14) is:

$$\vec{E}_s = \frac{j\omega\mu}{2\pi r} \exp(-jk_0 r) \int_{-L}^L \left(\frac{\epsilon_0}{\mu_0} \right)^{1/2} \cos \theta_0 \hat{y} \cdot \exp \left[-j\omega t + 2\pi x / \lambda (\sin \theta_0 + \sin \theta_1) \right] dx \quad (19)$$

where r is the distance from the origin (or reference point) to the field point. Integrating Eq. (19) one finds.

$$\vec{E}_s = \frac{\cos \theta_0}{\pi r} \exp(-j\omega t - jk_0 r) \cdot \frac{\sin 2\pi L / \lambda (\sin \theta_0 + \sin \theta_1)}{(\sin \theta_0 + \sin \theta_1)} \hat{y} \quad (20)$$

Several interesting points may be drawn from this result.

(a) The reflected wave is also linearly polarized.

(b) The \vec{E}_s has a maximum magnitude along a direction $\theta_1 = -\theta_0$.

(c) when $L/\lambda = \infty$, the \vec{E}_s becomes an impulse function all its energy will be reflected at a direction $\theta_1 = -\theta_0$. This is exactly what geometrical optics predicts.

(d) In order to achieve any significant level of scattering energy along a direction other than $\theta_1 = -\theta_0$, the dimension L must be in the same order as that of the wavelength λ . However, in that case, the edge effect must be taken into account which has been neglected in this analysis. From this one may conclude that for a flat plate which has a much greater dimension than the wavelength of the incident wave, the reflected wave has maximum energy along the direction $\theta_1 = -\theta_0$ as geometrical optics predicts. Negligible energy will be scattered at any other direction. To achieve scattering energy at any other direction, the wavelength of the incident wave must be in the same order as that of the plate size. In that case, the edge effect will be dominant. Hence, one must use this edge effect to design a waveform to achieve a maximum scattering at a desired direction.

4. BACKSCATTERING FROM A CONE

The analysis presented here follows very close Kennaugh's work⁽¹⁾. Let a cone have its axis along z axis as shown in Fig. 3. Since this cone is symmetrical, this problem is essentially two-dimensional.

A surface current distribution \vec{J} over the surface S shown in Fig. 3 produces a radiated field intensity E_s at large distance r along the negative z axis, given by

$$E_s = -\frac{j\omega\mu}{4\pi r} \exp[j(\omega t - k_0 r)] \int_S (\vec{J} \cdot \hat{x}) \exp(-2jk_0 z) ds \quad (21)$$

Let the incident wave be polarized in the x direction such that:

$$\vec{E}_i = \exp[j(\omega t - k_0 z)] \hat{x}. \quad (22)$$

According to Eq. (16)

$$\vec{J} = 2 \left(\frac{\epsilon_0}{\mu_0}\right)^{1/2} \exp[j(\omega t - k_0 z)] \hat{n} \times \hat{y} \quad (23)$$

where \hat{n} is a unit vector normal to the surface S (see Fig. 3). The E_s then becomes

$$\begin{aligned} E_s(j\omega) &= \frac{j\omega}{2\pi r c} \exp(j\omega t - jk_0 r) \int_S \hat{x} \cdot \hat{n} \exp(-2jk_0 z) ds \\ &= \frac{-j\omega}{2\pi r c} \exp(j\omega t - jk_0 r) \int_S \hat{z} \cdot \hat{n} \exp(-2jk_0 z) ds. \end{aligned} \quad (24)$$

Now $\hat{z} \cdot \hat{n} ds = -dA_z$, where A_z is the projection of the scatterer surface between $z=0$ and a cutting plane at z upon xy plane, it follows

$$E_s(j\omega) = \frac{j\omega}{2\pi r c} \exp(j\omega t - jk_0 r) \int_{0-}^{l+} \exp(-2j\omega z/c) \left(-\frac{dA_z}{dz}\right) dz. \quad (25)$$

Since $\frac{dA_z}{dz} = 0$, at $z=0-$ and $z=l+$ and when integrating by parts, one finds

$$E_s(j\omega) = \frac{e^{-jk_0 r}}{4\pi r} \exp(j\omega t) \int_{0-}^{l+} \exp(-2j\omega z/c) \frac{d^2 A_z}{dz^2} dz \quad (26)$$

Let $t' = 2z/c$

$$\begin{aligned} E_s(j\omega) &= \frac{c}{2} \frac{e^{-jk_0 r}}{4\pi r} \exp(j\omega t) \int_{0-}^{l+} e^{-j\omega t'} \frac{d^2 A_z}{dz^2} dt' \\ &= \frac{c}{2} \frac{e^{-jk_0 r}}{4\pi r} \exp(j\omega t) \cdot F(j\omega) \end{aligned} \quad (27)$$

If one treats this scattering process as a filter problem then $P(j\omega)$ represents the frequency response of this filter. The impulse response of this filter is then $\frac{d^2 A_z}{dz^2}$.

For a cone with circular cross section

$$A_z = \pi \tan^2 \alpha z^2$$

$$\frac{d^2 A_z}{dz^2} = 2\pi \tan^2 \alpha \quad (28)$$

The output of a filter is the convolution product of the impulse response and the signal applied to the filter, thus

$$p(t) = \int s(t-\tau) f(\tau) d\tau \quad (29)$$

where $S(t)$ is the signal and $f(t)$ is the impulse response of the filter. The power output is then

$$|P(t)|^2 = \left| \int S(t-\tau) f(\tau) d\tau \right|^2 \quad (30)$$

and according to Schwartz's inequality

$$|P(t)|^2 \leq \int |S(t-\tau)|^2 d\tau \cdot \int |f(\tau)|^2 d\tau. \quad (31)$$

Therefore, the maximum power output occurs when

$$S(-\tau) = f(\tau). \quad (32)$$

Since $f(\tau)$ in our example is a constant, the optimal signal is then a constant pulse with no modulation. One should notice that in the above derivation, the effect of discontinuity at the tip and end of the cone is ignored.

5. CONCLUSION

In this report we have reviewed the general scattering problem. The scattered field can be computed from the current distribution on the scattering body. However, it is required to solve an integration equation in order to determine this current distribution. One simplified method is to use geometrical optics to approximate the current distribution on the scattering body when certain conditions are met. This approach is then used to find the scattered field when incident waves are reflected from a conducting flat plate. It is shown that in order to have any energy reflect in a direction other than the direction predicted by geometrical optics, the plate size must be of the same order as the wavelength of the incident wave. However, under this condition, the edge effect may be dominant. We also reviewed the required waveform which may yield high back scattering from a cone. By use of impulse approach, it showed that a constant pulse without modulation has the maximum backscattering.

6. REFERENCE

- (1) E.M. Kennaugh and D.L. Moffatt, "Transient and Impulse Response Approximation", Proceedings of IEEE, August 1965.

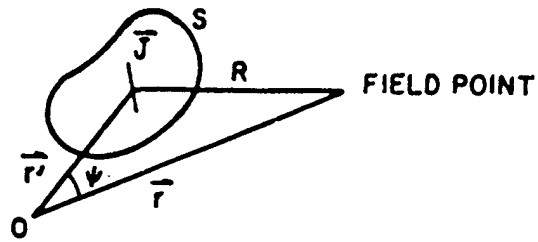

Fig. 1 — An arbitrary current source

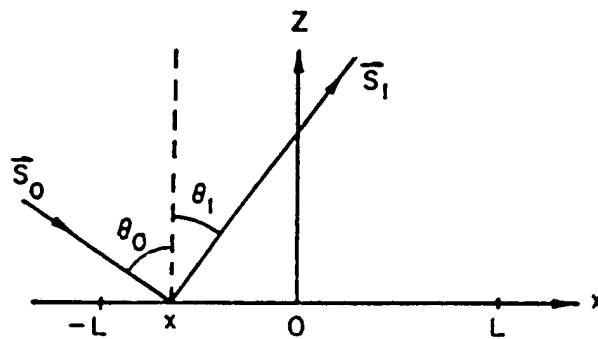

Fig. 2 — Incident and reflected plane wave

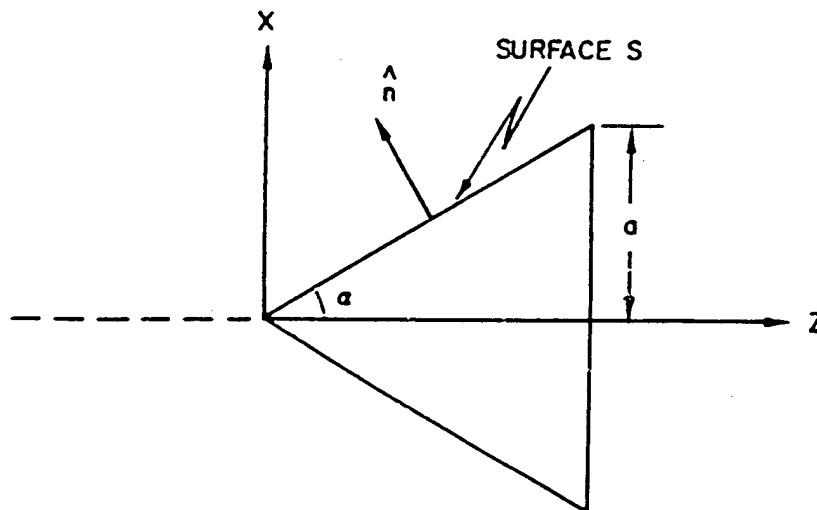

Fig. 3 — Geometry of a flat cone