

---

# ELECTROMAGNETIC CODE CONSORTIUM BENCHMARKS

Andrew Greenwood

December 2001

Final Report

APPROVED FOR PUBLIC RELEASE; DISTRIBUTION IS UNLIMITED.

20020213 127



**AIR FORCE RESEARCH LABORATORY**  
**Directed Energy Directorate**  
**3550 Aberdeen Ave SE**  
**AIR FORCE MATERIEL COMMAND**  
**KIRTLAND AIR FORCE BASE, NM 87117-5776**

---

AFRL-DE-TR-2001-1086

Using Government drawings, specifications, or other data included in this document for any purpose other than Government procurement does not in any way obligate the U.S. Government. The fact that the Government formulated or supplied the drawings, specifications, or other data, does not license the holder or any other person or corporation; or convey any rights or permission to manufacture, use, or sell any patented invention that may relate to them.

This report has been reviewed by the Public Affairs Office and is releasable to the National Technical Information Service (NTIS). At NTIS, it will be available to the general public, including foreign nationals.

If you change your address, wish to be removed from this mailing list, or your organization no longer employs the addressee, please notify AFRL/DEHE, 3550 Aberdeen Ave SE, Kirtland AFB, NM 87117-5776.

Do not return copies of this report unless contractual obligations or notice on a specific document requires its return.

This report has been approved for publication.

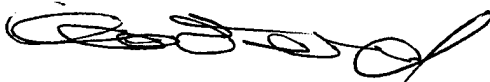

ANDREW D. GREENWOOD  
Project Manager

FOR THE COMMANDER



MICHAEL J. WALKER, Maj, USAF  
Chief, HPM Effects and Models Branch



R. EARL GOOD, SES  
Director, Directed Energy

# REPORT DOCUMENTATION PAGE

Form Approved  
OMB No. 0704-0188

Public reporting burden for this collection of information is estimated to average 1 hour per response, including the time for reviewing instructions, searching existing data sources, gathering and maintaining the data needed, and completing and reviewing this collection of information. Send comments regarding this burden estimate or any other aspect of this collection of information, including suggestions for reducing this burden to Department of Defense, Washington Headquarters Services, Directorate for Information Operations and Reports (0704-0188), 1215 Jefferson Davis Highway, Suite 1204, Arlington, VA 22202-4302. Respondents should be aware that notwithstanding any other provision of law, no person shall be subject to any penalty for failing to comply with a collection of information if it does not display a currently valid OMB control number. PLEASE DO NOT RETURN YOUR FORM TO THE ABOVE ADDRESS.

<b>1. REPORT DATE (DD-MM-YYYY)</b> 05-12-2001		<b>2. REPORT TYPE</b> Final		<b>3. DATES COVERED (From - To)</b> 01-06-2001 to 05-12-2001	
<b>4. TITLE AND SUBTITLE</b> Electromagnetic Code Consortium Benchmarks				<b>5a. CONTRACT NUMBER</b>	
				<b>5b. GRANT NUMBER</b>	
				<b>5c. PROGRAM ELEMENT NUMBER</b> 62605F	
<b>6. AUTHOR(S)</b> Andrew Greenwood				<b>5d. PROJECT NUMBER</b> 4867	
				<b>5e. TASK NUMBER</b> HM	
				<b>5f. WORK UNIT NUMBER</b> 01	
<b>7. PERFORMING ORGANIZATION NAME(S) AND ADDRESS(ES)</b> AFRL/DEHE 3550 Aberdeen Ave SE Kirtland AFB, NM 87117-5776				<b>8. PERFORMING ORGANIZATION REPORT NUMBER</b> AFRL-DE-TR-2001-1086	
<b>9. SPONSORING / MONITORING AGENCY NAME(S) AND ADDRESS(ES)</b>				<b>10. SPONSOR/MONITOR'S ACRONYM(S)</b>	
				<b>11. SPONSOR/MONITOR'S REPORT NUMBER(S)</b>	
<b>12. DISTRIBUTION / AVAILABILITY STATEMENT</b> Approved for public release; distribution is unlimited.					
<b>13. SUPPLEMENTARY NOTES</b>					
<b>14. ABSTRACT</b> Several additions to the metallic Electromagnetic Code Consortium (EMCC) benchmarks are described. The new geometries include a cube, a prism, a pyramid and a trihedron. These geometries include edge, corner, and multipath scattering effects. In addition, the first EMCC antenna benchmark composed of an array of elements on a finite metal plate is described. Measured and computed scattering or radiation data for each new geometry is shown. Computed data is generated with the FISC, AIM, and XPATCH codes. Where applicable, sources of discrepancy between the measured and computed results are discussed. For some of the objects, the measured data is taken in two passes to improve the dynamic range. However, at present only one pass of the data is available, resulting in some error near the top or the bottom of the data range.					
<b>15. SUBJECT TERMS</b> Computational electromagnetics, benchmarks					
<b>16. SECURITY CLASSIFICATION OF:</b>			<b>17. LIMITATION OF ABSTRACT</b> Unlimited	<b>18. NUMBER OF PAGES</b> 18	<b>19a. NAME OF RESPONSIBLE PERSON</b> Andrew Greenwood
<b>a. REPORT</b> Unclassified	<b>b. ABSTRACT</b> Unclassified	<b>c. THIS PAGE</b> Unclassified			<b>19b. TELEPHONE NUMBER (include area code)</b> 505-846-6642



# Contents

<b>1</b>	<b>Introduction</b>	<b>1</b>
<b>2</b>	<b>NRL Problems</b>	<b>1</b>
2.1	Cube . . . . .	1
2.2	Prism . . . . .	2
2.3	Pyramid . . . . .	4
<b>3</b>	<b>Trihedron</b>	<b>4</b>
<b>4</b>	<b>Antenna Array</b>	<b>8</b>
<b>5</b>	<b>Conclusion</b>	<b>9</b>

## List of Figures

1	Picture of the cube. . . . .	2
2	RCS of the cube . . . . .	3
3	Picture of the prism. . . . .	4
4	RCS of the prism . . . . .	5
5	Picture of the pyramid. . . . .	6
6	RCS of the pyramid . . . . .	6
7	Picture of the trihedron. . . . .	7
8	RCS of the trihedron . . . . .	7
9	Picture of the antenna array. . . . .	8
10	<i>E</i> -plane pattern of the antenna array. . . . .	10

## 1 Introduction

The electromagnetic code consortium (EMCC) is a joint organization sponsored by the US Air Force, the US Army, the US Navy, and the National Aeronautics and Space Administration (NASA) whose purpose is to advance computational electromagnetic (CEM) code development. To this end, the consortium collects and distributes data for benchmark CEM problems. Previously published EMCC benchmark data appears in [1],[2]. The new proposed problems include scattering targets with edges and corners and multi path effects. Some of the geometries are electrically large. Also, the first EMCC antenna benchmark is included.

## 2 NRL Problems

The first three problems are submitted to the EMCC by the Naval Research Laboratory (NRL). The geometries include a cube, a prism, and a pyramid. The measured data from NRL is collected in two passes with different levels of attenuation on the measurement equipment. This is done to improve the dynamic range of the data. However, due to data release problems at NRL, only the low attenuation data is available in most cases. This results in some clipping error near the peaks of the radar cross section (RCS) in a few of the plots in this report. In spite of this acknowledged error, it is believed that much of the available of the data is useful for code validation purposes. A follow up report is planned when the remainder of the data becomes available.

### 2.1 Cube

The cube is shown in Fig. 1. It is a high precision target, and it is a good canonical shape for code validation. Each side is one meter in length, and the edges are ground sharp. The RCS of the cube as a function of azimuth angle at  $0^\circ$  elevation for 0.43 GHz and 1.3 GHz is shown in Fig. 2. The error near the peak of the 1.3 GHz, VV-polarized result is caused by clipping in the measurements, as discussed in the introduction to Sec. 2. The computed results in Fig. 2 are generated with the Fast Illinois Solver Code (FISC). The 0.43 GHz results are generated using 2304 unknowns and 362 right hand sides in 17.6 minutes on a SUN Ultra-60 processor, and the 1.3 GHz results are generated using 18432 unknowns and 362 right hand sides in 4.84 hours on a single SUN Ultra-60 processor.

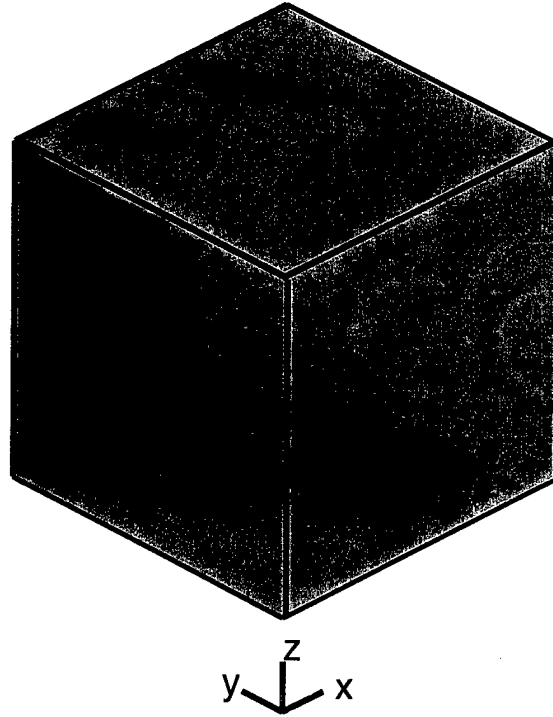
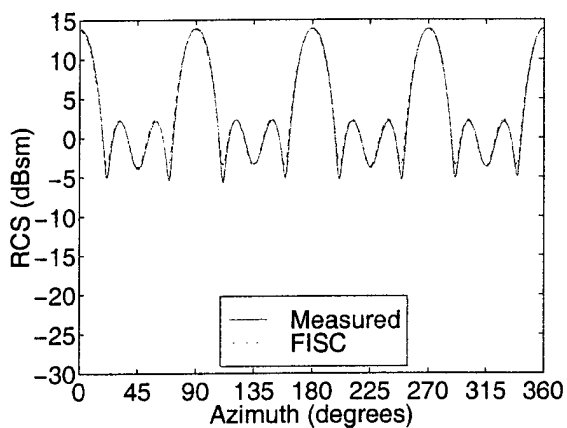

Figure 1: Picture of the cube.

## 2.2 Prism

The prism is shown in Fig. 3. The purpose of the prism is to capture traveling wave effects for three different wedge angles. The sides are 94.83 cm, 178.24 cm, and 240.13 cm in length, resulting in wedge angles of  $20^\circ$ ,  $40^\circ$ , and  $120^\circ$ , and the thickness is 30.48 cm. The edges are sharp. The RCS of the prism as a function of azimuth angle at  $10^\circ$  elevation for 0.43 GHz, 1.3 GHz, and 9.2 GHz is shown in Fig. 4. The error near the peaks of some of the plots is caused by clipping in the measurements as discussed in the introduction to Sec. 2. The computed results for 0.43 GHz and 1.3 GHz are generated by FISC, and the 9.2 GHz results are generated using the high frequency shooting and bouncing ray (SBR) code xpatch. The 0.43 GHz results use 1140 unknowns and 1442 right hand sides and require 49.6 minutes on a SUN Ultra-60 processor, and the 1.3 GHz results use 11904 unknowns, 1442 right hand sides, and 26.7 hours on a SUN Ultra-60 processor. The high frequency 9.2 GHz results are sampled every  $0.2^\circ$  and first order edge diffraction is included; these results are generated in 35.8 minutes on a SUN-Ultra-60 processor. Note that traveling wave effects are not included in the high frequency SBR approximation; thus, the computed results are lower than the measurements in regions of low RCS.



(a) 0.43 GHz, VV-polarized

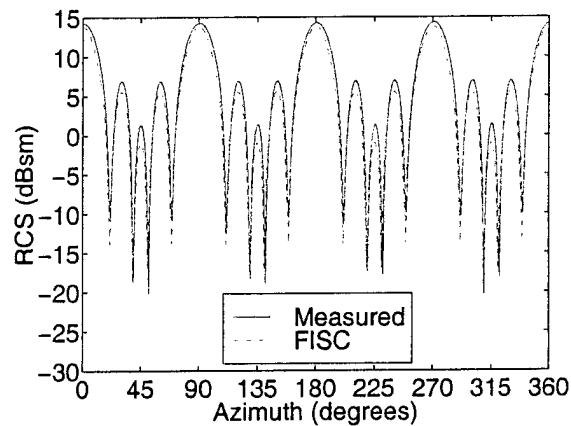

(b) 0.43 GHz, HH-polarized

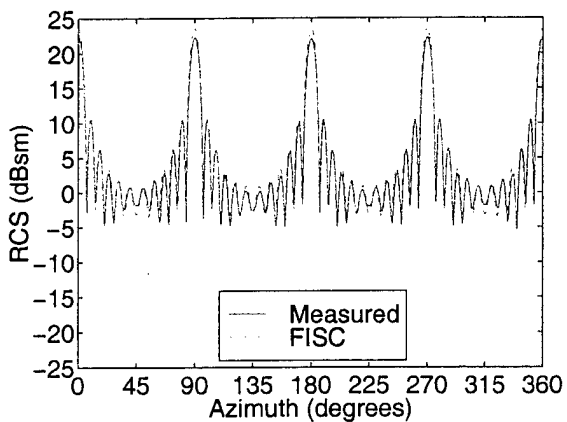

(c) 1.3 GHz, VV-polarized

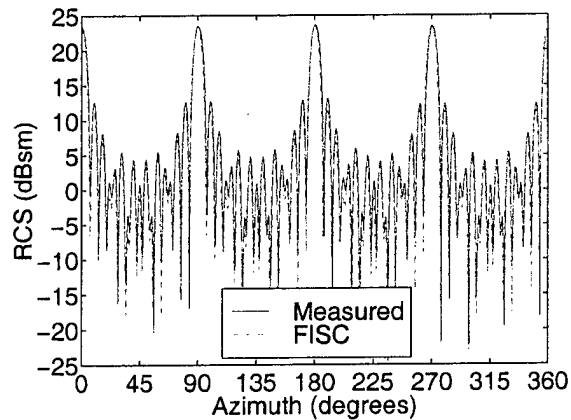

(d) 1.3 GHz, HH-polarized

Figure 2: RCS of the cube at  $0^\circ$  elevation for 0.43 GHz and 1.3 GHz. The error near the peak of the 1.3 GHz, VV-polarized result is caused by clipping in the measurements as discussed in the introduction to Sec. 2.

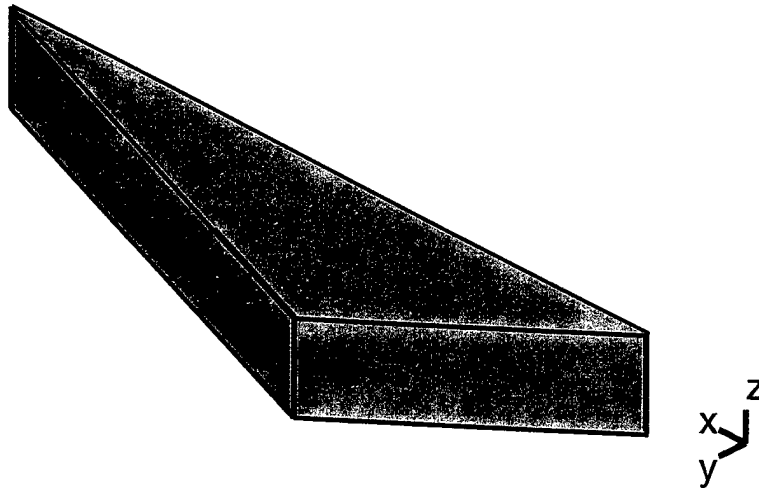

Figure 3: Picture of the prism.

### 2.3 Pyramid

The pyramid is shown in Fig. 5. Its base (surface in the  $x - y$  plane of Fig. 5) is a triangle with sides 32.41 cm long, and its height from the center of the base to the opposite vertex is 33.20 cm, resulting in side lengths of 38.10 cm from the corners of the base to the vertex opposite the base.

To create multi path results, the pyramid is measured at 9.2 GHz and  $16^\circ$  elevation on a metalized bounce plane. (The bounce plane corresponds with the  $x - y$  plane.) Unfortunately, the VV-polarized measured data for the pyramid has a very high noise floor, but the HH-polarized data is somewhat better. Measured results and computed results generated with the EMCC code AIM are shown in Fig. 6. The computed results used 53985 unknowns and 1442 right hand sides and required 78 hours on 11 SGI Origin 2000 processors. There is apparently some measurement error or error in construction of the target as evidence by the peak shift near  $120^\circ$  azimuth in both polarization plots in Fig. 6.

## 3 Trihedron

The trihedron is submitted to the EMCC from the National Ground Intelligence Center. The geometry with relevant dimensions is shown in Fig. 7. Electromagnetic scattering from this target includes multiple interactions, surface waves, and edge waves. The measured and computed (using FISC) RCS at  $10^\circ$  elevation,  $0^\circ - 90^\circ$  azimuth, and 10 GHz are shown in Fig. 8. The computed results used 619587 unknowns and 362 right hand sides and required 98 hours on 24 SGI Origin 2000 processors. Note that the thickness of the plates is not included in the geometry description available for generating computed results. Thus, the

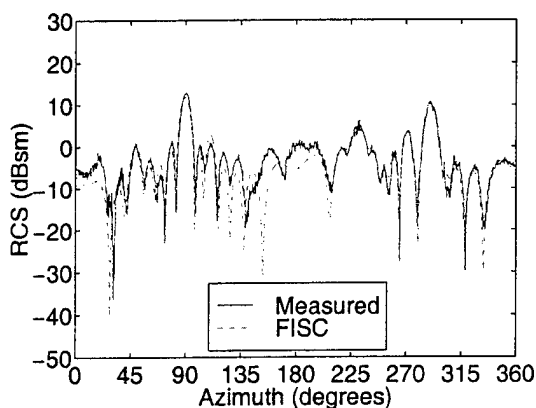

(a) 0.43 GHz, VV-polarized

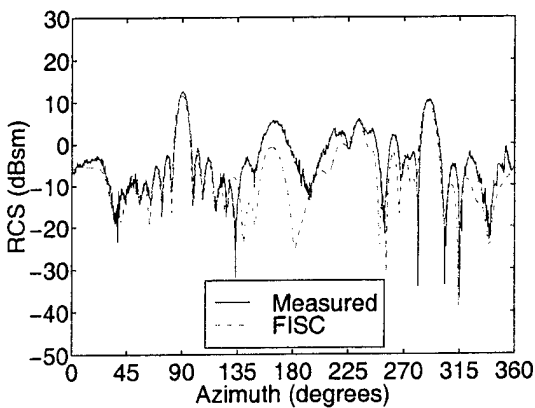

(b) 0.43 GHz, HH-polarized

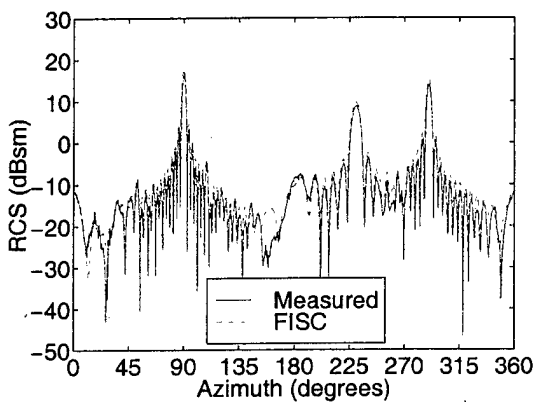

(c) 1.3 GHz, VV-polarized

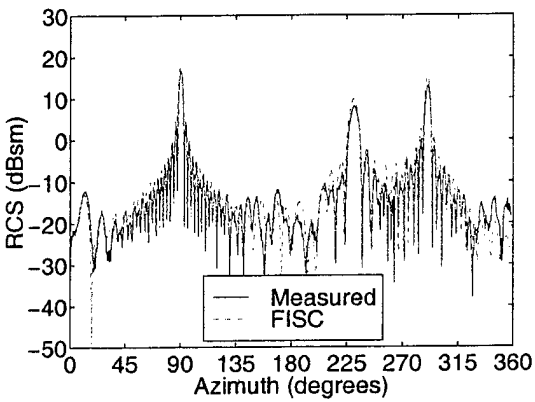

(d) 1.3 GHz, HH-polarized

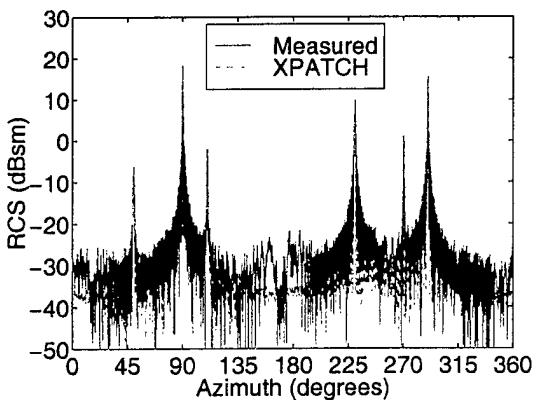

(e) 9.2 GHz, VV-polarized

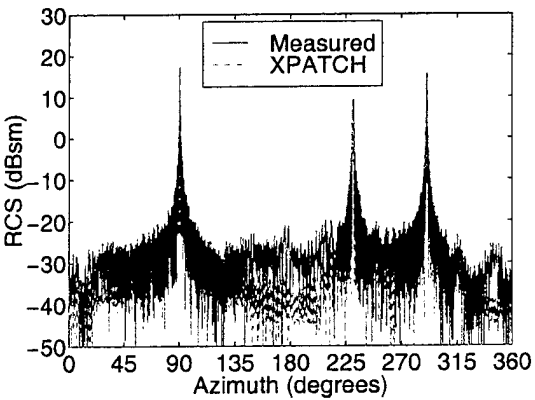

(f) 9.2 GHz, HH-polarized

Figure 4: RCS of the prism at 10° elevation for 0.43 GHz, 1.3 GHz, and 9.2 GHz. The error near the peaks of some of the plots is caused by clipping in the measurements as discussed in the introduction to Sec. 2.

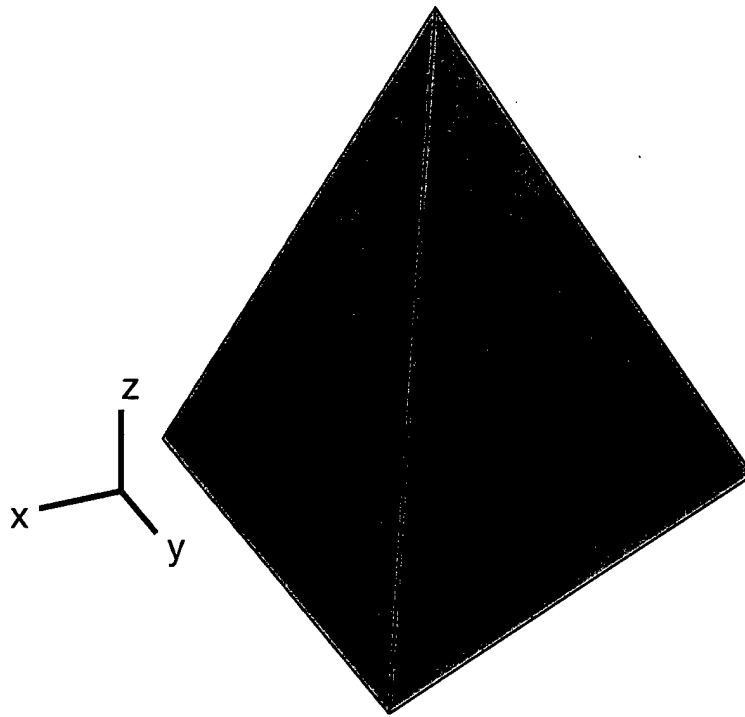

Figure 5: Picture of the pyramid.

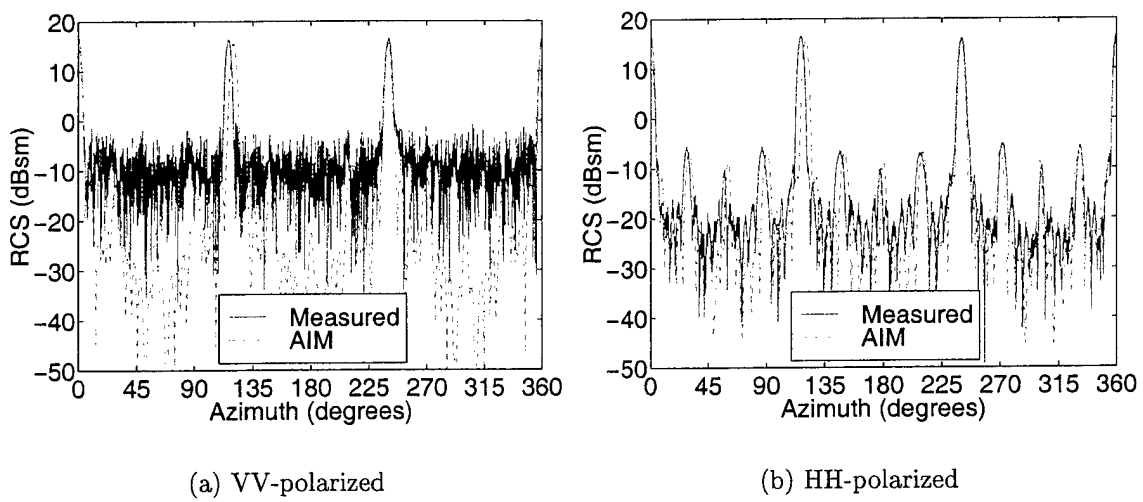

Figure 6: RCS of the pyramid on a metal bounce plane at 16° elevation and 9.2 GHz.

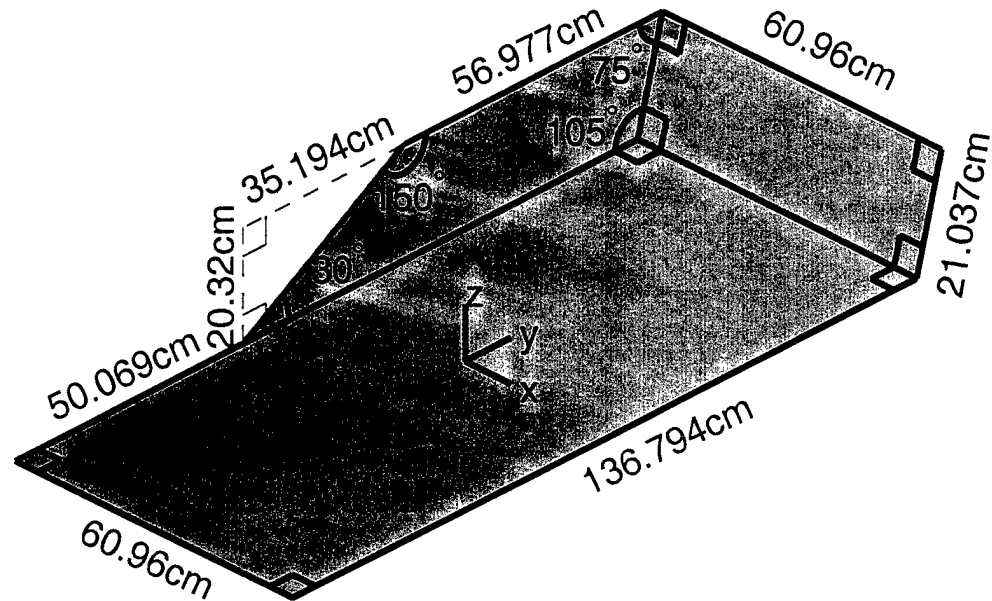

Figure 7: Picture of the trihedron with relevant dimensions. Note that the bottom plate is parallel to the  $x - y$  plane; the left plate is parallel to the  $y - z$  plane; the back plate is tilted  $15^\circ$  toward the  $y$  axis from parallel to the  $x - z$  plane.

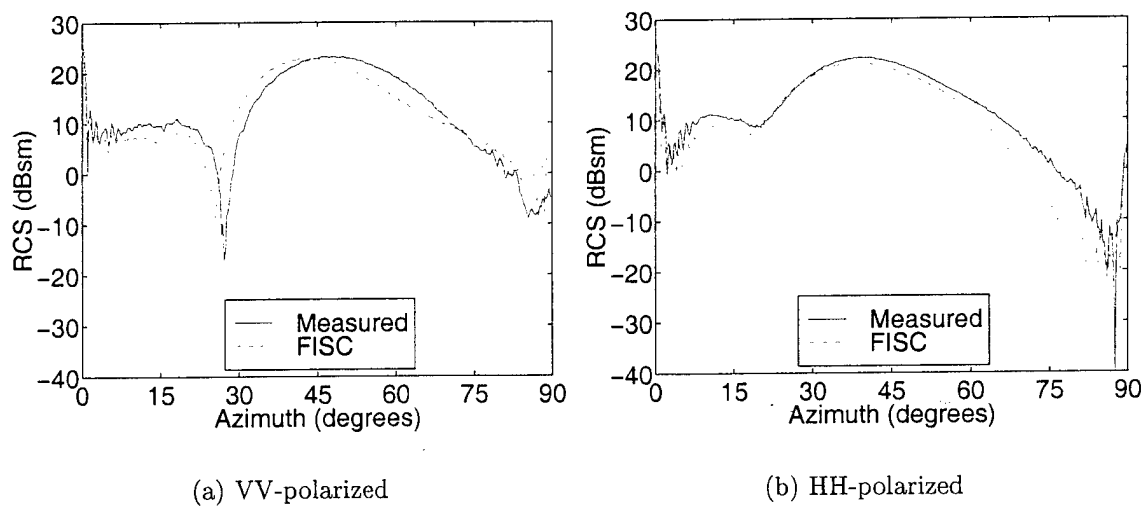

Figure 8: RCS of the trihedron versus azimuth  $10^\circ$  elevation and 10 GHz. The plates in the FISC computations are modeled as 0.3 cm thick.

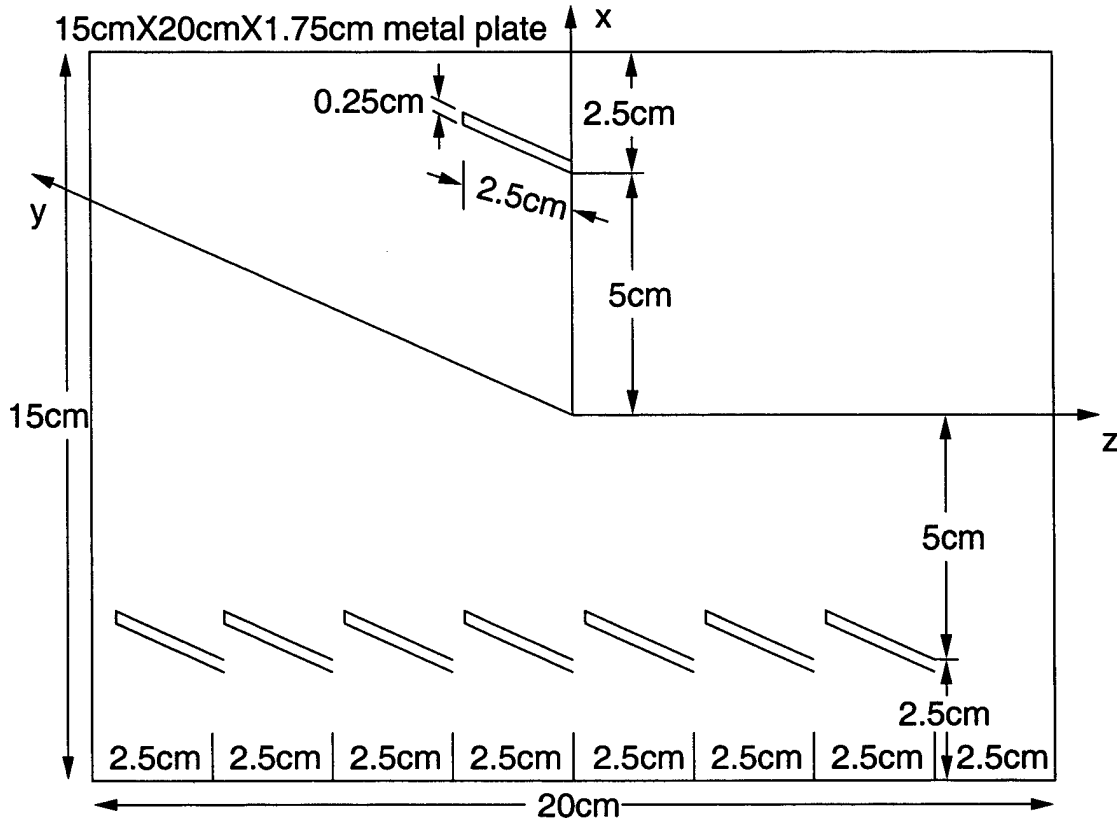

Figure 9: Picture of the antenna array with relevant dimensions. The thickness of the plate is 1.75 cm. The elements are modeled as infinitely thin. The element at top is driven; the others are passive.

plates are arbitrarily assigned a thickness of  $\lambda/10 = 0.3$  cm. This is a possible source of error in the computations.

## 4 Antenna Array

The final benchmark of this report involves the computation of the radiation pattern of an antenna array on a flat plate, which represents the first EMCC antenna benchmark. It is hoped that future benchmarks will include many more antenna problems, including near field problems such as the computation of the antenna input impedance.

The geometry of the antenna array is shown in Fig. 9. In the figure, the elements are modeled as infinitely thin, and the element shown at the top of the figure is driven; the other elements are passive.

The  $E$ -plane pattern of the antenna array is measured at 5 frequencies from 5.3 GHz to 5.7 GHz and shown in dB down from the maximum in Fig. 10. Two computed results are also shown in Fig. 10, one generated from the EMCC code AIM, and the other generated from

the TSAR finite-difference time-domain (FDTD) code. The AIM results took approximately 4.5 hours per frequency to run on a SUN Ultra-60 processor, and the FDTD results took approximately 14.2 hours for all 5 frequencies in a single run on a SUN Ultra-60 processor.

## 5 Conclusion

A cube, a prism, a pyramid, and a trihedron are added to the EMCC scattering benchmarks, and an antenna array on a metal plate represents the first EMCC antenna radiation benchmark. Measured data for each case is compared to computed data, and where possible, sources of error are identified. Although some problems are known to exist with the data, it is believed that this data is valuable to the computational electromagnetics community for code testing purposes. In the cases of the cube, prism, and pyramid, measured data improvements (see Sec. 2) are expected in the future, and a follow on report is planned.

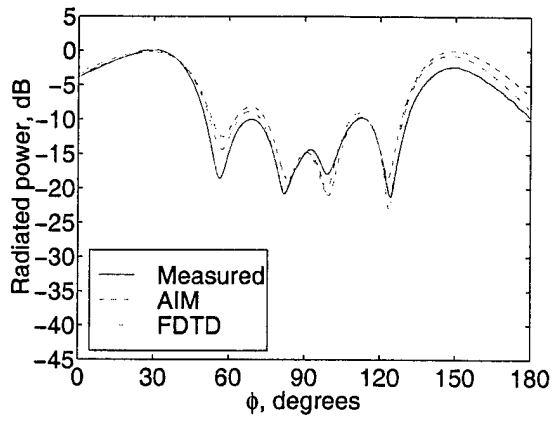

(a) 5.3 GHz

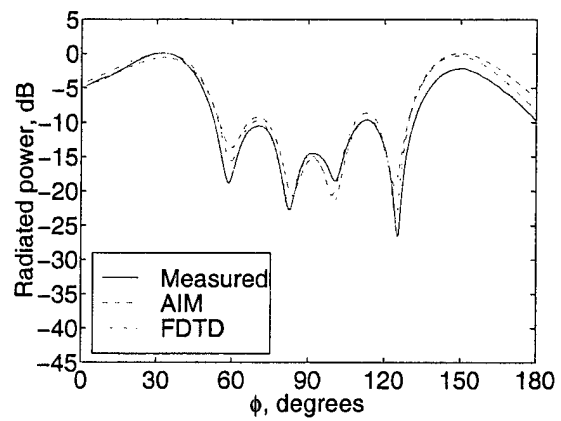

(b) 5.4 GHz

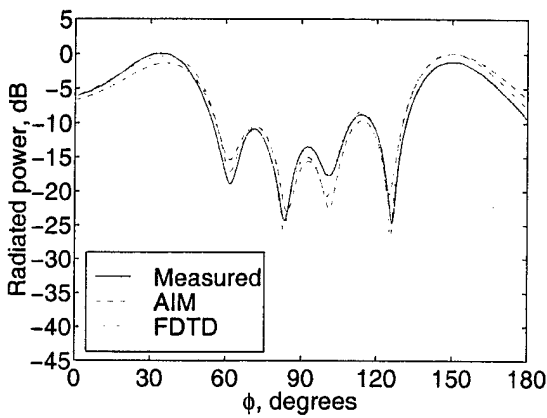

(c) 5.5 GHz

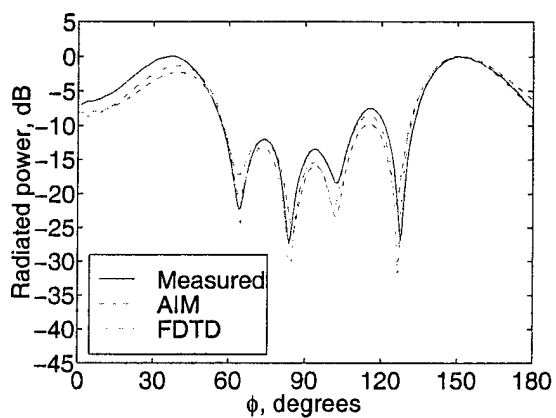

(d) 5.6 GHz

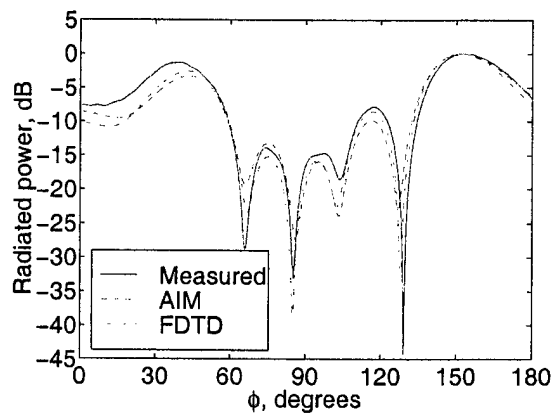

(e) 5.7 GHz

Figure 10: *E*-plane pattern of the antenna array in dB down from the maximum. The angle  $\phi$  is measured from the positive  $x$ -axis.

## References

- [1] A. C. Woo, H. T. G. Wang, M. J. Schuh, and M. L. Sanders, "Benchmark plate radar targets for the validation of computational electromagnetics programs," *IEEE Antennas Propagat. Mag.*, vol. 34, pp. 52-56, Dec. 1992.
- [2] A. C. Woo, H. T. G. Wang, M. J. Schuh, and M. L. Sanders, "Benchmark radar targets for the validation of computational electromagnetics programs," *IEEE Antennas Propagat. Mag.*, vol. 35, pp. 84-89, Feb. 1993.

## DISTRIBUTION LIST

DTIC/OCP 8725 John J. Kingman Rd, Suite 0944 Ft Belvoir, VA 22060-6218	1 cy
AFRL/VSIL Kirtland AFB, NM 87117-5776	2 cys
AFRL/VSIH Kirtland AFB, NM 87117-5776	1 cy
Official Record Copy AFRL/DEHE/Andrew Greenwood	8 cys