

IM-02/1

**MEASURING TIME-DEPENDENT PAVEMENT DEFLECTION
PROFILES UNDER DRIVE-BY CONDITIONS WITH A
PORTABLE SYSTEM**

Andres Peekna
Innovative Mechanics, Inc.
265 Coe Rd., Clarendon Hills, IL 60514-1029
Tel/fax: 630-887-9020
Email: innmech@worldnet.att.net

James L. Pickens
Pick Associates
305 Warren St., Vicksburg, MS 39180
Tel: 601-636-0455
Email: pickens@canufly.net

Jim W. Hall, Jr.
Eres Consultants
Division of Applied Research Associates
112 Monument Place
Vicksburg, MS 39180
Tel: 601-638-5401
Email: jhall@ara.com

February 2002

Final Technical Report for SBIR Phase I

This material was sponsored by and prepared for the Department of the Army, Corps of Engineers, under contract number DACA42-01-C-0035.

REPORT DOCUMENTATION PAGE

Form Approved
OMB NO. 0704-0188

Public Reporting burden for this collection of information is estimated to average 1 hour per response, including the time for reviewing instructions, searching existing data sources, gathering and maintaining the data needed, and completing and reviewing the collection of information. Send comment regarding this burden estimates or any other aspect of this collection of information, including suggestions for reducing this burden, to Washington Headquarters Services, Directorate for information Operations and Reports, 1215 Jefferson Davis Highway, Suite 1204, Arlington, VA 22202-4302, and to the Office of Management and Budget, Paperwork Reduction Project (0704-0188,) Washington, DC 20503.

1. AGENCY USE ONLY (Leave Blank)		2. REPORT DATE Feb 12, 2002	3. REPORT TYPE AND DATES COVERED Phase I Final Report for period 11 May 2001 to 11 December 2001
4. TITLE AND SUBTITLE Measuring Time-Dependent Pavement Deflection Profiles Under Drive-by Conditions with a Portable System		5. FUNDING NUMBERS Contract No. DACA42-01-C0035	
6. AUTHOR(S) Andres Peekna, James L. Pickens, Jim W. Hall, Jr.			
7. PERFORMING ORGANIZATION NAME(S) AND ADDRESS(ES) Innovative Mechanics, Inc., 265 Coe Road, Clarendon Hills, IL, 60514-1029 Pick Associates, 305 Warren St., Vicksburg, MS 39180 ERES Consultants, Div'n of Applied Research Associates, 112 Monument place, Vicksburg, MS 39180		8. PERFORMING ORGANIZATION REPORT NUMBER IM-02/1	
9. SPONSORING / MONITORING AGENCY NAME(S) AND ADDRESS(ES) SPONSORING: Dept of the Army, Corps of Engineers Vicksburg Consolidated Contracting, 4155 Clay St., Vicksburg, MS 39183-3435 MONITORING: Dept of the Army, USACE Engineering Research & Development Center, 3909 Halls Ferry Rd., Vicksburg, MS 39180-6199		10. SPONSORING / MONITORING AGENCY REPORT NUMBER	
11. SUPPLEMENTARY NOTES			
12 a. DISTRIBUTION / AVAILABILITY STATEMENT Approved for public release; distribution unlimited.		12 b. DISTRIBUTION CODE	
13. ABSTRACT (Maximum 200 words) Measuring pavement deflections on secondary roads permits assessment of their performance upon passage of an Army convoy. On secondary roads traffic volume is low enough to permit drive-by conditions. The system was designed accordingly. For sensing pavement deflections, linear variable differential transformer (LVDT) sensors were chosen. The investigation showed that in order to credibly extrapolate from sensors away from the tires to deflection underneath the tires, a laterally separated pair of sensors at each longitudinal location would be necessary. The investigation also turned up options and trade-offs regarding different methods for end-supports of the lightweight aluminum beam which would support the sensor array. Sideways-looking ultrasonic sensors for detecting tire positions both laterally and longitudinally, independently of the LVDT's, were also selected and evaluated. Overall design philosophy was not to try to zero in on the optimum right away, but to permit reasonably maximum latitude for field experimentation.			
14. SUBJECT TERMS SBIR Report Drive-by conditions Pavement load capacity Pavement deflections Asphalt concrete Army convoys Deflection basin Secondary roads			15. NUMBER OF PAGES 46
			16. PRICE CODE
17. SECURITY CLASSIFICATION OR REPORT UNCLASSIFIED	18. SECURITY CLASSIFICATION ON THIS PAGE UNCLASSIFIED	19. SECURITY CLASSIFICATION OF ABSTRACT UNCLASSIFIED	20. LIMITATION OF ABSTRACT UL

NSN 7540-01-280-5500

Standard Form 298 (Rev.2-89)
Prescribed by ANSI Std. Z39-18
298-102

1. INTRODUCTION

The approach we have chosen is tailored to the following requirements.

- Primary application area would be secondary roads (not the equivalent of Interstates or Autobahns).
- The pavement would be asphalt-concrete, in almost all cases.
- The deflection data can be obtained under drive-by conditions at slow speeds, comparable to parking the vehicle.
- The secondary roads to be tested will not normally carry sufficient traffic to preclude having pylons and flagmen block traffic in either or both directions for setup/test duration.
- Primary vehicles of interest would involve groups of two tandem axles, such as the medium-weight tactical vehicle M1083, and the M977 10-ton HEMTT, although higher number of tandem axles can also be accommodated.
- The data obtained would be the best quality, at reasonable cost in setup time, processing, and hardware.

Let us state some of our conclusions first. One variant of the approach chosen is shown in Figure 1. The sensor support beam has arrays of linear variable differential transformer (LVDT) sensors in contact with the road measuring downward deflection. These are arranged in pairs at each longitudinal location, as a pair is necessary to fit a two-parameter curve which can credibly extrapolate to deflection under the tires.

The lateral position of the vehicle wheels are recorded by an array of ultrasonic ranging sensors aimed horizontally, toward the vehicle, from on top of the support beam. These ultrasonic sensors will also record (independently of the LVDT's) the longitudinal position of the vehicle at various times.

The support beam has a bolted joint at its middle, enabling transport in a relatively small vehicle, such as a HMMWV.

End supports shown in Figure 1 are simple end supports. They are L-shaped, with a sandbag shown on the horizontal leg of each L, to enhance stability. A disadvantage of simple end supports is that they themselves will deflect downward whenever there is a vehicle axle next to them. This limits most useful primary data to times when the axle or axle group of interest is pretty well centered on the extent of the beam longitudinally (as in Figure 1).

The option of end supports cantilevered out from the side is shown schematically in Figure 2. Supporting cantilevers from the roadside was abandoned due to highly variable conditions such as presence or absence of a ditch, etc. But on a two-lane road, it appears perfectly feasible to support the cantilevers from one driving lane, while leaving the other free for traffic, during setups. The only time both lanes would be blocked would be during drive-by data-taking, which would be significantly less than set-up time. The vehicle may be driven in either direction.

The cantilevered end supports (Figure 2) have the advantage that they are not subject to the downward movements of the simple end supports (Figure 1) when an axle is next to a beam end. Thus, they could also handle vehicles with closely spaced axle groups involving more than two tandem axles. On the other hand, at least with a full-length beam, the cantilevered end supports will bring in a setup time higher than what can be achieved with simple supports. But as the cantilevered end supports are not subject to motion, they could also be used with a much shorter beam, as for example half length, with correspondingly fewer sensors. Here, the tradeoffs in setup time become less clear. Only experimentation and experience can decide which is best under what conditions.

The next section, Section 2, will cover a survey of sensor technologies, both for sensing deflection and vehicle position, laterally and longitudinally. This will help clarify why we chose the approach pursued. We will return to the proposed design in Section 3.

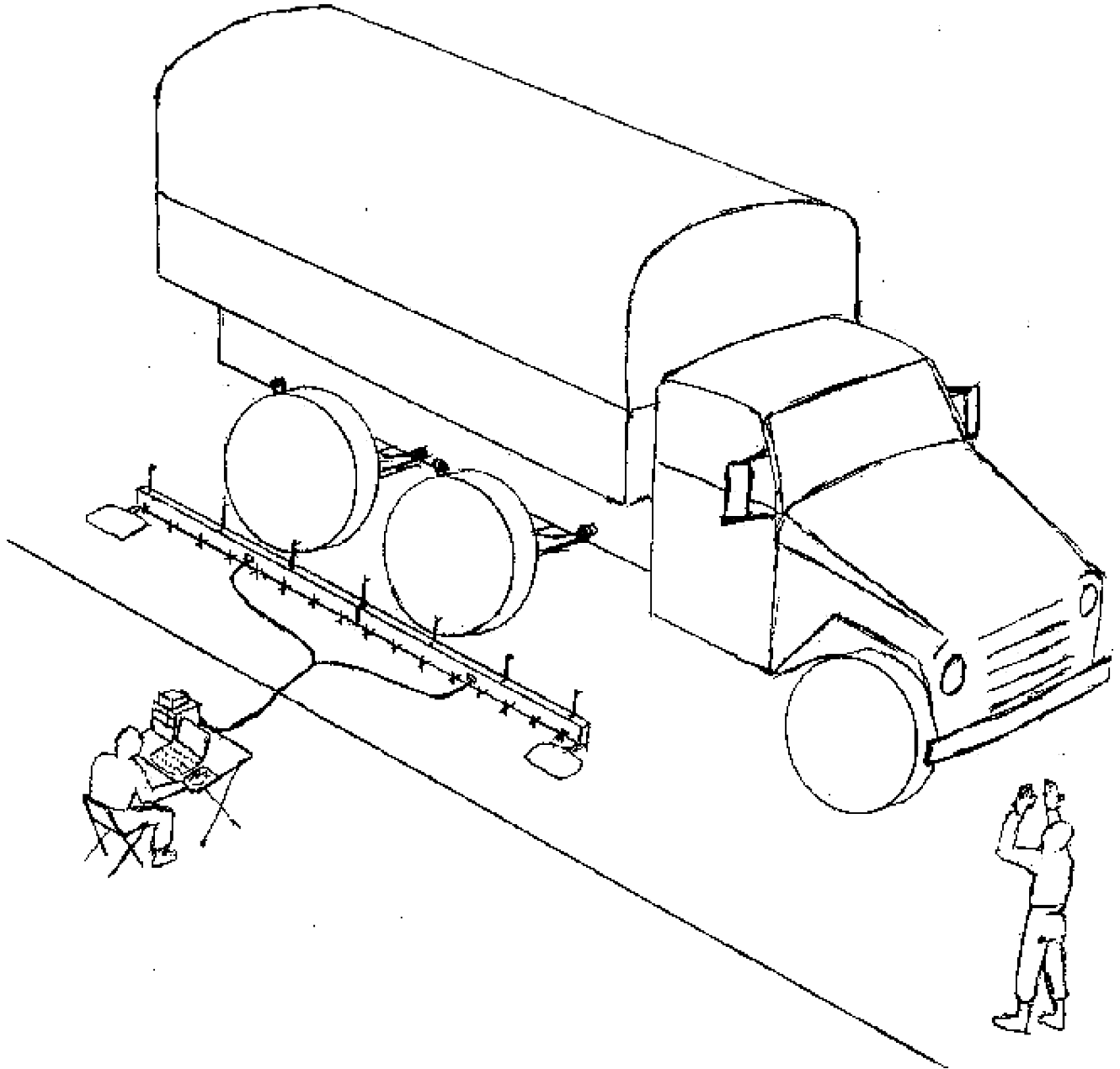

Figure 1. Beam with sensor array, beside vehicle. As vehicle drives by, guide hand-signals distance from outside of tires to beam. Actual lateral (and longitudinal) position of tires would be recorded by ultrasonic sensors aimed horizontally, toward the vehicle. Simple end supports are shown.

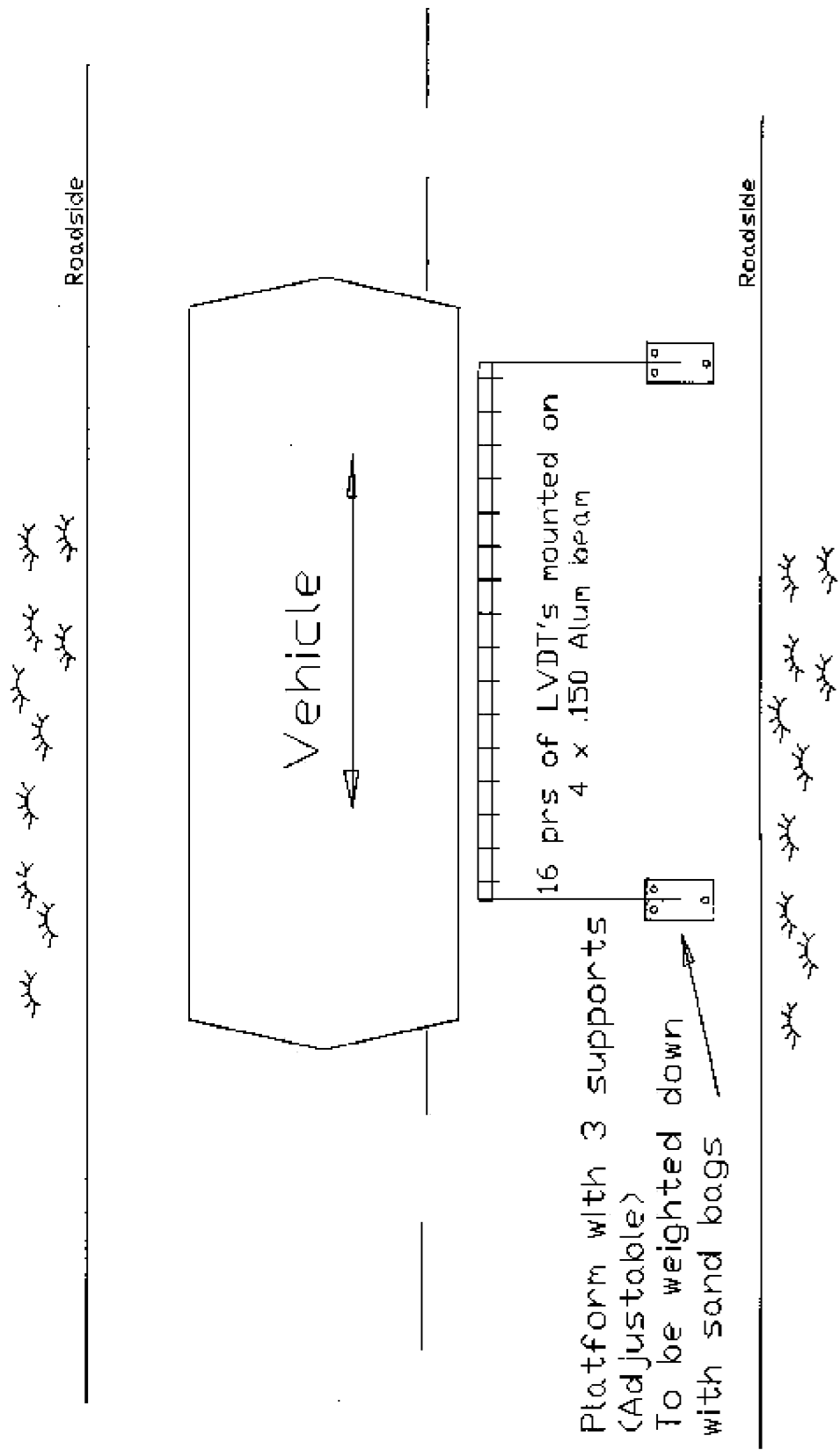

Figure 2. Top view (schematic) of beam with sensor array, beside vehicle, showing the option of cantilever supports. Sandbags used to weight down the platforms are not shown.

2. SURVEY OF SENSOR TECHNOLOGIES

2.1. Candidate Sensors for Deflection

The measurement system required here is a classic example of the trade-offs and compromises needed for the design of measurement systems. These trade-offs include the eternal conflict between range vs. resolution, ease of operation, set-up time, portability, ruggedness, accuracy, stability, and cost. All of these factors have weight in the selection of the various elements of a system design. The system must be sensitive enough to be able to measure displacements of 0.001 inch accurately, and be able to resolve differences of 0.0001 inch.

2.1.1. Linear Variable Differential Transformers (LVDT,s)

These were considered front-runners in the proposal stage, and subsequent investigation has only confirmed that. Since drive-by conditions permit using contacting sensors, it appears logical to do so. The LVDT, which has been used as a displacement measurement device for 50 years, is a proven gage. The only significant improvements in the gage over the years have been in range and ruggedness. The electronic signal conditioning equipment has changed, improving the signal-to-noise ratios, but the gage has remained basically the same. The LVDT is not a strain gage based instrument, subject to changes due to temperature or cable length. It consists of a magnetically coupled transformer with a variable reluctance, depending on the physical position of a permanent magnet armature. The AC voltage excitation is applied to the primary of the transformer, and coupled to the double secondary windings. The amplitude of the secondary voltage is proportional to the position of the armature, (amount of change in reluctance). The electronic signal conditioner changes this to a DC voltage, directly proportional to the input excitation voltage and position of the magnet armature in the gage. Both Jim Pickens and Andres Peekna (Principal Investigator) have experience using LVDT's in the past, with excellent results.

In the survey, both Andres Peekna and Jim Pickens independently reached the conclusion that RDP Electrosense (Pottstown PA) appears to be an industry leader in manufacturing LVDT sensors. Attendance by Andres Peekna at the Sensors Expo, Rosemont, IL in June 2001 gave an opportunity to interact directly with various vendors. Among vendors of LVDT's RDP Electrosense appeared to be the most prominent at this trade show. Their personnel were also very helpful; among other things they referred us to a source of desirable mushroom-shaped contact tips compatible with their sensors (Carbide Probes, Inc., Dayton, OH). (Such tips are shown in Figure 4, p. 11.) These tips prevent transducer damage from side-loading the probe and allow consistent and stable measurements of uneven surfaces.

For this project, requiring displacements of 0.01 in. to 0.03 in. to be recorded with < 0.0001 inch resolution, the Model D5/200AG LVDT was chosen. This gage, a +/- 0.20 in. gage with theoretically infinite resolution, has an output of +/- 10 volts full scale, and requires a signal conditioning amplifier with a gain of only ten to allow resolutions of less than 0.1 mil. (actually 0.06 mil) The low gain in the amplifier also improves the signal-to-noise ratio, increasing resolution even further. The probe is spring-return, with low (4.6 oz) maximum spring force. This transducer was selected for this project because of the trade-off between range/resolution, accuracy, ease of operation, setup time, and cost.

The signal conditioning equipment for the LVDT's is available from RDP. The Model 621 Carrier amplifier is a 2-channel module, supplying the 5 kHz carrier excitation voltage and a demodulator, with a variable DC voltage output directly proportional to displacement. RDP also can supply a difference module to measure the difference between any two outputs. The electronic cages that house these modules also contain analog-to-digital converters to provide a digital data string to the computer for recording.

LVDT's made by Schaevitz Sensors Division of Measurement Specialties (Hampton VA) also have an excellent reputation. Most of their offerings are heavy and bulky, which detracts from portability. Their MHR Series (Miniature LVDT) is an exception. However, in this series the core is loose, and not held by a spring return device. This would make setup very awkward. Nor does their core permit mounting of the mushroom-shaped contact tips made by Carbide Probes. Similar comments apply to their Sub-Miniature LVDT series.

2.1.2. *Optical Sensors Operating by Laser-Triangulation.*

Such are widely used high-accuracy non-contact sensors in much of industry. Most are designed for surfaces within a narrow range of reflectivities, as is common on most production lines. Micro Epsilon (Ortenburg, Germany) offers such sensors for approximately \$2200 apiece. Price of suitable RDP Electrosense LVDT sensors is approximately \$600 per channel with signal conditioning, for comparison.

Moreover, experience of the Principal Investigator in another current project (a subcontract from ERES Consultants, Applied Research Associates) involving measuring deflections at highway speeds brought out the fact that laser-triangulation sensors to be used for *road* sensing need special provisions, such as closed-loop control of laser power to accommodate widely varying reflectivities typically found on road surfaces. Currently, the industry leader in laser-triangulation *road* sensors is LMI-Selcom, Southfield MI. (Their road sensors were developed and are still being manufactured in Sweden.) The increased capability of handling road surfaces does not come without a price; in quantities of 5, LMI-Selcom sensors suitable for road-sensing would be approximately \$7000 apiece.

An estimate of accuracy of resolution under conditions that the sensor would be looking at the *same* spot on the road at all times, as under drive-by conditions, was given by a representative of LMI-Selcom as $0.2(10^{-3})$ inch. This is on the verge of being competitive in accuracy, but not in cost.

The reflectivity requirements for road-sensing could be circumvented in this application by using suitable targets below each sensor. Such an approach still would cost more than the LVDT approach, and would introduce additional uncertainties.

Precautions which have to be taken against eye hazard are another disadvantage of laser-based sensors. While the beam cannot burn skin and diffuse reflection from the spot on the road will not harm an eye, a *specular* reflection, such as can occur off a shiny hand-tool, is equivalent to looking into the beam directly, and has to be avoided.

2.1.3. *Optical Sensors, Such as Operate by Measuring Intensity of Reflected Light*

These are lower in cost than optical sensors operating by laser-triangulation, though not as low as LVDT's. Philtec (Annapolis, MD) offers "reflectance compensated" sensors, which are claimed to be distance dependent but blind to target reflectance variations. After discussions regarding problems in road-sensing due to variable reflectance even with laser-triangulation sensors, with several parties, this approach was deemed not worthy of further pursuit. An additional reason: cost \$1750 per channel vs. \$600 per channel with LVDT's.

2.1.4. *Scanning Laser, Phoenix Scientific, San Diego, CA*

This does not use spot-sensors; instead it uses a scanning laser which measures distances using phase differences in modulation. Recently, it had significant successes in measuring road lateral profiles, which however call for accuracy of the order of 10^{-2} inch instead of the 10^{-3} to 10^{-4} inch desired here.

With the scanning laser scanning perpendicular to the vehicle path it would also permit recording of the lateral curve in pavement deflection immediately before or after any tire. Nevertheless, the challenges in extrapolating to deflection underneath the tires would remain.

Tests of accuracy sponsored by Applied Research Associates involving small steps in an otherwise flat surface yielded ability to resolve roughly ± 0.002 inch. LVDT type sensors can deliver an order of magnitude better, at much lower cost. Cost of a scanning laser would be of the order of \$100,000, whereas it would be approximately \$19,000 for the array of RDP LVDT sensors, including signal conditioning proposed.

With a scanning laser, any reflection from a specific spot would be of very short duration, so the eye hazard would not be as significant as with a fixed beam.

2.1.5. *Infrared Sensors*

Such are made by K.J. Law Engineers, Inc. (Novi, MI) and are used in road lateral profiling. Their resolution is 0.025 mm (0.001 inch) under static conditions and 0.25 mm (0.010 inch) under dynamic conditions, not adequate for deflection-measuring purposes in this application.

2.1.6. *Ultrasonic Sensors*

These are known not to have the resolution desired for measuring deflection (of the order of 10^{-4} inch, 0.0025 mm). Nevertheless, they perform adequately when measuring to the order of ± 1 mm, which makes them useful in sensing the positions of the tires (and therefore also the axles) as the vehicle drives by.

2.2. **Candidate Sensors for Vehicle Lateral and Longitudinal Position**

2.2.1. *Ultrasonic Sensors*

An array of these, aimed toward the vehicle wheels, was considered the front-runner in the proposal stage. They are known to be low in cost, as they are used for auto-focusing even inexpensive cameras, while not introducing any hazard to the operating personnel. They operate by emitting a high-frequency burst and measuring the time required for the echo to return.

The survey resulted in proposing the System RPS-8000A-12, Migatron Corp., Woodstock IL. This is an 8-channel system, which becomes a 7-channel system when one channel is dedicated to air-temperature compensation (recommended here). With ultrasonic sensors, crosstalk from one channel to another can be a problem. In this system, it has been engineered out by multiplexing. The system also has many other attractive features. The system has a minimum range and a maximum range. Above the maximum range, the signal becomes a constant, no target level. We chose the minimum range to be 4 inches (closer than that would risk the tires hitting the support beam) and the maximum range 12 inches (if the drive-by is further away, too much of the lateral extent of the deflection basin would be lost). The emitted ultrasonic beam is reasonably well collimated, fanning out to approximately 3 inch width at 10 inch distance from the sensor.

Migatron Corporation has carried ultrasonic sensor development beyond simple requirements such as in cameras. Their products are widely used for position detection on production lines in industry. The cost of their RPS-8000A-12 system is not unreasonable, approximately \$3000, or approximately \$430 per channel including signal conditioning. Attempts to duplicate their engineering would not be cost effective.

Migatron Corporation also furnished us a loaner unit of the RPS-8000A-12 (“try before you buy”). As this involved no out-of-pocket expense on our part, we decided to advance evaluation of these sensors into Phase I, instead of the Phase I Option as originally proposed. This evaluation was carried out in Vicksburg, MS and included a demonstration at the U.S. Army Engineer Research and Development Center (ERDC). The results are described in Section 4. For now, suffice to say that under test conditions the sensors met or exceeded their spec’s, and also proved capable of detecting the longitudinal positions of individual wheels.

2.2.2. *Optical Sensors Operating by Laser-Triangulation*

Besides significantly higher cost (reviewed in Section 2.1.2), safety problems due to eye-hazard would be exacerbated here, as the beams would be aimed not downward, but horizontally. Again, a *specular* reflection, such as can occur off a shiny hand-tool, is equivalent to looking into the beam directly, and has to be avoided.

A variant for sensing longitudinal position of the vehicle would be to use a long-range laser ranging sensor, aimed longitudinally at a target on the vehicle. In addition to the eye hazard mentioned above, this would bring in human-error type uncertainties as to distances between part of vehicle targeted and its axles. Such errors are eliminated when sensing the positions of the wheels/tires directly, as with ultrasonic sensors.

3. PROPOSED DESIGN

3.1. General Description

The longitudinal layout of the sensor support beam is shown in Figure 3. The support beam has a bolted joint at its middle. Beam half A is toward the left also in Figure 1 and in Figure 2. The lateral layout is shown in Figure 4, which is a cross section of beam half A, viewing toward the outer end. Thus parts of a simple end support are also visible in Figure 4. The sharp-tipped contact point of the end support near the vehicle path is partly hidden behind the contact tip for the LVDT sensor close to the vehicle path in Figure 4. The support beam would be Aluminum Association 4 x 0.150, weldable alloy 6061-T6.

The LVDT sensors are arranged in pairs at each one-foot-interval longitudinal location in order to make possible extrapolating from the deflections measured to deflections under the tires (which are inaccessible given a noninvasive system). This would be accomplished not by guesswork but by fitting a two-parameter curve. The procedure is subject to the assumption that the lateral shape of deflection basins are sufficiently similar geometrically such that they can be characterized by a parameter relating to maximum deflection, plus a parameter relating to lateral extent. Clearly, there are instances where such an assumption is violated, such as when comparing lateral shapes of deflection basins from single versus dual tires. But in the end, all this means is that we may need to know geometric lateral shapes of deflection basins for more than one tire configuration. This will be discussed in greater detail in Section 3.4.

Each of the two eight-foot beams (bolted together) would contain a connector box, with two multi-pin connectors. The LVDT's and the ultrasonic sensors would connect to these boxes on the beam. Two multi-conductor trunk cables, 15-20 feet long, with mating connectors, would send the gage outputs to an equipment rack, shown in Figure 5. This rack weighs about 50 lb., and contains the LVDT and ultrasonic signal conditioners and a specially built switch/monitor panel that allows the operator to observe the individual analog outputs of the gages before they are sent to the computer. The rack would be located on a folding table such as shown in Figure 1. Since noise does not show on a digital meter, this analog output must be viewed with an oscilloscope before it is digitized. This is a vital feature especially during the "debugging" process, or any field maintenance or even checkout process. The whole electronic package would be powered with a single 12v car battery.

The outputs of all the gages would be sent to a laptop computer, loaded with the appropriate data acquisition software. (National Semiconductor LABTECH or equiv.) This proposed system uses a single RS-232 serial data cable computer input. The entire analog data system, consisting of 32 LVDT outputs, 16 LVDT differential outputs, eight ultrasonic sensor outputs, (seven data and one for temperature compensation) is multiplexed and converted to a serial string by A to D converters in the signal conditioning box. The only cable hookups required by the operator are two sets of trunk cables from the beam to the rack, the RS-232 cable to the computer, and the 12v car battery to the rack. The laptop computer can be configured as an oscilloscope with the LABTECH or LABVIEW data acquisition software. Once the quality of the analog signals is verified, the test can begin and the computer can be told to start recording.

Detailed shop drawings of the support beam and gage mount hardware are given in the Appendix. Each beam half (with sensors, mounts, cables and connector box) would weigh approximately 25 lbs. Once bolted together, the total weight of the support beam (as above) would be approximately 50 lbs. With the simple supports at the ends attached, the total weight would become approximately 54 lbs.

The weight of a cantilever end-support is estimated at roughly 25 lbs (each). With a full-length (16-foot) beam, estimated minimum weight of sandbags required to solidly anchor cantilevered end supports total roughly 125 lbs at each support, and a 200-lb weight at each support is recommended. The sandbags come in lighter individual units. Thus, no component of this system imposes strength requirements beyond Army standards for both male and female personnel.

We are essentially ready to build a prototype system. The only parts not yet designed in detail are the cantilevered end supports and the mounts for tilt sensors at the ends.

Proposed beam with gages

16 prs of LVDT's
RTP Mod # 05/200AG
Mounted 1 ft apart

7 Migaatron TSR-3
Ultrasonic Transducers
2.5 Feet Apart

Simple end supports shown
End supports cantilevered
from the side can also be used

All Dimensions in feet unless otherwise indicated

Center of beam is between end plates
End plates bolted with high-strength
bolts and locator pins

Temperature compensation
Ultrasonic target at 8 in.

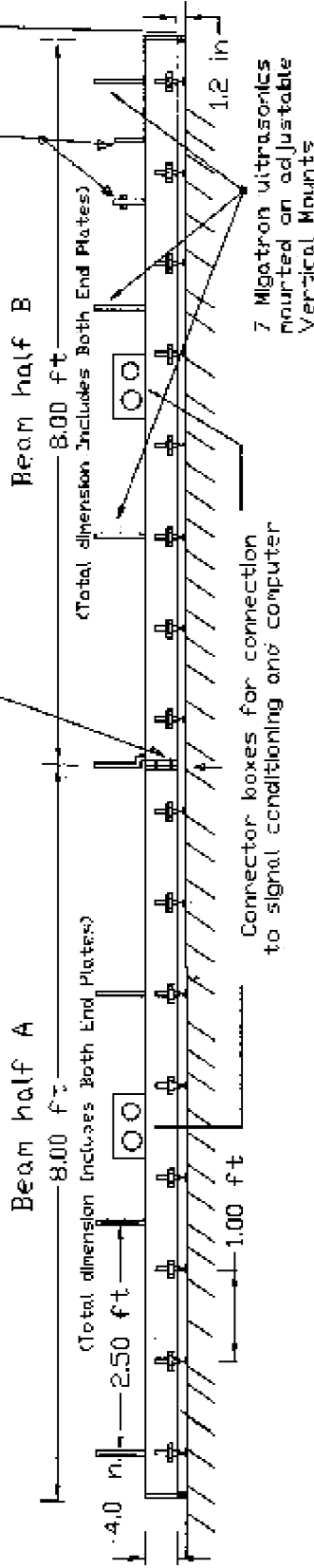

Bottom of beam is 1.2 in. above a straight-profile surface
LVDT's will be installed so that they are at the center
of their linear measuring range. Here they are shown
also at the centers of their mechanical adjustment range.

Figure 3. Longitudinal layout of sensor locations along support beam.
View is from the edge of the road, toward the vehicle

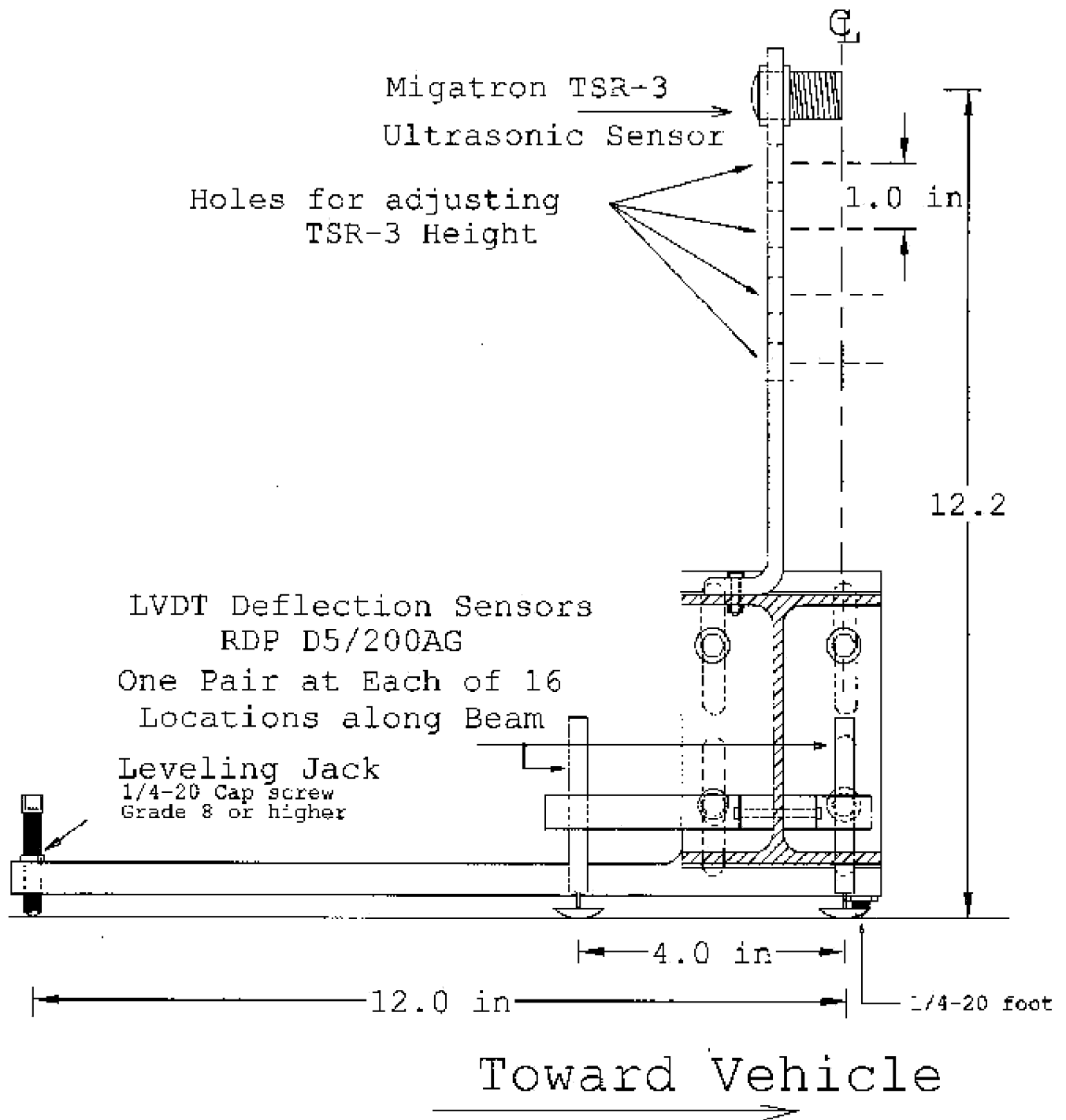

Figure 4. Cross section of beam half A, viewing toward outer end. Some details are omitted for clarity.

Proposed signal conditioning system

- 3 MOD 604 Enclosures
- 32 Channel LVDT, 16 Channel Computational Amplifier for LVDT
- 8 Channel DC-DC (differential)
- 4 DC Amps for conditioning
- Migatron outputs for digitizing
- 3 DC/DC Power Supplies
- 28 sets of DIN connectors
- 2 Expansion cards for serial interface
- Migatron RP8000A signal box containing 8 channels Sensors
- 34 RDP mod D5/200AG LVDT's (incl. 2 spares) @\$240 ea
- 10 Migatron TSR-3 ultrasonics @ #140 ea
- RDP Hardware Cost \$appr. \$19K
- Migatron Hardware cost approx. \$3K
- Carbide tips \$3.2K
- Other Hardware approx. 4K

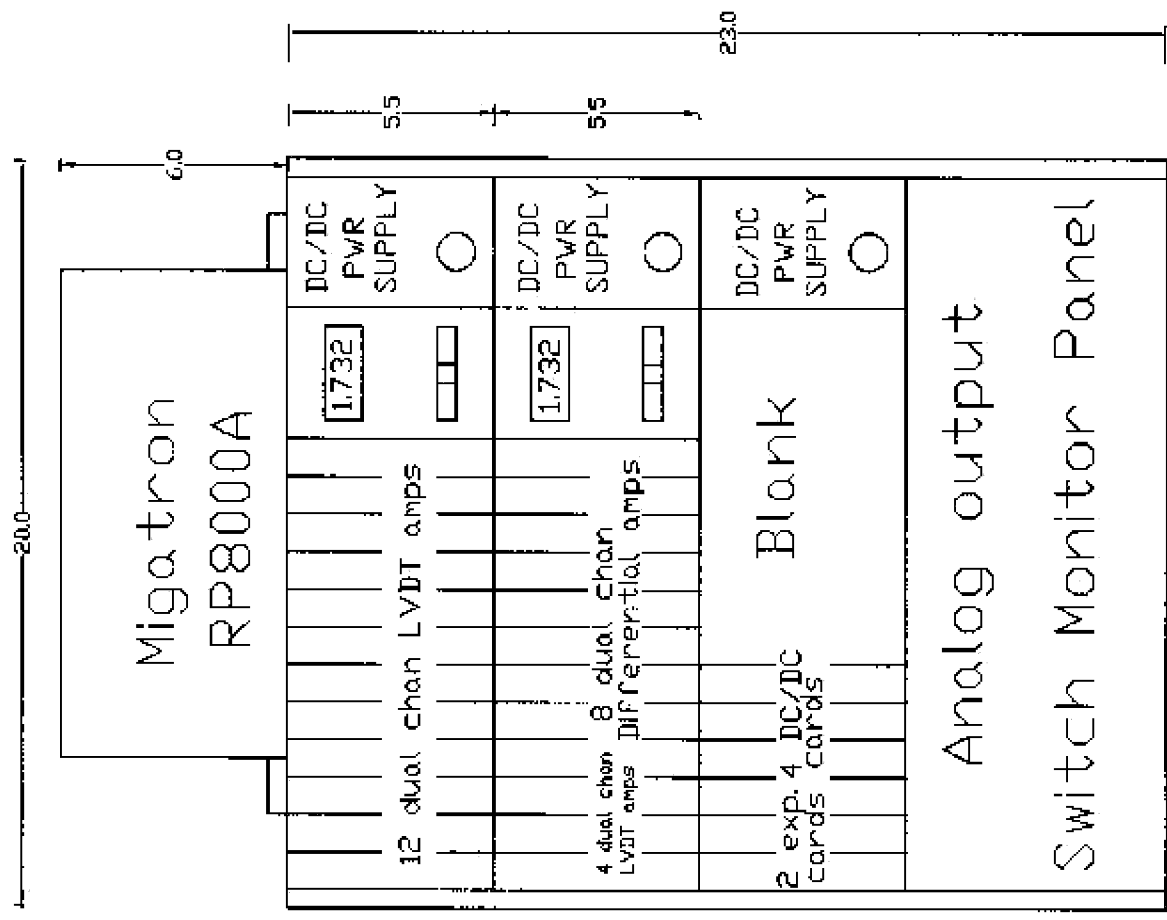

Figure 5. Spatial layout of signal-conditioning system. Dimensions are in inches.

3.2. Design for Prototype Versatility: Possible Experiments, Mechanical Adjustment Ranges, Setup Procedures.

3.2.1. Possible experiments

Since at the moment we are designing a prototype and not final product, we have followed the philosophy of maximizing leeway for experimentation rather than minimizing unit cost right away. For example, we do not claim to know at this point whether we can get away with less than 16 pairs of LVDT sensors spaced one foot apart longitudinally. Current conservative estimates (Section 3.3; Extents of Deflection Basins) suggest that such will suffice with two tandem axles, even with simple end-supports for the beam. To find out whether we can actually get away with fewer sensors, it is simple to disconnect some, and take data accordingly. (Much easier than modifying the prototype to accommodate additional sensors.)

The reason why not as many ultrasonic sensors are needed for sensing tire positions as the LVDT deflection-sensor pairs relates to the assumption that the drive-by speed would be reasonably (though not exactly) constant. (Position versus time nearly linear.) Thus, linear interpolation becomes reasonable for vehicle position purposes. By contrast, the deflection basin has a more complicated shape.

When using cantilevered end-supports (Figure 2), the beam no longer needs to have the 16-foot length estimated to capture the entire deflection basin from a group of two tandem axles at an instant in time when the axle group is centered on the beam (Section 3.3). Since cantilevered end supports would not be subject to motion when an axle is nearby, a shorter beam could also be used, with the entire time history filling out the longitudinal extent of the deflection basin. The system also permits experimentation with just the beam half B, which would contain 8 pairs of LVDT sensors and 4 Migatron ultrasonic sensors, with the beam half B supported by cantilevers. (From the top, such a setup would look like Figure 2, except that the beam would be half as long).

3.2.2. Mechanical adjustment ranges

Neither longitudinal nor lateral profiles are necessarily straight. To accommodate up or down curvature, and lateral tilt or twist, vertical adjustments at the LVDT's and at the end supports are needed.

Each LVDT is gripped by a mount made of nylon and operating on the slit-block principle, so that tightening a single screw (6-32 socket head) tightens the hole in the nylon around the outer casing of the LVDT. The mounts are shown edge-on in Figure 4, and their detailed shop drawings are in the Appendix. To forestall thread-wear problems in the nylon, "SpeedSert" thread inserts (Groov-Pin Corp., Ridgefield NJ) will be installed. These mounts, fastened to the support beam as shown in Figure 4, permit vertical adjustment of each LVDT relative to the beam of ± 0.8 inch.

The slots in the simple end supports (visible as dashed lines in Figure 4) permit vertical adjustment of the ends of the beam relative to the ground of ± 0.8 inch. Sufficiently even distribution of compressive load at the slots in the end supports would be insured by $\frac{1}{2}$ inch thick aluminum clamping plates on the outside. (The dashed lines of their outlines are not shown in Figure 4.) Lateral leveling at each end can be accomplished by means of the bolt with jam nut, visible at left in Figure 4. (The other sharp-pointed support is partly hidden behind the contact tip for the LVDT close to the vehicle path in Figure 4.)

With ± 0.8 inch vertical adjustment at both the LVDT's and at the end supports, it is possible to have, in the case of a longitudinally curving road profile, the centermost LVDT's roughly 1.6 inch either higher or lower than (the average of) the end supports. Longitudinal leveling (road sloping in a straight line) is not expected to have any quantitative practical consequence, though some posttest corrections may be required in extreme cases, such as when slopes exceed fifteen degrees.

To put this vertical adjustment range into perspective, it is worth comparing it with the relation of downward curvature to the driver's sight distance. With a hill that can reasonably be represented by constant downward curvature (a shallow parabola), the downward elevation y at a horizontal distance x from the crest of the hill is given by

$$y = \frac{x^2}{2R} \quad (1)$$

where R is the radius of curvature. Equation (1) can also be inverted to give

$$R = \frac{x^2}{2y} \quad (2)$$

With $x = 8$ feet (half the total beam length) and $y = 1.6$ inch = 0.133 foot, Equation 2 gives $R = 240$ feet. Such would be a convex road indeed. In most passenger cars, eye height for the driver is about four feet. With $y = 4$ feet and $R = 240$ feet, Equation 1 gives approximately 44 feet for the sight distance x . Such a short sight distance would not permit passenger-car speeds to approach 25 mph. In arriving at this estimate, 0.5 second driver reaction time and 0.75 g deceleration in a panic-stop (ideal dry pavement conditions) were assumed.

Pavement sections with even more pronounced up/down curvature (roughly by a factor of 4) could be accommodated by the option of a single 8-foot beam-half (beam half B) supported by cantilever end-supports.

Thus, the vertical adjustment ranges in the proposed design (± 0.8 inch) do not impose a significant constraint on roads to be tested.

Flexibility in the positions of the Migration ultrasonic sensors is also built in. The 12.2 inch height above the road shown in Figure 4 assumes the height of the support beam is in its mid-range. Heights of 11-12 inches above the road are estimated to be sufficient in handling vehicles with tire sizes expected to be encountered. For example, on the M977 (10-ton) HMTT, the rim height above the road is approximately 13 inches. The mounts for the ultrasonic sensors also permit four lower heights, at 1 inch intervals, for experimentation.

Regarding positions of the Migration ultrasonic sensors in the lateral direction, in Figure 4 the ultrasonic sensor faces are shown exactly above the centerline of LVDT's closer to the vehicle, which is $\frac{1}{2}$ inch from the outer edge of the support beam. The Migatron RPS-8000A-12 system operates in the range 4 to 12 inches. Thus, the closest lateral distance of the truck tires from the edge of the beam (with the configuration as shown in Figure 4) would be 3.5 inches. This seems like a good starting point. Nevertheless, experimentation with even closer approaches of the tires to the edge of the beam is permitted, down to 2.5 inches. This can be attained by shifting the ultrasonic sensors, in their mounts (by $\frac{1}{2}$ inch) and relocating their mounts away from the vehicle (by $\frac{1}{2}$ inch); provisions for that are in the shop drawings in the Appendix.

3.2.3. Setup procedures

Any final instruction manual needs to be based on real hands-on experience, which so far we do not have. The following is offered only as an envisioned starting point. It is better to go to the field with an initial plan (subject to change) than no plan at all.

First, the boxes housing the beam halves, with sensors attached, would be unloaded from the transport vehicle. The beam halves would have been stored in their boxes with the LVDT sensors retracted to their uppermost positions. This would mean that their carbide-tipped probes would hang down approximately 0.4 inch below the lower surface of the support beam. (In Figure 4, they are shown 1.2 inches below.)

The tungsten carbide tipped probes proposed for the LVDT's have outer diameters of $\frac{3}{4}$ inch and a spherical radius of curvature of one inch, which were considered suitable for this application. (No. 336, Carbide Probes, Inc., Dayton, OH.) Spherical-tipped contact-points with the road serve to minimize sideways loads on the LVDT's while the highly wear-resistant tungsten carbide surfaces provide resistance to scratching, and therefore against increase in friction between probe and pavement caused by scratches. This implies that occasional sideways sliding of the beam with the LVDT probes in contact with the road surface could be tolerated, although it would probably be best to avoid it. By contrast, the

weight support-point contacts with the road surface, both with simple end-supports and with cantilevered end-supports, would have sharp-pointed tips to prevent sideways movements (and thereby safeguard the LVDT's) upon gentle accidental sideways hits.

The beam halves could then be set on the pavement, upon approximately 3 inch high wooden blocks at all ends, to keep the LVDT probes clear. Next, the middle joint in the beam would be joined. This takes four 3/8 - 16 high-strength alloy steel bolts, SAE Grade 8 or stronger. With the Grade 8 bolts, the weakest links at the joint are not the bolts but the welds joining the end plates to the beam halves, due to the annealing which occurs while welding (Machinery's Handbook 1993, Materials Selector 1992, Young 1989). Consideration was given for tapped (or thread-inserted) holes in one member, instead of the through-holes proposed. Desire for neutral twisting-torque on the support beam led to favoring through-bolts, with nuts and washers making it possible for a wrench on each end to provide equal and opposite torques so as not to tend to tip the beam inward or outward. Further experience may result in further improvements. (Thread-inserts can easily be retrofitted.)

It is assumed that experimentation would start out with the simple end supports, and that procedures used with the cantilevered end supports would benefit from experience gained with the simple end supports. Thus, we are focusing on using the simple end supports at this time. The end supports would be joined to the beam after joining the two beam halves.

With the simple end supports, the beam ends should first be located at the highest possible elevation. That is, referring to Figure 4, the holes in the beam ends (and the bolts) would be at the level of the top ends of the slots in the end supports, which are shown by dashed lines in Figure 4. The purpose of the initially maximum elevation is to keep the LVDT probe tips off the road initially. This initial attachment would be done while the beam ends are still supported by wooden blocks.

The support-points of the simple end supports will have pointed tips, with included angles of 90° close to the vehicle, and included angles of 120° at the ends of the L-shaped supports farther from the vehicle (Figure 4). The difference in included angles results from the desire to have the *primary* anchoring points close to the vehicle path, and close to the LVDT's closest to the vehicle path (rightmost in Figure 4). To attain sufficient resistance to tip-wear, as well as adequate strength for withstanding accidental sideways impacts, the support points would consist of high-strength alloy steel bolt material, SAE Grade 8 or stronger.

After the simple end-supports have been attached accordingly, a visual inspection of the beam and the (almost never straight) road profile would be made, from a vantage point to the side of the road. The goal of this inspection would be to estimate the height adjustment at each end so as to bring the difference between beam height and the road profile to $1.2'' \pm 0.8''$, that is, between a maximum of 2.0 inch and a minimum of 0.4 inch. This would be accomplished by loosening and retightening the four bolts at each end which fasten the end-supports to the beam. Following this, the end-supports should be reasonably leveled (a bubble-level will suffice) using the support screws (with jam nuts) shown at the left in Figure 4.

At this point (and also perhaps earlier) a sandbag would be placed over the L-shaped end of each simple end-support, as shown in Figure 1, to help stabilize it against tipping.

Once proper vertical adjustments and lateral leveling adjustments at the end supports are done, adjustments of individual heights at the LVDT's can begin. Each LVDT would be loosened in its mount, lowered and with the Spacer For Setting LVDT Heights Above Road (detailed drawing is on the last page in the Appendix) inserted between the carbide probe and housing of each LVDT, its position would be fixed by retightening its mount. The Spacer For Setting LVDT Heights Above Road is designed to balance on its support, so as to not occupy an operator's hand during adjustment. Thus, one hand can lift or lower the LVDT, while the other hand loosens / tightens the screw in the mount. This will set each LVDT to a height so as to be very close to the center of its sensing range (nominally high by 0.020"). With experience, the procedure should go quickly.

Once the heights of the LVDT's have been adjusted to the road profile, as above, the cables would be connected to the connector boxes on each half of the beam (Figure 3). The cables run to the signal-

conditioning system (Figure 5). At this point, electrical checkouts could begin. (The signal conditioning system was discussed in Section 3.1.)

After conclusion of data-taking at a given site, the cables would be disconnected and the LVDT's again retracted to their uppermost positions in their mounts, with their carbide-tipped probes hanging down approximately 0.4 inch below the lower surface of the support beam. The end supports could then be removed, and the beam halves disconnected and put back in their boxes. Or, in case of moving to the following test site, provided a truck with long enough bed length is available, the beam could be left assembled. Retraction of the LVDT's to their uppermost positions is recommended here as well.

3.3. Extents of Deflection Basins on Flexible Pavements

3.3.1. Review of data and choice of beam length between simple end-supports

As stated in the Introduction (Section 1), this is subject to the assumption that the pavement on the application area of secondary roads would be asphalt concrete, and not the much stiffer Portland Cement concrete. Likewise, slow drive-by speeds, comparable to parking the vehicle, are assumed.

A brief review of deflection basin extents and deflection magnitudes on various pavements is given in Hall 1996. The most pertinent information is reproduced here as well. Typical deflection basin measurements from the WASHO Test Road (1955), the AASHO Road Test (1962), and from Scullion (1993) are shown in Figures 6, 7, and 8, respectively.

Measurements at the WASHO Test Road were made with gages embedded in the pavement sections. The deflection contours were constructed by combining measurements from several passes of the truck. The greater longitudinal extent of the deflection basin, when compared with its transverse extent, is a notable feature. In Figure 6, in the transverse direction the basin is dissipated about 2 feet from the center of the *dual* wheels, while in the longitudinal direction deflection begins about 3 feet ahead of the axle and continues about 5 feet behind it. The deflection contours from the AASHO Road Test (1962, Figure 7), likewise with dual tires, are less asymmetrical in lateral versus longitudinal directions. The results from Scullion 1993 (Figure 8) show the deflection basin from a wide base single (which is more typical on Army trucks) extending only about 2 feet in front and to the rear of the axle, and less with dual tires.

It is already clear that deflection basins of flexible pavements under slow speed rolling conditions are not very great in their extent, especially in the lateral direction. For this reason, a *pair* of LVDT's at each location along the beam is proposed, so as to enable extrapolating from the deflections measured to deflections under the tires, by fitting a two-parameter curve. (This will be discussed in detail in the next section, Section 3.4.)

The *maximum* longitudinal extent of the deflection basins on some of the *stiffer* asphalt-concrete pavements, still at slow rolling speeds, is also of interest. This relates directly to how long the support beam needs to be when functioning with simple supports at its ends, given trucks with a tandem group of two axles 4.5 to 5 feet from each other.

Extensive data taken with the Falling Weight Deflectometer (FWD) are available. Part of this database, from four different states, was examined. These suggested basin extents of 6 to 8 feet from the drop point. But as it is well known that FWD data, due to the dynamic nature of the test, tend to produce wider basins than those obtained under rolling conditions at creeping speeds, the FWD data are at best only applicable to (perhaps overestimated) upper limits on deflection basin extent.

A more realistic estimate of upper limits on deflection basin extent on asphalt concrete pavements is obtained from Accelerated Traffic Test at Stockton Airfield, Appendix F: Results of Tests with Dual Tandem Wheel Assembly (1948). This involved a landing-gear configuration of four wheels; typical tire prints are shown in Figure 9. Center-to-center distance between the tandem wheels is approximately 62 inches (5.2 feet) in the longitudinal direction, not significantly different from the Army trucks of interest (4.5 - 5 feet). These tests also involved very high loads, up to 150,000 lbs. total on all the four wheels. The high loads (high aircraft weights) suggest that the runway pavement constructions on which these

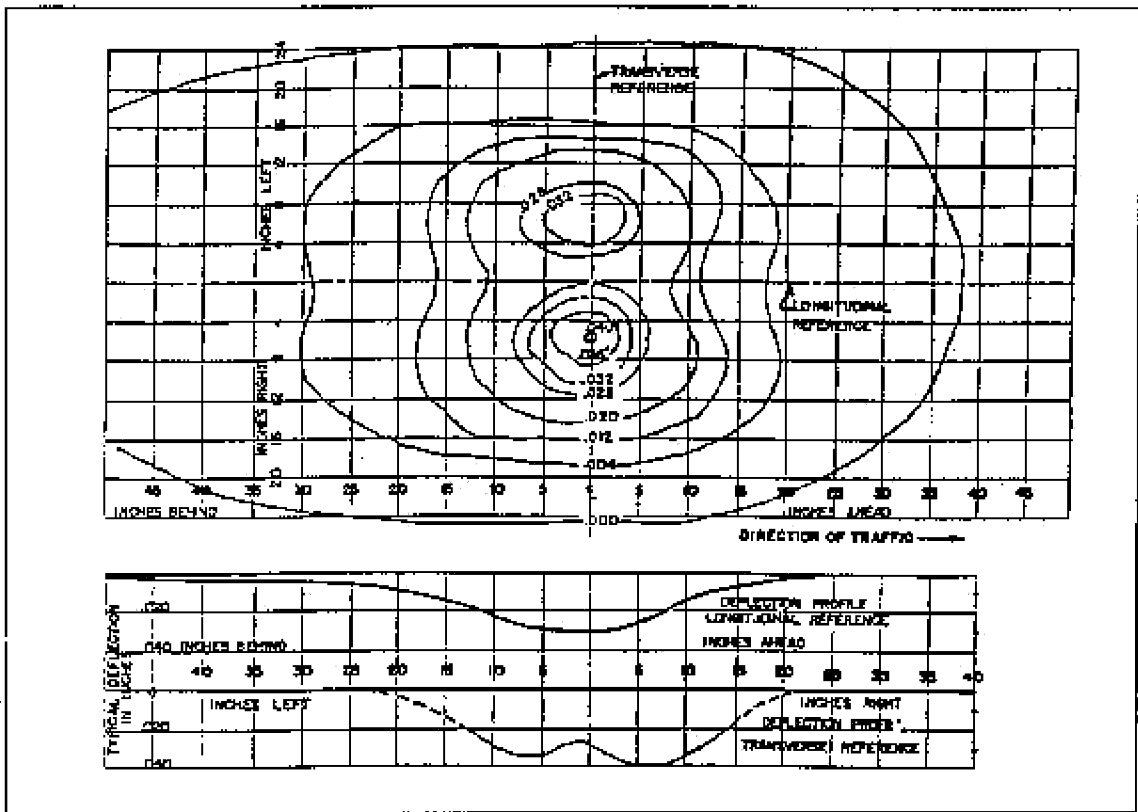

Figure 6. Deflection basin measurements from WASHO Test Road.

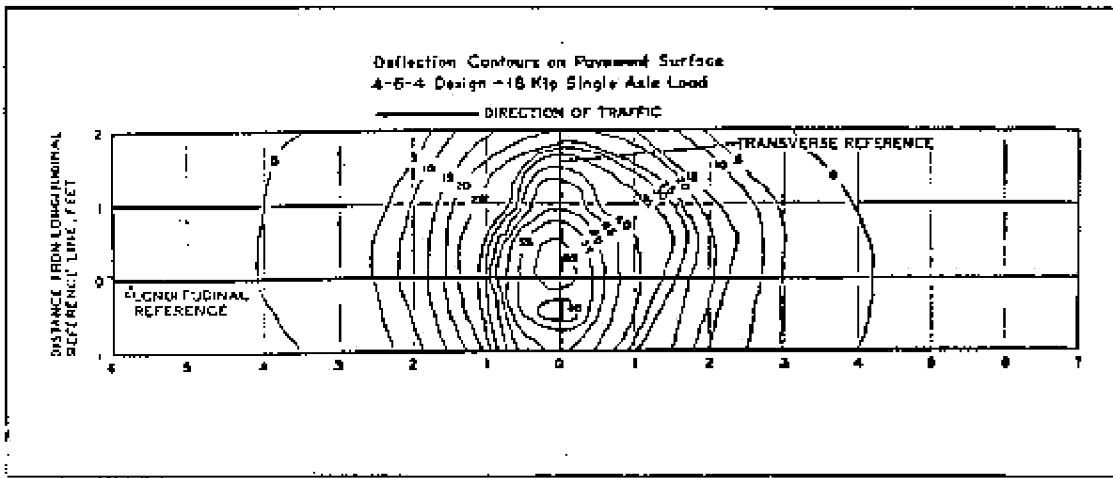

Figure 7. Deflection contours from AASHO Road Test

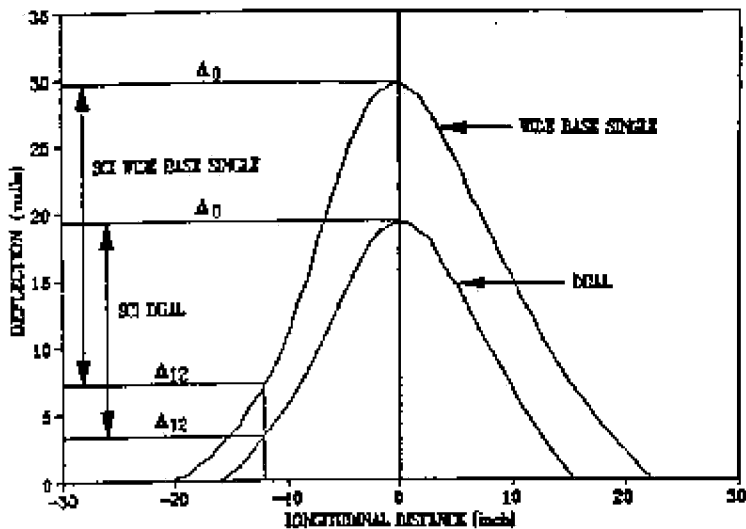

Figure 8. Deflection basin measurements from Scullion

tests were made were designed accordingly and therefore the data probably represent well what may be encountered at the upper limit of stiffness of asphalt-concrete pavements.

Resulting longitudinal deflection profiles, all with 150,000 lbs total on the four wheels, are shown in Figure 10. The four Item numbers in the figure refer to different pavement constructions. In all cases in Figure 10, it appears that the leading edge of the deflection terminates at approximately 90 inches (7.5 feet) in front of the center of the wheel grouping, while perhaps at a greater distance behind the wheel grouping.

Two of the Army trucks of primary current interest as loading vehicles are: (1) the medium-weight tactical vehicle (MTV), M1083, with spacing between tandem axles 55 inches (4.6 feet) and (2) the M977, 10-ton (HEMTT), with 60 inches (5 feet) between tandem axles in each group. In each of these cases, it appears that a 15-foot total measuring length (as attained by 16 LVDT pairs) and a total length between simple supports of 16 feet should be sufficient on almost all asphalt-concrete pavements.

Distance between axle-groups can also impact measurements with simple end-supports for the beam. For example, referring back to Figure 1 (page 4), if the truck were sufficiently shorter such that its front axle would be close to the end support for the beam while the tandem axle group is nearly centered on the beam, this would affect capturing the deflection basin loaded by the tandem axle group.

The MTV (M1083) has three axles, a front axle and two tandem rear axles. Distance from the front axle to the first rear axle is 134 inches (11.2 ft.). Half of this is 5.6 ft. This suggests that if the deflection basins reach out no more than 5.6 feet from both the front axle and the first rear axle, the deflection basin of the rear axle group could be captured when one of the simple end supports is located at that halfway point. Adding two times 5.6 feet to the 4.6-foot distance between the tandem rear axles gives a hypothetical total distance of 15.8 feet between simple end supports. The M977 (HEMTT) has groups of two tandem axles both front and rear. Distance between the rearmost axle in the front group and the first axle in the rear group is 150 inches (more than the 134 inches with the MTV).

From all of the above, it appears that with simple supports, a total length of 16 feet is appropriate for the support beam in that it is likely to produce good measurements on almost all asphalt-concrete pavements, with the Army trucks of primary interest. At the very least, it is a logical starting point for experimentation.

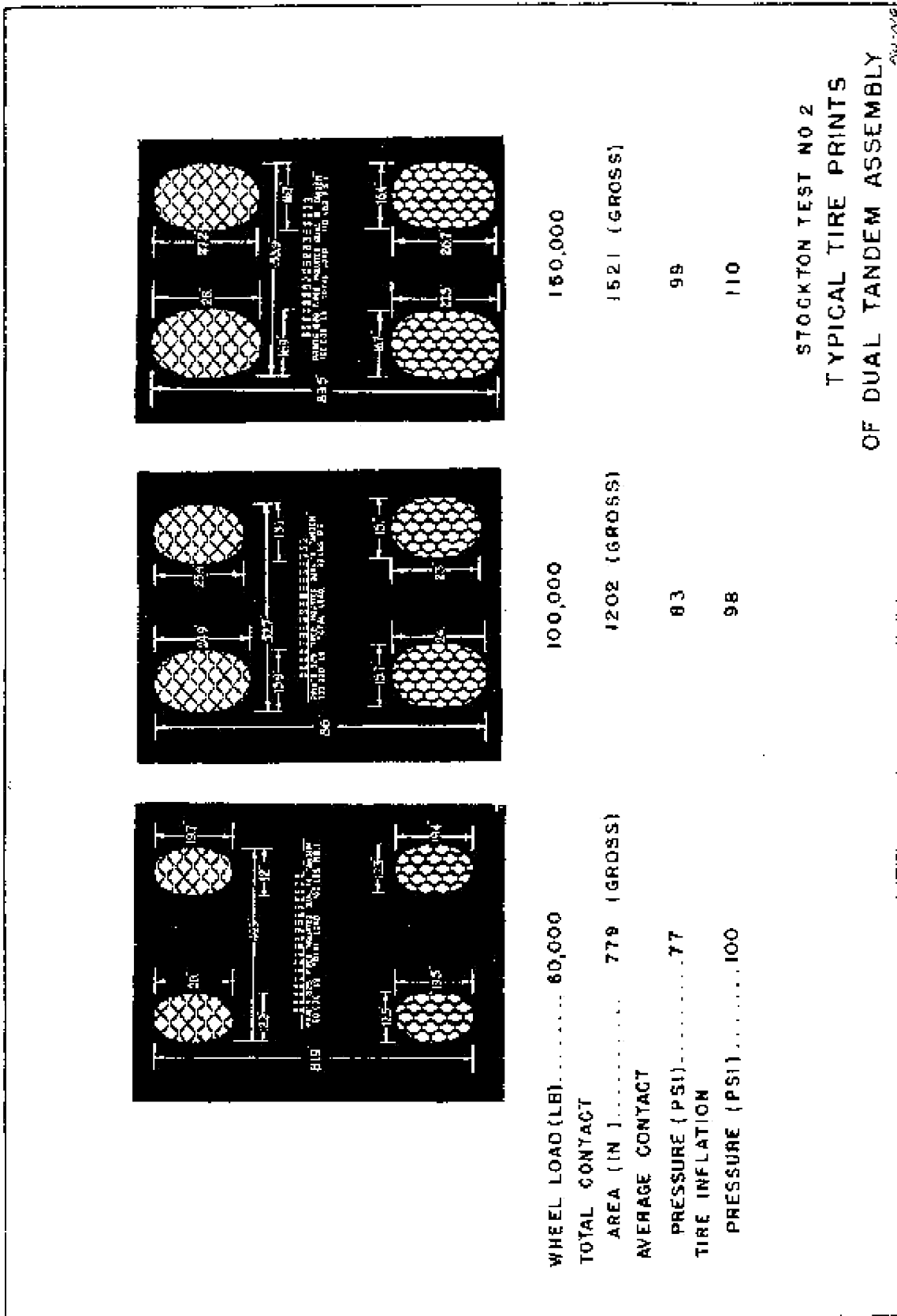

Figure 9. Wheel configuration in the tests at Stockton Airfield.

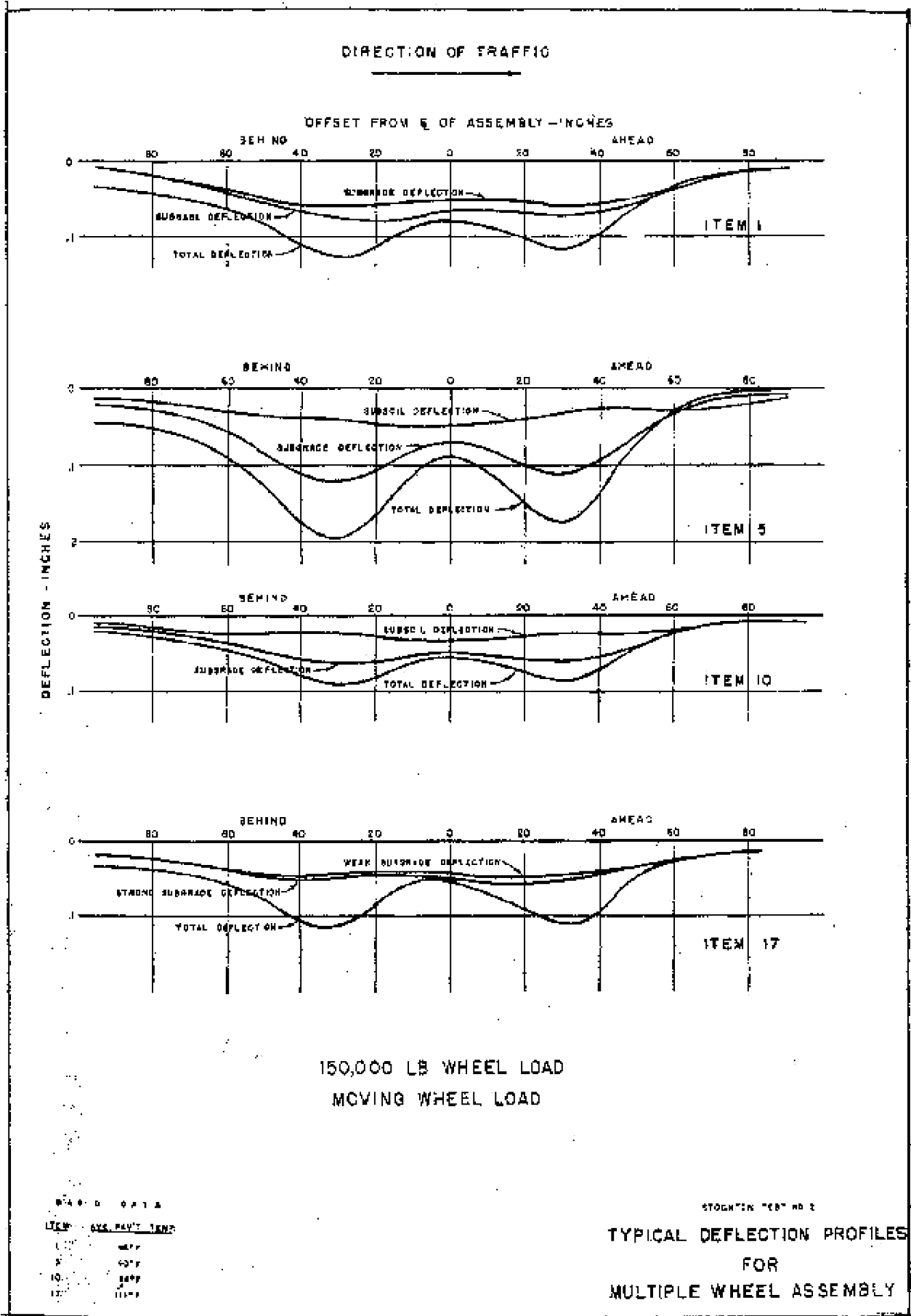

Figure 10. Typical longitudinal deflection profiles from tests at Stockton Airfield.

3.3.2. *Diagnostics for detecting movements of the beam ends.*

With the simple end supports, two diagnostic methods could be applied. The first would consist of examining the shape of the deflection basin recorded when the axle group of interest is centered on the beam. If the deflection basin (1) has very nearly zero slope at the ends, and (2) is symmetric about the center, then downward motion of the end supports (when the axle group is centered) can be considered negligible. Symmetry about the center of the deflection basin would imply lack of influence from the deflection basin of a different axle or axle group, to the front or to the rear of the beam. However this argument based on front-aft symmetry can also be influenced by viscoelastic events in the pavement which lead to shorter extent of the deflection basin in the forward direction, compared with the rear, as in Figure 6. At very slow drive-by speeds, such asymmetry would be less pronounced.

The other diagnostic method would consist of attaching sufficiently sensitive tilt sensors to the beam ends (or end supports), to sense tilt in the lateral direction. Any downward movement at an end support will also result in lateral tilt at that location (refer back to Figure 4, (page 11) for support point locations, and to Figures 6 and 7 for lateral extents of the deflection basins).

With the cantilevered end supports such as shown in Figure 2 (page 5), tilt sensors would be the best way to check/verify absence of motion of the beam ends. Referring back to Figure 2, if the deflection basin does not reach out laterally as far as the cantilever support points closest to the vehicle (shown in Figure 2 approximately 5.5 feet away), then there should be no tilt at the cantilevered end supports. This method will remain valid with a much shorter longitudinal support beam, such as just one beam-half (8-foot length). With such a shorter beam on cantilevered end supports, the entire deflection basin can be assembled from recordings at different instants of time.

The feasibility of detecting movements of the beam ends by means of tilt sensors depends on angular resolutions of available tilt sensors. Consider, for example, cantilevered end-supports with 60 inch distance between their contact-supports closest to the vehicle, to the line of LVDT's closest to the vehicle. In order to detect a downward movement of 0.001 inch at the beam, the tilt would have to be $0.001/60 = 0.000017$ radian = 0.001° .

The principal investigator met with representatives of two tilt sensor manufacturers at the Sensors Expo, June 2001. (At that time, the primary interest was potential application to a different project.) These were the Fredericks Company (Huntington Valley, PA) who offer glass-electrolytic sensors, and Nanotron (Tempe, AZ) who offer electrolytic sensors with non-glass construction.

A Fredericks Co. tilt sensor, 0719-1119-99, appears to be a prime candidate for our application. This sensor has an angular range of $\pm 3^\circ$, though the most sensitive resolution is attained near the null, at $\pm 1/3^\circ$. (The sensor would be adjusted to initially read zero by mechanical adjustment.) Resolution near the null is claimed to be better than 1 arc second, which is 0.0003° . This implies that these Fredericks Co. sensors, attached to cantilevered end supports with 5-foot distance between innermost support-points and the innermost line of LVDT's could resolve motions of the beam ends as low as 0.0003 inch. Their recovery (settling) time, approximately 0.5 second, should be sufficient in this application, considering the slow drive-by speeds.

The tilt sensors offered by Nanotron have several noteworthy features, including impact resistance, miniaturization, and excellent response times (approx. 20 ms) which make them suitable for dynamic applications. They do not extend down to as low sensing ranges and fine resolutions; their finest is $\pm 10^\circ$, resolution $\pm 0.001^\circ$. Thus, we do not consider their offerings competitive with the Fredericks Co. offerings for this particular application.

To date, we have not done a systematic survey of commercially available tilt sensors. The main point here is that using tilt sensors as diagnostic devices is eminently feasible.

In principle, recordings at different instants of time could also be used to correct for the effects of motion of the beam ends. The main reservation regarding this sort of procedure arises from considering effects of error propagation. That is, with elaborate calculations, especially when taking small differences, small

errors in the primary data can lead to much larger errors in the reduced, final data. In general, the more elaborate the calculations the worse the error-propagation effects. For this reason, the option of a simply-supported beam significantly shorter than 16 feet, which would depend on software corrections for the effects of motion of the beam ends, is *not* recommended.

3.3 Inferring Deflection Under the Tires from Deflections at the Sensors.

The deflections measured by the line of LVDT's closest to the vehicle (at right in Figure 4, page 11) provide good primary data. Together with the longitudinal deflection profile shape, they could be used to establish a relationship with the load capacity of the road. Nevertheless, inference of deflection *directly underneath* the tires would eliminate many uncertainties.

Some deflection basin data on asphalt-concrete pavements were reviewed in Section 3.3.1. A lateral deflection profile is given at the bottom in Figure 6. This shows that at less than 15 inches from the center of the *dual* tires, the deflection is already down to only about half its maximum value underneath the tires, and at two feet from the center of the load, the deflection approaches zero.

The approach proposed here consists of fitting a two-parameter curve to two measurements in x (horizontal distance in the lateral direction, outward from the tire centerline) and y (vertical deflection) coordinates. One parameter of the curve shape used would express the (maximum) deflection at the centerline, while the other would express the lateral extent. The exact shape of the curve would be determined by a more extensive survey of available deflection data on asphalt-concrete pavements, plus perhaps additional direct measurements on suitably instrumented pavements, involving different lateral positions of the loading vehicle.

At this time, the most detailed information we have is the lateral deflection profile shown at the bottom of Figure 6. This is for dual tires, but a reasonable first approximation for a single tire could be represented by the form

$$y = \frac{A}{2} \left(1 + \cos \frac{2\pi x}{\lambda} \right) \quad (3)$$

where A is the maximum deflection at the centerline of the tire and $\lambda/2$ is the lateral distance from the tire centerline to the point where the deflection becomes zero (and remains zero thereafter). The coordinates, together with the measurement points (x_1, y_1 , and x_2, y_2) are shown in Figure 11. In this cosine-curve approximation, the free parameters to be fitted are A and λ .

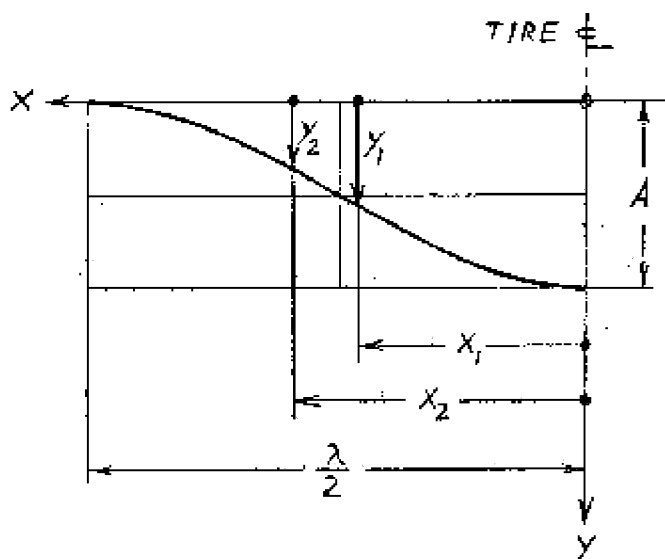

Figure 11. Cosine-curve approximation for the shape of the deflection basin in the lateral direction. The vertical coordinate (deflection) is greatly exaggerated.

Specifically, given the measurements x_1 x_2 (determined partly from the ultrasonic sensors) and y_1 y_2 (determined by the LVDT's), the equation

$$\frac{y_1}{y_2} = \frac{1 + \cos\left(\frac{2\pi}{\lambda}\right)x_1}{1 + \cos\left(\frac{2\pi}{\lambda}\right)x_2} \quad (4)$$

can be used to compute the quantity $(2p/\lambda)$. The deflection A at the centerline of the tire can then be computed from

$$A = \frac{2y_1}{1 + \cos\left(\frac{2\pi}{\lambda}\right)x_1} \quad (5)$$

A slight variant would involve using y_1 and the slope, that is y_1 and $y_1 - y_2$ as input coordinates. As the difference $y_1 - y_2$ is expected to be relatively small, there may be an advantage in amplifying $y_1 - y_2$ in the differential mode, in the signal conditioning package. When the differential mode is used, the equation

$$\frac{y_1}{x_2 - x_1} = \frac{1 + \cos\left(\frac{2\pi}{\lambda}\right)x_1}{\left(\frac{2\pi}{\lambda}\right) \sin\left[\left(\frac{2\pi}{\lambda}\right)\frac{x_1 + x_2}{2}\right]} \quad (6)$$

would be used to solve for $(2p/\lambda)$. Again, once this is determined, Equation 5 would be used to solve for A . The cosine-curve approximation offered in the above examples does not necessarily represent the lateral deflection profile except as an approximation which illustrates how the fit could be done.

The cosine-curve approximation necessarily involves a trial solution (Equation 4 or 6). On the other hand, an assumed curve permitting a closed-form solution provides a much more convenient assessment of error-propagation effects. To this end, the curve shown in Figure 12 is offered, in which the end thirds are constant curvature (parabolic), and the middle third is linear. It does not differ greatly from the cosine-curve approximation.

In this case, provided that $x_1 > \lambda/6$ and $x_2 < \lambda/3$, the deflection at the centerline of the tires A is given by

$$A = \left[\frac{4x_1}{5(x_2 - x_1)} + \frac{4}{5} \right] y_1 - \frac{4x_1}{5(x_2 - x_1)} y_2 \quad (7)$$

Applying the theory of propagation of *random* errors to the above, assuming x_1 and x_2 well determined and random errors s_{y1} and s_{y2} in y_1 and y_2 respectively, the resulting error in A , s_A is given by (Parratt 1961)

$$\sigma_A = \sqrt{\left(\frac{\partial A}{\partial y_1}\right)^2 \sigma_{y_1}^2 + \left(\frac{\partial A}{\partial y_2}\right)^2 \sigma_{y_2}^2} \quad (8)$$

Applying Equation 8 to Equation 7, when additionally $s_{y1} = s_{y2} = s_y$ gives

$$\frac{\sigma_A}{\sigma_y} = \frac{4}{5} \sqrt{\left(\frac{x_1}{x_2 - x_1} + 1\right)^2 + \left(\frac{x_1}{x_2 - x_1}\right)^2} \quad (9)$$

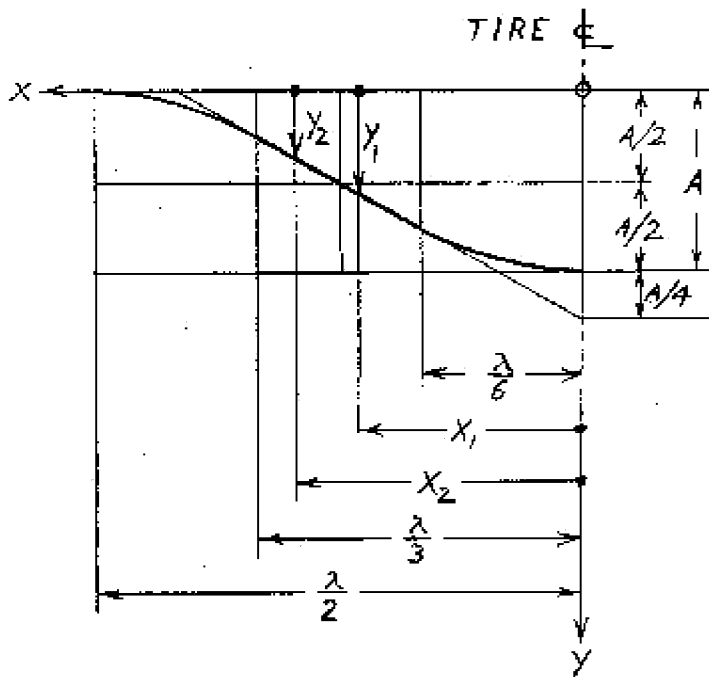

Figure 12. Approximation for the shape of the deflection basin in the lateral direction consisting of linear and parabolic segments. The vertical coordinate (deflection) is greatly exaggerated.

Some results from Equation 9 are shown in Table 1. In Table 1, the examples are shown in which $\lambda/2 = 24$ inches and $x_1 = 12$ inches while $x_2 - x_1$ varies. The distance $x_2 - x_1$ is the distance between LVDT's in each pair.

Table 1. Error in s_A due to random errors s_y in y_1 and y_2 , expressed as s_A/s_y , with $\lambda/2 = 24$ and $x_1=12$		
$x_2 - x_1 = 2$	$x_2 - x_1 = 3$	$x_2 - x_1 = 4$
7.376	5.12	4.00

Thus, in this example a four inch lateral spacing between LVDT's in each pair would offer almost a factor of 1.8 better accuracy than with two-inch spacing. With larger spacings, the returns diminish. In an extreme case, locating x_2 and y_2 entirely outside the deflection basin would result in loss of essential information. Based on current knowledge, the spacing $x_2 - x_1 = 4$ inches appears optimal. At this particular spacing, with a random error at each LVDT of 0.0001 inch (easily attainable), the corresponding random error at the tire centerline would be 0.0004 inch. This would not be excessive.

However beyond that, we also have to face systematic uncertainties such as due to assuming the wrong shape for the lateral deflection profile. As mentioned earlier in this section, such uncertainties can be diminished by further work on defining the lateral shapes of deflection basins more precisely.

4. EVALUATION OF ULTRASONIC SENSORS

Because Migatron Corporation offered to furnish us a loaner unit of their RPS-8000A-12 system ("try before you buy"), at no cost beyond shipping charges, we decided to include evaluation of their sensor system in Phase I, instead of in the next stage, the SBIR Phase I Option as originally proposed. This was carried out in Vicksburg, MS, at Pick Associates, and included a demonstration at the ERDC.

The objective of our evaluation was to determine if the Migatron sensors would be suited for the needs of this project. Thus, the precision that would be required to meet or exceed their own laboratory evaluations was not deemed necessary. Migatron specifications mention accuracy of ± 0.040 inch (1 mm).

The simple fixtures we used were designed for comparable accuracy in measurements of actual distance between sensor and target. Also, we considered multiplexing (used by Migatron to eliminate cross-talk between different channels) to be sufficiently well established as to not require an independent evaluation. Thus, our evaluation was restricted to a single channel.

We saw that the system has no problem in sensing mechanically soft, flexible and even very thin targets, such as a human hand or a sheet of paper.

We investigated the limits of the sensing range, which for the RPS-8000A-12 system is specified as 4 inches to 12 inches. This was done without first calibrating the system. The results are shown in Figure 13. Note the excellent linearity in the 4 to 12 inch specified range. Within this range, the point-scatter is well within the 0.04 inch (1 mm) accuracy specified.

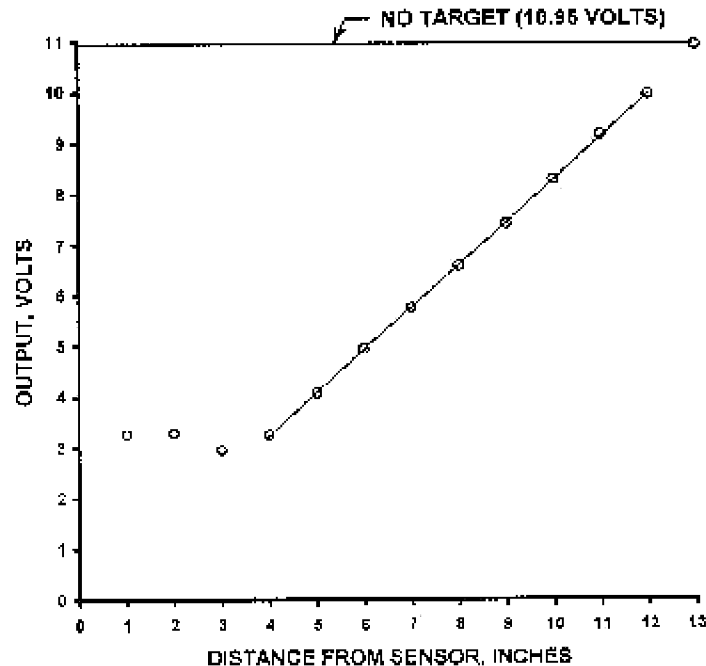

Figure 13. Linearity in the 4" to 12" range

Next, we investigated the effects of the angle of the target surface with respect to the ultrasonic beam of pulses. The Migatron specifications state $\pm 8^\circ$ deviation from perfect perpendicularity of the beam with the target. One of the effects we wanted to resolve was the question of any degradation of the signal before the limit is reached. This was done starting at two distances, 4 inches and 8 inches. With the test rig used, varying the angle was coupled with variation in distance. The results are shown in Figure 14.

In Figure 14, the + shaped points, from the investigation of angular dependence, line up very well with the previous data. Starting at the 4 inch range, the angular-dependence data fit well along the line through an angular deviation of 12° from perfect perpendicularity, recorded at intervals of 5° , 8° , 10° , 11° , and 12° . Around the zero-point of 8 inch range, data at intervals of $\pm 5^\circ$, $\pm 8^\circ$, $\pm 10^\circ$, $\pm 12^\circ$, and $\pm 13^\circ$ likewise show no significant deviation. (The fact that all the + shaped points lie slightly high may be due to a temperature change, as no attempt was made to compensate for temperature between these tests.) The Migatron spec's of $\pm 8^\circ$ were well met in that *no* discernable degradation showed up below that limit, and in our evaluation the limit extended to 12° magnitude.

After this, the Migatron sensor system (RPS-8000A-12) was calibrated, according to their instructions/specifications, and a sensor was set up with a vehicle tire as the target. The vehicle was a 1993 short-wheelbase Toyota pickup truck, tire size P195/75R14. Height of the lower part of the wheel rim above the pavement was 4.25 inches. Sensor height was set at 5 inches above the pavement. This was done in order to make sure that the ultrasonic pulses would not bounce off the bulge in the tire

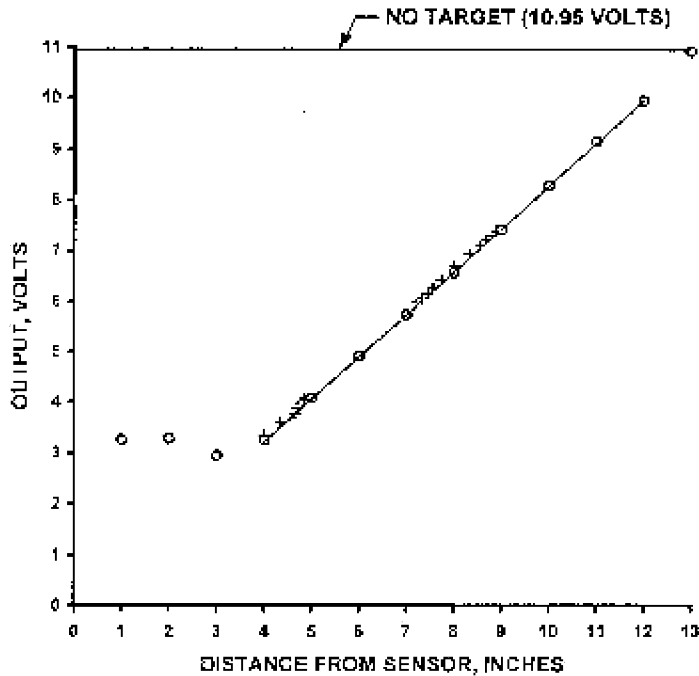

Figure 14. Plot of Figure 13 with + shaped points added from investigation of angular dependence.

sidewall near contact with the pavement, as the size of this bulge would be excessively sensitive to tire pressure. Instead, we made sure that the sensor was aimed above this. Thus, as a tire would pass a sensor, two minima in measured range would occur, one when the widest part of the front of the tire is opposite the sensor, and another when the widest part of the rear half of the tire is in that position.

With the sensor output hooked to an oscilloscope, the shape of the time history could be seen, and in all cases it showed the double minimum in range that was expected. The oscilloscope used was not a memory-scope, which made the trace difficult to follow, but the shape was verified by having both Jim Pickens and Andres Peekna taking turns in observing the output vs. driving the vehicle.

Static distance data were taken with the output fed into a digital voltmeter. The static data were taken at three different distances, first close to mid-range, at 7.75 inches, then close to the outer range, at 11.31 inches, then close to the inner limit, at 4.8-4.9 inches. In each case, the vehicle was stopped at positions judged optimal to sense widest portions of the tire, both front and rear. Thus, a total of six measurements. The results are shown in Table 2.

Actual range	Position on tire	Range from sensor output	Sensor output minus actual
7.75	Front half	7.804	0.054
7.75	Back half	7.864	0.114
11.3125	Front half	11.336	0.024
11.3125	Back half	11.348	0.036
4.8125	Front half	4.913	0.100
4.9375	Back half	4.972	0.034

The average value of the sensor output minus actual is 0.060 inch, and the root-mean-square (rms) deviation about this value is 0.034 inch. We suspect that the high bias of 0.060 inch is due to a temperature drop, as the system was calibrated earlier in the afternoon and the tests took place toward evening. A 4°F temperature drop (according to formula supplied by Migatron) would account for this effect. While we did not record the temperatures, nor compensated for temperature effects in any other way, a 4°F temperature drop seems reasonable. The rms deviation of 0.034 inch is within the Migatron specification of 0.040 inch (1 mm) accuracy.

The 8-channel Migatron RPS-8000A-12 system comes with a built-in provision for automatic temperature compensation, in which one of the 8 channels looks at a fixed target while the other 7 are left free for ranging measurements. Thus, in actual field application, temperature compensation should be no problem. We did not evaluate this particular feature.

The final exercise was a demonstration at the ERDC. After briefly reviewing the data, it was decided to do it under a hangar, using a tire for a commercial truck, a super-single 425/65R225 G286 (on its wheel) as a target. The outer diameter of this tire was approximately 44 inches, and the height of the lower part of the rim above the pavement was approximately 10.25 inches. The sensor height was set 11 inches above the pavement. The tire was rolled past the sensor by hand. The ERDC made a memory-scope available for this demonstration.

A resulting trace is shown in Figure 15. This is not from a photograph, but copied from an on-site sketch. It clearly shows the as-expected shape, with the two minima. The minimum values in distance would fix the lateral distance between the sensor and the tire during the drive-by. Provided that the vehicle speed is reasonably constant, the average of the two time-values at the minima would determine the time at which the longitudinal location of the axle was even with the sensor.

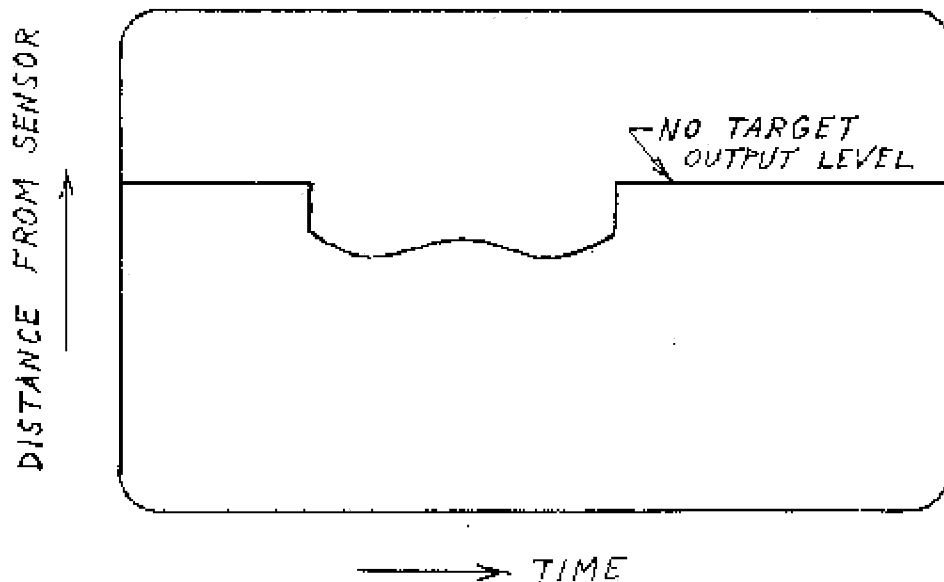

Figure 15. Oscilloscope trace from ultrasonic sensor, with roll-by of super-single truck tire.

Our brief evaluation of the Migatron RPS-8000A-12 system showed it to be suitable for this project.

5. ACKNOWLEDGEMENTS

We would like to thank Reed Freeman and other ERDC personnel for helping with the above demonstration. We would also like to thank Reed Freeman for pointing out feasibility of cantilevered end supports with their own support points on the pavement (Figure 2), as blocking an entire driving lane on a two-lane secondary road during setup would not disrupt traffic any more than blocking part of a lane. Likewise for consistently providing us with other needed information, such as configurations of Army trucks of interest, in a very timely way.

6. CONCLUSIONS

Because drive-by conditions permit using sensors in contact with the road, the survey of sensor technologies resulted in choosing linear variable differential transformer (LVDT) displacement sensors for measuring pavement deflection. The LVDT is a proven gage, which has been used in displacement measurements for over 50 years. The specific model chosen for this particular application was RDP Electrosense (Pottstown PA) D5/200AG, with ± 0.20 inch range and spring-return probe.

For sensing both the lateral and longitudinal position of the tires from the LVDT sensors, a sideways-looking multiplexed array of ultrasonic sensors, the RPS-8000A-12 system by Migatron Corporation, Woodstock, IL was chosen. The multiplexing eliminates crosstalk between channels. Experimental evaluation of the Migatron RPS-8000A-12 (Section 4, pages 24-27) showed it to be suitable for this project.

Review of published data on deflection basins on asphalt-concrete pavements brought out the fact that, due to their relatively small horizontal extent, deflection as close as 4 inches from the edges of the tires would not represent the deflection under the tire centerlines. (The widths of the tires are of the order of 1 foot while the lateral widths of typical deflection basins are of the order of 2 feet.) For this reason, a *pair* of LVDT's is proposed at each longitudinal location, in order to make possible extrapolating to the deflection under the tire centerline not by guesswork but by fitting a two-parameter curve.

Instead of attempting to design for optimum performance with minimum unit cost right away, the prototype is designed for versatility in foreseeable field experimentation. The sensors will be mounted on a lightweight aluminum support beam. A beam of 16-foot length with simple supports at its ends is shown in Figure 1 (page 4). This would support 16 pairs of LVDT sensors and 7 ultrasonic sensors. A bolted joint at its middle enables transport in a relatively small vehicle (such as a HMMWV).

Another option involves cantilever end supports reaching out from near the edge of the pavement, but still on the pavement. This scheme is shown in Figure 2 (page 5). Sandbags would counterbalance the weight of the sensor support beam. The contacts of the cantilever end supports would be located sufficiently far to the side so as to be well outside the deflection basin. (In Figure 2, the distance shown from the vehicle edge to the closest contacts of the cantilever end supports is approximately 5.5 feet.)

The end supports cantilevered from the side have the advantage that the end-points of the sensor-support beam do not move even when there is an axle next to either beam end. On the other hand, the option with the simple end-supports (shown in Figure 1, page 4) depends on not having an axle near a support point, at the instant when the deflection basin is captured. As the end supports cantilevered from the side (with proper design and verification) would not move under any conditions, significantly fewer sensors, with a correspondingly shorter sensor-support beam, could also be used. The design permits experimentation with just one 8-foot beam-half, which would have 8 pairs of LVDT's and 4 ultrasonic sensors. Beyond that, in order to investigate the tradeoffs involved in using even *fewer* channels, with *either* option, it is simple to disconnect some channels in the field recordings under otherwise identical conditions. This would cost significantly less than modifying the hardware to add additional sensors.

To detect/verify absence of motion at the end supports, sufficiently sensitive tilt sensors are proposed. To date, a systematic survey of commercially available tilt sensors has not been done. A Fredericks Co. (Huntington Valley, PA) tilt sensor appears to meet the accuracy requirements called for here. Using tilt sensors for this purpose appears feasible.

Assembly drawings showing the sensors in their mounts on the support beam are shown in Figures 3 and 4 (pages 10 and 11). Shop drawings for the support beam and gage mounts are in the Appendix. The only parts not yet designed in detail are the cantilevered end supports and the mounts for the tilt sensors at the ends.

We are essentially ready to build a prototype system. Such level of maturity was originally proposed for the end of the next stage, the SBIR Phase I Option, but we are very close to it at the end of Phase I.

7. REFERENCES

“The AASHO Road Test, Report 5, Pavement Research”, Highway Research Board Special Report 61E, Washington, DC, 1962.

“Accelerated Traffic Test at Stockton Airfield, Stockton, California (Stockton Test No. 2)”. Prepared by O.J. Porter and Co., Consulting Engineers, Sacramento CA for the US Army Corps of Engineers. Appendix F: Results of Tests with Dual Tandem Wheel Assembly. May 1948.

Hall, Jim W. Jr., “Prediction of Deflection Response of Flexible Pavements Under Dynamic Loads”, PhD Dissertation, Auburn University, Alabama, 1995.

Hall, Jim W., Jr. “Rolling Wheel Deflection for Highway Pavements”, SBIR Phase I Interim Report Number One, prepared for Federal Highway Administration. Applied Research Associates, Inc., Vicksburg, MS, May 1996.

Machinery's Handbook, 24th Edition, by E. Oberg, F.D. Jones, H.L. Horton and H.H. Ryffel, Industrial Press Inc., New York, NY, 1992.

“Materials Selector 1993”, *Materials Engineering*, December 1992.

Parratt, L.G., *Probability and Experimental Errors in Science*, Wiley, New York, NY, 1961.

Scullion, Tom, “Using the Multidepth Deflectometer to Study Tire Pressure, Tire Type and Load Effects on Pavements”, Research Report 1184-2, Volume 2, Texas Transportation Institute, November, 1993.

“The WASHO Road Test, Part 2: Test Data, Analyses, and Findings”, Highway Research Board, Special Report 22, Washington, DC, 1955.

Young, W.C., *Roark's Formulas for Stress and Strain*, 6th ed., McGraw-Hill, New York, NY, 1989.

APPENDIX
SHOP DRAWINGS FOR THE SUPPORT BEAM AND GAGE MOUNTS

Dimensions in inches on these drawings may be converted to millimeters by multiplying by 25.4.

I-BEAM IS
ALUMINUM
ASSOCIATION
4 X 0.150
6061-T6

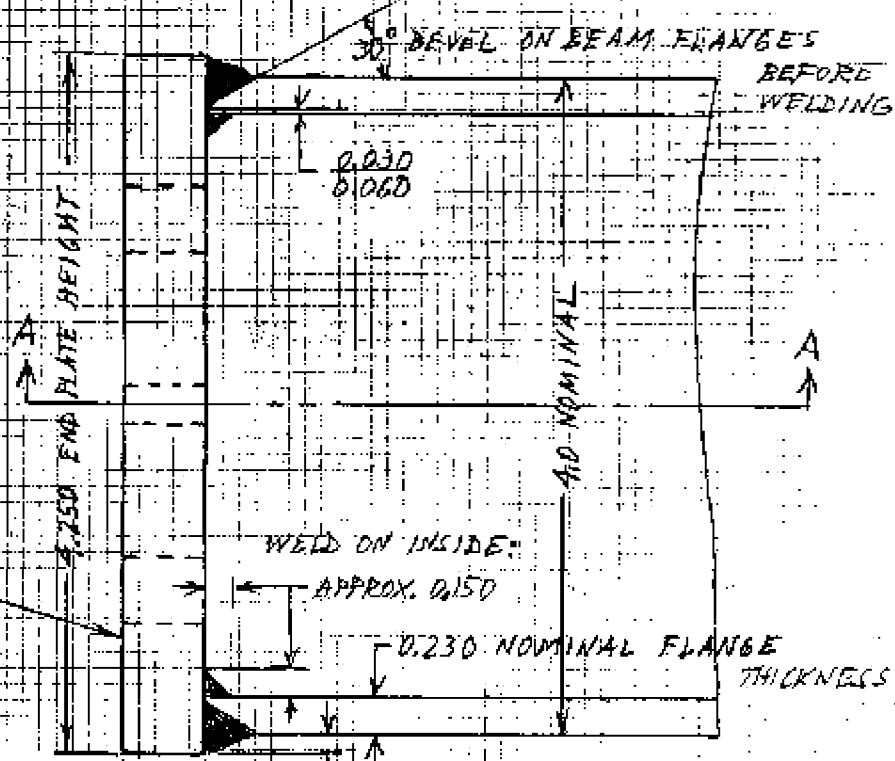

CLEANUP CUT
ON OUTER FACE
REQUIRED
AFTER WELDING.

AT CENTER
JOINT IN BEAM,
THE CLEANUP
CUTS MUST BE
SUCH THAT THEY
MINIMIZE
NON-STRAIGHTNESS
OF THE BEAM
OVERALL.

THIS MAY TAKE
MORE THAN
ONE TRY.

BREAK EDGES
AROUND CLEANUP
CUT $\frac{1}{32}$.

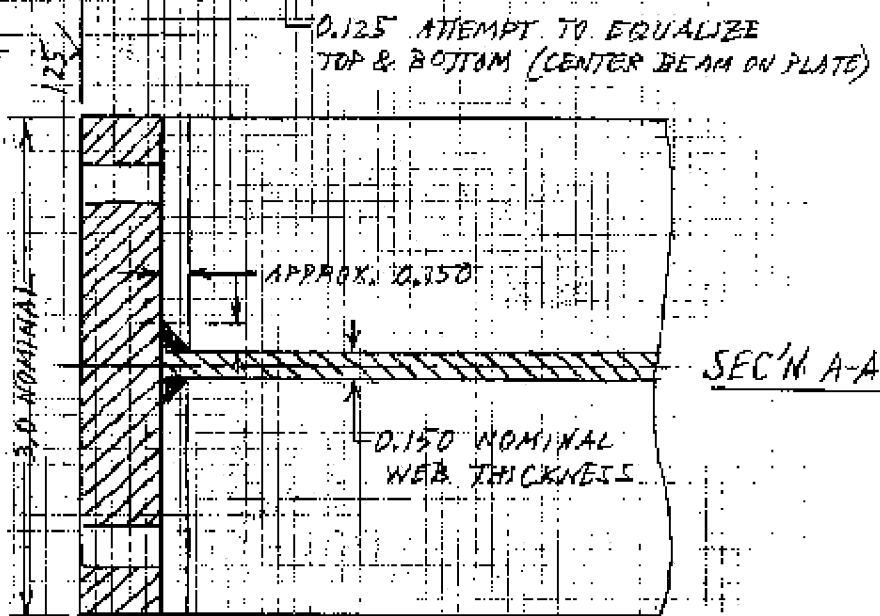

0.125 ATTEMPT TO EQUALIZE
TOP & BOTTOM (CENTER BEAM ON PLATE)

APPROX. 0.150

0.150 NOMINAL
WEB THICKNESS

0.150 NOMINAL (BEFORE CLEANUP CUT)

TO OUTER FACE OF OPPOSITE END PLATE: $96 \pm \frac{1}{16}$

WELDING DETAILS AT END PLATES

INNOVATIVE MECHANICS, INC. 265 COE RD., CLAR. HILLS, IL 60514-1029
TEL/FAX: (630) 887-9020 TEL: 887-8478 A. PEEBLES 2001-12-31

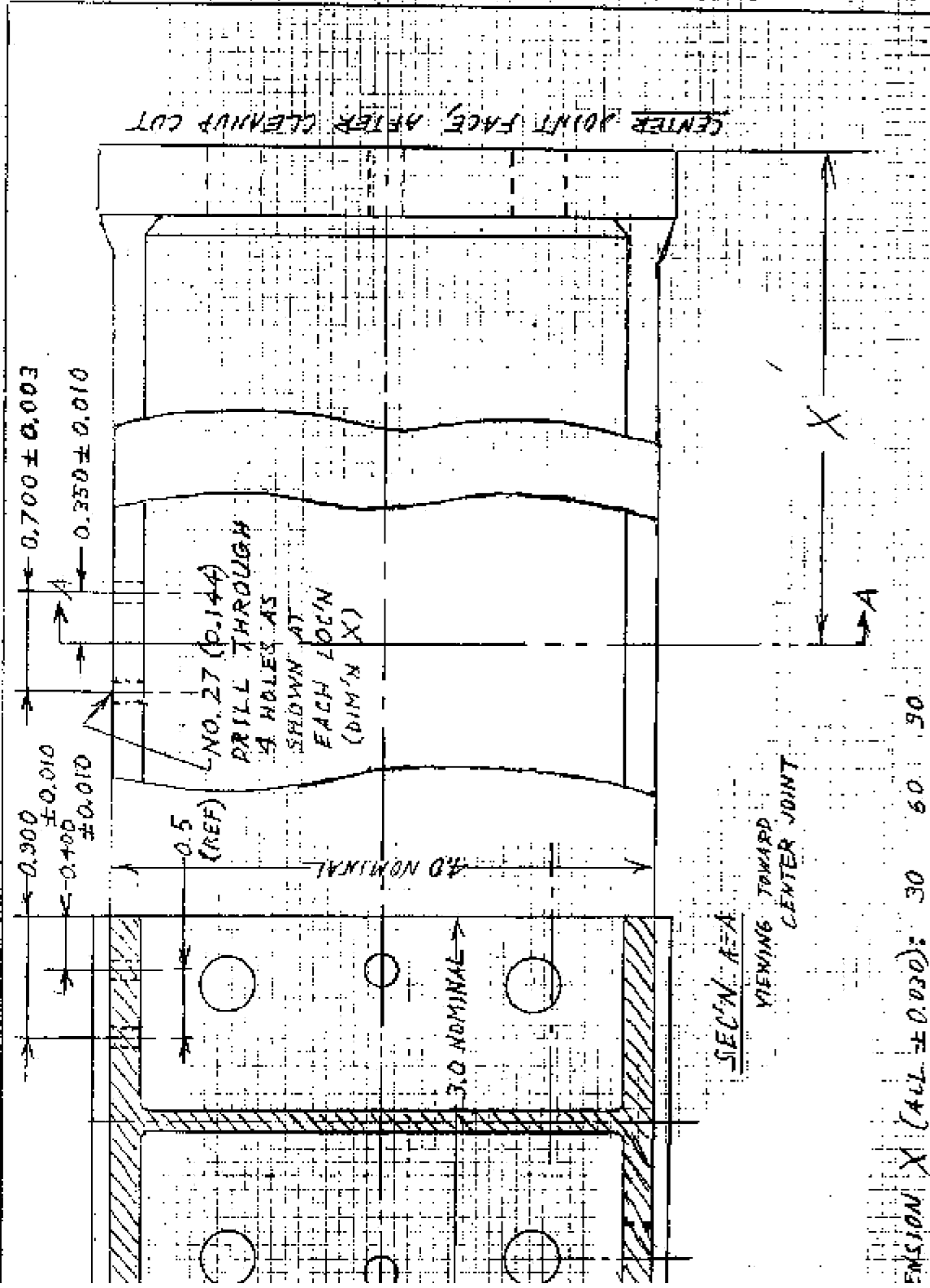

EMISION X (ALL ± 0.030): 30 60 90

BEAM IS ALUMINUM
CIATION 4 X 0.150
1-T6

HOLE DETAILS AT ULTRASONIC SENSOR LOC'NS, BEAM HALFA

INNOVATIVE MECHANICS INC. 265 COE RD., CLAR. MILLS IL 60514-1029
TEL/FAX (830) 887-3020 TEL: 887-8478 A. PEEBKA 2002-1-1

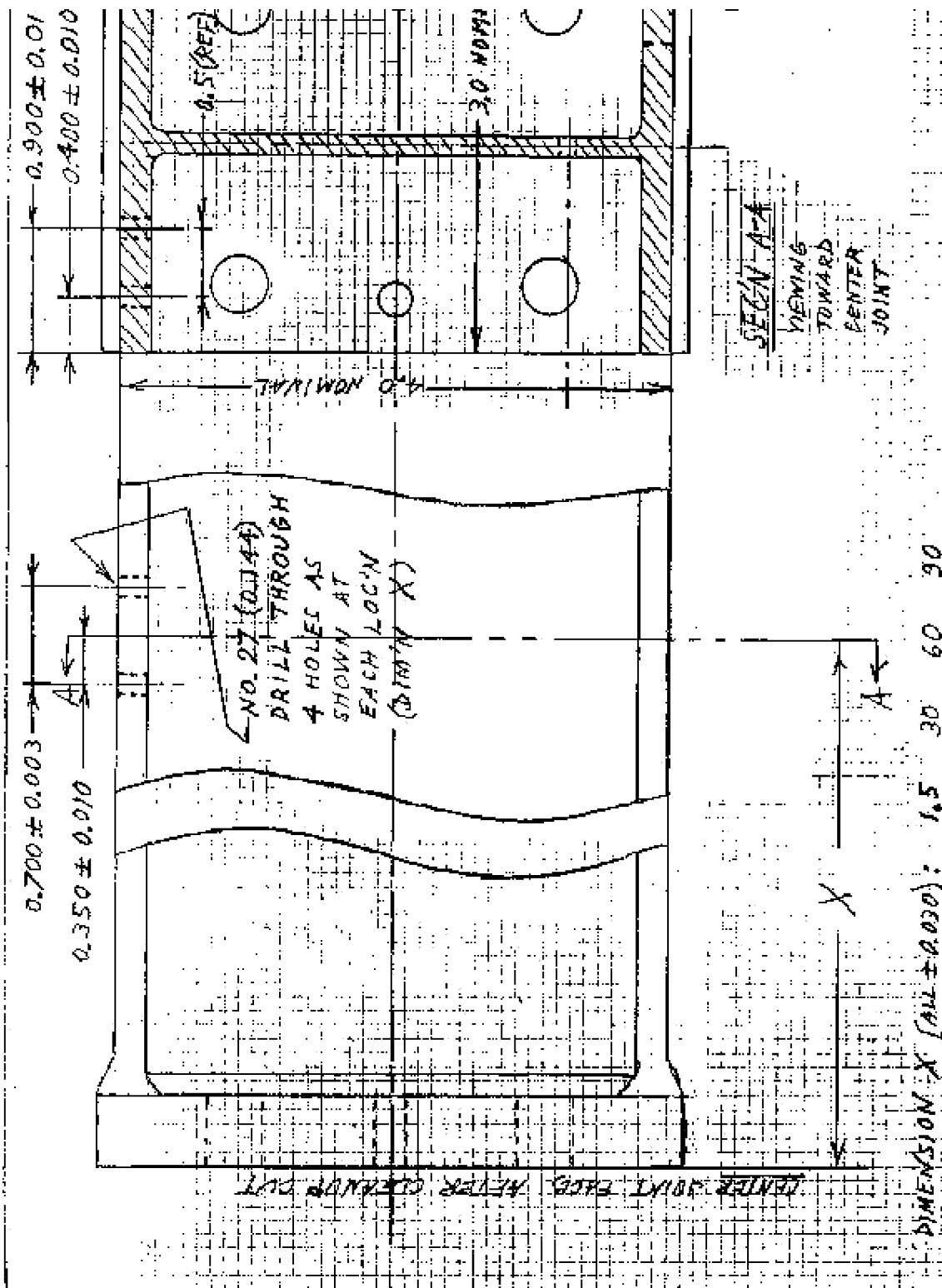

HOLE DETAILS AT ULTRASONIC SENSOR LOCALS, BEAM HALF B

INNOVATIVE MECHANICS, INC. 265 COE RD, CLAR, MISS IL 605

TEL/FAX (630) 887-9020 TEL 887-8478 A. PEEBIA 2002-1

I-BEAM IS ALUMINUM

ASSOCIATION 4 X 0.150

6061-T6

NO. 27 (0.144) DRILL THROUGH
2 HOLES AS SHOWN

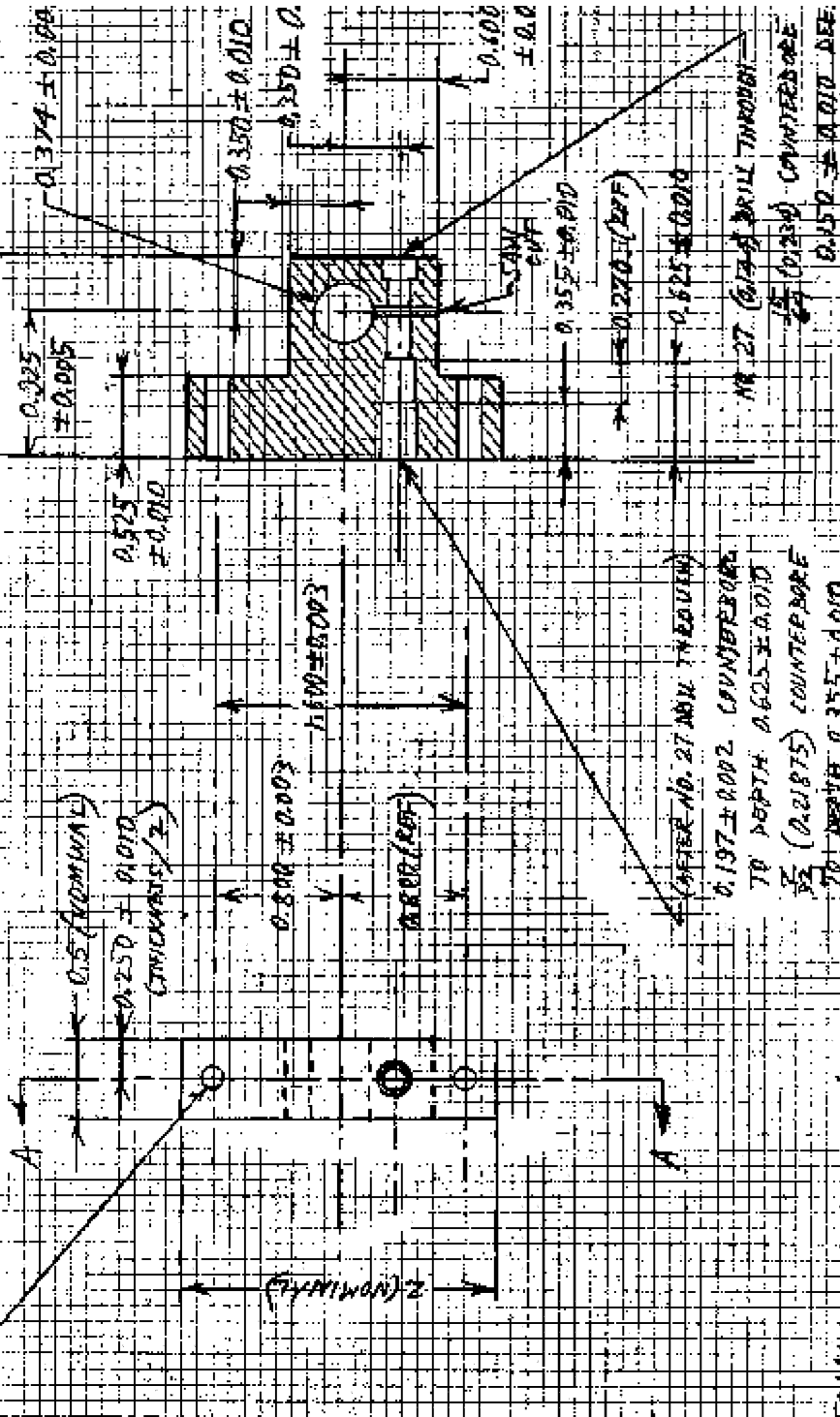

MATERIAL HARD NYLON
OR EQUIVALENT
(CADILLAC PLASTIC, ELEMENT 12)
2 X 1/2 INCH BAR

DIMENSIONS IN INCHES

SECTION A-A

SECTION B-B

MOUNT FOR LVDT SENSOR, MODEL DED-I

INNOVATIVE MECHANICS, INC. 265 COE RD. CLEAR HILLS IL 60514-10
TEL/FAX (830) 887-8020 TEL: 887-8478 A. PEERMAN DEC. 22, 2001

NO. 27 (0.149) DRILL THROUGH
 15° COUNTERBORE 0.150 ± 0.010 DEEP
 64

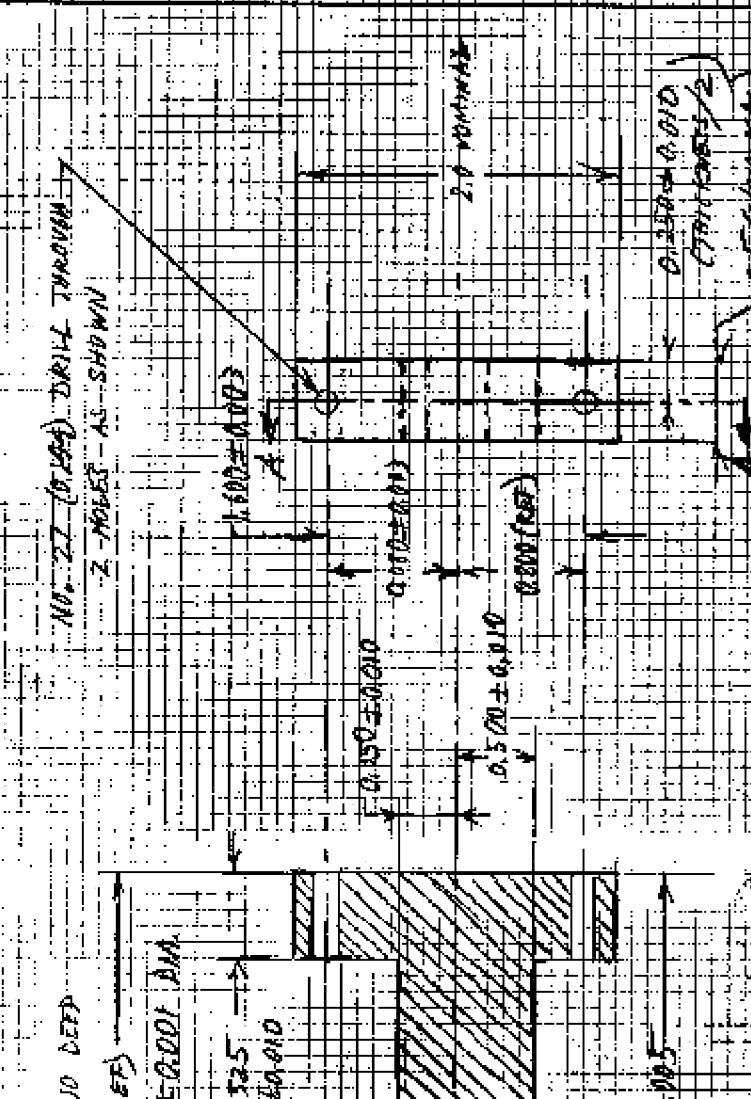

AFTER NO. 27 DRILL THROUGH
 0.157 ± 0.002 COUNTERBORE
 TA DEPTH 0.280 ± 0.010

SECTION A-A

MATERIAL: ENCO NYLON
 OR EQUIVALENT CARBIDEAL ALANTIG, EMWURST, 14 2X 1/2 INCH DIA)

1/8 INCHES IN INCHES

MOUNT FOR LYDT SENSOR, MODEL 225-D

IMPROVATIVE MECHANICS, INC. 265 COE RD. CLEAR HILLS, IL 60514-1029
 TEL/FAX (630) 827-9020 TEL 827-8478 "A. PEERVA" DEC. 22, 2001

1/16 DRILL THROUGH, 5 HOLES. LONGITUDINAL LOC'NS AT 1.0 INTERVALS STARTING FROM 3.000 FROM SHORT OUTER FACE. TOLERANCE IN LOC'NS RELATIVE TO SHORT OUTER FACE: ± 0.010

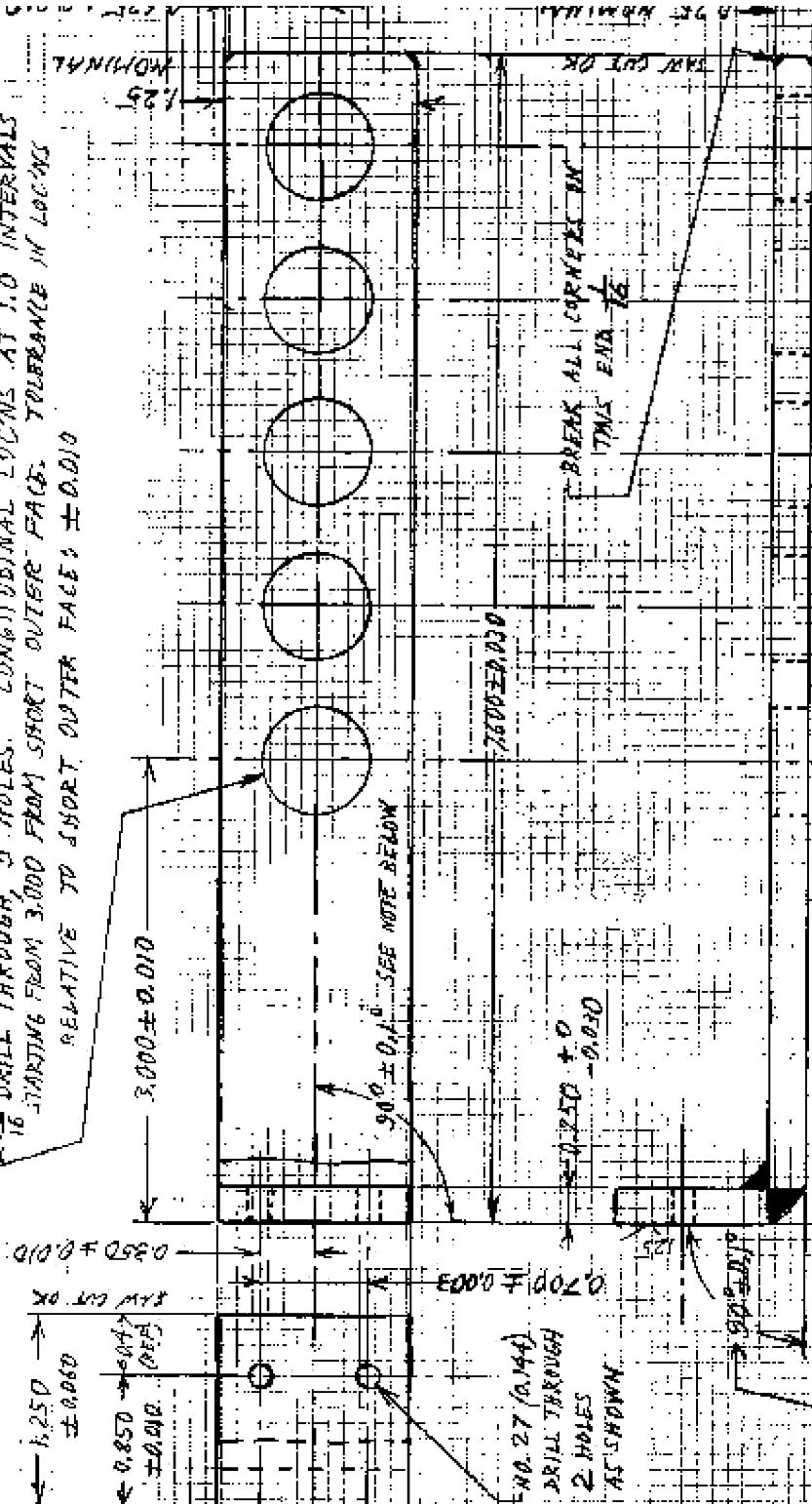

TO BE ATTAINED BY CLEANUP CUT ON SHORT OUTER FACE AFTER WELDING

MATERIAL: 1/4 X 1/4 ALUMINUM BAR 6061-T6511

MOUNT FOR ULTRASONIC SENSOR (MIGRATION), MODEL DRD-1
 INNOVATIVE MECHANICS, INC. 265 DE RD., CLAR MILLS IL 60514-102
 TEL/FAX (830) 887-3020 TEL 887-8478 A. PEEBLYA 2001-12-27

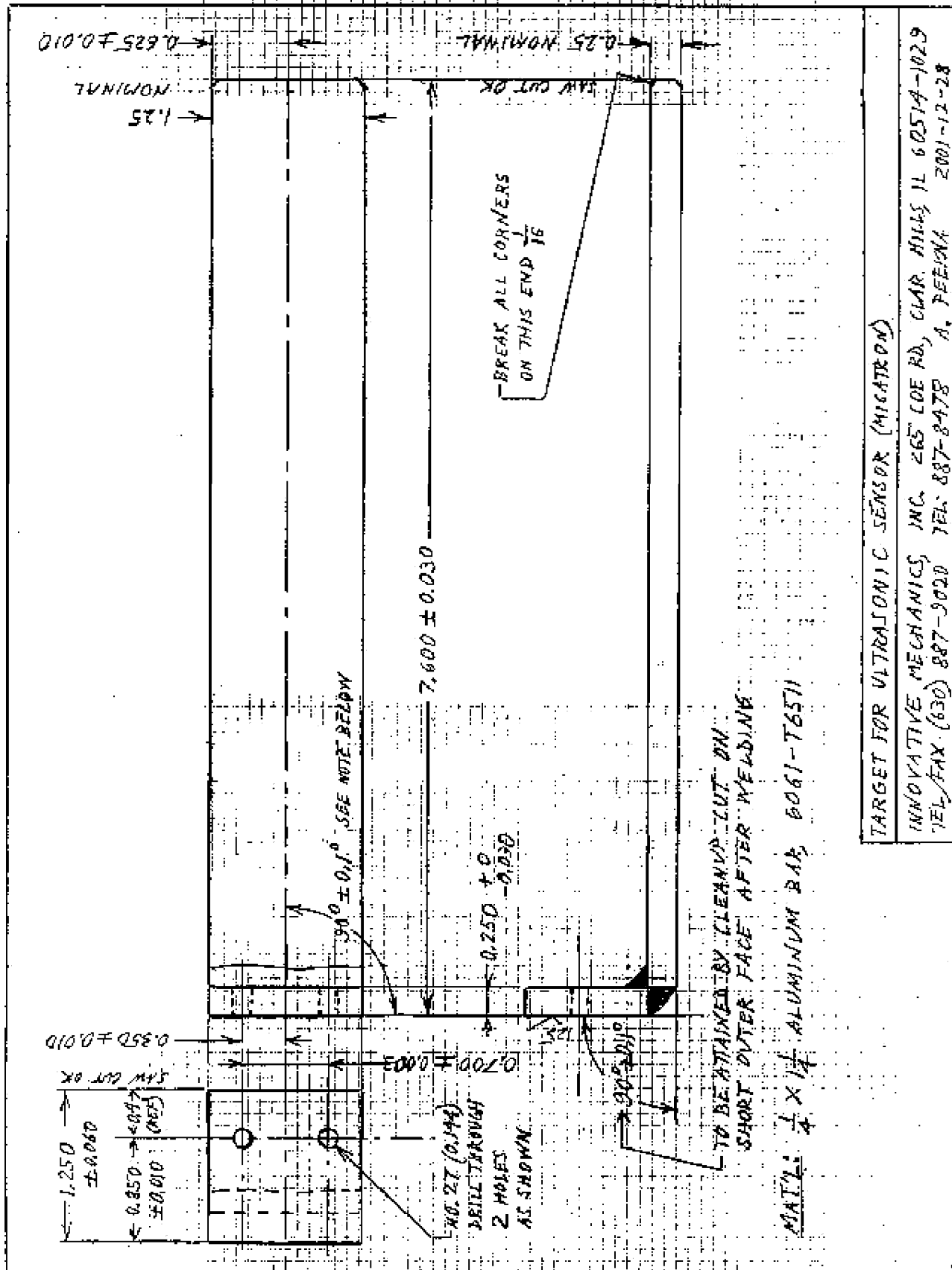

13 (REF)

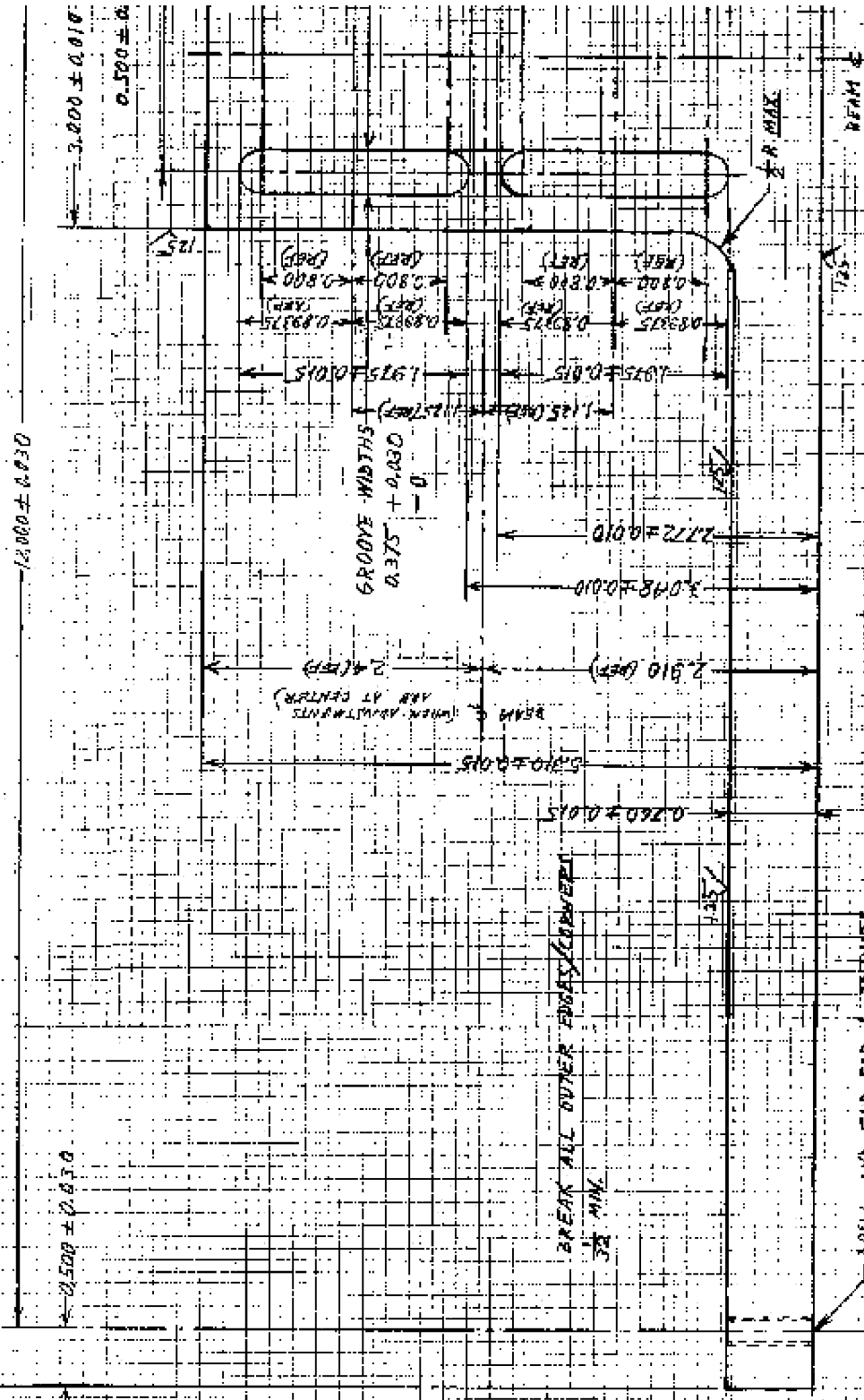

FORM 4
A.S.P.
CENT'D ON PLATE

SIMPLE SUPPORTS (NOT CANTILEVERED) FOR BEAM

INNOVATIVE MECHANICS, INC. 285 COE RD, CLAIR, ILLINOIS
TEL/FAX (630) 887-3028 887-8478 A. PLEBKA

DRILL AND TAP FOR 1/4 20 UNF X 0.125
CENTERED ON PLATE THICKNESS WITHIN 0.010

MATERIAL: 1/2 INCH THICK ALUMINUM PLATE
7075-T651

DRAWING IS TO SCALE ONLY IN PROPORTIONS

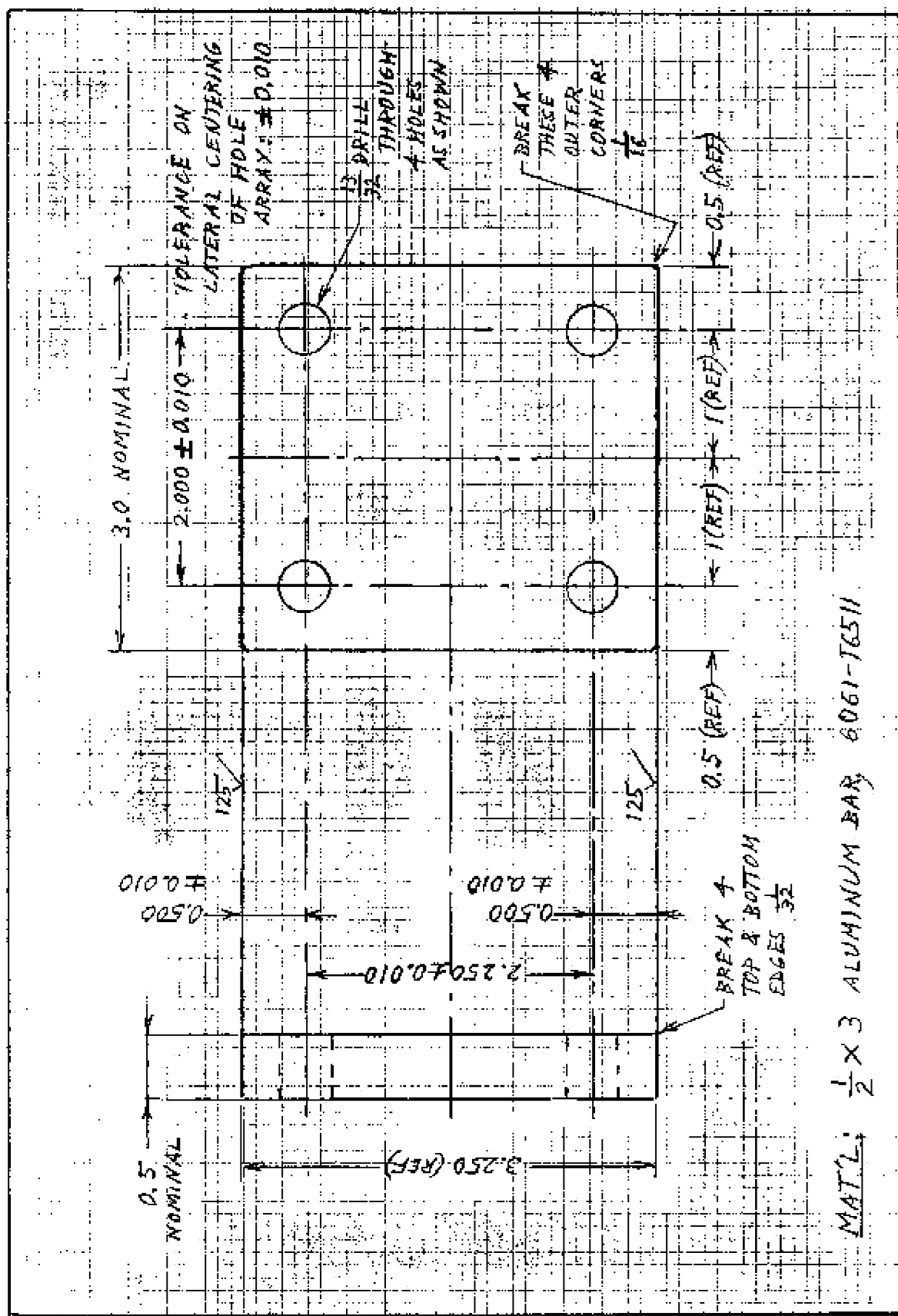

CLAMPING PLATE FOR END SUPPORTS

INNOVATIVE MECHANICS, INC. 265 COE RD, CLAR, HILLS, IL 60514-1029
 TEL/FAX (630) 887-9020 TEL: 887-8478 A. PEEMIA 2002-2-6

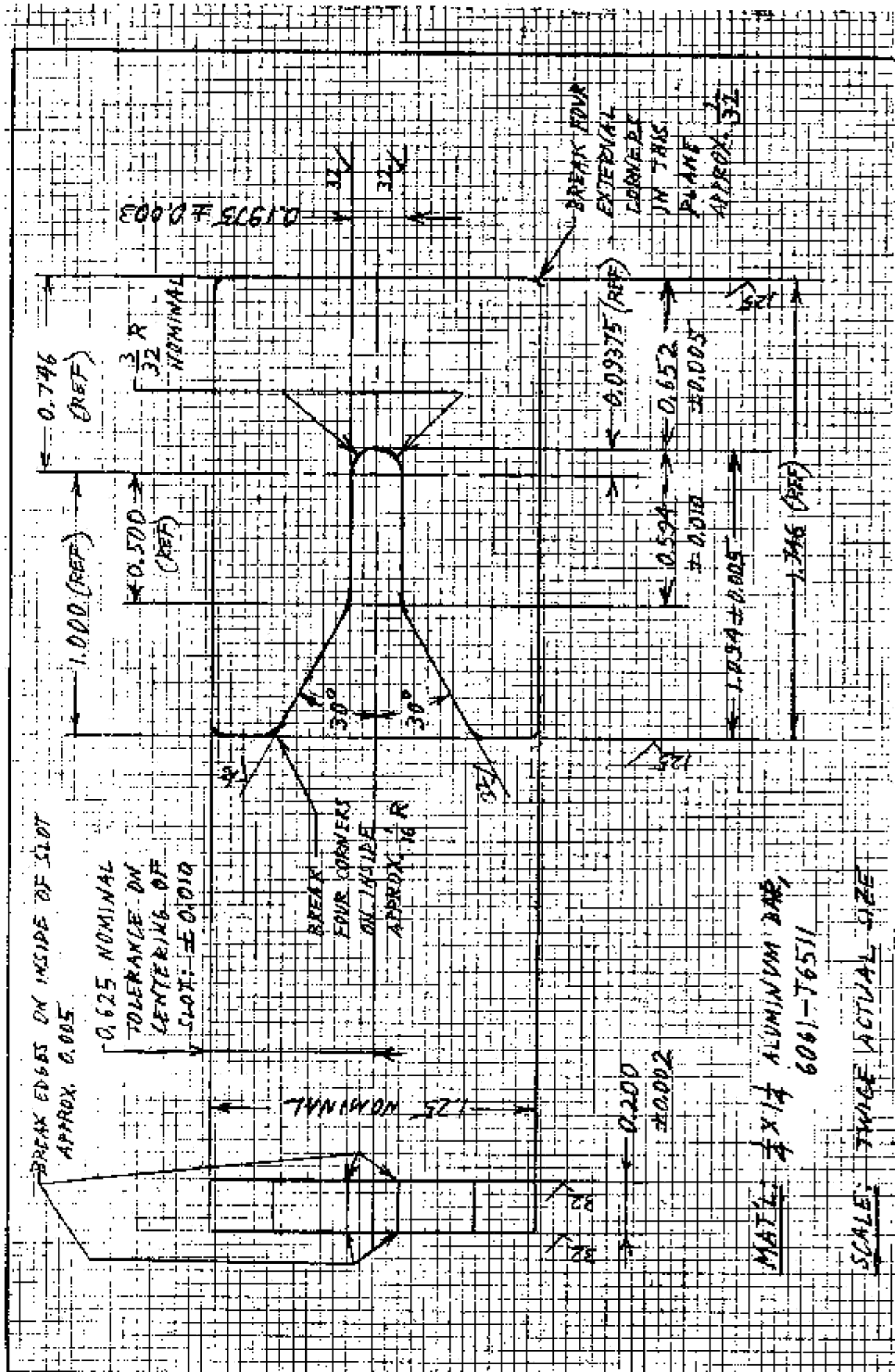

BREAK EDGES ON INSIDE OF SLOT APPROX 0.005

0.625 NOMINAL TOLERANCE ON CENTERING OF SLOT: ±0.010

BREAK FOUR CORNERS ON INSIDE APPROX 1/16 R

BREAK FOUR EXTERNAL CORNERS IN THIS PLANE APPROX 3/32

MATERIAL ALUMINUM BAR, 6061-T6511

SCALE: TWICE ACTUAL SIZE

SPACER FOR SETTING LYDT HEIGHTS ABOVE ROAD
 INNOVATIVE MECHANICS, INC. 265 COE RD, CLAR. HILLS, IL 60514-1029
 TEL/FAX (30) 887-9020 TEL 887-8478 A. PEENIA 2001-12-29