



**UNITED STATES AIR FORCE
RESEARCH LABORATORY**

**PCBoom3 Sonic Boom Prediction
Model – Version 1.0c**

Kenneth J. Plotkin

**WYLE RESEARCH LABORATORIES
2001 Jefferson Davis Highway
Arlington VA 22202**

May 1996

Interim Report for the Period August 1992 to May 1996

20020307 053

Approved for public release; distribution is unlimited.

Human Effectiveness Directorate
Crew System Interface Division
2610 Seventh Street
Wright-Patterson AFB OH 45433-7901

NOTICES

When US Government drawings, specifications, or other data are used for any purpose other than a definitely related Government procurement operation, the Government thereby incurs no responsibility nor any obligation whatsoever, and the fact that the Government may have formulated, furnished, or in any way supplied the said drawings, specifications, or other data, is not to be regarded by implication or otherwise, as in any manner licensing the holder or any other person or corporation, or conveying any rights or permission to manufacture, use, or sell any patented invention that may in any way be related thereto.

Please do not request copies of this report from the Air Force Research Laboratory. Additional copies may be purchased from:

National Technical Information Service
5285 Port Royal Road
Springfield, Virginia 22161

Federal Government agencies and their contractors registered with the Defense Technical Information Center should direct requests for copies of this report to:

Defense Technical Information Center
8725 John J. Kingman Road, Suite 0944
Ft. Belvoir, Virginia 22060-6218

DISCLAIMER

This Technical Report is published as received and has not been edited by the Air Force Research Laboratory, Human Effectiveness Directorate.

TECHNICAL REVIEW AND APPROVAL

AFRL-HE-WP-TR-2001-0155

This report has been reviewed by the Office of Public Affairs (PA) and is releasable to the National Technical Information Service (NTIS). At NTIS, it will be available to the general public.

This technical report has been reviewed and is approved for publication.

FOR THE COMMANDER



MARIS M. VIKMANIS
Chief, Crew System Interface Division
Air Force Research Laboratory

REPORT DOCUMENTATION PAGE

Form Approved
OMB No. 0704-0188

Public reporting burden for this collection of information is estimated to average 1 hour per response, including the time for reviewing instructions, searching existing data sources, gathering and maintaining the data needed, and completing and reviewing the collection of information. Send comments regarding this burden estimate or any other aspect of this collection of information, including suggestions for reducing this burden, to Washington Headquarters Services, Directorate for Information Operations and Reports, 1215 Jefferson Davis Highway, Suite 1204, Arlington, VA 22202-4302, and to the Office of Management and Budget, Paperwork Reduction Project (0704-0188), Washington, DC 20503.

1. AGENCY USE ONLY (Leave blank)		2. REPORT DATE May 1996	3. REPORT TYPE AND DATES COVERED Interim - Aug 1992 to May 1996	
4. TITLE AND SUBTITLE PCBoom3 Sonic Boom Prediction Model - Version 1.0c			5. FUNDING NUMBERS C - F33615-89-C-0574 PE - 63723F PR - 3037 TA - 303706 WU - 30370601	
6. AUTHOR(S) Kenneth J. Plotkin				
7. PERFORMING ORGANIZATION NAME(S) AND ADDRESS(ES) Wyle Laboratories 2001 Jefferson Davis Highway Arlington VA 22202			8. PERFORMING ORGANIZATION REPORT NUMBER WR 95-22	
9. SPONSORING/MONITORING AGENCY NAME(S) AND ADDRESS(ES) Air Force Research Laboratory, Human Effectiveness Directorate Crew System Interface Division Aural Displays and Bioacoustics Branch Air Force Materiel Command Wright-Patterson AFB OH 45433-7901			10. SPONSORING/MONITORING AGENCY REPORT NUMBER AFRL-HE-WP-TR-2001-0155	
11. SUPPLEMENTARY NOTES				
12a. DISTRIBUTION AVAILABILITY STATEMENT Approved for public release; distribution is unlimited.			12b. DISTRIBUTION CODE	
13. ABSTRACT (Maximum 200 words) PCBoom3 is a PC-based program that computes single-event sonic boom footprints from any supersonic vehicle exercising any maneuver in a real atmosphere, including winds. The user specifies the aircraft, the maneuver, and the atmosphere. The primary output is the sonic boom footprint in terms of contours of equal overpressure (or other amplitude metric) on the ground, relative to the aircraft's position. PCBoom3 also generates sonic boom signatures, the pressure-time history of the boom at a particular location on the ground. Spectra of these signatures are also computed. The program is operated through a menu interface, which simplifies its use and the presentation of results. The program is designed for use by personnel who are planning specific supersonic missions where sonic boom will be an issue or who are investigating sonic boom incidents. While the program is relatively simple to operate, it provides access to analysis which requires an understanding of sonic boom phenomena. A copy of this program can be obtained by contacting AFRL/HECB at (937) 255-3605 x423 or downloading the file directly from the public website at www.afcee.brooks.af.mil/EC/noise/noisemodels.htm .				
14. SUBJECT TERMS sonic boom, model, noise, acoustics			15. NUMBER OF PAGES 37	
			16. PRICE CODE	
17. SECURITY CLASSIFICATION OF REPORT UNCLASSIFIED	18. SECURITY CLASSIFICATION OF THIS PAGE UNCLASSIFIED	19. SECURITY CLASSIFICATION OF ABSTRACT UNCLASSIFIED	20. LIMITATION OF ABSTRACT UL	

This page intentionally left blank.

PREFACE

The PCBoom3 Sonic Boom Prediction Model was developed under Air Force contract F33615-89-C-0574. The work was conducted under Program Element 63723F, Workunit 30370601, under the direction of the Aural Displays and Bioacoustics Branch of the Air Force Research Laboratory, Wright-Patterson AFB OH. Robert A. Lee was the project monitor.

This page intentionally left blank.

TABLE OF CONTENTS

	<u>Page</u>
1.0 INTRODUCTION	1
2.0 SONIC BOOM	2
2.1 Overview	2
2.2 Wave and Ray Pattern.	4
2.3 Boom Analysis Via PCBoom3	7
3.0 OPERATING PCBoom3	13
3.1 Installation	13
3.2 Running PCBoom3: Main Menu	15
3.2.1 Main Menu Layout	15
3.2.2 Menu Choices	16
3.3 Running PCBoom3: Major Functions	18
3.3.1 Execute	18
3.3.2 Results	18
3.3.2.1 Plot Contours	19
3.3.2.2 Plot Signatures and Spectra	20
3.3.2.3 Examine Summary Table	21
3.3.3 Creating a Trajectory	22
3.3.4 Creating an Atmosphere	23
3.4 Specialized Inputs and Launch Vehicles.	24
3.4.1 Aircraft Parameters	24
3.4.2 Importing Trajectories	26
4.0 PROGRAM STRUCTURE	27
APPENDIX A: Files	A1
A.1 Files Used	A1
A.2 Internal File Structures	A2
A.2.1 Atmosphere File	A2
A.2.2 Trajectory File	A3
A.2.3 ASCII Contour File	A3
A.2.4 ASCII Signature and/or Spectrum File	A4

LIST OF FIGURES

<u>Fig.</u> <u>No.</u>		
1	Sonic Boom Generation, Propagation, and Signature Evolution	3
2	Sonic Boom Wave Field	3
3	Wave and Ray Viewpoints.	5
4	Sequence of Isopemps for Steady Level Flight	6
5	Sequence of Isopemps for Steady Supersonic Turn	6
6	Acceleration Focus: Three Dimensions	8
7	Sequence of Isopemps for Acceleration	9
8	Overpressure Contours for Acceleration Focal Zone	9
9	Focused and Unfocused Boom Signatures	10
10	Combined N-U Signature Near a Focus	11

1.0 INTRODUCTION

PCBoom3 is a PC-based program that computes single-event sonic boom footprints from any supersonic vehicle exercising any maneuver in a real atmosphere, including winds. The user specifies the aircraft, the maneuver, and the atmosphere. The primary output is the sonic boom footprint in terms of contours of equal overpressure (or other amplitude metric) on the ground, relative to the aircraft's position. PCBoom3 also generates sonic boom signatures, the pressure-time history of the boom at a particular location on the ground. Spectra of these signatures are also computed.

The program is operated through a menu interface, which simplifies its use and the presentation of results. The program is designed for use by personnel who are planning specific supersonic missions where sonic boom will be an issue, or who are investigating sonic boom incidents.

While the program is relatively simple to operate, it provides access to analysis which requires an understanding of sonic boom phenomena. Section 2 provides a review of sonic boom theory, with emphasis on the effects of maneuvers and atmospheric profiles. Section 3 is the user's manual. Section 4 contains a discussion of the structure of the program, its components, and capabilities.

This report is prepared in support of PCBoom3 Version 1.0c, which includes launch vehicle boom capability. This version is fully operational, but has menu choices for some features which will appear in later versions. A "not yet" (or similar) message will appear if unimplemented features are selected. Major new features of 1.0c are the ability to handle high altitudes associated with launch vehicles, inclusion of rocket plume effects, and the capability of importing trajectory/ maneuver data from external sources.

Several utility programs are also provided. Review the /DOCS directory on each disk for features added after preparation of this manual.

2.0 SONIC BOOM

2.1 Overview

An aircraft traveling at supersonic speed generates a disturbance in the form of shock waves. Figure 1 is a sketch of this disturbance. Near the aircraft, the shocks form a detailed pressure signature which relates to every detail of the aircraft's geometry. As this disturbance propagates away from the aircraft, its shape tends to stretch and distort towards a simpler "N-wave", with a bow shock associated with the front of the aircraft, a linear expansion to a negative pressure, then a second shock related to the recompression at the tail. This N-wave, sketched at the bottom of Figure 1, is heard at the ground as a sonic boom. The magnitude and duration of the boom depend on the size, shape, and weight of the aircraft, and its altitude and flight parameters. PCBoom3 contains tables of aircraft parameters for all current supersonic aircraft. For a given aircraft, the major factors affecting sonic boom are the flight altitude and maneuvering of the aircraft.

Figure 1 shows the sonic boom under an aircraft. The waves are shown curved so as to represent the distortion of the signature and also distortion due to sound speed gradients in the atmosphere. Sonic boom is generated to the sides as well, so that the waves shown in Figure 2 are a two-dimensional cut of a three-dimensional wave cone. Figure 2 is a sketch of the full sonic boom wave. (For simplicity, Figure 2 shows a pure cone, but actual boom waves are distorted by atmospheric gradients. This "straight wave, straight ray" simplification is retained in most of the illustrations.) Note that the boom "wave cone" intersects the ground in a hyperbolic pattern; N-waves are sketched at this intersection. This hyperbolic intersection line is sometimes called an "isolabe". The boom moves with the aircraft, and the shaded area on the ground to the rear represents areas which have experienced a boom. The area over which the isolabe sweeps the ground during a supersonic mission is often referred to as the "boom carpet". Because of gradients in the real atmosphere, the cone is usually distorted such that the isolabe does not extend indefinitely to either side, but stops at some lateral "cutoff" distance. The distance from left cutoff to right cutoff is referred to as the carpet width.

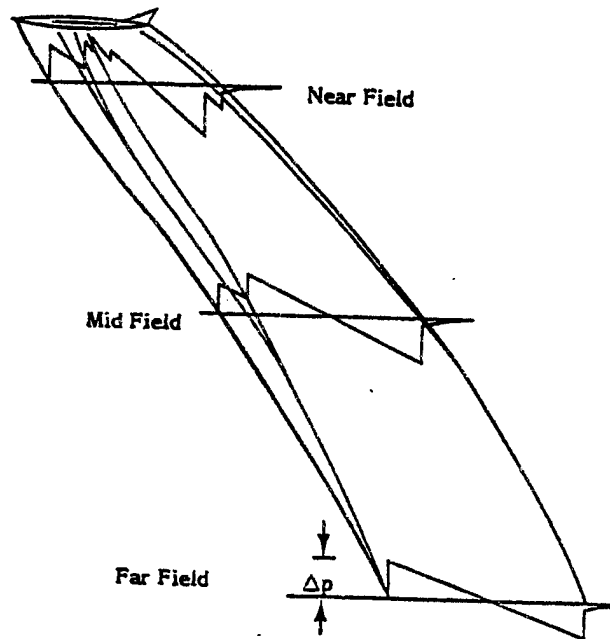

Figure 1. Sonic Boom Generation, Propagation, and Signature Evolution.

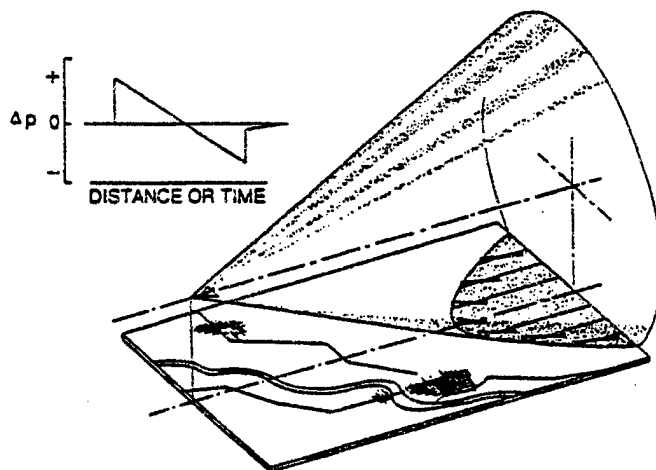

Figure 2. Sonic Boom Wave Field.

Aircraft Mach number has surprisingly little effect on the amplitude of the boom, but it does affect its ground location. The half angle of the wave cone is given by the Mach angle, which is inversely related to the Mach number. At high Mach numbers, the wave cone is very slender, trailing behind the aircraft, while it is broad at low supersonic Mach numbers.

2.2 Wave and Ray Patterns

Figures 1 and 2 present sonic boom from an aircraft-fixed viewpoint. This shows the aircraft and the wave pattern as they exist at a given time, and is a good viewpoint when considering steady flight. While the wave cone exists as shown at a given time, it is actually generated over a period of time and a maneuvering aircraft generates a distorted cone. When the aircraft is maneuvering, or when the boom is of interest at specific points on the ground, it is better to adopt a viewpoint fixed to the ground, and analyze the boom in terms of rays rather than wavefronts. Figure 3 shows sonic boom from both wave and ray viewpoints. The aircraft is flying towards the right (rather than to the left as in Figure 2), and the wave cone and isolabe are shown to the left. A ray cone is shown toward the right. The ray cone is perpendicular to the wave cone, and represents the path of sonic boom energy which is generated at a given time. The boom generated at time t in Figure 3 will propagate along rays and reach the ground some time later. The hyperbolic line where the ray cone intersects the ground is sometimes referred to as an "isopemp". The isopemp is always forward of the aircraft position at which the boom was generated. It is common to refer to this distance, measured along the flight path, as the "forward throw" of the boom. The ray cone is narrow at low Mach numbers (long forward throw) and broad at high Mach numbers (small forward throw).

It is important to recognize that once the aircraft generates the vertex of its Mach cone at a given time, the corresponding ray cone (and its ground impingement isopemp) is established, and is independent of subsequent maneuvers. The wave cone is made up of boom elements from a number of earlier ray cones. Figure 2 and the left side of Figure 3 are valid only if the aircraft has been flying at steady speed; had it been maneuvering the wave cones would be distorted.

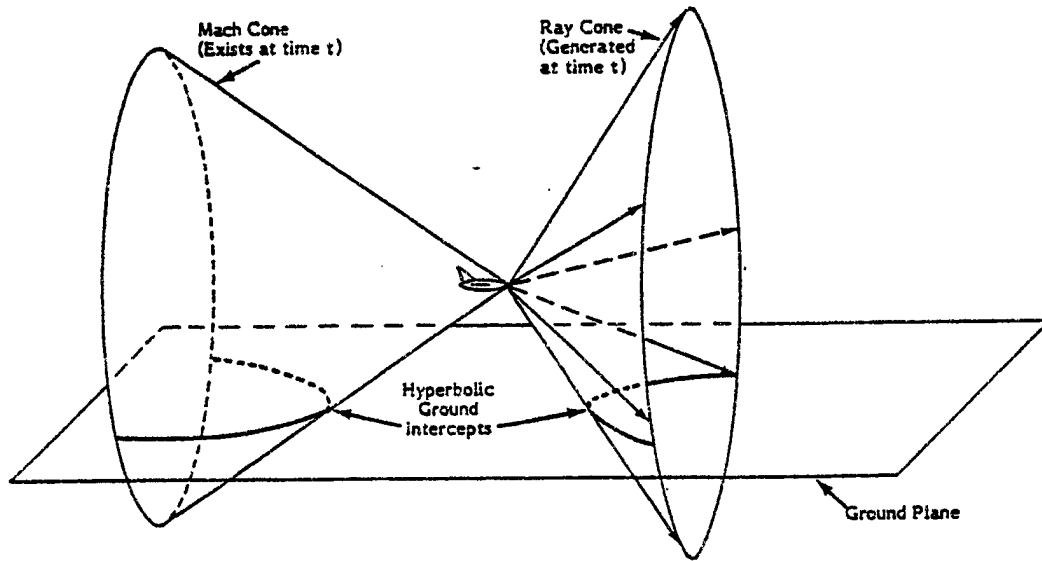

Figure 3. Wave and Ray Viewpoints.

If ray cones are computed at regular intervals for an aircraft in straight, level, steady flight, the isopemps will be a sequence of identical forward-facing hyperbolic curves along the flight track. This is illustrated in Figure 4, where isopemps are plotted at five-second intervals for steady level flight. In Figure 4, the aircraft is flying to the north. The flight track is the vertical line, and the first trajectory point analyzed is marked by a "+". If the aircraft makes a turn, then the isopemps will be laid out in a curved pattern. Because of the forward throw, the flight track will lie toward the inside of a curve connecting the centers of the isopemps. If the turn is sharp enough, the flight track can even have a smaller radius than a line connecting the cutoff edges of the isopemps. This is illustrated in Figure 5 for a segment of a turn. The aircraft is initially headed north (beginning of trajectory marked by a "+") and turns to the right.

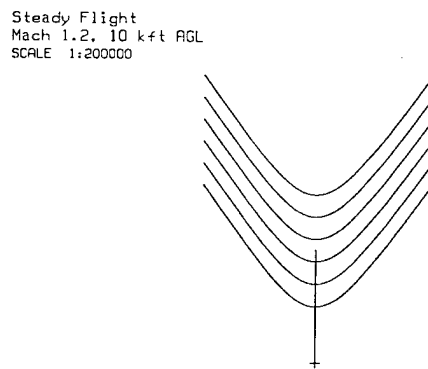

Figure 4. Sequence of Isopemps for Steady Level Flight.

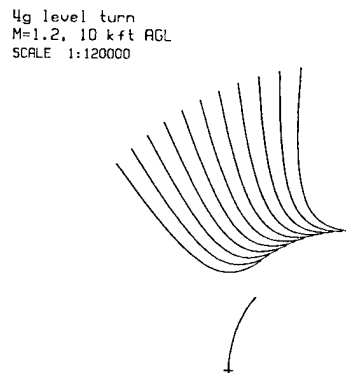

Figure 5. Sequence of Isopemps for Steady Supersonic Turn.

In Figure 5, the isopemps are overlapping toward the inside. This overlapping represents a focused "superboom", which is more easily illustrated for the case of an accelerating aircraft. Figure 6 shows ray cones at two successive times for an accelerating aircraft. The acceleration causes a broadening of the ray cones and consequent reduction in forward throw. As sketched in Figure 6, the isopemps intersect at points off to the side. (At an earlier time, the isopemps intersected along the centerline.) When isopemps cross, their intersection represents a position where boom energy is concentrated, or focused, and a "superboom" exists. Figure 7 shows the isopemp pattern for an F-16 accelerating at 0.28 g at 10,000 feet altitude, flight direction to the east. The boom carpet is in the area covered by the isopemps. Note the isopemps crossing at the crescent-shaped boundary of the carpet. This edge is a focal zone. Figure 8 shows contours of overpressure corresponding to this same maneuver. The pressures in the focal zone (located at left edge of the contours, and too narrow to distinguish detail at this scale) are several times higher than farther along the track. Focus booms are also distorted, having a spiked "U-wave" shape rather than an N-wave. This is sketched in Figure 9. Locations near a focus can have combinations of N and U waves, as shown in Figure 10.

2.3 Boom Analysis Via PCBoom3

PCBoom3 is designed to analyze sonic booms from single sorties, with emphasis on identifying the specific pattern and amplitude of the footprint. The user specifies three major inputs:

- The aircraft. This affects the overall magnitude of the boom. When a new aircraft is being developed, this aspect can be of great interest, particularly if there are special considerations for the boom it will produce. Current supersonic aircraft virtually always produce normal N-waves, and in typical application of PCBoom3 by planners it is important to specify the proper aircraft, but there is nothing of great interest beyond that.
- The atmosphere. PCBoom3 uses this to account for the effect of temperature gradients and winds on the boom location. This is important when the precise location of the boom footprint is needed, such as in the planning of flight tests or when specific sensitive receptors are an issue. It is common for operators of off-shore supersonic areas to need this information to establish how far out the aircraft must go to avoid impacting on-shore locations.

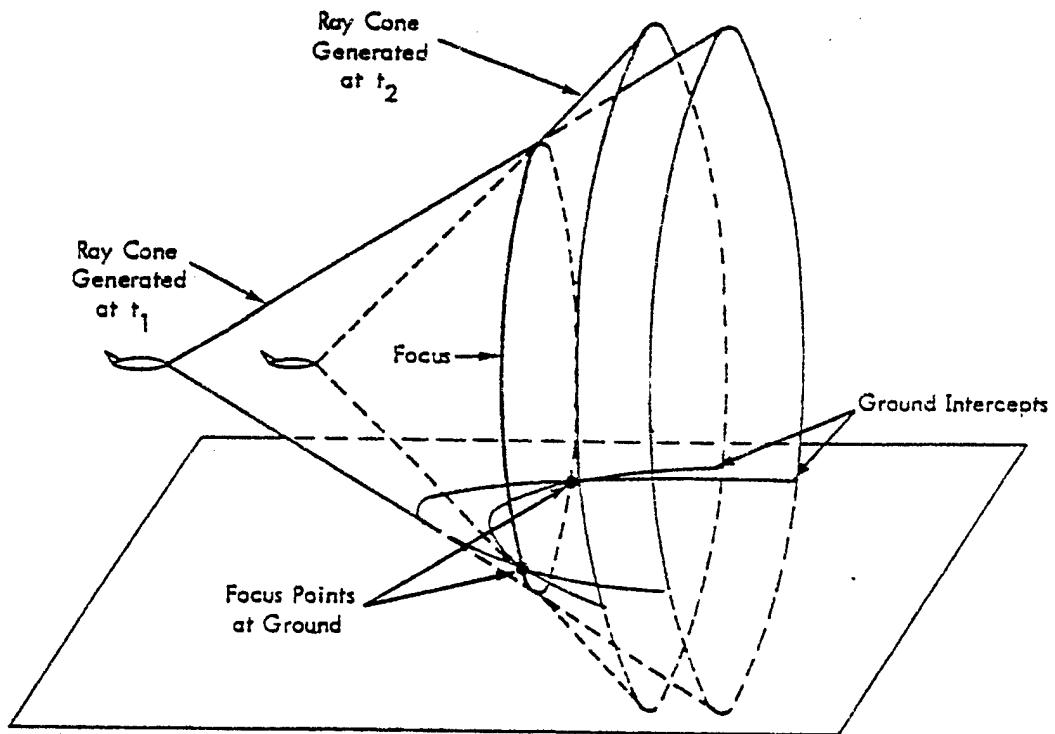

Figure 6. Acceleration Focus: Three Dimensions.

0.28 g level accel, 10kft MSL
EAFB standard atmosphere
Ground at 2800 feet MSL
SCALE 1:250000

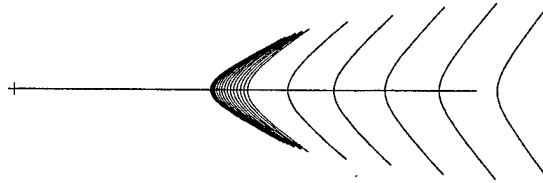
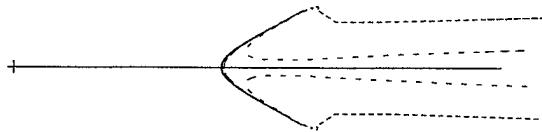

Figure 7. Sequence of Isopemps for Acceleration. Isopemps are initially at 1-second intervals, then transition to 10-second intervals.

0.28 g level accel, 10kft MSL
EAFB standard atmosphere
Ground at 2800 feet MSL
SCALE 1:250000



----- 4.0 psf
----- 6.0 psf
----- 8.0 psf
----- 10. psf
----- 12. psf
----- 14. psf

Figure 8. Overpressure Contours for Acceleration Focal Zone.

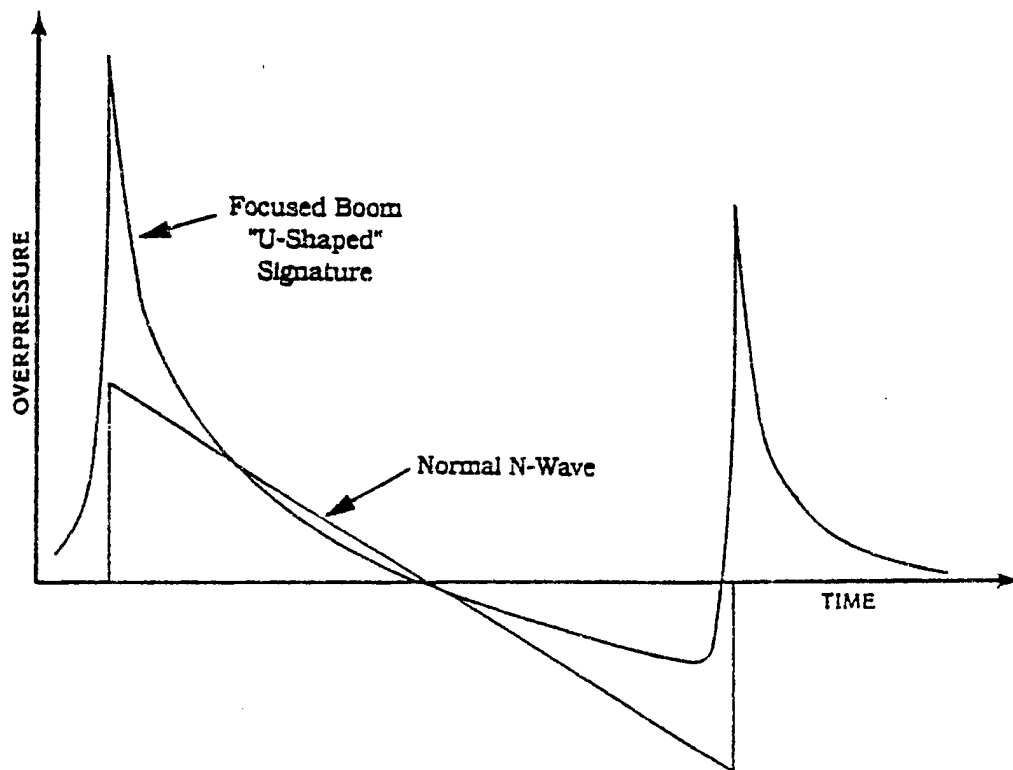

Figure 9. Focused and Unfocused Boom Signatures.

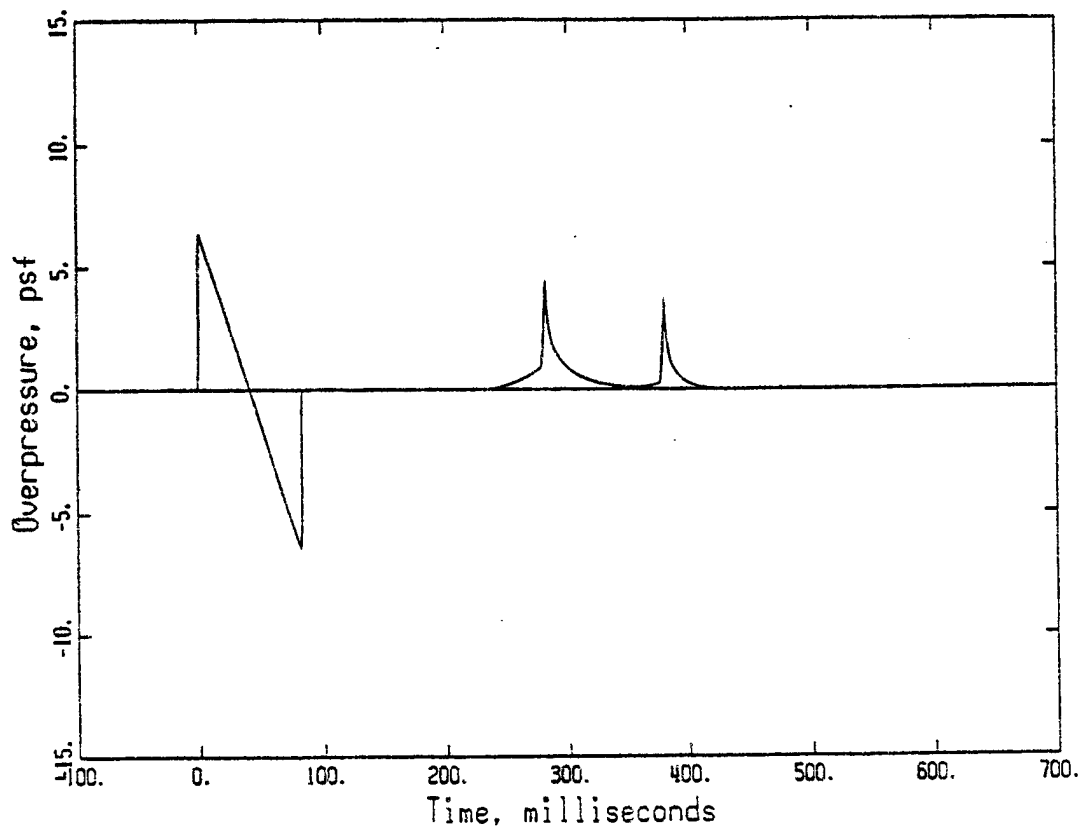

Figure 10. Combined N-U Signature Near a Focus.

- The aircraft maneuver. This is usually the most important input, with PCBoom3 typically being run to predict the boom associated with a maneuver. Currently, the maneuver can be input into PCBoom3 in two ways. The first is to load a data file which has been previously prepared. The second way is to define a maneuver by specifying the initial position and flight parameters, followed by a sequence of times and rate changes. A future version of PCBoom3 will have a general maneuver input mode, where a user can interactively specify what the aircraft is doing, where it winds up, etc.

PCBoom3's primary outputs are two graphical representations of the boom footprint. The first is contour plots of peak overpressure, as shown in Figure 8, or contour plots of five other amplitude/loudness metrics. This result is directly usable in environmental assessment of the proposed maneuver. The second is plots of the isopemps, as shown in Figures 4, 5, and 7. These are very useful in understanding the area which will receive boom and in analyzing the occurrence of any focal zones. Both types of plot include the ground track of the aircraft. The program can put both on the same plot if desired. The user can also place markers at specific trajectory points, with the corresponding isopemps also being marked. This helps visualize the ray cones and the forward throw of the boom. PCBoom3 always draws x,y axes at the first trajectory point, to identify the start of the maneuver.

PCBoom3 also generates plots of the boom signature and/or its spectrum. Figure 10 is a typical signature plot. The user can request signatures at the end of a particular ray, or at a specific ground location within the footprint. Spectrum output can be either energy spectral density or the residual shock spectrum.

3.0 OPERATING PCBoom3

3.1 Installation

PCBoom3 operates on an MS-DOS-based personal computer. An 80386 or faster is recommended, and a math coprocessor is highly recommended. There must be at least 540 kB of available low-DOS program memory.* A hard drive is necessary. PCBoom3 is a set of several programs and batch files, none of which is actually named PCBoom3. The programs occupy less than 1 MB of disk space, but data files generated (both output and temporary) can be large. At least 10 MB of free disk space is recommended. Unpredictable results can occur if disk space is exceeded, particularly when plotting.

The software is supplied on a single floppy disk. Everything needed to install and run it is in the root directory. There is a file README.1ST which contains updates (if any) to this manual. There is also a directory DOCS which contains text files with further documentation, and a directory DATA which contains sample data files, including several atmosphere files. A separate developer's disk contains subdirectories with source code for the programs.

Installation consists of the following steps:

1. Create a directory for the programs, using the DOS command MD.
2. Copy all files from the root of the distribution disk into this directory.
3. Edit the PATH command in your AUTOEXEC.BAT to include the new program directory.
4. Create a data directory, and copy desired example files from the DATA directory of the installation disk.
5. Reboot your computer to activate the revised PATH.

To run the program, change directories to the current working directory, then enter PCB. This will bring up the main menu, described in Section 3.2.

The first time you run PCBoom3, you should enter your personal registration data, via menu Status/Registration. This will create file PCB3.INI in the current working directory. This file should be copied to any other working data directories.

* A supplementary disk "32 Bit XM Executables" contains extended memory versions of several modules. These are not limited by low memory, and can handle larger cases. See documentation on that disk for instructions.

The program is structured so that all data files for a given case are contained in a single directory. This does entail some replication of files (PCB3.INI, standard atmosphere files) if several data directories are used, but greatly simplifies archiving and auditing particular cases.

There are three variations on installation:

1. Data files can be placed in the program directory, and that will be the active directory when running the program. That eliminates the need for changing the PATH variable.
2. SET commands, rather than PATH, can be used in the setup. This allows the program modules to be placed in separate directories. This is a complex procedure, not normally needed, and is described in a DOC file on the disk.
3. While not recommended, the program can be run under Windows 3.1. To do this, first perform the DOS installation, then run Windows and use Program Manager to create a PCBoom3 program item, with the command line PCB.BAT. The working directory should be the one in which you installed PCBoom3. An icon, PCBOOM3.ICO, is included with the software.

PCBoom3 will run under Windows 95 provided Windows 95 is booted into MS-DOS mode (from the GUI select Start . . . Shut down . . . MS-DOS mode). Follow the normal DOS installation, items 1 or 2, above. Because of compatibility deficiencies in Windows 95, operation of PCBoom3 under the GUI mode (i.e., by selecting the MS-DOS icon) is problematical.

If a Microsoft-compatible mouse is present, it will be active in the main menu and submenus. To disable the mouse, invoke PCBoom3 with the command PCB /n.

It is assumed that the computer has a program called LIST which displays ASCII files. There are a number of such programs available, either as freeware or shareware. Alternatively, the DOS editor can be used for this purpose by creating a batch file named LIST.BAT with the following line:

```
edit %1
```

It is also assumed that the system has the DOS editor, or another ASCII editor named EDIT, available. For any other editor not called EDIT, enter the following command before running PCBoom3:

```
set pcedit = myeditor
```

where "myeditor" is the name of the editor. If this editor is invoked via a batch file, use the command

```
set pcedit = call editbat
```

where "editbat" is the name of the batch file. "Myeditor" or "editbat" must be available in the path, and must accept the name of the file on the command line.

3.2 Running PCBoom3: Main Menu

3.2.1 Main Menu Layout

Once installed, run the software by typing PCB at the DOS prompt, or double clicking on the icon in Windows. This will bring up the main screen, which is blank except for:

- A title line at the top
- A menu bar on the second line
- A status/information line at the bottom.

Menus are selected and activated by customary operation of the cursor keys, capitalized hot keys, and the enter and escape keys. The current choice is highlighted, and the status/information line always provides an explanatory phrase. There are three tiers of menus:

- The black menu bar near the top of the screen. One letter of each choice is a capitalized hot key; pressing that key opens a blue pull-down menu. Pressing Enter pulls down whichever choice is highlighted.
- Blue pull-down menus associated with each menu bar. When one of these is down, capitalized hot keys for that menu are active, or Enter activates the highlighted choice.
- Grey action items/menus. Selecting an item from a blue pull-down menu may cause an immediate action, or bring up a grey action box. Some action boxes are dialogs which require an entry. Some are lists from

which a choice must be made. To choose an item from a grey list, highlight the desired one by using the cursor keys, then press Enter.

The basic goal in the main menu screen is to create a case by selecting an aircraft, an atmosphere, the ground altitude, a trajectory, and a title. Once these are selected, the case is saved via menu choice File/Save, then executed via menu choice File/Execute. Following execution, graphical or tabular output can be displayed. A case which has already been run can be re-loaded and output displayed again, or it can be modified, saved, and re-run.

The program is terminated by selecting Quit from the File menu, or by pressing either Control-Q or Control-X at any time that a grey action box is not displayed.

3.2.2 Menu Choices

There are six main menus, each of which has from 2 to 5 action choices. The menus and choices (as they appear on the screen) are:

File – controls major program actions and case load/save

Load case – load an existing case from a list of files.

Save case – save the current case. A name is requested via a dialog box. If complete information for a case has not yet been entered, this selection will say what is missing and where to enter it. The case must be saved for selected components to take effect.

Execute – brings up an action list to run the boom calculation. The two choices are described in Section 3.3.

Results – brings up an action list to display results, after executing a case. The three choices are described in Section 3.3.

Quit – ends the program. Anything not saved will be lost.

aTmosphere – defines the atmospheric conditions.

select File – load an existing atmosphere file.

create New – create a new file, using user-supplied data. This process is described in Section 3.3.

Edit old – edit an existing file.

Ground alt – specify the altitude (MSL) of the local ground, which can be different from the ground altitude in the atmosphere definition file.

Aircraft - specifies the aircraft

from List - select the desired aircraft from a grey list of available types. See Section 3.4 for a discussion of adjusting default parameters, and specifying launch vehicles.

F-function - select an aircraft description in F-function format from a list of available files. This is a specialized format related to aircraft design, and is not normally of interest to planners.

Maneuver - specifies the aircraft's trajectory

select File - select a maneuver from a list of existing files. See Section 3.4 for a discussion of importing trajectories from other sources.

Mand - create or edit a maneuver via the general maneuver driver. (Not yet implemented.)

new foBoom - enters a module in which the flight trajectory is specified. Details are described in Section 3.3. This module creates a file directly in FOBOOM3 format.

Edit old - directly edit an existing FOBOOM3 format maneuver file.

Targets - enter coordinates of "targets" or "witness marks" to appear on the contour plot.

Configure - set configuration parameters for case and program

case Title - enter a title for the current case.

Plot devices - specify output devices. A list of codes is provided in the file PLOT88.DEV.

Expert stuff - allows modification of certain numeric parameters in the program. These should be adjusted only by specialists knowledgeable in FOBOOM3's calculation methods.

Status - displays system information

Current case - summarizes the entries that have been made in support of the current case. If there are any blanks, it is likely that not enough information has been entered.

Memory test - proper memory function being essential to any complex analysis, this tests your random memory.

Registration - displays the name of the registered user of this copy of PCBoom3, or (if not registered) allows entry of registration data.

About - displays program version and author.

3.3 Running PCBoom3: Major Functions

Several of the menu choices described in Section 3.2 lead to major actions, or require further explanation. These are described below.

3.3.1 Execute

Selecting File-Execute brings up a grey list with the following choices:

- Execute Full Ray Trace Analysis
- Execute Simple Boom Analysis

The first of these causes the main sonic boom calculation, program FOBOOM3, to execute. This can take several minutes. While this is running, progress information is displayed. A message is displayed each time boom calculations begin at a new trajectory time. This is followed by a series of periods or asterisks, one each time a new ray calculation begins at that time. A period denotes that a normal boom has occurred. An asterisk denotes that a focus condition has occurred. (Some focus conditions cause the boom not to reach the ground, so not every asterisk means that a superboom has occurred.)

Following completion of the boom calculation, the boom footprint is processed to make it ready for contour and signature output. A message is shown, and a series of symbols appears to record progress. During this contour/signature processing, “ . ” denotes carpet boom at the ground, “ * ” denotes focus boom at the ground, and “ o ” denotes post-focus boom at the ground.

The second choice, "Execute Simple Boom Analysis", is not yet implemented. When installed, it will invoke a fast boom computation procedure valid for flight altitudes below 60,000 feet MSL and windless atmospheres.

3.3.2 Results

Selecting File-Results brings up a grey list with the following choices:

- Plot Footprint Contours
- Plot Signatures and Spectra
- Examine Summary Table

The first choice causes the program to run the plot module PCBPlot. The second choice allows plotting of individual boom signatures and spectra. The third choice allows review of a simple tabular output of the boom. These three choices are described in the following subsections.

3.3.2.1 Plot Contours

This choice invokes PCBPlot, which creates annotated plots of boom contours and/or isopemps. Figures 4, 5, 7, and 8 were generated by this module. When invoked, PCBPlot presents a series of five menus and dialog boxes which establish plot parameters. Once a case has been plotted, most of the selections are saved and used as defaults the next time.

The entry screens in the plot module, in the order they are encountered, are:

1. Main title entry. A title block is entered or edited in a 5-line by 60-character space. Press F10 to advance when done.
2. Arrange the plot layout on a preview screen. A schematic sketch of the plot is presented in the lower left quadrant of the screen. The following details can be adjusted:
 - The area occupied by the contours/isopemps/trajectory is indicated by a cluster of squares. The location and size are modified by using the cursor keys to adjust the position and page up/down are used to zoom out/in. Numeric values of the location offset and the scale factor are displayed in the lower right corner, and can be accessed for direct entry via the Tab key.
 - The areas occupied by the title block (as seen in the upper left of Figures 7 and 8) and a contour value legend (as seen in the lower left of Figure 8) are indicated by shaded areas. These may be moved via Control-arrow and Alt-arrow, respectively.
 - The page size may be adjusted by pressing keys A through E. Results are unpredictable if the plot device does not support the selected page size. All page sizes are scaled to fit when displayed on the screen.

These instructions are summarized on the screen. Press F10 when done.

3. Select specific data to plot. This screen will ask which contour metric to plot. There are six choices: peak pressure, CSEL, peak level, loudness, ASEL, and overall SPL. Selection "C to change caption or layout" will revert to Screen 1. Selection "Q Quit (return to main menu)" will terminate PCBPlot and return to the main menu screen. After selecting the metric, additional dialog will appear asking whether contours, isopemps, or both, are desired. Entering a choice for this (and pressing Enter) advances to the next screen. Choice 5, "Both together, plus ASCII file output", will have the same effect as 3, "Both together", but will also create an ASCII file containing the contours and trajectory. This file is described in Appendix A.
4. Select/Confirm Contour levels. Up to six contours can be plotted, and the values are entered here. Appropriate values must be entered for each metric to be plotted. This screen displays the maximum and minimum computed boom values. Instructions are on the screen. Press F10 to proceed.
5. Select plot device. A list of six plot devices is presented. There is also a Quit choice (returns to main menu) and a "Change plot" choice, which reverts control to Screen 3.

After a selection is made in Screen 5, the plot is drawn. If a file output was selected (e.g., Postscript or DXF to a file) then a dialog screen will appear asking for the file name. When the plot is complete, control reverts to Screen 5. It is typical to first display the plot on the screen, and if the result is satisfactory to immediately plot it to a hard copy device.

3.3.2.2 Plot Signatures and Spectra

This choice invokes SIG, which selects a signature for plotting, and PLT, which plots it. The desired plot is selected via a sequence of four screens:

1. A scrolling list of aircraft trajectory points, giving the aircraft time, Mach number, position, and altitude. Selecting one of these points will allow selection of a boom signature at the end of one of the computed rays. The last item on the list (reached by scrolling down or pressing "End") is "Enter Specific Coordinates". This choice allows plotting of the boom at any arbitrary location in the footprint.

2. If one of the trajectory points is selected, then a list is presented summarizing the boom computed for each ϕ at that time. The list shows ϕ , the ground intercept points x_g, y_g , the arrival time t_g of the boom at the ground, the maximum overpressure in psf, and the type of boom.

If "Enter Specific Coordinates" was chosen, then a dialog appears requesting the desired coordinates.

3. A selection box for the type of plot desired: signature, spectrum, or residual shock spectrum. The signature is overpressure (psf) versus time (milliseconds). Spectrum is the energy spectral density. Residual shock spectrum, normalized by peak pressure, gives an estimate of the dynamic amplification factor of a structure at its resonant frequencies. (Dynamic amplification factor is the ratio of maximum post-impulse response to static response.)
4. Output selection. The plot may be directed to any of the output devices. Tabular output may also be sent to a file. The file format is described in Appendix A.

Within each screen, ESC will generally revert to the prior screen. ESC from Screen 1, or Quit (when presented), will return to the main menu.

There is an important difference, in Screen 1, between selecting a trajectory time or specific coordinates. Selecting trajectory time will yield the signature at the end of a ray defined by aircraft time t and azimuth ϕ . The ground location x_g, y_g is a dependent variable. Selecting specific coordinates, on the other hand, makes ground location x_g, y_g the independent variable. In a complex region near a focus, the signature can be comprised of booms from several rays, and specific point mode will yield the complete signature. In particular, specific point analysis near a focus will yield combined N-U signatures as they occur.

3.3.2.3 Examine Summary Table

If this is selected, then a tabular summary of the boom calculation is displayed, and may be scrolled up/down via the edit keys. The file is a columnar table giving, for each aircraft time analyzed, the aircraft position and the boom position and amplitude at the centerline and at the location of the maximum boom on that isopemp.

3.3.3 Creating a Trajectory

Selecting Maneuver/new foBoom executes a dialog where a new trajectory file can be created. This file, once created, will be adopted for the current case and will also be saved, so that it will appear on subsequent selections of Maneuver/select File. The trajectory module will request the following data:

- The name of the trajectory, up to eight characters. This name, plus the extension .TRJ, will form the file name under which it is saved. Do not include any other extension in the name.
- A descriptive title line
- Flight parameters at the aircraft's initial location:
 - Mach number
 - Time
 - Flight altitude, feet MSL
 - X, Y location (X = east, Y = north)
 - Heading angle, degrees clockwise from north
 - Climb angle, degrees up from horizontal
 - First and second time derivatives of the Mach number, heading angle, and climb angle.
- A sequence of "Advance time" specifications. The trajectory is projected forward by this time, using constant values of the second derivative, and the boom computed at this new position. There is an option to change the second derivatives with each advance time specification. Entering a 0 advance time completes the file.

This trajectory format defines the maneuver as a series of tangent quadratic curves. This is an idealized approximation of how aircraft fly, with the second derivatives approximating force inputs at the controls. If actual trajectory data are available (usually the case for launch vehicles, and often the case for flight tests), these can be imported via the utility program TRAJ2TRJ, which is described in Section 3.4.

3.3.4 Creating an Atmosphere

Selecting aTmosphere/create New executes a dialog where a new atmosphere file can be created. This file, once created, will be adopted for the current case and will also be saved, so that it will appear on subsequent selections of aTmosphere/select File. The atmosphere will request the following data:

- Units for altitude inputs: F for kilofeet, M for kilometers.
- Units for temperature inputs: F, R, C, K for Fahrenheit, Rankine, centigrade, or Kelvin, respectively.
- Number of temperatures to be input. At least 2, and no more than 99.
- Altitude (MSL) and temperature. The first altitude is at the ground, and subsequent altitudes must be sequentially higher.
- Ambient pressure at the ground, psf. The ground is the altitude of the first temperature entered.
- Wind units: F for feet per second, M for meters per second. Enter X for no winds.

If X was not entered for winds, the dialog will continue:

- Number of X-wind values. Either 0 for no X-winds, or 2 to 99.
- Altitude and wind values for X-winds.
- Similar dialog for Y winds.

All altitudes entered are MSL. Winds have a sign corresponding to wind vector, i.e., the direction in which the wind is blowing, rather than the meteorological sense of the direction from which it is coming.

The alphabetic parameters for unit selection may be entered in either upper or lower case.

The file will be written in units of kilofeet, degrees Fahrenheit, and feet/second. The file structure is described in detail in Appendix A.

3.4 Specialized Inputs and Launch Vehicles

Two key inputs to PCBoom3 are the aircraft and the maneuver. The following sections provide detail on customizing these inputs. This information is of particular interest for launch vehicles.

3.4.1 Aircraft Parameters

The standard method of specifying an aircraft (Aircraft ... from list) invokes a simplified procedure developed by H.W. Carlson, "Simplified Sonic Boom Prediction", NASA Technical Paper 1122, 1978. That procedure defines the sonic boom source characteristics of an aircraft, in terms of an effective N-wave, by three parameters: its type ("shape factor" curve), length, and weight. Selection of an aircraft from the list brings up particular values of these three parameters. The user can change the weight, which is a common requirement to adjust for fuel load. Changing the weight in a particular case does not affect the default value for that aircraft.

If a user-defined aircraft is selected (last item on the list), the user can choose the shape factor curve, the length, and the weight. The following list of shape factors is presented:

1. Large fighter
2. Small fighter
3. Medium bomber
4. Large bomber
5. Fixed-wing fighter
6. Variable sweep airplane
7. Supersonic transport
8. Blunt lifting body
9. Launch Vehicle 1
10. Launch Vehicle 2
11. Launch Vehicle 3
12. Launch Vehicle 4
13. Launch Vehicle 5
14. Launch Vehicle 6
15. Launch Vehicle 7
16. Launch Vehicle 8

The list in PCBoom3 is not numbered; numbers are added here for reference. The names of 1 through 8 are the names in Carlson's report, and one selects a type which most closely resembles the new aircraft type being defined. After selecting the type, length (feet) and weight (kilopounds) are entered in appropriate dialog boxes.

Launch vehicles have a special consideration that, besides the boom generated by the vehicle itself, the exhaust plume will generate additional boom at high altitudes. The "Launch Vehicle" types account for these two components:

- The contribution of the vehicle itself is obtained by borrowing one of the standard aircraft shape factors, according to the above list. Launch Vehicle 8, for example, uses the "Blunt Lifting Body" factor. A vehicle such as the Titan, with strap-on boosters, should use Launch Vehicle 5, which borrows the "Fixed-wing fighter" shape factor. A more slender launch vehicle (such as Titan Stage 1, after the strap-ons are jettisoned) should use a more slender factor, such as Launch Vehicle 7 (Supersonic transport vehicle shape) or Launch Vehicle 2 (Small fighter shape). Length should be the vehicle's length. Weight should be the weight during the portion of flight when the boom reaches the ground, but this is not really important because there is negligible lateral g-loading during boost phase, hence no lift boom.
- The plume effect is defined by two additional parameters: thrust and plume drag. Thrust is the total vacuum thrust of all engines. Plume drag is the difference between the vacuum thrust that would exist if the nozzle had an infinite expansion ratio, and that for the actual nozzle expansion ratio. The ratio $(T+D)/T$, where T is thrust and D is plume drag, corresponds to V_{∞}/V_e , where V_e is the actual vacuum exhaust velocity and V_{∞} is the infinite-expansion exhaust velocity. Both are in kilopounds, and the dialogs for launch vehicle types include input and/or modification of these values. PCBoom3 uses the thrust and drag parameters to compute an effective N-wave source for the plume. This signature is a good approximation in the forward (positive pressure) region.

The total source for a launch vehicle with plume is a combination of these two portions. Predicted booms at the ground are approximately N-waves. The forward portion is generally reasonable, but actual plume-induced booms tend to have

smaller rear shocks than predicted by this method. The predicted maximum overpressures and loudness metrics are dominated by the forward portion of the signature, however, so this approximation is reasonable for most applications. Rear shocks for high-altitude flight are, in general, difficult to predict accurately.

3.4.2 Importing Trajectories

Accurate representation of flight trajectories often requires detailed analysis beyond the capability of the simple "FOBOOM3" format described in Section 3.3.3 or the "Mand" maneuver driver which is currently being developed. This is generally the case for launch vehicles. In those situations, trajectory data must be obtained from performance analysis of the vehicle itself. Once such trajectory data are obtained, utility program TRAJ2TRJ (contained in the /utility directory of the program disk) may be used to prepare a PCBoom3 .TRJ trajectory input file.

TRAJ2TRJ requires trajectory data as a sequence of sets of time, altitude, latitude, longitude, Mach number, climb angle, and heading angle. It will also accept first derivatives of Mach number, climb angle, and heading, but can compute these if they are not provided.

This program is provided as a separate utility, with detailed use instructions in file TRAJ2TRJ.DOC. It can accept original trajectory data in two particular formats, with semi-free-form structure. Source code is provided in the event it is necessary to adapt the program to other formats.

The output of TRAJ2TRJ is run separately, not within the PCBoom3 interface shell. Its output is a .TRJ file, which will automatically appear in the trajectory pick list when the PCBoom3 shell is later invoked by the PCB command.

4.0 PROGRAM STRUCTURE

PCBoom3 consists of a set of programs and batch files. The programs are:

- MIM – master input module. This presents the main menu, and controls flow through the entire system.
- FOBOOM3 – sonic boom calculation program. This is a self-standing full ray trace sonic boom model, capable of handling arbitrary maneuvers of any aircraft in a horizontally stratified atmosphere with winds. The program includes algorithms to calculate full signatures for both N-wave carpet booms and focus booms. It reads an input file created by MIM, and writes its results to a rather large output file.
- PCBFOOTB – reads FOBOOM3's output file and condenses it into a footprint file containing data for the isopemps and metric contours and a signature file for signatures and spectra.
- PCBPlot – draws contours and isopemps, as described in Section 3.3.2.1. This is also a self-standing program, and has as its input the output file written by PCBFOOTB.
- SIG and PLT, which select and plot signatures and spectra, as described in Section 3.3.2.2.

The software is started by typing PCB. This invokes batch file PCB.BAT which begins by running MIM. When a major action is specified, MIM will write a temporary batch file NEXT.BAT which sets up the appropriate combination of the other programs. MIM terminates, and PCB.BAT invokes NEXT.BAT. When the process is complete, the batch program re-runs MIM. The current case specification is stored in a temporary file, so that MIM restarts with the same information it had when it stopped.

Should the software terminate abnormally, the file NEXT.BAT will usually indicate what it was trying to do. The most recently written data files will also provide information. Should any problems arise, preserve these files for diagnostic analysis.

Sometimes abnormal termination will leave a scratch file XYZZY.TMP. The presence of this file may prevent PCBoom3 from running properly. If this happens, just delete XYZZY.TMP.

APPENDIX A

Files

A.1 Files Used

This system of programs uses a number of data files. The roles of some of these are of interest to the user, and the internal structures of some are of interest as well.

The following are files in which a user might have an interest. In this description, xxx = arbitrary name, yyy = arbitrary extension, case = user-supplied case name, and extensions in capital letters are required forms.

- xxx.ATT – atmosphere file, read/created by MIM.
- xxx.TRJ – trajectory (maneuver) file, read/created by MIM.
- case.CAS – case definition file, created by MIM.
- case.DAT – FOBOOM3 input file, created by MIM.
- case.PRM – “expert stuff” file, created by MIM.
- case.OUT – FOBOOM3 output file, input to PCBFOOTB.
- case.QWK – footprint data file. Created by PCBFOOTB, for input to PCBCont.
- case.SIG – signature data file. Created by PCBFOOTB, for input to SIG/PLT.
- case.IND – signature index file. Created by PCBFOOTB, for input to SIG/PLT.
- case.ASC – summary file, created by PCBFOOTB and viewed in MIM File/Results/ Examine Summary Table.
- case.AUX – scale and title file, created within and used by PCBCONT.
- xxx.yyy – ASCII contour output file from PCBCONT, as described in Section 3.3.2.1.
- xxx.yyy – Tabular signature or spectrum file from SIG/PLT, as described in Section 3.3.2.2.

Files xxx.ATT and xxx.TRJ are input files which can be created and/or edited from MIM. Their structure is of direct interest. The two xxx.yyy files are outputs whose purpose is exporting PCBoom3 results to user-supplied software. These four files are described in Section A.2.

File case.DAT includes all of the information in xxx.ATT, xxx.TRJ, case.PRM, and case.CAS. To archive a case, however, those four files (rather than case.DAT) should be preserved.

The file case.OUT generally has no archival value and may be deleted. All results are contained in case.QWK, SIG, IND, and ASC. One of each is generated per case. These should be preserved to archive output results.

A.2 Internal File Structures

A.2.1 Atmosphere File

This file has the following lines:

1. Title line, up to 60 characters.
2. Ambient pressure, psf, at the ground, and "below the ground" flag (character). Format F7.0, 3X, A1. The "below the ground" flag is normally blank.
3. Number of altitudes, NT, NWX, NWY, at which temperature, X-wind, and Y-wind, respectively, are defined. Format 3I5.
4. Temperature – definition altitudes, kilofeet. Format 10F7.1, as many lines as needed to fulfill NT. The first value is the nominal ground altitude, i.e, the altitude at which ground ambient pressure is given, and the first altitude entered in the aTmosphere/create New dialog.
5. Temperatures, degrees Fahrenheit, at each of the NT altitudes. Format 10F7.1.
6. If NWX is not zero, altitudes (kilofeet) at which X-winds are defined. Format 10F7.1.
7. If NWX is not zero, the corresponding X-wind values, feet per second. Format 10F7.1.
- 8, 9. Altitudes and winds for Y-wind data, if NWY is not zero.

Units in the file are as specified above. When creating the file via aTmosphere/create new, inputs may be in a variety of units. However, these are converted to kilofeet (altitude), degrees Fahrenheit (temperature), and feet/second (wind velocity) when the file is written. Wind is represented by its vector values, i.e., the direction in which it is blowing, rather than the meteorological sense of the direction from which it is coming.

Some calculations in PCBoom3 require atmospheric data below the ground. The program will normally extrapolate this itself. The user can directly control the extrapolation, via flag "below the ground". This requires manual editing of the file, as described in README.1ST.

A.2.2 Trajectory File

This file has the following lines:

1. Title line, up to 60 characters.
2. Initial Mach number and time. Format 2D20.14.
3. Initial x, y, altitude (feet), latitude (degrees north), heading (compass bearing: degrees clockwise from north), and flight path angle (degrees). Format 4F7.0, 2F7.2.
4. First derivatives of Mach number, heading, and flight path angle. Format 3D20.14.
5. Second derivatives of Mach number, heading, and flight path angle. Format 3D20.14.
6. Keyword TADVANCE or TADVANCE NEWDERS (Format A, beginning in Column 2), followed optionally by an event marker symbol in Column 21.
7. Advance time, i.e., the time for which the trajectory should be projected forward to a new point, seconds. Format F7.2. The projection is done at constant second derivatives.
8. If Line 6 was TADVANCE NEWDERS, new values of second derivatives of Mach number, heading, and flight path angle. Format 3D20.14.

The sequence of Lines 6, 7, and 8 may be repeated as many times as necessary. Also, the sequence of Lines 2, 3, 4, and 5 may be repeated at any time. If the 2, 3, 4, 5 sequence is repeated, it is up to the user to ensure that the defined trajectory points and times are kinematically consistent.

A.2.3 ASCII Contour File

This file, generated from PCBCont by selecting "Both together, plus ASCII file output", consists of the following lines:

1. 0.0, number of trajectory points, 0, 'traj'. Format f10.1, 2I5, a4.
2. x, y trajectory points, feet. Format 2F12.1, as many lines as specified in Line 1.
3. Contour values, number of points in contour, index (1-6) of contour value, text specifying units (psf, etc.). Format f10.1, 2I5, 5x, a4.
4. x, y pairs defining contour. Format 2FD.1, as many lines as specified in Line 3.

Lines 3 and 4 are repeated as needed to define all contours.

This file is usually created if the user wants to directly manipulate the contour data prior to sending to another application, such as a GIS. Utility program CONT2DXF (in the /utility directory of the distribution disk) will convert the contents of the ASCII contour file to DXF, with the trajectory, each contour, and the isopemps in its own layer. If no manipulation is needed, it may be preferable to generate an HPGL, postscript, or DXF file by specifying that plot device type and import that directly into the next application.

A.2.4 ASCII Signature and/or Spectrum File

These files are output by SIG/PLT by selecting tabular output. The files are self-explanatory. Header data defines the ray(s) involved, the type of signature, and the various metrics. The signature file provides psf versus time. The spectral file includes both the energy spectrum and the residual shock spectrum. Again, if the purpose is to import results into another application, it may be more appropriate to generate an HPGL, postscript, or DXF graphical file.