



DISTRIBUTION STATEMENT A
Approved for Public Release
Distribution Unlimited

Contents

Warhead Design Creativity Machine	1
Director's Corner	7
FYI	8
News	10
Calendar of Events	11

WSTIAC is a DoD Information
Analysis Center Sponsored by the
Defense Technical Information
Center and Operated by IIT
Research Institute

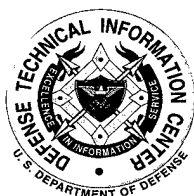

The Warhead Design Creativity Machine

By Stephen L. Thaler
Imagination Engines, Inc.

1.0 Introduction

Artificial neural networks (ANN) were victimized by some very bad press in the mid 1980s, as some overly zealous researchers promised more than they could possibly deliver. Since that time, these unique computational devices, inspired by the very benchmark of intelligence, the human brain, are significantly more advanced in their modeling capabilities, autonomy, and ease of use.

Perhaps the most significant development in this branch of AI has been the discovery of a powerful neural network paradigm that enables ANNs to perform beyond their customary role as *pattern detectors*, allowing them to now function as *novel pattern generators* that "invent" seminal concepts and plans of action. The machine intelligence enabled by this neural net paradigm shift, called a "Creativity Machine" (Thaler, 1995A, 1996A, 1997B; Yam, 1995B; Holmes, 1996B; Brown, 1997A), allows computers to automatically generate new and useful ideas via the pattern-based computing scheme utilized by the brain. In contrast to the older schools of artificial intelligence, such as *expert systems*, where sundry rules and atoms of knowledge must be laboriously assembled and entered into a computational system, such *Creativity Machines* capitalize upon the extraordinary ability of ANNs to simply "watch" a conceptual space and implicitly absorb the fundamental entities and heuristics therein. Rather than take the extremely inefficient and computationally costly "hit and miss" approach used by *genetic algorithms* to discover the most robust concepts, the Creativity Machine (CM) takes the approach used by the human cortex and not blind evolution. Intelligently, rather than randomly, this advanced neural system arrives at highly optimized concepts, including specially tailored and adaptive ordnance designs.

1.1 The Current Neural Network Paradigm – The Multilayer Perceptron

ANNs may be very succinctly described as computer codes that autonomously write themselves as they are exposed to representative input and output patterns. During this process of autonomous code writing, a system of computer-simulated on-off switches, called *computational neurons*, effectively wire themselves together using what I speak of tongue-in-cheek as a "mathematical spanking."

In practice, such spankings are achieved through a series of partial differential equations that constitute a process called *back-propagation* (Rummelhart, 1986). Using this methodology, a series of input patterns are fed through successive layers of neurons and their interconnecting *weights*, at first producing a series of initially erroneous output patterns. Successively, the network's errors, represented by the difference between actual and desired outputs, propagate from output to input end of the ANN, via the back-propagation equations, iteratively correcting

(Continued on page 2)

(Continued from page 1)

the numerical values of weights connecting the neurons. After a sufficient number of back-propagation cycles, the connection weights, tantamount to the expansion coefficients in a traditional statistical fit, produce a model that connects the known input-output pairs. When such ANNs consist of three or more layers of such computational neurons they are called multilayer perceptrons (MLP), and may be used to fit arbitrarily complex and often nonlinear functional relationships in very high dimensional spaces. The predictive accuracy of such models is contingent upon several factors, including the network architecture (i.e., the numbers of neurons in each of the successive layers, the functional form taken by each neuron, usually of sigmoid form, and a variety of parameters intrinsic to the back-propagation algorithm). The reliability of the MLP model fit also shares many of the limitations of traditional statistical modeling techniques wherein the quality and uniform sampling of data patterns are critical.

Close examination of a trained MLP reveals that the system of computational neurons, along with their connection weights, have assumed the form of "logic circuits," both discrete and fuzzy, that embody the many rules or heuristics embodying the input-output transformation. After all, the network is developing an accurate model, so it is compelled to "grow" an effective internal logic that is tantamount to a theory. Therefore, with sufficient dissection of the trained MLP, we uncover the

critical neural circuitry that combines the various features of the input patterns to faithfully produce the individual features of the output patterns.

In Figure 1, we show the weight architecture of a multilayer perceptron that accurately maps the design parameters of a potential warhead to its fragmentation field. It has been trained by supplying a variety of known warhead design specifications (i.e., length, width, casing thickness, explosive type and weight, geometry, striation pattern, etc.), and the associated fragmentation patterns (i.e., Z-data tables that have been generated from arena testing). Training input patterns consist of these design specifications, and polar sampling window $\Delta\theta$, centered at θ . Associated training output patterns consist of the initial fragment velocity at the polar angle, major fragment weight groups involved, and the numerical count of fragments within these respective weight groups. Once trained, we may enter as network inputs some set of design parameters for the warhead, a polar sampling width $\Delta\theta$ and then progressively ramp the value of θ to generate the fragmentation field of some real or hypothetical warhead design.

In other words, such an MLP trained on arena test data may serve as a Z-data table generator for new candidate warhead designs, or if embedded within a warhead, intelligently readapt the warhead inbound toward the target. Currently, using the available arena test data assembled from the Joint Munitions Effectiveness Manual (JMEM), root-

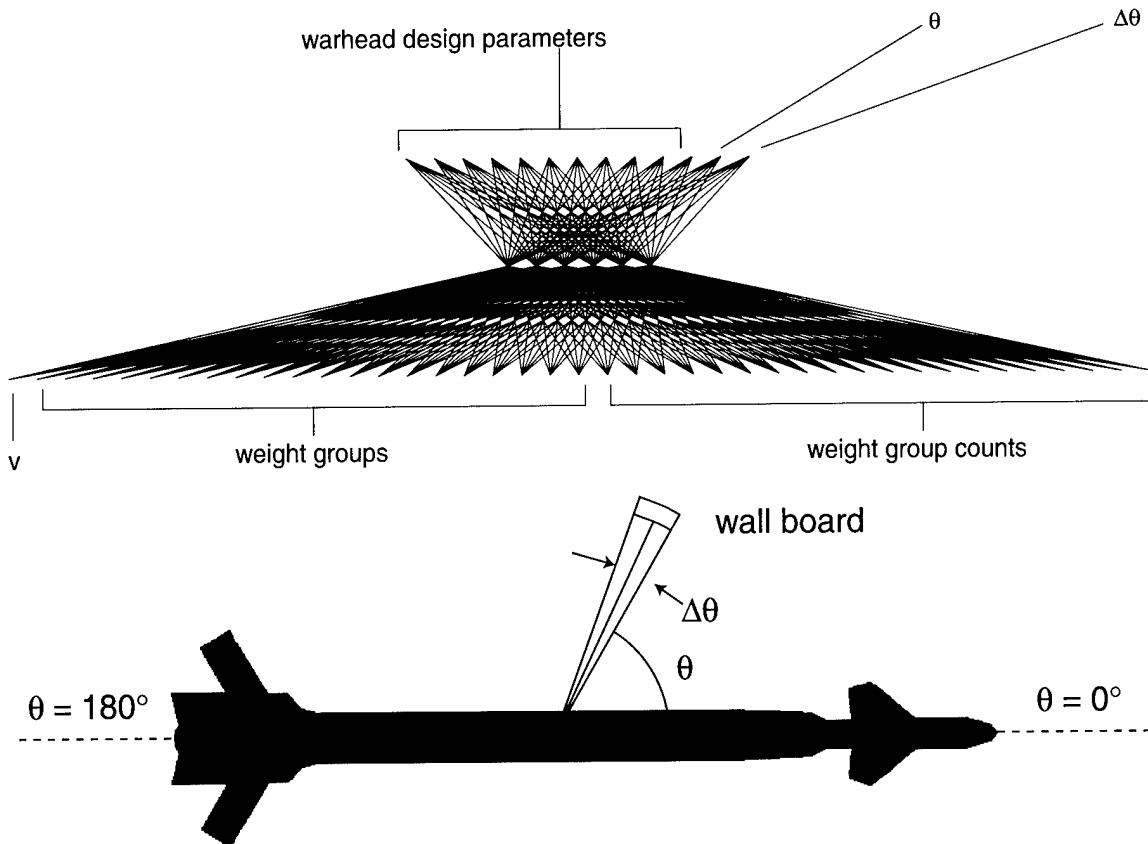

Figure 1. A multilayer perceptron (top) has trained upon multiple examples of warhead design specifications and corresponding arena test data (i.e., fragment velocities and fragment distributions). Applying some warhead design specification to the inputs of this network, we may set the polar angle inputs, θ , and the angular collection window, $\Delta\theta$, to calculate the resulting initial fragment velocity, weight groups, and weight group counts, within that polar sampling window. (Note: in arena tests, the fragment distribution captured by wall board spanning $\Delta\theta$ is assessed through manual fragment counts.)

(Continued on page 3)

(Continued from page 2)

mean-square training error is estimated at approximately 5%, reflecting the underlying experimental error in counting fragments following an arena test. Further, such Z-data generators have achieved 8% root-mean-square error in predicting the fragmentation field for warhead designs that have been isolated from the original training examples, to provide a test set to gauge the network's overall predictive power.

When contrasted with the very complex and costly first principles calculations performed using hydrodynamic and chemical thermodynamic theories, we see the MLP as a very practical and economical alternative. In effect, the MLP is autonomously devising its own warhead fragmentation theory!

1.2 The Future Neural Network Paradigm – The Creativity Machine

Although very powerful, the MLP approach to warhead design is limited, especially when we begin to consider how best to find a warhead design that will generate the needed beam spray. It would be very convenient, for instance, to use the MLP in reverse, applying some sought fragmentation field at the network's outputs and then observing the required warhead design to achieve that fragmentation pattern at the inputs. However, MLPs, by definition, are not bi-directional and only predict through forward propagation. Unfortunately such an approach would fail, even if we were to train a new MLP to map fragmentation patterns to design specifications for the following reason: the mapping between design specification and beam spray is intrinsically many-to-one. That is, there are potentially multiple warhead designs that may achieve the same fragmentation field. In a computational system that allows only one output pattern for any given input pattern, the design specification appearing at the outputs of the proposed net would effectively represent an average of several design solutions, that in itself may be an incorrect one.

One very impractical approach to finding the required warhead design would be to apply appropriately scaled random numbers, representing potential warhead design parameters, to the inputs of the network shown in Figure 1, until closely producing the necessary fragmentation field. The overwhelming problem with such a stochastic approach is that the vast majority of these potential designs, represented by random patterns, would be unphysical or nonsensical. For instance, shell casings may not be large enough to accommodate the prescribed weight of explosive, or the structural portion of the warhead may be far too heavy compared to its yield. These and other myriad constraints must be readily captured and exercised when feeding a stream of potential warhead concepts to an MLP that maps design specifications to fragmentation field.

To build an effective generator of new warhead designs we employ a special kind of neural network called an "imagination engine." To build such an inventive net for this particular problem, we train an MLP to produce an input-output mapping whose output patterns represent known warhead designs¹. Important to note is that as a result of such training, the net has automatically absorbed all of the implicit constraint equations (i.e., heuristics) that dictate how one design parameter, such as explosive weight, varies with all of the other design parameters. Typically, these constraint relations are captured within the final layer of weights of the MLP.

The effect that enables such a pre-trained MLP to generate a stream of new, potential warhead designs is one that I published (Thaler, 1995A) in a variety of scientific publications in the early to mid 90s. This extremely important neural network phenomenon is described as follows: If we administer transient disturbances (i.e., small algebraic variations) to the connection weights that precede the final weight layers of the trained MLP, the network tends to rapidly output a sequence of plausible output patterns, in this case representing potential warhead designs. The observation that each of these output patterns represents a physically realistic design owes itself to the fact that each disturbance dealt to a connection weight exercises the absorbed and implicit constraint equations. In effect, the network is "dreaming" new warhead designs. The underlying driver behind these emerging concepts is what I call "virtual input effect." (The network is hallucinating outputs, since inputs, tantamount to external sensory stimuli, are not being applied to the network.)

The most direct approach to building such imagination engines is through the use of what is called an *auto-associative network*. In training such a network, known warhead designs, are shown to it, both as the input and output patterns. Following training, when any known warhead design specification is applied to the inputs of this net, it is "deconstructed" through the preliminary weight layer(s), and then "reconstructed" at the MLP outputs, using the various constraint rules contained within the output weight layer. As in the general case of MLPs, the application of mild disturbances to the preliminary layer of connection weights in the auto-associative MLP produces plausible warhead designs at the net's output layer.

To make this effect more relevant, imagine that through years of study, warhead designers have established analytically represented equations of a general warhead, explicitly representing how any design parameter depends upon all others:

casing diameter	=	F_1 (casing length, explosive type, explosive weight,	..., fusing scheme)	(1)
casing length	=	F_2 (casing diameter, explosive type, explosive weight,	..., fusing scheme)	
explosive type	=	F_3 (casing length, casing diameter, explosive weight,	..., fusing scheme)	
.	.	.	.	
.	.	.	.	
fusing scheme	=	F_N (casing length, casing diameter, explosive weight,	..., casing striation)	

¹Note that for now, I am noncommittal about the nature of this network's input patterns.

(Continued on page 4)

(Continued from page 3)

Then, implementing this model on a digital computer, random variations can be administered to any arbitrary design parameter, as the computer algorithm automatically adjusts all others according to these master warhead equations (1). The truly amazing fact is that the imagination engine rapidly absorbs such equations, from raw warhead design data, in a matter of seconds or minutes, and then effectively generates myriad design variations through the parallel exercise of all these constraint equations through the perturbation of the network's connection weights.

In addition to experimenting with different values of design parameters, any small numerical perturbations delivered to the imagination engine's connection weights effectively softens or breaks the implicit rules absorbed therein. To this end, Imagination Engines, Inc. (IEI) has developed techniques wherein perturbations transiently "hop" among the connection weights of the imagination engine, rapidly experimenting with rule softening. One simple parameter, the magnitude of the mean synaptic perturbation (expressed as the fractional perturbation to each connection weight) is adjusted according to how drastically we intend to bend the usual design rules. The new warhead concepts are then relayed to an MLP of the type shown in Figure 1, that maps each of these could-be designs to the resulting predicted fragmentation field. The governing algorithm then accumulates a wealth of potential design specifications that will provide a desired beam spray pattern.

We belatedly note that whereas any MLP could have been used to produce output patterns representing known warhead designs, the auto-associative net is most expedient, for the following reason: We need not seek out associated data that would be used to create a *hetero-associative* mapping, wherein a warhead inventory code, for instance

is mapped to design specification. In contrast, all that we require are numerous examples of known warhead design specifications. Furthermore, the auto-associative version of the imagination engine is extremely useful for studying variations on the prototypical designs offered through the warhead training exemplars.

To achieve such design variations, we may apply to the imagination engine's inputs, some known warhead design specification, while simultaneously administering small, transient perturbations to connection weights in the preliminary weight layer. The result is that the stream of output patterns, new potential warheads, represent small design modifications to individual features of the warhead, as the other design features change in a self-consistent way to generally preserve the absorbed design heuristics.

2.0 The Warhead Design Creativity Machine

A simple Warhead Design Creativity Machine that has already been tested², is shown in Figure 2. There, we show the internally perturbed auto-associative imagination engine whose inputs are momentarily set to established warhead designs. The synaptic perturbations drive the network to produce plausible variations on these prototypical warheads. These potential warhead designs are then relayed to the lower critic network that now calculates an associated fragmentation pattern. The overall search process terminates when the combined networks discover, to within some predetermined root-mean-square error, the sought fragmentation pattern. The associated design specification now represents the sought warhead that propels the desired number of fragments into the required polar angles.

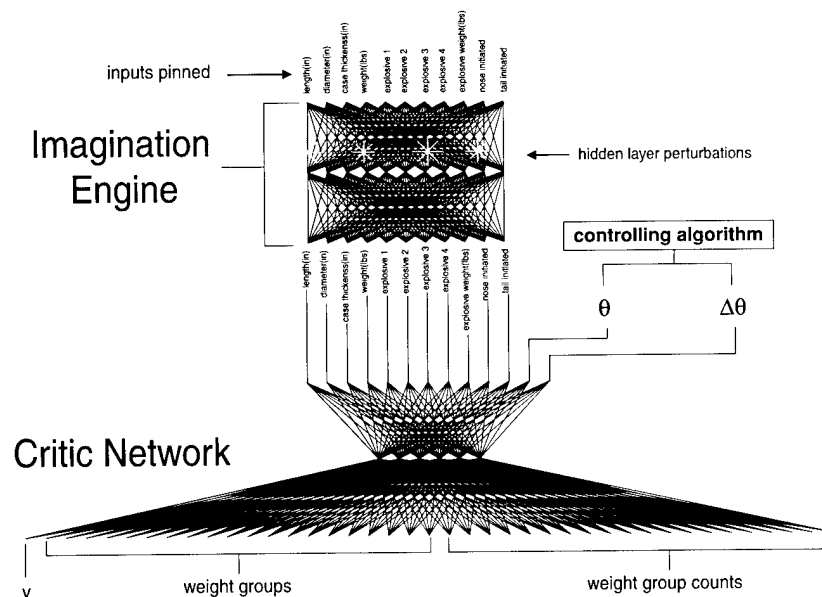

Figure 2. A Simple Warhead Design Creativity Machine. Starbursts within the imagination engine produce a series of plausible warhead designs, while the lower, critic net, calculates the associated fragmentation pattern. This process continues until the sought fragmentation field is generated. θ may then be varied, at set $\Delta\theta$, to explore the full angular dependence of the fragmentation field.

² contract F08630-99-C-0090 P00002 with AFRL/MNF, Eglin Air Force Base, FL

(Continued on page 5)

(Continued from page 4)

We note that in this initial effort, with only a limited sampling of warhead design specifications, it was only possible to consider a subset of possible design parameters that included length, diameter, case thickness, weight, explosive type, explosive weight, and the nature of fusing (nose or tail initiation). Rather than solve for the design specification required to give the full fragment distribution, we solved for a design specification projecting the required fragmentation distribution into some polar angle. Then, we were able to explore the full polar dependence of a promising design, by maintaining the candidate design specification at the imagination engine's inputs, and then ramping the value θ from 0 to 180 degrees. This process is shown in Figure 3, depicting the system's user interface, wherein we modify the characteristics of an exemplary fragment distribution and then allow the Creativity Machine to solve for the required design specification.

3.0 Rule Extraction from the Warhead Design Creativity Machine

Since the critic network in Figure 2 has formed a highly accurate mapping between warhead design specifications and resulting fragment field, the necessary "logic circuits" have developed within the critic net that

reflect the underlying physics of warhead detonation. Using IEI's proprietary weight pruning schemes, we may strip away all but the relevant connections to visually display these important relationships. In Figure 4, for example, is a selectively skeletonized critic network that reveals an important connection trace between the Boolean choice of tail initiation (yes or no) with the resulting fragment spread. From this trace we may readily discern that by choosing tail initiation, we enhance the lower fragment weight groups, while opting out of tail fusing (i.e., nose initiation) higher weight groups are augmented.

In a similar manner, we may skeletonize similar connection traces and then selectively interrogate them to discern highly valuable interrelationships that may of immense use to weapons designers. More advanced rule extraction techniques that have been pioneered by IEI, are capable of converting a neural to a semantic network, wherein logical rules governing the relationship between individual design features and the resulting fragmentation characteristics are automatically depicted through diagrams incorporating natural language (English).

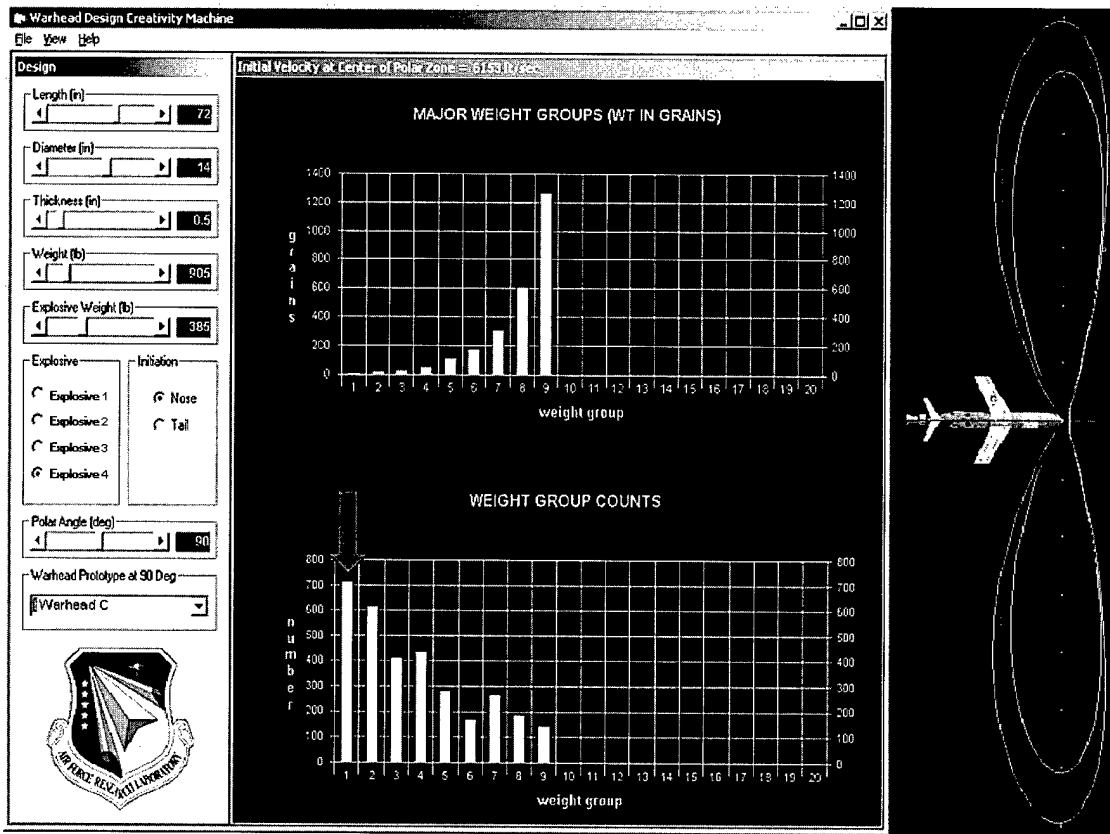

Figure 3. User Interface for Warhead Design Creativity Machine. Data point indicated by vertical arrow is modified to alter the fragmentation pattern. The underlying neural networks then solve for a warhead design specification potentially delivering this fragmentation field. Thereafter, the system may calculate comparative plots showing the variation of fragmentation pattern as the various design parameters are varied (right).

(Continued on page 6)

(Continued from page 5)

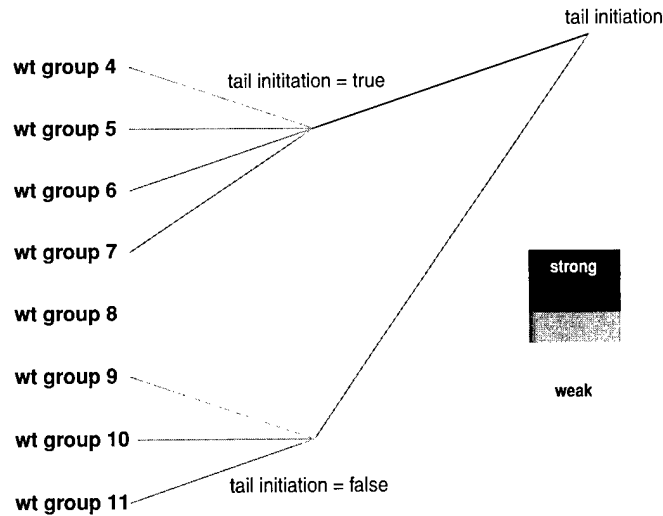

Figure 4. Rule Extraction from the Underlying Neural Networks. Here the critic network of the Warhead Design Creativity Machine has pruned itself of unnecessary connection weights to reveal how the presence or absence of tail initiation toggles the distribution of weight groups. The upper link contains an excitatory connection (deep purple), while the lower link (pale purple) is inhibitory. Therefore the upper link labeled "tail initiation = true" turns on the weight groups 4, 5, 6, and 7, while the lower trace marked "tail initiation = false" turns on weight groups 9, 10, and 11. The color legend shows the relative strengths of the weights involved in these connection traces.

4.0 Planned Improvements in the Warhead Design Creativity Machine

The foremost problem faced in training the Warhead Design Creativity Machine has been a shortage of available arena test data. In this first proof-of-principle experiment, only seven distinct and unclassified warhead designs were considered, combining JMEM derived design specifications with the results of corresponding arena tests carried out at the AFRL Munitions Directorate at Eglin AFB. The primary limitation of the overall system currently is the lower critic network pictured in Figure 2, that has demonstrated an approximate 8% root-mean-square prediction error for warhead designs swapped out of the original training set and then submitted to the network to sample generalization capacity. Because of this current limitation, the accuracy of the Creativity Machine may be lacking, especially as the imagination engine generates designs far removed from those used as training exemplars. For this reason, trial runs of this CM were run at low perturbation levels to produce warhead designs that were only slight variational themes on those seen by the imagination engine through training.

Based upon past Creativity Machine projects there is no doubt that as additional training exemplars are supplied, the ability of this architecture to produce reliable new designs will vastly improve. Likewise, as observed in past CM efforts, there will inevitably be a bootstrapping phase wherein new recommended designs are actually built and tested. Iteratively, through cumulative mistakes, Creativity Machines, just as people, become progressively more reliable in producing new, reliable, and useful concepts.

5.0 Automation of the Warhead Design Creativity Machine

Recent advances at IEL have led to a totally new type of MLP known as a "Self-Training Artificial Neural Network Objects" or "STANNO" (Thaler, 1996C, 1998). To make a very long story short, these neural network class templates contain their own integrated training algorithm. The very useful result is that multiple, self-training networks may be instantiated and combined into cascade structures, such as the Creativity Machine shown in Figure 2. Each of these STANNOS may then train in situ, without the necessity of removing and individually training each upon its associated exemplar database. Since most of the subtleties ordinarily dealt with by neural network practitioners are handled automatically within the STANNO, the overall Creativity Machine may be trained by those with little or no expertise in the area. This autonomy is extremely valuable to those working with classified, need-to-know data. Appropriately cleared personnel, without extensive knowledge of neural networks, may now train and exercise Creativity Machines through simple menu selections and mouse clicks.

The autonomy of the STANNO has also contributed to the development of large neural networks that may be implemented as client-server applications. Thus, some centralized neural network may be collaboratively trained by multiple users around the country via secure TCP/IP connections. In this manner multiple services could be supplying arena test data to a master neural network that is able to absorb the implicit rules relating warhead design and their resulting potencies. Through the client applications, users could independently query this central network for Z-data tables of hypothetical warhead designs. Similarly, the component networks of a warhead design Creativity Machine could be trained and interrogated in a similar client-server scheme.

(Continued on page 7)

(Continued from page 6)

6.0 Planned Refinements to the Warhead Design Creativity Machine

The next obvious step in improving the Warhead Design Creativity Machine is to enlarge the critic network to calculate the full fragmentation field (i.e., $0 \leq \theta \leq 180$) at once. To accomplish this task, much more arena test data will be required than was utilized in the prototype system, perhaps resorting to physics-based supercomputer simulations of arena tests. Once completed though, Z-data files generated for hypothetical weapons designs may be output to existing ray trace programs such as MEVA, to calculate blast effects upon various types of target structures (i.e., buildings, bunkers, etc.)

Additional critic modules may be added that monitor for other kinds of effects, including collateral damage to personnel, structures, and materials. Furthermore, additional Creativity Machine levels may be added that generate new potential chemical explosives that may be incorporated into the candidate warhead designs. Such an ancillary explosive materials Creativity Machines could be especially critical as new potential explosive materials, unaccompanied by thermodynamic data, are synthesized. Considering that extant codes such as JAGUAR rely upon chemical free energies of formation, this explosives discovery system would offer an immediate alternative to this highly successful code, perhaps absorbing that algorithm, and then refining itself through exposure to the behavior of new explosive materials and their highly irreversible thermodynamics.

7.0 The Future of Creativity Machines

Implicit in this discussion is the message that the Creativity Machine paradigm is a perfectly general methodology that may be applied to any conceptual space or area of human endeavor. Since these systems are totally autonomous in their formation, and because no explicit heuristics need be gleaned from their respective conceptual spaces, they may be functional and producing new concepts and courses of action in very little time. For this reason, Creativity Machines, serving

as viable alternatives to and improvements over genetic algorithms, are currently providing solutions within a variety of problem areas including materials discovery, personal hygiene products, synthetic music, robotics, communication satellite scheduling, as well as weapons design. Therefore, the sky is the limit as far as future applications of this very fundamental neural network paradigm, in both the civilian and military sectors as it offer's AI's "best bet" (Bushnell, 2001) to a fully creative brand of artificial intelligence.

8.0 References

- Rummelhart, D. E. (1986), *Parallel Distributed Processing: Explorations in the Microstructure of Cognition, Volume 1: Foundations*, MIT Press, Cambridge, MA, 328-330.
- Thaler, S. L. (1995A) "Virtual Input Phenomena" Within the Death of a Simple Pattern Associator, *Neural Networks*, 8(1), 55-65.
- Yam, P. (1995B) As They Lay Dying... Near the End, Artificial Neural Networks Become Creative, *Scientific American*, May 1995.
- Thaler, S. L. (1996A) Neural Networks That Create and Discover, *PC AI*, May/June 1996.
- Holmes, R. (1996B) The Creativity Machine, *New Scientist*, 20 January 1996.
- Thaler, S. L. (1996C) Self-Training artificial Neural Networks, *PC AI*, Nov/Dec 1996
- Brown, A. (1997A) Computers that create: No hallucination, *Aerospace America*, January 1997
- Thaler, S. L. (1997B) US05659666 – Device for the autonomous generation of useful information, issued 08/19/1997 and divisional patents
- Thaler, S. L. (1998) US05845271 – Non-Algorithmically implemented artificial neural networks and components thereof, issued 12/01/1998 and divisional patents
- Bushnell, D. M. (2001). Future Strategic Issues/Future Warfare [Circa 2025], NASA Langley Research Center.

About the Author: Dr. Stephen Thaler has been the President & CEO of Imagination Engines, Inc. since 1995. He is also the Principal Scientist for Sytex, Inc. Previously he was a Production Chemist for Mallinckrodt Nuclear (1973-74) and a Principal Technical Specialist at McDonnell Douglas (1981-1995). He has a B.A. from Westminster College, a Ph.D. in physics from the University of Missouri-Columbia, and is a graduate of McDonnell Douglas Voluntary Improvement Program in Artificial Intelligence. Dr. Thaler is an expert in advanced neural networks and holds a number of patents in this area. He can be contacted at (314) 576-1617, sthaler@imagination-engines.com or through the IEI web site at <http://www.imagination-engines.com>.

Smart Precision Weapons Training Seminar

LOCATION: Huntsville, Alabama, 2002

5-7 March

23-25 April

18-20 June

20-22 August

(Seminar starts at 8:00 AM Tuesday and ends at 12:00 PM Thursday)

The Weapon Systems Technology Information Analysis Center (WSTIAC) developed this 2½ day Smart Weapons Training Seminar to provide a comprehensive understanding of smart weapons and related technologies. This seminar is aimed at providing general knowledge about smart weapons technology and a source of current information on selected U.S. and foreign smart weapons, to include system description, concept of employment, performance characteristics, effectiveness and program status.

For additional information, contact: Ms. Kelly Hopkins, Seminar Administrator, at (256) 382-4747, fax: (256) 382-4702 or by e-mail: khopkins@iitri.org

Director/Chief Scientist's Corner



by Dr. Wes Kitchens

Homeland defense has become a high priority for our Nation as a result of the September 11th terrorist attacks. Many new initiatives have been started in direct response to these terrorist attacks and the White House Office of Homeland Security has been established with former Governor Tom Ridge (PA) as Director. The Office of Homeland Security is responsible for conducting cross-agency coordination, identifying how much money each agency is spending on homeland defense, quantifying the gaps that exist in current programs and identifying what needs to be done to fill them. Many of the technologies we have developed for weapons systems can and will be employed to support our homeland defense efforts. Three technologies that immediately come to mind are: (1) sensing and identifying chemical and biological agents; (2) detecting and neutralizing explosives and unexploded ordnance; and (3) air and missile defense. Air and missile defense is thought by many to be a critical component of any robust homeland defense strategy and it will undoubtedly receive increased attention. The United States recently notified Russia that we were going to withdraw from the 30-year old Anti-Ballistic Missile (ABM) Treaty. President Bush explained why we were doing this during his remarks in the Rose Garden on 13 December 2001: "I have concluded the ABM treaty hinders our government's ability to develop ways to protect our people from future terrorist or rogue state missile attacks. We know that the terrorists, and some of those who support them, seek the ability to deliver death and destruction to our doorstep via missile. And we must have the freedom and the flexibility to develop effective defenses against those attacks."

No matter what you may think about the prospects for achieving a robust missile defense system, it is clear from President Bush's remarks that this administration plans to pursue such a system. As most of you already realize, the United States currently has no capability to shoot down a ballistic missile launched against an American city. This poses a critical risk to the United States and we need to apply an appropriate level of resources to reduce our vulnerability to this threat. We are attempting to

develop a missile defense system to defend the forces and territories of the United States, our allies and friends against ballistic missile threats from all ranges, with the goal of achieving a layered defense that will provide multiple engagement opportunities along the total flight path of a threat missile. The Missile Defense Agency, MDA (formerly BMDO) has successfully demonstrated that a long-range intercontinental ballistic missile target vehicle launched from Vandenberg AFB, CA can be intercepted over the Pacific Ocean by a prototype hit-to-kill missile launched from 4800 miles away in the Marshall Islands. The impressive test results (3 successful intercepts out of 5 tries) confirm that it's possible to hit a bullet with a bullet, at least in the case of a relatively benign threat that doesn't employ counter-measures. General Kadish and the MDA are congratulated on these recent successes and the foundation they provide for our future missile defense system. While it's true that the administration's missile defense plans remains controversial in some circles, our missile defense efforts will clearly grow in importance as we focus more attention and resources on meeting our homeland defense requirements.

This issue of the *WSTIAC Newsletter* features a technical paper entitled "The Warhead Design Creativity Machine," by Dr. Stephen L. Thaler, Imagination Engines, Inc., Dr. Thaler's article discusses how advanced neural network technology can be applied to "predict" the fragmentation pattern of a warhead. One can imagine a situation at some time in the future where algorithms such as Dr. Thaler's are embedded in guidance-integrated fuze "nanochips" and used to selectively fuze an in-bound smart munition to optimize its fragmentation pattern depending on the target type and the munition/target encounter dynamics.

We welcome your feedback about the *WSTIAC Newsletter* and solicit your suggestions for future topics you would like to see included. You can reach me by email at wkitchens@iitri.org or by phone at (703) 933-3317.

FYI

DoD Studies Medical Impact of Depleted Uranium in the Balkans

The Department of Defense released an information paper, "Depleted Uranium Environmental and Medical Surveillance in the Balkans," which summarizes medical and environmental assessments performed in the Balkans area by a number of countries. On the whole, these assessments have not found any connections between depleted uranium exposure in the Balkans and negative health effects. Most of the work assessed was done independently, by organizations outside the Defense Department. The information paper examines assessments performed by the United Kingdom Royal Society, the World Health Organization, the United Nations Environmental Programme and others.

Investigators supporting the special assistant for Gulf War illnesses, medical readiness and military deployments compiled and analyzed those reports and referenced them in the new information paper. Most of the cited references are available in public libraries or on the Internet.

The special assistant's support staff is the same organization that previously investigated depleted uranium use in the Gulf War. Both tanks and aircraft employed depleted uranium ammunition in the Gulf War. However, all the depleted uranium used in the Balkans was in the form of 30-millimeter rounds fired from Air Force A-10 aircraft. About 10,000 rounds were fired in Bosnia and approximately 31,000 rounds were fired in Kosovo. That adds up to nearly 13 tons of depleted uranium, much less than the 320 tons of depleted uranium used during the Gulf War.

Concerns about possible health effects of depleted uranium in Europe were first raised by newspaper reports. Italian media reports initially tried to link an apparent rise in the incidence of leukemia in Balkan veterans to exposure to depleted uranium. After an extensive scientific study, the Italian government concluded that the incidence of leukemia was not as high in Balkan veterans as it was in the general population. Many other countries started medical screening programs for their Bosnia veterans. So far, none has reported elevated uranium levels in their soldiers' urine, or any negative health consequences they attribute to depleted uranium exposure.

Because depleted uranium is a heavy metal, it can be potentially harmful under certain circumstances. For that reason, the NATO nations have instituted training in the safety precautions to use in an area where depleted uranium was used militarily. Much of this training is based on the training programs created by the U.S. Army.

Information papers are reports of what the Defense Department knows today about military procedures and equipment. This information paper is intended to provide a basic understanding of depleted uranium use in the Balkans. Although not an investigative report, the report will be updated if additional information becomes available. This report is posted on the DeploymentLINK Web site at <http://deploymentlink.osd.mil/du-balkans/index.html>

NEWS RELEASE from the United States Department of Defense No. 552-01
October 30, 2001.

The WSTIAC Newsletter is the current awareness publication of the Weapon Systems Technology Information Analysis Center (WSTIAC). WSTIAC, a Department of Defense (DoD) Information Analysis Center (IAC), is administratively managed by the Defense Information Systems Agency (DISA), Defense Technical Information Center (DTIC) under the DoD IAC Program. The Contracting Officer's Technical Representative (COTR) for WSTIAC is Mr. H. Jack Taylor, ODUSD (S&T), Defense Pentagon, Washington, D.C. 20301-3080, (703) 588-7405. IIT Research Institute operates WSTIAC, which services Government, industry, and academia as a Center of Excellence in Weapon Systems Technology.

WSTIAC Director: Dr. Wes Kitchens
703.933.3317,
Email: wkitchens@iitri.org

Database Inquiries: Vakare Valaitis
703.933.3362
Email: vvalaitis@iitri.org

Internet: <http://iac.dtic.mil/wstiacc/>

All data and information herein reported are believed to be reliable; however, no warrant, expressed or implied, is to be construed as to the accuracy or the completeness of the information presented. The view, opinion, and findings contained in this publication are those of the author(s) and should not be construed as an official Agency position, policy, or decision, unless so designated by other official documentation.

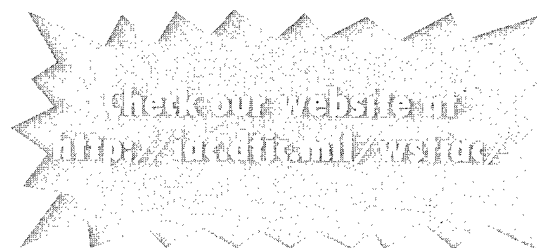

Who Ya Gonna Call?

When landline communications links are on the fritz and the job is too massive for local cellular communications, the Naval Research Laboratory (NRL) in Washington, D.C., stands ready to answer the call. NRL has outfitted Humvees with the capability of immediately providing two-way satellite commercial links and a private cellular telephone network. The system can even handle streaming video.

"The first emergency response teams to a disaster often falsely believes there will be basic infrastructure in place, such as phone lines, in place to support their work. We can deliver telephone and data connectivity anywhere," said Chris Herndon, the NRL project manager Infralynx (Infrastructure Linkage and Restoration), the Humvee communications project.

Originally designed to support several U.S. Navy and Marine Corps operations, the modular communications components installed on the Humvees are entirely self-contained and can be configured to fit the needs of a particular civilian or military situation.

NRL was able to mobilize two Humvees within 12 hours when the Federal Emergency Management Administration (FEMA) agency-wide request for communications assistance in the days following New York City's World Trade Center collapse. Just when the Humvees were to set off for New York City, FEMA decided additional communications assistance was not needed, but the exercise proved to the NRL team just how quickly they could customize the Humvee-based communications units and get them on the road.

Humvee is short for HMMWV, a military term for "High Mobility Multipurpose Wheeled Vehicle," while Hummer refers to the similar vehicles produced for civilian markets.

For more information on NRL's Humvee-based communications system if you are working media, please call Audrey Haar, 703-696-2869, or email haara@onr.navy.mil. *Office of Naval Research Public Affairs Office*

Airborne Laser Changes Affiliation

KIRTLAND AIR FORCE BASE, N.M. – In a brief ceremony here on Friday (Oct. 12) the Airborne Laser (ABL) formally ended its nearly decade-long affiliation with the Space and Missile System Center (SMC), transitioning its personnel management functions to the Aeronautical Systems Center (ASC) at Wright Patterson Air Force Base, Ohio. The move had been in the planning stages almost since the time the Airborne Laser was conceived in the early Nineties but was moved forward this summer when the Air Force transferred SMC to its Space Command. Since ABL was not considered a space program, the transition to ASC was advanced by several years.

Both SMC and ASC were under the Air Force Materiel Command, also based at Wright-Patterson. Under the transition, members of the Kirtland-based ABL System Program Office will transfer to ASC slots but all personnel will remain in New Mexico. On November 1, ABL transferred funding and program management to the Ballistic Missile Defense Organization, a joint service organization under the Office of the Secretary of Defense that oversees missile defense programs for all the services.

ABL currently is building the country's first boost-phase ballistic missile defense system. The weapon system, which features a megawatt-class high-energy laser, will be housed aboard a modified Boeing 747-400 freighter. The aircraft, YAL-1A, which stands for prototype Attack Laser, model 1A, will be rolled out of the Boeing facility in Wichita, Kan., on November 10. Following three months of ground tests, the aircraft will begin flight tests to re-certify its airworthiness. Once that process has been completed, YAL-1A will be flown to Edwards Air Force Base, Calif., where the Beam Control/Fire Control, and laser segments will be installed and tested. The culmination of testing is scheduled to come late in 2003 when YAL-1A shoots down a Scud-like missile over the Pacific Ocean.

Air Force Research Laboratory, Office of Public Affairs Ken Englade

PLAN NOW TO ATTEND!

AeroSense

SPIE's 16th Annual International Symposium on

Aerospace/Defense Sensing, Simulation, and Controls

1-5 April 2002

Gaylord Palms Resort and Convention Center
Orlando, Florida USA

Learn about the latest developments in:

- **Chemical and Biological Sensing**
- **Transnational Defense Technologies, Systems, and Architectures**
- **Guidance and Control**
- **Sensor Technologies**
- **and more.**

 **SPIE** The International Society
for Optical Engineering

spie.org/info/or

SPIE P.O. Box 10 Bellingham, WA 98227-0010 USA Phone: +1 360 676 3290 Fax: +1 360 647-1445 Email: spie@spie.org

Calendar of Events

9-20 March 2002
 Navy Ballistic Missile Defense Conference
 Crystal City Forum
 Arlington VA
 For additional information:
 Email: rmohrmann@ndia.org
<http://register.ndia.org/interview/register.ndia?~Brochure~2160>

19-21 March 2002
 2002 Joint Undersea Warfare Conference
 San Diego CA
 For additional information:
 Email: kwilliams@ndia.org
<http://register.ndia.org/interview/register.ndia?~Brochure~2260>

25-28 March 2002
 Non-Lethal Defense V
 Hyatt Regency
 Reston VA
 For additional information:
 Email: asaliski@ndia.org
<http://register.ndia.org/interview/register.ndia?~Brochure~2420>

1-5 April 2002
 AeroSense
 Gaylord Palms Resort and Convention Center
 Orlando FL
 For additional information:
<http://spie.org/Conferences/Calls/02/or/>

15-18 April 2002
 Gun and Ammunition Conference and Exhibition
 Panama City FL
 For additional information:
 Email: djenks@ndia.org
<http://register.ndia.org/interview/register.ndia?~Brochure~2590>

17-19 April 2002
 Missiles and Rockets Conference and Exhibition
 Panama City FL
 For additional information:
 Email: djenks@ndia.org
<http://register.ndia.org/interview/register.ndia?~Brochure~2630>

21-26 April 2002
 High Power Laser Ablation 2002
 Taos NM
 For additional information:
<http://spie.org/Conferences/Calls/02/hp/>

29 April-1 May 2002
 Fuze Conference
 Marriott River Walk
 San Antonio TX
 For additional information:
 Email: rmohrmann@ndia.org
<http://register.ndia.org/interview/register.ndia?~Brochure~2560>

6-10 May 2002
 Live Fire Test and Evaluation
 Monterey CA
 For additional information:
 Email: pedmonson@ndia.org
<http://register.ndia.org/interview/register.ndia?~Brochure~2190>

11-15 May 2002
 IEEE International Conference on Robotics and Automation
 Crystal Gateway Marriott Hotel
 Washington DC
 For additional information:
<http://www.icra-iros.com/icra2002/index.html>

27-29 May 2002
 9th Saint Petersburg International Conference on Integrated
 Navigation Systems
 St Petersburg Russia
 For additional information:
 Contact: Dr. John Niemela 732 427 4635
 Email: john.niemela@mail.monmouth.army.mil
<http://www.elektropribor.spb.ru/confs/icins02/index.html>

18-20 June 2002
 2002 Warheads and Ballistics Classified Symposium
 Colorado Springs CO
 For additional information:
broulstone@ndia.org

21-25 July 2002
 Joint Advanced Weapon Systems Sensors, Simulation and Support
 Symposium (JAWS S3)
 Air Force Academy
 Colorado Springs CO
 For additional information:
CGriffith@anteon.com

23-27 September 2002
 20th International Symposium on Ballistics
 Rosen Center Hotel, Orlando FL
 For additional information:
http://register.ndia.org/interview/register.ndia?PID=Brochure&SID=_OK00X0ZV8&MID=2210

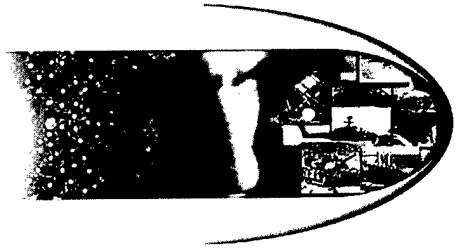

Information Request

Please return this form to...
IIT Research Institute/WSTIAC
ATTN: Publication Department
215 Wynn Drive, Suite 101
Huntsville, AL 35805

or fax...
256.382.4702

- Checkboxes for adding name to mailing list, sending technical area task information, general information, correcting address information, sending subscriber information, and sending publications list.

Name:
Organization:
Address: Telephone:
Fax:
E-mail:

Please also add my name to the following mailing lists:

- Checkboxes for MTIAC (Manufacturing Technology Quality), RAC (Reliability Maintainability and Processes), AMPTIAC (Advanced Materials and Testing), MSIAC (Modeling and Simulation), and IATAC (Information Assurance).



215 Wynn Drive, Suite 101
Huntsville, AL 35805

1901 N. Beauregard Street, Suite 400
Alexandria, VA 22311

Nonprofit Organization
U.S. Postage Paid
Huntsville, AL
Permit No. 4

Inside this issue...

- Warhead Design Creativity Machine
Director's Corner
FYI
Smart Weapons Training Seminar
News
Calendar of Events

6*1*****5-DIGIT 22060
D CASWELL 4702
DEFENSE TECH ANALYSIS OFFICE
8725 JOHN J KINGMAN RD
TECH STUDIES DIV DLASTE 2533
FORT BELVOIR VA 22060-6217
Barcode