

**UNCLASSIFIED**

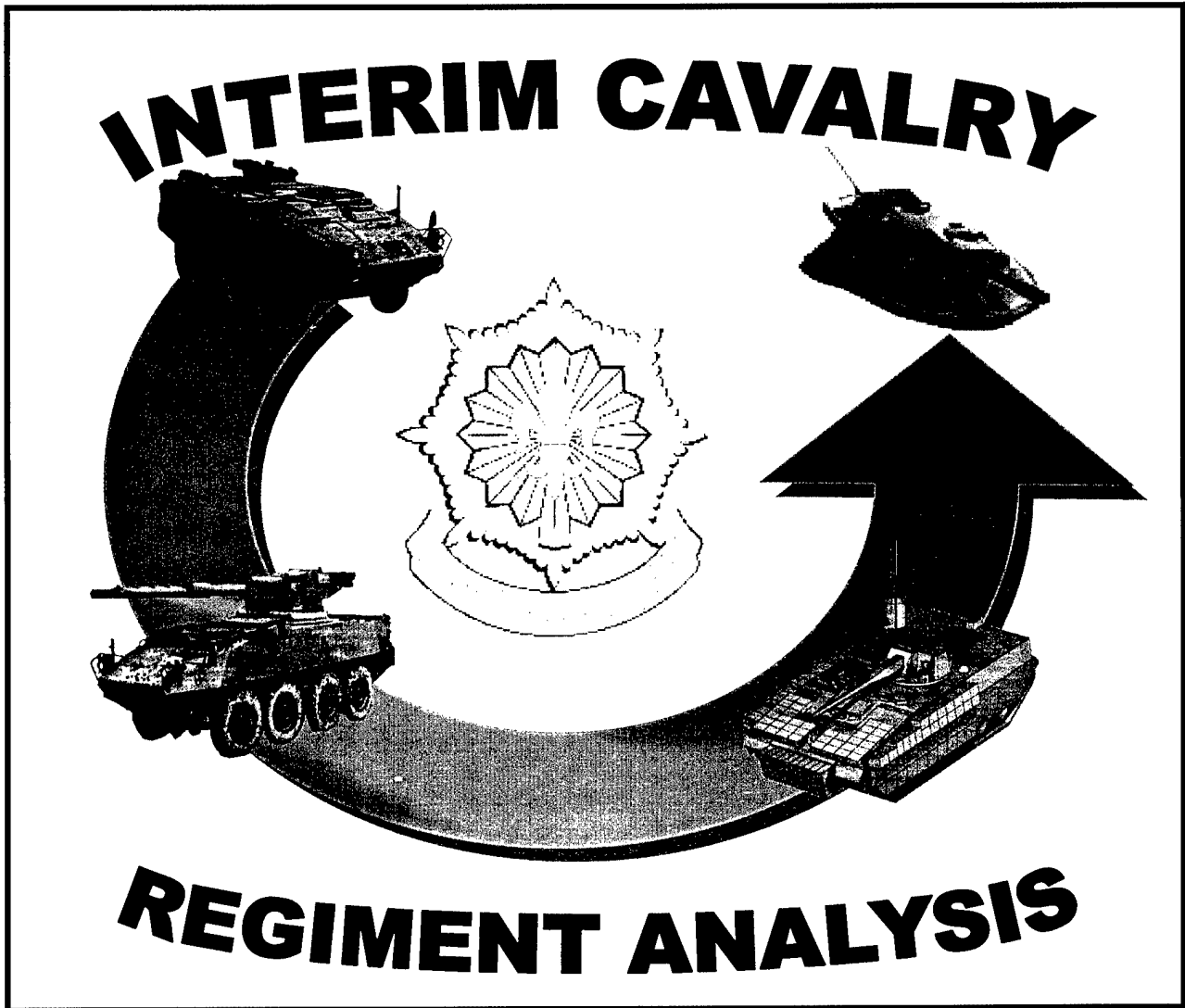

**JUNE 2001**

**DEPARTMENT OF ARMY  
US ARMY ARMOR CENTER  
FORT KNOX, KENTUCKY 40121**

**UNCLASSIFIED**

**20020314 049**

**NOTICES**

**DISTRIBUTION STATEMENT**

Approved for public release; distribution is unlimited.

**DISCLAIMER**

The findings in this report are not to be construed as an official Department of the Army position, unless so designated by other authorized documents.

# REPORT DOCUMENTATION PAGE

*Form Approved*  
*OMB No. 0704-0188*

Public reporting burden for this collection of information is estimated to average 1 hour per response, including the time for reviewing instructions, searching existing data sources, gathering and maintaining the data needed, and completing and reviewing the collection of information. Send comments regarding this burden estimate or any other aspect of this collection of information, including suggestions for reducing this burden, to Washington Headquarters Services, Directorate for Information Operations and Reports, 1215 Jefferson Davis Highway, Suite 1204, Arlington, VA 22202-4302, and to the Office of Management and Budget, Paperwork Reduction Project (0704-0188), Washington, DC 20503.

<b>1. AGENCY USE ONLY (Leave blank)</b>		<b>2. REPORT DATE</b> 1 June 2001	<b>3. REPORT TYPE AND DATES COVERED</b> Final 15 Nov 2000 - 1 June 2001	
<b>4. TITLE AND SUBTITLE</b> Interim Cavalry Regiment Analysis			<b>5. FUNDING NUMBERS</b>	
<b>6. AUTHOR(S)</b> MAJ Karl Gingrich, Mr. Lawrence G. Vowels				
<b>7. PERFORMING ORGANIZATION NAME(S) AND ADDRESS(ES)</b> U.S. Army Armor Center Directorate of Force Development Attn: ATZK-FDO Fort Knox, Kentucky 40121			<b>8. PERFORMING ORGANIZATION REPORT NUMBER</b>	
<b>9. SPONSORING / MONITORING AGENCY NAME(S) AND ADDRESS(ES)</b>			<b>10. SPONSORING / MONITORING AGENCY REPORT NUMBER</b>	
<b>11. SUPPLEMENTARY NOTES</b>				
<b>12a. DISTRIBUTION / AVAILABILITY STATEMENT</b> Approved for public release; distribution is unlimited			<b>12b. DISTRIBUTION CODE</b>	
<b>13. ABSTRACT (Maximum 200 words)</b> The reorganization of the 2nd Armored Cavalry Regiment (ACR) was examined using the Janus model. The primary questions being examined were the different organizational structures and the sizing of the Mobile Gun System (MGS) Platoon. This analysis utilized two scenarios; a zone reconnaissance and a moving flank guard on Eastern European terrain. TRADOC Analysis Center (TRAC) at White Sands Missile Range hosted and assisted in the modeling on their Janus suite. The organizational structures that were analyzed included the current HMMWV based organization employed by the 2nd ACR, an updated organization equipped with Interim Armored Vehicles (IAV), and the Interim Brigade Combat Team (IBCT) organization. The alternative sizes for the MGS Platoon were three and four MGS per platoon.				
<b>14. SUBJECT TERMS</b> Armored Cavalry Regiment, Interim Cavalry Regiment, Interim Brigade Combat Team, Interim Armored Vehicle, Mobile Gun System, Organizational Design, Simulation, Janus, Modeling			<b>15. NUMBER OF PAGES</b> 28	
			<b>16. PRICE CODE</b>	
<b>17. SECURITY CLASSIFICATION OF REPORT</b> Unclassified	<b>18. SECURITY CLASSIFICATION OF THIS PAGE</b> Unclassified	<b>19. SECURITY CLASSIFICATION OF ABSTRACT</b> Unclassified	<b>20. LIMITATION OF ABSTRACT</b> UL	

## ACKNOWLEDGEMENTS

The analysis team would like to acknowledge the help and support of the following agencies and personnel.

### US ARMY ARMOR CENTER

MAJ Karl Gingrich  
CPT David Lindow  
SFC Willie Brown  
SFC Daniel Bonogofski  
Mr. Lawrence Vowels  
Mr. Ted Maciuba

### US ARMY FIELD ARTILLERY SCHOOL

MAJ Dewey Granger

### US ARMY AVIATION CENTER

CPT Shelby Richardson

### THREAT SUPPORT DIRECTORATE

Mr. Charles Ennis

### JANUS TRAC-WSMR TEAM

MAJ Rick O'Donnell  
MAJ Stephen Vallejos  
MAJ Kenneth Harris  
MAJ James Daniels  
MAJ Randy Murray  
SFC(P) Randall Richardson  
SFC Anthony Williams  
Ms. Wilma Durio  
Mr. Ken Haubner

Mr. James Ritter  
Mr. Barney Watson  
Mr. James Wittwer  
Mr. Scott Huskey  
Mr. Masashi Nakamura  
Mr. Michael Black Eyes  
Mr. Max Nicely  
Mr. Ron Saylor  
Mr. Pat Crowder

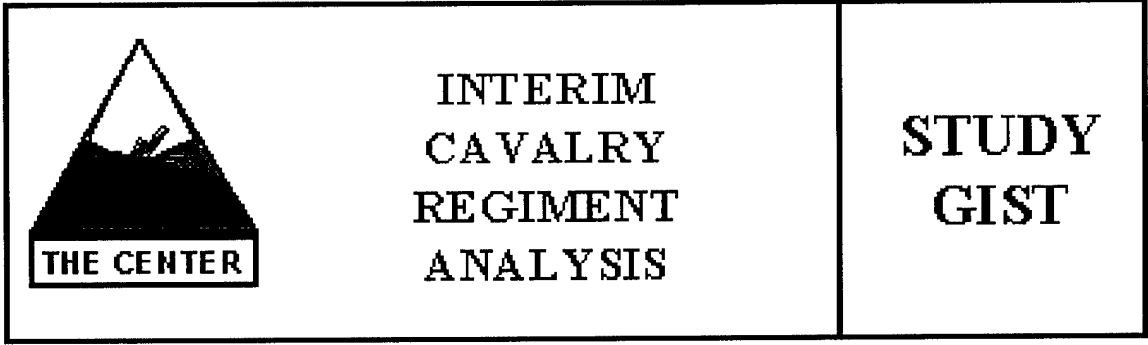

**THE REASON FOR PERFORMING THE STUDY** was to analyze different organizational structures and the sizing of the mobile gun system platoon.

**THE PRINCIPAL RESULTS** of this analysis are the Interim Cavalry Regiment and the Interim Brigade Combat Team each provides a better zone reconnaissance than the current 2<sup>nd</sup> Armored Cavalry Regiment. The Interim Cavalry Regiment performs the zone reconnaissance mission quicker than the Interim Brigade Combat Team. The force equipped with four vehicle mobile gun system platoons was a more flexible unit that was able to cover a larger frontage with less risk than a force equipped with three vehicle mobile gun system platoons.

**SCOPE:** The analysis focused on a squadron (+) sized force in Janus for the zone reconnaissance mission. The platoon size analysis was a troop sized force in Janus using a flank guard mission. The analysis was limited to three iterations for each alternative in each scenario.

**THE STUDY OBJECTIVES** were to determine and compare the effectiveness of the current cavalry regiment force structure with two alternative force structures that utilize the interim armored vehicle. To examine the difference in operational effectiveness between three and four mobile gun system vehicle platoons in the interim cavalry regiment force structure.

**THE BASIC APPROACH** used to accomplish the analysis was to examine each of the alternatives within the appropriate scenario within Janus a man-in-the-loop simulation at TRADOC Analysis Center, White Sands Missile Range.

**THE STUDY PORPONENT/AGENCY** was the United States Army Armor Center.

**TABLE OF CONTENTS**

SF 298 ..... i

ACKNOWLEDGEMENTS ..... ii

STUDY GIST..... iii

TABLE OF CONTENTS ..... iv

ABSTRACT ..... v

LIST OF FIGURES ..... vi

INTRODUCTION..... 1

ANALYSIS ISSUES ..... 1

STUDY ISSUE 1 ..... 1

STUDY ISSUE 2 ..... 18

CONCLUSIONS ..... 26

RECOMMENDATIONS ..... 26

## ABSTRACT

The reorganization of the 2nd Armored Cavalry Regiment (ACR) was examined using the Janus model. The primary questions being examined were the different organizational structures and the sizing of the Mobile Gun System (MGS) Platoon. This analysis utilized two scenarios; a zone reconnaissance and a moving flank guard on Eastern European terrain. TRADOC Analysis Center (TRAC) at White Sands Missile Range hosted and assisted in the modeling on their Janus suite.

The organizational structures that were analyzed included the current HMMWV based organization employed by the 2nd ACR, an updated organization equipped with Interim Armored Vehicles (IAV), and the Interim Brigade Combat Team (IBCT) organization. The alternative sizes for the MGS Platoon were three and four MGS per platoon.

## **LIST OF FIGURES**

Number		Page
1	Current 2 <sup>nd</sup> ACR Organization	2
2	Interim Cavalry Organization	2
3	Interim Brigade Combat Team	3
4	Scenario Setting	4
5	Road to War (Long Term)	5
6	Road to War (Short Term)	5
7	Maneuver Box	6
8	Regimental Scheme of Maneuver	7
9	IBCT Maneuver Scheme	8
10	Initial Threat Laydown	9
11	Key Scenario Assumptions	9
12	Modeling Assumptions	10
13	Detection of High Payoff Targets	11
14	ACR's Movement Facilitation	12
15	ICR's Movement Facilitation	12
16	IBCT's Movement Facilitation	13
17	Force Exchange Ratio Comparison	15
18	Survivability Comparison	16
19	Armor Defeating Capability	17
20	Issue 1 Conclusions	18
21	MGS platoon Alternative Force Structures	19
22	Flank Guard Maneuver Area	20
23	Friendly Scheme of Maneuver	21
24	Threat Scheme of Maneuver	22
25	Mission Accomplishment Comparison	23
26	Force Exchange Ratio Comparison	24
27	System Exchange Ratio Comparison	24
28	Survivability Comparison	25
29	Armor Defeating Comparison	26
30	Issue 2 Conclusions	27

# UNCLASSIFIED

## INTERIM CAVALRY REGIMENT ANALYSIS

### 1. (U) INTRODUCTION

- 1.1 (U) In July 2000, the Commanding General of TRADOC chartered a Blue Ribbon Panel to examine the mismatch between roles and missions versus capability and develop a new Operational and Organizational (O&O) concept to address the mismatch. As a result of this charter, the U.S. Army Armor Center held a number of Blue Ribbon Panel meetings in October 2000 through January 2001 to begin this process.
- 1.2 (U) The Blue Ribbon Panel meetings tasked a number of analysis efforts that would increase the understanding of the issues and accelerate the development of the O&O concept. This report details the third such analysis effort directed by the Blue Ribbon Panel. This report covers the force effectiveness evaluation of different organizational structures and an examination of the size of the Mobile Gun System (MGS) Platoon in one of the alternative structures.
- 1.3 (U) The Directorate of Force Developments (DFD), U.S. Army Armor Center (USAARMC), in concert with personnel from TRADOC Analysis Center (TRAC) and U.S. Army Infantry Center (USAIC) conducted the Janus modeling at TRAC, White Sands Missile Range during the period 22 January-9 February 2001. The analysis included the following organizational structures:
- Current organization (HMMWV based)
  - Updated organization (Interim Armored Vehicle based)
  - Interim Brigade Combat Team (Interim Armored Vehicle based).
- The analysis utilized two scenarios; a zone reconnaissance and a moving flank guard on Eastern European terrain set in the 2004 time frame.

### 2. (U) ANALYSIS ISSUES

- 2.1 (U) The Blue Ribbon Panel directed the analysis of the following two issues.
- **Can the Interim Cavalry Regiment (ICR) organizational structure and weapon systems mix effectively support corps or joint/combined task force (JTF/CTF) operations? [2ACR vs. 2ICR vs. IBCT]**
  - **What is the operational effectiveness impact of three versus four MGS vehicles per platoon in the ICR?**
- 2.2 (U) This report will consider each of these two issues separately. Each of the issues employed a different scenario and a different set of measures of effectiveness (MOE) and measures of performance (MOP).

3. (U) STUDY ISSUE 1. The intent of the analysis was to compare the force effectiveness of the alternative organizational structures in a zone reconnaissance scenario set in Eastern Europe in 2004.

3.1 (U) Alternative Structures. The analysis of study issue 1 examined three alternative force structures. These alternative force structures are as follows.

3.1.1 (U) Current 2<sup>nd</sup> Armored Cavalry Regiment force structure is displayed in figure 1. The primary platform for this alternative is the HMMWV.

UNCLASSIFIED

### 2ACR Organization Chart

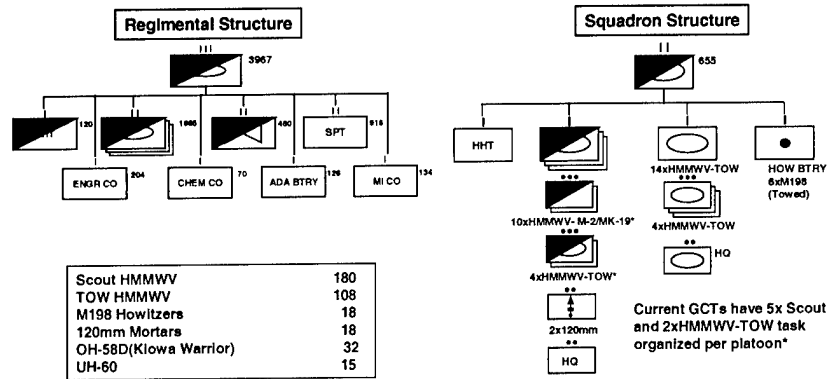

Figure 1. (U) Current 2<sup>nd</sup> ACR Organization

3.1.2 (U) The second alternative force structure examined was the interim cavalry regiment shown in figure 2. This alternative was the result of the Blue Ribbon Panel discussions. The force structure is interim armored vehicle based.

UNCLASSIFIED

### 2ICR Organization Chart

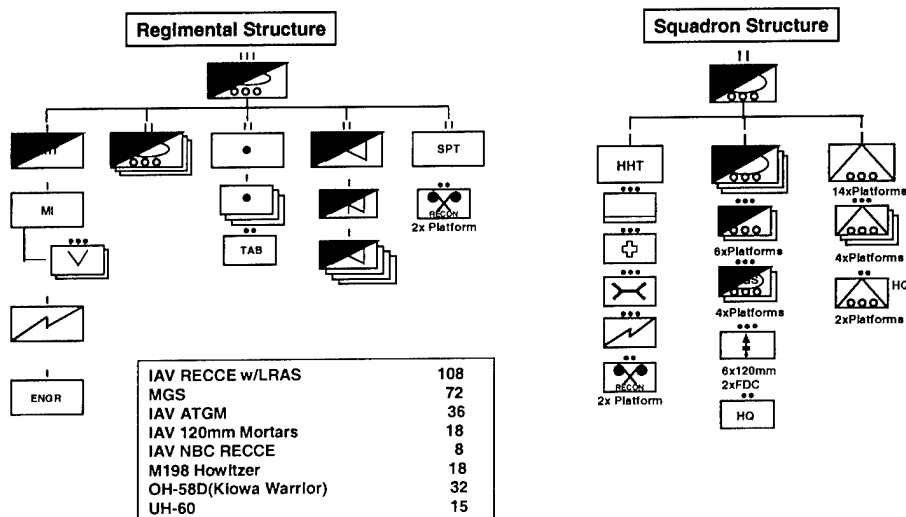
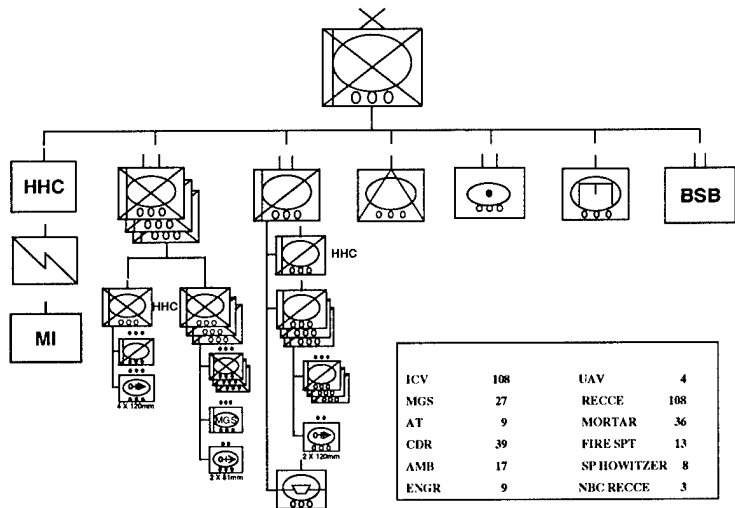

Figure 2. (U) Interim Cavalry Organization

3.1.3 (U) The third and final alternative force structure examined was the interim brigade combat team. This unit unlike the other two is not a cavalry organization. This unit is an infantry centric organization equipped with interim armored vehicles. It is displayed in figure 3 below.

UNCLASSIFIED

**IBCT Organization Chart**



**Figure 3. (U) Interim Brigade Combat Team**

3.2 (U) Scenario. The terrain for the scenario was set in Eastern Europe. The fictional setting of the scenario is depicted in figure 4. This displays the boundaries of the countries after the breakup of the Pozard Republic in the early 1990's. The small green dotted box in the country of Ozul is the terrain box where the simulation takes place.

UNCLASSIFIED

UNCLASSIFIED

## Scenario Setting

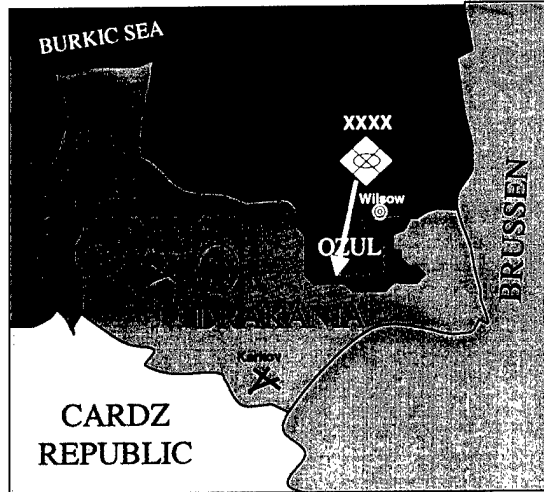

Figure 4. (U) Scenario Setting

3.2.1 (U) The events that led to the involvement of U.S. forces in this conflict are shown in figures 5 and 6 below. Figure 5 depicts the long term (1990-2002) events that generally shaped the coalitions in the area. Figure 6 shows the short term (2003-2004) events leading up to the commitment of U.S. forces.

## Road to War (Part 1)

<ul style="list-style-type: none"> <li>• The swift collapse of the Pozard Republic in 1991 was followed by destructive warfare, destabilization of boundaries, and renewed ethnic conflict.</li> <li>• Ozul, an autonomous province in northern Drakania, a former part of the Pozard Republic, contained a mixed population. The majority of the population consisted of ethnic Pozardians (55%), while the minority consisted of ethnic Ozulians (30%) and Drakanians (15%).</li> <li>• The Pozardian President altered the status of Ozul, removing its autonomy and bringing it under his direct control. The Ozulians strenuously opposed the move.</li> <li>• During 1998, open conflict between Pozardian forces and Ozulian Liberation Fighters (OLF) resulted in the deaths of over 1,500 Ozulians and forced 400,000 people from their homes.</li> <li>• In March 1999, an Ozulian delegation signed a U.N.-proposed peace agreement, but talks broke without a signature from the Pozardian delegation.</li> <li>• Following the collapse of the negotiations, Pozard introduced additional forces into Ozul that terrorized resident Ozulians and Drakanians. In May 1999, a NATO campaign forced the withdrawal of Pozardian forces, allowing for the introduction of NATO peacekeeping forces.</li> </ul>	<ul style="list-style-type: none"> <li>• Lingering conflict between the three ethnic populations in Ozul abated in 1999 and in March 2000, Ozul declared independence. Pozard had no response to the independence declaration.</li> <li>• In October 2000, the UN implemented a democratic elections monitoring program that apparently solidified Ozul's move for independence.</li> <li>• In April 2002, the U.S. began training the former OLF, now known as the Ozulian Protection Corps (OPC), as a defense force.</li> <li>• By March 2002, NATO peacekeeping forces withdrew from Ozul. Only a small U.N. observer mission replaced the NATO forces. Monitored by U.S. intelligence, who retained interest in Pozardian activities, the 1st Pozardian Army conducted its regularly scheduled FTX near the Ozulian border.</li> <li>• In May of 2002, ethnic Ozulians and Drakanians in Ozul, led by the recidivistic OPC, begin retaliatory attacks on ethnic Pozardians in Ozul. The Ozulian government condemned the activities. The U.S. immediately ceased training the OPC.</li> <li>• In May 2002, a splinter group of the OPC that reassumed the use of the name, OLF, began limited cross-border incursions into pro-Ozulian areas of Pozard.</li> </ul>
---	---

Figure 5. (U) Road to War (Long Term)

## Road to War (Part 2)

<ul style="list-style-type: none"> <li>• In June 2003, the 1st Pozardian Army conducted a CPX, instead of its customary FTX, with its known organic units.</li> <li>• In October 2003, the 1st Pozardian Army conducted a CPX, and U.S. intel sources detected the participation of four additional entities (assumed to be Division HQs) in the CPX.</li> <li>• In November 2003, the Pozard Republic requested, but did not receive, U.N. support in stopping OPC and OLF activities. With growing national support for stopping the two Ozulian groups, Pozard began infiltrating unconventional units into Ozul to protect ethnic Pozardians.</li> <li>• In January 2004, Pozard moved conventional forces to counter especially aggressive OLF operations north of Wilsow while also moving conventional forces to its southern border to contain increasingly vicious OPC activities along the narrow Telszen peninsula between Pozard and Ozul.</li> <li>• In February 2004, right-wing ethnic Pozardians in Ozul, estimated to number 800 personnel, set off explosions in a number of towns in Ozul, destroyed government buildings in the eastern town of Prima, and conducted a mortar attack on the Prima airport.</li> <li>• The OPC responded to the Pozardian attacks by murdering 37 ethnic Pozardians in the town of Lutz. Civil unrest was heightened by the escalating conflict.</li> </ul>	<ul style="list-style-type: none"> <li>• On 2 February 2004, Pozard conducted an FTX, confirming the inclusion of the four additional Divisions in 1st Pozardian Army.</li> <li>• On 10 February 2004, Pozardian conventional units crossed into Ozul and following four days of fighting penetrated south establishing its historic border with Drakania. Ethnic Ozulians and Drakanians were forced to displace into Drakania.</li> <li>• On 16 February 2004, displaced Ozulians petitioned the U.N. for immediate assistance in eliminating the conventional occupation forces, and reestablishing the nation of Ozul.</li> <li>• Between 16 February and 30 March 2004, the U.S. executed a series of FDOs for deployment to Wroclaw and Karkov.</li> <li>• 16 February 2ICR begins deployment to Drakania by air along with an Airborne Corps.</li> <li>• 20 February, an air and missile campaign begins against Pozardian conventional forces operating within Ozul.</li> <li>• 7 March 2004, Pozardian occupation forces faced with the deployment of one US Corps, one multinational Corps and the continuing air and missile campaign, begin to establish a web-based defense along the Drakanian border.</li> </ul>
--	---

Figure 6. (U) Road to War (Short Term)



UNCLASSIFIED

3.2.6 (U) The portion of the Regiment that was simulated and their scheme of maneuver for both the current force structure and the interim cavalry regiment is displayed in figure 8.

UNCLASSIFIED

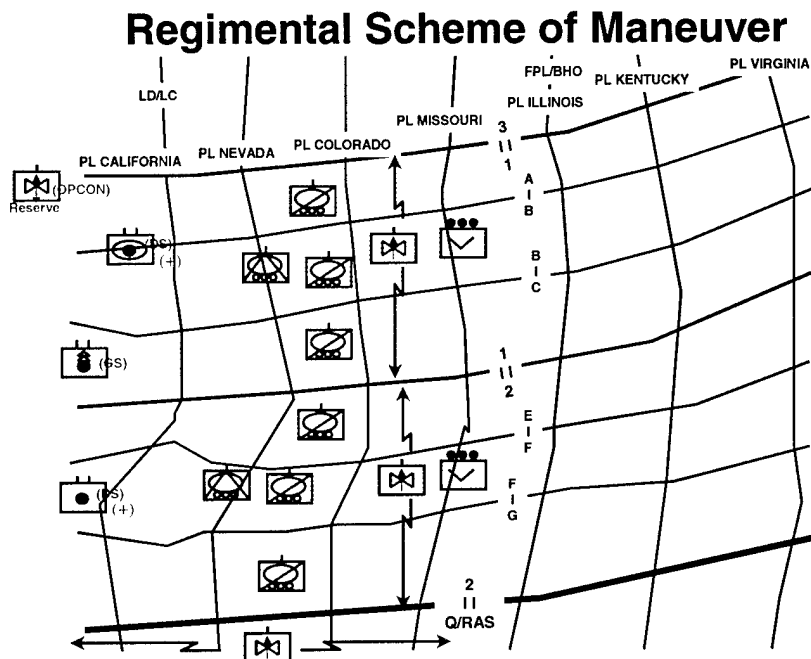
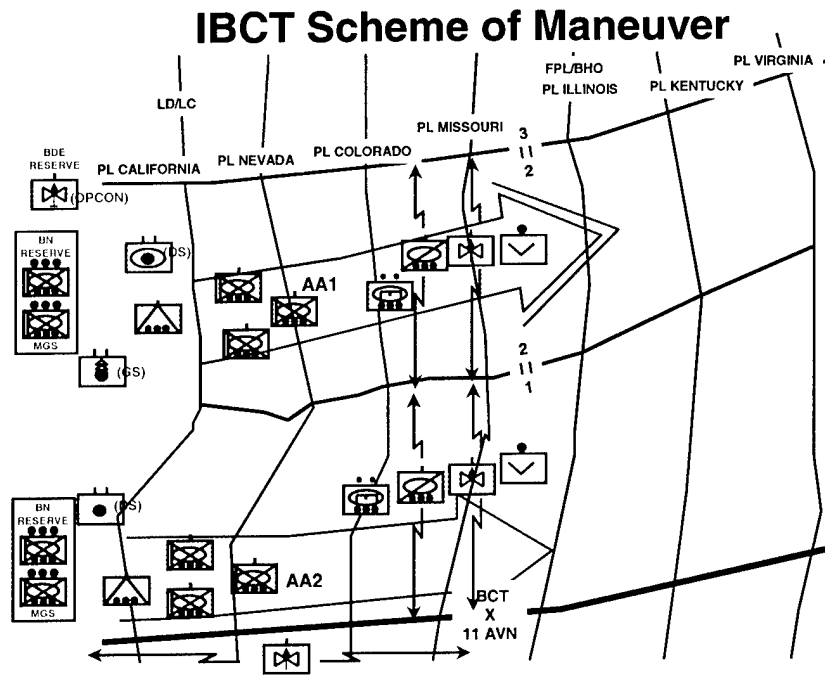

Figure 8. (U) Regimental Scheme of Maneuver

3.2.7 (U) The maneuver of the interim brigade combat team was different than the other two force alternatives. It was the position of the Infantry Center that the IBCT was unable to completely cover the zone and would only concentrate on two possible Corps axes of attack. The northernmost was the primary effort based on the mission and the initial information available. The mission and intent were the same for the IBCT as the other two alternatives. The endstate of the IBCT added the endstate criteria of at least 75% of the Infantry platoons surviving in addition to the 70% survivability of combat power. The scheme of maneuver for the IBCT is shown in figure 9.

UNCLASSIFIED



**Figure 9. (U) IBCT Maneuver Scheme**

3.2.8 (U) Threat intentions and method of employment were greatly influenced by a TRADOC Deputy Chief of Staff for Intelligence Operational Environment White Paper during this scenario. The Threat employed what is known as a web-based defense throughout the width and breadth of the occupied territory. In this defense, Threat forces remain connected via various communications means but seek safety inside cities and built-up areas. Threat forces sought to fight only when they perceived an advantage or were forced. They preferred to attack Combat Support and Combat Service Support assets when they could.

3.2.9 (U) The Threat force mission was to screen the division's Western flank to allow the withdrawal of forces north to Pozard. The Threat commander's intent was to allow forces to conduct a withdrawal out of contact of U.S. ground forces. This was to be accomplished by developing an integrated web-based system of defensive positions throughout the depth of our sector oriented on the enemy's likely axis of attack. The Threat sought to negate the enemy's strengths by staging forces in built-up areas and deploying them only when necessary. The intent is to defeat enemy reconnaissance echelons and delay and attrit main body forces. Critical to the mission are the maintenance of communications, a robust air defense structure and the integration of artillery fires throughout the sector.

3.2.10 (U) The endstate sought by the Threat was no penetration of the sector by enemy forces for 24 hours, the infliction of a high level of casualties on the attacking forces and the majority of the Threat combat power in strongpoints throughout the sector.

3.2.11 (U) The initial Threat laydown of the brigade (+) is shown in figure 10.

UNCLASSIFIED

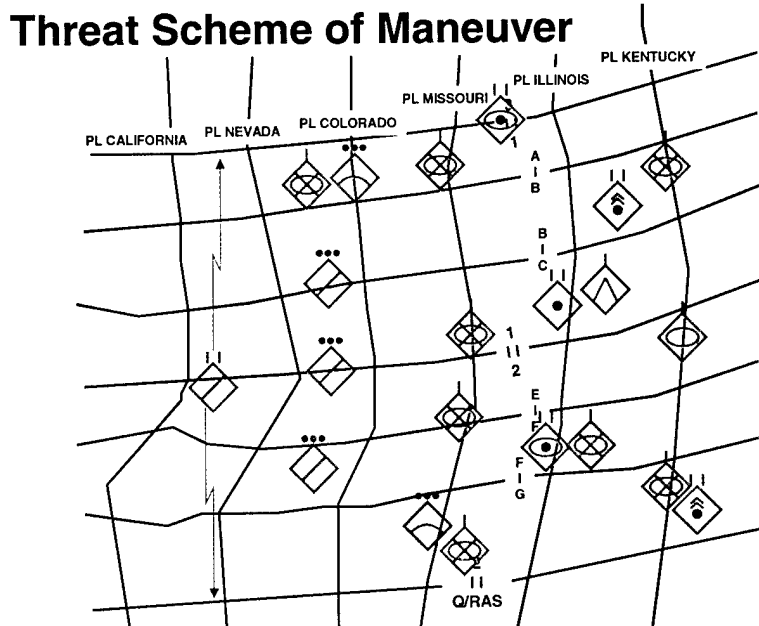

Figure 10. (U) Initial Threat Laydown

3.3 (U) Assumptions. A number of key assumptions were made concerning this scenario. These are shown in figure 11. Figure 12 displays the modeling assumptions that were made during the Janus simulation.

UNCLASSIFIED

### Key Assumptions

- ✓ Timeframe - Spring 2004
- ✓ NCA/CINC directs deployment of an Airborne Corps including its assigned Cavalry Regiment
- ✓ Deployment of Blue forces is unopposed
- ✓ An air and missile campaign has attrited threat forces
- ✓ We have air superiority, however the Airborne Corps is not the main effort
- ✓ The enemy will not use NBC weapons
- ✓ The local populace is tolerant of occupying threat forces due to ethnic ties
- ✓ Enemy tactics and objectives are consistent with the DCS-INT Operational Environment White Paper

Figure 11. (U) Key Scenario Assumptions

UNCLASSIFIED

## Key Assumptions (Modeling)

- ✓ To limit the variability in the model and to allow analysis, the following assumptions were implemented:
- ✓ CAS or ATK fixed wing aircraft were not used
- ✓ Strategic or national intelligence feeds were not forwarded during this mission
- ✓ HUMINT personnel were not modeled
- ✓ Civilians on the battlefield were not modeled
- ✓ The urban areas added were reasonable and consistent with the 1:50,000 map sheets
- ✓ "Best Available" data was used
- ✓ All Blue units would have access to the technical ISR provided by the echelons above the Regiment
- ✓ Endstate criteria is the Regiment reaching PL Illinois or 70% combat power remaining; for the IBCT - 75% of Infantry squads remaining

Figure 12. (U) Modeling Assumptions

3.4 (U) Analysis. The analysis for study issue 1 was examined for the following areas:

- Provides Relevant Information
- Movement Facilitation
- Exchange Ratios
- Survivability
- Armor Defeating Capability

These areas were identified as the essential elements of analysis (EEA) for this study issue. Under each of these EEA one or more measures of effectiveness (MOE) or measures of performance (MOP) were examined.

3.4.1 (U) Provides Relevant Information. Under this element of analysis the measure of performance examined was the number of Threat high payoff targets detected. Detection of these high payoff targets enabled the friendly force to target them with artillery, thereby, reducing the need to attack them directly. As shown in figure 13, the ICR and IBCT outperformed the current ACR force structure in detecting these targets. The ICR and IBCT were particularly better at detecting the anti-tank (AT) and air defense artillery (ADA) targets. Note the highlighted portions of figure 13. These targets could be detected more easily by the ICR and IBCT due to the depth each penetrated into the zone and the speed with which they penetrated the zone. The IBCT detected more towed artillery and tanks than the ICR due to the Threat not retrograding this equipment in response to the tactical situation as was done in the ICR simulations.

UNCLASSIFIED

Provides Relevant Information

% of Threat High Payoff Targets Detected

	IFV			AT			Other	ADA			FA				AR				
	BFM1K	BTTR00K	BMP2M	20MM RM	B2 RECOL	TOPALZ	BOV1AT	REMBASS	MTLB	SA15	SA13	236	2323	2S19	M77-12	M87-28	M84	T72M1R	TOTAL
ACR	53	16	44	7	0	21	0	12	19	0	0	0	50	100	0	0	0	5	24.7
IBCT	51	22	52	19	11	50	44	58	22	67	50	25	58	100	0	0	61*	42*	37
ICR	47	24	26	26	6	46	51	22	27	44	42	25	92	100	11	0	22	3	37

\* Threat Did Not Retrograde

Figure 13. (U) Detection of High Payoff Targets

3.4.2 (U) Movement Facilitation. Within this element of analysis, the mission accomplishment, the number of detections and the percentage of Threat units detected, the movement rate, and the time required to reach endstate of each of the force structures were examined. All of these measures of performance were gathered and portrayed on a single figure for each of the alternatives. Figures 14 through 16 portray these measures for the ACR, ICR and IBCT respectively. The analysis of these measures will follow the figures.

### ACR's Movement Facilitation

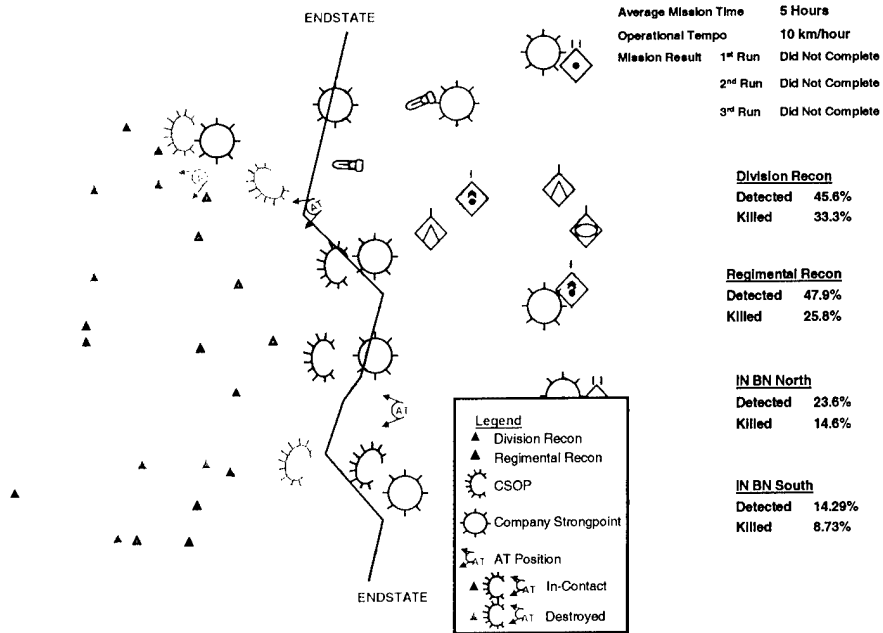

Figure 14. (U) ACR's Movement Facilitation

### ICR's Movement Facilitation

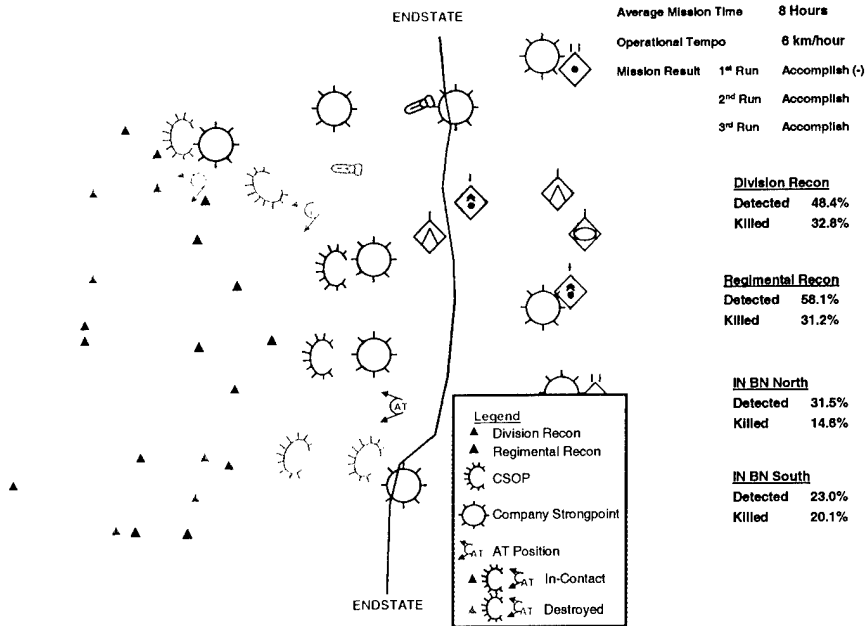

Figure 15. (U) ICR's Movement Facilitation

### IBCT's Movement Facilitation

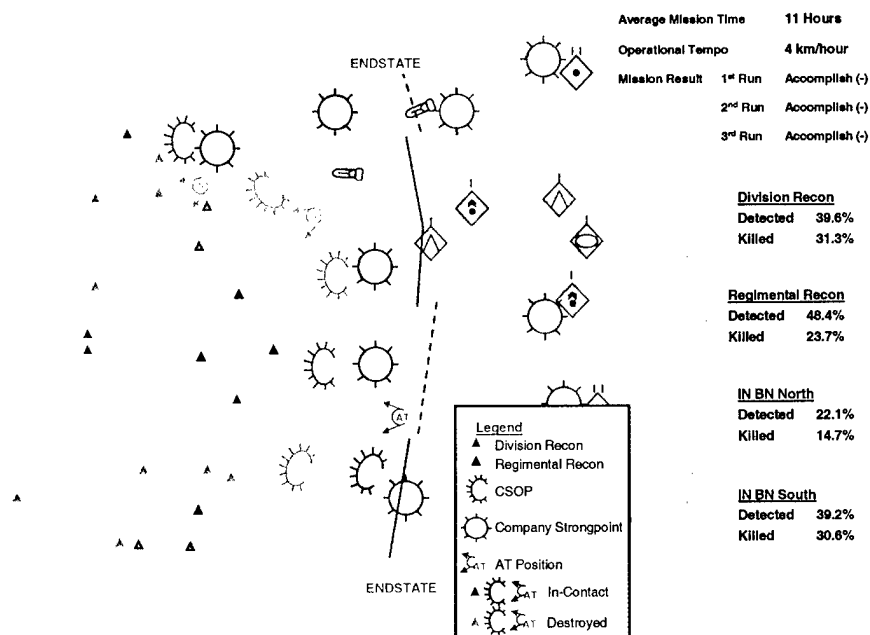

Figure 16. (U) IBCT's Movement Facilitation

3.4.3 (U) Mission Accomplishment. The current ACR failed to accomplish the mission of reaching PL Illinois with at least 70% of its combat power on any occasion. The current force structure based on the HMMWV did not permit the force to survive and destroy the enemy outposts as called for in the mission. The ICR accomplished the mission on all occasions. On one occasion the unit was not covering all of PL Illinois and therefore was rated as accomplish(-). The IBCT because of its inability to fully cover all portions of PL Illinois due to its actions to only clear two axes was rated accomplish(-) on all three occasions. The survivability of the IAV and the replacement of the HMMWV TOW with the MGS were the primary contributors to the increased mission accomplishment for the ICR and IBCT. The additional dismounts that were available with the IAV also allowed for development of the situation quicker, especially in close terrain. The canister round employed by the MGS enabled the clearing of Threat combat outposts much quicker and with fewer casualties.

3.4.4 (U) Threat Detection by Unit. The current ACR force structure detected nearly 46% of the Threat Division reconnaissance force. The IAV equipped ICR force detected 48% of the Threat Division reconnaissance force. The IBCT force detected nearly 40% of the same Threat force. The Threat division reconnaissance force was the most forward deployed and thus the closest Threat force to PL California. Therefore, each alternative detected a large number of this Threat force. The same is also true of the Threat Regimental reconnaissance force. The ACR and IBCT both detected 48%, the ICR detected 58% of this Threat force. The IBCT detected the fewest of these forces because the reconnaissance, surveillance and target acquisition (RSTA) squadron found it difficult to perform the zone reconnaissance over the 30-kilometer frontage required. The RSTA squadron was reluctant to move out from under their artillery umbrella and forfeit the

## UNCLASSIFIED

indirect fires. The RSTA troops were forced to halt when they lost the majority of their dismounts and lost the support of unmanned aerial vehicles and helicopters due to the increasing air defense threat to the East. The major differences in Threat detection by unit occurred when the Threat Infantry battalions are examined. For the Threat Infantry battalion in the North, the ACR detected approximately 24%, while the ICR detected nearly 32% and the IBCT detected only 22%. The ACR was not able to perform reconnaissance against this force especially in Alpha and Bravo Troop sectors. Even though the IBCT designated the Northern axis as its main effort they bypassed significant Threat forces especially in the Northern part of the sector. The ACR detected only 14% of the Threat Infantry battalion in the South. The ICR detected 23% and the IBCT detected 39% of this Threat force respectively. The increased survivability of the IAV equipped forces enabled the IAV equipped forces to progress further into the enemy's defense in the Southern sector.

3.4.5 (U) Threat Killed by Unit. Examination of the same Threat forces namely, division reconnaissance, regiment reconnaissance and two infantry battalions, for percentage killed yields smaller numbers than detections. This is logical since not all detected forces are engaged and therefore cannot be killed. The ICR killed 5-7% more of the regimental reconnaissance force than the ACR and IBCT. The Southern Infantry battalion suffered 9%, 20% and 31% casualties at the hand of the ACR, ICR and IBCT force respectively. All other percentages of Threat force killed are nearly the same for all alternative forces. The reasons for these increases can be traced to the increased survivability of the IAV equipped forces. Additionally, the Threat force did not retrograde as many systems in the South when opposed by the IBCT force, again in response to the tactical situation.

3.4.6 (U) Movement Rate. The average mission time, or time to reach endstate, for the ACR was five hours of simulation time. However, this force did not perform the mission completely to PL Illinois. The movement rate was calculated at 10 kilometers per hour. This was accomplished against the widely dispersed Threat reconnaissance forces mostly. The ICR accomplished the full mission in an average mission time of eight hours that translates to approximately 6 kilometers per hour. The IBCT force likewise completed the movement to PL Illinois in an average of 11 hours. This translates to a movement rate of approximately 4 kilometers per hour. The ACR therefore moved through the widely dispersed Threat sector at a fairly rapid pace but could not keep up the momentum when opposed by the Infantry battalions and the unmanned aerial vehicles and scout helicopters were unable to continue to move ahead of the force due to the ADA threat. The ICR accomplished the mission against the same Threat laydown by dismounting troops and developing the situation and bringing the MGS forward to support these tactical maneuvers. The IBCT was also able to effectively clear two axes of advance for the corps but took 40% longer to do the mission due to the reliance on the Infantry centric forces.

3.4.7 (U) Force Ratio. The measure of effectiveness chosen for this element of analysis is Force Exchange Ratio (FER). FER is defined as the Loss Exchange Ratio (LER) divided by the Initial Force Ratio (IFR). FER was chosen as the measure of force effectiveness due to the unequal starting or initial number of systems in the alternative force structure. This measure of effectiveness normalizes these unequal starting numbers. The minimum, maximum and average force exchange ratio for each of the alternatives is displayed in figure 17. A statistical analysis of the pairings of FER shows

# UNCLASSIFIED

the ICR and IBCT averages are both different from the ACR. There is no statistical difference between the ICR and IBCT average FER. It should be noted that from an attrition standpoint none of the alternative force structures is succeeding as is evident by examining the FER.

UNCLASSIFIED

## Exchange Ratios

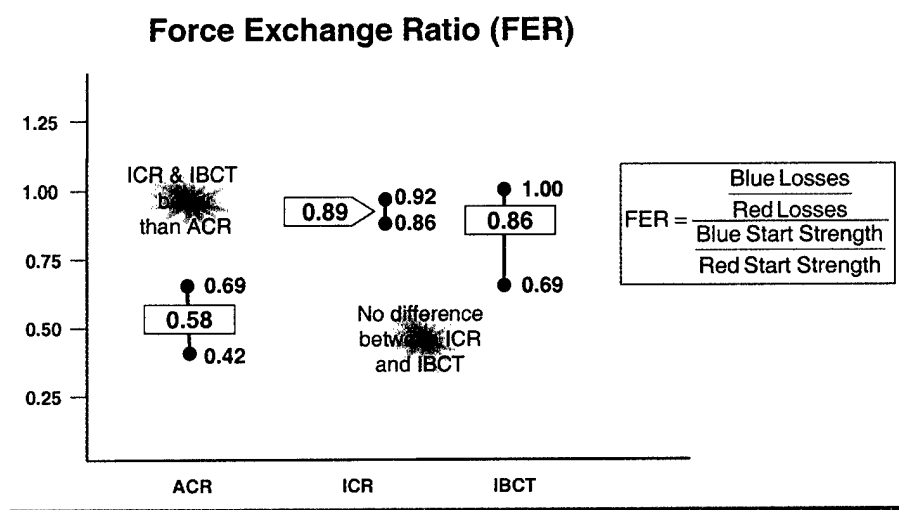

Figure 17. (U) Force Exchange Ratio Comparison

3.4.8 (U) Survivability. Shown in figure 18 is the percentage of scout vehicles, MGS/AT vehicles and infantry squad equivalents (nine men/squad) remaining at the endstate on average. Shown in the middle of each bar is the total remaining number over the starting number for each category. This shows that there is not a great deal of difference in combat power remaining for any of the three alternative force structures. This should not be surprising since the rule used to arrive at endstate was completion of mission or 70% strength. The ACR was not able to complete the mission so the gaming was ended when they reached 70% of beginning combat power. Had the ACR attempted to continue on to PL Illinois it undoubtedly would not have survived as well as the other alternative force structures. Even when the other alternatives completed the mission, the status of combat power was very nearly 70% strength anyway. The IBCT was approaching the additional endstate criteria of 75% strength of its infantry squads. The Infantry School developed this criterion because the infantry centric IBCT force was primarily dismounted and the combat vehicles were hardly ever leading the friendly formation.

UNCLASSIFIED

### Survivability

Combat Power Remaining at Endstate

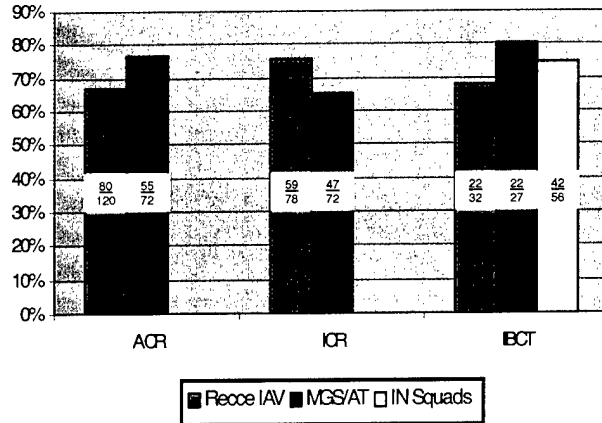

Figure 18. (U) Survivability Comparison

3.4.9 (U) Armor Defeating Capability. Figure 19 displays the number of light and heavy armor systems that were killed by each of the alternative force structures. Overall the ICR and IBCT averaged 20% more kills than the ACR force structure. The ICR does slightly better at killing the light armor BTR and MTLB than either of the other alternatives. The IBCT was the only force structure that detected and killed the T72 tanks. This was again due to the Threat not retrograding these systems as had been done in the ACR and ICR case.

UNCLASSIFIED

## Armor Defeating Capability

### Threat losses to Blue Systems

Threat Losses	ACR		ICR		IBCT	
	Total	Kill Range (m)	Total	Kill Range (m)	Total	Kill Range (m)
BRM1K	8	1,544	5	1,991	7	1,821
BTR80K	13	1,247	19	956	15	1,191
BMP2M	2	726	2	1,514	3	956
BOV1AT	0	---	2	2,022	0	---
MTLB	9	2,606	13	2,768	10	2,954
2S19	7	2,416	7	2,461	10	1,594
T72M1R	0	---	0	---	4	722
Total	39		48		49	

Figure 19. (U) Armor Defeating Capability

3.5 (U) Conclusions. The conclusions to be drawn from the analysis of the first issue are many indeed. However, the important conclusions are shown in figure 20. These conclusions are grouped by the essential elements of analysis. They lead to the basic conclusion that the IAV equipped units (i.e., ICR and IBCT) perform the mission better than the current 2<sup>nd</sup> Armored Cavalry Regiment. The ICR performs the mission in less time and with less risk than the IBCT.

UNCLASSIFIED

## Conclusions

- ✓ Relevant Information
  - ✓ ICR & IBCT consistently detected a higher percentage of Threat high payoff targets than the ACR (ADA detections were significantly higher)
- ✓ Movement Facilitation
  - ✓ ICR & IBCT detected and killed a larger percentage of the Threat Infantry battalions
  - ✓ ACR failed to complete the mission before being attrited
  - ✓ ICR completed the mission in less time than the IBCT
- ✓ Exchange Ratio
  - ✓ ICR & IBCT Force Exchange Ratio (FER) statistically significant when compared to ACR
  - ✓ No statistically significant difference between ICR and IBCT FER
- ✓ Survivability
  - ✓ ACR had to cease operations before mission completion due to lack of survivability
  - ✓ IBCT success dependent upon dismounted force survivability rather than vehicle
- ✓ Armor Defeating Capability
  - ✓ Addition of MGS and additional dismounted personnel added to the armor defeating capability of the ICR & IBCT

Figure 20. (U) Issue 1 Conclusions

4. (U) STUDY ISSUE 2. The intent of the analysis was to compare the force effectiveness of the alternative MGS platoon structures in a moving flank guard scenario set in Eastern Europe in 2004.

4.1 (U) Alternative Structures. The analysis of study issue 2 examined two alternative platoon structures. These alternative force structures are as shown in figure 21. The only difference is the number of MGS in a platoon. The number of MGS varies between 72 per squadron (4 MGS per platoon) and 54 per squadron (3 MGS per platoon). The number of all other systems remained the same for each of the alternative force structures.

### Alternative Force Structures

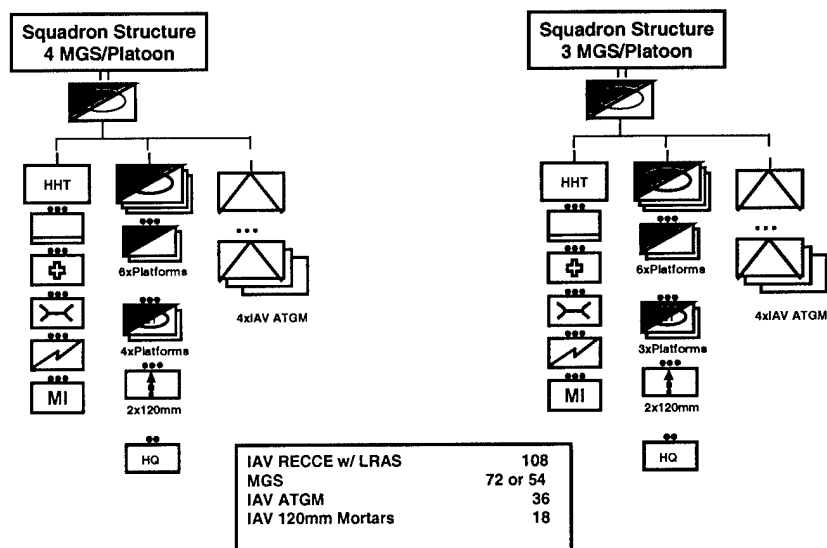
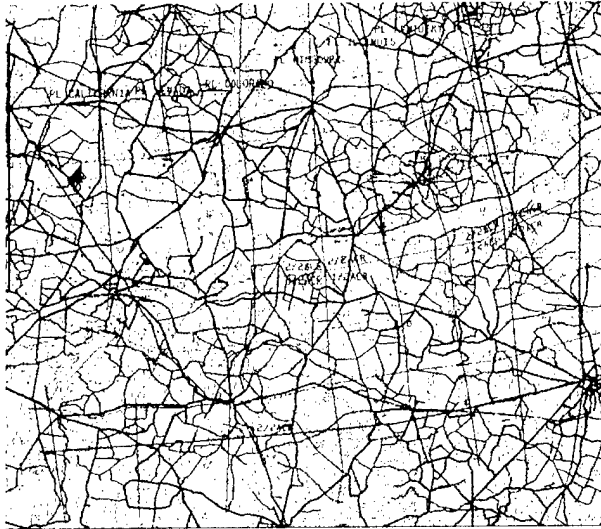

Figure 21. (U) MGS Platoon Alternative Force Structures

4.2 (U) Scenario. The terrain for the scenario was the same as that employed in examination of issue 1. The terrain was set in Eastern Europe. The fictional setting of the scenario is depicted in figure 4. This displays the boundaries of the countries after the breakup of the Pozard Republic in the early 1990's. The small green dotted box in the country of Ozul is the terrain box where the simulation takes place. The events that led to the involvement of U.S. forces in this conflict are shown in figures 5 and 6 above. Figure 5 depicts the long term (1990-2002) events that generally shaped the coalitions in the area. Figure 6 shows the short term (2003-2004) events leading up to the commitment of U.S. forces. Figure 22 displays the terrain box where the simulation took place for this scenario. Notice it is a subset of the maneuver area used in the zone reconnaissance scenario for issue 1. Also displayed are the friendly control measures that were in place for the MGS platoon alternatives. Note the squadron zone is approximately 30 kilometers wide. The troop zones vary between 8 and 11 kilometers in width.

## Maneuver Box



**Figure 22. (U) Flank Guard Maneuver Area**

4.2.1 (U) The mission for the friendly force was to conduct a flank guard along the corps Southern boundary in order to protect the Corps mainbody from surprise and early deployment. On order, each Squadron was to establish a screen along PL Lead and trade space for time through PL Copper and PL Brass with a no penetration line of PL Silver to protect the Corps mainbody and allow them to continue the attack. The graphics for this mission are displayed in figure 23 below.

4.2.2 (U) The intent of the operation is to protect the Corps mainbody from attack. Critical tasks for this mission are the destruction of enemy attacking forces, and protection of Corps mainbody flank by denying Threat platoon sized elements from crossing PL Silver.

4.2.3 (U) Desired endstate for this mission is the Squadron guarding along PL Silver having defeated the Threat Regiment to less than 70% combat power and the Corps mainbody movement without delay or commitment.

UNCLASSIFIED

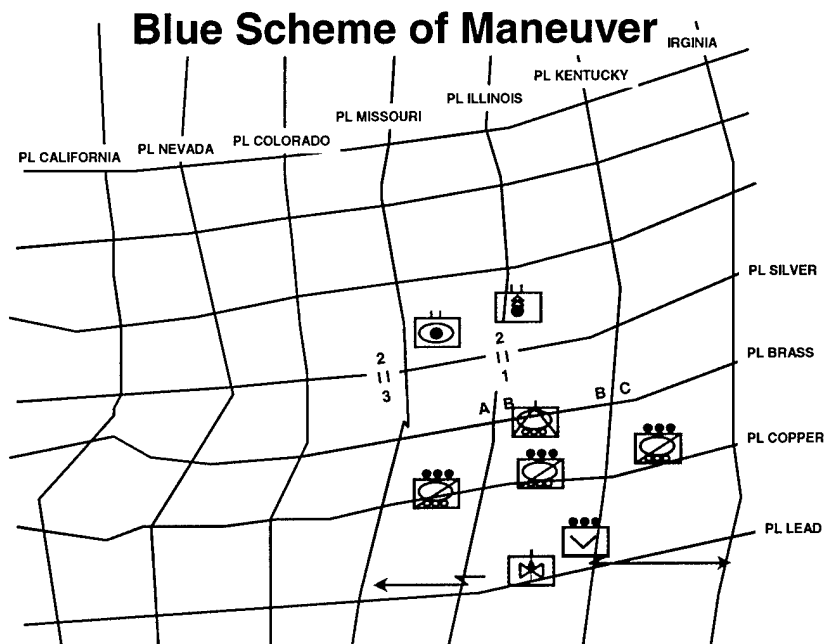
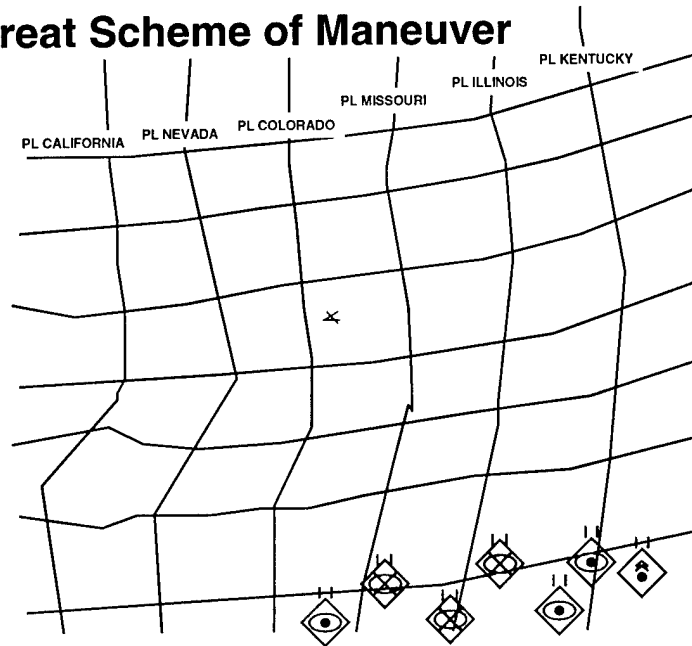

**Figure 23. (U) Friendly Scheme of Maneuver**

4.2.4 (U) The Threat upon recognizing a Blue weakness was to send a regimental counterattack into the Blue flank and seize the airfield vicinity of PL Colorado. The intent of the counterattacking Threat force was to disrupt the forward movement of the U.S. Corps by destroying a forward air resupply point and any aircraft staging out of this site. The critical tasks associated with this mission were to maintain communications and a robust air defense with integrated artillery fires throughout the sector. The endstate sought by the Threat force was penetration of the flank guard forces, destruction of the forward area refueling point (FARP), high infliction of casualties and then a rapid withdrawal and resumption of the web-based defense. The threat laydown is portrayed in figure 24.

UNCLASSIFIED

## Threat Scheme of Maneuver



**Figure 24. (U) Threat Scheme of Maneuver**

4.3 (U) Assumptions. The assumptions made were the same for issue 2 as those portrayed in figure 11 above. The modeling assumptions were the same as those displayed in figure 12 with the exception of the endstate criteria. The endstate criteria for this scenario is the penetration of PL Silver by a Threat element platoon-size or larger or friendly forces having 70 percent of its combat power remaining.

4.4 (U) Analysis. The analysis for study issue 2 was examined for the following areas:

- Mission Accomplishment
- Exchange Ratios
- Survivability
- Armor Defeating Capability

These areas were identified as the essential elements of analysis (EEA) for this study issue. Under each of these EEA one or more measures of effectiveness (MOE) or measures of performance (MOP) were examined.

4.4.1 (U) Mission Accomplishment. Analysis of the mission accomplishment analysis element examined the ability of the alternative platoon sized structures to deny the Threat force penetration. As shown in figure 25, the three MGS platoon force was able to accomplish this task only once and then it was marginally combat effective. The four MGS platoon force accomplished the mission two out of three attempts. The four MGS platoon possessed greater flexibility than the three MGS platoon. This increased flexibility was evident in the platoon's ability to displace while providing its own security, the ability of the commander to position sections to cover a larger area and/or in greater depth and to maneuver sections once the Threat intention was determined. The four MGS platoon covered a wider frontage due to the deployment of MGS sections of two where the three MGS platoon was only able to occupy a single position.

**UNCLASSIFIED**

Displacement of the three MGS platoon was more difficult due to one vehicle being assigned to cover the movement of the other two MGS.

**UNCLASSIFIED**

**Mission Accomplishment**

<b>Mission Result</b>		
	<b>3 MGS</b>	<b>4 MGS</b>
<b>Run #</b>		
1	Accomplish (-)	Accomplish
2	Did Not Complete	Accomplish
3	Did Not Complete	Did Not Complete

**Figure 25. (U) Mission Accomplishment Comparison**

4.4.2 (U) Force Ratios. This analysis element was examined using the Force Exchange Ratio (FER) and the System Exchange Ratio (SER). Both of these ratios are measures of effectiveness. The Force Exchange Ratio was defined and used in the analysis of issue 1 and will not be further defined here. The minimum, maximum and average FER for this analysis is shown in figure 26. The maximum FER for the three MGS case may be an anomaly. Additional iterations of this alternative were not conducted due to time constraints but it does not have an affect on the FER statistical comparison that shows the two cases are not statistically different. The other measure of effectiveness that was used in the analysis is System Exchange Ratio. The System Exchange Ratio is a measure of the contribution of a specific system to the force effectiveness. In this case we examined the contribution of the MGS to force effectiveness. It is defined as the number of Threat systems killed by MGS divided by the number of MGS systems killed by the Threat. Examination of the SER shows the three MGS case achieved a greater SER than the four MGS case. This is shown graphically in figure 27. However, statistical analysis shows there to be no statistical difference between the two cases. The increase in SER for the 3 MGS per platoon is attributed to the tendency of these platoons to become decisively engaged by the Threat forward causing expenditure of ammunition and the reluctance to displace to subsequent positions. This caused them to exchange at a higher rate but it didn't necessarily contribute to mission accomplishment.

### Exchange Ratios

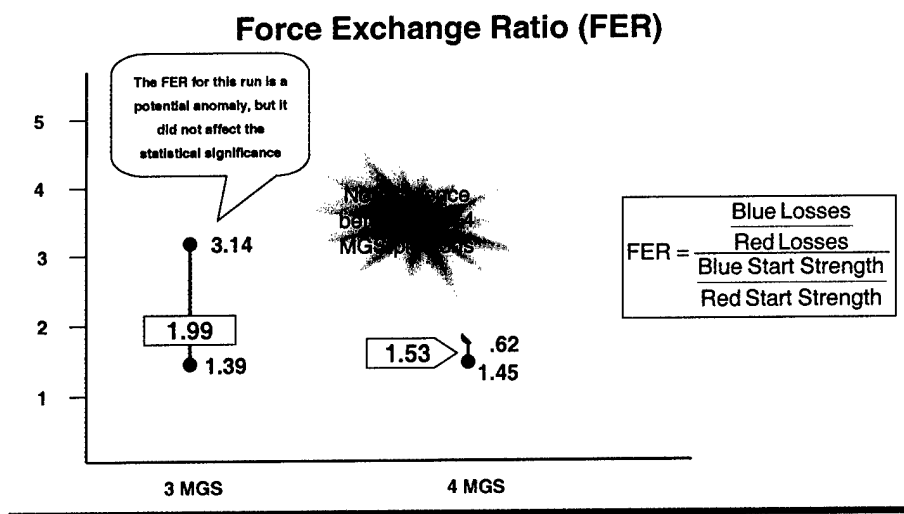

Figure 26. (U) Force Exchange Ratio Comparison

### Exchange Ratios

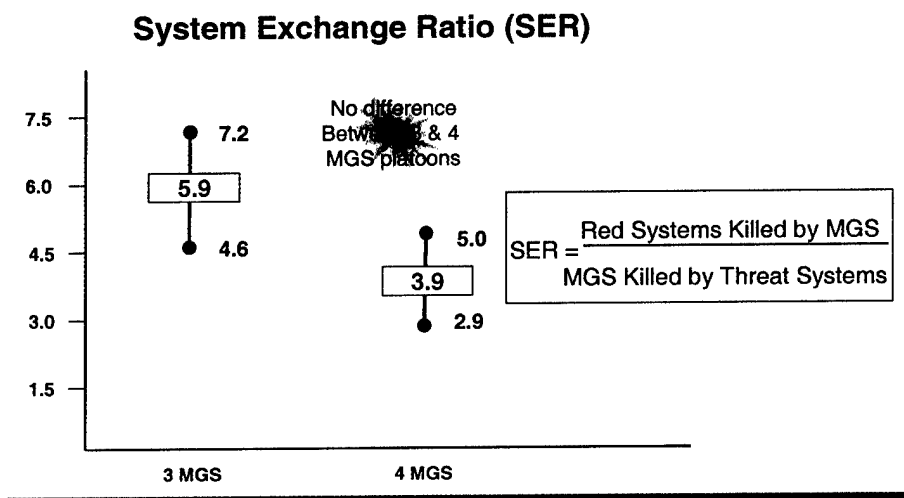

Figure 27. (U) System Exchange Ratio Comparison

## UNCLASSIFIED

4.4.3 (U) Survivability. Shown in figure 28 is the percentage of scout vehicles, MGS and AT vehicles remaining at the endstate on average. Shown in the middle of each bar is the total remaining number over the starting number for each category. This shows that there is not a great deal of difference in combat power remaining between the two alternative force structures. It should be noted that the MGS was the primary killing system employed by friendly forces. The MGS, therefore, suffered the most casualties in both cases. In each case the MGS suffered at least 50% losses while trying to carry out the guard mission.

UNCLASSIFIED

### Survivability

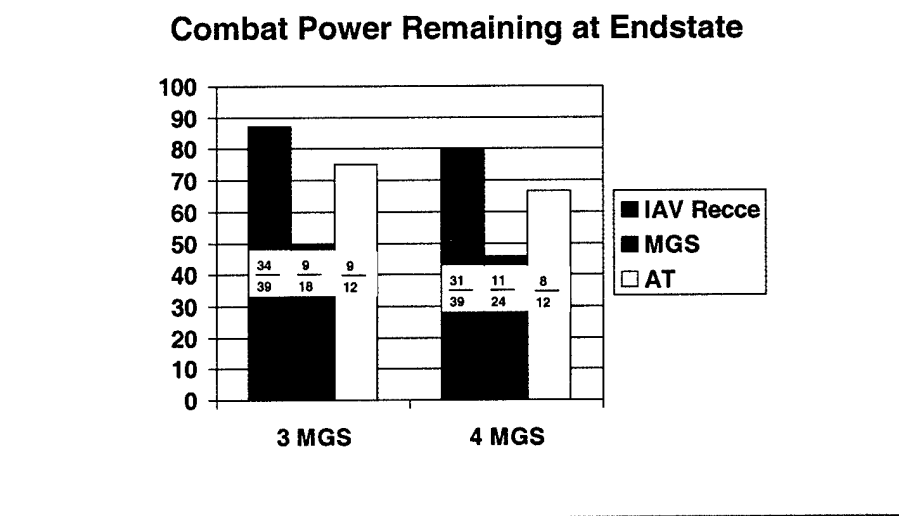

Figure 28. (U) Survivability Comparison

4.4.4 (U) Armor Defeating Capability. Figure 29 displays the number of light and heavy armor systems that were killed by each of the alternative force structures. Overall the four MGS per platoon force achieved slightly more kills than the three MGS per platoon force structure. It is important to note that the 4 MGS per platoon killed almost twice as many BMP's as the three MGS per platoon alternative. The Threat BMP's were located primarily in the second echelon battalion. This reinforces the point that the four MGS per platoon force was more flexible and able to reposition once the Threat intentions were known. The four MGS per platoon force was better able to meet the BMP battalion and attrit it compared to the other alternative force structure.

UNCLASSIFIED

## Armor Defeating Capability

### Average Threat losses to MGS

Threat Losses	3 MGS		4 MGS	
	Total	Kill Range (m)	Total	Kill Range (m)
BRM1K	1	1,687	1	1,625
BTR80K	23	2,193	21	1,957
BMP2M	5	2,032	9	2,005
BOV1AT	2	2,320	3	1,729
MTLB	4	2,009	2	1,547
T72M1R	6	2,375	7	1,536
Total	41		43	

Figure 29. (U) Armor Defeating Comparison

4.5 (U) Conclusions. The conclusions to be drawn from the analysis of the second issue are not as many as from the first issue. The important conclusions are shown in figure 30. These conclusions are grouped by the essential elements of analysis. They lead to the basic conclusion that the four MGS per platoon is the more flexible organization. The four MGS per platoon accomplishes the mission with better sector coverage and less incurred risk than the three MGS per platoon force.

UNCLASSIFIED

## Conclusions

- ✓ **Mission Accomplishment**
  - ✓ Force with 4 MGS per platoon accomplished the mission more frequently
- ✓ **Exchange Ratios**
  - ✓ No statistical difference between forces with 4 MGS and 3 MGS for Force Exchange Ratio and System Exchange Ratio
- ✓ **Survivability**
  - ✓ 3 MGS force survived slightly better than 4 MGS force
  - ✓ Both forces lost at least 50% of the MGS
- ✓ **Armor Defeating Capability**
  - ✓ Force with 4 MGS per platoon killed an average of two more Threat armored vehicles

Figure 30. (U) Issue 2 Conclusions

### 5. (U) CONCLUSIONS

5.1 (U) Study Issue 1 Conclusions. The conclusions that can be drawn from this analysis concerning the alternative force structures are as follows:

- **The ICR and IBCT detect more forces in zone than the ACR**
- **The ICR provides the supported commander with a more complete visualization of the zone than the ACR and IBCT**
- **The ICR performs the zone reconnaissance quicker than the IBCT**

5.2 (U) Study Issue 2 Conclusions. Conclusions drawn from the analysis of issue 2 concerning the size of the MGS platoon are as follows:

- **The force with 4 MGS per platoon accomplished the mission better than the 3 MGS per platoon force**
- **Once the 3 MGS platoon was engaged it was unable to disengage and maneuver**
- **The 4 MGS per platoon force killed more Threat armor systems than the 3 MGS per platoon force**

## UNCLASSIFIED

6. (U) RECOMMENDATIONS. The following recommendations are made concerning modeling and simulation of the interim cavalry regiment.

- **No more simulation be performed comparing the current ACR and the interim ICR**
- **Due to the maturation of the objective force concept, future simulation concentrate on the ICR and its subsequent variations in force structure for insights into the proper force design.**

**UNCLASSIFIED**

**UNCLASSIFIED**

**UNCLASSIFIED**

**UNCLASSIFIED**