

000530

NASA SP-5010

*f*

# TECHNOLOGY HANDBOOK

Technology Utilization Division

## (SELECTED SHOP TECHNIQUES)

*ok*

71 SELECTED SUGGESTIONS  
FOR MACHINISTS, MECHANICS,  
AND TECHNICIANS

**DISTRIBUTION STATEMENT A**  
Approved for Public Release  
Distribution Unlimited

**Reproduced From  
Best Available Copy**

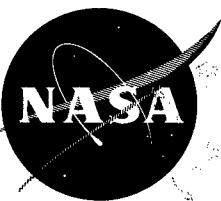

**AMPTIAC**

NATIONAL AERONAUTICS AND SPACE ADMINISTRATION

20020320 197

# TECHNOLOGY HANDBOOK <sup>7</sup>

---

Technology  
Utilization  
Division

## (SELECTED SHOP TECHNIQUES)

71 SELECTED SUGGESTIONS  
FOR MACHINISTS, MECHANICS,  
AND TECHNICIANS

<sup>5</sup>  
NATIONAL AERONAUTICS AND SPACE ADMINISTRATION

---

Washington, D. C.

August 1965

## **NOTICE**

This document was prepared under the sponsorship of the National Aeronautics and Space Administration. Neither the United States Government nor any person acting on behalf of the United States Government assumes any liability resulting from the use of the information contained in this document, or warrants that such use will be free from privately owned rights.

## FOREWORD

The Administrator of the National Aeronautics and Space Administration has established a technology utilization program for "the rapid dissemination of information . . . on technological developments . . . which appear to be useful for general industrial application." From a variety of sources, including NASA Research Centers and NASA contractors, space-related technology is collected and screened, and that which has potential industrial use is made generally available. Information from the nation's space program is thus made available to American industry, including the latest developments in materials, processes, products, techniques, management systems, and analytical and design procedures.

This publication is part of a series intended to provide such technical information. It was prepared from material selected and reviewed by the Battelle Memorial Institute in coordination with the following NASA Centers:

AMES RESEARCH CENTER  
Moffett Field  
Mountain View, California 94035  
FLIGHT RESEARCH CENTER  
Box 273  
Edwards, California 93523  
GODDARD SPACE FLIGHT  
CENTER  
Greenbelt, Maryland 20771  
JET PROPULSION  
LABORATORY  
California Institute of Technology  
4800 Oak Grove Drive  
Pasadena, California 91103

LANGLEY RESEARCH  
CENTER  
Langley Station  
Hampton, Virginia 23365  
LEWIS RESEARCH CENTER  
21000 Brookpark Road  
Cleveland, Ohio 44135  
MANNED SPACECRAFT  
CENTER  
Houston, Texas 7701  
GEORGE C. MARSHALL  
SPACE FLIGHT CENTER  
Huntsville, Alabama 35812

## CONTENTS

<i>Section</i>		<i>Page</i>
	INTRODUCTION.....	1
1	SHOCK ABSORBERS AND PROTECTIVE DEVICES.....	3
2	SPECIAL FABRICATION TECHNIQUES.....	11
3	<u>MACHINING</u> .....	17
4	<u>METAL FORMING</u> .....	21
	SHEET METAL.....	23
	TUBING.....	28
	BRAKES AND DIES.....	30
5	<u>WELDING AND BRAZING</u> .....	37
6	LATHE ATTACHMENTS.....	45
7	PRECISION TOOLS.....	55
8	SPECIAL TOOLS.....	65
9	SPECIAL DEVICES.....	85
10	HOISTING.....	99

v

—  
and

Start

## INTRODUCTION

During the course of nearly all mechanical prototype development projects, unusual fabrication and production requirements are encountered. To a considerable extent, projects of this type owe their success to the craft skills and inventiveness of the engineers and technicians assigned to the task; this is particularly true at the several NASA Centers.

### Useful for Industry

To a considerable extent, the final product of the NASA Centers is unusual hardware. Although many recognize only the propulsion devices or the payload elements as this hardware, there is really much more. The many other hardware items are those necessary evolutionary developments which contribute to a final new, more powerful, and more versatile system. These items may be complex systems or instruments; they may be machines or small tools; or they may be new techniques or special adaptations of existing tools or devices. Whatever the case, such items have been expedients in performing particular tasks which might otherwise have been cumbersome, very time consuming, or, in some cases, impossible. It is likely that many of these schemes, devices, or innovations might be usefully and profitably employed elsewhere in the country's industrial or private activity.

back to contents (p. v)

### Intended Especially for Machinists and Mechanics

*Selected Shop Techniques* is but one of the several means employed by the NASA Office of Technology Utilization to disseminate information to industry. *Selected Shop Techniques* is prepared especially for machinists, mechanics, and those working in related crafts. It has been prepared on the premise that "although no two problems are identical, they may certainly be similar." To this extent, *Selected Shop Techniques* does not solve problems but merely describes how problems of a particular type were solved by various members of the NASA team. It describes how fabrication obstacles were overcome by improvising, by creating new tools, or by applying an old and perhaps "all-but-forgotten" technique to a new field.

Neither NASA nor the many contributors of these ideas make any claim as to absolute originality of invention of the following ideas. It is possible that other individuals or organizations have problem and solution experience paralleling one or more of these. However, inasmuch as no other similar publication exists, *Selected Shop Techniques* is offered in the hope that shop personnel will find it useful and informative.

**SECTION 1**  
**SHOCK ABSORBERS**  
**AND**  
**PROTECTIVE DEVICES**

	<i>Page</i>
PORTABLE FLOORING TO PROTECT FINISHED SURFACES..	5
(R. J. Carmody)*	
POSITIVE STOP AND CUSHION FOR A HIGH-VELOCITY RAM..	6
(Charles Gyorgak)*	
MINIATURE VIBRATION ISOLATOR.....	7
(David H. Butler and Wilbert C. Falk)*	
BILLET RUN-OUT TABLE.....	8
(Paul Harlamert, Jr.)*	
A ONE-TIME SHOCK ABSORBER WITH LOW REBOUND MADE FROM BREAKABLE METAL TUBES.....	9
(John R. McGehee, Melvin Hathaway, and Edmond Zavada)*	

\* Innovator(s).

## PORTABLE FLOORING TO PROTECT FINISHED SURFACES

**THE PROBLEM:** To protect both irregular and flat finished surfaces from damage caused by workmen when space limitations and small access opening prohibit the use of large timbers or braces on stringers.

### SOLUTION

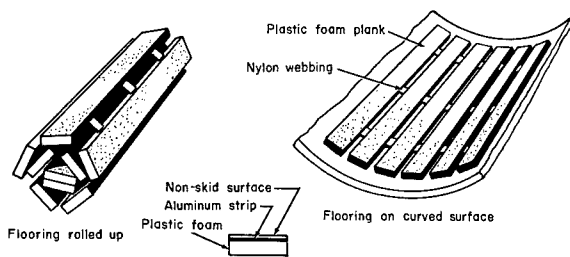

Temporary portable flooring made of rigid plastic foam will provide protection for finished surfaces. Plastic foam planks about 1 inch thick and 4 inches wide are fastened together with nylon webbing that is 2 inches wide. The length of the foam planks should be chosen to suit the application. Several methods of fastening the webbing to the planks can be used. In this application, the webbing was put through slots in the planks. Aluminum strips approximately 0.020 inch thick are glued to the

top of the planks and then an adhesive-backed nonskid surface is cemented over the aluminum. The result is a temporary portable flooring that will support the weight of workmen. It can be rolled up so that it can be carried through small openings.

Not only does the portable flooring serve as a satisfactory support for the workman and his equipment, but it will also act as a shock absorber in case something is dropped. This flooring is lighter and gives more protection than wooden mats. Also, it will distribute weight better than regular foam rubber pads. It can be constructed in the shop from ordinary materials.

*NOTE:* This portable flooring could also serve as a temporary walkway over wet surfaces.

*SOURCE:* George C. Marshall Space Flight Center (M-FS-15)

### POSITIVE STOP AND CUSHION FOR A HIGH-VELOCITY RAM

**THE PROBLEM:** To provide a positive stop and slight cushion on a high-velocity ram, thus reducing or eliminating tooling damage by preventing the tooling on the moving ram from actually contacting the stationary tooling.

#### SOLUTION

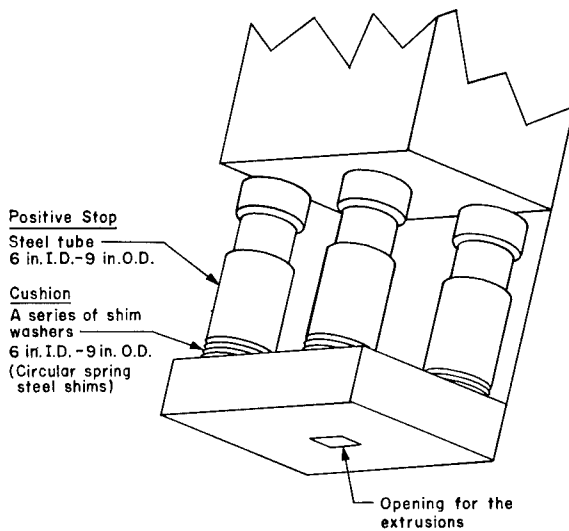

A steel sleeve tube and a set of shim washers are placed over each one of the four guide columns. Their combined height provides a clearance of  $\frac{1}{8}$  inch between the dies in the closed position. Air between the washers acts as a damper, and the excess energy is absorbed in the tubes and washers. The illustration shows how the tubes and washers are arranged. When a mechanical ram is used for extrusion, no velocity decrease occurs so that the problem of inertial separation of the material being extruded is eliminated.

*SOURCE:* Lewis Research Center (Lewis-19, Rev. A)

This is a compilation of 71 selected shop techniques for machinists, mechanics, and technicians, in which technical information generated in the nation's space program is made available to American industry, including the latest developments in <sup>material</sup> processes, products, techniques, management systems, and analytical and design procedures.

end

### MINIATURE VIBRATION ISOLATOR

**THE PROBLEM:** To protect vibration-sensitive equipment where it is not practical to use commercially available vibration dampeners because of limitations of either installation space or weight.

#### SOLUTION

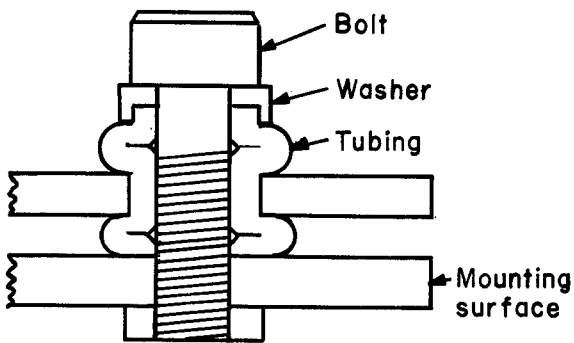

A vibration isolator has been developed that is lightweight, simple, compact, and very effective.

The isolator consists of either neoprene or silicone rubber tubing and a washer.

When the isolator is installed, the tubing is put through a properly sized hole in the unit to be isolated, with half the length of the tubing above the hole. The washer is bonded to the top of the tubing and the tubing is bonded to the unit to be isolated. A screw, chosen to fit the inside diameter of the tubing, is then passed through the washer and tubing and fastened to the mounting surface. The screw is tightened until the rubber is compressed between the unit and the mounting surface.

*SOURCE:* Langley Research Center (Langley 2-A)

### BILLET RUN-OUT TABLE

**THE PROBLEM:** To catch extrusions from high-energy rate extrusion presses.

#### SOLUTION

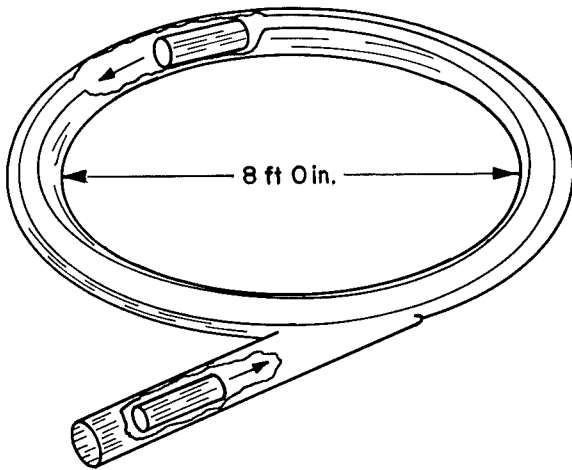

A length of pipe can be welded and bent to form a billet run-out table which will retrieve high-velocity extrusions. A pipe of appropriate diameter can be bent into a circle approximately 8 feet in diameter, forming a torus. A length of straight pipe leading out of the press is joined to the torus on a tangent. As an extrusion is ejected from the press at high speed, it travels down the straight pipe and around the torus, expending its energy in a safe manner. The top portion of the torus is cut away to permit removal of the coiled extrusion.

*SOURCE:* Lewis Research Center (Lewis—141)

## A ONE-TIME SHOCK ABSORBER WITH LOW REBOUND MADE FROM BREAKABLE METAL TUBES

**THE PROBLEM:** To dissipate large amounts of energy when low rebound following shock absorption is required.

### SOLUTION

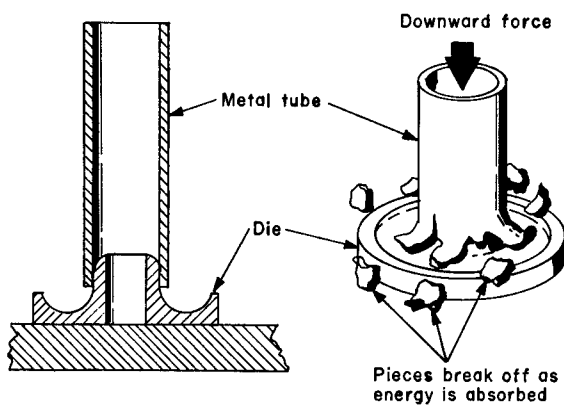

A breakable metal tube shock absorber has been developed. A metal tube is so placed that the downward motion forces the tube against a suitably shaped die, such as a torus. As the tube presses against the die, it shatters by successive fragmentation. Energy absorption results when a force is required to fragment the tube through a large portion of its length.

Any number of frangible tube and die combinations could be used, depending upon design requirements. Tube length and diameter can be varied, within limits, to suit the application.

The tube must be oriented so that the force is applied along the tube longitudinal axis, and not tangentially. Some mechanisms, such as a

linkage, could be used to insure axial loading of the tubes.

The energy-absorption capability of this device is much greater than most existing energy absorption processes. Another valuable characteristic is the almost total lack of rebound. Putting a taper on the end of the tube that contacts the die enables the designer to avoid the high initial forces otherwise required to start the fragmentation. Also, this taper permits some control of the rate of force application.

### NOTES:

1. Other applications of this one-time shock absorber might include elevator decelerators, instrument mountings, mountings for passenger seats, and impact testing. Other potential industrial uses are in automobile and aircraft seat belts, guard rails on highways, and shock protection equipment for transportation of expensive or delicate machinery.
2. NASA TN D-1477, entitled "A Preliminary Experimental Investigation of an Energy-Absorption Process Employing Frangible Metal Tubing," by John R. McGehee, October 1962, provides information on this innovation.

**SOURCE:** Langley Research Center (Langley 1-A)

**SECTION 2**  
**SPECIAL FABRICATION TECHNIQUES**

	<i>Page</i>
O-RING RETAINER..... (Robert L. Walker, Jr. and Harry Nickolson)*	13
CONSTRUCTION OF WIND TUNNEL MODELS.....	14
TEMPORARY HONEYCOMB ALUMINUM/PLASTIC TOOLING BLOCKS..... (R. J. Carmody)*	15

\*Innovator(s).

### O-RING RETAINER

**THE PROBLEM:** To hold O-rings of large diameter in place while adjacent parts are being assembled.

#### SOLUTION

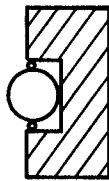
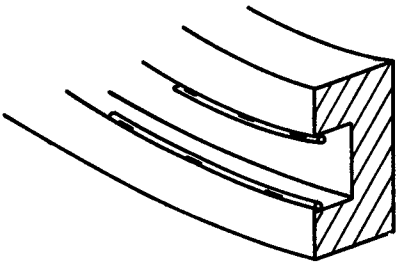

An easy economical method has been developed for installing O-ring retainers. Short lengths of stainless wire are spot welded in pairs around the O-ring groove at intervals of 15 inches. The wires are welded opposite each other, but they are of different lengths to avoid a pinching hazard. This method eliminates the need for specially designed grooves.

*SOURCE:* Lewis Research Center (Lewis-36)

## CONSTRUCTION OF WIND TUNNEL MODELS

**THE PROBLEM:** To construct accurate scale models or patterns easily and quickly.

### SOLUTION

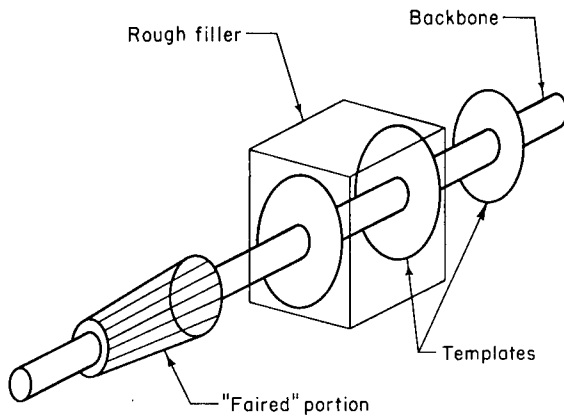

graphs of these cross sections from which the metal templates are developed. The thickness of the metal stock will be dictated by the size of the model. Arrange the templates on a rigid backbone, such as a tube, and place them at their proper scale spacing. Use mahogany or balsa wood blocks as fillers between the templates (plaster may also be used). Place blocks so that the grain runs with the axis of the model. Work or "fair" the filler material down to the templates until the model or pattern is finished.

*SOURCE:* Langley Research Center (Langley-23)

Using the design drawings, draw cross sections of desired sections. Prepare scaled photo-

## TEMPORARY HONEYCOMB ALUMINUM/PLASTIC TOOLING BLOCKS

**THE PROBLEM:** To provide temporary support blocks for jobs that do not warrant the machining of permanent support blocks from solid aluminum.

### SOLUTION

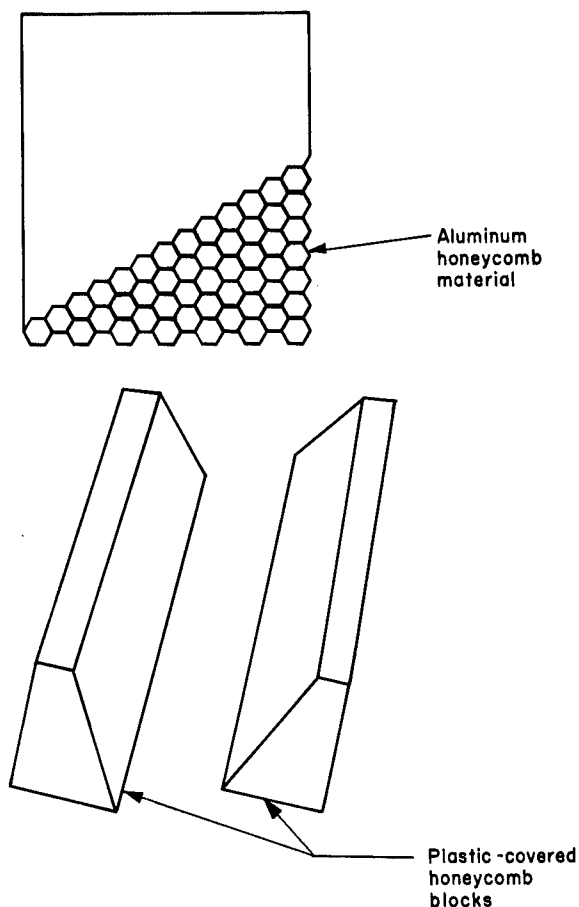

Temporary support blocks or "tooling" can be fabricated from honeycomb aluminum blocks and plastic. The blocks are cut with a bandsaw and coated with a high-temperature plastic. The plastic coating is  $\frac{1}{4}$ -inch thick and covers all sides of the honeycomb block. After a 10- to 12-hour hardening period, the honeycomb aluminum/plastic blocks are ready for use as support blocks.

### NOTES:

1. These blocks may be sanded smooth if desired, and they are serviceable at temperatures up to 350° F.
2. Although not as long lasting as solid aluminum blocks, these honeycomb aluminum/plastic blocks are more economical, faster to make, and over 50 percent lighter.
3. Solid plastic tooling can be used, but molds must be fabricated, and aluminum granules or "seed" should be interspaced within the plastic.

**SOURCE:** George C. Marshall Space Flight Center (M-FS-149)

**SECTION 3**  
**MACHINING**

	<i>Page</i>
A METHOD FOR MACHINING SPHERICAL SHAPES..... (Dale Shute)*	19
HARD-ANODIZED ALUMINUM LAPS..... (William J. Abernathy)*	20

\_\_\_\_\_  
\*Innovator.

## A METHOD FOR MACHINING SPHERICAL SHAPES

**THE PROBLEM:** To machine spherical shapes using equipment readily available in an average machine shop. Any method devised must provide an adjustment for varying the radius, and it should incorporate the option of machining both concave and convex spherical shapes.

### SOLUTION

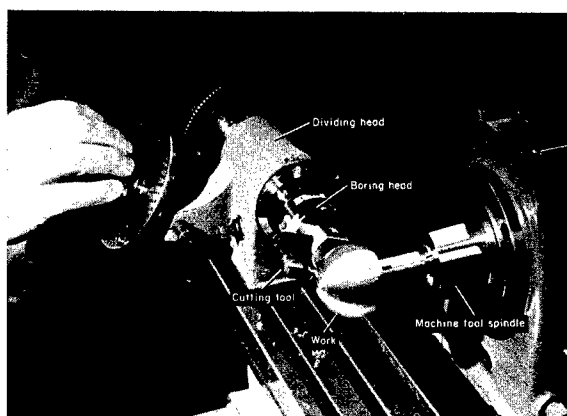

Spherical shapes can be generated on a horizontal milling machine. A dividing head with a boring head attached is mounted on a work table. A single-point cutting tool is supported by the boring head, and the work is held in the spindle of the machine. The photograph illustrates the relationship of the tools to the work

and shows a convex spherical shape being machined. Concave spherical shapes may also be machined by this method. As the work is rotated in the spindle of the mill, a spherical shape is generated when the single-point cutting tool is positioned on the work.

In the photograph, the axis of the sphere being turned is coincident with the centerline of the milling machine spindle. It is also possible, by this method, to generate radii whose axes do not coincide with that of the milling machine spindle. The method provides for graduated adjustment for every plane as well as for the radius.

### NOTES:

1. This method would be useful in machine shops where the purchase of special tools to machine radii is not feasible.
2. This method could be used to fabricate noses for wind-tunnel models.

*SOURCE:* Ames Research Center (ARC-33)

## HARD-ANODIZED ALUMINUM LAPS

**THE PROBLEM:** To achieve longer life for laps used to prepare highly polished surfaces.

### SOLUTION

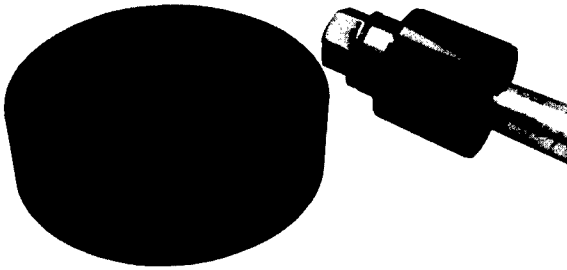

Hard-anodized aluminum laps will last longer before reworking is necessary and will produce better quality work than the laps commonly used. To make these laps, an aluminum alloy plate, 6061, is ground flat, stress relieved, and then lapped flat. No serrations are used

in the flat laps. The lap is hard-anodized to a thickness of 0.002 to 0.004 inch and the anodized plate is relapped to remove any plated roughness or porosity.

These laps will generally stay flat much longer than laps made of other materials. They may be reconditioned by first stripping the worn anodized surface and then reanodizing. No machining is necessary.

Round laps have serrations which are broken with generous radii. The radii are necessary because anodized coatings are not continuous over sharp corners.

*SOURCE:* Marshall Space Flight Center (M-FS-95)

## SECTION 4

### METAL FORMING

	<i>Page</i>
<b>SHEET METAL</b>	
A ONE-PIECE, ONE-SEAM, ELLIPSOIDIAL TANK..... (Joseph Bizyak)*	23
FORMING A SHEET-METAL HELIX.....	24
FORMING TANK ENDS WITHOUT PRESSES..... (Joseph Bizyak)*	25
FORMING DISHED HEADS..... (John H. Chattin)*	26
FIXTURE FOR CUSTOM FABRICATION OF METAL BEL- LWS..... (Carl G. Richter, Julius E. Trombetto, and Clarence Mamere)*	27
<b>TUBING</b>	
CORRECTING DISTORTION AFTER BENDING TUBING..	28
SPECIAL TUBE BENDER FOR STAINLESS STEEL TUBING.. (E. L. Stone)*	29
<b>BRAKES AND DIES</b>	
EMBOSSING DIE..... (Kenneth B. Wilton)*	30
SHEET TUNGSTEN LOWER FORMING DIE.....	31
ADJUSTABLE DIE WAYS..... (Howard J. Pierce)*	32
FORMING WIRE GRIDS..... (John L. Bonn and Daniel E. Gardner)*	33
FABRICATION OF TUNGSTEN RIVETS.....	34
SHEET METAL BENDING BRAKE..... (Kenneth B. Wilton and Alfred L. Ercoline)*	35

---

\*Innovator(s).

### A ONE-PIECE, ONE-SEAM, ELLIPSOIDIAL TANK

**THE PROBLEM:** To form an ellipsoidal tank when the exact shape is not critical.

#### SOLUTION

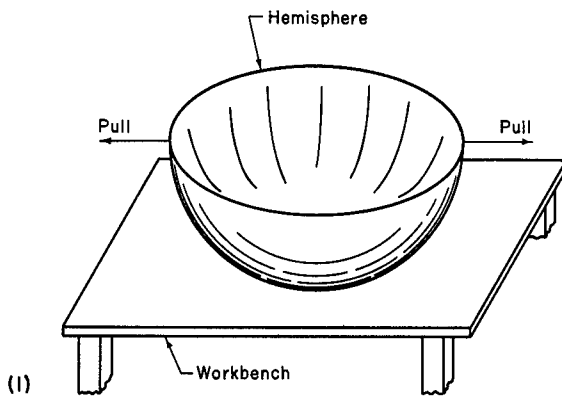

(1)

A one-piece, one-seam ellipsoid may be made by deforming a metal hemisphere. The hemisphere is placed on a workbench as shown in figure 1. A pull is applied to two opposite points to deform the hemisphere. As the pull is completed, the metal will close up, and one

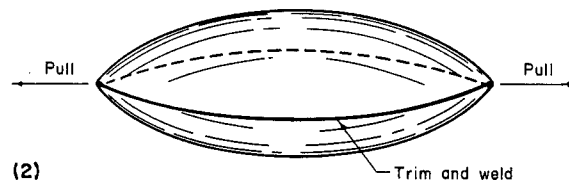

(2)

edge can be folded inside the other as shown in figure 2. When the desired size and shape have been obtained, the metal can be trimmed and welded along the single seam.

#### NOTES:

1. This method may be clearly demonstrated with half of a hollow rubber ball.
2. This method is valuable only when the exact shape and size of the tank are not critical.

*SOURCE:* Lewis Research Center (Lewis—200)

### FORMING A SHEET-METAL HELIX

**THE PROBLEM:** To form a sheet-metal helix of specified pitch, four blades were required.

#### SOLUTION

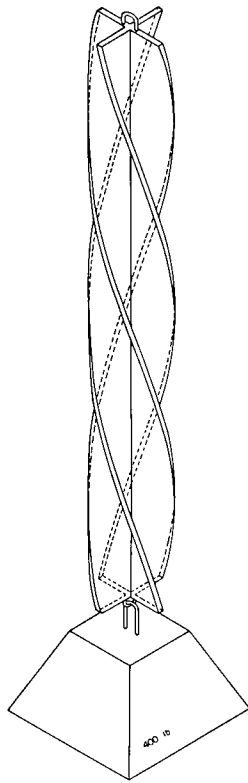

Fabricated sheet metal can be twisted, under tension, to form the required helix. The sheet metal is first welded into the desired cross-sectional form, which in this case is an X-section. The sketch shows loops (formed by doubling back one of the sheet metal strips prior to welding) at each end of the workpiece. The workpiece is then suspended from a rigid mount, such as a crane. A small beam (in this case, a press brake die), 5 to 6 feet long and suspended at its center, acts as a weight at the lower end of the workpiece. This beam has the dual purpose of providing tension and controlling pitch. Two men, one at each end of the beam, walk around in a circle the required number of times to form the helix.

*SOURCE:* Lewis Research Center

## FORMING TANK ENDS WITHOUT PRESSES

**THE PROBLEM:** To produce dome-shaped tanks without the use of expensive hydraulic press dies. (This method was developed to make tanks from  $\frac{1}{8}$  to  $\frac{1}{4}$  inch thick, and from 4 to 6 feet in diameter.)

### SOLUTION

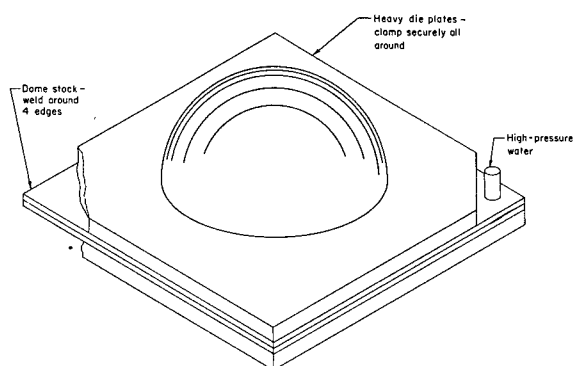

Dome-shaped tanks can be formed by using water pressure. Two square sheets of plate stock are placed one on top of the other, and an inlet pipe is inserted between them. The whole assembly is then welded along all four edges. Two heavy plate dies with circular holes cut out of their centers are clamped onto the welded

piece. As hydraulic pressure is applied through the inlet pipe, the welded assembly expands through the circular holes in the dies, forming a hemispherical tank. The die is removed, and the tank is trimmed for use as tank ends.

### NOTES:

1. This technique may be varied by welding in two water pipes that are diametrically opposed. With the welded assembly in a vertical position, the bottom pipe serves as a hydraulic pressure inlet, while the other is kept open long enough to allow the air in the assembly to escape.
2. A rubber gasket, under certain conditions, can be substituted for the weld. If a heavy solid backup plate is used as one die, a single hemisphere can be drawn instead of drawing two opposed to each other.

*SOURCE:* Lewis Research Center (Lewis-162)

### FORMING DISHED HEADS

**THE PROBLEM:** To produce an economical and more uniform dished head without using forming dies and spinning forms.

#### SOLUTION

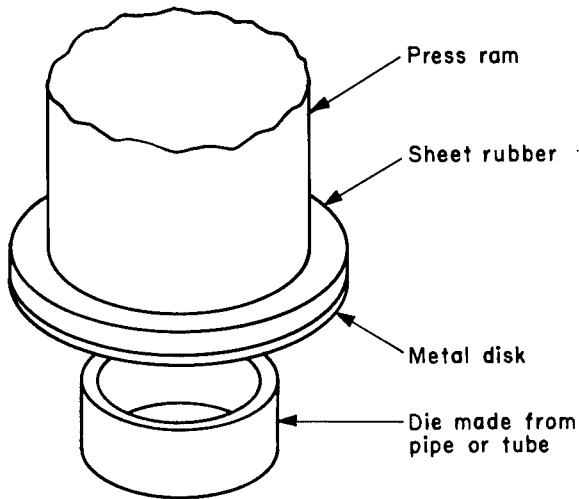

Uniform dished heads can be produced by using a piece of pipe, a thick rubber pad, and a press ram. The piece of pipe will serve as a die. A metal disk is placed over the pipe. This disk must have the same outside diameter as that of the pipe. A thick rubber pad is laid over the metal disk, a press ram that has a larger diameter than the rubber pad is brought into place, and pressure is applied. The press ram forces the rubber pad to displace the metal disk into the die, forming a uniform dished head.

*NOTE:* Since the rubber pad displaces the metal disk, the depth of the "dish" will be directly proportional to the thickness of the rubber pad.

*SOURCE:* Lewis Research Center (Lewis-62)

## FIXTURE FOR CUSTOM FABRICATION OF METAL BELLOWS

**THE PROBLEM:** To fabricate a wide variety of sheet metal bellows required on short notice.

### SOLUTION

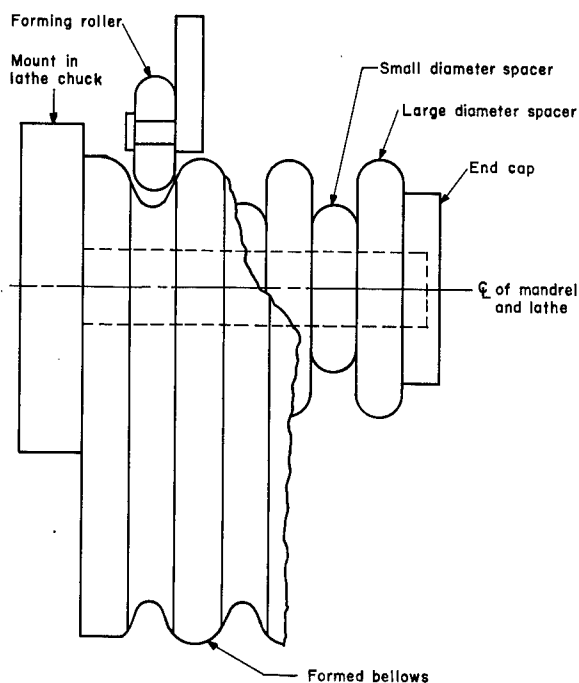

Sheet metal bellows may be quickly fabricated from straight thin sheet metal tubing by using a forming wheel which rolls the desired grooves successively into the tubing. As shown in the sketch, a shouldered mandrel is made with the larger end to be held in the lathe chuck. The working end is a smaller diameter, i.e., substantially smaller than the desired inside diameter of the bellows to be formed (see sketch). Alternating small and large spacer rings are slipped onto the working end of the mandrel with a sliding fit. These spacers are

made to the desired size such that the difference between the outside radii of the small and large spacers is equal to the depth of the desired bellows corrugations. Also, the width of both the large and small spacers is equal to the desired width of the bellows corrugations. The assembly on the mandrel is completed by attaching an end cap to hold the spacers in place, the mandrel assembly chucked in the lathe, and the endcap centered against the tailstock.

The straight section of sheet metal tubing to be formed is slipped over the mandrel assembly. The bellows corrugations are formed, one at a time, by applying pressure with the forming wheel against the side of the tubing midway between each pair of large spacers. Thus, each corrugation is formed by forcing a section of the tubing into the groove formed by a small spacer between two large spacers. After forming, the bellows is readily slipped from the mandrel assembly, since the inside diameter of the bellows is substantially larger than the outside diameter of the large spacers (refer to the sketch).

**NOTE:** This technique provides a simple means of custom fabricating sheet metal bellows from any readily formable metal tubing. By using spacers of various outside diameters and widths and, where necessary, mandrels of various diameters and lengths, an infinite variety of bellows sizes can be fabricated quickly by simple machine shop operations.

**SOURCE:** Lewis Research Center (Lewis-192)

### CORRECTING DISTORTION AFTER BENDING TUBING

**THE PROBLEM:** To correct the collapse or distortion in tubing that results when bending tubing.

#### SOLUTION

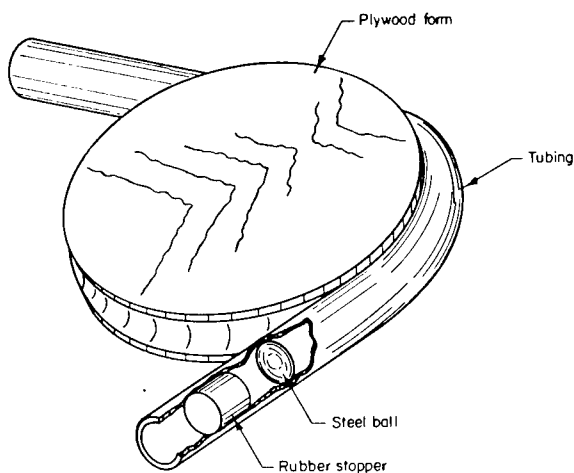

Forcing a steel ball through the tubing will expand the collapsed outer wall. Shape the tube around a form as is normally done. (Provide forms on both sides of each tube bend.) While the tube is still in place, insert a steel ball having a diameter nearly that of the outside diameter of the tube. Follow the steel ball with a rubber piston. Force the piston and ball through the tube hydrostatically to expand the collapsed portion of the tubing. The sketch shows a typical arrangement.

*SOURCE:* Lewis Research Center

### SPECIAL TUBE BENDER FOR STAINLESS STEEL TUBING

**THE PROBLEM:** To bend stainless steel tubing without collapse of the tube at the bend. (Teflon filler rods can be used to prevent this collapse, but their use is time consuming.)

#### SOLUTION

A specially designed tube bender that can be made in the shop makes satisfactory bends in stainless steel tubing. The tool is similar in appearance to standard tube benders. The major difference in its design, however, is the presence of a groove in the wiper arm and a deeper groove in the disk. As shown in the sketch, the centerline of the stainless steel tubing to be bent lies below the outer edge of the disk. When the wiper arm is closed over the tubing and pressure is applied, the deepened grooves of the disk prevent the tubing from expanding sidewise and, thus, collapsing radially with respect to the bend being formed.

*SOURCE:* Marshall Space Flight Center  
(M-FS-53)

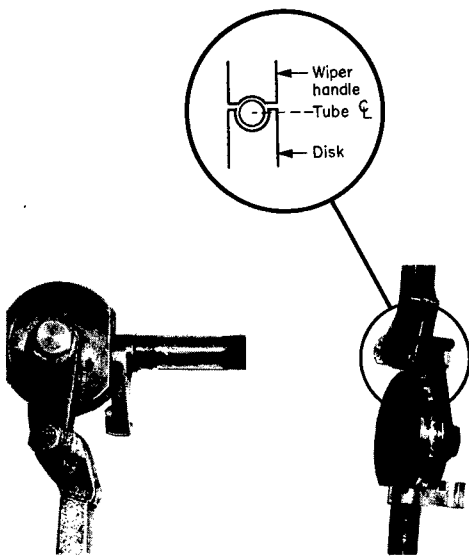

## EMBOSSING DIE

**THE PROBLEM:** To emboss light gage sheet metal economically for stiffness or for decoration.

### SOLUTION

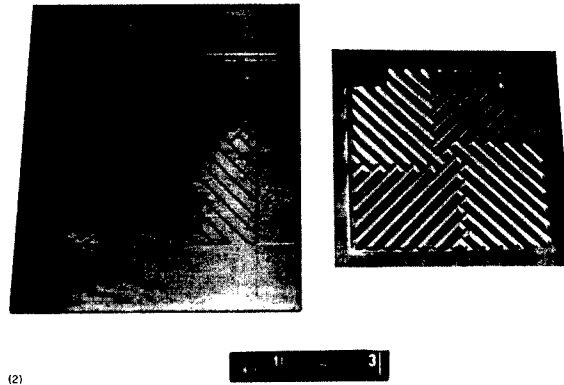
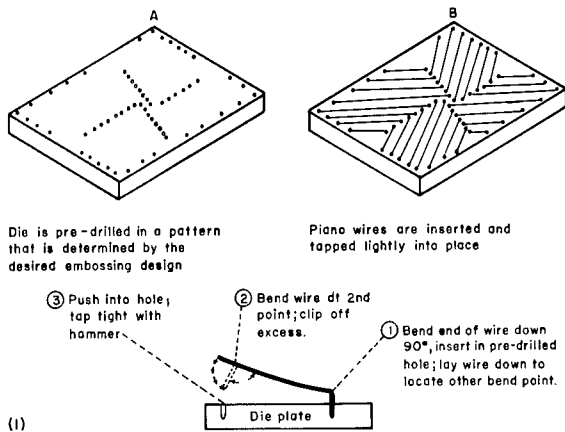

An embossing die can be fabricated by any competent machinist who has access to a drill press, some piano wire, and a piece of mild steel. Figure 1 illustrates the die and shows the two-step procedure for its fabrication.

In operation, the die is placed face up on the bed of a hydraulic press. The material to be embossed is placed on the die and a block of elastic material, such as rubber, stafoam, plastic, and the like, is placed on top of the material. Hydraulic pressure is then applied, causing the die wires to emboss the material.

Figure 2 shows the actual embossing die and a piece of embossed aluminum.

#### NOTES:

1. One obvious advantage to this innovation is the ease of its construction. There is no need for a tool and die maker.
2. Virtually any embossing pattern can be formed, as die modifications are easily made.
3. Care must be exercised to avoid locking the workpiece around the wire by the application of too much hydraulic pressure.

*SOURCE:* Ames Research Center (ARC-30)

### SHEET TUNGSTEN LOWER FORMING DIE

**THE PROBLEM:** To provide a means for efficient heating of tungsten for forming without resulting high breakage.

#### SOLUTION

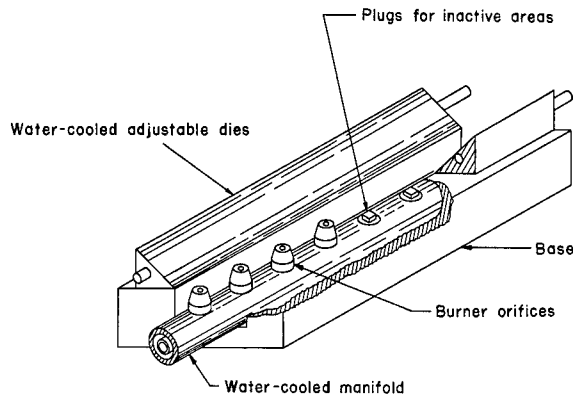

A special lower forming die will heat tungsten without breakage. The sketch shows the gen-

eral layout of the die. The dies, adjustable at the base, are made of stainless steel and are water cooled. A hydrogen-oxygen heating manifold is placed between them. The manifold is also water cooled. Burner orifices are placed at  $\frac{1}{2}$ -inch intervals along the manifold. They are removable and plugs can be inserted in their place.

#### NOTES:

1. This die has worked so well that practically no breakage occurs, and production is greatly increased.
2. This die will be useful in any metal forming operation where the workpiece must be heated.

*SOURCE:* Lewis Research Center (Lewis-25)

### ADJUSTABLE DIE WAYS

**THE PROBLEM:** To overcome the nonuniform bends that are inherent in press brake work.

#### SOLUTION

A press brake forming die with adjustable die ways enables uniform bends without requiring hammer or press rework of formed pieces. As shown in the sketch, the channel-shaped base of the adjustable die contains a number of adjustable screws located at uniform intervals. The die ways are placed inside the channels and are held to the channel by set screws. Control of a bend is then obtained by adjusting the separation of the ways, along their length, with the adjustable screws.

*SOURCE:* Marshall Space Flight Center  
(M-FS-146)

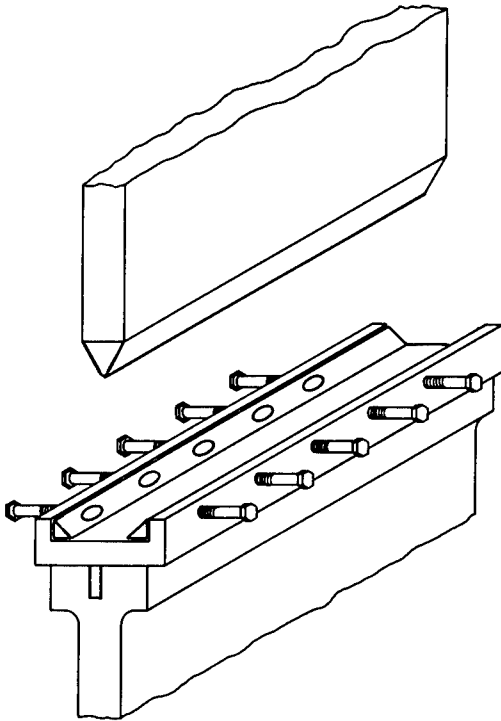

### FORMING WIRE GRIDS

**THE PROBLEM:** To form static strain gages that are permanently set and easy to handle.

#### SOLUTION

A fixture can easily be built to form the gage and to provide a means of setting the wire once it has been formed. A matching block is made at the same time that the fixture is being constructed. After the gage has been formed around the protruding pins of the forming jig, it is squeezed slightly between the fixture and the matching block. This method gives the wire a permanent set and makes the gage easier to handle.

*SOURCE:* Lewis Research Center (Lewis-182, 183)

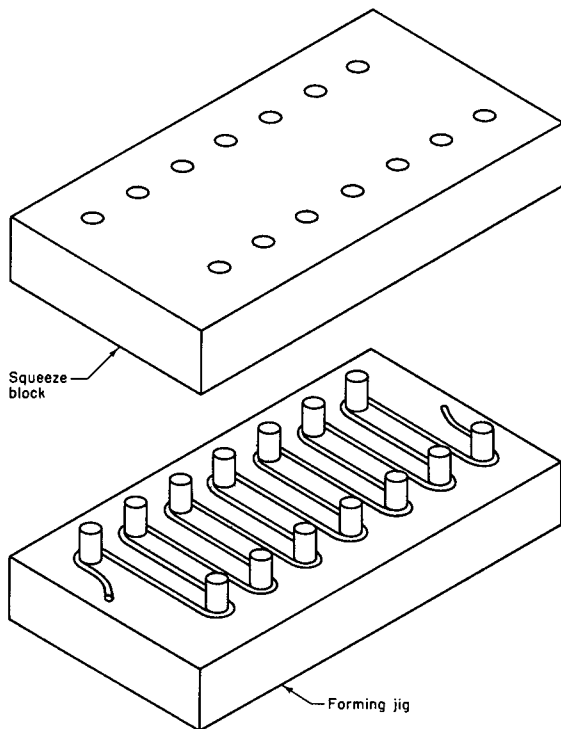

### FABRICATION OF TUNGSTEN RIVETS

**THE PROBLEM:** To fabricate easily and economically tungsten rivets that are not otherwise readily available.

#### SOLUTION

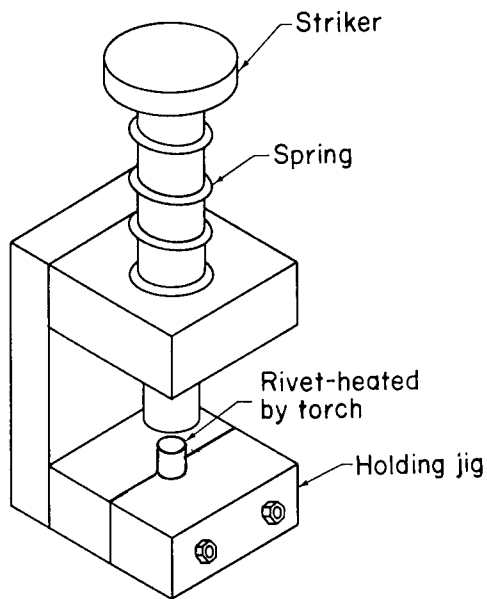

A device can be built that will permit rivet stock to be forged after heating it to the proper temperature.

As shown in the sketch, the tungsten rivet stock is positioned on the die portion of the device, with a sufficient amount of stock provided to allow for the forming of the rivet head. The stock is heated with a hand torch. The spring holds the striker far enough away from the heat to prevent annealing. When the stock has reached the proper temperature, the striker is depressed with a sharp blow from a hammer to form the rivet head. The spring retrieves the striker.

*NOTE:* Previous practice called for grinding rivets to size from small tungsten bar stock at a cost of \$9.00 each (as compared with \$0.15 each by this method).

*SOURCE:* Lewis Research Center

## SHEET METAL BENDING BRAKE

**THE PROBLEM:** To make small (micro) reverse bends in light gage sheet metal.

### SOLUTION

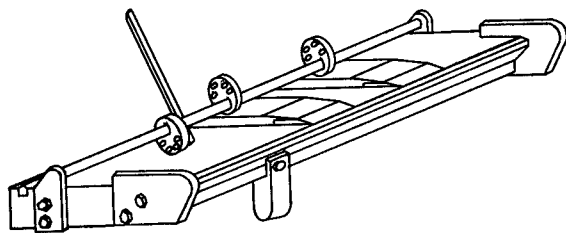

(1)

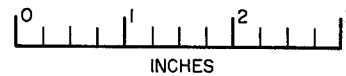
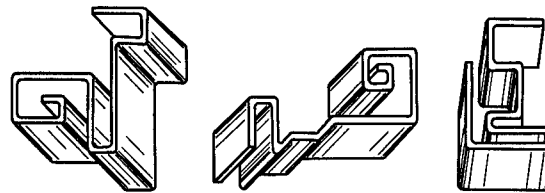

(3)

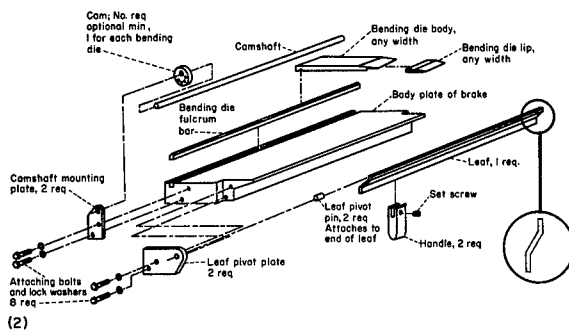

(2)

A metal bending brake can be assembled economically from readily available materials. Figure 1 shows the brake set up and ready to use. Hand operation of the cams will usually lock the die lips in place. If greater pressure

is required, the handle can be used. Figure 2 is an exploded view showing the construction of the brake. Sizes can be determined from the requirements of the work and the material available. Figure 3 shows some representative bends made on the brake.

#### NOTES:

1. Die lips can be custom made.
2. Care must be exercised to avoid overloading the brake.
3. Complex reverse bends are possible.
4. This brake is essentially an improvement over other brakes currently in use.

*SOURCE:* Ames Research Center (ARC-29)

**SECTION 5**

**WELDING AND BRAZING**

	<i>Page</i>
A METHOD FOR WELDING A CLOSED VESSEL.....	39
(Clarence Levoe and Robert Freeman) *	
INERT-GAS WELDING NOZZLE FOR USE IN DRAFTY AREAS..	40
(Willis G. Growth) *	
MINIATURE CUTTING TORCH.....	41
(Paul Shlichta) *	
INCREASING WELD JOINT STRENGTH.....	42
(D. Vesco) *	
TEST PLUG.....	43
(Albert G. Willis) *	
HELIARC WELDING CHAMBER.....	44
(John C. Laughlin) *	

\*Innovator(s).

### A METHOD FOR WELDING A CLOSED VESSEL

**THE PROBLEM:** To weld closed vessels of various shapes that must be assembled by welding but are designed with only a few small access holes. They can be welded only from the outside so that it is difficult to avoid burning holes in the vessel or weakening the surface.

#### SOLUTION

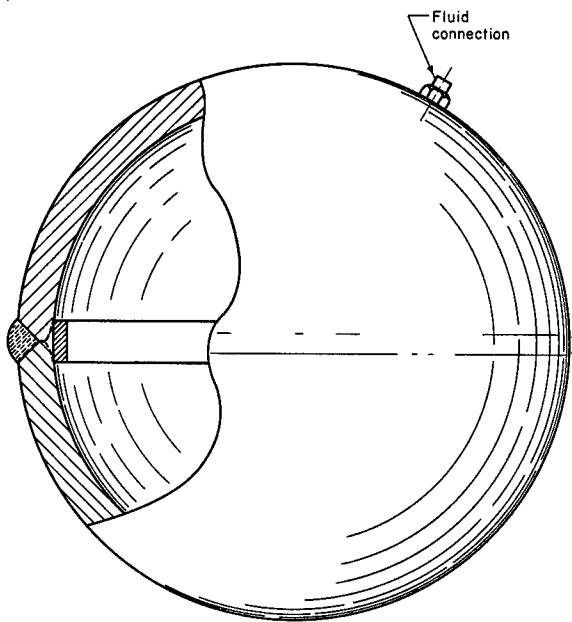

A backup strip of suitable material will facilitate closed vessel welding. A backup strip should be selected that has good conductivity and can be dissolved by a liquid reagent. A reagent should be chosen that will attack the backup strip, but not the vessel. For this example, the vessel is made of 2014-T6 aluminum, the backup strip is copper, and the reagent is nitric acid.

The two sections to be welded are shown in position for welding. The metal backup strip is first fitted into one of the sections in the form of a band on the inside periphery of the vessel. About half the width of the backup strip is placed to fit snugly into the selected section of the vessel. (The backup strip also helps orient the two sections of the vessel.) The exterior is then conventionally welded.

After the vessel cools, a chemically reactive reagent, here nitric acid, is poured through a small opening in the vessel, allowing it to dissolve the backup strip. After the strip has been completely dissolved, the reagent is drained from the vessel.

#### NOTES:

1. If the vessel is made of stainless steel, a backup strip of aluminum may be used. A caustic soda solution will dissolve the aluminum, but it will not attack the stainless steel vessel.
2. The backup strip may be split to permit insertion into the vessel during assembly.
3. A vent may be made in the vessel, prior to welding, to provide a passage for the reagent.

*SOURCE:* Jet Propulsion Laboratories (JPL-170)

### INERT-GAS WELDING NOZZLE FOR USE IN DRAFTY AREAS

**THE PROBLEM:** To insure that when large items are being welded in a shop area, air currents do not disrupt the gas-shielding that is provided by the welding nozzle and distribute objectionable welding fumes.

#### SOLUTION

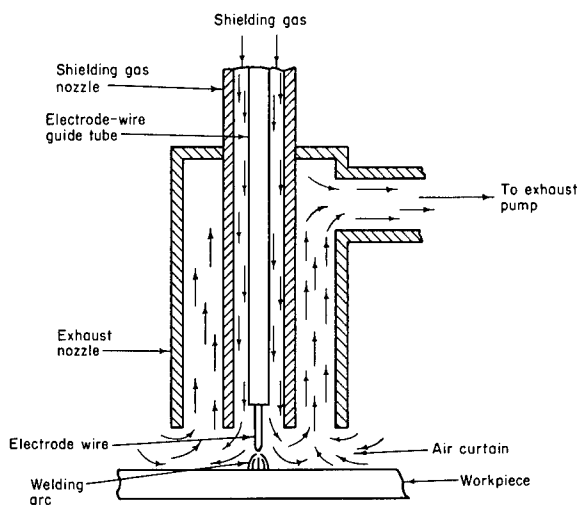

A special inert-gas welding nozzle has been developed to protect the shielding gas envelope from air currents and remove the welding fumes from the area. The schematic shows the principles of the nozzle. The conditions of each job must be determined and gas flow studies made to establish the nozzle dimensions. *SOURCE:* George C. Marshall Space Flight Center (M-FS-45)

### MINIATURE CUTTING TORCH

**THE PROBLEM:** To develop a miniature cutting torch that produces a smaller cutting flame than that provided by conventional torches.

#### SOLUTION

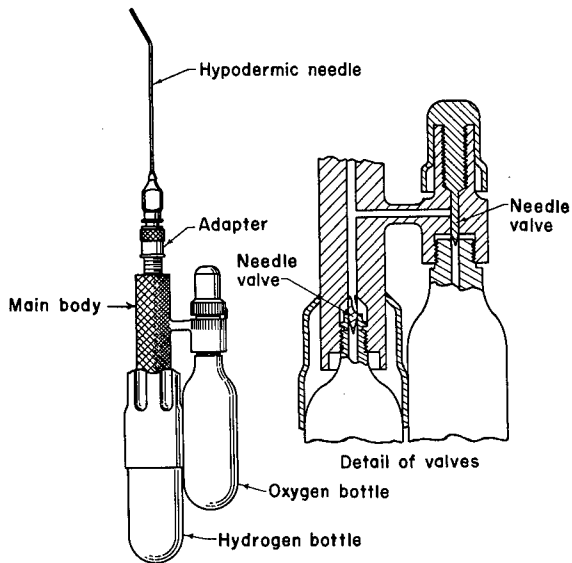

Fabricate such a torch from available materials. The three standard items required to make a miniature torch are (1) a hydrogen bottle, (2) an oxygen bottle, and (3) a hypodermic needle. The sketch shows the relationship of the various components and the form of the main body and interconnecting tube. The body can be cut from solid metal or built up from tubing, whichever is most convenient. Oxygen control is achieved by turning the needle valve against the bottle opening. Hydrogen control is achieved by turning the hydrogen bottle against a fixed needle valve in the body.

*SOURCE:* Jet Propulsion Laboratory (JPL-545)

## INCREASING WELD JOINT STRENGTH

**THE PROBLEM:** To overcome the reduced strength of the parent metal immediately adjacent to a weld caused by the adverse effects of welding heat.

### SOLUTION

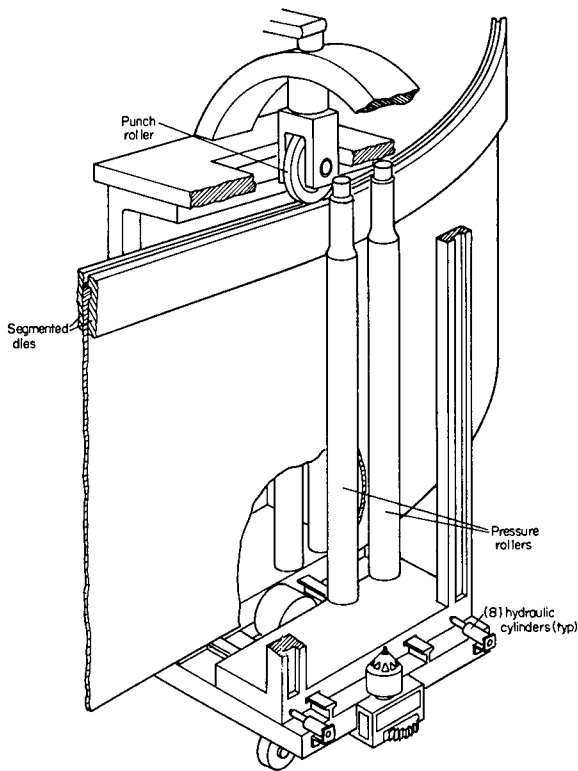

Increasing the material thickness in the area of the weld by upsetting will compensate for the reduced strength of the parent metal. The sketch shows a setup used to prepare circular skin sections, but variations can be contrived for other sheet metal parts. Basically, the edge to be welded is clamped between retaining dies that have a cavity conforming to the desired upset pattern. Hydraulic pressure applied through rollers forces the metal into the die cavity.

*NOTE:* This principle can be used for the squaring of sheets or for the sizing of cylinders. In addition, the upset pattern of the metal edge can be of any configuration, e.g., flat, angular, or radial.

*SOURCE:* George C. Marshall Space Flight Center (M-FS-175)

## TEST PLUG

**THE PROBLEM:** When cut-ins are made in a process system, to test welds or screw connections hydrostatically without contaminating or filling the entire system with test fluid.

## SOLUTION

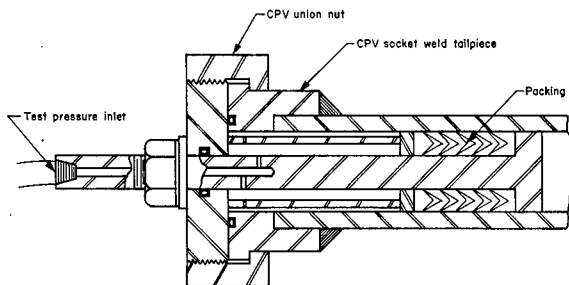

A test plug has been designed and used to test a high-pressure helium system. The particular plug used at this center was designed for use

with 1¼-inch XXH pipe with a socket weld union connection; a specimen was tested successfully at 10,000 psi.

### NOTES:

1. Each test plug must be designed for a specific application depending upon pipe size, type of end connection, and test pressure.
2. The plug will test structurally for radial stresses and for tightness of the system.

*SOURCE:* Langley Research Center (Langley-17)

## HELIARC WELDING CHAMBER

**THE PROBLEM:** To provide an inert atmosphere and to control the pressure of the atmosphere in a welding chamber.

### SOLUTION

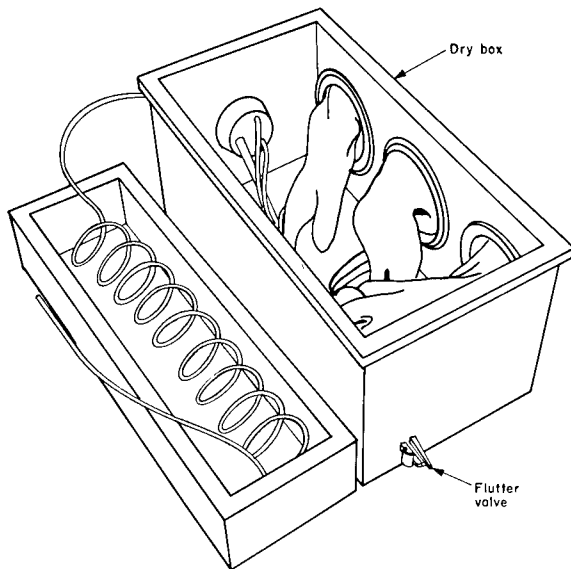

A welding chamber, using continuously flowing inert gas which is kept at a constant pressure, has been developed. Essentially, it is a standard dry box equipped with either a flutter valve or a water manometer to provide a means for excess gas to escape. The chamber incorporates long rubber gloves which project inward from one side and are used by the welder to manipulate the work.

#### NOTES:

1. Gloves are provided for a welder's assistant.
2. The transparent cover is constructed of pyrex for protection from the heat generated in the welding process.

*SOURCE:* Lewis Research Center (Lewis-143)

## SECTION 6

### LATHE ATTACHMENTS

	<i>Page</i>
CONSTANT TENSIONING FIXTURE..... (Casey J. Blaze and Carl G. Richter)*	47
HEATED TUNGSTEN MACHINING..... (W. A. Forshey and H. H. Copuss)*	48
MAKING A SPIRAL MAGNETIC COIL FROM NARROW SHIM STOCK..... (Casey J. Blaze)*	49
CONTROLLED PRESSURE CLAMPING DEVICE..... (J. M. Auerbach and Casey J. Blaze)*	50
LAPPING SPOTFACES..... (W. J. Abernathy, W. J. Reed, J. R. Sealy, and L. G. Snoddy)*	51
IMPROVISED EXPANDING MANDRELS..... (Leonard A. Wilhelmi)*	52
UNIVERSAL LATHE AND JIG BORE FIXTURE HOLDER FOR PRECISION MACHINE WORK..... (John R. Sealy)*	53

\*Innovator(s).

### CONSTANT TENSIONING FIXTURE

**THE PROBLEM:** To maintain constant tension in winding coils on a lathe with a device that is not as cumbersome and as vulnerable to abrupt bends in the wire as is the standard wood block assembly.

#### SOLUTION

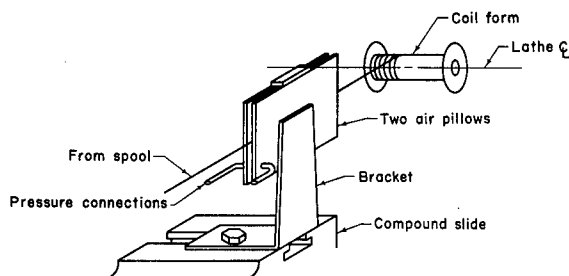

One of the applications of expandable air pillows can be applied to maintain tension when winding coils on a lathe. The wire is drawn between two skid blocks which are forced together by expandable air pillows on the outer side of each skid block. The tubing to each air pillow is joined together at a wye to provide equal and constant air pressure on each side.

*SOURCE:* Lewis Research Center (Lewis 175)

## HEATED TUNGSTEN MACHINING

**THE PROBLEM:** To provide a controlled application of heat both prior to and during the machining operation of refractory metals, such as tungsten. This heat significantly improves the machinability of refractory metals.

### SOLUTION

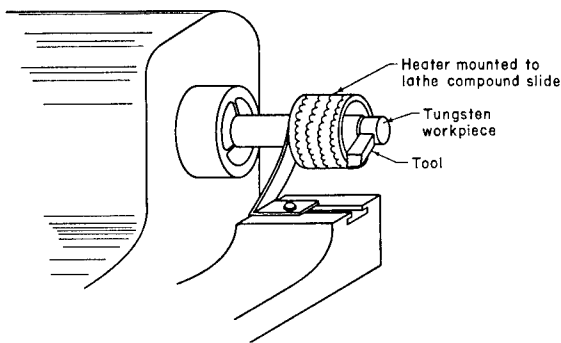

An electric heating wire coiled around a stationary tube, inside of which the workpiece can revolve freely, will supply the required heat needed for lathe work. A heater is made by

coiling nichrome wire around a tube whose inside diameter is larger than the outside diameter of the workpiece. The heater is mounted to the lathe cross slide in such a way that it travels just clear of the cutting tool. In this manner, the work is kept at the proper machining temperature.

*NOTE:* Limited additional investigations have been conducted covering concurrent controlled heating of the cutting tool versus intermittent tool cooling. There have been no significant results showing the superiority of one method over the other.

*SOURCE:* Lewis Research Center (Lewis—31)

### MAKING A SPIRAL MAGNETIC COIL FROM NARROW SHIM STOCK

**THE PROBLEM:** To fabricate a coil from narrow shim stock so that the thin side of the stock is wrapped perpendicular to the axis of the coil.

#### SOLUTION

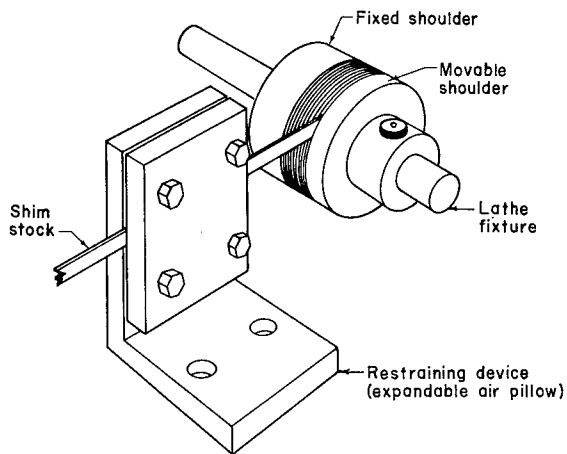

A special lathe fixture and a restraining device will facilitate the winding of shim stock on its side edge. The sketch shows the fixture and restraining device. Sizes can be determined from the nature of the coil and from the lathe to be used. Fasten an end of the shim stock to the fixed shoulder with a machine screw. The movable shoulder is repositioned at the completion of each revolution. It is moved outward just enough to permit winding another turn of the stock.

**NOTE:** The restraining device holds the stock at constant tension by use of expandable air pillows.

**SOURCE:** Lewis Research Center (Lewis-198)

### CONTROLLED PRESSURE CLAMPING DEVICE

**THE PROBLEM:** To clamp workpieces with a constant pressure where conventional pneumatic devices are unavailable or rubber components limit the working temperature.

#### SOLUTION

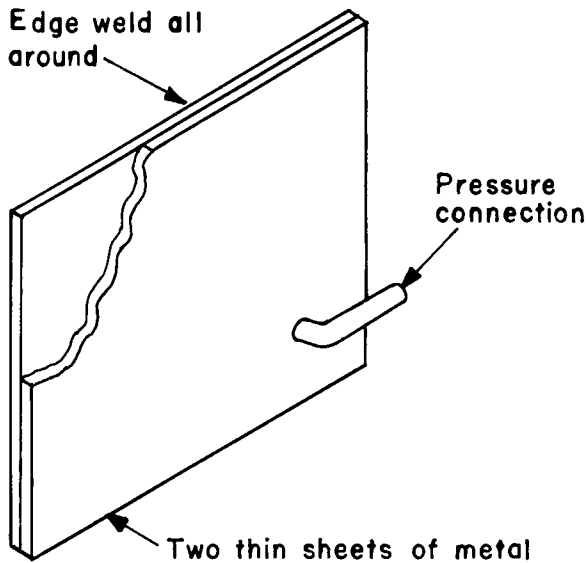

An air pillow will provide constant pressure for holding a workpiece. The envelope or pillow is formed by edge welding two identical sheets of thin metal to make a continuous seal around its edges. At a convenient lower corner, a small diameter tube is brazed or welded into the pillow to supply air pressure. When air pressure is applied, it causes a proportional expansion of the air pillow. The expanded pillow provides controlled clamping or holding of a workpiece against any appropriate adjacent form or surface. These air pillows are also quite frequently used in pairs.

*SOURCE:* Lewis Research Center (Lewis-33)

## LAPPING SPOTFACES

**THE PROBLEM:** To lap spotfaces of 0.218-inch diameter and 0.0002- to 0.0004-inch deep coaxial with air nozzles 0.018-inch in diameter.

## SOLUTION

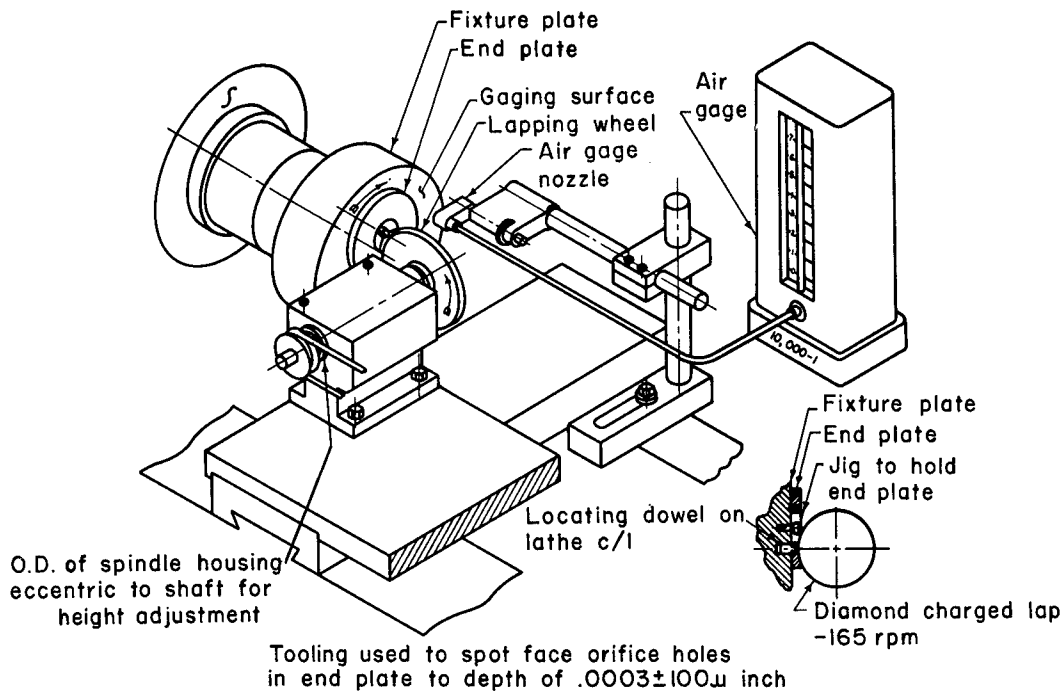

A lapping machine employing the radial lap principle eliminates metal chapping, structural fracturing, and the spiral pattern produced by single-point tooling. The sketch shows an attachment which may be made with materials available to any shop. Care must be exercised to obtain a true-running spindle. The lapping wheel is made of meehanite (cast iron). Its thickness is equal to the diameter of the desired

spotface. It should be turned and lapped on its own bearings for the truest possible surface. Operating speeds are 625 rpm for the lathe spindle and 165 rpm for the lapping spindle.

*NOTE:* This method produces a spotface with edges that blend into the surrounding surface.

*SOURCE:* George C. Marshall Space Flight Center (M-FS-92)

### IMPROVISED EXPANDING MANDRELS

**THE PROBLEM:** To hold hollow workpieces with inside diameters that are too small to be held with standard expanding mandrels.

#### SOLUTION

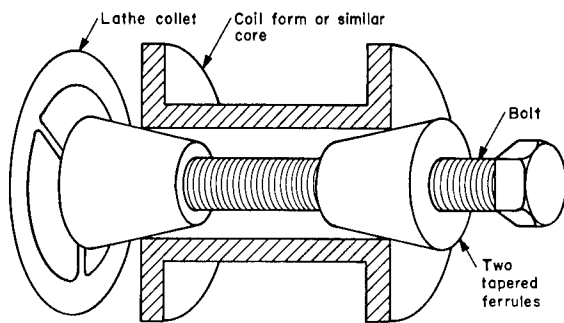

Tapered ferrules can be used as expanding mandrels. The sketch shows how the ferrules are mounted on a bolt and drawn tight by a lock nut. The bolt is then chucked up in the lathe with a standard type draw collet.

*SOURCE:* Lewis Research Center (Lewis-150)

## UNIVERSAL LATHE AND JIG BORE FIXTURE HOLDER FOR PRECISION MACHINE WORK

**THE PROBLEM:** To standardize setup methods and procedures for both the lathe and jig bore, to improve the accuracy of machined parallel parts, and to save time.

### SOLUTION

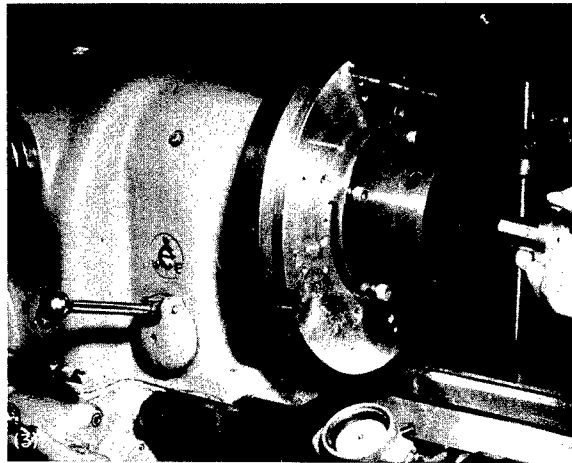
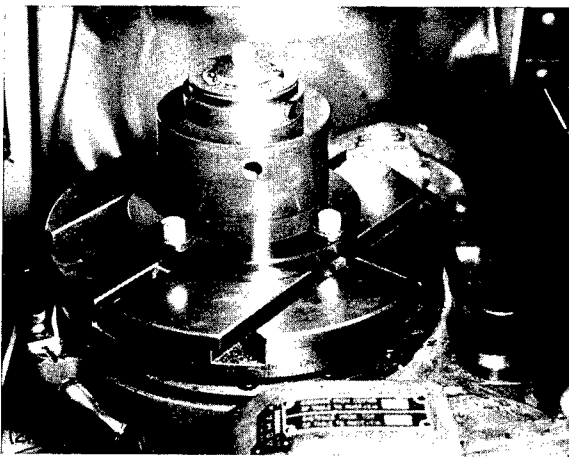
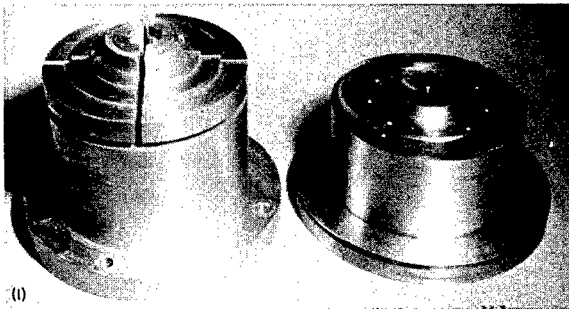

inch. A 1-inch hole is centered in each fixture perpendicular to the end faces. The holes should be sized and lapped to within 20 millionths of an inch of each other. A  $\frac{3}{8}$ -inch set screw should be provided in the side of each fixture.

The fixtures can be made of aluminum and hard-anodized for wear. Brass inserts to fit the holes with 1 to 2 ten-thousandths clearance can be made in various ways. Their construction is determined by the parts they are to hold. The photographs show the construction of the fixtures and the fixtures mounted in a lathe and jig bore.

*SOURCE:* George C. Marshall Space Flight Center (M-FS-151)

Construct highly precise identical fixtures which may be mounted on various machines. Duplicate fixtures are made with their end faces lapped parallel to within 10 millionths of an

**SECTION 7**

**PRECISION TOOLS**

	<i>Page</i>
DEVICE TO DETERMINE DEVIATION FROM PARALLEL... (W. J. Abernathy)*	57
MAGNETIC PROTRACTOR TO SPEED ANGLE SETTING ON MACHINE TOOLS.....	58
(Lester B. Vale)*	
GAGE FOR CHECKING CONNECTOR PIN INSERTION AND REMOVAL FORCE.....	59
(R. A. Stickley)*	
OPTICAL DEVICE TO INSPECT THE SEATING SURFACE OF FLARE TUBE FITTING.....	60
SQUARENESS AND PERPENDICULARITY TOOL.....	61
(Edwin White)*	
SPINDLE CENTER LOCATING.....	63
(John Rietman)*	

---

\* Innovator.

### DEVICE TO DETERMINE DEVIATION FROM PARALLEL

**THE PROBLEM:** To provide a means for accurate and economical determination of parallelism of air bearing end plates in the shop.

#### SOLUTION

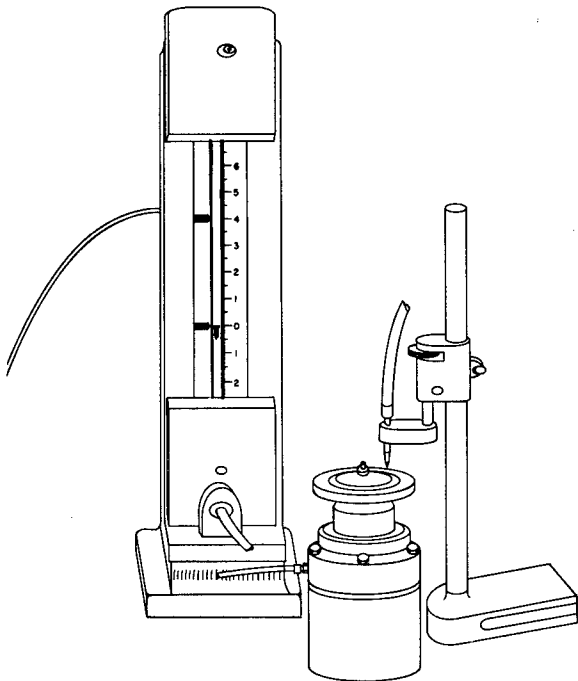

An instrument that will give direct readings of deviation from parallel can be easily fabricated with an air bearing, an air gage, and a cylinder. The cylinder has its top serrated for use as a table. Reference can be made to the sketch for construction details. The air bearing and the cylinder are made of hard-anodized aluminum for wear resistance, and they are lapped so that the cylinder will float in the bearing. The top surface of the cylinder is lapped perpendicular to the cylinder centerline, within 10 millionths of an inch. Parts that are to be measured are secured to the table and rotated slowly under an air gage pickup. This gives direct readings of deviation from parallel on a 10,000 to 1 Sheffield air gage.

**NOTE:** Measurements of parallelism to 10 millionths of an inch can now be made using this device. This can be done easily and in about one-fifth of the time required to measure the same part directly on a Cleveland Indi-Ron (actual measuring time).

**SOURCE:** George C. Marshall Space Flight Center (M-FS-111)

## MAGNETIC PROTRACTOR TO SPEED ANGLE SETTING ON MACHINE TOOLS

**THE PROBLEM:** To develop a method for checking or setting angles on machine tools which is not time consuming and which will not present difficulties when the machine tools are in remote areas or are of complicated configuration.

### SOLUTION

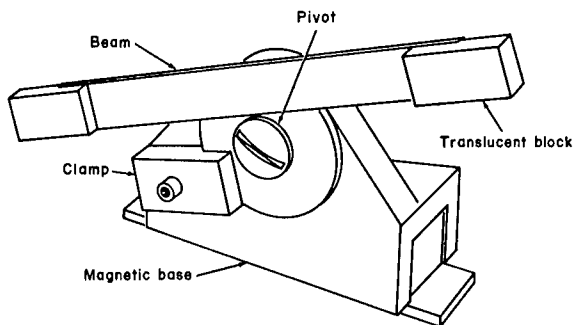

Angles may be checked or set with an adjustable protractor. This device has a magnetic base to facilitate its attachment to a reference surface on the machine. The protractor also incorporates a beam, about 6 inches long, mounted on a pivot about which the beam can be rotated to any desired angle with respect to its magnetic base.

The angle to be transferred is first established by some conventional method; at Ames Research Center, a contour projector is used, but less expensive methods may be substituted. The movable beam on the protractor is adjusted

until its shadow coincides with the image on the screen of the projector. Translucent blocks on the ends of the beam may be tapped by the operator to obtain fine settings. The beam is then clamped in position, and the setting can be rechecked. After rechecking, the angle is transferred to the machine tool.

Angles are easily transferred to remote machine tools or surfaces on which a sine bar and gage blocks cannot be easily used. The setup is accomplished in a fraction of the time required for conventional methods.

### NOTES:

1. The protractor can transfer angles within an accuracy of 1 minute of arc.
2. A very simple modification to this protractor configuration used at Ames (calibrating the distance between the center of rotation and one end of the beam) would be needed to allow the protractor to be set to the desired angle with gage blocks and permit its use in shops that do not have a contour projector or a comparator.

*SOURCE:* Ames Research Center (ARC-5)

## GAGE FOR CHECKING CONNECTOR PIN INSERTION AND REMOVAL FORCE

**THE PROBLEM:** To measure the force required to connect and disconnect connector pins directly during inspection rather than indirectly by dimensional inspection.

### SOLUTION

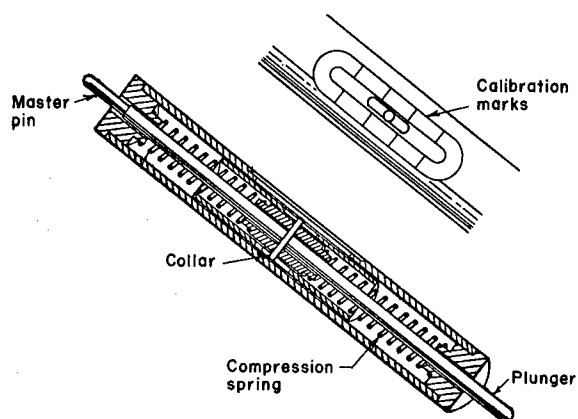

Use a simple shop-made force indicator to inspect each female connector in one simple operation. The construction of the device is

shown in the illustration. A collar, carrying a pointer, is mounted at the midpoint of a plunger. The compression springs on each side of the collar provide a constant resistance to movement of the plunger. One end of the plunger is threaded to take a master pin which has been carefully machined to the low tolerance of the pins under consideration. The internal assembly is then inserted in a tube approximately the size of a mechanical pencil. The final step is to calibrate the tool to the required forces in both directions. When the tool is inserted into a female connector, the tool will indicate insertion force, and, upon removal, it will indicate withdrawal force.

*SOURCE:* Jet Propulsion Laboratory (JPL-568)

## OPTICAL DEVICE TO INSPECT THE SEATING SURFACE OF FLARE TUBE FITTING

**THE PROBLEM:** To devise an easy means for inspecting the seating surface of flare-type tube fittings.

### SOLUTION

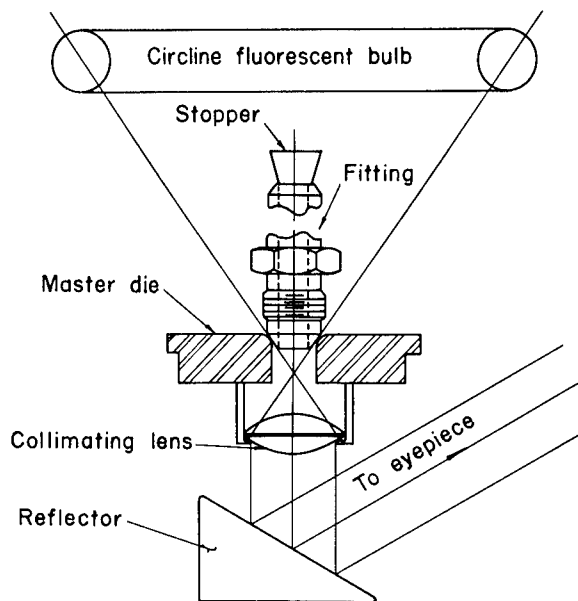

(1)

An optical device which will give visual evaluation to 0.0001 inch has been constructed. A similar instrument can be made from the sketch. Component sizes must be determined by the sizes of the fittings to be inspected. The optical pieces can be selected from whatever stock is available.

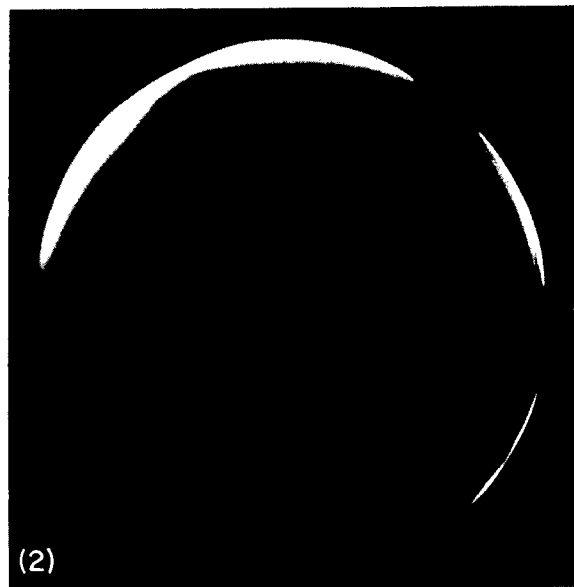

### NOTES:

1. This instrument is for evaluation of eccentricity only; it is not for the evaluation of surface finish, statistical evaluations, and the like.
2. The photograph illustrates a typical defective fitting.

*SOURCE:* George C. Marshall Space Flight Center (M-FS-141)

**SQUARENESS AND PERPENDICULARITY TOOL**

**THE PROBLEM:** To measure squareness and/or perpendicularity of workpieces within 0.0001 inch. The range of workpiece sizes is from 1/2 to 10 inches.

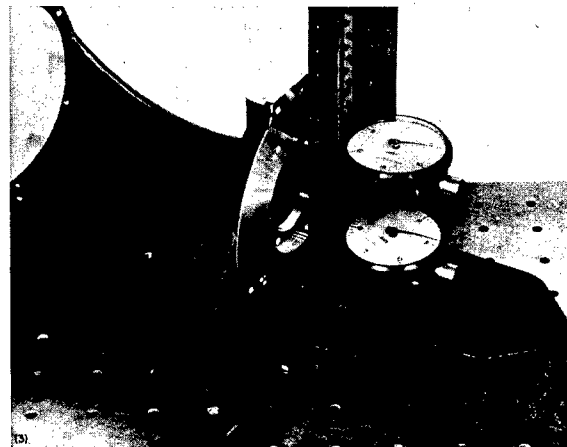
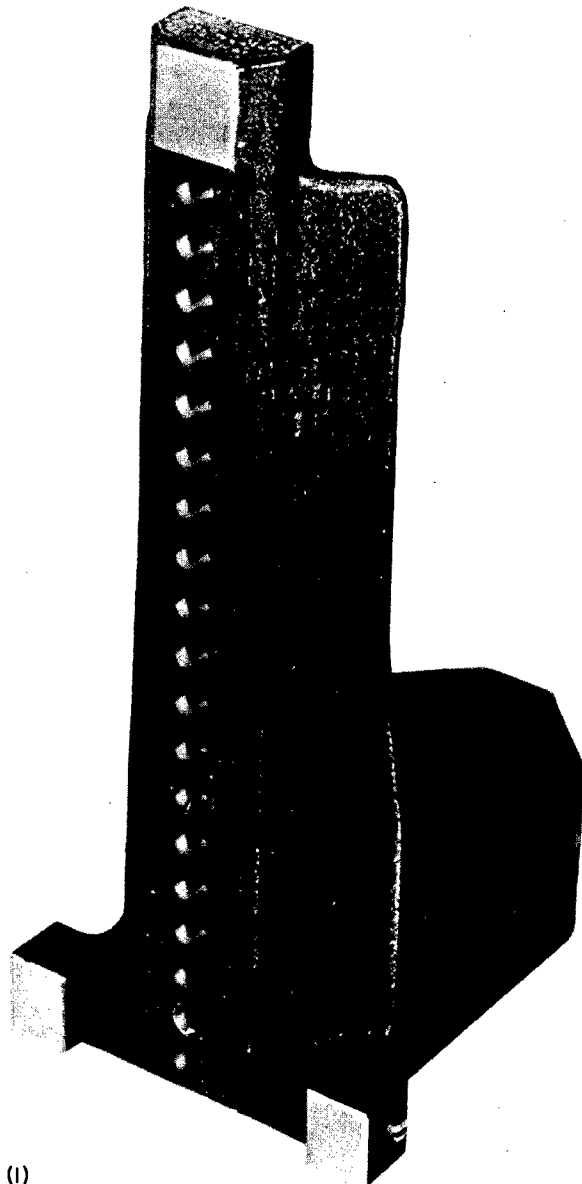
**SOLUTION**

A special device utilizing two dial indicators can be used to determine slight angles. Figure 1 shows the tool body in a vertical position. A capable machinist can construct a similar body with the materials and methods that are avail-

able to him. Both the base and the side of the body are equipped with three pads which are ground to establish the inherent squareness of the tool. The holes for the dial indicators are spaced  $\frac{1}{2}$  inch apart.

Figure 2 illustrates the setting of the tool. The indicators are secured in place, with set screws, and their dials are zeroed. The device is then set upright and it is ready for use.

Figure 3 shows the device brought into contact with the work. The difference between readings of the two dials, divided by the distance between the dials, will give the sine of the angle.

*NOTES:*

1. This instrument eliminates all vertical movement, and it can be set in  $\frac{1}{2}$ -inch vertical increments up to 10 inches.
2. Slight angles can be measured, but this instrument was not designed for extremely accurate measurements requiring accuracy to fractions of a second of arc.
3. This instrument may be used in any machine or tool making shop where squareness and/or perpendicularity measurements, accurate to .0001 inch, are required.

*SOURCE:* George C. Marshall Space Flight Center (M-FS-107)

### SPINDLE CENTER LOCATING

**THE PROBLEM:** To accurately locate the center of a machine tool spindle. Precision machine work requires accurate setting of workpieces relative to the spindle of the machine. The method described here will prove more convenient in many cases than the usual wiggler or button methods.

#### SOLUTION

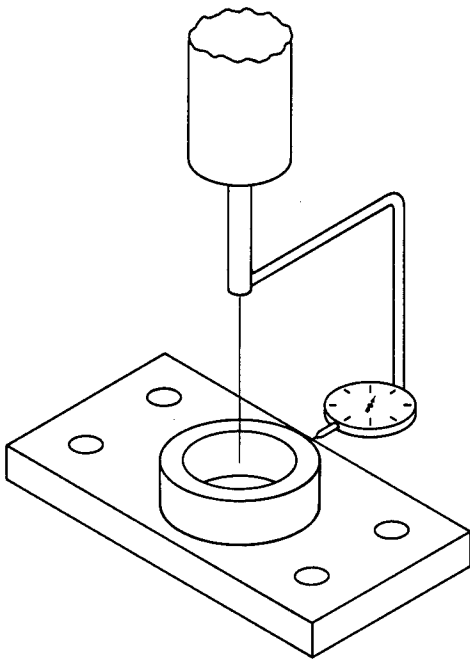

A cylinder of precise inside and outside diameters is fabricated with its axis perpendicular to a base. The tool shown in the sketch has an inside diameter of 1.0000 inch and an outside diameter of 1.5000 inches. Suitable holes are provided to mount the tool on the machine table or workpiece. A dial indicator is mounted in the spindle, and the table of the machine is adjusted to obtain a zero reading on the indicator during a full rotation of the spindle. The spindle is then raised to allow the indicator to clear the tool. The machine table is advanced until the indicator shows a zero reading against a reference surface on the workpiece. The center of the spindle will then be precisely one-half the diameter of the tool away from the reference surface.

*SOURCE:* Ames Research Center

## SECTION 8

### SPECIAL TOOLS

	<i>Page</i>
SUBMINIATURE CONNECTOR SEPARATOR.....	67
GENERATION OF VARIABLE LEAD HELIX ON A CONIC OR CYLINDRICAL SURFACE.....	68
(John W. LeMay and W. Angele)*	
VIBRATING ELECTRIC ARC FOR METAL SURFACE ROUGH- ENING.....	70
(Carl W. Richter and Bernard H. Smith)*	
PRINTED CIRCUIT CLEANING TOOLS.....	71
(Isaac Whitworth)*	
RIGHT-ANGLE SCREWDRIVER.....	72
(John McKiernan, Joseph O'Connor, and John Kosoloski)*	
CONNECTOR REMOVAL TOOL.....	73
(Wallace B. Pierce)*	
TERMINAL PUNCH.....	74
(George B. Robinson)*	
RESEATING TOOL FOR FLANGED TUBE FITTINGS.....	75
(Robert R. Ballard)*	
COTTER PIN TOOLS.....	76
(Fred W. Lucht, Jr.)*	
TUBE END DEBURRING TOOL.....	77
(C. Headley, V. Padilla, and R. Schoppman)*	
MICRO-MANIPULATION TOOL.....	78
(Paul J. Shlichta)*	
AIR-ABRASIVE CUTTING EDGE.....	79
(H. Copas and F. Macuga)*	
TUBE FLARE INSPECTION GAGE.....	80
MODIFIED SPRAY GUN TO ELIMINATE QUICK-HARDENING PROBLEMS IN PLASTIC SPRAYS.....	81
(Oce W. Johnson)*	
SPECIAL PLIERS TO CONNECT HOSE CONTAINING LIQUID UNDER PRESSURE.....	82
(Richard A. Blaydes)*	
BOLT AND SCREW CUT-OFF TOOL.....	83
(Harold L. Tuck)*	

\*Innovator(s).

### SUBMINIATURE CONNECTOR SEPARATOR

**THE PROBLEM:** To disengage cannon connectors quickly and without damage. It has been the procedure to disengage cannon connectors by direct pulling on the connectors by hand. This is extremely difficult, especially with a 25- or 50-pin connector. Connectors have also been disengaged by pulling on the harness and by wedging a screwdriver between mating connectors. Obviously, these procedures result in damage to connectors, harnesses, and nearby equipment.

#### SOLUTION

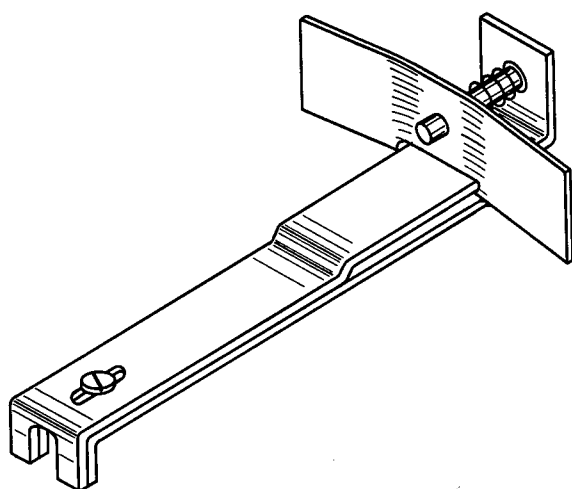

A simple tool has been devised which disengages cannon connectors quickly and without damage.

In operation, the tool is slipped between connector flanges and squeezed, utilizing leverage to disengage connectors.

*NOTE:* This device can be modified for use with other connectors.

*SOURCE:* Radio Corporation of America (GSFC-174)

## GENERATION OF VARIABLE LEAD HELIX ON A CONIC OR CYLINDRICAL SURFACE

**THE PROBLEM:** To generate lead helix without the use of expensive machinery.

### SOLUTION

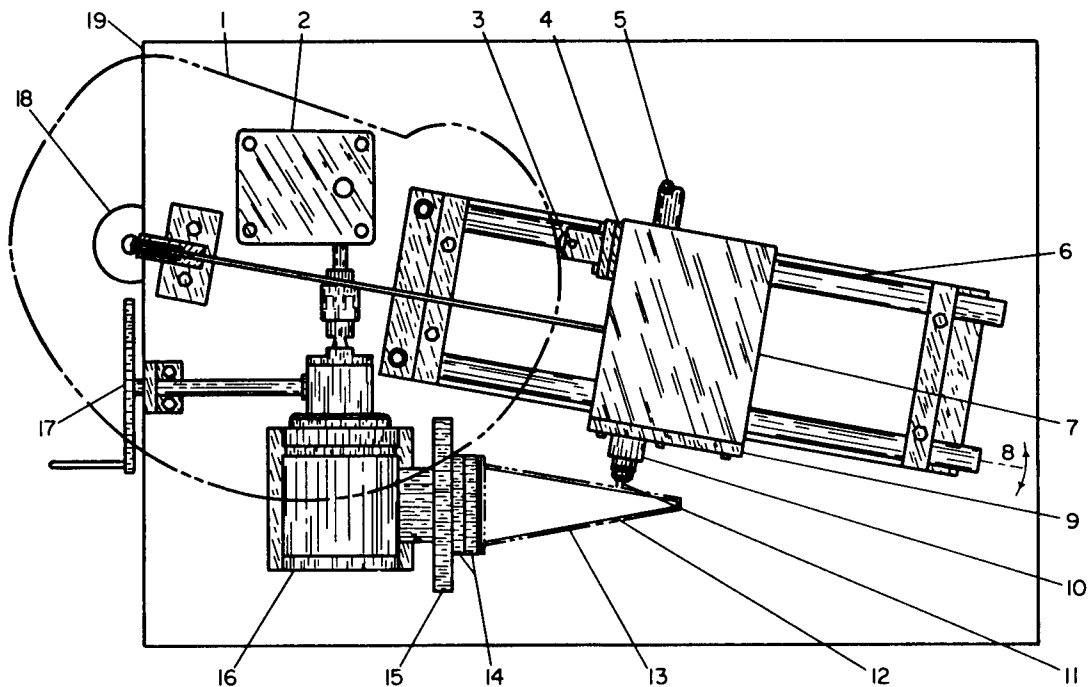

- |  |                                      |
|--|--------------------------------------|
| 1. Cam, to suit desired helix                  | 11. Routing tool to suit groove      |
| 2. Boston Gear Co. 40:1 reducer                | 12. Mandrel                          |
| 3. Cam follower                                | 13. Rexolite coil form               |
| 4. Spacing shim to suit helix length           | 14. Index plates for multiple leads  |
| 5. Flexible shaft to drive tool, 15,000 rpm    | 15. Face plate                       |
| 6. Carriage ways                               | 16. Hardinge dividing head 4:1       |
| 7. Tool carriage                               | 17. 10:1 ratio $\times$ 40:1 on cone |
| 8. Adjusted parallel to face of cone           | 18. Counterweight                    |
| 9. Movable plate for height adjustment of tool | 19. Base plate                       |
| 10. Routing spindle with depth control         |                                      |

A special machine employing a high speed router type tool to cut the helix has been developed. As shown in the illustration, this machine uses a variable cam (1) that rotates about the shaft of a 40:1 reduction gear box (2). As the cam is rotated, it causes the cam follower (3) to move the tool carriage (7) on adjustable carriage ways (6). The tool carriage, which is

counterweighted (18) to keep the cam follower against the cam, carries a special routing tool on a routing spindle which has a depth control. The Rexolite conical coil form (13) is mounted on a conical mandrel (12) which has its surface parallel to the adjustable carriage ways. The mandrel is mounted to the index plates (14) which are, in turn, mounted to the face plate

(15). The face plate is mounted to a Hardinge dividing head gear box with a 4:1 ratio (16). By rotating the hand crank (17), the cone is rotated 10 times for every revolution of the cam. Utilizing this mode of operation, a helix or spiral may be cut in the surface of a cone or cylinder to any predetermined variable or constant lead by simply changing the contour of the cam and adjusting the carriage ways.

*NOTES:*

1. This machine could be used in the manufacture of a worm-type control mechanism for a variable speed drive and also of a feed cam mechanism for a screw machine.
2. With this particular machine, the helix cannot exceed 10 revolutions.

*SOURCE:* George C. Marshall Space Flight Center (M-FS-108)

### VIBRATING ELECTRIC ARC FOR METAL SURFACE ROUGHENING

**THE PROBLEM:** To eliminate electrode sticking and surface damage in electric arc etching.

#### SOLUTION



A vibrating arc tool with an air-cooled electrode can be used for etching sheet metal. The photograph shows an electrode attached to an electric razor to obtain the desired vibrating motion. A simple nozzle is also mounted on the razor to direct a blast of cooling air on the work. A secondary line of cooling is directed into the vibrator (razor).

*NOTE:* It has been suggested, but not as yet adopted, that the etching electrode be made hollow so that cooling air may be forced through it to the work. With this device, the surface of thin sheet metal can be quickly and effectively roughened.

*SOURCE:* Lewis Research Center (Lewis-32)

### PRINTED CIRCUIT CLEANING TOOLS

**THE PROBLEM:** To prevent harmful alloying of gold and solder on printed circuit boards, the gold plating must be removed from the terminals before soldering.

#### SOLUTION

Type I

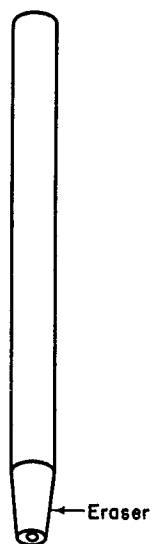

Type II

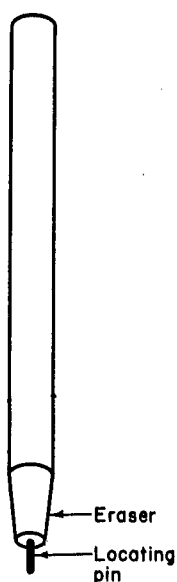

A simple tool employing an eraser can be used for cleaning printed circuit terminals. Abrasive rubber erasers are cemented to rods as shown in the sketch. The eraser on type I has a hole in it to fit down over a pin or connector. Type II has a locating pin to insert in a lead hole on the circuit board. This tool can be operated manually, by a hand electric drill, or by a drill press.

*SOURCE:* George C. Marshall Space Flight Center (M-FS-158)

### RIGHT-ANGLE SCREWDRIVER

**THE PROBLEM:** To reach certain instrument adjustment screws without partially disassembling the instrument.

#### SOLUTION

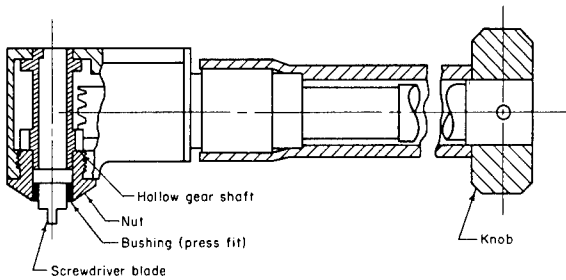

Trim the head of a dental drill down to the smallest possible size. This will require modi-

fication of the blade-holding mechanism. Shorten the hollow gear shaft and press a bushing into the nut, as shown on the sketch. The screwdriver blade should be made with a shoulder to fit between the hollow gear shaft and the bushing. The nut is removable with a pin or spanner wrench and permits the use of interchangeable screwdriver blades. Add a knob to the drive shaft for manual operation.

*SOURCE:* Goddard Space Flight Center (GSFC-255)

**CONNECTOR REMOVAL TOOL**

**THE PROBLEM:** To disconnect a multiterminal connector from its mate without damaging the flanges of the connector.

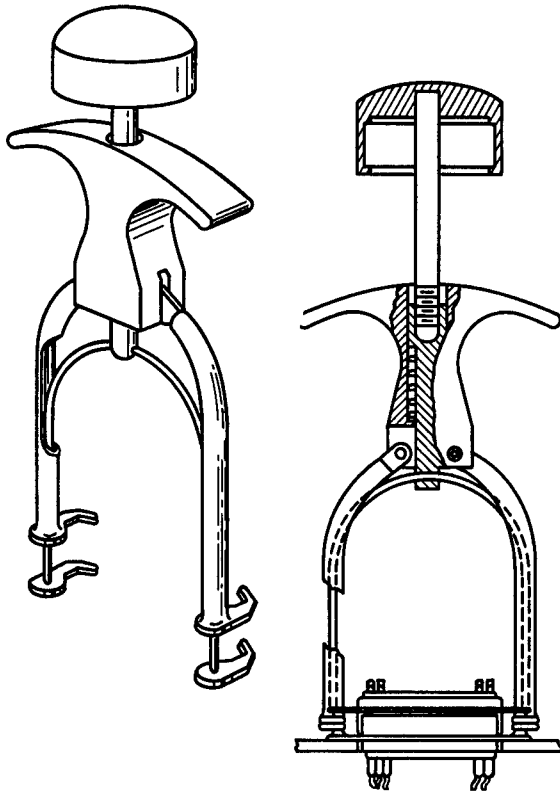
**SOLUTION**

The tool shown in the sketches can be used to disengage two connectors without damaging or applying excessive strain on either connector. Because the legs of the tool are mounted on pivots, the tool is adaptable for use on a wide variety of connector widths. The various parts of the tool can be modified to suit the materials available.

*SOURCE:* Jet Propulsion Laboratory (JPL-448)

### TERMINAL PUNCH

**THE PROBLEM:** To speed up and facilitate the staking of terminals in punched boards.

#### SOLUTION

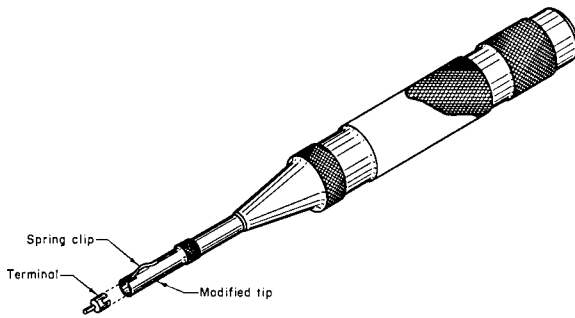

Make a special tool by modifying a common hand-operated center punch as shown in the illustration. A hole is drilled in the tip to accept the terminal. To use it, insert a terminal in the hole in the punch, and then locate the terminal on the punch board. To stake the terminal firmly, operate the punch in the same manner as for normal center punching.

*SOURCE:* Goddard Space Flight Center (GSFC-43)

### RESEATING TOOL FOR FLANGED TUBE FITTINGS

**THE PROBLEM:** To eliminate costly and time-consuming lathe setups or make-do substandard field methods when reseating flanged tube fittings.

#### SOLUTION

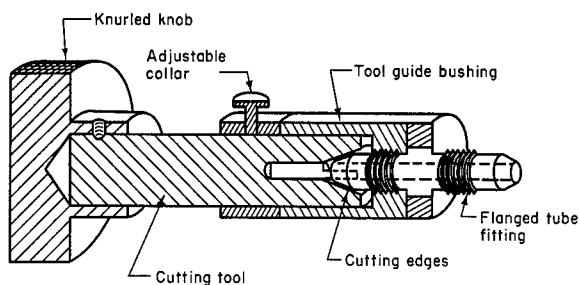

A tool guide bushing is threaded to fit the male tube fitting. The cutting edges of the tool are ground to the prescribed flare angle. The cutting action is smooth and cutting edges are easily sharpened. A simple reamer is inserted to clean the hole in the fitting. The adjustable collar on the cutting tool limits the depth of cut. The knurled knob permits easy turning of the cutting tool.

*SOURCE:* Flight Research Center (FRC-15)

### COTTER PIN TOOLS

**THE PROBLEM:** To spread and remove cotter pins located in not easily accessible places.

#### SOLUTION

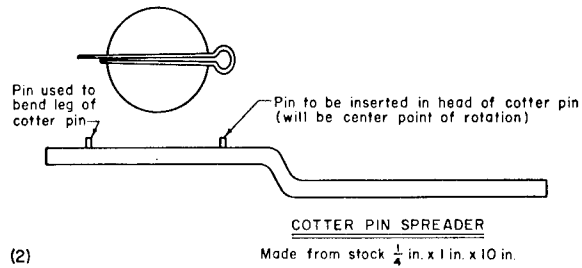
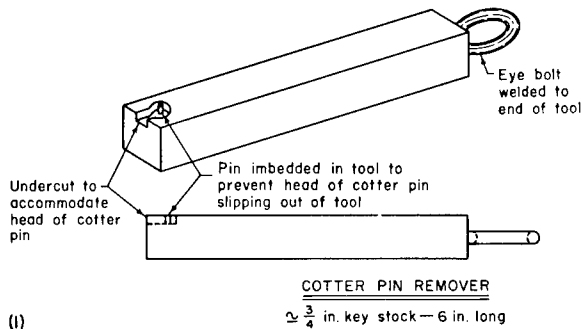

Two special tools are made to do the job, a cotter pin remover and a cotter pin spreader. The cotter pin remover is simply shaped to securely grasp the head of the cotter pin so that it can be pulled out of the shaft. The cotter pin remover will work with several sizes of cotter pins. A different cotter pin spreader

must be made for each size of cotter pin used. The one pin fits into the head of the cotter pin to act as a center of rotation. The second pin is located on the tool so as to act against the longer leg of the cotter pin and bend it outward as the tool is rotated.

*SOURCE:* Lewis Research Center (Lewis-44)

### TUBE END DEBURRING TOOL

**THE PROBLEM:** To develop a tube deburring tool which will not leave metal chips inside the tube. This metal scrap tendency is present in most tools of this type, but it is objectionable and cannot be tolerated in quality fluid systems.

### SOLUTION

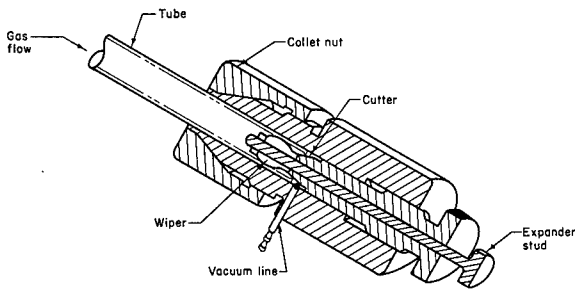

The problem can be eliminated by constructing a relatively simple tool which retains the chips near the end of the tube until deburring is finished. After a tube has been cut off, the tool is slipped over the end of the tube and secured in place by tightening the collet nut. The wiper is expanded to seal off the tube by turning the expander stud. Rotating the tool removes the burrs from the tube end. As the tool is withdrawn, the chips are removed by a wiper action combined with a forced air flow and a vacuum system.

*SOURCE:* Manned Spacecraft Center (MSC-28)

### MICRO-MANIPULATION TOOL

**THE PROBLEM:** To manipulate easily electronic micro-miniature components, such as filaments and crystals.

#### SOLUTION

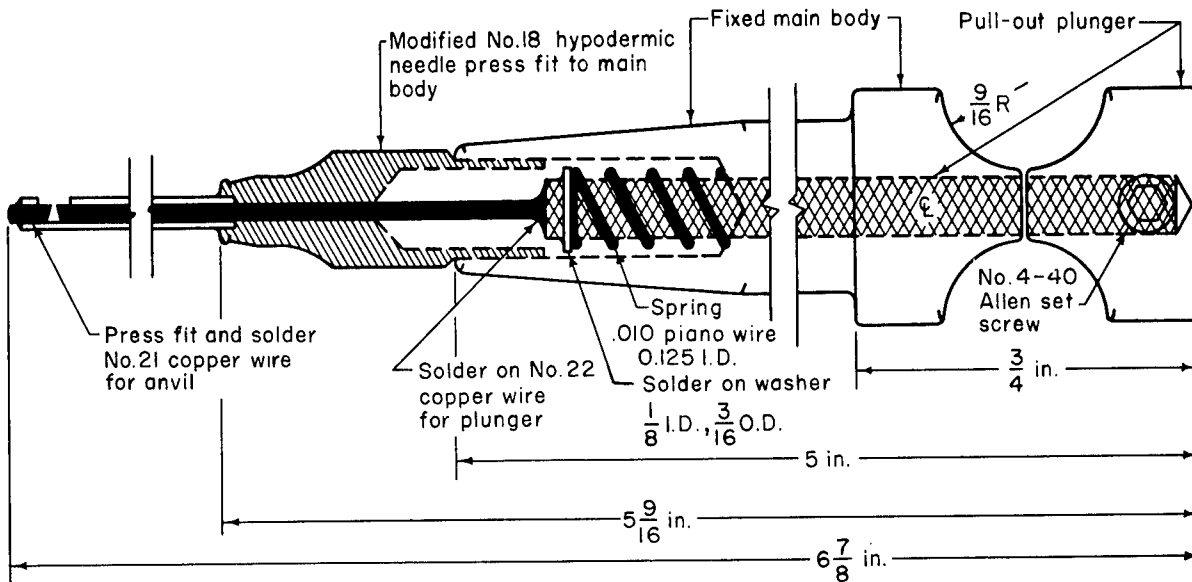

A special tool for handling micro-miniature components can be easily made with available parts. The tool can be modified for cutting, clamping, spot welding, and such. One version of the tool is shown in the sketch. In this case, it is spring loaded for clamping. The spring may be repositioned so that clamping takes

place only when the plunger is depressed. The plunger may be made from a camera release cable if flexibility is desired. Different tip designs can be utilized for various applications. *SOURCE: Jet Propulsion Laboratory (JPL-129)*

### AIR-ABRASIVE CUTTING EDGE

**THE PROBLEM:** To cut circular holes in brittle materials, such as glass, without the usual high rate of breakage or the long setup time.

### SOLUTION

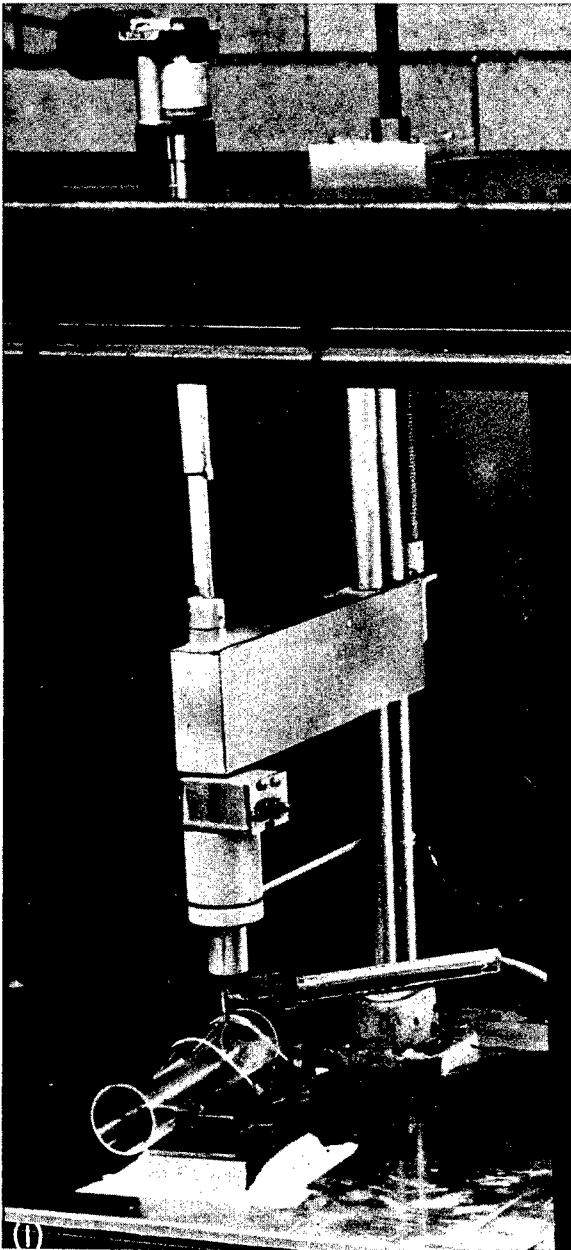

An automatic air-abrasive cutting device will eliminate breakage and decrease the time re-

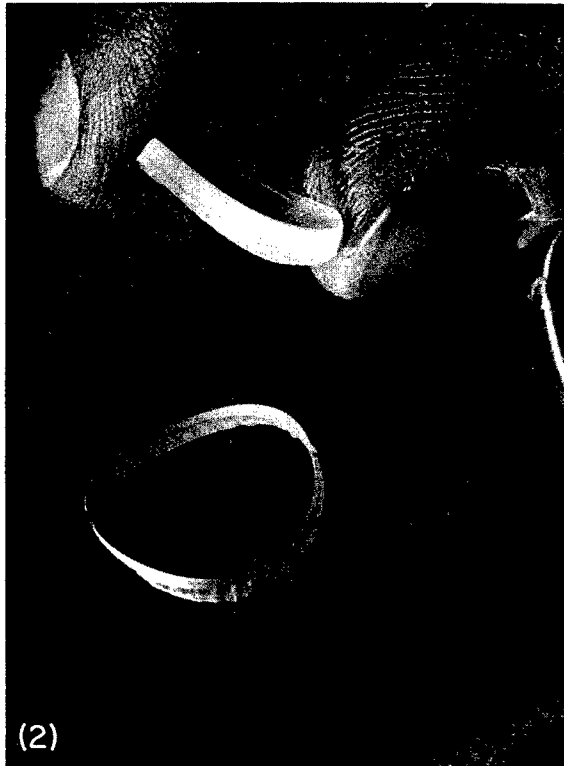

quired to cut plate glass, glass tubing, and such. Such a tool was adapted to an automatic positioning jig and containing box. With planetary gearing on the cutter, automatic cutting is possible after setting the hole size and positioning the work. Round holes are easily obtained without ragged edges.

#### NOTES:

1. The principle of this innovation is the adaptation of an automatic positioning jig and containing box to an air-abrasive cutting tool.
2. This device could be modified with a pantograph for odd-shape cutting.

*SOURCE:* Lewis Research Center (Lewis-3)

### TUBE FLARE INSPECTION GAGE

**THE PROBLEM:** To inspect tube flares quickly and effectively for acceptable tolerance limits.

#### SOLUTION

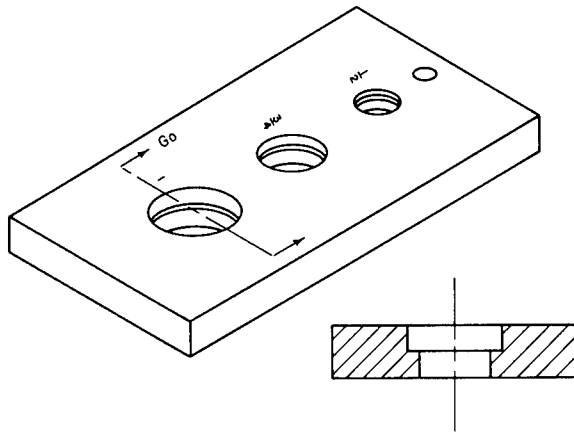

Design simple GO-NO GO gage for checking tube flares. To accomplish this, a series of holes representing the various AN tube sizes is bored in a steel plate about  $\frac{1}{2}$  inch x 3

inches x 10 inches. Each hole is stepped with the larger diameter sized to the GO condition and the smaller diameter sized to the NO GO condition. Tube sizes are indicated at each hole, and the GO and NO GO sides are identified.

**NOTE:** Limits for the various tube sizes according to AND 10061 and MS 33584 are:

$\frac{1}{8}$ inch	0.190	0.200
$\frac{3}{16}$ inch	0.292	0.302
$\frac{1}{4}$ inch	0.349	0.359
$\frac{5}{16}$ inch	0.411	0.421
$\frac{3}{8}$ inch	0.474	0.484
$\frac{1}{2}$ inch	0.646	0.656
$\frac{5}{8}$ inch	0.771	0.781
$\frac{3}{4}$ inch	0.927	0.937
1 inch	1.172	1.187

**SOURCE:** NASA Flight Research Center

## MODIFIED SPRAY GUN TO ELIMINATE QUICK-HARDENING PROBLEMS IN PLASTIC SPRAYS

**THE PROBLEM:** To prevent coating materials which consist of an admixture of plastic resins and certain additives (accelerators, catalysts, or hardening agents) from hardening prematurely and clogging the nozzle of a spray gun.

### SOLUTION

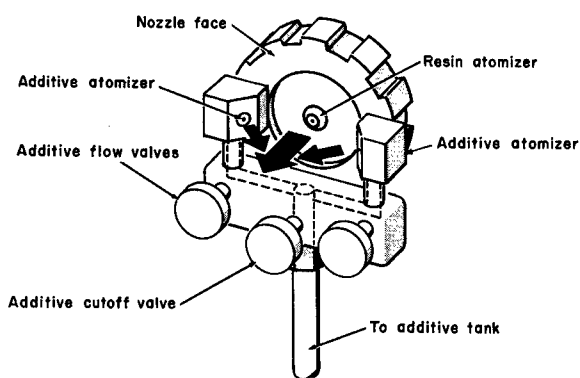

A modified spray gun with separate tanks and separate atomizers for resin and additive components will eliminate the hardening problem. As shown by the arrows in the illustration, the atomizers mix the liquids at the time of application. Two atomizer units for the additive are attached to the spray gun, one at

either side of the main (resin) nozzles. A tube from the additive container forms a Y-joint to supply both additive atomizers simultaneously. The device incorporates three needle valves, one valve for cutting the additive on or off and two valves (one in each branch) for adjusting the proportion of additive.

In operation, compressed air forces the resin out of the main nozzle and the additive out of the two side atomizers. The three sprays blend when they are  $\frac{1}{4}$  inch in front of the nozzle face.

### NOTES:

1. This device could be modified to mix three separate sprays from three separate tanks.
2. It could be useful for mixing colors in spray painting.

*SOURCE:* Langley Research Center (Langley-6A)

## SPECIAL PLIERS TO CONNECT HOSE CONTAINING LIQUID UNDER PRESSURE

**THE PROBLEM:** To manually and quickly connect large self-sealing, quick-disconnect fittings on a hose that is carrying fluid under pressure. The operator must cope with the pressure of the liquid, the spring pressure of the fitting, and the weight of the hoses. If the connection is not made quickly, the liquid can spray out in a hazardous manner.

### SOLUTION

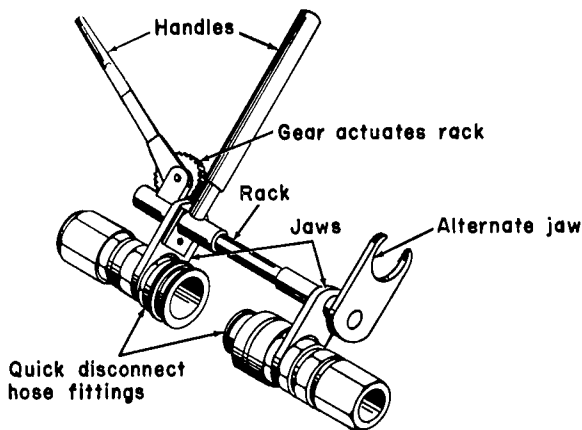

A special type of pliers, incorporating a gear and rack mechanism, and two or more wide-opening U-shaped jaws will quickly connect the fittings of a pressure hose with little or no leakage. In making a connection, one of the U-shaped jaws is placed over one of the hose fittings and the other jaw over the other hose fittings. After adjusting the pliers to bring the fittings close together, the operator squeezes the plier handles to make the connection. The leverage of the handles multiplies the force

exerted by the operator and easily overcomes the resistance encountered. Because the operator can force the fittings together quickly, there is little or no loss of fluid. An alternate larger jaw which can be swiveled and locked into place is provided on the pliers. The additional jaw facilitates the use of the tool with a variety of hose sizes.

### NOTES:

1. This device is recommended for any situation where large quick-disconnect fittings are to be joined.
2. Quick-disconnect fittings could be designed so that this mechanism would be an integral part of the coupling. Alternatively, the mechanism could be incorporated as a modification to existing fittings.
3. Adaptation of this principle to other operations in industry might be considered. For example, in welding or joining lightweight pipe, wrenches with oversize jaws would be distinctly useful.

*SOURCE:* Jet Propulsion Laboratory (JPL-IT-1003)

### BOLT AND SCREW CUT-OFF TOOL

**THE PROBLEM:** To shorten threaded fasteners quickly and without damage to the thread. Frequently, available threaded fasteners must be reduced in length to fit a particular requirement. Conventional methods to shorten threaded fasteners cause thread damage and the subsequent repair of the fastener is slow and frustrating.

#### SOLUTION

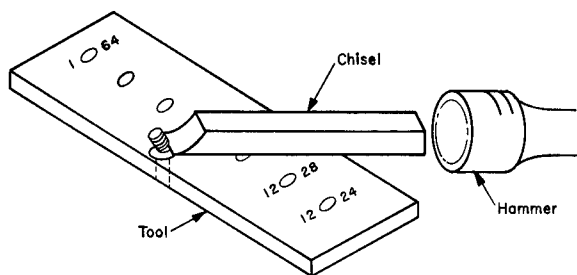

A simple tool can be constructed that will shorten fasteners quickly and without thread damage. For fasteners up to size 12, a piece of ground stock should be selected that is  $\frac{3}{16}$  inch x 1 inch x 6 inches. Holes should be drilled and tapped to accommodate the various fastener sizes. The tool should be heated to Rockwell 38-40. A chisel can be made from a  $\frac{1}{2}$ -inch x  $\frac{1}{2}$ -inch x 4-inch high-speed steel tool bit.

To shorten a bolt or screw, thread it through the plate until the unwanted piece is exposed; then hit it with a sharp blow from the chisel. When the screw or bolt is backed out of the plate, the plate acts as a die and straightens up the thread ends.

#### NOTES:

1. Fastener and thread sizes should be stamped on the tool to facilitate its use.
2. This tool can be drilled and tapped for the following common size fasteners:

1-64	2-56	3-48	4-40	5-40	6-32
8-36	10-30	12-28	2-64	3-56	4-
48	5-44	6-40	8-32	10-32	10-
24	12-24				

**SOURCE:** Lewis Research Center (Lewis-167)

**SECTION 9**  
**SPECIAL DEVICES**

	<i>Page</i>
FLEXIBLE FASTENER TO ALLOW THERMAL EXPANSION (Weymouth B. Crumpler)*	87
QUICK-RELEASE MECHANISM.....	88
(James W. Mayo)*	
SAFETY PIPETTE FOR USE WITH HAZARDOUS OR TOXIC FLUIDS.....	89
(Dwight G. McSmith)*	
PRECISION FORMING OF THERMOCOUPLE WIRE JUNC- TION.....	90
REMOVING SLUGS FROM GREENLEE PUNCHES.....	91
(Michael Pirics)*	
MAGNETIC SAW GUIDE.....	92
(Robert C. Fortenberry)	
REGULATING VALVE FOR FLEXIBLE TUBING.....	93
(John Malinkey, Jr.)*	
VACUUM BASE FOR MOUNTING DRILL PRESS.....	94
(John Cresap)*	
ECONOMICAL AND RELIABLE THERMOCOUPLE LEAD CON- NECTOR.....	95
(Howard B. Miller)*	
HYDRAULIC-PRESS INTENSIFIER.....	96
(Richard A. Terselic)*	
HIGH-VACUUM VALVE STEM MODIFICATION.....	97
(Michael J. Kalamas)*	

---

\*Innovator.

### FLEXIBLE FASTENER TO ALLOW THERMAL EXPANSION

**THE PROBLEM:** To provide a flexible, secure means of attaching skin sections for wind-tunnel research models. Thermal expansion of skin sections rigidly fastened to supporting structures produces stress which often causes the skin to rupture or buckle.

#### SOLUTION

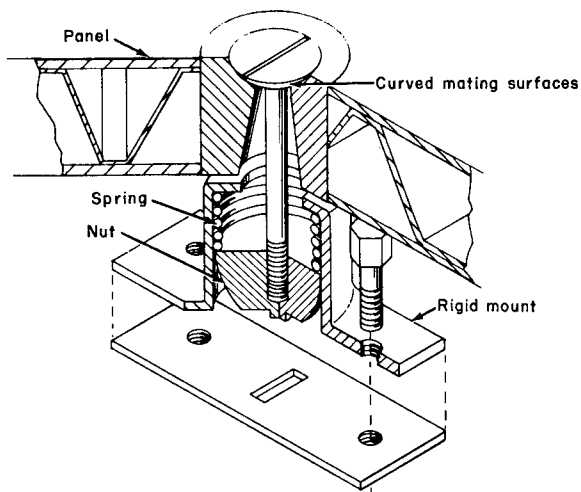

A flexible fastener that employs a modified ball joint contact between the fastener and skin section may be used to provide flexible, yet secure, attachment of skin sections. The con-

tact surfaces between the fastener head and skin section are mated to form a modified ball joint. This allows the skin section to move laterally without creating the large bending movements which would occur if the mating surfaces were flat. The threaded end of the fastener shank is secured to a spring-held nut housed in a rigid mount. A rectangular protrusion from the nut into a fixed slot prevents rotation during installation; however, this protrusion does not prevent wobble or vertical movement after installation.

*NOTE:* Although this fastener was designed to relieve thermally induced stresses, it may be used to connect two bodies wherein a provision for slight relative motion is necessary.

*SOURCE:* Langley Research Center (Langley—40)

### QUICK-RELEASE MECHANISM

**THE PROBLEM:** To reduce shock and fragmentation caused by the explosion of release devices. The principal disadvantage of the NASA diaphragm is its limited location in the structure and its dependency on subsequent rocket motor firing to accomplish separation.

### SOLUTION

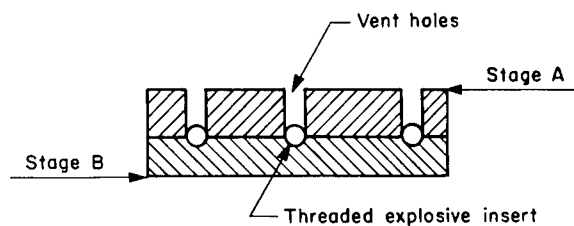

A quick-release mechanism with an explosive thread insert can be used to separate stages. Each of the stages to be separated has female threads or grooves cut into the mating surfaces. To assemble the two stages, a thread insert

made from a metal sheathed explosive, such as a mild detonating fuse, is fed into the female threads or grooves of the mating surfaces. To separate the two stages, the thread insert is exploded or detonated.

Previous devices have proven to be satisfactory, this innovation being merely another means of accomplishing separation. This innovation could be used as a remote separation device or find possible applications in drilling operations.

*SOURCE:* Langley Research Center (Langley-106)

### SAFETY PIPETTE FOR USE WITH HAZARDOUS OR TOXIC FLUIDS

**THE PROBLEM:** To develop a pipette that will allow an operator to utilize normal techniques and skills with hazardous or toxic liquids.

#### SOLUTION

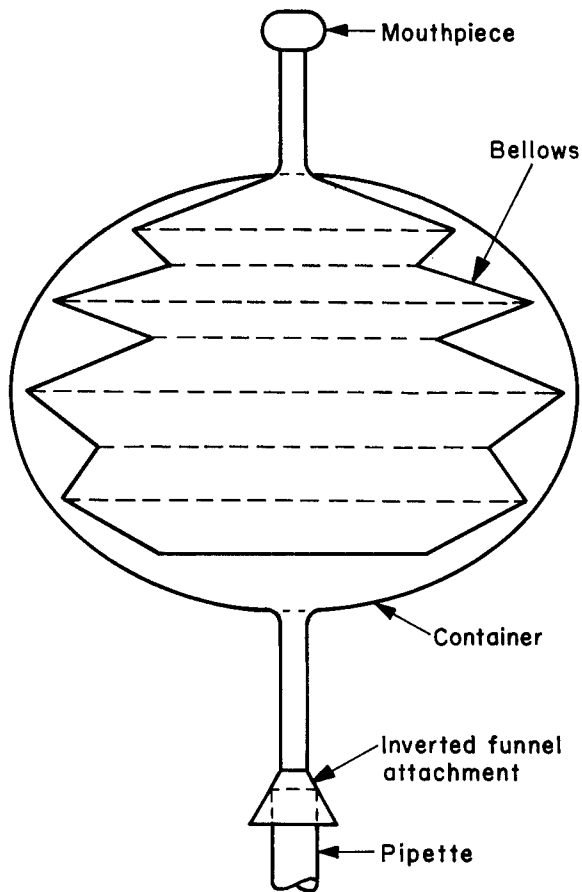

An ordinary pipette equipped with a special mouthpiece can be used safely with toxic fluids. The mouthpiece consists of a container with an elastic bellows mounted inside. The container and bellows are fabricated from a plastic material. The stem of the mouthpiece is shaped like an inverted funnel for ease of attachment to the pipette.

In operation, the mouthpiece is held in contact with the stem of the pipette and the bellows is deflated by mouth. When the pipette is filled, the mouthpiece is removed.

*SOURCE:* Langley Research Center (Langley-47)

### PRECISION FORMING OF THERMOCOUPLE WIRE JUNCTION

**THE PROBLEM:** To obtain a more perfect interface between wire ends at a thermocouple junction.

#### SOLUTION

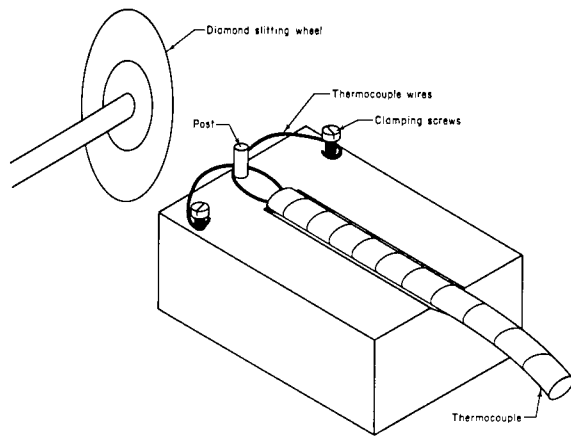

A special fixture will hold the wires while they are being cut. The fixture can be mounted on an instrument maker's lathe. The sketch shows the fixture whose actual dimensions are determined by the thermocouple size and the lathe cross slide. The thermocouple wires are passed around the post and secured with the clamping screws at the sides of the block. The slitting wheel cuts both wires at the same time; therefore, the wire ends are precisely matched for butt welding.

*SOURCE:* George C. Marshall Space Flight Center (M-FS-181)

### REMOVING SLUGS FROM GREENLEE PUNCHES

**THE PROBLEM:** To provide a means of quickly removing the slug from a greenless punch. Previously, it was necessary to pry out the slug with a screwdriver or other suitable tool.

#### SOLUTION

A compression spring may be inserted in the die of the punch to facilitate ejection of the slug without the use of outside tools.

*NOTE:* Obviously, it is necessary to use a different spring for each size greenlee punch.

*SOURCE:* Lewis Research Center (Lewis-9)

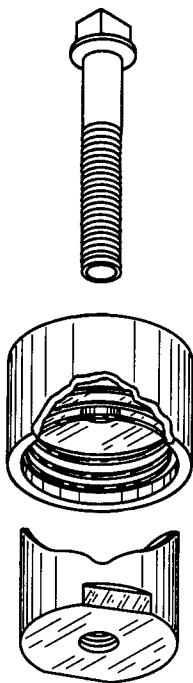

### MAGNETIC SAW GUIDE

**THE PROBLEM:** To develop an easily adjusted guide for cutting certain light-weight materials on a band saw.

#### SOLUTION

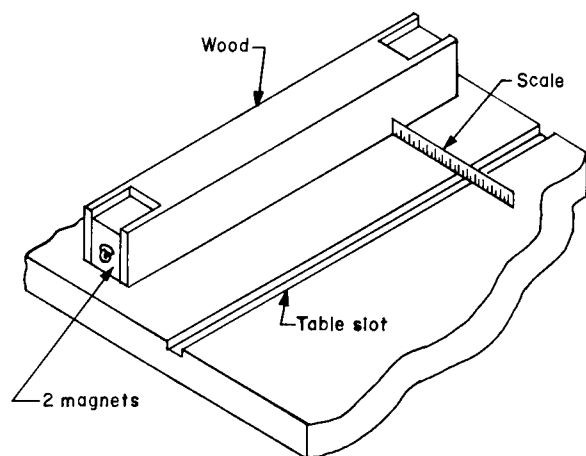

A band saw guide can be fabricated from a hardwood block approximately 3 inches square and 30 inches long. The block should have openings at either end for inserting two 90-degree polarized permanent magnets. The sketch suggests how the guide may be constructed. Setting the guide is accomplished by measuring against the table slot or other reference surface.

*SOURCE:* George C. Marshall Space Flight Center (M-FS-168)

## REGULATING VALVE FOR FLEXIBLE TUBING

**THE PROBLEM:** To find a trouble-free, low-cost regulating valve for use with flexible tubing gas line.

### SOLUTION

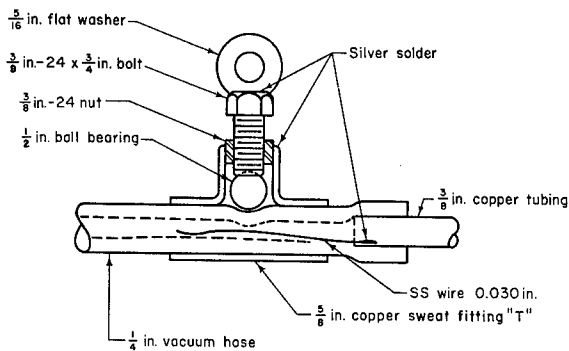

Use readily available standard items to fabricate such a valve. The illustration identifies the various parts that are used in assembling the valve. The 0.030-inch SS wire is used when metering gas flow at a pressure in the range of  $1 \times 10^{-4}$  to  $10^{-5}$  mm Hg.

*SOURCE* : Lewis Research Center (Lewis-168)

### VACUUM BASE FOR MOUNTING DRILL PRESS

**THE PROBLEM:** To drill precision holes in materials that are inaccessible to a drill press.

#### SOLUTION

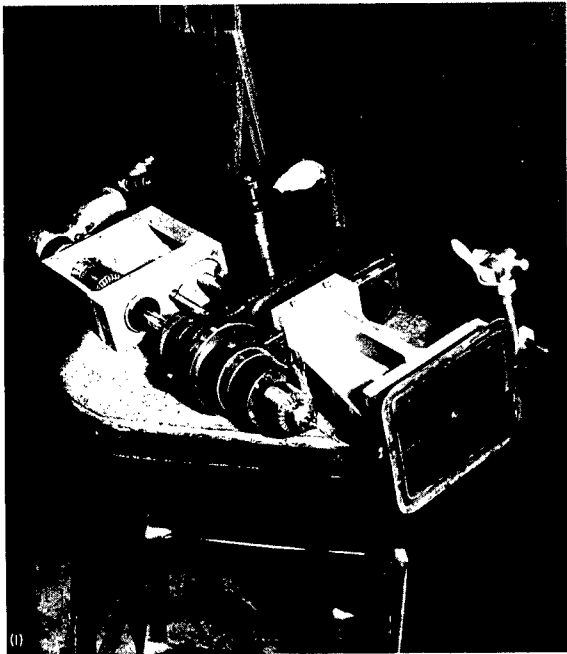

Modify a small drill press so that it can be used in any desired position. This is done by adding a bracket to support the drill motor in line with the spindle. Then, mount the head on a base fabricated of aluminum. Now add a vacuum shoe to the base, and the drill press is ready to use. A completed modification is shown in the photographs. The vacuum base will hold the drill stand securely to any smooth,

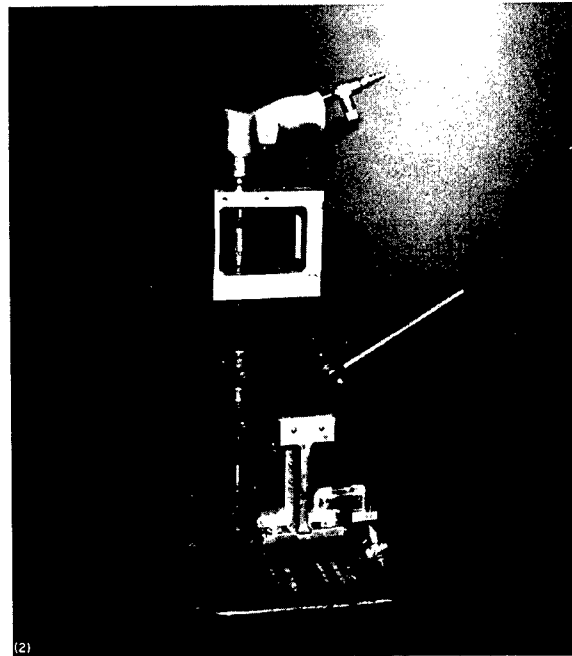

airtight surface, so long as there is sufficient clearance, without the necessity of other forms of clamps. A drill mounted in this manner has the advantage of allowing the operator to apply pressure on a drill bit, permitting it to take the proper bite; it also results in more accurately drilled holes than with a hand-held drill.

*SOURCE:* Marshall Space Flight Center  
(M-FS-19)

## ECONOMICAL AND RELIABLE THERMOCOUPLE LEAD CONNECTOR

**THE PROBLEM:** To provide a simple, reliable, and lightweight connection for use in thermocouple circuits.

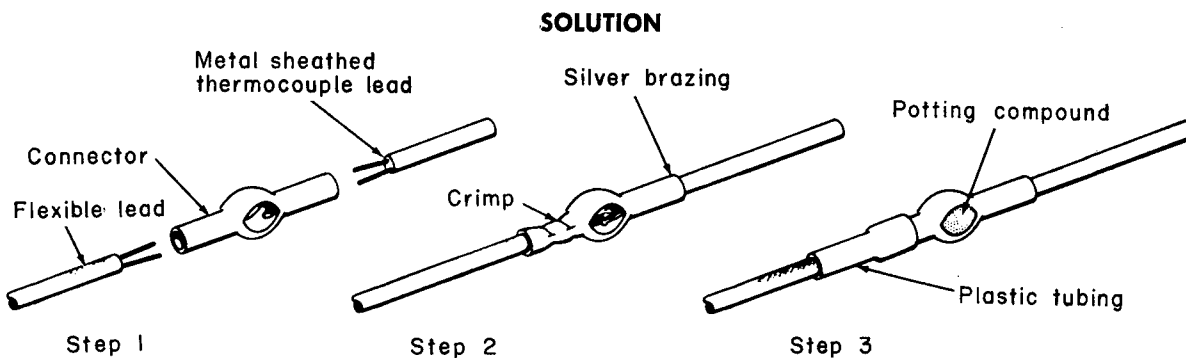

A special lightweight connector can be used to join wires in a thermocouple circuit. This connector has a central opening for joining wires and adding potting compound. Also, a technique for joining thermocouple wires has been developed. This technique assures good electrical contact, strong mechanical joints, and protection against moisture and corrosion. The metal-sheathed thermocouple lead and the flexible lead are inserted into one end of the connector. This end of the connector is then silver-brazed to the metal thermocouple sheath, and the other end of the connector is crimped over the insulation of the flexible lead. As further protection against abrasion and breakage, a small length of heat-shrinkable plastic tubing is secured over the crimped end of the connector and the flexible lead. The wires are joined and silver-brazed through the central opening of the connector after any excess wire has been clipped

off. Then, a suitable moistureproof, electrical insulating potting compound is worked into the central opening to encapsulate the wire junctions.

### NOTES:

1. A particular advantage of this development is that, where temperature conditions permit, only a limited amount of expensive metal-sheathed thermocouple wire need be used. Less expensive wire is used from the connectors to the recording instruments.
2. This method should be useful for making electrical connections that will be subjected to severe mechanical and chemical conditions. It has the further advantage of making it possible to readily inspect the work at all stages.

**SOURCE:** Langley Research Center (Langley-26)

### HYDRAULIC-PRESS INTENSIFIER

**THE PROBLEM:** To obtain high pressures without the use of high pressure presses.

#### SOLUTION

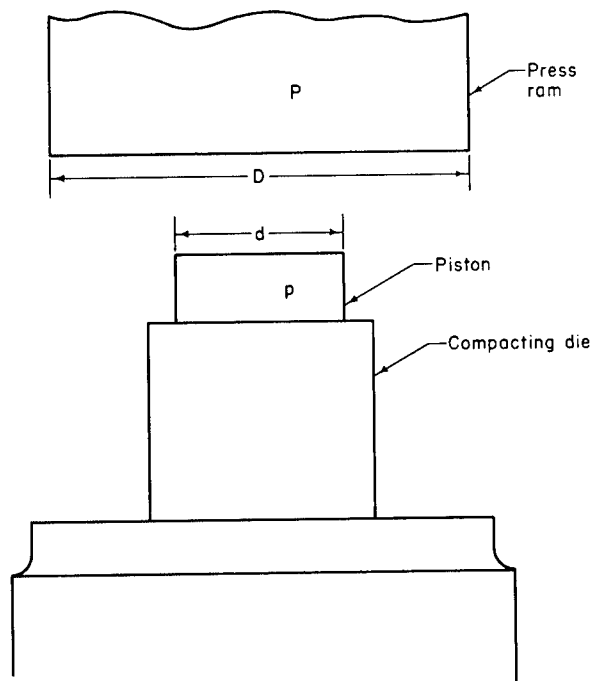

By using the principle that pressures are inversely proportional to the areas (also the diameters squared), a low-capacity press can develop extremely high pressures by the action of a large diameter press ram against an auxiliary small diameter piston or work ram.

An "intensifier" can be mounted on the ram of a low pressure hydraulic press. This device consists of two hollow steel cylinders, shrunk together to achieve a high strength assembly with a 6-inch inside diameter and a 28-inch outside diameter. The 6-inch cavity is filled with liquid, and a powdered metal preform is placed therein. The assembly is then driven by the ram upwards against a matching 6-inch fixed piston. A pressure in the order of 100,000 psi uniformly compacts the preform.

*NOTE:* Pressures which can be achieved by this technique are limited only by the ultimate mechanical strength of the "container" and piston.

*SOURCE:* Lewis Research Center (Lewis-118)

### HIGH-VACUUM VALVE STEM MODIFICATION

**THE PROBLEM:** To prevent leakage in vacuum valves which develops at the valve seat because of galling between the valve stem and the valve seat.

#### SOLUTION

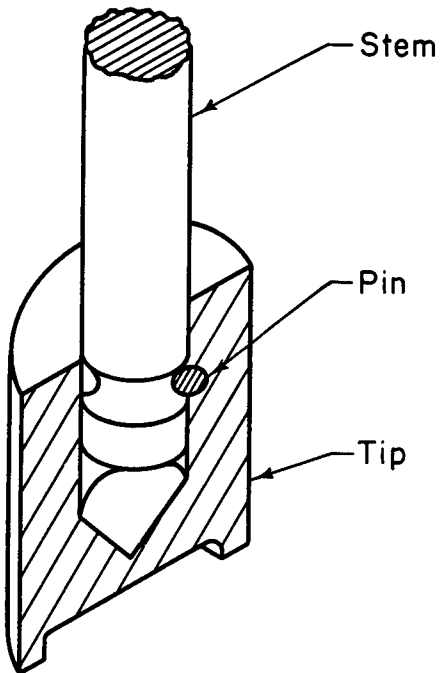

Modify the valve stem so that no motion develops between the valve seat and the end of the valve stem. Dimensions can be determined from the particular valve being modified. A two-piece valve stem is made as shown in the above illustration. A groove is cut in the stem to receive the pin. This pin also goes through the head to hold the tip or head to the stem, and at the same time enables the stem to rotate, while the head remains stationary on the valve seat. Incorporating this modification prevents the galling condition.

*SOURCE:* Lewis Research Center (Lewis-197)

**SECTION 10**

**HOISTING**

	<i>Page</i>
BUCKLE TO JOIN WEB STRAPS QUICKLY, ADJUST EASILY..	101
A SELF-BALANCING LOADING BEAM.....	102
(O. H. Edwards) *	

---

\* Innovator).

## BUCKLE TO JOIN WEB STRAPS QUICKLY, ADJUST EASILY

**THE PROBLEM:** To develop a means for joining web straps quickly and one that will allow easy adjustment to simplify hoisting operations.

### SOLUTION

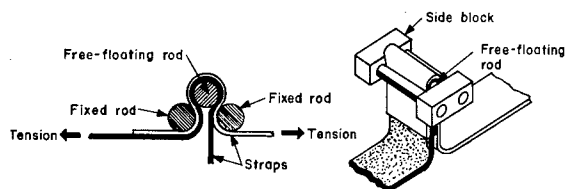

A buckle that permits two straps to be quickly jointed, then held by the combined forces of strap load tension and friction can simplify hoisting operations. It is a simple device consisting of three rods, two of which are attached to side blocks approximately forming a block **O**, and the other free and shorter than the other two.

The first step in joining two straps is to lay out the ends so that they overlap by at least 18 inches. Then, the overlapped portion of the strapping is folded up at the mid-point and the **O**-shaped device is slid down over the folded portion. A short rod is then inserted into the folded strapping so that both straps go around the outer surface of the short rod. This rod is

free floating and short enough to pass between the side blocks.

When the straps are adjusted, tension is exerted on both straps. This pulls the free floating rod down so that straps contact the two fixed rods. As long as the straps are under tension, clamping pressure will be exerted by the rods on the straps. This clamping pressure develops a static frictional force between the two straps. The frictional force will always be greater than the tension on the strap.

Although designed for web straps, this buckle is also suitable for other flexible strapping, including leather or plastic, provided they are used under tension.

*NOTE:* This innovation was intended for hoisting large irregular shapes, such as rocket motors, but it would be suitable for many loads encountered in warehouse operations or longshore hoisting.

*SOURCE:* Chance Vaught Corporation, Langley Research Center (Langley-21)

## A SELF-BALANCING LOADING BEAM

**THE PROBLEM:** To move heavy machine apparatus or other loads when they are under an overhang which prevents a crane from being used directly.

### SOLUTION

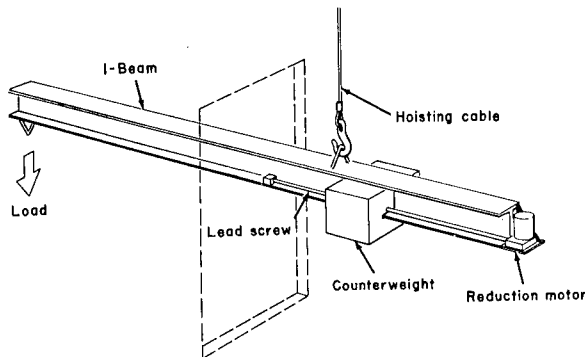

A motor driven self-balancing loading beam can be used for hoisting obstructed loads. An I-beam and a counterweight are selected to suit the size and weight of the load to be handled. A hoisting eye is mounted just enough off the center of the I-beam to allow the counterweight to balance the load. A load is placed at one end of the beam; at the other end a motor is placed which is geared to drive a lead screw. Turning the lead screw moves the counterweight along the beam.

In using the balancing beam, only two steps are required: (1) the load is secured to the beam and (2) the counterweight is moved along the beam until the exact balance point is found.

The load may then be guided into place. (Only one man was required to guide a 1,500-pound load in the application at MSFC.)

Overloading is impossible because the counterweight chosen will balance only a given weight. This gives the loading beam an automatic safety factor.

#### NOTES:

1. Use of this beam can greatly simplify many types of load moving jobs, in manufacturing and storage operations, in shops where heavy components must be handled in a limited space, or when the hoisting cable cannot be directly attached to the load.
2. Safety alone would justify the use of this balancing beam in many load handling operations. Not only is overloading prevented, but a vertical lift operation can be made, whereas a standard hoisting cable could not hold the load until it was clear of all obstruction.
3. By the proper selection of I-beam and counterweight, loads of almost any size and weight can be handled with this device.

*SOURCE:* George C. Marshall Space Flight Center (M-FS-84)

*"The aeronautical and space activities of the United States shall be conducted so as to contribute . . . to the expansion of human knowledge of phenomena in the atmosphere and space. The Administration shall provide for the widest practicable and appropriate dissemination of information concerning its activities and the results thereof."*

—NATIONAL AERONAUTICS AND SPACE ACT OF 1958

## NASA TECHNOLOGY UTILIZATION PUBLICATIONS

These describe science or technology derived from NASA's activities that may be of particular interest in commercial and other nonaerospace applications. Publications include:

**TECH BRIEFS:** Single-page descriptions of individual innovations, devices, methods, or concepts.

**TECHNOLOGY SURVEYS:** Selected surveys of NASA contributions to entire areas of technology.

**OTHER TU PUBLICATIONS:** These include handbooks, reports, notes, conference proceedings, special studies, and selected bibliographies.

*Details on the availability of these publications may be obtained from:*

National Aeronautics and Space Administration  
Code ATU  
Washington, D.C. 20546

Technology Utilization publications are part of NASA's formal series of scientific and technical publications. Others include Technical Reports, Technical Notes, Technical Memorandums, Contractor Reports, Technical Translations, and Special Publications.

*Details on their availability may be obtained from:*

National Aeronautics and Space Administration  
Code ATS  
Washington, D.C. 20546

NATIONAL AERONAUTICS AND SPACE ADMINISTRATION  
Washington, D.C. 20546