

NASA (7) CONTRACTOR
REPORT

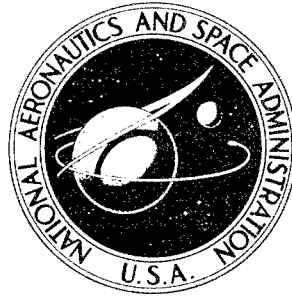

8
NASA CR-515

B065003

NASA CR-515

AMPTIAC

DISTRIBUTION STATEMENT A
Approved for Public Release
Distribution Unlimited

INDUCTION PROCESSED SEPARABLE TUBULAR BRAZED CONNECTORS

by V. Hunt

Prepared by
AEROJET-GENERAL CORPORATION
Sacramento, Calif.
for Lewis Research Center

20020326 090

NATIONAL AERONAUTICS AND SPACE ADMINISTRATION • WASHINGTON, D. C. • ⁽¹⁰⁾ JULY 1966

(INDUCTION PROCESSED SEPARABLE TUBULAR BRAZED CONNECTORS)

By V. ^①Hunt

Distribution of this report is provided in the interest of information exchange. Responsibility for the contents resides in the author or organization that prepared it.

**Reproduced From
Best Available Copy**

Prepared under Contract No. NAS 3-2555 by ¹³
5 AEROJET-GENERAL CORPORATION
6 Sacramento, Calif.

for Lewis Research Center

NATIONAL AERONAUTICS AND SPACE ADMINISTRATION ¹²

FOREWORD

The research described herein, which was conducted by Aerojet-General Corporation, Liquid Rocket Operations, was performed under NASA Contract NAS 3-2555 with Mr. J. M. Kazaroff, Chemical Rocket Division, NASA Lewis Research Center, as Technical Manager. The report was originally issued as Aerojet-General Report No. 8800-24, November 1965.

ABSTRACT

Wol
Methods for producing separable tube joints, other than mechanical, were investigated for application of these joints to the M-1 engine lines. The induction process was selected for brazing the separable tube connectors. Special plier-type induction brazing tools were made to permit the brazing of M-1 thrust chamber transition tube joints to the fuel torus. An 82% gold-18% nickel brazing alloy was used with a brazing temperature range of 1900°F to 1950°F. The tubes and sleeves in this application were of 0.032-in. wall AISI, Type 347 stainless steel. *Lead*

→
P17

TABLE OF CONTENTS

	<u>Page</u>
I. <u>SUMMARY</u>	1
II. <u>INTRODUCTION</u>	1
III. <u>TECHNICAL DISCUSSION</u>	2
A. SELECTION OF JOINING PROCESS	2
B. EQUIPMENT AND TOOLING	5
C. BRAZING QUALIFICATION TEST SPECIMENS	10
D. RE-BRAZING OF SLEEVE TUBE JOINTS	17
1. <u>Repair Method No. 1</u>	17
2. <u>Repair Method No. 2</u>	19
3. <u>Repair Method No. 3</u>	19
E. INSPECTION OF BRAZE JOINTS	19
1. <u>Visual Inspection</u>	19
2. <u>Radiographic Inspection</u>	19
F. TESTING OF BRAZED JOINTS	19
G. METALLOGRAPHIC EXAMINATION OF BRAZED JOINTS	24
IV. <u>CONCLUSIONS</u>	29
V. <u>RECOMMENDATIONS</u>	29

I. SUMMARY

The induction brazing process for joining separable tube connectors is discussed in this report. To obtain leak-tight joints on the M-1 engine special consideration was required because of the limited accessibility to tubular joints. The large size of the M-1 engine components, particularly the thrust chamber assembly, coupled with the required assembly sequence created the need for specialized joining techniques. Easy access for making repairs was also desirable.

The joining of closely spaced tubular joints, of the M-1 thrust chamber transition tubes to the fuel torus, was an initial requirement. Automated welding and various brazing processes were given major consideration. Equipment design complexity, process repeatability, nondestructive testing reliability, joint cleanliness, and economic considerations led to the selection of portable induction brazing as the most desirable method.

Special portable induction brazing tools were designed to permit accessibility between the closely spaced tubes. In addition to the plier-type split induction coil, the tools contained purge ports for protection against oxidation during the thermal cycle.

A number of tube joints, with sleeves that were pre-loaded with a 82% gold-18% nickel braze alloy, were brazed to qualify the specially-designed induction braze tool. The joints were successfully brazed and exceeded the mechanical properties of the 0.032-in. wall thickness, AISI Type 347, stainless steel tubes.

II. INTRODUCTION

Methods for producing separable tube joints, other than mechanical, were investigated for application of these joints to the M-1 engine lines. Several factors, such as accessibility to the external and internal joint areas, inspection criteria, reproducibility, and environmental conditions limited the selection of the joining method. Separable-type tube joints are highly desirable for joint areas exposed to high pressures and vibratory stresses at various temperatures during engine operation. The difficulty in making and maintaining leak-tight joints was the primary reason for eliminating mechanical connections. Weight was also a factor.

High quality automatic GTAW-welded lap joints can be produced providing that the clearance near the joints is sufficient to allow rotation of the welding head. The lap-type welded joint has several drawbacks; there is difficulty in separation and rewelding, as well as the possibility of entrapping contaminants in the lap interface area. Sleeve joints brazed by a patented exothermic process using silver braze alloy were evaluated on a limited basis; however, the possibility of flux entrapment on closure brazed tube joints made this method unacceptable. Separation of this type of brazed joint was not examined.

The induction process was selected for brazing of the separable tube connectors. The braze joints that were produced and tested were stronger than the parent metal tubing and were free from internal joint contamination. Special plier-type induction brazing tools were made to permit the brazing of M-1 thrust chamber transition tube joints to the fuel torus. An 82% gold-18% nickel brazing alloy was used with a brazing temperature range of 1900°F to 1950°F. The tubes and sleeves in this application were 0.032-in. wall AISI, Type 347 stainless steel.

III. TECHNICAL DISCUSSION

A. SELECTION OF THE JOINING PROCESS

Several processes for joining separable tube connectors were explored for use on the M-1 thrust chamber transition tubes-to-fuel torus joints. These included various mechanical-type joints, automatic fusion welding, and various brazing methods.

Mechanical-type joints were investigated but no testing was performed because the need for obtaining and maintaining leak-tight joints precluded the use of this method. Other disadvantages included the fitting of mechanical joints into a limited access area and the potential weight penalty.

Automatic GTAW-welded tube joints were examined. Sample weldments were made with full weld penetration of the joints and the weld quality was good. Mechanical testing resulted in failure of the tubes, usually in the weld-heat-affected zones. Fit-up and repair-replacement criteria dictated the need for a lap-type joint; however, disadvantages of this type of joint include the space requirements for the moving weld head and the potential entrapment of contaminants. Typical welded joints are shown in Figure 1.

Brazing of joints using a patented exothermic heating process was investigated. The sleeve fittings contained pre-places silver braze alloy and self-contained heating elements. To initiate the braze cycle, the tube ends were fluxed, inserted into the sleeve connector, then the heat cycle was initiated by an electrical charge to the starting leads connected to the heating element. The process produced sound braze joints; however, flux deposits, excessive discoloration in the joints, and the size of the heating element prevented its use for transition tube joints. A view of a completed braze joint is shown as Figure 2. Braze joints of this configuration were not tested because the process would not lend itself to the required application.

Induction brazed tube joints were also evaluated. Sleeve tube connectors of AISI, Type 347 stainless steel, containing pre-placed 82% gold-18% nickel braze alloy, were used on tubing of the same composition as the sleeves. Preliminary braze tests were conducted using the standard plier-type braze tools to evaluate the induction brazing process. The brazed joints were inspected, followed by hydrostatic and mechanical tests. The brazed joints were of high quality and exceeded the parent tube material in mechanical properties. Braze joint surfaces are clean and free of discoloration;

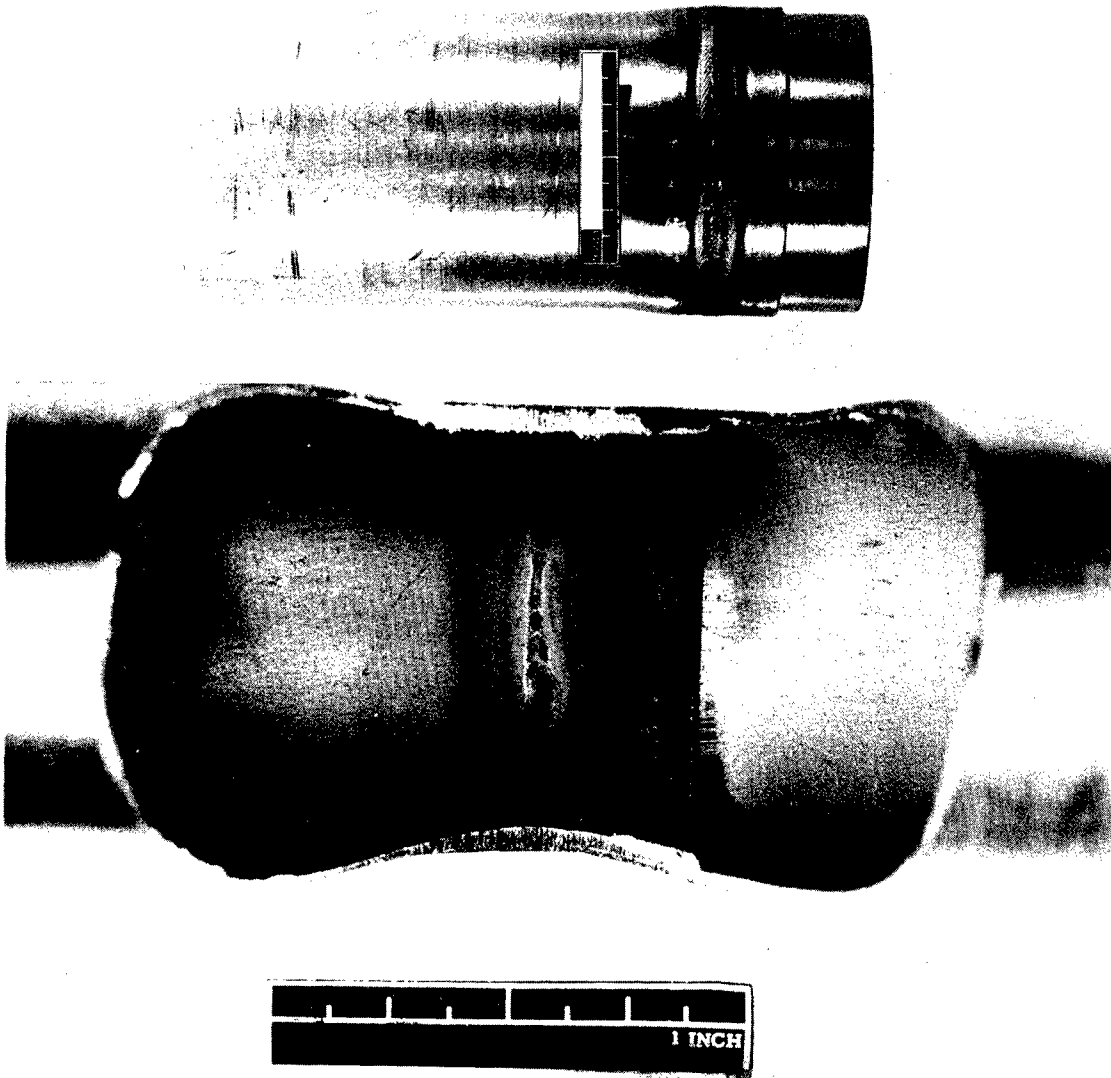

The top view is of an automatic TIG welded lap joint. Weld filler wire was not added. The lower view shows the internal surface of the welded lap joint. Slight surface discoloration is present in the weld heat affected zones.

FIGURE 1

Typical Welded Joints

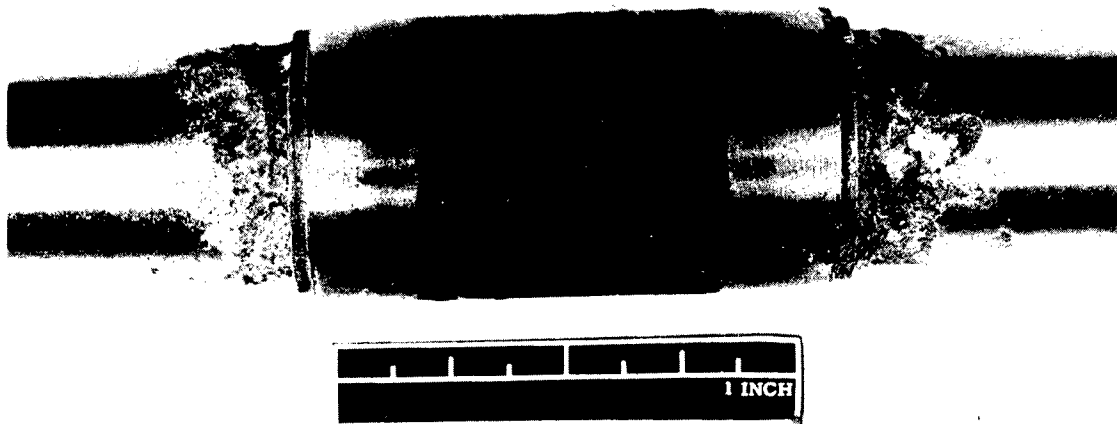

A view of an exothermic brazed sleeve-type tube connector joint made by a patented process. Flux deposits exist on the tube surface at the ends of the sleeve and a dark carbonaceous deposit on surface of the sleeve. Internal examination of the joint revealed flux deposits and discoloration of the tubes at the joint. The joint was brazed, using pre-placed 45% Silver alloy, having a flow point of 1145°F.

FIGURE 2

Completed Braze Joint

therefore they do not require internal flushing prior to engine operation. Uniform braze fillets were formed at the internal tube ends, preventing entrapment of foreign elements in the joints.

Repairs were made by sectioning the sleeve with a cut-off tool. The sleeve ends were stripped from the tube ends using an induction heating plier-type tool and a sleeve stripping tool. The deposited braze alloy was removed with a cleaning tool, then the tube ends were re-brazed in the same manner as in the initial braze operation. The re-brazed joints were equal in quality to the joints initially brazed (i.e., joints exposed to only one brazing cycle). The success of the re-braze tests proved this process to be a feasible method for making separable connections.

Because of space limitation between the torus-to-chamber transition tubes, the standard plier-type braze tool could not be used. A special plier-type braze tool containing recessed areas was designed and fabricated by the Aeroquip Corporation, Jackson, Michigan. A series of braze joint tests were conducted to determine the feasibility of utilizing the induction brazing process for the M-1 torus-to-chamber transition tubes prior to procuring the capital equipment required for this process.

B. EQUIPMENT AND TOOLING

The voltage regulator and the 25 KW radio frequency induction heating generator installation are shown in Figure 3. The automatic voltage regulator is for 440 volts, 3 phase, 60 cycle line current and 100 amperes capacity. The output or secondary voltage remains constant within $\pm 1\%$ for input or primary voltage variations between 440 to 520 volts. The secondary voltage may be set for any value ranging from 440 to 480 volts. The front view of the remote control console and pendant control station is shown in Figure 4. All brazing variables are set and controlled at the control console, which is remotely located and is connected to the generator by 150 ft of radio frequency power cable and water lines. The control pendant is connected to the control console by a 25 ft cable. Once a brazing cycle is established, it can be repeated by starting the cycle using the pendant start button.

The special plier-type braze tools (see Figure 5) were designed with reliefs, indicated by arrows, to permit access in joint-restricted areas between the tubes and the M-1 thrust chamber-to-torus transition joints. One tool has a swivel attached, which allows the tool to move 90 degrees to aid in aligning the tool with the joints. A braze tool is opened by moving the white lever toward the swivel, which releases the lock. Electrical power, water, and inert gas are carried to the braze tools through the tubes extending from the connection end of the tools. These braze tools are capable of producing uniform heat patterns at the joints to maintain uniform brazing alloy flow within the braze joint.

A special variable speed power-driven cleaning tool is shown in Figure 6. This tool is used to clean and deburr the tube ends. A vacuum line can be attached to the hose fitting to prevent foreign particles from entering into the lines and contaminating the joint during the deburring operation.



FIGURE 3
Induction Brazing Generator

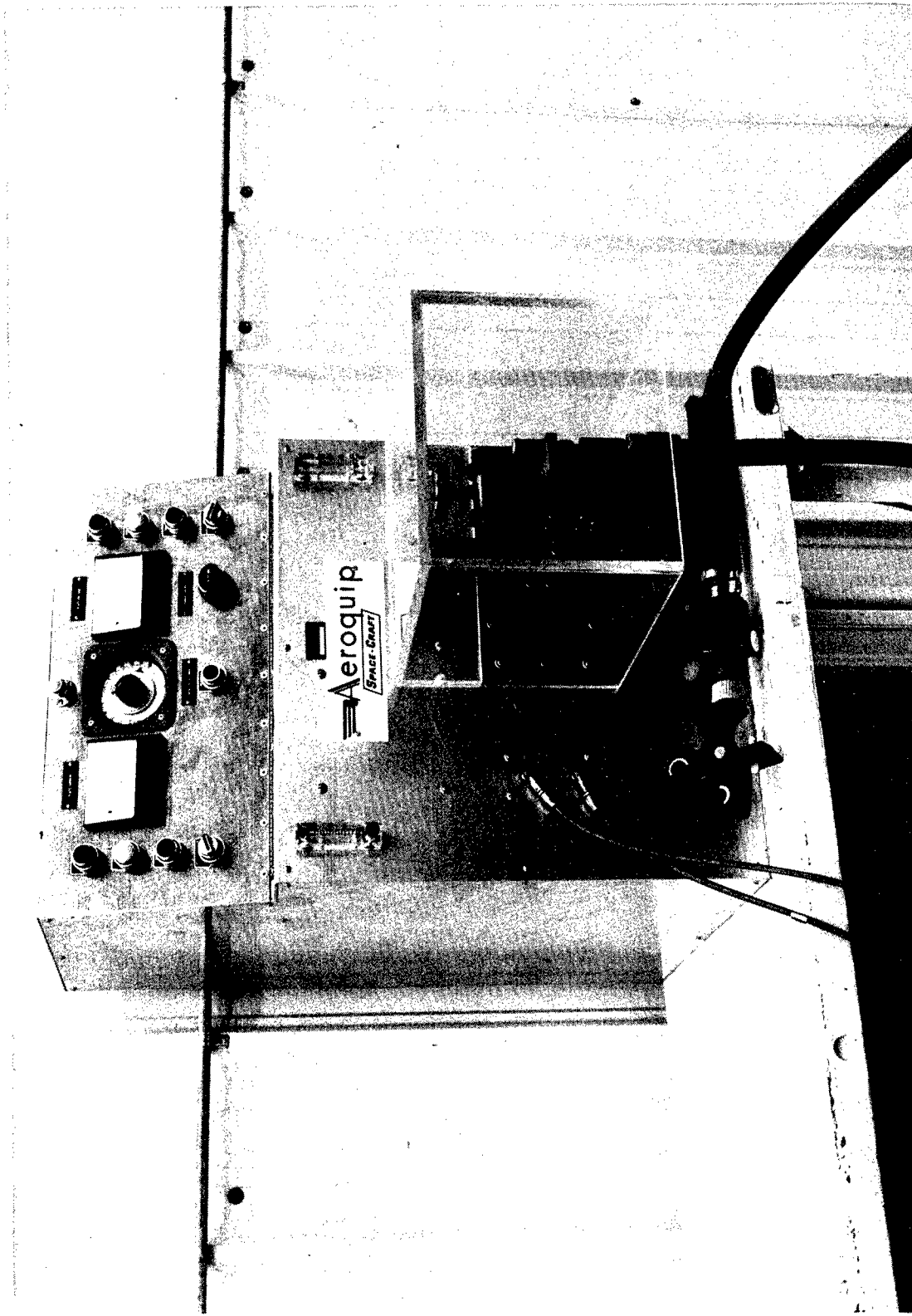

FIGURE 4
Braze Control Console

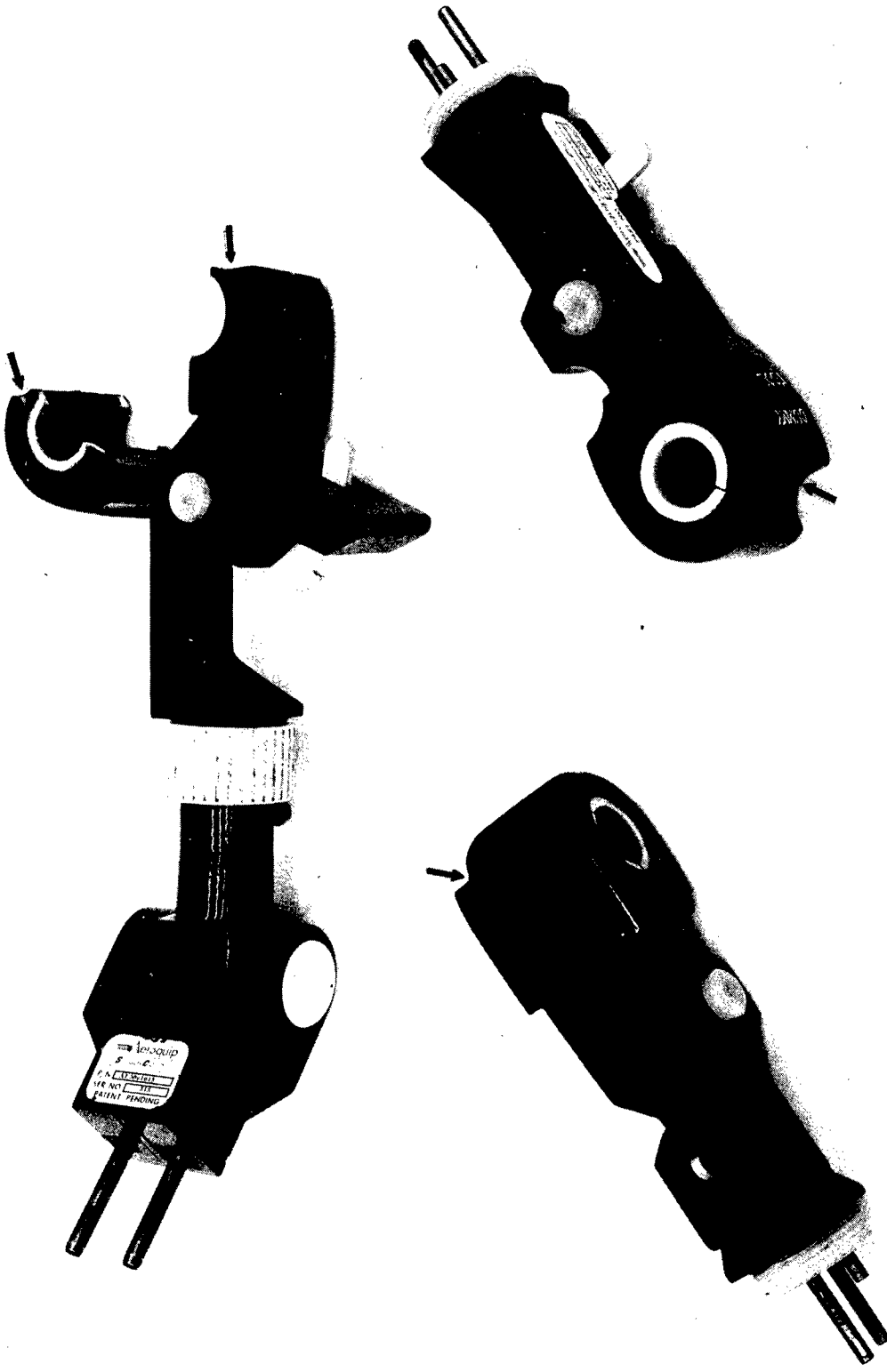

FIGURE 5
Special Braze Tool

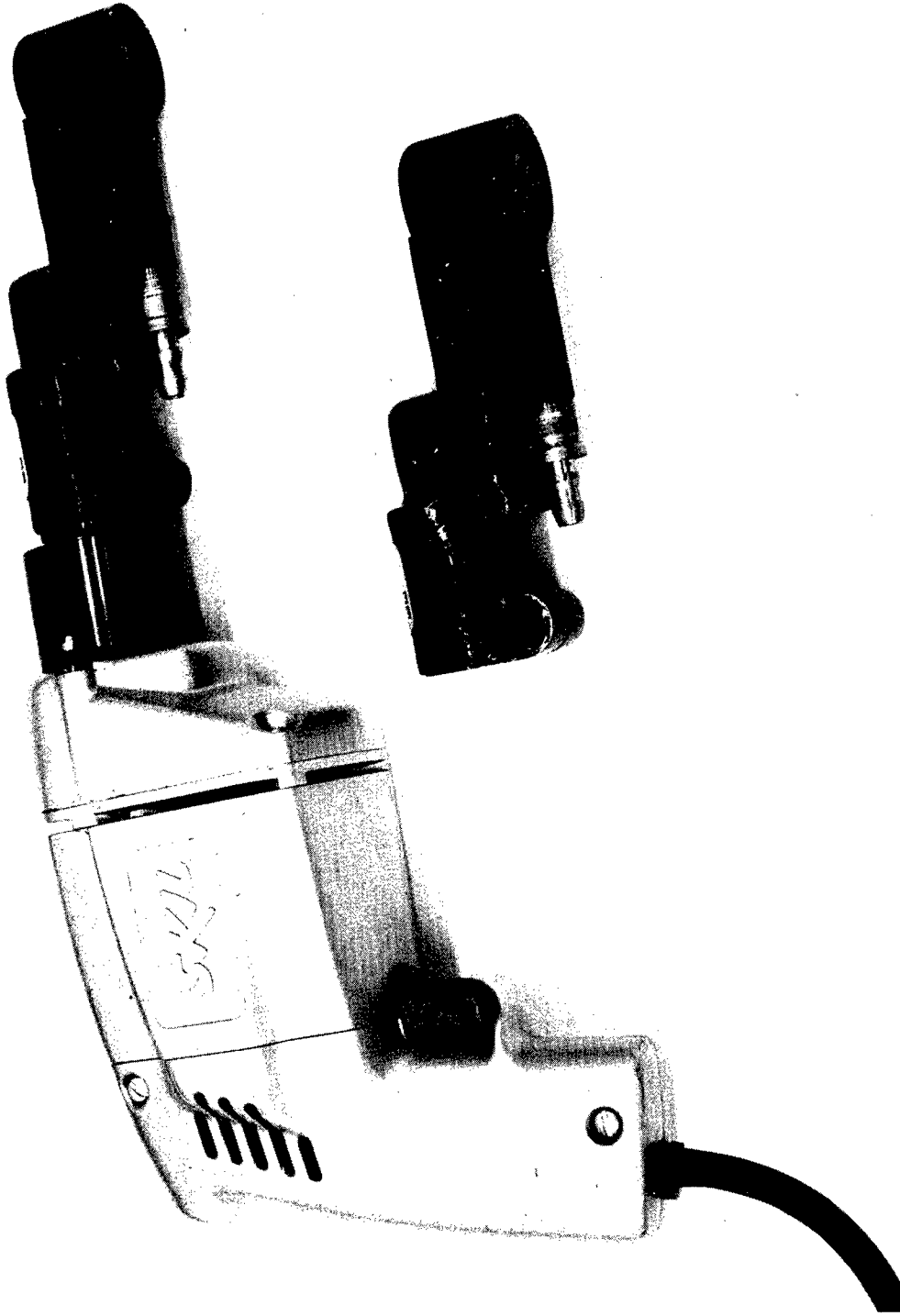

FIGURE 6
Special Debur Tool

The manually operated cut-off tool (see Figure 7) contains four cutting wheels that can be used to part the joint by manually rotating the tool 90 to 95 degrees around the joint and progressively turning the knurled screw to the right. Also shown in Figure 7 is a brazed sleeve tube joint and a similar joint parted at the sleeve by the cut-off tool.

The upper view in Figure 8 shows a brazed sleeve fitting, as parted by the cut-off tool; the expandable sleeve stripping tool; and the induction heating de-braze tool. The lower view is of the expandable stripping tool and sleeve joint positioned in the de-braze induction heating tool. This induction heating de-braze tool contains one induction heating coil to confine the heating zone to a narrow band on the sleeve. (The braze tool contains two induction heating coils allowing both sleeve ends to be brazed simultaneously.) Removal of the sleeve joint is accomplished by assembly of the tools, as shown in the lower view of Figure 8, then applying heat to the braze joint until the braze alloy becomes semi-molten. The de-braze tool is then pressed against the expandable stripping tool and the sleeve is removed from the tube end.

Two views of the multiple tube holding fixture used to qualify the special braze plier-type tools is shown in Figure 9. Accessibility to the joints with the braze tool simulates the condition of the M-1 thrust chamber-to-torus transition joint, including the tube spacing and the clearance between the tubes and thrust chamber. The tubes are located in pairs on 1.134-in. centers. The spacing between the pairs is 1.71-in. on centers and the outside tube diameter is 0.760-in.

A sketch of the special design brazing tool is shown in Figure 10, which also illustrates the relative positions of the tubes. The design clearly shows how accessibility was obtained.

A single tube joint fixtured in the vertical plane is shown in Figure 11. This set-up was used to establish the process variables required to produce satisfactory brazed joints. The established brazing cycle was used to qualify the special plier-type braze tool with the tubes fixtured in the previously described multiple tube holding fixture.

A brazed tube joint connected for hydrostatic testing is shown in Figure 12. The testing cycle for 10 brazed tube joints was 2350 psi for five minutes. The pressure was then gradually increased until failure occurred. All failures were to the tube parent material in the range of 7800 to 8000 psi.

C. BRAZING QUALIFICATION TEST SPECIMENS

A preliminary brazing cycle was established for single tube joints fixtured in the vertical plane as previously described. The established cycle is delineated below.

1. Argon-purge the tube joint internal area for two minutes at 15 CFH.

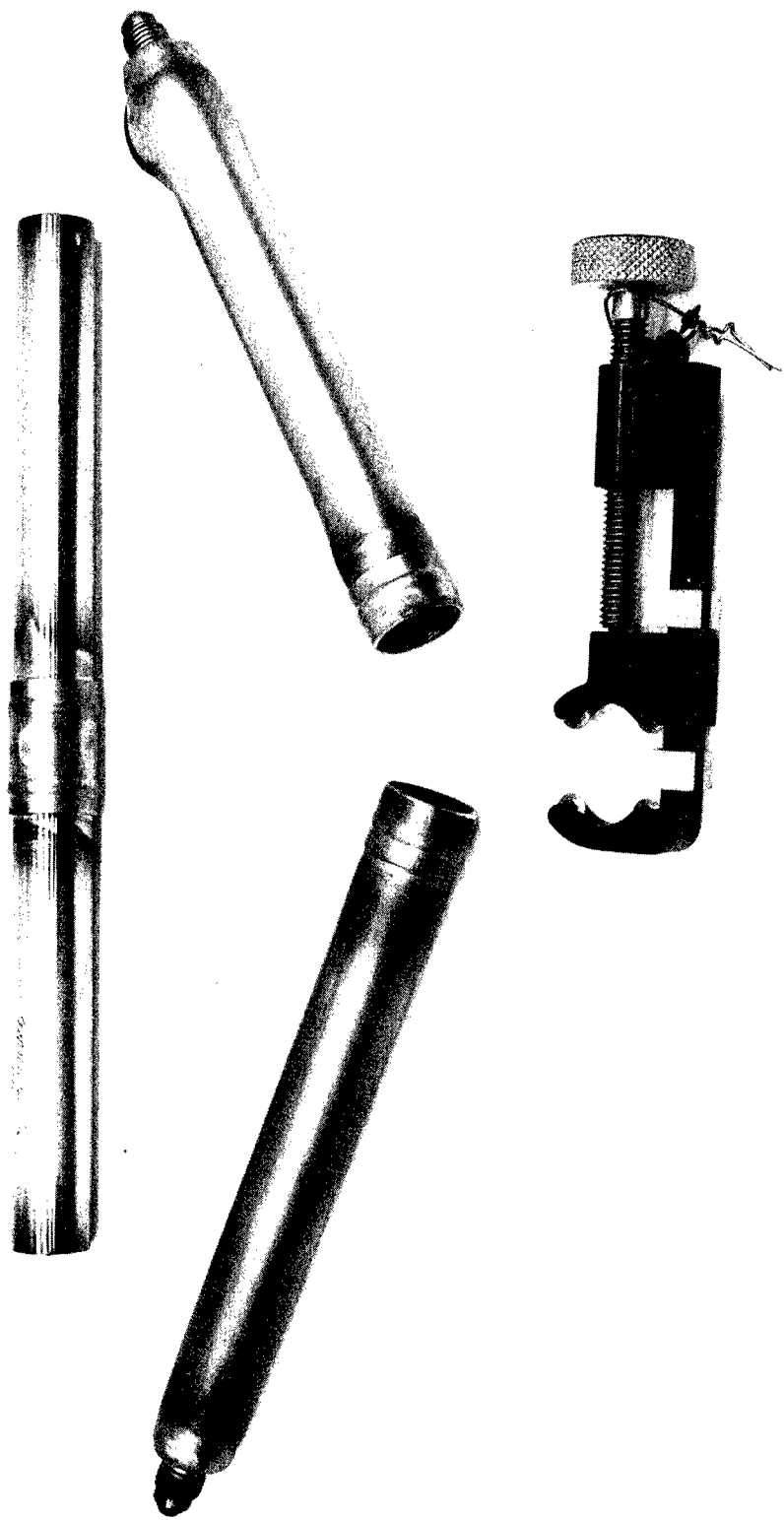
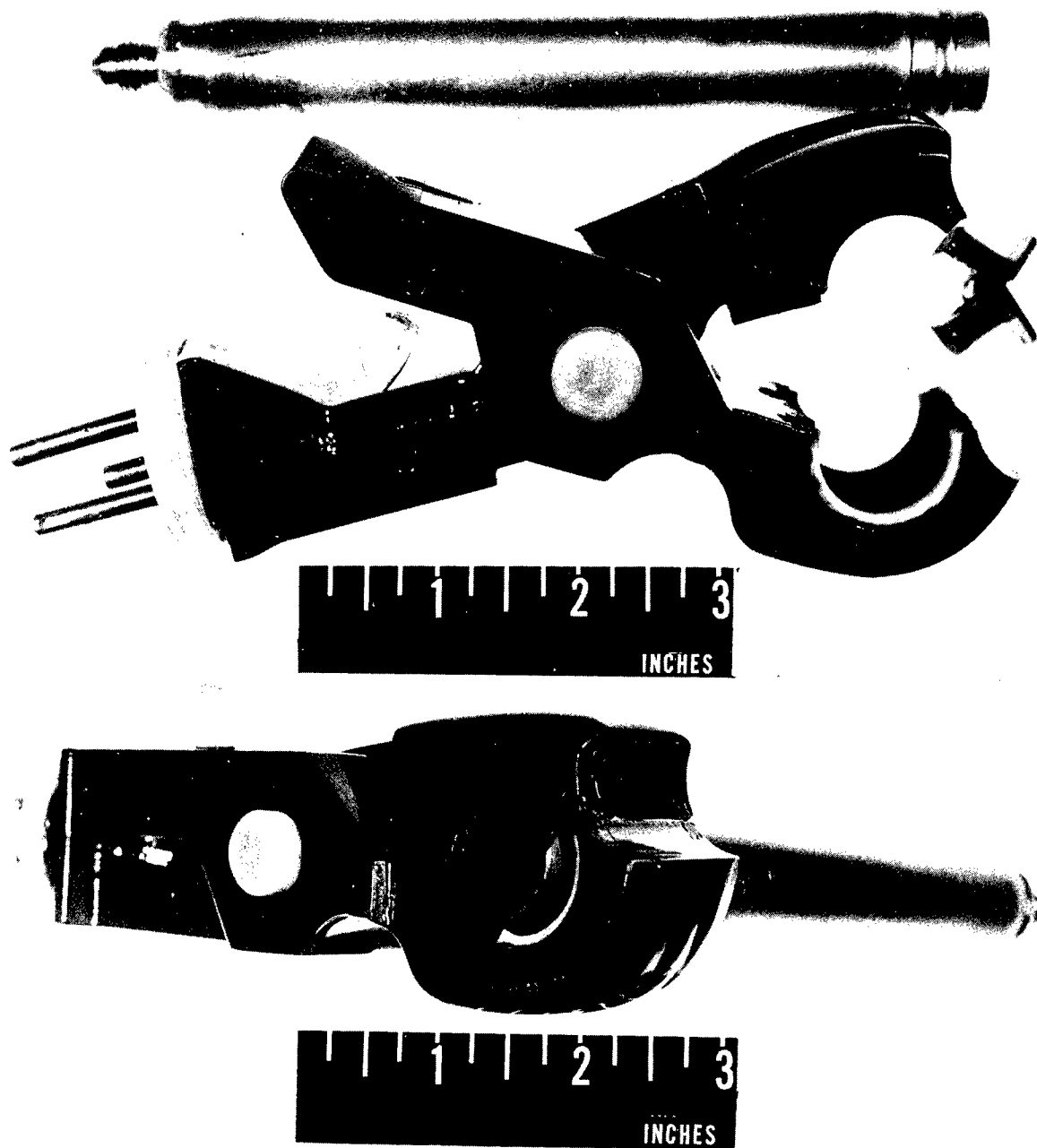

FIGURE 7
Special Cut-Off Tool



The upper view shows a brazed sleeve as sectioned by the parting tool, the induction de-braze tool and the sleeve stripping tool.

The lower view shows the sleeve stripping tool positioned in the de-braze tool ready for removal of the sleeve.

FIGURE 8

Brazed Sleeve (Top View)
and Stripping Tool (Bottom View)

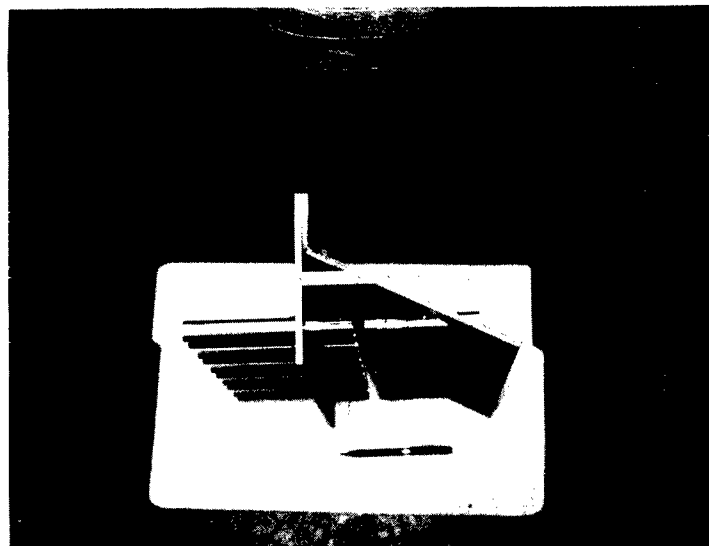

An end view of the tube-locating fixture which was used to qualify the special plier type brazing tools. The braze tool access area simulated the M-1 torus to thrust chamber area.



A front view of the tube locating fixture holding the tube spacing the same as on the M-1 torus to thrust chamber transition joints prior to brazing.

FIGURE 9

Multiple Tube Holding Fixture

0.032 in. wall 0.760 in. dia transition tubes

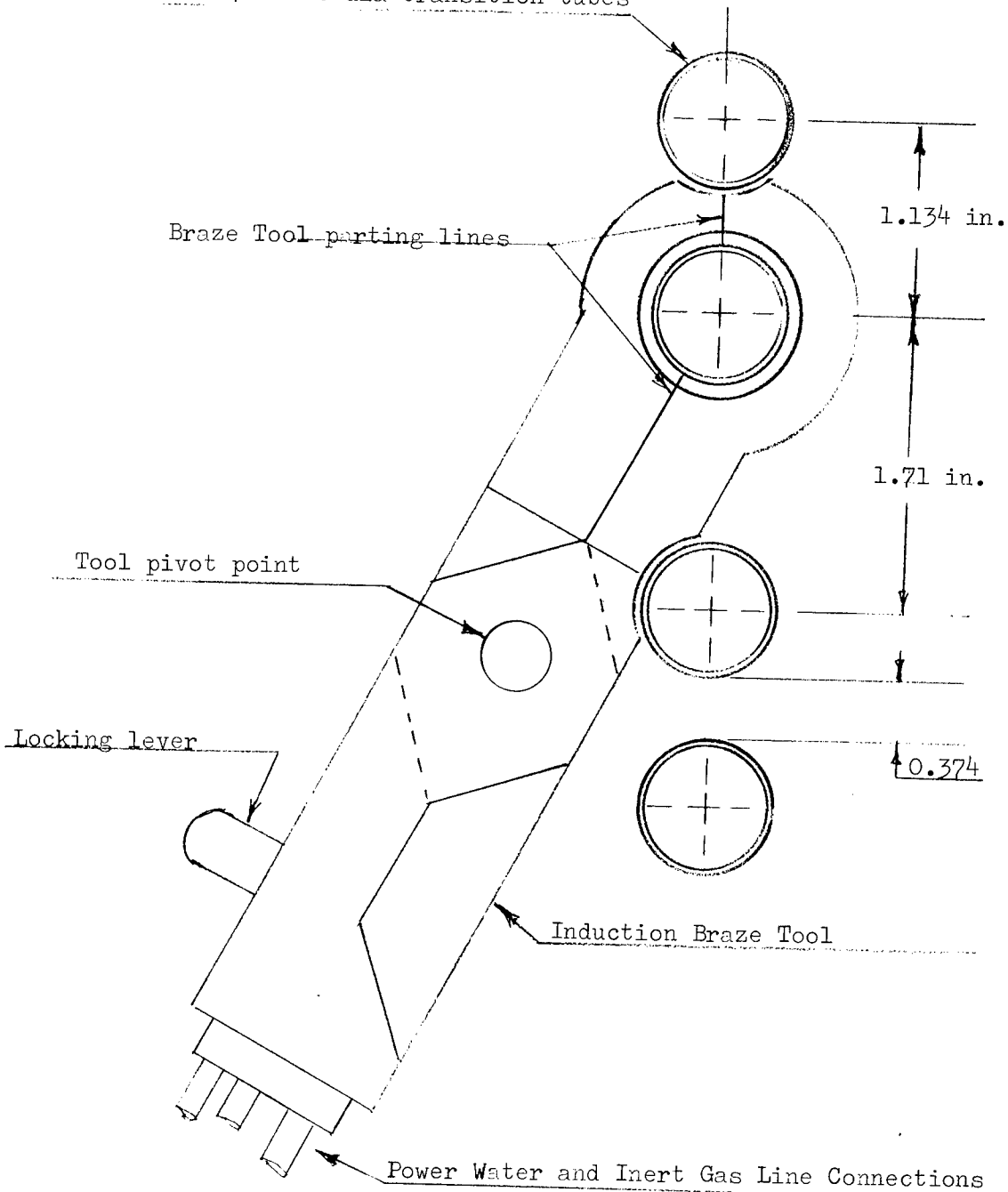

Sectional view of transition tubes showing special braze tool design to provide accessibility.

FIGURE 10

Sectional View of Transition Tubes

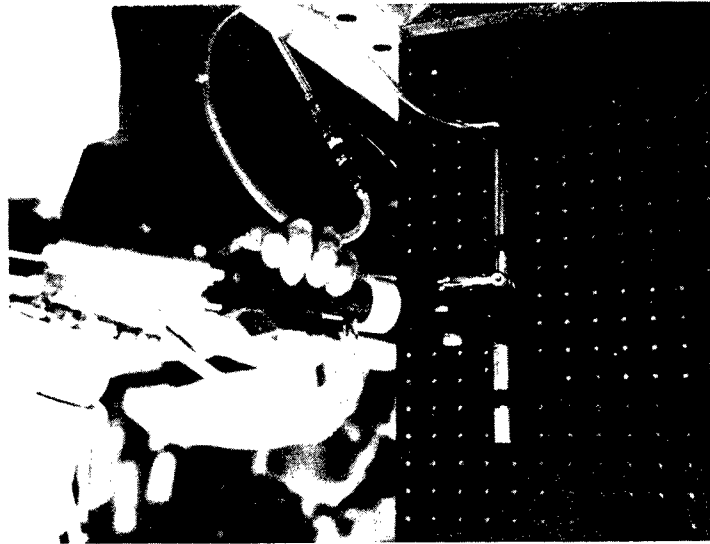

A single tube joint fixtured in the vertical position. This set-up was used to develop the brazing cycle to qualify the special braze tool. Also shown are argon gas purge lines to the braze tool and lower end of the joint. The clamp below the tool was used to prevent mislocation of the braze tool.

FIGURE 11

Single Tube Joint
Fixtured in Vertical Plane



This view shows a brazed tube fixtured for hydrostatic testing. The hydrostatic test cycle used was 2350 psi for five minutes then pressure increased until failure occurred. There was no leakage of the brazed joint. All failures occurred in the tubes in the range of 7800 to 8000 psi.

FIGURE 12

Brazed Tube Joint
Connected for Hydrostatic Testing

2. Argon-purge the brazing tool (located around the joint) for 30 sec.
3. Braze at 1900 to 1950°F for 25 sec. This brazing temperature was determined by using four thermocouples attached to the inside diameter of the joints.
4. Post-purge for two minutes to allow the brazed joint to cool sufficiently to prevent surface oxidation.

After several joints were brazed using the established procedure to verify the repeatability of the brazing cycle, the tube joints were then brazed in the multiple tube holding fixture as shown in Figure 13. The tube ends were cleaned with silicon carbide paper and then cleaned with acetone prior to assembly. Sleeve couplings and tube joints were handled with white lint-free gloves to prevent surface contamination of the parts. The tube joints were brazed in random sequence to determine the effects of heat conduction for the brazing tool upon the unbrazed joints. The maximum temperature during the heating of the unbrazed adjacent tube joints during the brazing cycle did not exceed 200°F. Contamination from oxidation on the adjacent unbrazed joints did not occur.

Joint variables were investigated during the brazing of the tubes in the multiple holding fixture. Some tubes were inserted into the sleeves the recommended minimum distance while others were inserted in the maximum distance. Several joints were pre-stressed to simulate misalignment conditions, which caused zero clearance in some areas of the joint. The remaining tube joints were brazed in the free state (unrestrained). The joints were shrouded in an argon atmosphere during the brazing cycle and until the joint had sufficiently cooled to prevent oxidation after the braze cycle was completed. All brazed joints revealed braze fillets at the ends of the sleeves except one joint in an area approximately 1/8-in. long. All joints contained uniform braze fillets at the tube ends in the sleeve. This was verified by visual inspection with a borescope.

D. RE-BRAZING OF SLEEVE TUBE JOINTS

When no visual evidence of braze alloy exists at the sleeve ends and radiographic inspection shows large internal voids present in the sleeve-to-tube contact areas, various repair procedures may be used to produce an acceptable joint.

1. Repair Method No. 1

This procedure involves cleaning the area to be repaired with acetone, then re-brazing the joint using the same braze cycle as for the initial braze. When the joint is rejected for lack of braze at one end, the braze sleeve stripping tool is used. This heating tool contains one heating coil and will confine the heat zone to one end of the sleeve. When both ends require repairs, the regular braze tool is used.

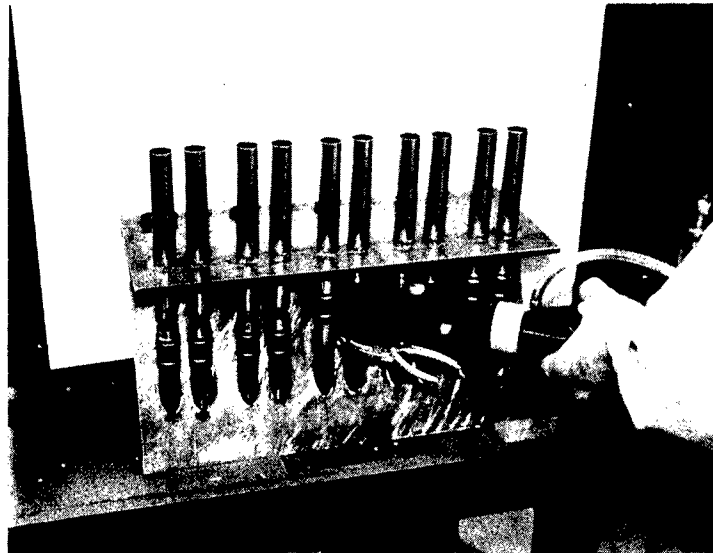

The above photograph shows the brazing tool in place and brazing the joint. The joint to the left of the tool has been brazed.

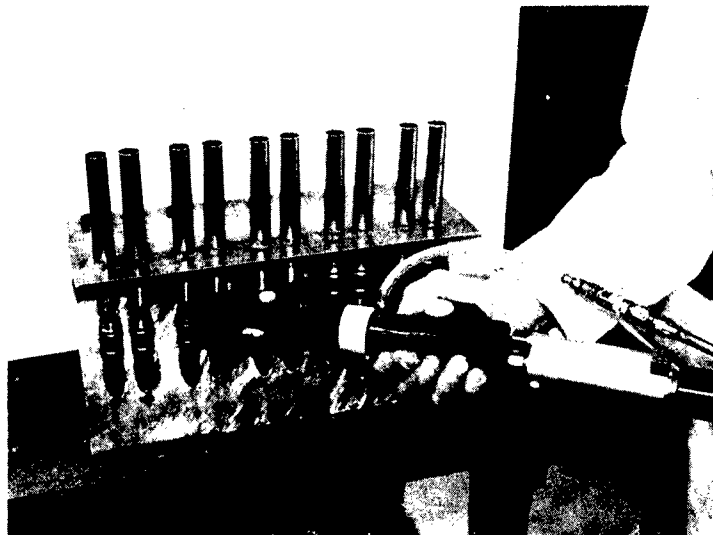

The above photograph shows the brazing of a joint with the joint to the left of the brazing tool unbrazed.

FIGURE 13

Brazing in Multiple Fixture

2. Repair Method No. 2

This method is used when one loose tube end results after the sleeve is cut. The sleeve is parted using the tool shown in Figure 7. Then, the sleeve ends are removed using the stripping tools shown in Figure 8.

The tube ends are cleaned, using the tool shown in Figure 6, to remove old braze deposits or other possible contaminants. The joint is then wiped clean with acetone and a new sleeve is used to repair the joint. The established braze cycle is used during this operation.

3. Repair Method No. 3

This method is used when both the tube members are permanently connected at one end, such as the M-1 thrust chamber-to-torus transition tubes. A step-by-step repair procedure is explained in Figure 14. To braze the male-female fitting to the tube, the single coil stripping tool is used. Then the regular braze tool is applied to braze the standard sleeve joint.

E. INSPECTION OF BRAZE JOINTS

1. Visual Inspection

A visual inspection was made of all brazed joints, using 10 power magnification for external defects. One joint contained an area approximately 1/8-in. long that did not show evidence of a braze fillet at one sleeve end. After this joint was tested, it was sectioned through the area that had no braze fillet. Examination under higher magnification showed the braze alloy had flowed to the sleeve end. This is shown by the upper right arrow in the lower view of Figure 15. A borescope was used to make a visual internal inspection of all brazed joints. All joints contained uniform braze fillets at the tube ends and there was no surface discoloration in the joint areas that had been heated during the brazing cycle.

2. Radiographic Inspection

All brazed joints were radiographically inspected. This inspection revealed minute voids in tube-to-sleeve contact lap areas of specimens 1, 3, 7, and 11, as indicated by the arrows in Figures 16 and 17. View 2 (V2) shows the same specimens as View 1 (V1) except that the specimens were rotated 90 degrees for full X-ray coverage. Voids appearing in the sleeve braze alloy reservoir are not considered defects and are not detrimental to the braze joints.

F. TESTING OF BRAZE JOINTS

Five brazed specimens were picked at random. They were hydrostatically proof-tested at 2350 psi for five minutes. The pressure was then slowly increased until failure occurred. No leakage existed at the proof pressure or prior to the tube failures.

A 1123
V

Condition

3.25

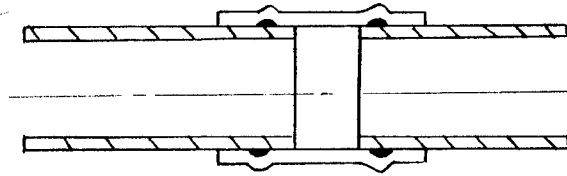

1. Original, Reheated, or Rejected Braze Joint.

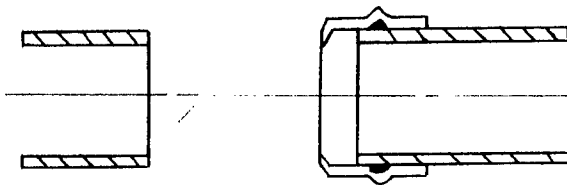

2. Removal of Original Union by Sectioning Fitting & Transition Tube.

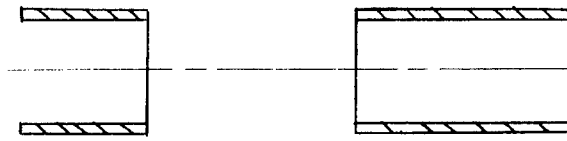

3. Removal of Fitting Stub by Debrazing Tools - Joint Prepared for Rebraze.

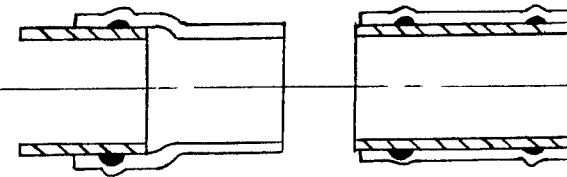

4. Male-female Fitting in Place.

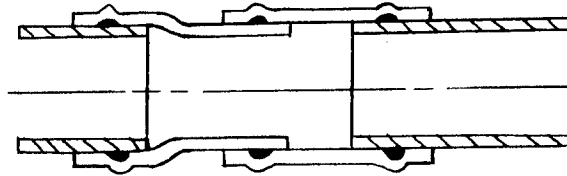

5. Completed Male-female Repair Joint.

FIGURE 14

Repair Method No. 3

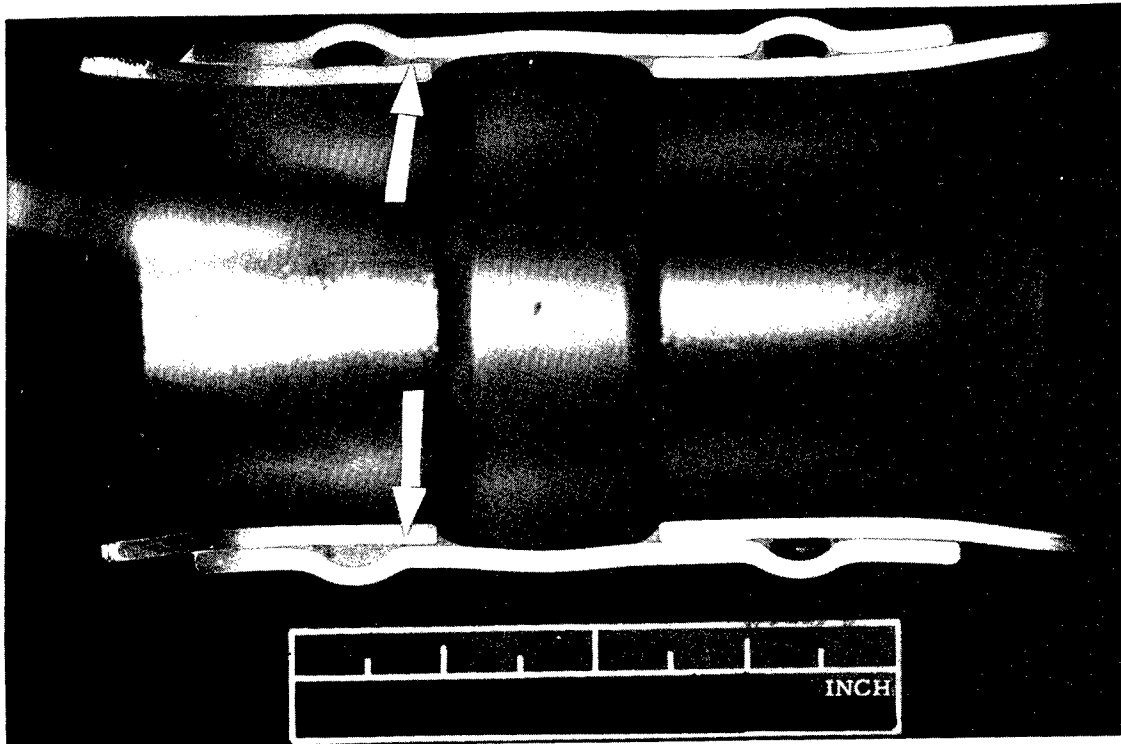

Cross-section view of brazed specimen No. 1. This specimen was brazed in the fixture with the joint in the free state with normal joint clearance and different tube insertion depths.

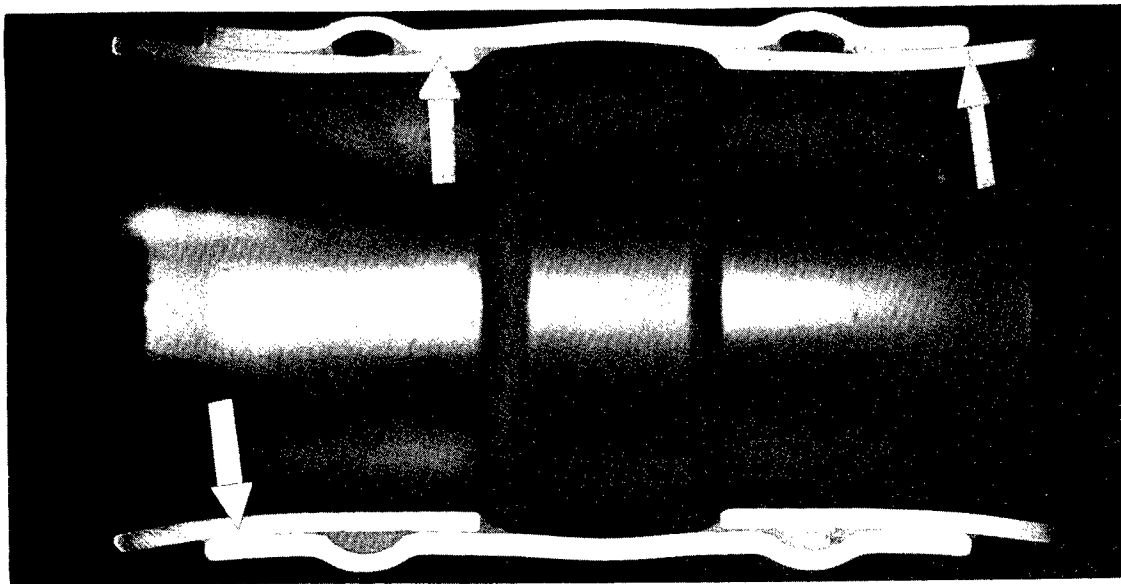

Cross-sectional view of specimen No. 3. This specimen was pre-stressed during the brazing cycle to produce zero clearances between mating members in the areas shown by the arrows.

FIGURE 15

Cross-Sections of Brazed Connector Joints

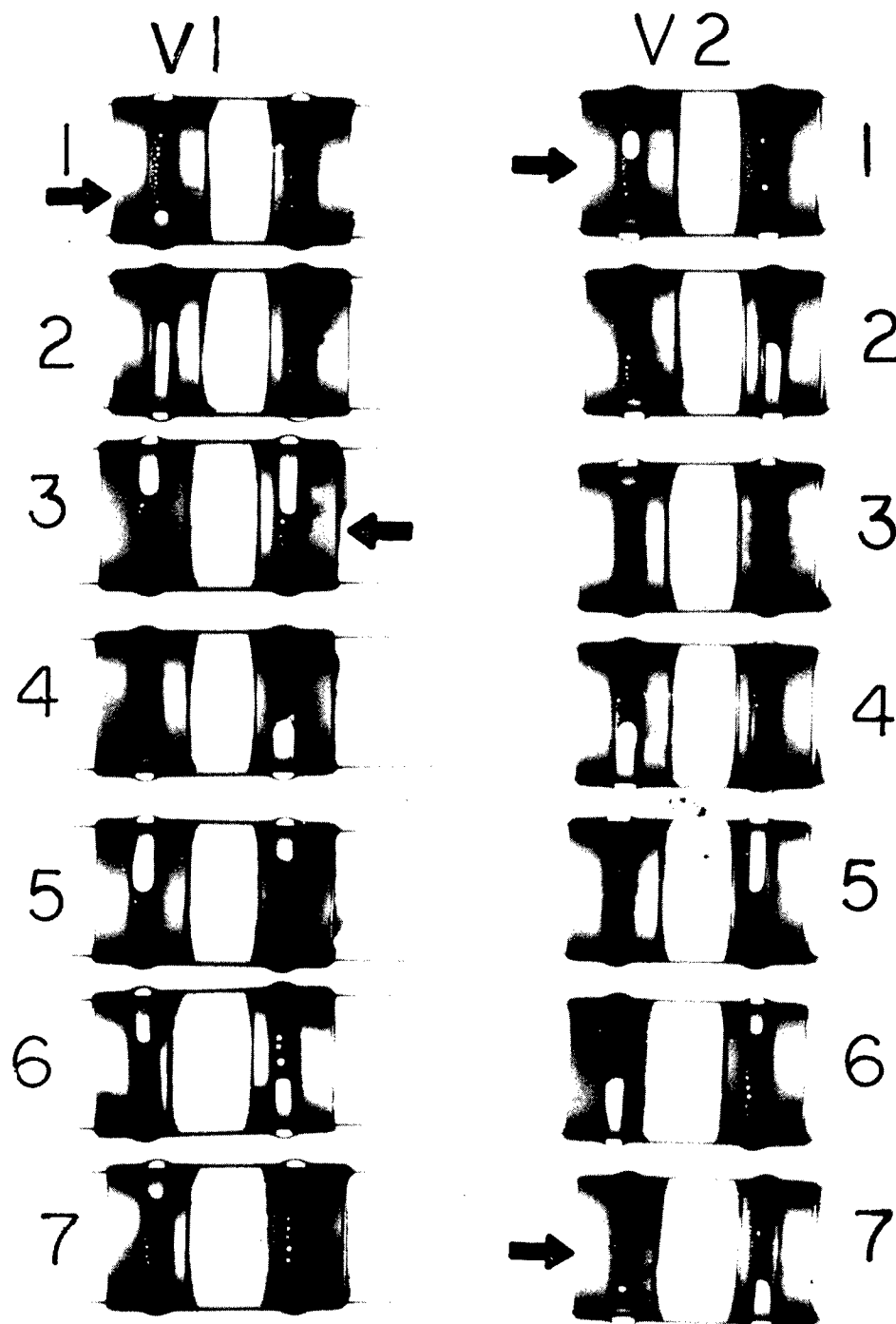

Radiographs taken of seven qualification brazed specimens. V2 shows the same specimens as V1 except the specimens were rotated 90°. Minute scattered porosity is evident in the braze joints shown by arrows.

FIGURE 16

Brazed Specimens

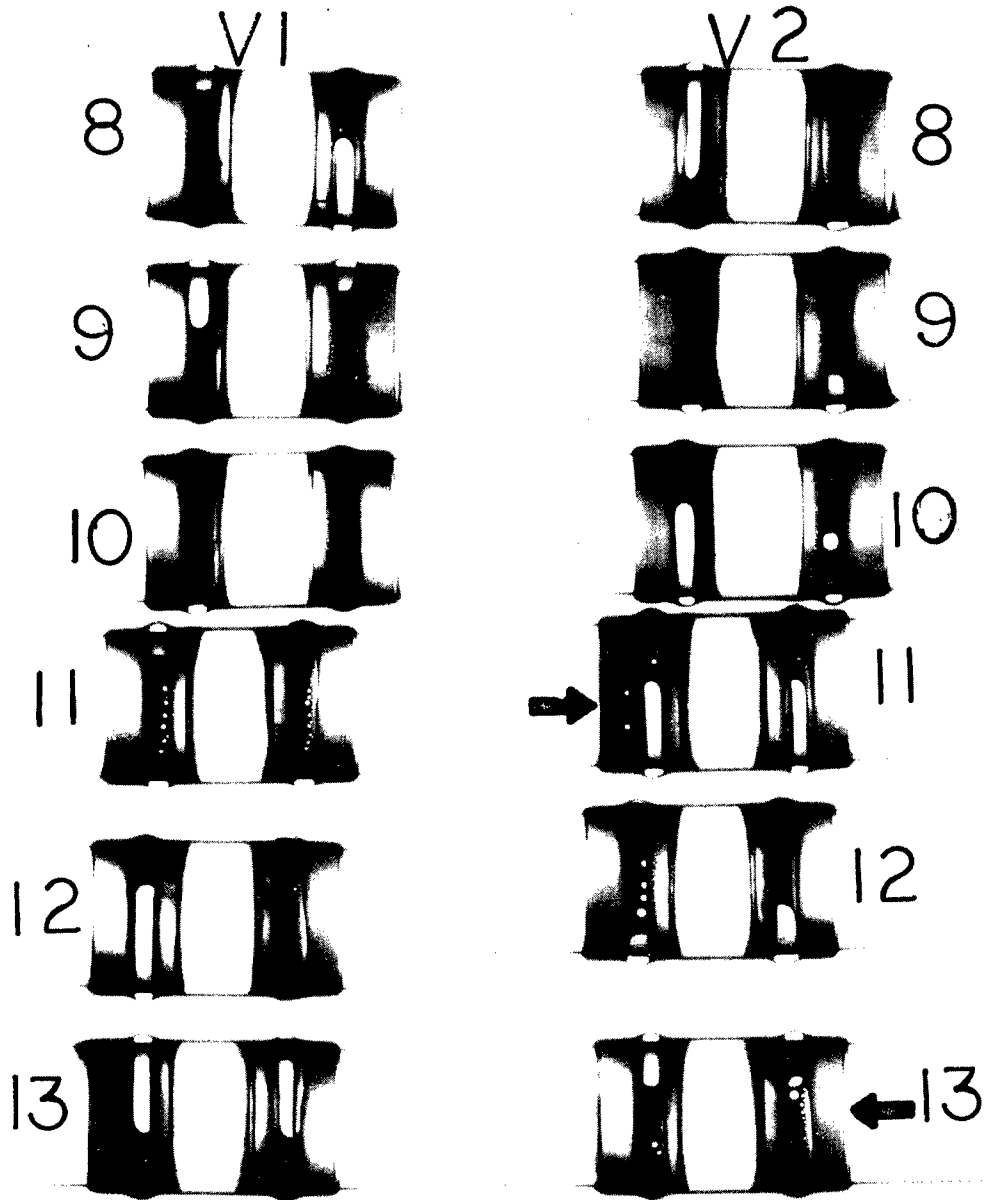

Radiographs taken of six qualification test specimens 8 through 13. The arrow indicates porosity in the braze joint interface area.

FIGURE 17
Test Specimens

Five brazed specimens were pressure proof-tested at 2350 psi for one minute. The pressure was slowly increased until failure occurred. No joint leakage existed. All failures occurred in the tube parent metal (AISI, Type 347, 0.032-in. wall) in the range of 7800 to 8000 psi. Typical failures are shown in Figure 18.

To produce failure in the braze joint sleeve area, the tubes were sectioned approximately 1/2-in. from the sleeve ends. Pressure fittings were welded to the specimen as shown in Figure 19. Failure of the joint occurred at 11,400 psi with no evidence of leakage prior to failure.

The two brazed joints shown in the upper view of Figure 20 were exposed to tensile tests at room temperature. Failures occurred in the tubes at 7160 lb and 7200 lb loads or approximately 97,000 psi ultimate tensile strength. The failure occurred well away from the brazed sleeve, as shown in the lower view of Figure 20.

G. METALLOGRAPHIC EXAMINATION OF BRAZED JOINTS

Several brazed joints were cross-sectioned and examined following burst testing. All brazed specimens contained uniform braze fillets at the tube ends with no evidence of discoloration caused by the brazing cycle heat input. The top view of Figure 15 shows minute porosity in Specimen No. 1 verified by radiographic examination as shown in Figure 16, joint No. 1. This joint was brazed in the free state allowing uniform clearance between the tubes and the sleeve. Gap widths could vary from 0.001-in. to 0.006-in. on the diameter because of tube outside diameter and sleeve inside diameter dimensional tolerances. Distortion of the sleeve and tubes shown in Figure 15 was caused by hydrostatic testing of the joints prior to sectioning.

A cross-sectional view of braze tube Specimen No. 3 is shown in the lower view of Figure 15. This specimen was one of five that was pre-stressed during the brazing cycle to produce zero clearances between the sleeve and tubes in areas indicated by arrows to the left of the joint. The arrow on the upper right of the lower view in Figure 15 indicates the area where no braze fillet existed. Brazing alloy flowed the full length of the joint up to the internal radius at the sleeve end. The braze was not visible during visual external inspection.

All joints that were sectioned had uniform braze fillets at the inner portions of the tube ends. The internal joint surfaces were free of surface discoloration and contamination in areas that had been exposed to the 1900°F to 1950°F temperature during the brazing cycle.

The upper view shown in Figure 21 is a photomicrograph taken of an area where zero clearance existed during the brazing operation shown by the lower left arrow in Figure 15. Although zero clearance existed, the braze alloy was present in the full length of the joint and there was a minimum braze thickness of 0.000085-in.

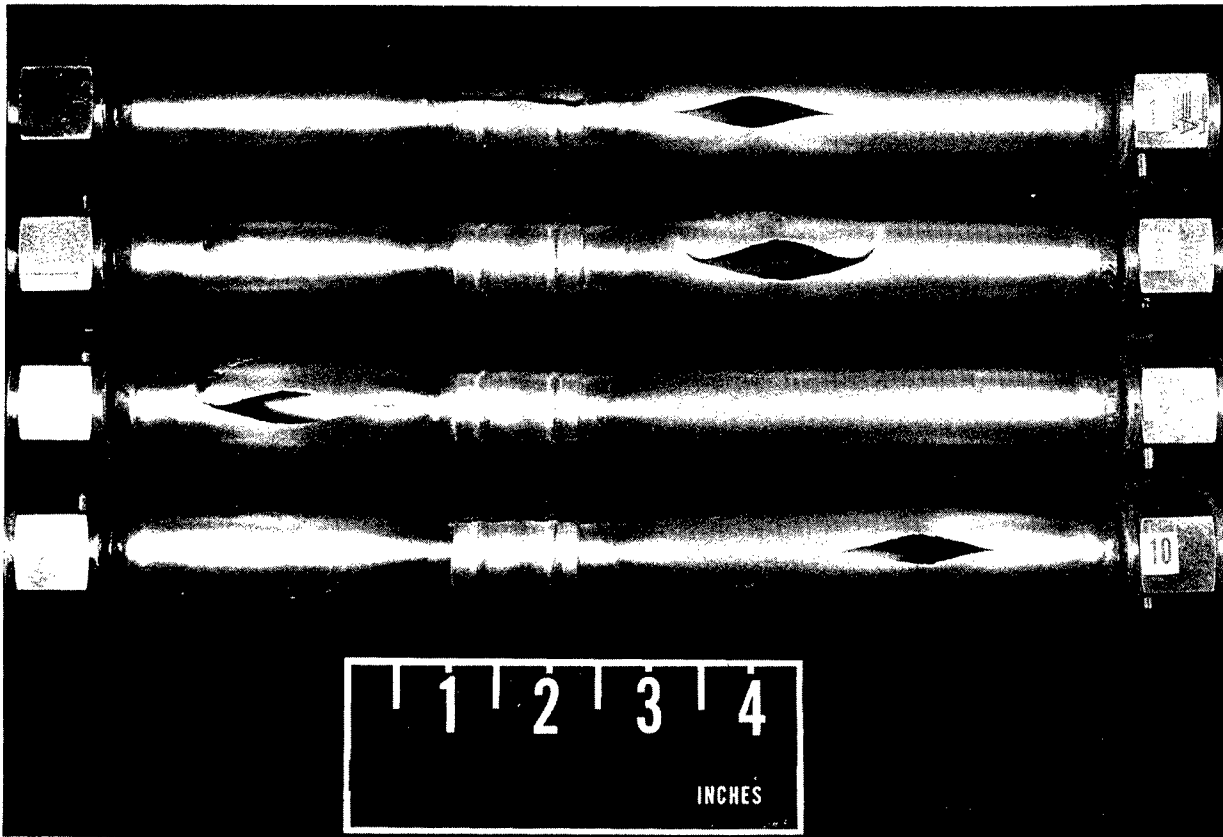

Typical type failures of the tubes which occurred during burst testing in the range of 7800 to 8000 psi.

FIGURE 18

Typical Type Tube Failures

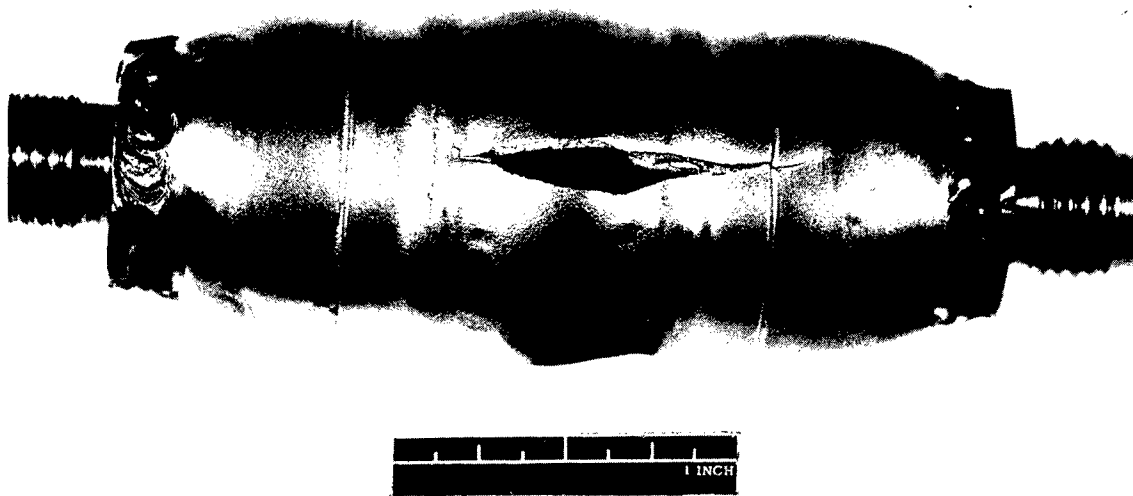

Brazed sleeve burst specimen showing failure in the connector sleeve.

FIGURE 19

Brazed Sleeve Burst Specimen

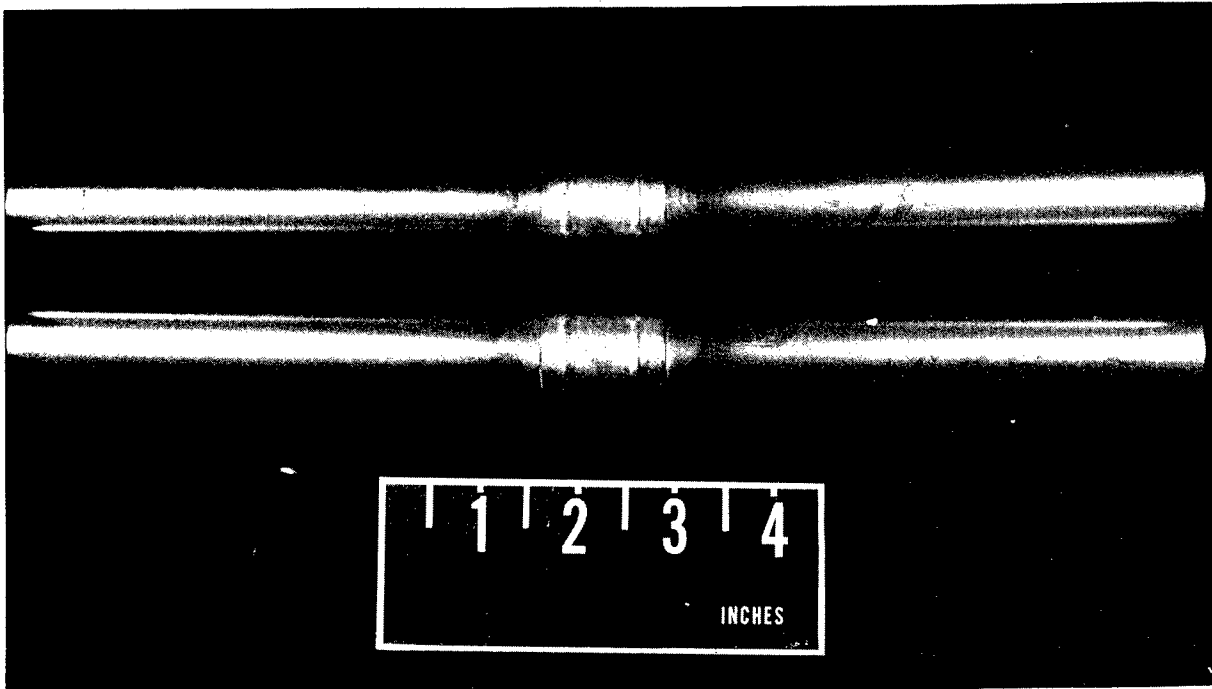

Two typical brazed specimens prepared for tensile testing.

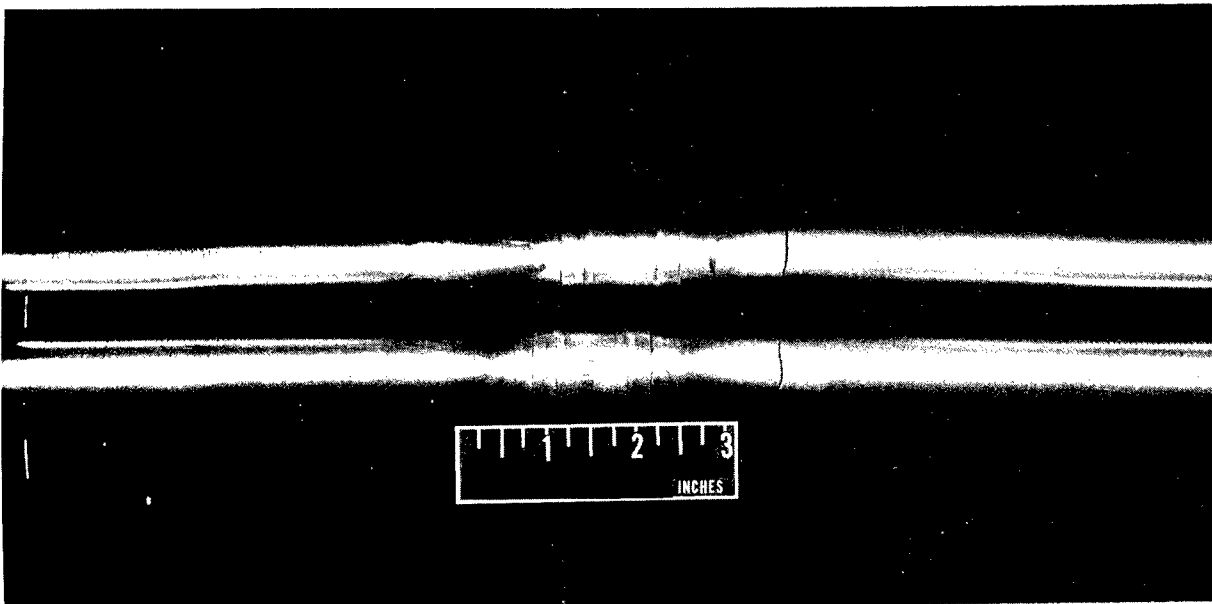

The same two specimens after tensile testing at room temperature. Failures occurred at 7160 and 7200 pounds in the tubes.

FIGURE 20

Connector Brazed Tensile Specimens

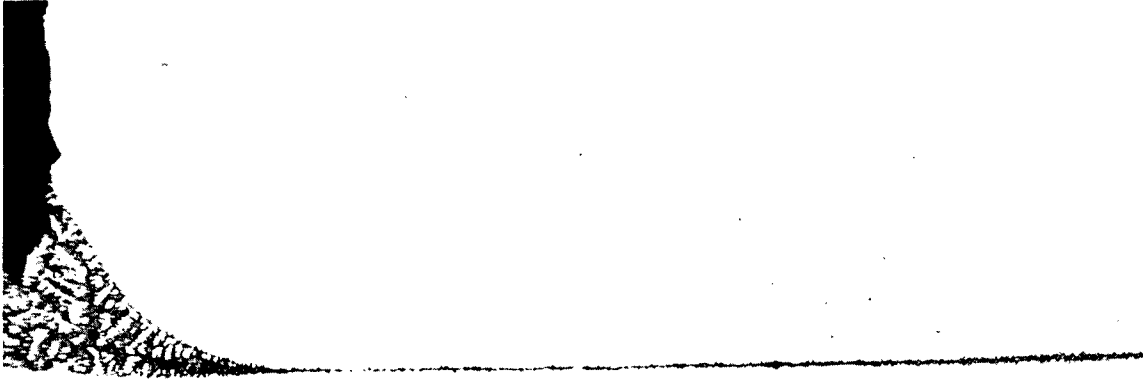

Magnification 100X

An enlarged view of a braze joint taken from the end of the sleeve where zero clearance existed. The braze thickness is 0.000085 in. at the minimum gap.

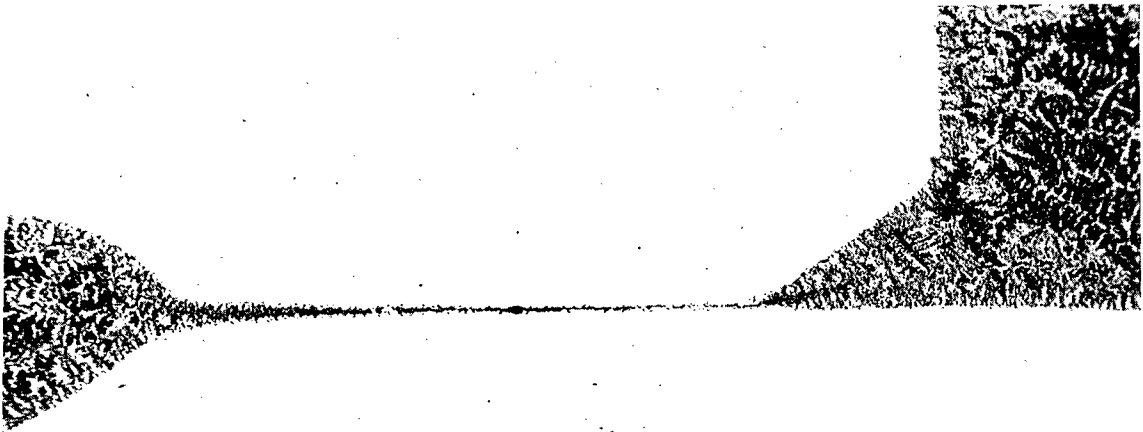

Magnification 100X

A view of the contact area between the sleeve braze alloy retaining cavity and the tube end of a restrained joint during brazing.

FIGURE 21

Two Braze Joint Areas

The lower view of Figure 21 is a photomicrograph taken from an area between the braze alloy retaining cavity and the tube end. The joint was pre-stressed during the brazing cycle to produce zero clearance between the mating members.

Uniform braze alloy flowed in all joints sectioned that were in either the free or restrained state during the brazing cycle.

An end view of one joint that was pre-stressed during the brazing operation is shown in Figure 22. This pre-stressing caused zero clearance in the area indicated by the arrow and maximum gap width at the opposite side of the arrow. Another end view of one joint that was in the free state during the brazing cycle is shown in Figure 23. This joint is representative of normal joint clearance. A small void is present in the area indicated by an arrow. Voids of this magnitude were detected by radiographic examination, as shown in Figures 16 and 17. These spherical voids exhibit a bright surface condition which indicates a complete argon shrouding of the sleeve joint during the braze cycle.

IV. CONCLUSIONS

The induction brazing process for joining separable tube connectors is the best method available as compared with the other tube-joining methods examined. Induction brazed joints require no additional internal cleaning, which is an advantage for complex hardware such as the M-1 thrust chamber. Portability of the induction brazing process is an asset to fabrication of extremely large and complex components. Accomplishing the brazing operation is limited only by the length of the power leads from the radio frequency generator. Braze joints of high quality can be produced in inaccessible areas and in misaligned joints where minimum and maximum gaps exist at joint areas. Three methods for repairing or replacing brazed fittings are feasible. Induction brazed leak-tight joints show parent tube material failure during the burst and tensile tests. Minute voids in the joints can be detected from radiographic inspection; however, voids of the extent found were not deleterious as evidenced by successful pressure testing (i.e., no leakage and fracture in the tube parent material).

V. RECOMMENDATIONS

Further work should be conducted on brazed sleeves, elbows, and Tee joints in various diameters to determine the effects of thermal and pressure cycling and vibration on joint strength and leakage.

Additional work is needed for repair and replacement techniques. This is needed to both refine the techniques and to perform tests for the purpose of evaluating the quality of the repaired units. Other engine applications should be investigated for the potential of improving reliability and reducing weight.

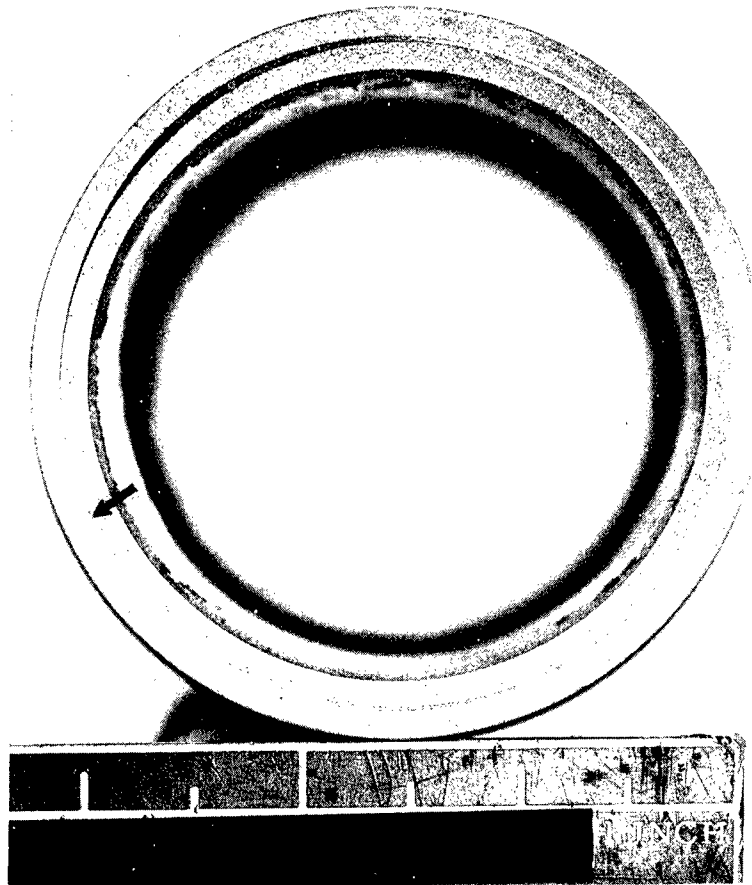

An end view of a restrained joint showing braze alloy flow in areas ranging from zero to 0.006 in. gap width. The area having zero clearance is shown by the arrow.

FIGURE 22

Pre-Stressed Joint (End View)

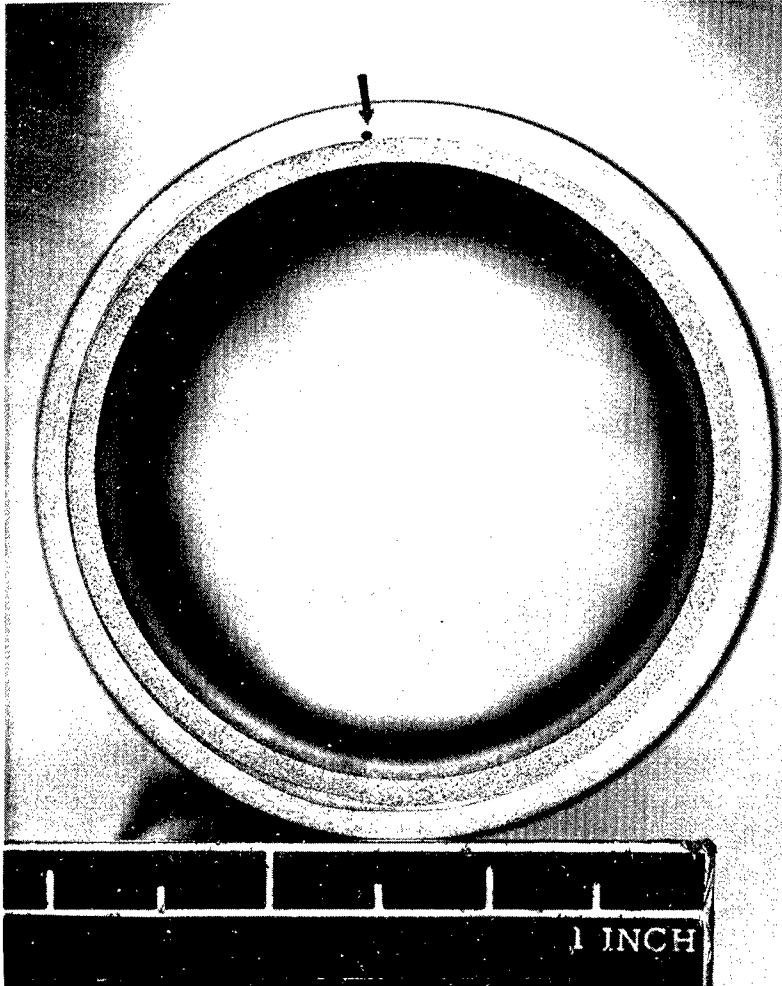

End view of a brazed joint showing full braze flow and a small void in the upper portion of the joint.

FIGURE 23

Brazed Joint (End View)

"The aeronautical and space activities of the United States shall be conducted so as to contribute . . . to the expansion of human knowledge of phenomena in the atmosphere and space. The Administration shall provide for the widest practicable and appropriate dissemination of information concerning its activities and the results thereof."

—NATIONAL AERONAUTICS AND SPACE ACT OF 1958

NASA SCIENTIFIC AND TECHNICAL PUBLICATIONS

TECHNICAL REPORTS: Scientific and technical information considered important, complete, and a lasting contribution to existing knowledge.

TECHNICAL NOTES: Information less broad in scope but nevertheless of importance as a contribution to existing knowledge.

TECHNICAL MEMORANDUMS: Information receiving limited distribution because of preliminary data, security classification, or other reasons.

CONTRACTOR REPORTS: Technical information generated in connection with a NASA contract or grant and released under NASA auspices.

TECHNICAL TRANSLATIONS: Information published in a foreign language considered to merit NASA distribution in English.

TECHNICAL REPRINTS: Information derived from NASA activities and initially published in the form of journal articles.

SPECIAL PUBLICATIONS: Information derived from or of value to NASA activities but not necessarily reporting the results of individual NASA-programmed scientific efforts. Publications include conference proceedings, monographs, data compilations, handbooks, sourcebooks, and special bibliographies.

Details on the availability of these publications may be obtained from:

SCIENTIFIC AND TECHNICAL INFORMATION DIVISION
NATIONAL AERONAUTICS AND SPACE ADMINISTRATION
Washington, D.C. 20546