

## **Staring 256 x 256 LWIR Focal Plane Array Performance of the Raytheon Exoatmospheric Kill Vehicle**

J. Herring, L. Bollengier, D. Madajian, C. Magoun, L. Pham,  
S. Price, W. Ritchie, , E. Schulte, R. Wyles  
Raytheon Infrared Center of Excellence  
75 Coromar Dr.  
Goleta, California

H. Howarth, W. Burk, D. Oleson, K. Pflibsen, S. Wald  
Raytheon Missile Systems Company  
Tucson, Arizona

### **ABSTRACT**

As part of the Exoatmospheric Kill Vehicle (EKV) Exoatmospheric Flight Test (EFT), the Raytheon Infrared Center of Excellence (RIR CoE) has produced many high performance LWIR focal plane arrays (FPAs) for use in interceptor flight tests scheduled 1999. Each of the two LWIR FPAs per EKV consists of a single 256 x 256 S-117 readout multiplexer hybridized to a LWIR or VLWIR detector and mounted to a ceramic / beryllium module assembly. Flexible kapton cables with fine line constantan conductors provide electrical interconnections to the near-FPA Sensor Electronics. To date the RIR COE has delivered a sufficient quantity of Detector Module Assemblies to support the successful Seeker Flight Test conducted on 16 January 1998, and Exoatmospheric Flight Tests scheduled in 1999.

The LWIR detectors are 30 um x 30 um in size and arranged in a 256 x 256 array format. The liquid phase epitaxy (LPE) double layer heterojunction (DLHJ) detectors are designed to provide optimized cutoff wavelengths and performance characteristics for each of the two IR spectral bands that are utilized for target detection and discrimination. Both IR FPAs provide near-theoretical performance characteristics and are cooled using LN<sub>2</sub> to facilitate a rapid, in-flight cooldown to the operating temperature of 70K. The cryo-CMOS multiplexer utilizes a high charge capacity, direct injection (DI) unit cell with on-FPA background subtraction for ultra-high radiometric performance. The 256 x 256 unit cells are multiplexed onto two outputs, each operating at a 2.0 MHz data rate.

These FPAs have excellent responsivity and response uniformity, near-theoretical noise equivalent irradiance (NEI) and outstanding operability. In addition, these FPAs have been produced in sufficient quantities to support the demanding schedule requirements of multiple, near-term launches throughout 1999.

Work Funded by the Space and Missile Defense Command, Huntsville Alabama  
Contract Number: DASG60-90-C-0166

**REPORT DOCUMENTATION PAGE**

Form Approved OMB No.  
0704-0188

Public reporting burden for this collection of information is estimated to average 1 hour per response, including the time for reviewing instructions, searching existing data sources, gathering and maintaining the data needed, and completing and reviewing this collection of information. Send comments regarding this burden estimate or any other aspect of this collection of information, including suggestions for reducing this burden to Department of Defense, Washington Headquarters Services, Directorate for Information Operations and Reports (0704-0188), 1215 Jefferson Davis Highway, Suite 1204, Arlington, VA 22202-4302. Respondents should be aware that notwithstanding any other provision of law, no person shall be subject to any penalty for failing to comply with a collection of information if it does not display a currently valid OMB control number. PLEASE DO NOT RETURN YOUR FORM TO THE ABOVE ADDRESS.

<b>1. REPORT DATE (DD-MM-YYYY)</b> 01-01-1998	<b>2. REPORT TYPE</b> Conference Proceedings	<b>3. DATES COVERED (FROM - TO)</b> xx-xx-1998 to xx-xx-1998
--	---	---

<b>4. TITLE AND SUBTITLE</b> Staring 256 x 256 LWIR Focal Plane Array Performance of the Raytheon Exoatmospheric Kill Vehicle Unclassified	<b>5a. CONTRACT NUMBER</b>
	<b>5b. GRANT NUMBER</b>
	<b>5c. PROGRAM ELEMENT NUMBER</b>

<b>6. AUTHOR(S)</b> Herring, J. ; Bollengier, L. ; Madajian, D. ; Magoun, C. ; Pham, L. ;	<b>5d. PROJECT NUMBER</b>
	<b>5e. TASK NUMBER</b>
	<b>5f. WORK UNIT NUMBER</b>

<b>7. PERFORMING ORGANIZATION NAME AND ADDRESS</b> Raytheon Infrared Center of Excellence 75 Coromar Dr. Goleta, CAxxxxx	<b>8. PERFORMING ORGANIZATION REPORT NUMBER</b>
---	---

<b>9. SPONSORING/MONITORING AGENCY NAME AND ADDRESS</b> Director, CECOM RDEC Night Vision and Electronic Sensors Directorate, Security Team 10221 Burbeck Road Ft. Belvoir, VA22060-5806	<b>10. SPONSOR/MONITOR'S ACRONYM(S)</b>
	<b>11. SPONSOR/MONITOR'S REPORT NUMBER(S)</b>

**12. DISTRIBUTION/AVAILABILITY STATEMENT**  
A PUBLIC RELEASE

**13. SUPPLEMENTARY NOTES**  
See Also ADM201041, 1998 IRIS Proceedings on CD-ROM.

**14. ABSTRACT**  
As part of the Exoatmospheric Kill Vehicle (EKV) Exoatmospheric Flight Test (EFT), the Raytheon Infrared Center of Excellence (RIR CoE) has produced many high performance LWIR focal plane arrays (FPAs) for use in interceptor flight tests scheduled 1999. Each of the two LWIR FPAs per EKV consists of a single 256 x 256 S-117 readout multiplexer hybridized to a LWIR or VLWIR detector and mounted to a ceramic / beryllium module assembly. Flexible kapton cables with fine line constantan conductors provide electrical interconnections to the near-FPA Sensor Electronics. To date the RIR COE has delivered a sufficient quantity of Detector Module Assemblies to support the successful Seeker Flight Test conducted on 16 January 1998, and Exoatmospheric Flight Tests scheduled in 1999. The LWIR detectors are 30 um x 30 um in size and arranged in a 256 x 256 array format. The liquid phase epitaxy (LPE) double layer heterojunction (DLHJ) detectors are designed to provide optimized cutoff wavelengths and performance characteristics for each of the two IR spectral bands that are utilized for target detection and discrimination. Both IR FPAs provide near-theoretical performance characteristics and are cooled using LN2 to facilitate a rapid, in-flight cooldown to the operating temperature of 70K. The cryo-CMOS multiplexer utilizes a high charge capacity, direct injection (DI) unit cell with on-FPA background subtraction for ultra-high radiometric performance. The 256 x 256 unit cells are multiplexed onto two outputs, each operating at a 2.0 MHz data rate. These FPAs have excellent responsivity and response uniformity, near-theoretical noise equivalent irradiance (NEI) and outstanding operability. In addition, these FPAs have been produced in sufficient quantities to support the demanding schedule requirements of multiple, near-term launches throughout 1999.

**15. SUBJECT TERMS**

<b>16. SECURITY CLASSIFICATION OF:</b>	<b>17. LIMITATION OF ABSTRACT</b> Public Release	<b>18. NUMBER OF PAGES</b> 21	<b>19. NAME OF RESPONSIBLE PERSON</b> Fenster, Lynn lfenster@dtic.mil
			<b>19b. TELEPHONE NUMBER</b> International Area Code Area Code Telephone Number 703767-9007 DSN 427-9007

<b>a. REPORT</b> Unclassified	<b>b. ABSTRACT</b> Unclassified	<b>c. THIS PAGE</b> Unclassified
----------------------------------	------------------------------------	-------------------------------------

## 1.0 INTRODUCTION

The Raytheon Infrared Center of Excellence (IR CoE) has designed, fabricated, tested and delivered 256 x 256 long wave infrared (LWIR) HgCdTe focal plane arrays (FPAs) for use on the EKV program. The IR FPA, shown in Figure 1 mounted in a 100 pin leadless chip carrier for cryogenic radiometric testing, is a 256 x 256 staring array with 30  $\mu\text{m}$  pixels. The FPA consists of a HgCdTe LWIR (IR1) or VLWIR (IR2) detector hybridized to a CMOS readout multiplexer. Both detectors use the IR CoE's standard p-on-n double layer heterojunction (DLHJ) liquid phase epitaxy (LPE) detector growth process. The S-117 readout arrays used for IR1 and IR2 FPAs are identical.

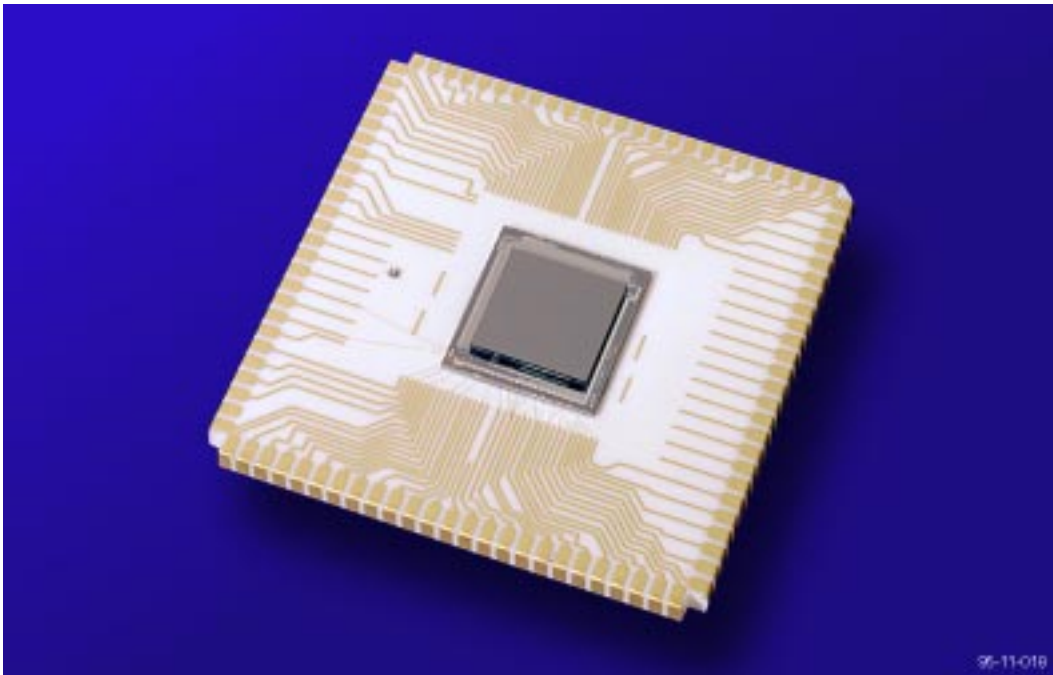

Figure 1 - EKV VLWIR FPA in a 100 pin leadless chip carrier.

## 2.0 LWIR and VLWIR DETECTOR DESIGN AND PERFORMANCE

The detector fabrication process starts with epitaxial growth from our mercury-rich liquid phase epitaxy (LPE) melts. LPE is the only proven technology to provide high quality, production ready HgCdTe detectors. The n-type base-layers were grown on CdZnTe substrates with nominal doping level ranging from  $1\text{E}15$  to  $3.5\text{E}15 \text{ cm}^{-3}$ . The base layer melt required minor tuning prior to actual lot growth to ensure the material composition that meets the program requirements. The base layer composition determines the device cut-off wavelength and performance characteristics. The p+ cap layers were grown with nominal doping of  $2\text{E}17 \text{ cm}^{-3}$ . The finished double layers were then processed using photolithography and wet etch processes to print detector arrays and test structures. As

shown in Figure 2, each pixel was isolated, passivated and electrically accessed via an indium bump. The indium bump provide an electrical contact for electronic readout circuitry once the detector and the readout chips are hybridized to form a sensor. To qualify a given wafer test structure assemblies (TSA) are fabricated, which consist of a detector test structure and a sapphire fanout. The fanout was designed to provide direct access to the active pixel for electrical and optical measurements under cryogenic condition. Using the TSA data, we selected potential candidates for hybridization and test.

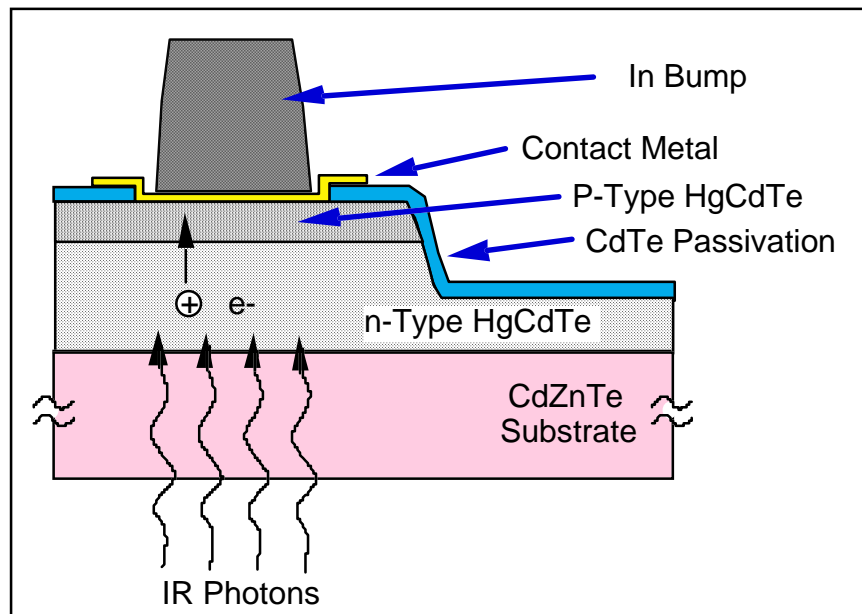

Figure 2 - The cross section view of a finished detector pixel after photolithography processing.

In this section of the paper, we summarize the TSA data on recently processed detector wafers from the PET and EKV programs. The IR1 detector cutoff wavelengths were targeted in the lower range of the LWIR band. In addition to the cut-off wavelength, the required performance for the IR1 detectors were greater than  $10,000 \text{ Ohm-cm}^2$  for  $R_rA$  products and dark currents less than  $36 \text{ pA}$  measured at  $71\text{K}$  and  $20 \text{ mV}$ . The IR2 detector cutoff wavelengths were targeted in the upper-end of the LWIR band. The required performance for these IR2 detectors were greater than  $1,000 \text{ Ohm-cm}^2$  for  $R_rA$  products and less than  $180 \text{ pA}$  for dark currents measured at  $20 \text{ mV}$  and  $71\text{K}$ . These performance requirements were very challenging.

In recent EKV detector lots, we have made significant improvement in our process to increase the device performance and yield. These accomplishments were possible due to focused continuous measurable improvements supported by internal and program funding. Six out of six recently processed IR2 wafers passed the wafer level screening requirements, and four out four recently processed IR1 wafers passed the wafer level requirements. The high yield was unprecedented. The wafer data is summarized in Table I. The detectors from these wafer are stocked and ready for hybridization. Having passed

the wafer level requirement was necessary but insufficient to validate the detector operability requirement. We need additional hybrid data. We expect additional wafer yield loss once hybrid operability data becomes available.

Table I. Recently processed EKV detector wafers exhibit very high performance that meet the screening requirements for both IR1 and IR2 bands. The data are median values of mini-array diodes on the test structures measured at 71K and low background.

Wafer ID	$R_{20A}$ ( $\Omega\text{-cm}^2$ )	$I_{@20mV}$ (pA)	QE % @8.6 $\mu\text{m}$	Band
VX94-50	1.24E5	7.12	78	IR1
VX94-51	3.54E5	28.0	77	IR1
VT36-41	1.02E5	12.1	78	IR1
VT36-42	1.14E5	7.0	77	IR1
<i>IR1</i>	<i>&gt; 1E4</i>	<i>&lt; 36</i>	<i>&gt;60</i>	
<i>Requirements</i>				
VX94-01	3.45E3	147	74	IR2
VX94-02	7.02E3	170	78	IR2
VX94-03	2.73E3	174	78	IR2
VX94-04	4.88E3	138	78	IR2
VX94-05	4.23E3	153	78	IR2
VX94-06	6.81E3	166	72	IR2
<i>IR2</i>	<i>&gt; 1E3</i>	<i>&lt; 180</i>	<i>&gt;60</i>	
<i>Requirements</i>				

In a parallel effort, we built and tested flight hybrids using previously built IR2 PET detectors, which were processed in 1997. The PET Lot A yielded two good IR2 wafers. The median RrA product was  $1.86E4 \Omega\text{-cm}^2$  and the median dark current was 158 pA both measured at 50 mV bias, as illustrated in Figure 3. The other good wafer, VW15-48 had almost identical median values of  $1.86E4 \Omega\text{-cm}^2$  and 153 pA for median RrA and median dark current. Both of these wafers produced very high operable sensors that exceeds 98% against 1.3 to 1 uniformity specification.

We also built and tested flight hybrids from EKV IR1 detector wafer VT36-29. This wafer had median RrA product of  $3.1E5 \text{ Ohm-cm}^2$  and dark current of 5.7 pA measured at 20 mV bias, as shown in Figure 4.

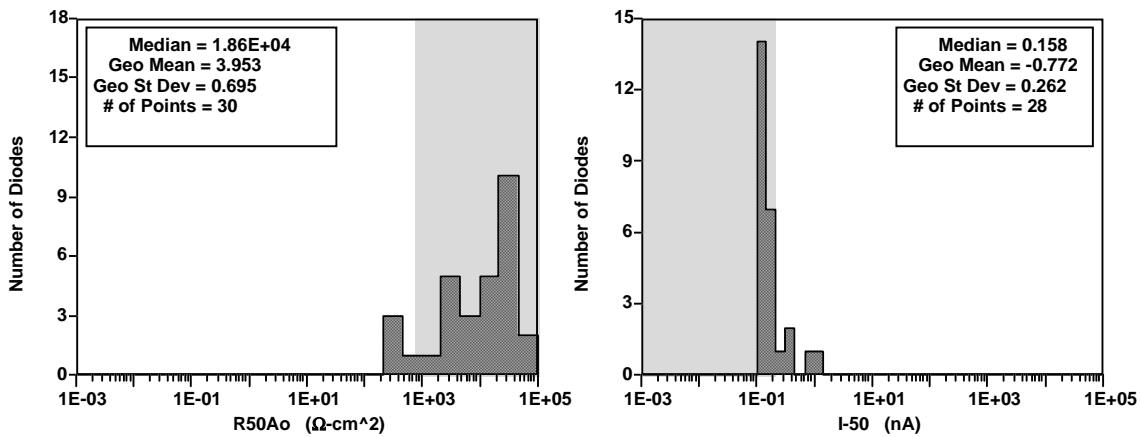

Figure 3 PET Wafer VW15-40 performance measured on test structure samples at 71K . This wafer is an IR2 detector. This wafer produces excellent flight hybrids with greater than 98% operability.

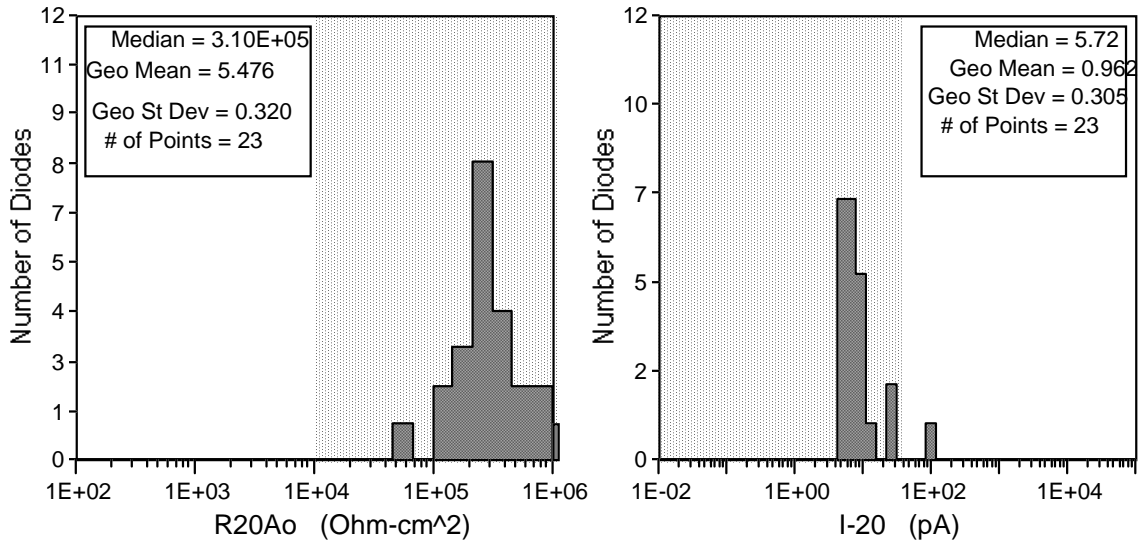

Figure 4. EKV Wafer VT36-29 detector performance measured on test structure samples at 71K. This wafer is an IR1 detector. This wafer produces excellent flight hybrids with greater than 98% operability.

### 3.0 READOUT DESIGN AND PERFORMANCE

The silicon readout multiplexer for the EKV Exoatmospheric Flight Tests is a high charge capacity, fully productized readout array designed and fabricated specifically to meet the requirements of the EKV mission. The readout utilizes a direct injection input circuit to maximize the unit cell area for charge capacity while maintaining excellent injection efficiency and linearity. Charge capacity is enhanced using custom design rules developed at a commercial silicon foundry specifically for EKV and implemented using stacked polysilicon and ROM-implanted capacitors.

The charge capacity of the EKV readout array is the largest implemented to date with 56 million carriers per 30 um unit cell. This has resulted in achieving the required

integration times and consequently outstanding FPA sensitivity and operability with VLWIR HgCdTe detectors. All FPA performance requirements, including the difficult Noise Equivalent Irradiance, operability, linearity and power dissipation have been met using the EKV readout array.

The EKV EFT readout is fully productized and requires only two clocks and four biases to operate and provides data on two differential output data bus lines. This readout has been fabricated with excellent yield on both 4" and 6" wafers and approximately 1,000 readouts are in Raytheon IR CoE inventory. A photograph of the EKV S-117 readout wafer is shown in Figure 5 and typical probe data in Figures 6 - 7.

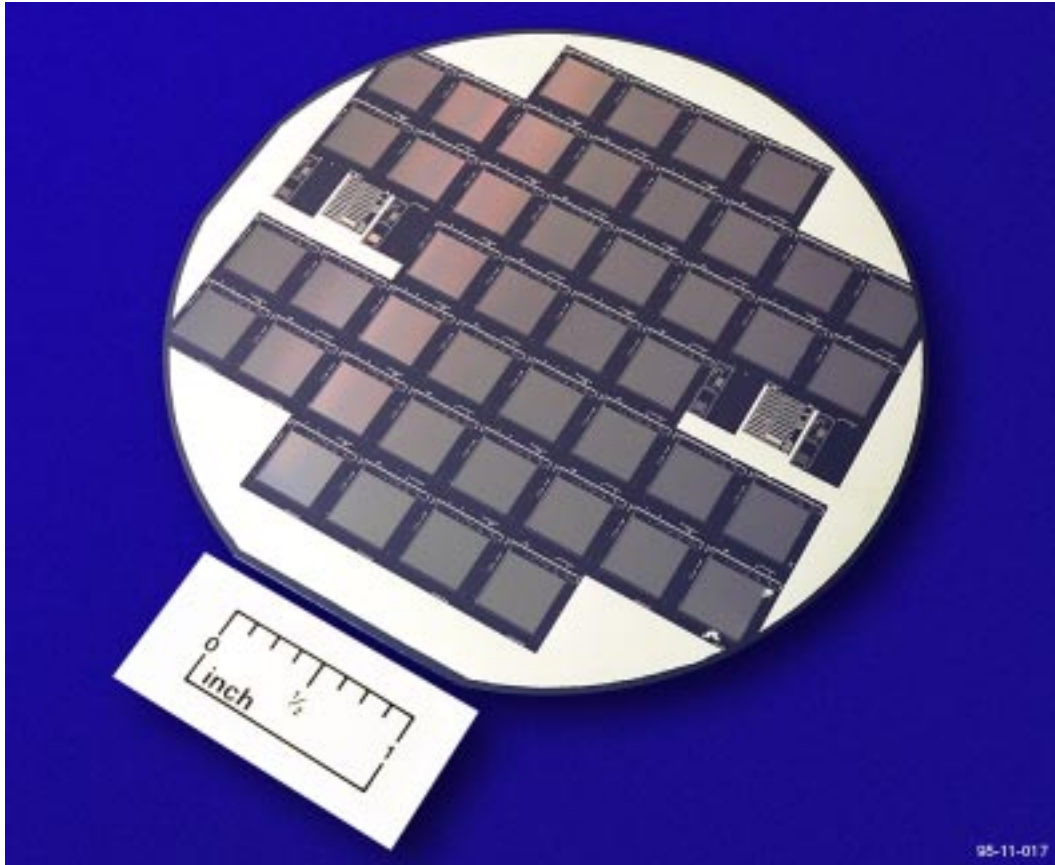

Figure 5 - A 4" EKV SBRC-117 Readout Wafer containing 44 readout die.

**SBRC117 DIE DATA SHEET**

Die : A4	Lot : 3	Wafer : 21
Operator : Scott Freeman	Test Station : DAVID 4	Date : 25-Oct

TEST 1 : Voltage / Current Readback **PASS**

Biases	Nominal Voltage (volts)	Measured Voltage (volts)	Measured Current (mA)	Maximum Current (mA)	Pass/Fail	Power (mWatts)
Vout_even	-10.000	-9.994	1.209	-3.000	PASS	-
Vref_2	-10.000	-9.998	0.000	-	-	-
Vref_1	-10.000	-9.997	0.000	-	-	-
Vout_odd	-10.000	-9.997	1.206	-3.000	PASS	-
Vrstuc	-6.000	-5.679	0.008	-0.200	PASS	-
VDDA	-6.000	-6.004	4.780	-10.000	PASS	28.69889
Vramp_gnd	0.000	-0.001	-0.178	-0.200	PASS	-
VSSA	0.000	-0.001	-9.213	-16.000	PASS	-
Vdet_com	0.000	-1.001	0.000	-0.100	PASS	-
Vs_test	-0.020	0.000	0.000	-	-	-
Vramp	-8.000	-8.004	0.001	0.100	PASS	-
Vcap	0.000	0.001	0.000	0.100	PASS	-
Vgate	0.000	-0.498	0.000	-0.100	PASS	-
VSSD	0.000	0.000	-7.508	-8.000	PASS	-
VDDD	-8.000	-7.988	9.672	-10.000	PASS	77.25703
Vuc_bias	-6.000	-5.680	-	-	-	-

Clocks	Nominal Low Rail (Volts)	Nominal High Rail (Volts)	Measured Current (mA)	Pass/Fail
Phi_Int	-1.000	-1.000	0.000	PASS
Phi_MC	-5.000	-5.000	0.000	PASS

TEST 2 : Power Consumption **PASS**

Total power from VDD readings above : 107 mW  
Maximum power allowed : 110 mW

TEST 3 : Offset Uniformity **PASS**

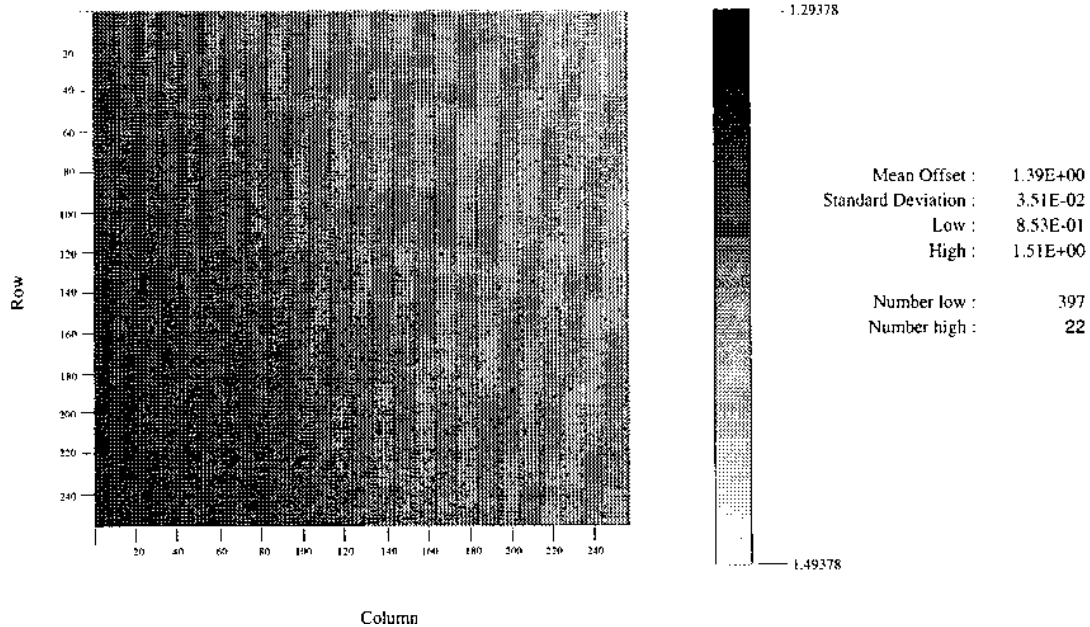

Figure 6 - EKV EBRC-117 Readout Wafer test data indicating good power dissipation and excellent output offset uniformity.



#### 4.0 LWIR (IR1) FPA PERFORMANCE

The Raytheon IR CoE has designed, fabricated, tested and delivered IR1 (LWIR) FPAs in support of the EKV Exoatmospheric Flight Test program. FPA testing is performed after the FPA is integrated into its motherboard, populated with passive components and assembled onto a leadless chip carrier. A photograph of an assembled FPA / Fanout Assembly is shown in Figure 8. The FPA / Fanout Assembly consists of a ceramic motherboard that is patterned with gold traces to provide electrical interfaces from the FPA to the leadless chip carrier (LCC). The ceramic motherboard also supports noise filtering resistors, capacitors and a temperature sensor to monitor the operating temperature of the FPA. The same basic design has been used on many other Space and Strategic programs at the Raytheon IR CoE.

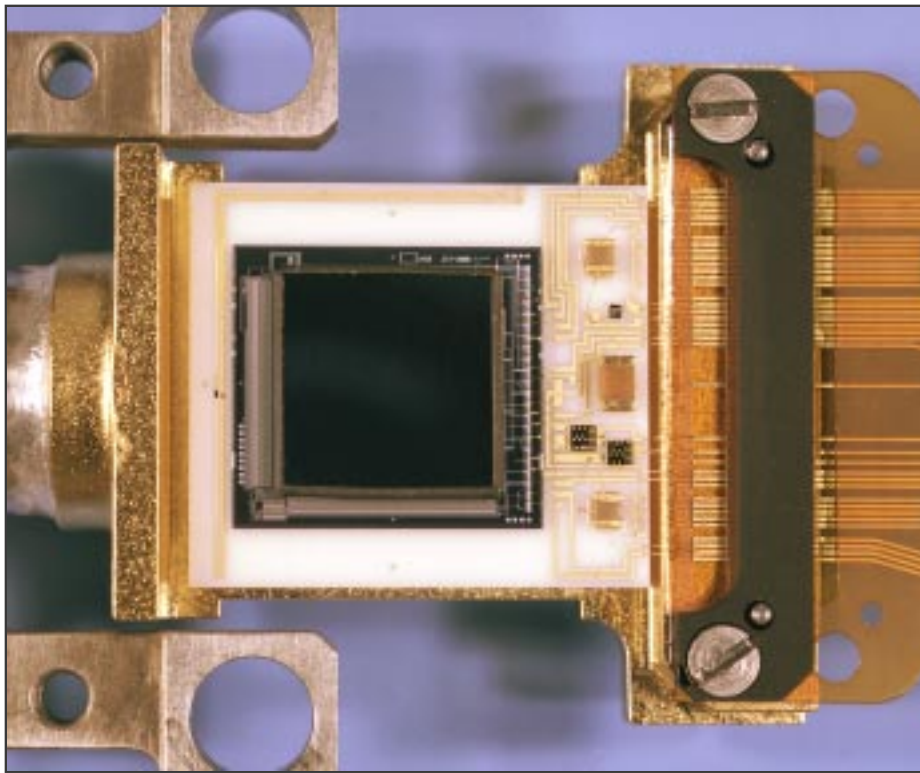

Figure 8 - EKV IR1 LWIR FPA / Fanout Assembly.

All FPA testing is performed at the highest operating temperature in the range of operating temperatures given in the FPA Performance Requirements listed in Table II. The highest operating temperature is used to insure that FPAs are tested at the most aggressive temperature. The FPA Acceptance Tests consist of the following elements:

1. Current / Voltage read back and power dissipation.
2. Starvation and Saturation voltage measurements.
3. LN2 Background and RMS noise measurement.
4. Low background offset and RMS noise measurement.
5. High background offset and reset noise measurements.

From this raw data, responsivity, NEI and the DC output offset are calculated. An operable pixel is defined as one that meets the DC offset uniformity, responsivity and response uniformity, and NEI requirements. The required values for each of these parameters are given in Table II. These radiometric measurements are performed using an extended black body illuminating the FPA through an f2.5 aperture, using cold spectral filters and approximately a 3% neutral density filter. The cold neutral density filter is necessary to achieve the low background flux needed while viewing an approximately room temperature black body source. All measurements utilized an integration time of 8.0 msec.

Table II - EKV IR1 (LWIR) FPA Radiometric Performance Test Requirements

Parameter	Test Requirement	Measured
Filter Bandpass	X um - Y um	X um - Y um
Operating Temperature	60 - 71 K	71K
Pixel Size	30 um X 30 um	30 um X 30 um
Configuration	256 x 256	256 x 256
Noise Equivalent Irradiance	< X Ph / cm <sup>2</sup> -sec	< X Ph / cm <sup>2</sup> -sec
Charge Capacity	> 52 Me-	56 Me-
Leakage Current	< 180 pA	15 pA
Instantaneous Dynamic Range	> 390	2,000
Total Dynamic Range	> 2,000	10,000
Response Uniformity	< 1.22:1	1.22:1
Integration Time	8 msec @ 30 Hz	8 msec @ 30 Hz
Master Clock Frequency	2.0 MHz	2.0 MHz
Power Dissipation	< 140 mW	130 mW

Figure 9 shows the gray scale and histogram of the output offset uniformity for FPA # 71300. This output offset pedestal consumes approximately 0.5V of the 3.3V available instantaneous output voltage swing with a measured noise of 600 uV. Thus the instantaneous dynamic range is greater than 4,000 compared to our specification of 390. The total output voltage swing with background suppression is approximately 5.8V yielding a total dynamic range of approximately 10,000 compared to our specification of 2,000.

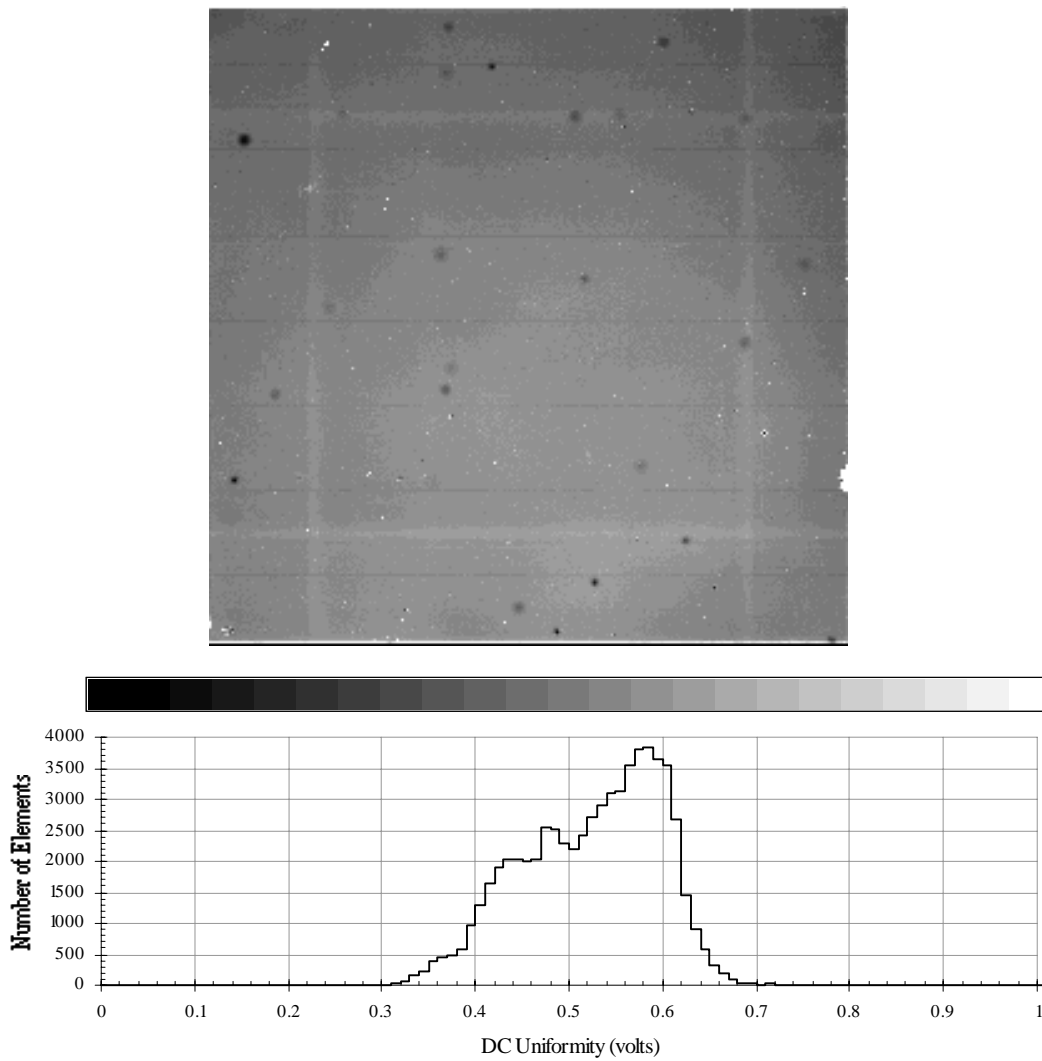

Figure 9 - DC Output Offset Grayscale and Histogram for FPA # 71300 at 71K. This LWIR FPA has an instantaneous dynamic range greater than 2,000 with total dynamic range of 10,000.

The tight 1.22:1 response uniformity was met by most of the FPAs tested with a typical response sigma / mean value of less than 5%. Figure 10 shows the gray scale and histogram of the Responsivity for FPA # 71300. It can be seen from Figure 11 that the responsivity of each FPA was very consistent.

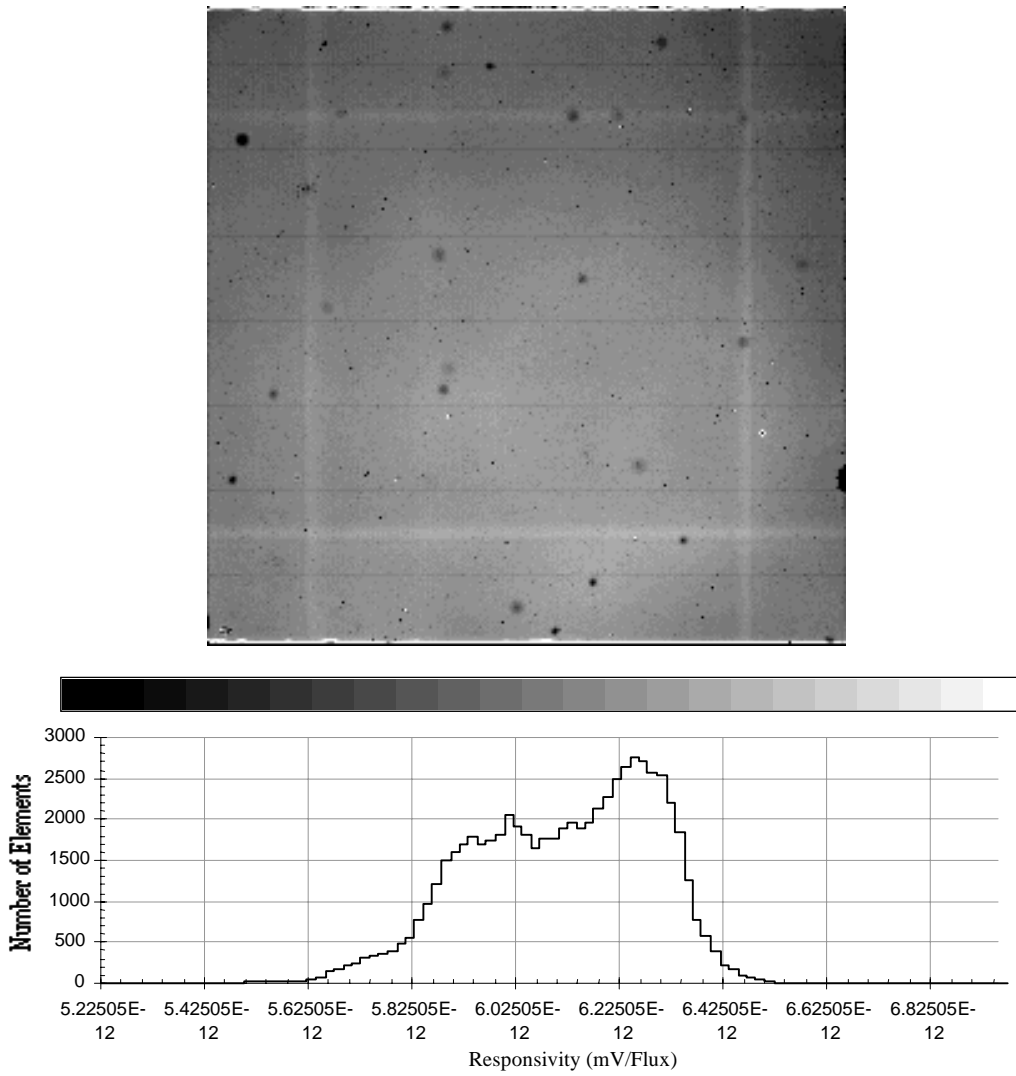

Figure 10 - Responsivity Grayscale and Histogram for FPA # 71300 at 71K. The responsivity sigma/mean is less than 5%.

**IR 1 (LWIR)**  
**Average Responsivity @ 71K**

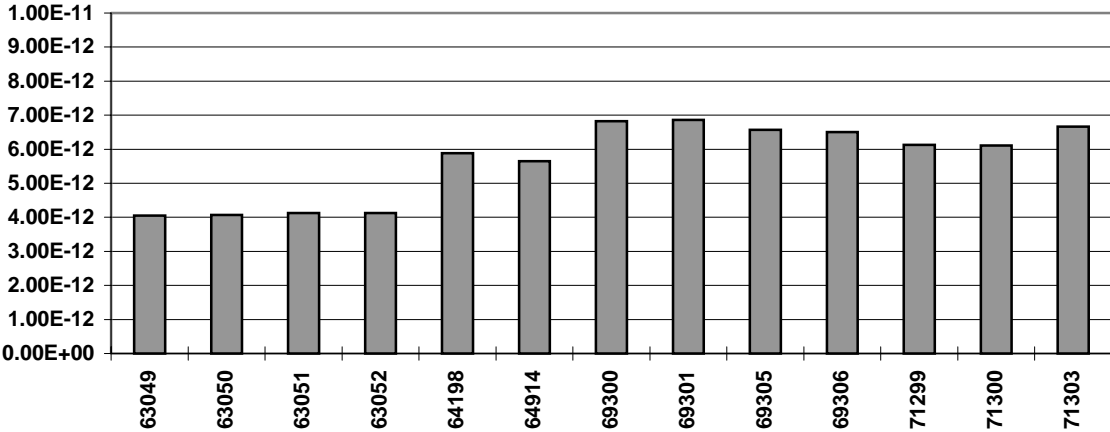

Figure 11 - Responsivity of EKV IR1 (LWIR) FPAs.

The very aggressive Noise Equivalent Irradiance (NEI) specification was met by most of the FPAs tested with a typical operability of greater than 98.5%. Figure 12 shows the gray scale and histogram of the NEI for FPA # 71300. It can be seen from Figure 13 that the NEI of each FPA was very consistent.

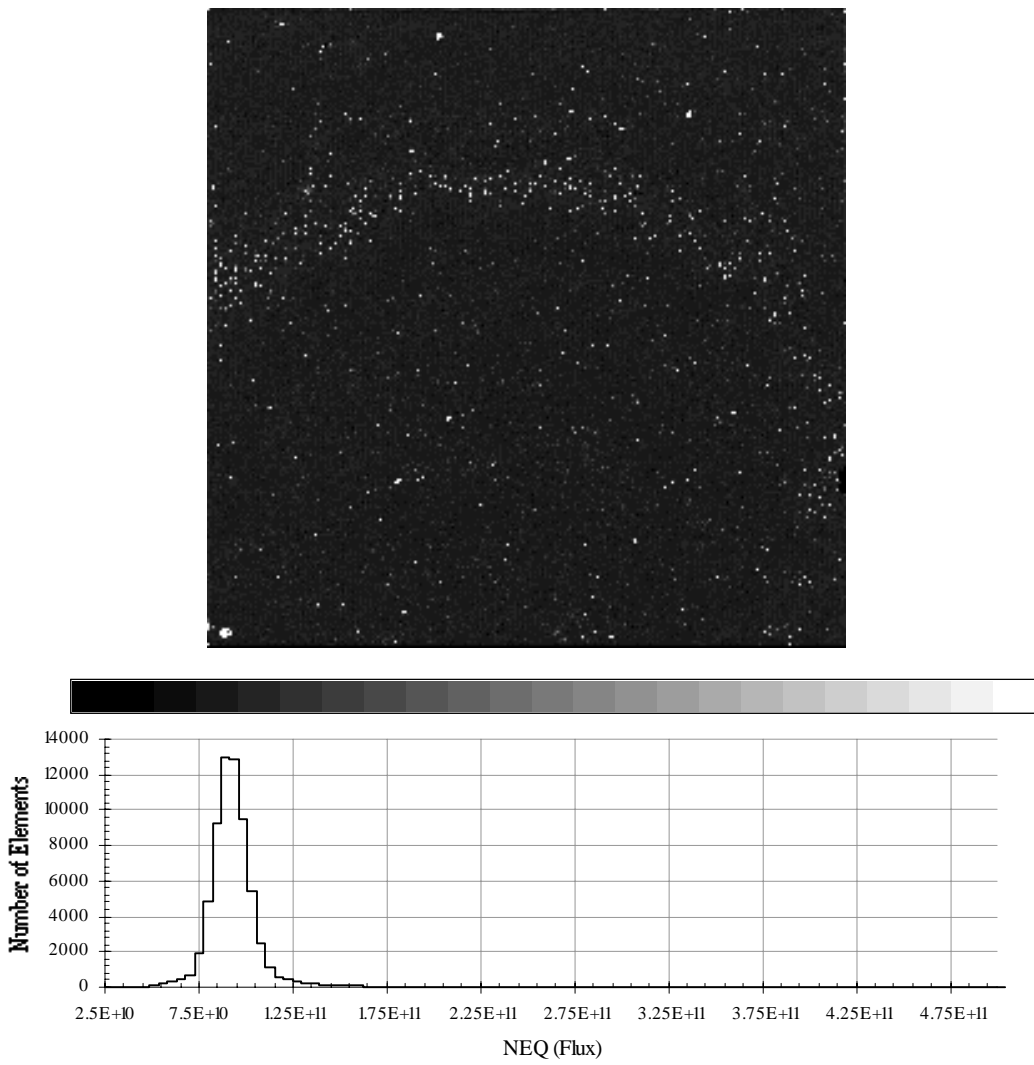

Figure 12 - Noise Equivalent Irradiance Grayscale and Histogram for FPA # 71300 at 71K. The operability of this FPA is approximately 99.5%.

**IR1 (LWIR)  
Average NEI @ 71K**

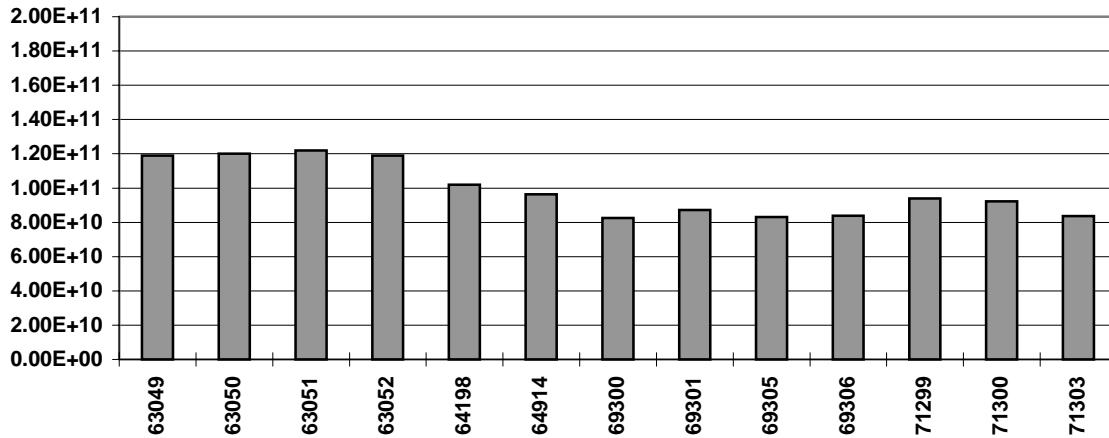

Figure 13 - Noise Equivalent Irradiance of EKV IR1 (LWIR) FPAs.

**5.0 LWIR (IR2) FPA PERFORMANCE**

The Raytheon IR CoE has designed, fabricated, tested and delivered IR2 (VLWIR) FPAs in support of the EKV Exoatmospheric Flight Test program. Similar to the IR1 (LWIR) FPA testing, the IR2 (VLWIR) testing utilizes the same tests as those tests performed on IR1s, and IR2 FPA tests are performed after the FPA is integrated into its motherboard, populated with passive components and assembled onto a leadless chip carrier.

An IR2 (VLWIR) performance matrix is given in Table III. All measurements utilized an integration time of 8.0 msec.

Table III - EKV IR2 (VLWIR) FPA Radiometric Performance Test Requirements

Parameter	Test Requirement	Measured
Filter Bandpass	X um - Y um	X um - Y um
Operating Temperature	60 - 71 K	71K
Pixel Size	30 um X 30 um	30 um X 30 um
Configuration	256 x 256	256 x 256
Noise Equivalent Irradiance	< X Ph / cm <sup>2</sup> -sec	< X Ph / cm <sup>2</sup> -sec
Charge Capacity	> 52 Me-	56 Me-
Leakage Current	< 180 pA	150 pA
Instantaneous Dynamic Range	> 390	1,000
Total Dynamic Range	> 2,000	5,000
Response Uniformity	< 1.33:1	1.22:1
Integration Time	8 msec @ 30 Hz	8 msec @ 30 Hz
Master Clock Frequency	2.0 MHz	2.0 MHz
Power Dissipation	< 140 mW	130 mW

Figure 14 shows the gray scale and histogram of the output offset uniformity for FPA # 71713. This output offset pedestal consumes approximately 0.5V of the 3.3V available instantaneous output voltage swing with a measured noise of 600 uV. Thus the instantaneous dynamic range is greater than 1,000 compared to our specification of 390. The total output voltage swing with background suppression is approximately 5.8V yielding a total dynamic range of approximately 5,000 compared to our specification of 2,000.

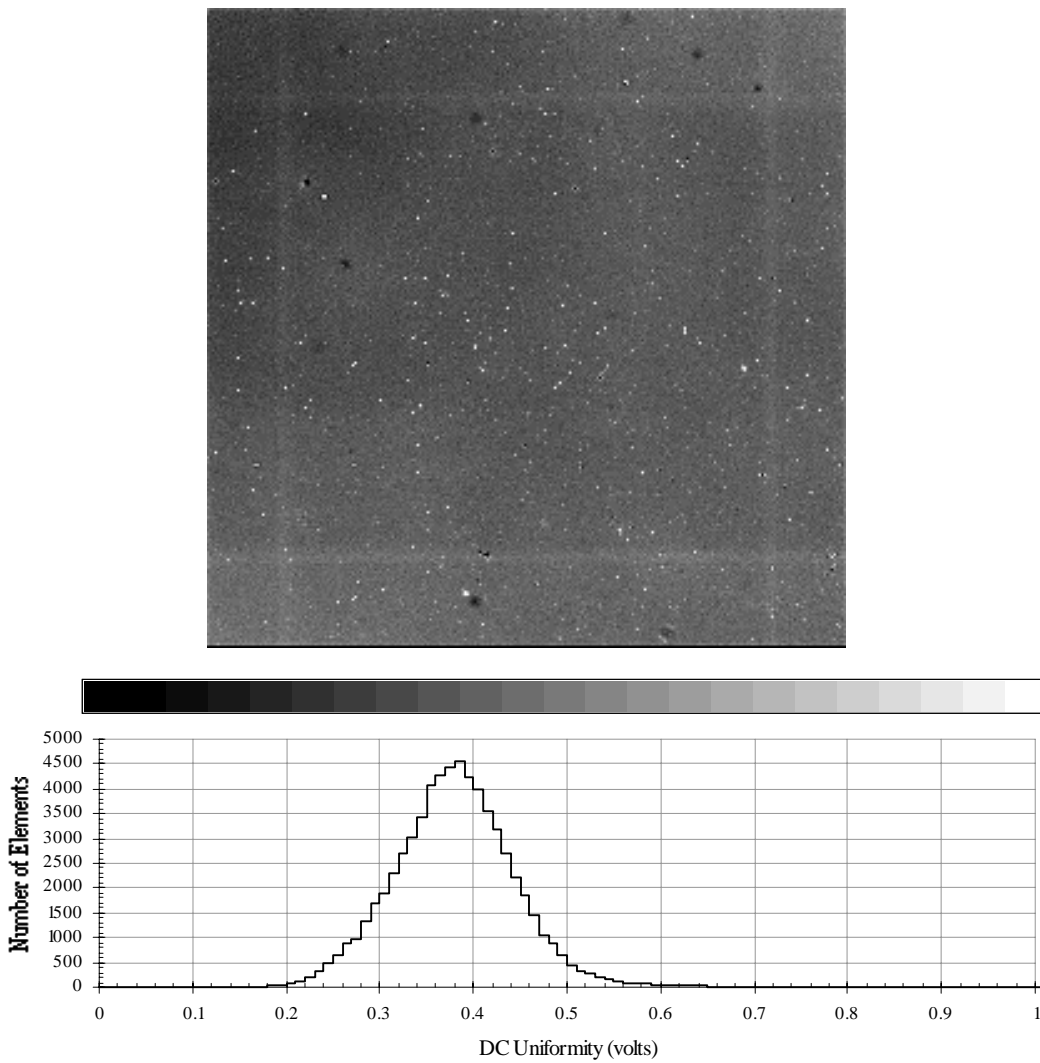

Figure 14 - DC Output Offset Grayscale and Histogram for FPA # 71713 at 71K. This VLWIR FPA has an instantaneous dynamic range greater than 1,000 with total dynamic range of 5,000.

The tight 1.22:1 response uniformity was met by most of the FPAs tested with a typical response sigma / mean value of less than 5%. Figure 15 shows the gray scale and histogram of the Responsivity for FPA # 71713. It can be seen from Figure 16 that the responsivity of each FPA was very consistent.

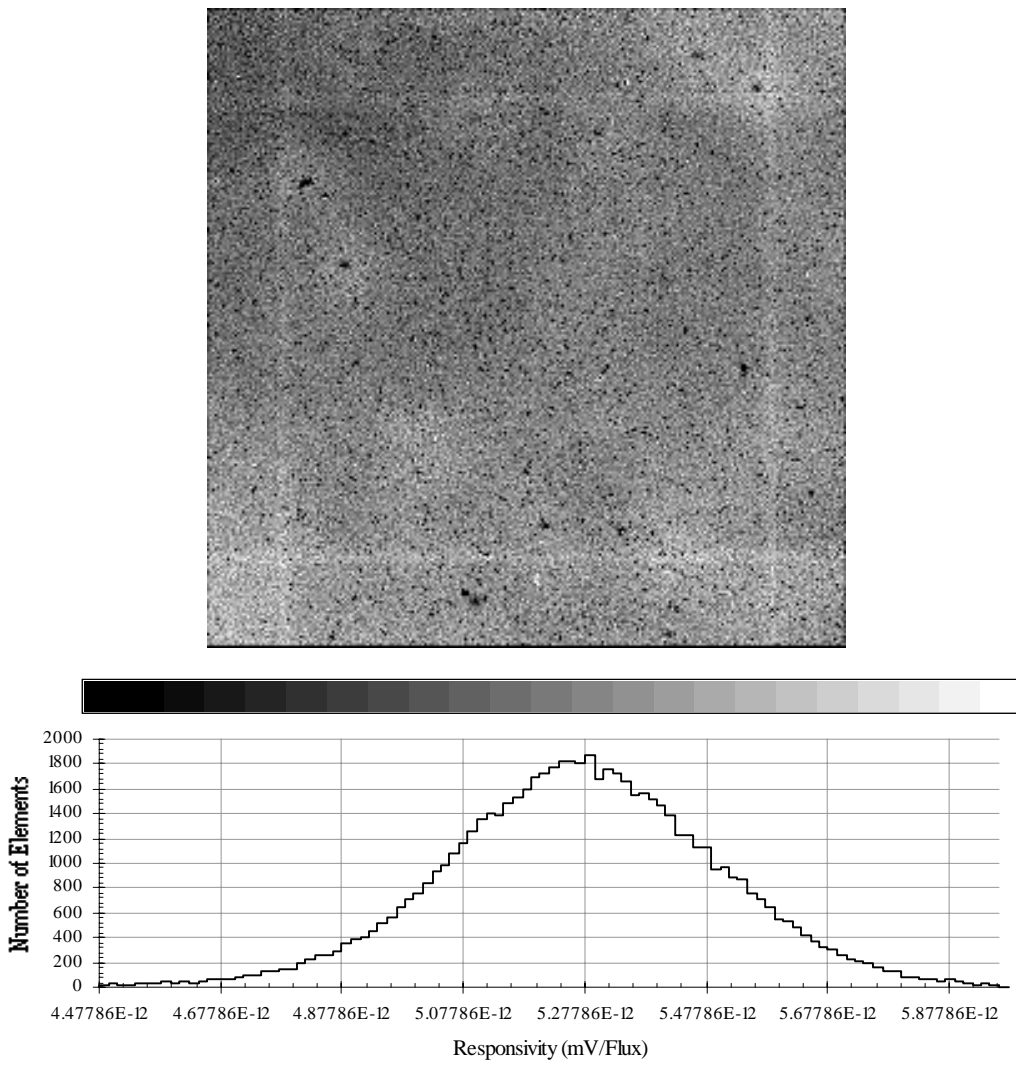

Figure 15 - Responsivity Grayscale and Histogram for FPA # 71713 at 71K. The responsivity sigma/mean is less than 5%.

**IR2 (VLWIR)  
Average Responsivity @ 71K**

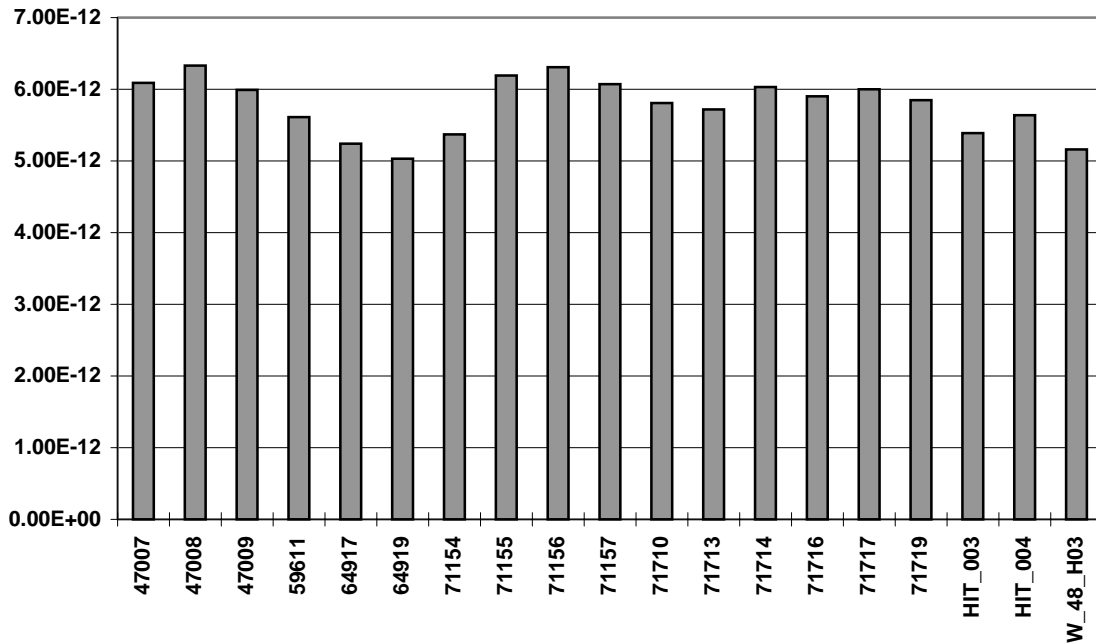

Figure 16 - Responsivity of EKV IR2 (VLWIR) FPAs.

The very aggressive Noise Equivalent Irradiance (NEI) specification was met by most of the FPAs tested with a typical operability of greater than 98.5%. Figure 17 shows the gray scale and histogram of the NEI for FPA # 71713. It can be seen from Figure 18 that the NEI of each FPA was very consistent.

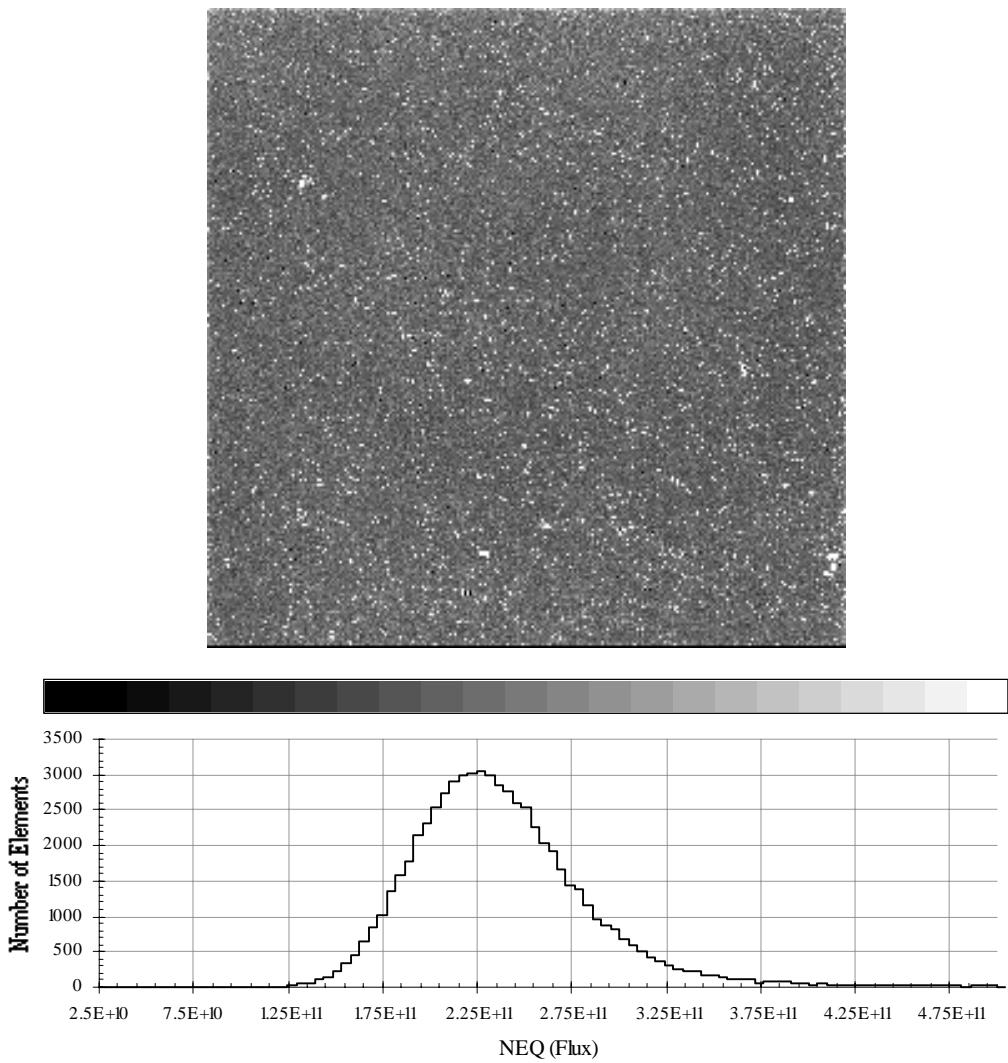

Figure 17 - Noise Equivalent Irradiance Grayscale and Histogram for FPA # 71713 at 71K. The operability of this FPA is approximately 98.5%.

**IR2 (VLWIR)  
Average NEI @ 71K**

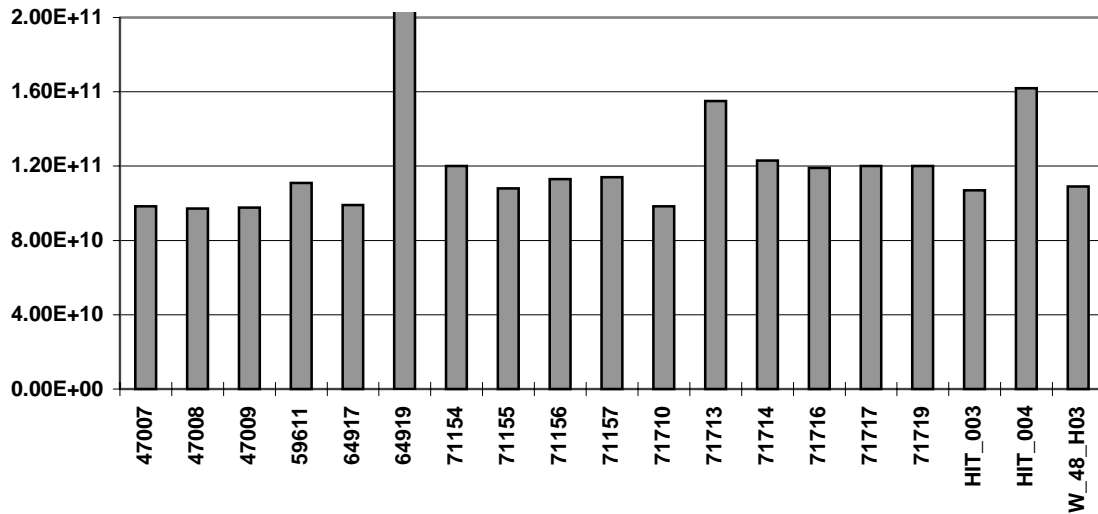

Figure 18 - Noise Equivalent Irradiance of EKV IR2 (VLWIR) FPAs.

## 6.0 SUMMARY AND CONCLUSIONS

As part of the Exoatmospheric Kill Vehicle (EKV) Exoatmospheric Flight Test (EFT), the Raytheon Infrared Center of Excellence (RIR CoE) has developed and produced many high performance LWIR focal plane arrays (FPAs) for use on the EKV program. These FPAs utilize full custom, ultra-high performance readouts and detectors and provide excellent responsivity and response uniformity, near-theoretical noise equivalent irradiance (NEI) and outstanding operability. In addition, these FPAs have been produced in sufficient quantities to support the demanding schedule requirements of the EKV program.